

Printing Instructions

1. Mouse Click Print Icon. 
2. On Print Setup page make sure Page Scaling is set to none.
(See below)

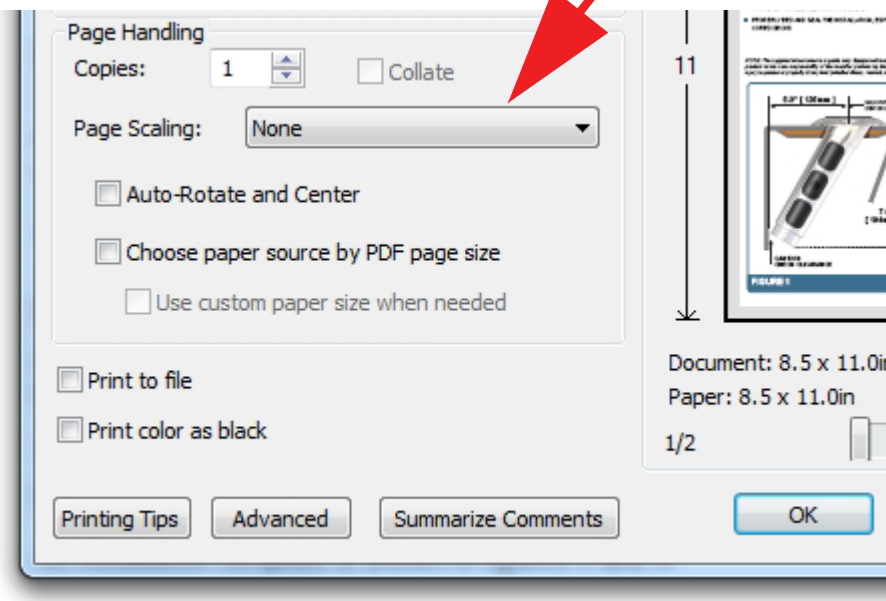

3. After printing the mounting guide use an accurate ruler to verify that the 2 $\frac{5}{8}$ " measurements on the template are correct.



IMPORTANT

PLEASE READ THIS GUIDE COMPLETELY BEFORE INSTALLATION

READ BEFORE INSTALLATION

- CHECK UNDER THE GUNWALE FOR HIDDEN COMPONENTS, SUCH AS ELECTRICAL, HYDRAULIC, FUEL, OR STEERING LINES.
- ACCOUNT FOR ADEQUATE PRODUCT CLEARANCE. (SEE FIGURES IN THIS GUIDE)
- USE A BACKING PLATE AS REQUIRED. SEE BURNEWIIN #BP620
- USE GALVANIC INSULATION GASKETS AS REQUIRED ON ALUMINUM BOATS. SEE BURNEWIIN #G410
- PROPERLY BED AND SEAL THE INSTALLATION, ESPECIALLY ON CORED DECKS.
- TO PROPERLY BED AND SEAL, ENSURE THAT YOU DO NOT GET ANY SEALANT IN THE LOCK MECHANISM.

LOCATING THE PRODUCT

To help determine the optimal and most versatile location for each product, review the “recommended configurations” drawing located on the website. (www.burnewiin.com)

INSTALLING A GM400 OR GM650

Properly tighten all mounting bolts. To ensure that all rod holders can tilt to running position, do not install the center of the mount more than 4.0” from the inside of the gunwale edge (see figure 1). If possible allow 5-3/4” (145mm) clearance below the gunwale (see figure 2) to allow use of Burnewiin knives.

An installation template is shown in figure 3.

NEED MORE HELP?

Contact sales@burnewiin.com

NOTE: The supplied information is a guide only. Equipment installation is a job for a professional technician. The installation of any Burnewiin, Inc. (“Burnewiin”) product is the sole responsibility of the installer performing the work. Burnewiin expressly disclaims any liability or responsibility whatsoever for damages or injury to person or property of any kind (whether direct, indirect, consequential or incidental) resulting or arising from the installation of any Burnewiin product.

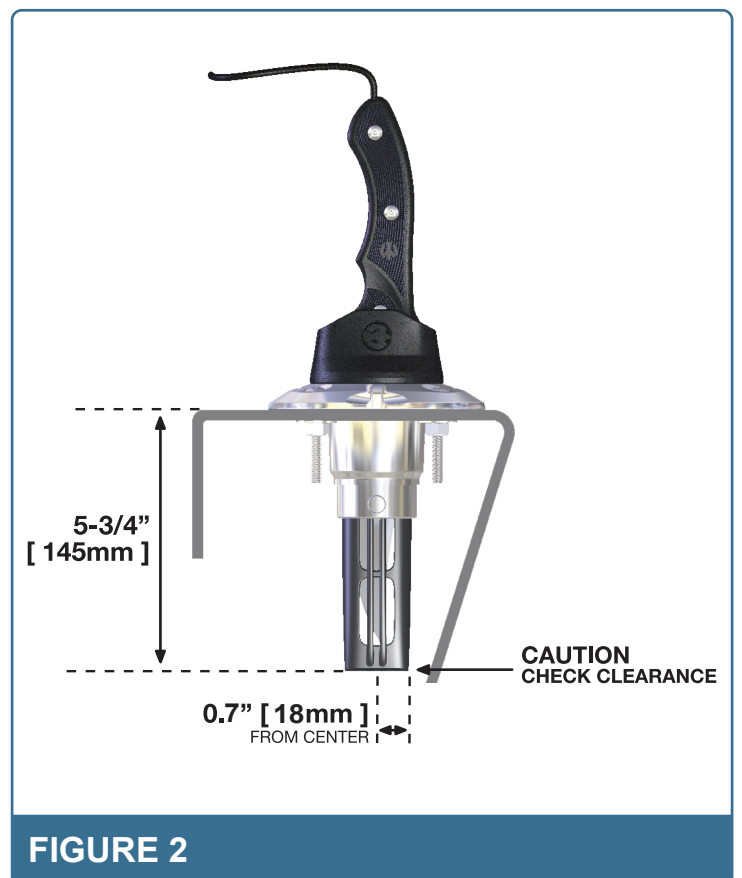
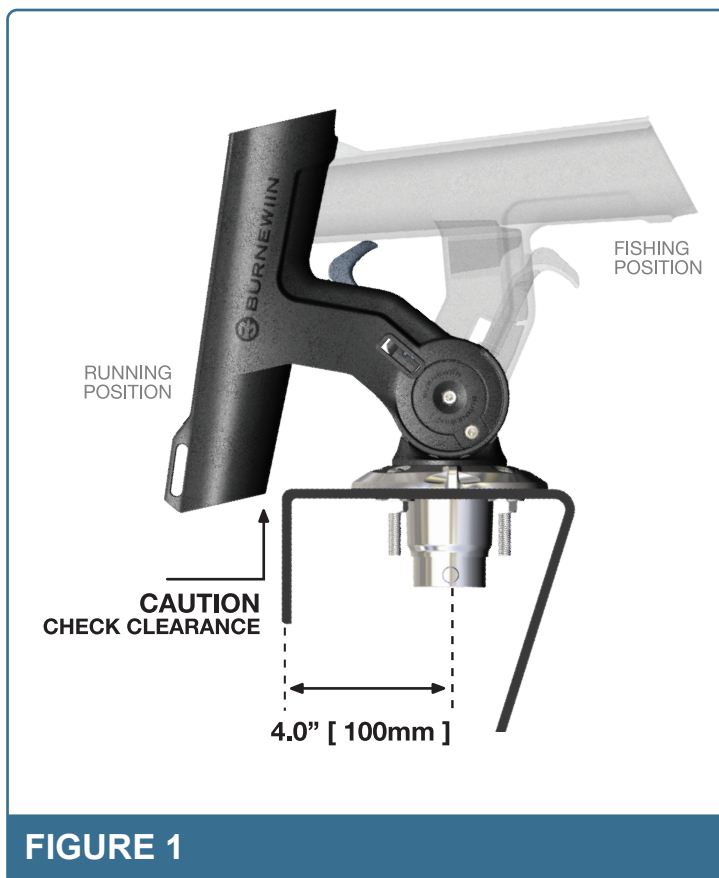

PROFESSIONAL MOUNTING GUIDE

GM400/GM650

IMPORTANT
MANUALLY VERIFY MEASUREMENTS ARE TO SCALE.

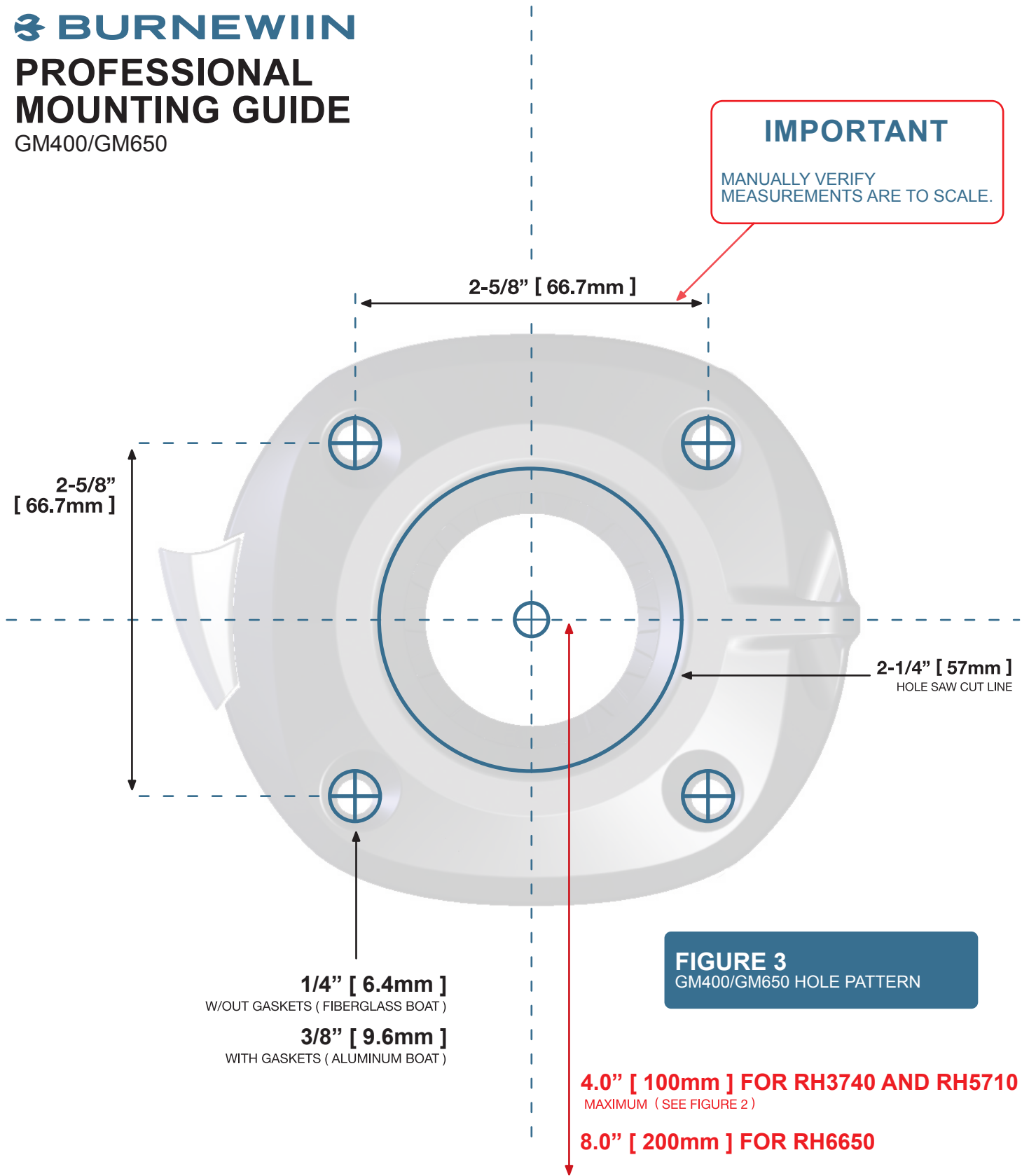

INBOARD EDGE OF GUNWALE OR BOLSTER

Note: This 4" constraint is only necessary for the vertical position of the RH3740 and RH5710 rod holder. The inboard edge of the gunwale or bolster can be as much as 8" for the 45 degree vertical position of the RH6650.