



# 99944200545 Pro-Torque™ Trimmer Attachment

ENGLISH

FOR MODELS: SRM-2100SB, 2400SB, 210SB, 211SB, 225SB, 260SB, 261SB, PAS-2100, 2400, 2601, 210, 211, 225, 225VP, 225VPB, 230, 231, 260, 261, 265, 266, 280

## *Operator's Manual*

### **WARNING**



***Read and understand operator's manual (and safety manual if included) before use. Failure to read the manuals could result in serious injury.***

Specifications, descriptions and illustrative material in this literature are as accurate as known at the time of publication, but are subject to change without notice. Illustrations may include optional equipment and accessories, and may not include all standard equipment.

X7702093807

© 3/2018 ECHO Inc.

---

**TABLE OF CONTENTS**

---

Table of Contents ..... 2

Introduction ..... 3

Servicing Information ..... 3

    Parts/Serial Number ..... 3

    Service ..... 3

    ECHO Consumer Product Support..... 4

    Product Registration ..... 4

    Additional or Replacement Manuals ..... 4

Safety ..... 4

    Manual Safety Symbols and Important Information ..... 4

    International Symbols ..... 5

    Personal Condition and Safety Equipment ..... 6

    Equipment..... 11

Description ..... 12

Contents ..... 13

Assembly..... 13

    Power Head Shaft to Lower Shaft Assembly ..... 13

Operation ..... 14

    To Advance Trimmer Line (Automatic Line Head Models) ..... 14

Maintenance ..... 15

    Skill Levels ..... 15

    Maintenance Intervals..... 15

    Lubrication ..... 16

    Nylon Line Replacement..... 17

Storage..... 19

    Storage Hook Installation..... 19

Specifications ..... 19

Product Registration..... 20

Notes..... 22

## INTRODUCTION

This product was designed and manufactured to provide long life and on-the-job dependability. Read and understand all provided literature. Keep manuals in a safe place for future reference. Literature contains specifications and information for safety, operation, maintenance, storage and assembly specific to this product. Scan QR codes for more information.

For questions regarding terms used in this manual, visit:

<https://www.echo-usa.com/Support-Help/Technical-Documents>

OR

<https://www.shindaiwa-usa.com/Tech-Support/Technical-Documents>



## SERVICING INFORMATION

### Parts/Serial Number

Genuine ECHO Parts and Assemblies for your ECHO products are available only from an Authorized ECHO Dealer. When you do need to buy parts always have the Model Number and Serial Number of the unit with you. For future reference write them in the space provided below.

Model No. \_\_\_\_\_

Serial No. \_\_\_\_\_

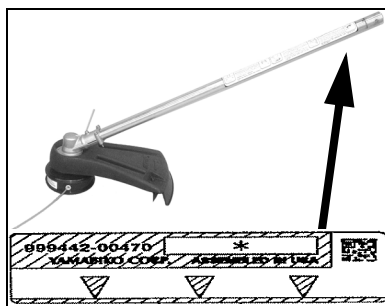

### Service

Service of this product during the warranty period must be performed by an Authorized ECHO Service Dealer. For the name and address of the Authorized ECHO Service Dealer nearest you, ask your retailer or call: 1-800-432-ECHO (3246). Dealer information is also available on our Web Site [www.echo-usa.com](http://www.echo-usa.com). When presenting your unit for Warranty service/repairs, proof of purchase is required.

## ECHO Consumer Product Support

If you require assistance or have questions concerning the application, operation, or maintenance of this product, call the ECHO Consumer Product Support Department at 1-800-673-1558 from 8:00 am to 5:00 pm (Central Standard Time) Monday through Friday. Before calling, please know the model and serial number of your unit.

## Product Registration

Register your ECHO equipment on-line at [www.echo-usa.com](http://www.echo-usa.com) or by filling out the product registration sheet included in this manual. Registering your product confirms warranty coverage and provides a direct link to ECHO if we find it necessary to contact you.

## Additional or Replacement Manuals

Replacement Manuals and Parts Catalogs, are available from your Authorized ECHO Service Dealer, or at [www.echo-usa.com](http://www.echo-usa.com), or by contacting ECHO Inc., 400 Oakwood Road, Lake Zurich, IL 60047 (800-673-1558). Always check [www.echo-usa.com](http://www.echo-usa.com) for updated information.



Safety Videos are available from your Authorized ECHO Service Dealer. A \$5.00 shipping charge is required for each video.

## SAFETY

### Manual Safety Symbols and Important Information

Throughout this manual and on the product itself, you will find safety alerts and helpful, informational messages preceded by symbols or key words. The following is an explanation of those symbols and key words and what they mean to you.

#### **DANGER**

*The safety alert symbol accompanied by the word “DANGER” calls attention to an act or condition which WILL lead to serious personal injury or death if not avoided.*

#### **WARNING**

*The safety alert symbol accompanied by the word “WARNING” calls attention to an act or condition which CAN lead to serious personal injury or death if not avoided.*

**! CAUTION**

*The safety alert symbol accompanied by the word “CAUTION” calls attention to an act or condition which may lead to minor or moderate personal injury if not avoided.*

**NOTICE**

*The enclosed message provides information necessary for the protection of the unit.*

Note: This enclosed message provides tips for use, care and maintenance of the unit.









**CIRCLE AND SLASH SYMBOL**

This symbol means the specific action shown is prohibited. Ignoring these prohibitions can result in serious or fatal injury.

**International Symbols**

Symbol	Description	Symbol	Description
	Warning, See Operator's Manual		Safety / Alert
	Wear Eye, Ear and Head Protection		Finger Severing
	Wear Hand and Foot Protection		Rotating Cutting Attachment
	Wear Face Shield		Wear Slip Resistant Footwear
	Keep Feet Away From Blade		Do not operate closer than 15 m (50 ft.) from electrical hazards. Keep bystanders at least 15 m (50 ft.) away

Symbol	Description	Symbol	Description
	DO NOT USE BLADES - Line Head Only		Thrown Objects
	Plan retreat path from falling objects.		Hot Surface
		<p><b>AVOID KICKOUT</b> Keep Bystanders At Least 15 m (50 ft.) Away</p> <p>Beware Thrown Objects Wear Eye Protection</p>	
		<p>Keep Bystanders and Helpers Away 15 m (50 ft.)</p>	

**Personal Condition and Safety Equipment**

**! WARNING**

**Cancer and Reproductive Harm**  
[www.P65Warnings.ca.gov](http://www.P65Warnings.ca.gov)

**! WARNING**



*The muffler or catalytic muffler and surrounding cover may become extremely hot. Always keep clear of exhaust and muffler area, otherwise serious personal injury may occur.*

**! WARNING**

*Users of this product risk injury to themselves and others if the unit is used improperly and/or safety precautions are not followed. Proper clothing and safety gear must be worn when operating unit.*

## Physical Condition

Your judgment and physical dexterity may not be good:

- If you are tired or sick
- If you are taking medication
- If you have taken alcohol or drugs

Operate unit only if you are physically and mentally well.

## Eye Protection

### **WARNING**

- ◆ **Eye protection that meets ANSI Z87.1 or CE requirements must be worn whenever you operate the unit.**
- ◆ **For additional safety, a full-face shield may be worn over safety glasses or goggles to provide protection from sharp branches or flying debris.**

## Hand Protection

Wear sturdy, no-slip, rubber work gloves to improve your grip on the handles. Gloves also provide protection against cuts and scratches, cold environments, and reduce the transmission of machine vibration to your hands.

## Hearing/Ear Protection

ECHO recommends wearing hearing protection whenever unit is used.

## Breathing Protection

Operators who are sensitive to dust or other common airborne allergens may need to wear a dust mask to prevent inhaling these materials while operating unit. Dust masks can provide protection against dust, plant debris, and other plant matter such as pollen. Make sure the mask does not impair your vision, and replace the mask as needed to prevent air restrictions.

## Proper Clothing

Wear snug-fitting, durable clothing:

- Pants should have long legs, shirts should have long sleeves.
- DO NOT WEAR SHORTS.

- DO NOT WEAR TIES, SCARVES, JEWELRY, or clothing with loose or hanging items that could become entangled in moving parts or surrounding growth.
- Keep clothing buttoned or zipped, and keep shirt tails tucked in.

Wear sturdy work shoes with nonskid rubber soles:

- DO NOT WEAR OPEN TOED SHOES.
- DO NOT OPERATE UNIT BAREFOOTED.

Keep long hair away from engine and air intake. Retain hair with cap or net.

Heavy protective clothing can increase operator fatigue, which may lead to heat stroke. Schedule heavy work for early morning or late afternoon hours when temperatures are cooler.

## WARNING

***The components of this machine generate an electromagnetic field during operation, which may interfere with some pacemakers. To reduce the risk of serious or fatal injury, persons with pacemakers should consult with their physician and the pacemaker manufacturer before operating this machine. In the absence of such information, ECHO does not recommend the use of this machine by anyone who has a pacemaker.***

### Extended Operation / Extreme Conditions

## CAUTION

***Prolonged exposure to cold and/or vibration may result in injury. Read and follow all safety and operation instructions to minimize risk of injury. Failure to follow instructions may result in painful wrist/hand/arm injuries.***

It is believed that a condition called Raynaud's Phenomenon, which affects the fingers of certain individuals, may be brought about by exposure to vibration and cold. Exposure to vibration and cold may cause tingling and burning sensations, followed by loss of color and numbness in the fingers. The following precautions are strongly recommended, because the minimum exposure, which might trigger the ailment, is unknown.



- Keep your body warm, especially the head, neck, feet, ankles, hands, and wrists.
- Maintain good blood circulation by performing vigorous arm exercises during frequent work breaks, and also by not smoking.
- Limit the hours of operation. Try to fill each day with jobs where operating the unit or other hand-held power equipment is not required.
- If you experience discomfort, redness, and swelling of the fingers followed by whitening and loss of feeling, consult your physician before further exposing yourself to cold and vibration.

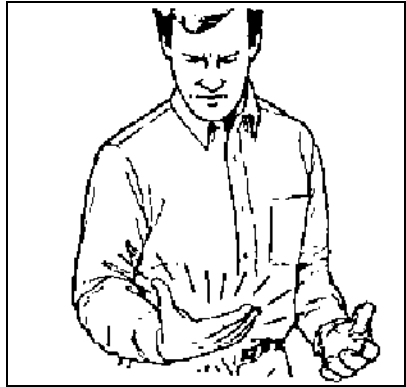

### **Repetitive Stress Injuries (RSI)**

It is believed that overusing the muscles and tendons of the fingers, hands, arms, and shoulders may cause soreness, swelling, numbness, weakness, and extreme pain in those areas. Certain repetitive hand activities may put you at a high risk for developing a Repetitive Stress Injury (RSI). An extreme RSI condition is Carpal Tunnel Syndrome (CTS), which could occur when your wrist swells and squeezes a vital nerve that runs through the area. Some believe that prolonged exposure to vibration may contribute to CTS. CTS can cause severe pain for months or even years.

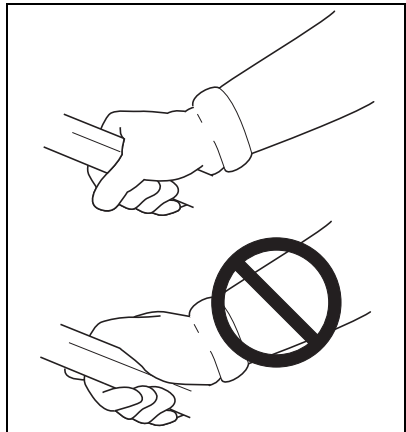

To reduce the risk of RSI/CTS, do the following:

- Avoid using your wrist in a bent, extended, or twisted position. Instead try to maintain a straight wrist position. Also, when grasping, use your whole hand, not just the thumb and index finger.
- Take periodic breaks to minimize repetition and rest your hands.
- Reduce the speed and force with which you do the repetitive movement.
- Do exercises to strengthen the hand and arm muscles.

- Immediately stop using all power equipment and consult a doctor if you feel tingling, numbness, or pain in the fingers, hands, wrists, or arms. The sooner RSI/CTS is diagnosed, the more likely permanent nerve and muscle damage can be prevented.

## DANGER

***All over head electrical conductors and communications wires can have electricity flow with high voltages. This unit is not insulated against electrical current. Never touch wires directly or indirectly, otherwise serious injury or death may result.***

## DANGER

***Do not operate this product indoors or in inadequately ventilated areas. Engine exhaust contains poisonous emissions and can cause serious injury or death.***

### **Read the Manuals**

- Provide all users of this equipment with the Operator's Manual and Safety Manual for instructions on Safe Operation.

### **Clear the Work Area**

- Spectators and fellow workers must be warned, and children and animals prevented from coming nearer than 15 m (50 ft.) while the unit is in use.

### **Keep a Firm Grip**

- Always hold throttle handle and support handle with thumbs and fingers tightly encircling the handles.

### **Keep a Solid Stance**

- Maintain footing and balance at all times. Do not stand on slippery, uneven or unstable surfaces. Do not work in odd positions or on ladders. Do not over reach.



### **Avoid Hot Surfaces**

- During operation, the drive shaft housing and attachment bearing housing may become very hot, too hot to touch. Avoid contact during and immediately after operation.



## Equipment

### **WARNING**

*Use this attachment with ECHO approved models only. Serious injury may result from the use of this attachment combined with a non approved ECHO product.*

- ◆ Check unit for loose/missing nuts, bolts, and screws. Tighten and/or replace as needed.
- ◆ Inspect shield for damage and that shield is securely in place. Replace if shield is damaged or missing.
- ◆ Check that the cutting attachment is firmly attached and in safe operating condition.

Note: ECHO, INC. will not be responsible for the failure of cutting devices, attachments or accessories which have not been tested and approved by ECHO.

### **WARNING**

*Moving parts can amputate fingers or cause severe injuries. Keep hands, clothing and loose objects away from all openings.*

- ◆ *ALWAYS stop engine, disconnect spark plug, and make sure all moving parts have come to a complete stop before removing obstructions, clearing debris, or servicing unit.*
- ◆ *DO NOT start or operate unit unless all guards and protective covers are properly assembled to unit.*
- ◆ *NEVER reach into any opening while the engine is running. Moving parts may not be visible through openings.*

## DESCRIPTION

Locate the safety decal(s) on your unit. Make sure the decal(s) is legible and that you understand and follow the instructions on it. If a decal cannot be read, a new one can be ordered from your ECHO dealer.

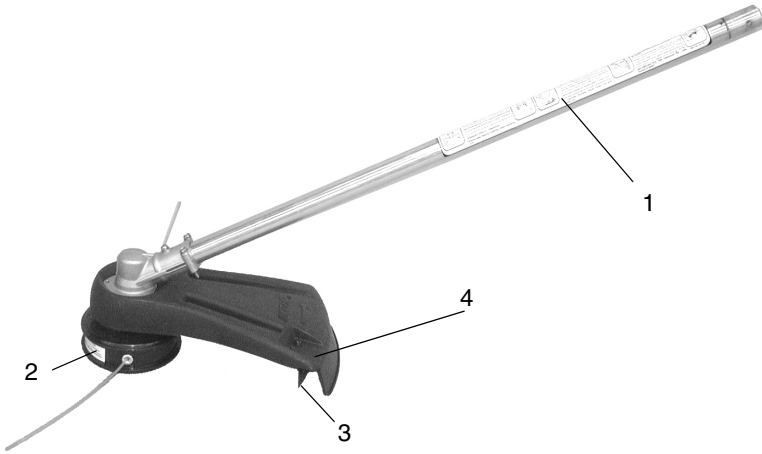

## Shaft Label

	<p><b>ESP PELIGRO</b></p> <p>Este unidad puede ser peligrosa si conduce incorrectamente. Mantenga siempre la cabeza de la línea en el terreno adecuado. Para reducir el riesgo de lesiones o de daños, asegure el ajuste de la longitud de la línea y asegure el ajuste de la velocidad de la línea. Consulte el manual de usuario para obtener más información.</p> <p>www.echo-usa.com o en ECHO Inc., 400 Diamond Road, Lake Zurich, IL 60047 (800-675-1586)</p>	<p><b>EN DANGER</b></p> <p>This unit can be dangerous if operated incorrectly. To reduce injury risk to operator, fingers and bystanders, make sure you understand the correct line length. Always make sure the line is set to the correct length. Refer to the Operator's Manual for more information.</p> <p>www.echo-usa.com or by contacting ECHO Inc., 400 Diamond Road, Lake Zurich, IL 60047 (800-675-1586)</p>	<p><b>⚠ DANGER</b></p> <p>This unit can be dangerous and cause serious injury if operated incorrectly. To reduce injury risk to operator, fingers and bystanders, make sure you understand the correct line length. Always make sure the line is set to the correct length. Refer to the Operator's Manual for more information.</p> <p>Manutenção e 50 feet (15 meters) DANGER ZONE (danger surrounding the operator). Only the operator, dressed in proper protective clothing, should be within the DANGER ZONE. Always wear hearing protection, gloves and sturdy work boots when operating unit.</p>	<p><b>⚠ DANGER</b></p> <p>Rebuilding attachment does not stop immediately after triggering. Always keep hands and feet clear of rotating attachment unless engine STOPPED and cutting attachment is not moving.</p> <p>Do not remove shields, except the unit is approved by ECHO. Approved attachment information and replacement Operator and Safety Manual are available from your ECHO dealer or at <a href="http://www.echo-usa.com">www.echo-usa.com</a> or by contacting ECHO Inc., 400 Diamond Road, Lake Zurich, IL 60047 (800-675-1586).</p> <p><b>⚠ DANGER</b></p> <p>ONLY STRAIGHT SHAFTS UNITS</p> <p>ONLY use ECHO approved blades on Small trimmer heads with equipped with proper blade shield, handle, harness and mounting hardware.</p> <p>Be aware of KICKOUT (kick thrust) when using blades. Special indications are necessary for back operators. Refer to the Operator and Safety Manual.</p> <p>INSPECT BLADES BEFORE USE. DO NOT USE DAMAGED, CRACKED, BENT, DULL OR IMPROPERLY SHARPENED BLADES.</p> <p>800-675-1586</p>
	<p><b>⚠ DANGER</b></p> <p>Rebuilding attachment does not stop immediately after triggering. Always keep hands and feet clear of rotating attachment unless engine STOPPED and cutting attachment is not moving.</p> <p>Do not remove shields, except the unit is approved by ECHO. Approved attachment information and replacement Operator and Safety Manual are available from your ECHO dealer or at <a href="http://www.echo-usa.com">www.echo-usa.com</a> or by contacting ECHO Inc., 400 Diamond Road, Lake Zurich, IL 60047 (800-675-1586).</p> <p><b>⚠ DANGER</b></p> <p>ONLY STRAIGHT SHAFTS UNITS</p> <p>ONLY use ECHO approved blades on Small trimmer heads with equipped with proper blade shield, handle, harness and mounting hardware.</p> <p>Be aware of KICKOUT (kick thrust) when using blades. Special indications are necessary for back operators. Refer to the Operator and Safety Manual.</p> <p>INSPECT BLADES BEFORE USE. DO NOT USE DAMAGED, CRACKED, BENT, DULL OR IMPROPERLY SHARPENED BLADES.</p> <p>800-675-1586</p>			

- DRIVE SHAFT ASSEMBLY** - Contains a specially designed liner and the flexible drive shaft.
- NYLON CUTTING ATTACHMENT** - Contains replaceable nylon trimming line that advances when the trimmer head is tapped against the ground while the head is turning at normal operating speed.
- CUT-OFF KNIFE** - Automatically trims line to the correct length after head is tapped on the ground. If trimmer is operated without a cut-off knife the line will become too long, the engine will overheat, and engine damage may occur.
- DEBRIS SHIELD with CUT-OFF KNIFE** - Required when unit is equipped with nylon line head. Do not operate unit without shield.

## CONTENTS

The ECHO product you purchased has been factory pre-assembled for your convenience. Due to packaging restrictions, some assembly may be necessary.

After opening the carton, check for damage. Immediately notify your retailer or ECHO Dealer of damaged or missing parts. Use the contents list to check for missing parts.

- \_\_\_ 1 - PAS Trimmer Attachment
- \_\_\_ 1 - Operator's Manual
- \_\_\_ 1 - Warranty Sheet
- \_\_\_ 1 - Storage Hook Assembly

## ASSEMBLY

### Power Head Shaft to Lower Shaft Assembly

#### **WARNING**

***Do not perform maintenance or assembly procedures with engine running.***

Parts Required: PAS or SRM-SB Power Head Shaft and Coupling

1. Set Power Head/Shaft Assembly on a level surface.
2. Pull locator pin (A) out, and turn counter-clockwise  $\frac{1}{4}$  turn to lock-out position.
3. Remove vinyl cap from attachment drive shaft.
4. Remove cardboard spacer, if necessary.



Note: Your coupler may appear different than coupler shown.

5. Carefully fit attachment drive shaft assembly into coupler (B) to decal assembly line (C), making sure that the inner lower drive shaft engages the square upper drive shaft socket.

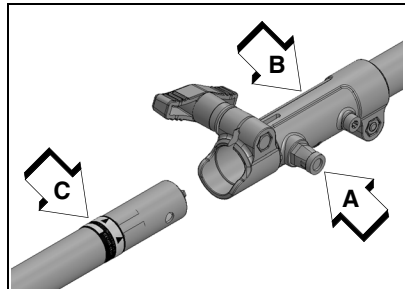

Note: Earlier model power heads may have shorter couplings.

Note: Lower bearing housing and head assembly must be in line with the engine.

6. Rotate locator pin (A) ¼ turn clockwise to engage lower shaft hole. Insure locator pin is fully engaged by twisting lower drive shaft. Locator pin should snap flush in coupler. Full engagement will prevent further shaft rotation.
7. Secure lower shaft assembly to coupler by tightening clamping knob (D).

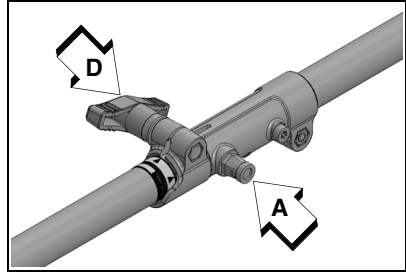

## OPERATION

### **⚠ WARNING**

***Moving parts can amputate fingers or cause severe injuries. Keep hands, clothing and loose objects away from all openings. Always stop engine, disconnect spark plug, and make sure all moving parts have come to a complete stop before removing obstructions, clearing debris, or servicing unit.***

Note: Refer to your PAS power source Operator's Manuals for correct engine fueling, starting and stopping instructions.

### **To Advance Trimmer Line (Automatic Line Head Models)**

See Maintenance Section for nylon line replacement.

To advance trimmer line, tap trimmer head against the ground while the head is turning at normal operating speed.

---

## MAINTENANCE

---

### WARNING

*Moving parts can amputate fingers or cause severe injuries. Keep hands, clothing and loose objects away from all openings. Always stop engine, disconnect spark plug, and make sure all moving parts have come to a complete stop before removing obstructions, clearing debris, or servicing unit. Allow unit to cool before performing service. Wear gloves to protect hands from sharp edges and hot surfaces.*

### WARNING

*Operating a poorly maintained unit can result in serious injuries to operator or bystanders. Always follow all maintenance instructions as written, otherwise serious personal injury may result.*

Your unit is designed to provide many hours of trouble free service. Regular scheduled maintenance will help your unit achieve that goal. If you are unsure or are not equipped with the necessary tools, we recommend that you take your unit to a Servicing Dealer for maintenance. To help you decide whether you want to DO-IT-YOURSELF or have the Dealer do it, each maintenance task has been graded. If the task is not listed, see your Dealer for repairs.

### Skill Levels

**Level 1** = Easy to do. Common tools may be required.

**Level 2** = Moderate difficulty. Some specialized tools may be required.

**Level 3** = See your dealer.

Click [HERE](#) or go to <http://www.echo-usa.com/products/maintenance-kit>  
or

[HERE https://www.shindaiwa-usa.com/you-can.aspx](https://www.shindaiwa-usa.com/you-can.aspx)

For information about maintenance kits.

**Maintenance Intervals**

Component/ System	Maintenance Procedure	Skill Level	Interval
Drive Shaft	Grease	1	Every 25 hours of use <sup>1</sup>
Gear Housing			Every 50 hours of use <sup>1</sup>
Screws/Nuts/Bolts	Inspect/Tighten/ Replace		Before Each Use

**IMPORTANT** - Time intervals shown are maximum. Actual use and your experience will determine the frequency of required maintenance.

1. Apply lithium based grease.

**Lubrication**

**Level 1.**

Parts Required: Lithium Based Grease.

**Gear Housing**

1. Clean all loose debris from gear case.
2. Remove plug (A) and check level of grease.
3. Add grease if necessary. DO NOT over-fill.
4. Install plug (A).

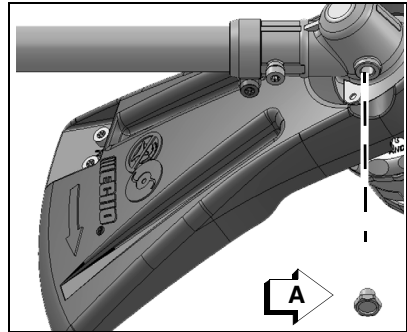



### Drive Shaft (Lower)

1. Loosen screw (B) and remove locating screw (C). Pull gear case and shield from drive shaft housing.
2. Pull flexible cable from the drive shaft housing, wipe clean and re-coat with 15 ml (0.5 oz.) of grease.
3. Slide the flexible cable back in the drive housing. DO NOT get dirt on the flex cable.
4. Install the gear housing and shield assembly.

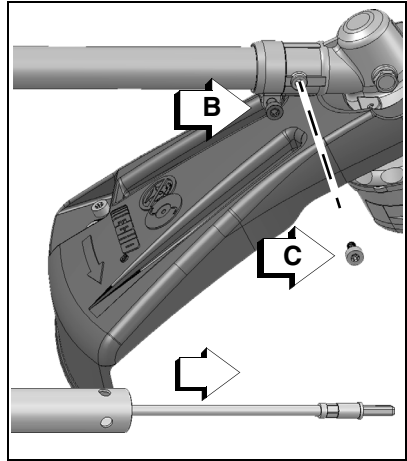

### Nylon Line Replacement

**CAUTION**

**Wear Gloves or personal injury may result:**

- ◆ **Cutoff knife is sharp.**
- ◆ **Gearcase and surrounding area may be hot.**

1. Do not push spool in. Hold drum (A) and turn spool (B) clockwise until peg clicks and disappears from hole. Pull spool out of drum.
2. Use one piece of new nylon line (C) 6 m (20 ft.) long and thread through the molded loop (D) on the spool. Pull line tight and adjust so one end is 15 cm (6 in.) longer than the other.

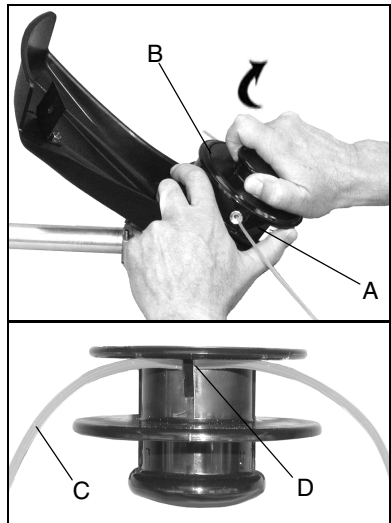

3. Hold the spool, opening toward you. Place index finger between the two strands and wind line, tightly and evenly, in direction of arrow (E).
4. Place ends of line into notches (F) in spool, leaving 6 in. protruding.
5. Feed ends of line outward through eyelets (G) in drum.
6. Align grooves in spool with pegs (I), and push spool (B), into drum.
7. Hold spool and drum securely with one hand, and pull each line to disengage from notches.
8. Hold drum (A) and turn spool (B) counterclockwise until peg clicks into hole.
9. Trim lines to 8 in. length.

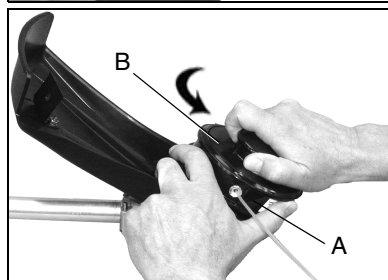
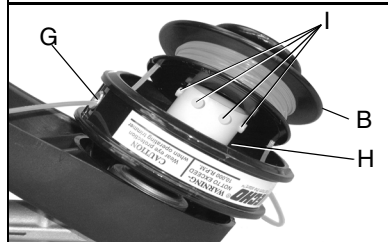
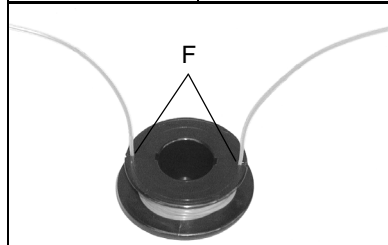
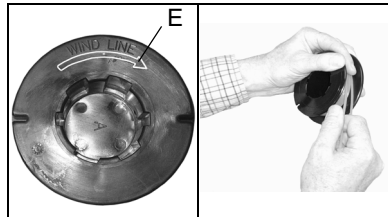

# STORAGE

## Storage Hook Installation

1. Insert small end of hook into locating hole on attachment shaft.
2. Slide plastic cap onto end of attachment shaft.

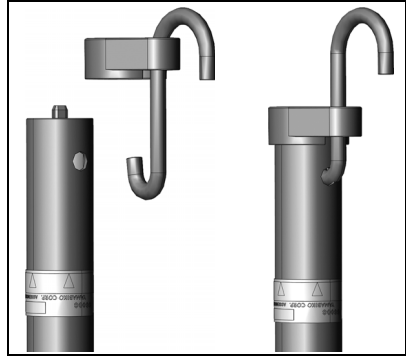

ENGLISH

## SPECIFICATIONS

<b>MODEL</b>	<b>99944200545</b>
Shaft Length	838 mm (32.99 in.)
Attachment Width	177 mm (6.97 in.)
Attachment Height	241 mm (9.49 in.)
Weight (dry) w/line head	1.18 kg (2.6 lb.)
Drive Shaft	6.35 mm (¼") Flex Shaft
Direction of Rotation	Counterclockwise viewed from the top
Gear Case Ratio	2.07:1
Cutter Head	Nylon line head with 095 in. line
Line Capacity	6 m (20 ft.)

---

## PRODUCT REGISTRATION

---

### Thank you for choosing ECHO Power Equipment

Please go to <http://www.echo-usa.com/Warranty/Register-Your-ECHO> to register your new product on-line. It's **FAST** and **EASY!** NOTE: your information will never be sold or misused by ECHO, Inc. Registering your purchase enables us to contact you in the unlikely event of a service update or product recall, and verifies your ownership for warranty consideration.

If you do not have access to the Internet, you can complete the form below and mail to:

***ECHO Inc., Product Registration, PO Box 1139, Lake Zurich IL 60047.***



PRODUCT REGISTRATION CARD : TARJETA DE REGISTRO : CARTE D'ENREGISTREMENT DU PRODUIT

**ONLINE OPTION:** Register online and save a stamp! You will be alerted of product updates and/or be sent new ECHO product information and special offers. Simply go to: [www.echo-usa.com](http://www.echo-usa.com)

**OPCIÓN POR INTERNET:** Regístrese en la página web y ahorre una estampilla! Le alertarán sobre actualizaciones del producto y/o se le enviará información sobre los nuevos productos ECHO y ofertas especiales. Simplemente visite: [www.echo-usa.com](http://www.echo-usa.com)

**OPTION EN LIGNE:** Enregistrer en ligne et épargner un timbre! Vous serez informé sur les nouveaux produits ECHO et les mises à jour de produit ainsi que les offres spéciales. Simplement visitez le: [www.echo-usa.com](http://www.echo-usa.com)

Please Print : Por Favor Enscriba Con Letra De Molde : En Lettre Carré S.V.P.

Confidential: Information provided will not be shared or sold

Purchaser's Name : Nombre del Comprador : Nom de l'acheteur	
Address : Dirección : Adresse	
City : Ciudad : Ville	Zip Code - Código Postal : Code Postal
State : Estado : Province	
E-Mail Address : Dirección De Correo Electrónico : Courriel Electronique	
Phone Number : Número De Teléfono : Téléphone	Date of Purchase : Fecha de la Compra : Date de l'achat
Where Purchased : Nombre del Almacén donde fue Comprado : Lieu d'achat	
Model Number : Numero del Modelo : No. de modèle	Serial Number : Numero de Serie : No. de série

Primary use of tool:  Professional  Homeowner  Rental Equip.  
 Uso primario de la herramienta:  Profesional  Dueño de casa  Alquiler  
 Usage principal:  Professionnel  Résidentiel  Location  
 Do you wish to receive periodic ECHO product information and special offers by e-mail?  Yes  No  
 ¿Desea usted recibir información periódica y ofertas especiales por correo electrónico sobre el producto ECHO?  Yes  No  
 Souhaitez-vous recevoir périodiquement de l'information sur les produits ECHO et les offres spéciales par courrier électronique ?  Oui  Non  
 Did you visit the ECHO website before purchasing your product?  Yes  No  
 Visité usted la página web ECHO antes de comprar su producto?  Si  No  
 Avez-vous visité le site d'ECHO avant de procurer votre produit?  Oui  Non

What factor(s) most influenced your purchase?  
 Performance  Price  Dealer  
 Reliability  Prior Experience  Quality  
 Friend/Family  Brand  Warranty  
 ¿Que factor(es) influenció más en su compra?  
 Funcionamiento  Precio  Distribuidor  
 Confiabilidad  Experiencia Anterior  Calidad  
 Amigo/Familia  Marca  Garantía

Which factor (factors) most influenced the plus?  
 Performance  Price  Marchand  
 Reliability  Experience  Qualité  
 Amis/Famille  Marque  Garantie

ECHO INC., 400 Oakwood Rd., Lake Zurich, IL 60047  
 1.800.432.ECHO [WWW.ECHO-USA.COM](http://WWW.ECHO-USA.COM)

X7572270206 02-2012

ENGLISH







S08900027801/S08900999999



**ECHO, INCORPORATED**

400 Oakwood Road  
Lake Zurich, IL 60047

[www.echo-usa.com](http://www.echo-usa.com)