



Volume 2

***YACHTLINE
360 / 400***

611 133 A



CAREFULLY READ THIS MANUAL BEFORE PUTTING YOUR ZODIAC INTO SERVICE.

VOLUME 2





DESCRIPTION - BUOYANCY TUBE PROPULSION SYSTEM INSTALLATION AND CIRCUITS

CONTENTS



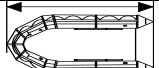
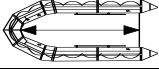

	PAGE
⇒ I - GENERAL DESCRIPTION	
I-1-Technical characteristics-----	2 - 3
I-2-Inventory-----	4 - 5
I-3-Location of parts-----	6 - 7
I-4-Handling-----	8 - 10
⇒ II - BUOYANCY TUBE	
II-1-Major stages in fitting the buoyancy tube-----	11
II-2-Installing the buoyancy tube on the hull-----	12 - 13
II-3-Inflation system-----	14
II-4-Pressure -----	14 - 16
⇒ III - PROPULSION SYSTEM	17
⇒ IV - INSTALLATION AND CIRCUITS	
IV-1-Fuel installation-----	18 - 20
IV-2-Electrical diagram-----	21
IV-3-Battery-----	22
IV-4-Storage of navigation light mast-----	23
IV-5-Connection of options-----	24 - 26
IV -6-Bilge pump operation-----	27





DESCRIPTION - TECHNICAL CHARACTERISTICS

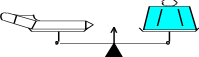

I-1-TECHNICAL CHARACTERISTICS

Dimensions			
		YL 360	YL 400
	(m)	3.60	4.00
	(ft)	11' 8"	13' 1"
	(m)	2	2.40
	(ft)	6' 7"	7' 10"
	(m)	1.77	1.77
	(ft)	5' 10"	5' 10"
	(m)	0.86	0.86
	(ft)	2' 10"	2' 10"
	(m)	0.455	0.455
	(ft)	1' 6"	1' 6"

Certification	
 (Directive 94/25/EU)	C

Capacity			
		YL 360	YL 400
 (ISO)		4	5
 Maximum	kg ⁽¹⁾	605	735
	lb ⁽¹⁾	1,334	1,621
	kg ⁽²⁾	200	218
	lb ⁽²⁾	441	481
 Compartment		3	3

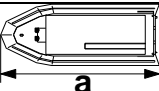
Engine			
		YL 360	YL 400
	Minimum recommended power	HP ⁽³⁾	15
		kW ⁽³⁾	12
	Maximum recommended power	HP	40
		kW	30
	Maximum allowed power	HP ⁽³⁾	40
		kW ⁽³⁾	30
 Maximum	Maximum engine weight	kg	119
		lb	262

Dimensions			
		YL 360	YL 400
	a ⁽⁴⁾	3.18 m	3.58 m
		10' 5"	11' 9"
	b ⁽⁴⁾	1.40 m	1.40 m
		4' 6"	4' 6"
	c ⁽⁴⁾	0.98 m	0.98 m
		3' 2"	3' 2"

DESCRIPTION - TECHNICAL CHARACTERISTICS

NOTE	Dimension tolerance: +/- 4%
-------------	-----------------------------

NOTE	<p>(1) The maximum payload has been calculated according to ISO 6185 standards. We recommend that you exercise caution when the boat is at maximum capacity.</p> <p>(2) The weights indicated do not include any accessories</p> <p>(3) The recommended power corresponds to optimal use of the boat's capacities for an average load (4 people).</p> <p>(4) Hull dimensions without buoyancy tube.</p> <p>Use the maximum authorized power with extreme caution (see "Recommended operating procedure" chapter of Volume 1 of the manual.)</p>
-------------	---

 WARNING	<p>The maximum load on the manufacturer's plate should not be exceeded. The maximum load includes the weight of the engine, fuel, accessories, passengers and their equipment and any other type of load.</p>
--	---

 WARNING	<p>Do not store flammable products in the rear compartment. It is strictly forbidden to store a spare fuel tank.</p>
---	--

ONLY ON 400DL:

 WARNING	<p>Limited manoeuvrability at speeds above 25 knots.</p> <p>Risk of loss of control in tight turns.</p> <p>Reduce speed* before turning in any direction.</p> <p>* you can also vary the power trim and move the engine closer to the transom.</p>
---	--

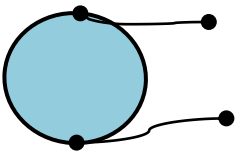
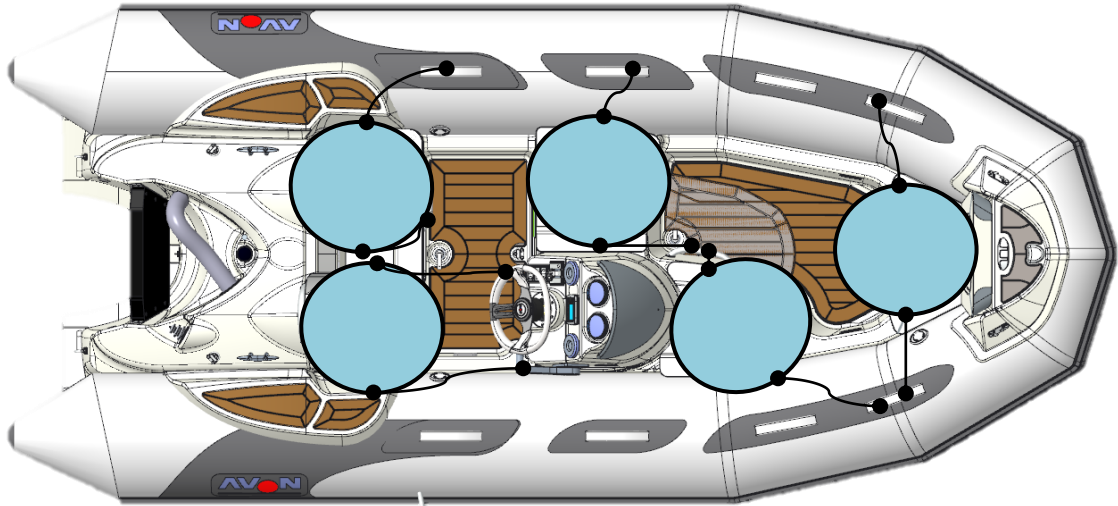

Seat with handles for the Yachtline 400

DESCRIPTION - INVENTORY

I-2-INVENTORY

HULL
• Polyester hull
• Counter-moulded, anti-slip deck
• Added transom and "flap" hull shape
• Console with storage
• 1 bow ring
• 1 anchor locker + locker forwards of the console (only on the 400 YL)
• 1 Aft locker
• 4 upholstered seats on YL 360 (5 seats on 400 YL)
• 2 aft anchoring cleats
• 1 front polyester step with cleat, navigation lights and LEDs
• 1 Folding and removable mast for white light
• 1 Deck light
• 3 Hinged lifting chain plates
• 2 Towing chain plates
• 2 Self-bailers + 1 Hull drain hole

BUOYANCY TUBE
• Removable buoyancy tube
• Hypalon-Neoprene 1100 decitex fabric
• Easy-Push valves
• Broad rubbing strip
• 6 Handles
• Cone reinforcements

CONSOLE
• Steering wheel and remote steering control
• 3 Switches
• Glove compartment

DESCRIPTION - Inventory

STANDARD EQUIPMENT
• 1 Fixed tank (35 litres + fuel gauge transmitter + water/fuel separator) with vent and anti-overflow device
• Navigation lights and deck lights
• 1 battery tray
• 1 battery isolation switch
• Pre-fitted electric equipment to add extra accessories
• 1 Bilge pump
• 2 Paddles
• 1 Foot inflator
• 1 Repair kit
• 1 Owner's manual (2 volumes)
• 1 Pressure gauge cap

OPTIONAL ACCESSORIES
• Lifting kit
• Boarding ladder
• Rear seatback
• Synthetic teak deck
• Wind deflector

DESCRIPTION – LOCATION OF ITEMS

I-3- LOCATION OF PARTS

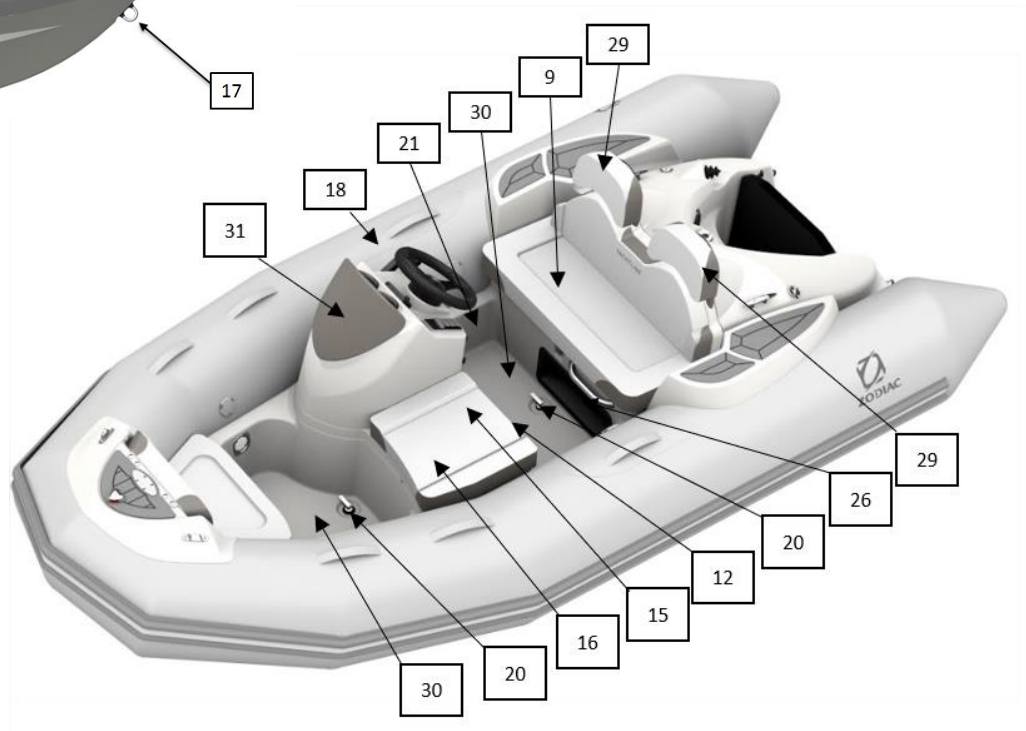
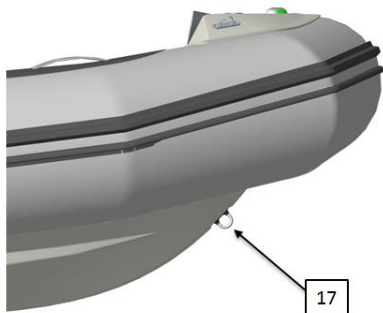
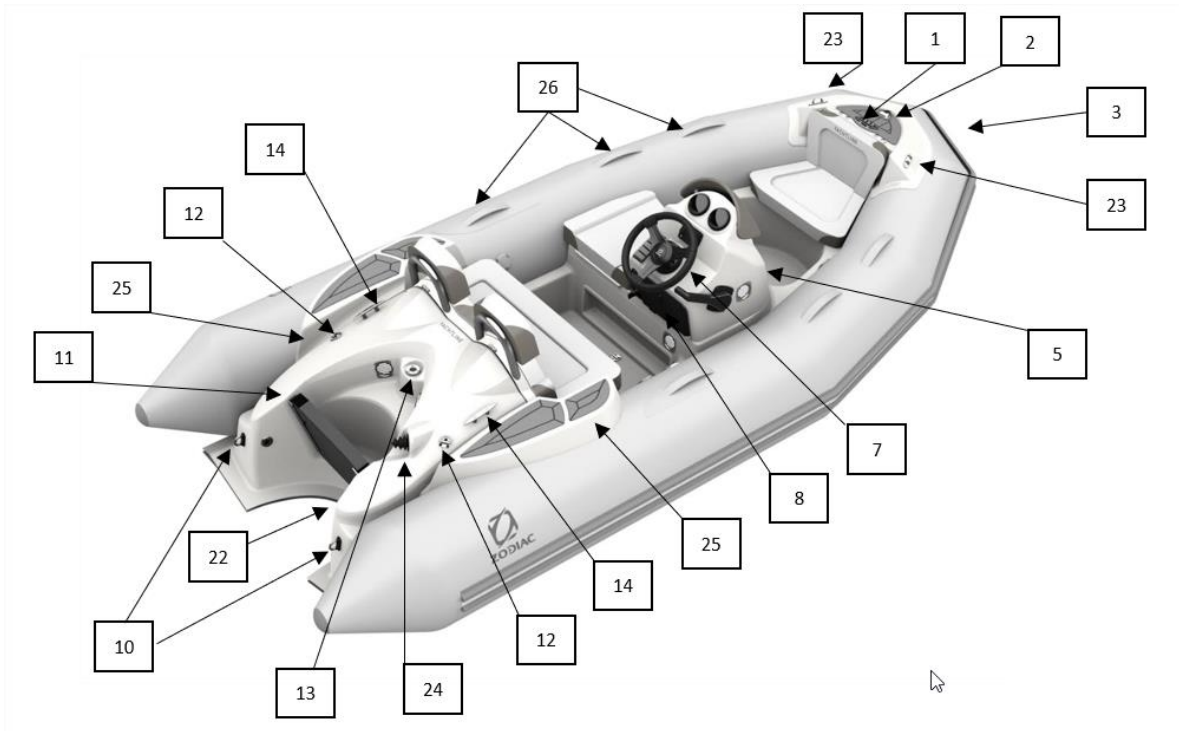

DESCRIPTION – LOCATION OF ITEMS

REF.	DESCRIPTION
1	Forward mooring cleat
2	Navigation lights
3	Front polyester step
4	Anchor locker
5	Console
6	Switches
7	Steering wheel
8	Glove compartment
9	Tilting aft seat
10	Towing / mooring rings
11	Transom
12	Lifting rings
13	Base of white light mast
14	Aft anchoring cleats
15	Tank filling system
16	Tank maintenance access hatch
17	Bow ring
18	Buoyancy tube
19	Fire extinguisher bracket
20	Self-bailer
21	Deck light
22	Scupper
23	Fairlead
24	Cable pull
25	Polyester step
26	Handle
27	Easy-Push valve
28	12V - cigarette lighter
29	Rear seatback
30	Synthetic teak deck
31	Wind deflector

DESCRIPTION - HANDLING

I-4-HANDLING

I-4-1 Transport:

- The trailer installation recommendations are specified in VOLUME I of the owner's manual.

I-4-2 Storage:

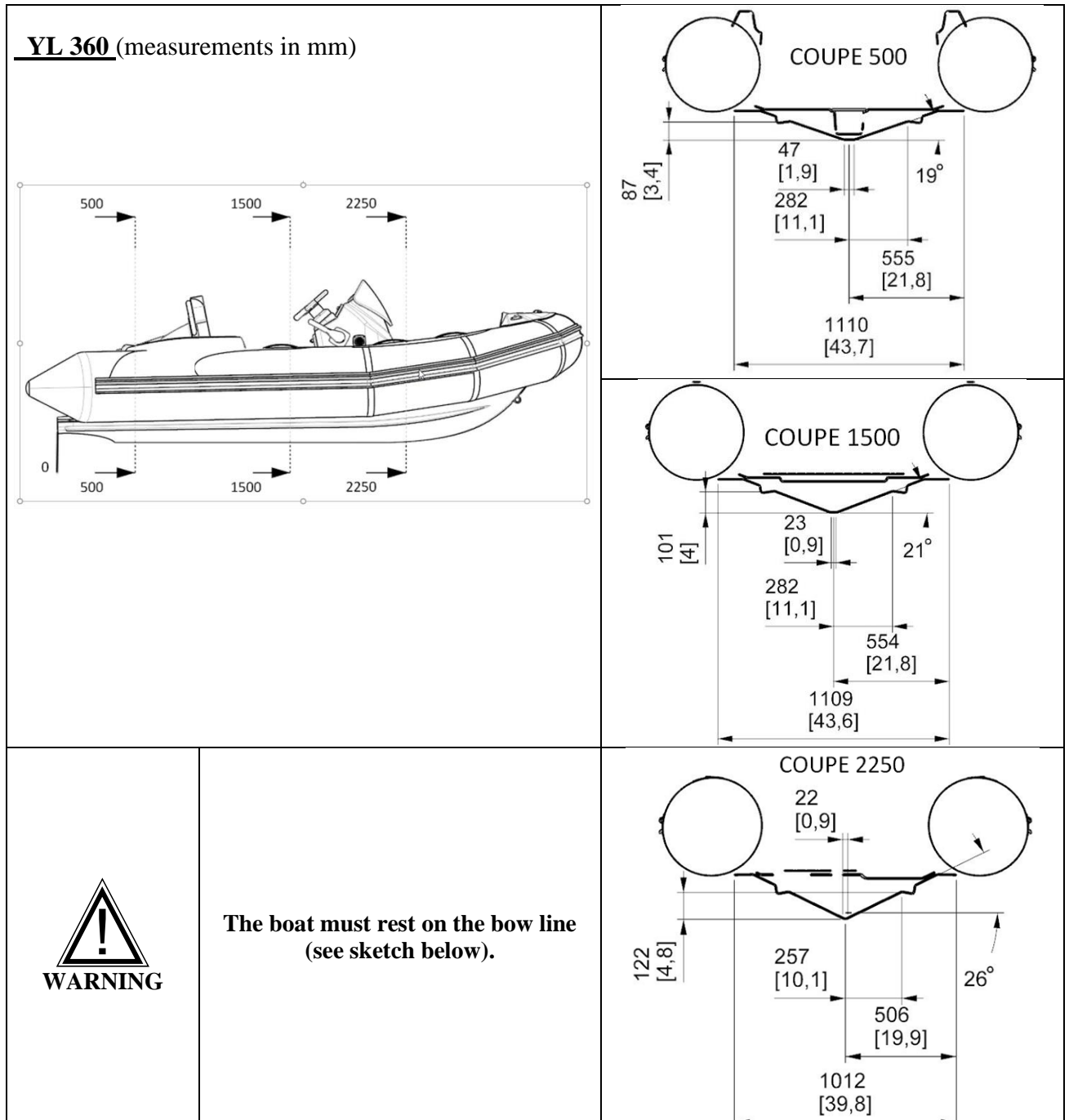

YL 400 (measurements in mm)

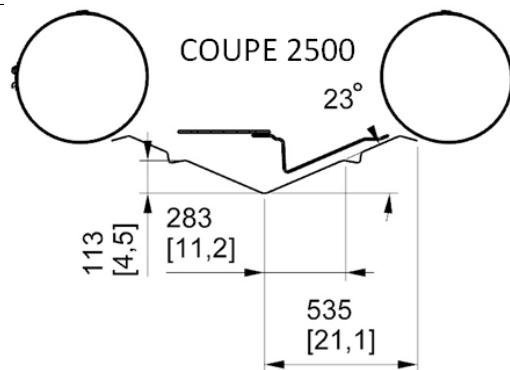
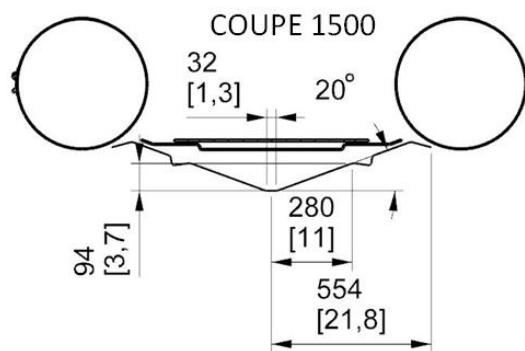
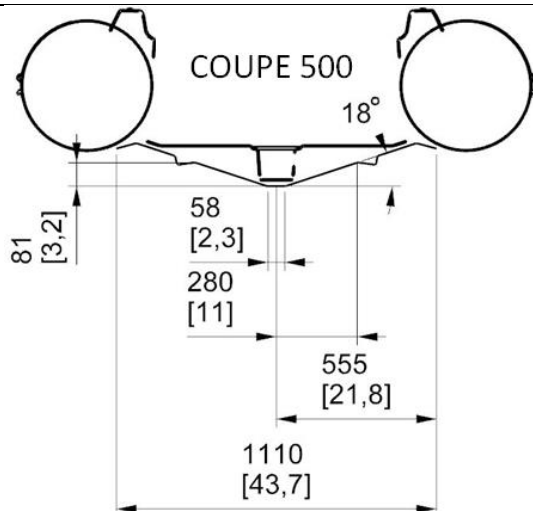
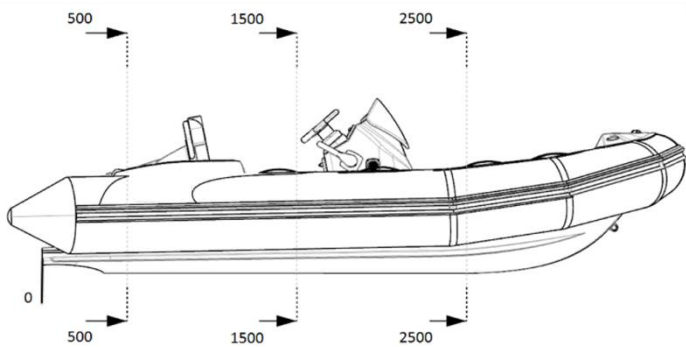

**The boat must rest on the bow line
(see sketch below).**

DESCRIPTION - HANDLING

I -4-3-Lifting:

 WARNING	<p>The lifting sling is available as an option; you must only use an AVON sling for lifting.</p>
---	--

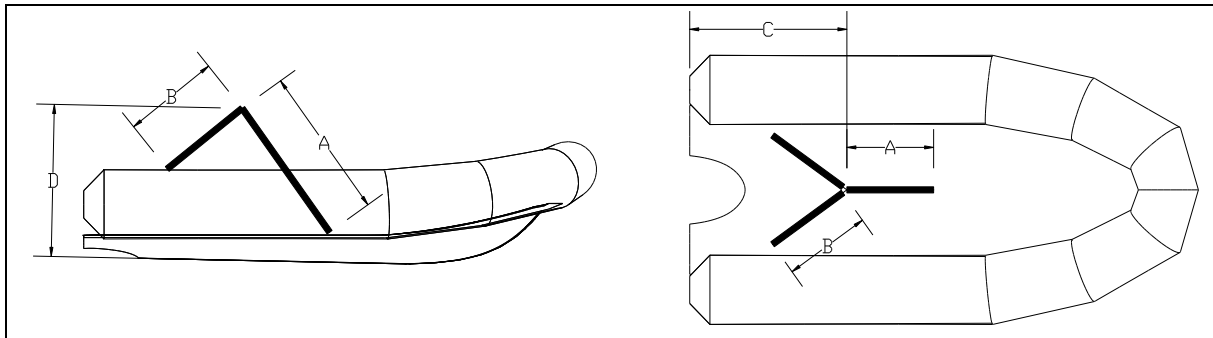

These values are an example		A	B	C	D
360 YL	(m)	1.25	1	1.45	1.4
	(ft)	4'1"	3'3"	4'8"	4'6"
400 YL	(m)	1.25	1	1.45	1.4
	(ft)	4'1"	3'3"	4'8"	4'6"

 WARNING	<p>No passengers on board while hoisting</p>
---	--

 CAUTION	<ul style="list-style-type: none"> All equipment must be unloaded from the boat for lifting or davit handling. The self bailer (item 20*) and the drain hole (item 22*) must be open to evacuate any rain water in the cockpit. <p style="margin-left: 20px;">* see chapter I-3 "Location of items"</p>
---	---

BUOYANCY TUBE – COMMISSIONING

II-1-FITTING THE BUOYANCY TUBE – MAIN STEPS

When assembling the boat, it is important that you follow the procedure in the correct order. Proceed step by step, checking the reference pages for procedure explanations.

PROCEDURE	PAGE	SECTION
1. inventory the parts of your boat and learn to recognize them	4-5	Inventory upon opening
	6-7	Location of items
2. fit the buoyancy tube on the hull	11	Installing the buoyancy tube
3. fit the internal protective flap	12	Fitting the protective flap
4. position the external protective flap		
5. place the valves in the inflation position	14	Inflation system
6. inflate the boat to the operating pressures	15	Inflating the boat
	16-17	Pressure
7. fit the external protective flap	12	Fitting the protective flap

BUOYANCY TUBE – COMMISSIONING

II-2 INSTALLING THE BUOYANCY TUBE ON THE HULL



IF THE BUOYANCY TUBE WAS STORED AT A TEMPERATURE BELOW 0°C / 32°F, LEAVE IT AT 20°C / 68°F FOR 12 HOURS BEFORE UNFOLDING.

NOTE

The buoyancy tube is fitted to the hull with the buoyancy tube **deflated**.

1

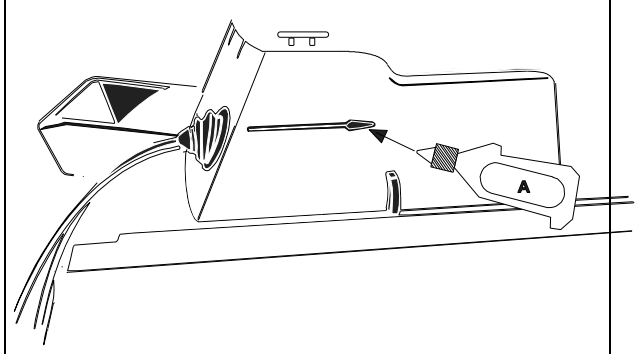
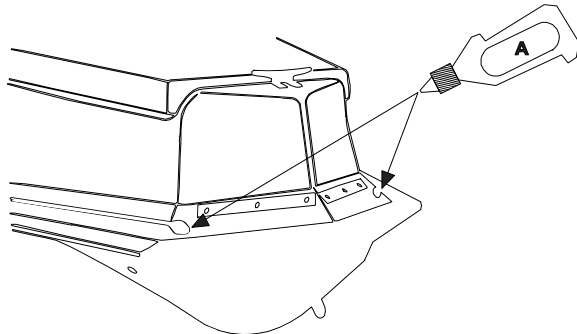

To facilitate the positioning of the buoyancy tube, apply liquid soap (A) to the hull rails.

2

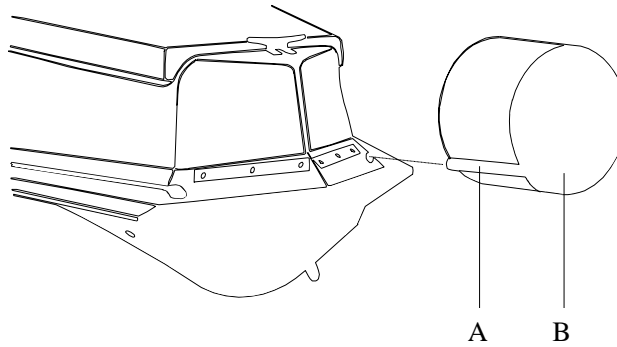

Position the buoyancy tube's (b) bolt rope (a) on the hull's rail.

3

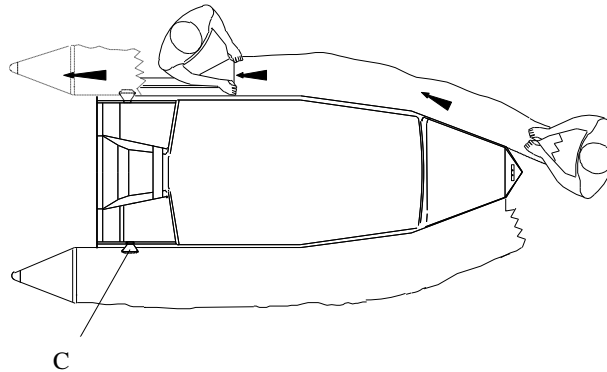

- Pull the buoyancy tube towards the boat's stern (Do not forget to guide the upper bolt rope C).
- Repeat for the other side of the buoyancy tube

BUOYANCY TUBE – COMMISSIONING

4

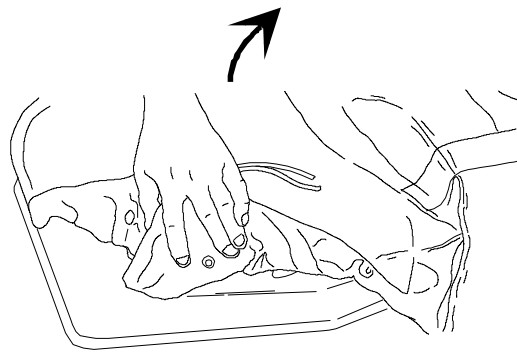

Install the internal rubber guard

5

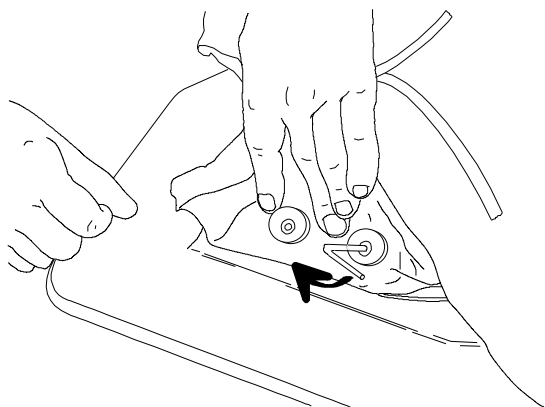

6

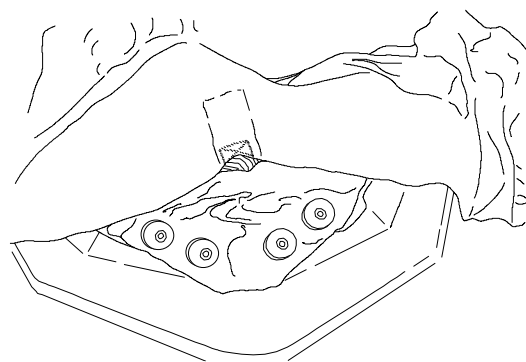

Fix the internal protective flap

7

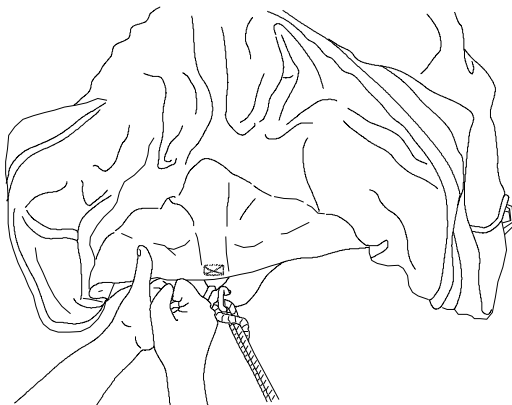

After fixing the internal protective flap on the hull, pull the buoyancy tube gently towards the forward section in order to send the external protective flap over the forward nose (do not attach it at this point). Then pull the buoyancy tube towards the aft end.

<p>NOTE</p>	<p>The external protective flap should be fixed after the buoyancy tube has been inflated</p>
--------------------	--

THEN BEGIN INFLATION

BUOYANCY TUBE – INFLATION SYSTEM

II -3-INFLATION SYSTEM

INFLATOR

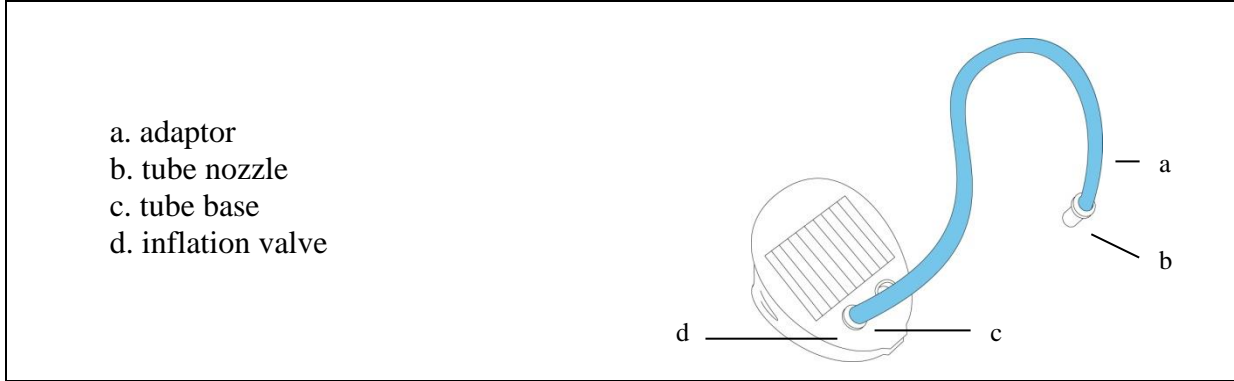

"EASY - PUSH" VALVES

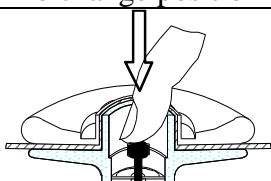
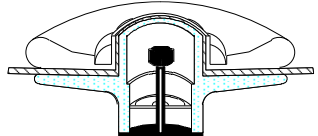
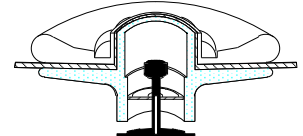
To change position	in inflating position	in deflating position
 Push	 The membrane is closed, the plunger is up	 The membrane is open, the plunger is down

BUOYANCY TUBE – PRESSURE

INFLATING THE ENGINE

Place all the valves in the inflation position.

Attach the hose connector to the inflation pump inflation port.
 To inflate your boat properly, the inflation pump should be correctly placed on the ground.
 The boat inflates rapidly if the inflation pump is used smoothly and without haste.

 WARNING	<p>Do not use a compressor or compressed air cylinder.</p>
---	---

BUOYANCY TUBE - PRESSURE

INFLATING THE BUOYANCY TUBE

- Place the adapter corresponding to the diameter of the semi-built in valve at the inflation pump hose nozzle.
- Inflate the buoyancy tube, **balancing the pressure between the different compartments until the partitions (a) are no longer visible (pressure = 240 mb)**

	<p>Never put a compartment under pressure while the others are still fully deflated.</p>	
--	--	--

	1	
--	---	--

	2	
--	---	--

Inflation is completed: Screw on the inflation valve plugs.

NOTE:	<p>A slight loss of air is normal before the cap is screwed on. Only the plugs provide final airtightness.</p>
--------------	--

BUOYANCY TUBE - PRESSURE

CORRECT PRESSURE

The correct pressure for the buoyancy tube is 240 mb/ 3.4 PSI.

The ambient temperature of the air or the water proportionally influences the internal pressure of the buoyancy tube:	Ambient temperature	Pressure inside the buoyancy tube
	+ 1°C	+ 4 mb / + 0.06 PSI
	- 1°C	- 4 mb / - 0.06 PSI

Thus it is important to anticipate:
Check and adjust the pressure of inflatable compartments (by inflating or deflating) depending on the temperature (particularly when temperature variations are high)

between the morning and evening in hot regions) and check that the pressure does not leave the recommended pressure zone (from 220 to 270 mb / green zone).

LOW PRESSURE RISK:

Example: Your boat is exposed to direct sunlight on the beach (temperature=50°C) at the recommended pressure (240 mb/3.4 PSI). When you launch the boat (temperature = 20°C), the temperature and pressure in the inflatable compartments will jointly drop (up to 120 mb) and **you must then re-inflate** them until the millibars lost due to the difference between air and water temperature are regained. It is normal to observe a drop in pressure at the end of the day when the outdoor temperature drops.

RISK OF OVERPRESSURE:

EXAMPLE: Your boat is inflated to its recommended pressure (240 mb/3.4 PSI) at the beginning or end of the day (low outside temperature = 10°C). Later in the day, your boat is left in the sun on the beach or on the deck of a boat (temperature = 50°C). The temperature inside the inflatable compartments may rise to 70°C (particularly for dark buoyancy tubes), doubling the initial pressure (480 mb). **You must then deflate** the boat to return to the recommended pressure.



If your boat is overinflated, the pressure will abnormally wear the inflatable structure which may lead to a breach of the assembly.

BUOYANCY TUBE - PRESSURE

IN THE EVENT OF OVERPRESSURE

EASY-PUSH VALVE:
Release air by pressing the valve plunger

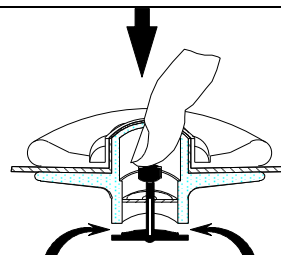

PROPULSION SYSTEM

III - Propulsion system

Comply with Zodiac's recommendations and with the engine manufacturer's recommendations.

For optimal use of your boat, please consult your dealer.

INSTALLATION AND CIRCUIT - FUEL

IV-1-Fuel installation

IV-1-1-Fuel tank

The tank is located under the steering console:

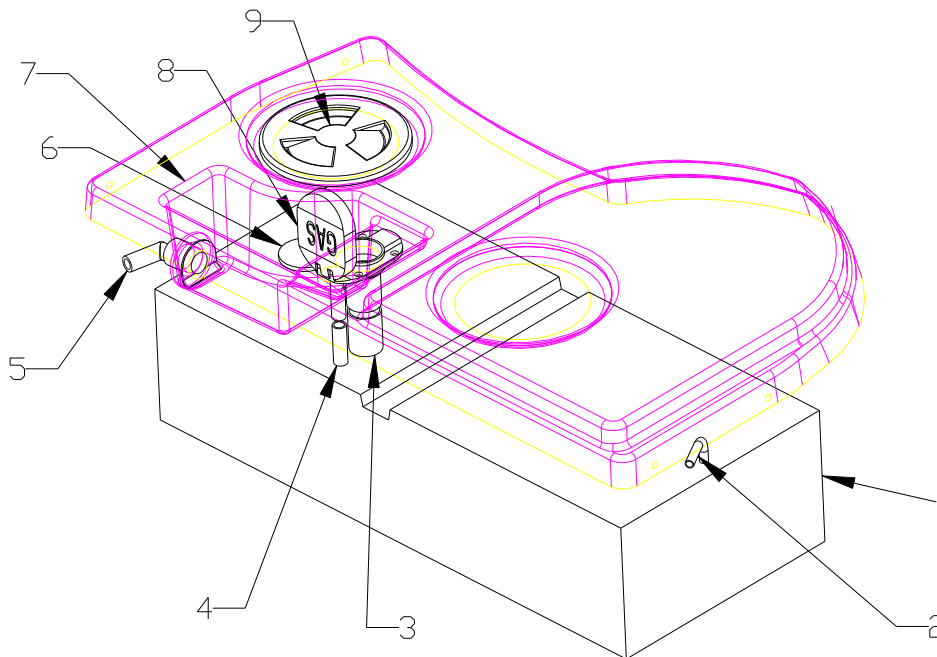

REF.	DESCRIPTION
1	Tank
2	Outlet for fuel supply to the engine
3	Filling hole
4	Vent
5	Overflow compartment drain hole
6	Gauge transmitter
7	"Overflow" compartment
8	Filler cap with integrated vent
9	Tank maintenance hatch

 WARNING	<p>It is vital to have a gauge dial. It is supplied with the engine. If your boat does not have one, contact your dealer.</p>
---	--

The probe supplied is to American standard:

Impedance (tank empty position) 30 Ohms

Impedance (tank full position) 240 Ohms

All the dials on the market are compatible, with a few very rare exceptions

To connect it, refer to the electrical diagram page 22.

INSTALLATION AND CIRCUIT – TANK AND ACCESSORIES

IV-1-2-Fuel/water separator filter

NOTE:	In order to protect the engine, a water / fuel separating filter is placed on the engine’s fuel supply system.
--------------	---

The water/fuel separator filter is located in the aft locker, on the starboard partition:

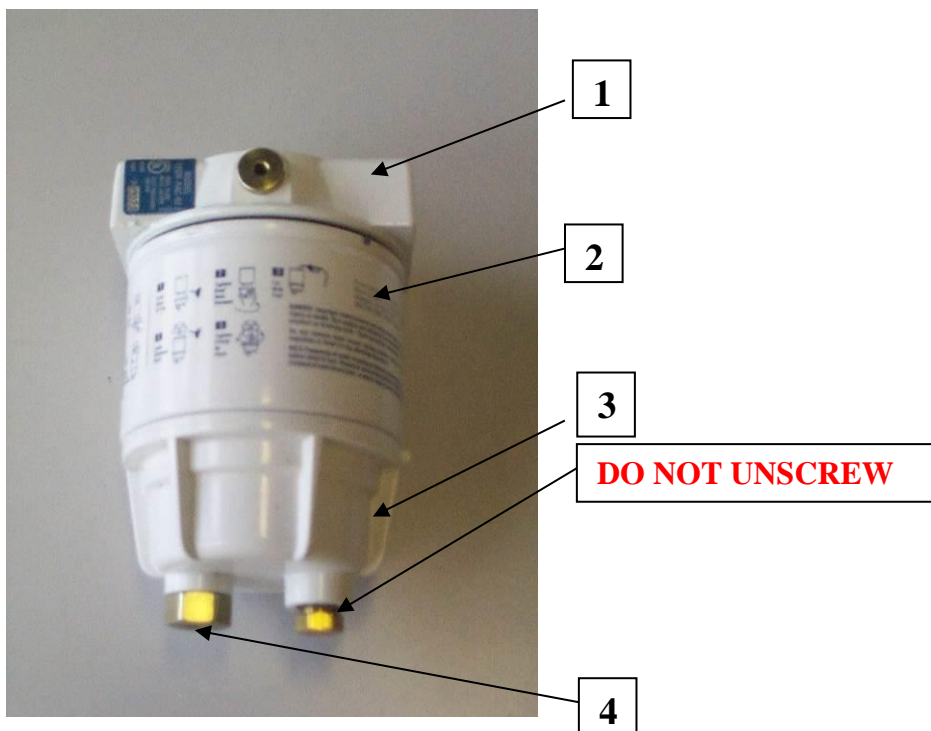

REF.	DESCRIPTION
1	Filter head, secured to boat
2	Replaceable filter cartridge
3	Metal bowl
4	Purge screw

 WARNING	Doing so could damage the seal and compromise the tightness of the bowl
--------------------	--

NOTE	Make sure that there is no water in the metal bowl each time you use your boat: Slightly unscrew the drain plug (do not remove it completely); drain the water; screw the plug back in if only fuel remains in the bowl. Do this more often if your engine is not functioning correctly.
-------------	---

INSTALLATION AND CIRCUIT – TANK AND ACCESSORIES

 WARNING	<p>It is vital to drain and clean the filter regularly and to change the cartridge at least once a year. The metal bowl can be reused.</p>
---	---

Changing the filter cartridge:

Follow ZODIAC's recommendations and those of the filter manufacturer.

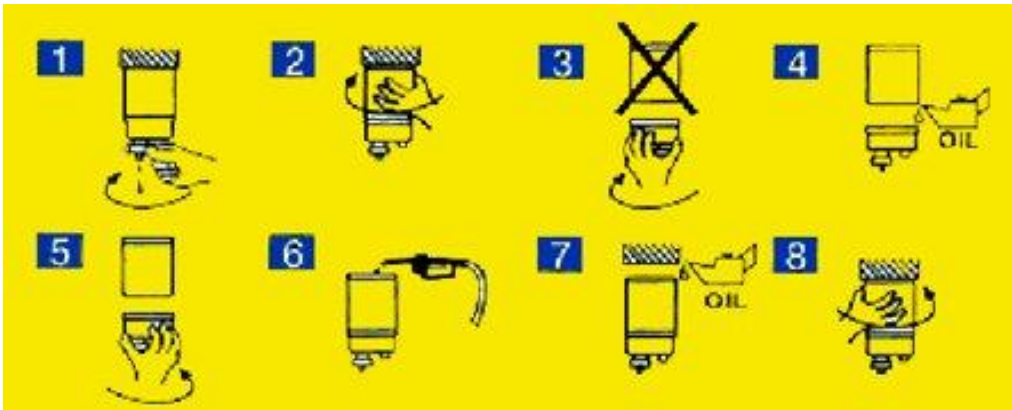

IV-1-3-Recommendations:

 WARNING	<ul style="list-style-type: none"> <input checked="" type="checkbox"/> ENSURING THAT THE FUEL TANK IS FULL BEFORE EACH OUTING PREVENTS CONDENSATION FROM FORMING. <input checked="" type="checkbox"/> HAVE THE TANK CLEANED EVERY 5 YEARS. <input checked="" type="checkbox"/> Check that all hose clamps are tight. <input checked="" type="checkbox"/> When you drain the filter, do not empty the water into the boat. Place a recovery tray under the filter. <input checked="" type="checkbox"/> SHUT OFF THE POWER SUPPLY BEFORE REMOVING THE FILTER CARTRIDGE. <input checked="" type="checkbox"/> Carefully read the information provided in the filter's instruction manual.
---	---

 WARNING	<ul style="list-style-type: none"> <input checked="" type="checkbox"/> Petrol is extremely flammable. Make sure that the engines are turned off before working on the fuel system. Do not smoke; keep all flames or incandescent material well away from the work area.
---	---

INSTALLATION AND CIRCUIT - ELECTRICITY

IV -2-ELECTRICAL DIAGRAM

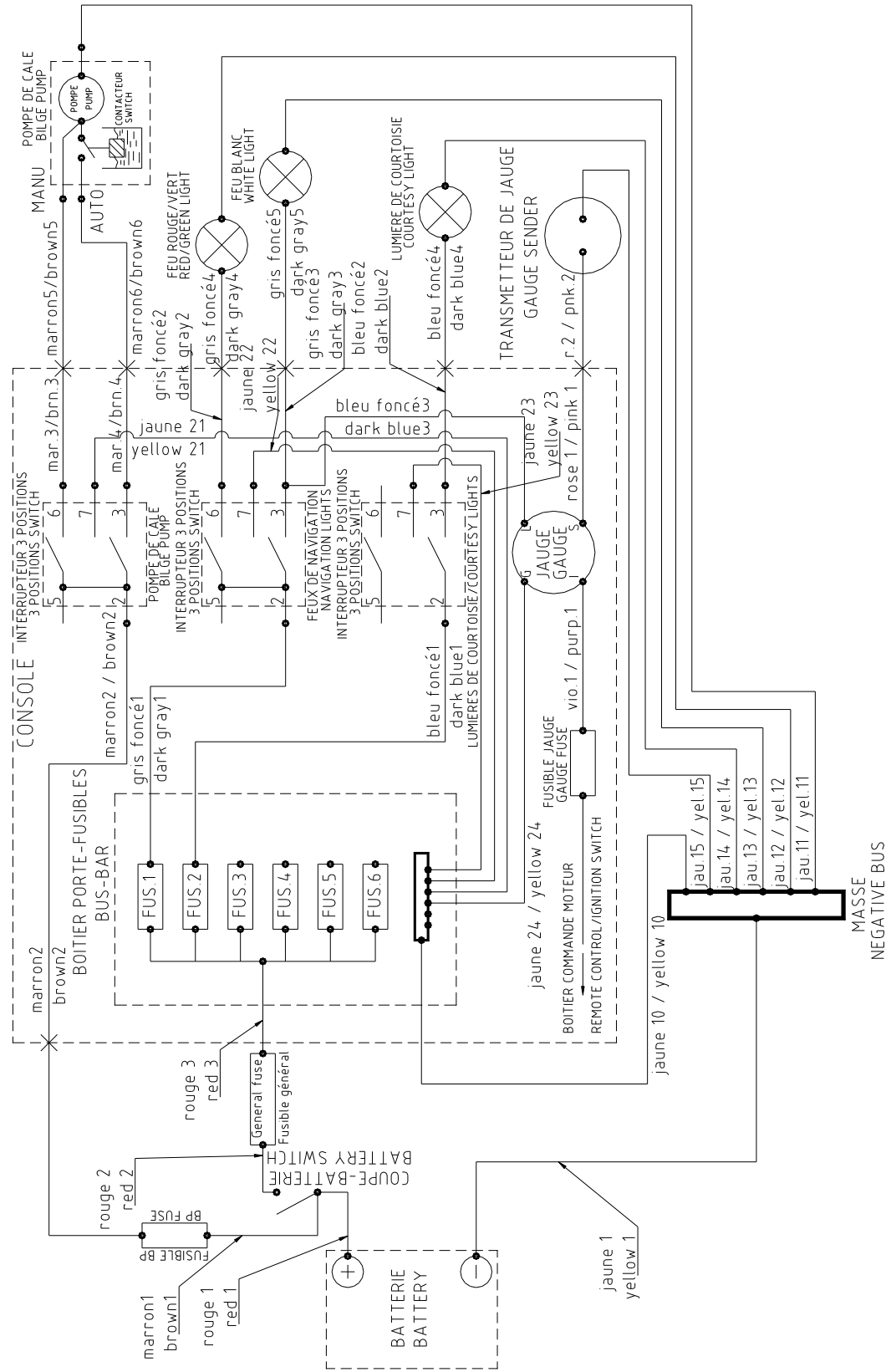



INSTALLATION AND CIRCUIT – CONNECTION of options

IV -3-BATTERY (not supplied)

Comply with Zodiac's recommendations and with the recommendations of the battery manufacturer for standard maintenance.

	<p>Maintain your battery:</p> <ul style="list-style-type: none"> <input checked="" type="checkbox"/> KEEP THE BATTERY CLEAN AND DRY IN ORDER TO AVOID PREMATURE WEAR. <input checked="" type="checkbox"/> Tighten and maintain the terminal lugs by greasing them regularly.
---	---

 WARNING	<p>The water from the water supply system contains mineral which damages batteries. You should thus always top up with distilled water.</p>
 WARNING	<ul style="list-style-type: none"> • Keep the batteries and the electrolyte out of the reach of children • Always keep the battery upright, never on its side. • When adding electrolyte or when recharging the battery, always remove it from the engine compartment • Battery electrolyte is a toxic and dangerous liquid. It contains sulphuric acid which can cause serious burns. Avoid contact with skin, eyes and clothes. • Batteries can emit explosive gases. Keep them away from sparks, open flames, cigarettes, etc. • When charging or using a battery, work in a well-ventilated environment. Always protect your eyes when working close to a battery.

NOTE:	<ul style="list-style-type: none"> <input checked="" type="checkbox"/> IF YOU DO NOT PLAN TO USE YOUR ZODIAC® FOR A MONTH OR MORE, REMOVE THE BATTERY AND STORE IT IN A COOL, DARK AND DRY PLACE. Fully recharge the battery before reusing it. <input checked="" type="checkbox"/> IF THE BATTERY IS BEING STORED FOR A LONGER PERIOD, CHECK ELECTROLYTE DENSITY AT LEAST ONCE A MONTH AND RECHARGE THE BATTERY AS SOON AS THE DENSITY IS TOO LOW. <p>Electrolyte density: 1.28 at 20°C</p>
--------------	--

NOTE:	<p>When you stop using the boat, set the circuit-breaker to OFF.</p>
--------------	--

INSTALLATION AND CIRCUIT – CONNECTION of options

IV-4-STORAGE OF NAVIGATION LIGHT MAST



 <p>WARNING</p>	<p>To not damage the navigation light mast when closing the seat, always stow it as shown on the photo above.</p>
---	---

<p>NOTE</p>	<p>To facilitate fitting the mast in the fittings, you may use soapy water.</p>
--------------------	---

VIEW FROM ABOVE:

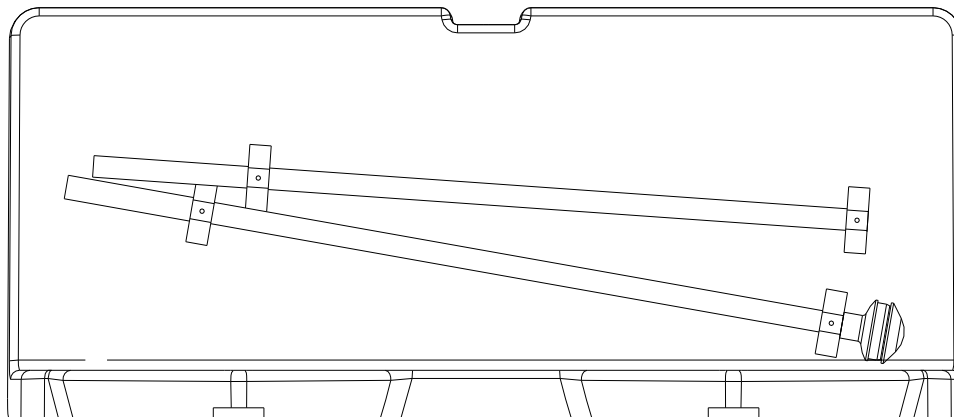

INSTALLATION AND CIRCUIT – CONNECTION of options

IV -5-CONNECTION OF OPTIONS

IV-5-1-Precautions:

The boat is provided as standard with a bilge pump, navigation lights and a deck light. However, 4 locations remain available on the fuse box (under the console) for the connecting of additional accessories under certain conditions:

- ① The accessories you want to add must be connected to the console.
- ② Accessories are divided into two categories:
 - A** → Accessories that are used or which may be used continuously during normal use of the boat,
 - B** → Accessories that are used intermittently.

A	and	B	
Bilge fan		Cigarette lighter connector	
Radio		Miscellaneous lighting	
Depth sounder		Horn	
GPS		Miscellaneous electronic equipment	
Searchlight		Shower pump	
Alarm system		Max. power	72 W max.
Refrigerator			
VHF			
Σ			180 W max.

 WARNING	<p>You must make sure that the total power of the accessories you add in column A is 180 W (15 A) or less AND that the max power of an accessory in column B is 72 W (6 A) or less.</p> <p>The cross-sections of the different cables in the wiring circuit were calculated using these figures; not following this rule may lead to electrical faults and cause short circuits.</p>
---	--

NOTE:	<p>If you are getting several pieces of electrical equipment installed. The total immediate consumption could potentially exceed your outboard motor's capacity. For example, the electrical wiring harness can accept instant consumption of 285W (including navigation lights and bilge pump), which is a little less than a 24 A output current. The alternators in the current engines generally provide 15 A when at full throttle (Check your engine's technical documentation). You should therefore avoid using this equipment over a long period of time, as you run the risk of draining the battery and not being able to restart the engine.</p>
--------------	---

INSTALLATION AND CIRCUIT – CONNECTION of options

Example 1

You want to add:
 A 72 W VHF,
 A 36 W GPS,
 A 60 W radio,
 A 72 W cigar lighter,
 A 20 W clock.

A	
Bilge fan	
Radio	60 W
Depth sounder	
GPS	36 W
Searchlight	
Alarm system	
Refrigerator	
VHF	72 W
Σ	168 W (<180 W) ☺

and

B	
Miscellaneous lighting	
Miscellaneous electronic equipment	20 W (clock)
Shower pump	
Max. power	20 W (< 72 W) ☺

CONCLUSION	
------------	--

Example 2

You want to add:
 A 60 W VHF,
 A 36 W GPS,
 A 48 W radio,
 A 120 W searchlight.

A	
Bilge fan	
Radio	48 W
Depth sounder	
GPS	36 W
Searchlight	120 W
Alarm system	
Refrigerator	
VHF	60 W
Σ	264 W (> 180 W) ☹

and

B	
Miscellaneous lighting	
Miscellaneous electronic equipment	
Shower pump	
Max. power	0 (< 72 W) ☺

CONCLUSION	
------------	--

INSTALLATION AND CIRCUIT – CONNECTION of options

Example 3

You want to add:

- A 60 W GPS,
- A 60 W radio,
- A 120 W horn.

A	
Bilge fan	
Radio	60 W
Depth sounder	
GPS	60 W
Searchlight	
Alarm system	
Refrigerator	
VHF	
Σ	120 W (< 180 W) ↻

and

B	
Miscellaneous lighting	
Miscellaneous electronic equipment	120 W
Shower pump	
Max. power	120 W (> 72 W) ⚡

CONCLUSION	
------------	--

NOTE	Some manufacturers will indicate the amperage rather than the absorbed power. With direct current from a 12 V battery, as is the case here, simply multiply by 12 to obtain the power.
-------------	---

IV -5-2-Wiring:

- ① Choose a free fuse location.
- ② Connect the power supply of your accessory to the terminal corresponding to this slot using a 6mm female tab type terminal lug.
- ③ If you have to add cable for the connection, use cable with a cross-section of at least 1.5mm² that complies with "marine" standards (UL1426 or SAE J378 or SAE J1127 or SAE J1128 or more generally meeting ABYC and/or EC standards),
- ④ Connect the earth cable of your accessory to the ground terminal strip using a Ø5 "ring terminal" (same comment as for the cable above),
- ⑤ Insert an ATO type fuse with a max current of 15A and greater than the load current of your device.

IV -5-3-Connecting the petrol gauge:

Connect as shown in the diagram (page 19).

INSTALLATION AND CIRCUIT – CONNECTION of options

IV -5-4-Connecting accessories on the console:

Depending on the level of equipment of your tender, Zodiac recommends placing it in the following manner (see templates supplied with the boats) which optimises the space available.

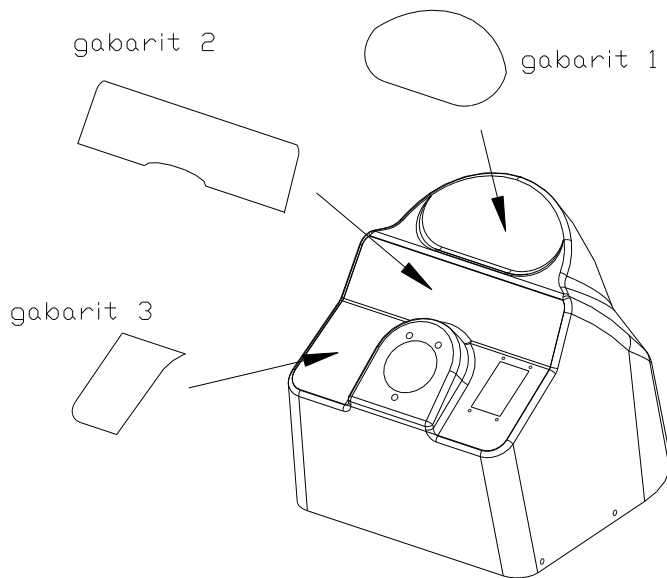

IV -6-BILGE PUMP OPERATION

The bilge pump is not wired to the battery switch and operates independently; the control switch  is always ON.

- ① Automatic operation (set position): in this position, the bilge pump operates automatically. The indicator light is on.
- ② Off: in this position (set position), the bilge pump is off. The indicator light is off.
- ③ Forced operation: the switch has to be held depressed to operate it. As soon as you release the switch, it returns to the Stop position (2).

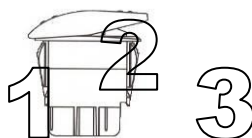
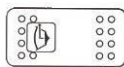



WARNING

At anchor, set the bilge pump switch to the automatic position.

NOTE

Zodiac recommends the use of a tarpaulin or mooring cover in order to prevent water ingress in the event of rain.



WARNING

Your attention is drawn to the finishing process in which structural components such as steering consoles, seats and superstructure elements are installed by parties other than the manufacturer. These elements should be installed in compliance with the relevant requirements of ISO 6185-3 to ensure that all such installations do not invalidate the initial assessment.

Also ensure that the subsequent installation of consoles and other structural elements not initially supplied with the boat is performed in accordance with the installation recommendations provided by the manufacturer and ZODIAC's recommendations.



Z NAUTIC GROUP
2 chemin de la Val Priout
31450 AYGUESVIVES
FRANCE

YACHTLINE 360 - 400