

PRODUCT INFORMATION



DF140A/115A

LEAN BURN 

Maximizing Fuel Economy, Maximizing Performance

Suzuki engineers have delivered a pair of outboards that offer the great fuel economy without sacrificing on performance and employ advanced technologies that Suzuki has pioneered over the last decade. The DF140A and DF115A incorporate the Suzuki Lean Burn System—the same system that has been delivering remarkable fuel economy on Suzuki's award winning flagship, the DF350AP, as well as the DF9.9B/20A/15A through DF300AP outboards.

The Suzuki Lean Burn System allows the engine to operate on a leaner, more efficient fuel mixture providing significant improvements in fuel efficiency while still providing the power. These engines also incorporate an O₂ Sensor Feedback System that keeps emissions cleaner and more stable, thus reducing impact on the environment. All three outboards feature new engine covers designed with an aggressive, progressive and powerful form that proudly carry Suzuki's "S" mark embossed on the front.

Suzuki outboards are built with decades of experience in the design, development, and manufacture of motorcycle, automobile, and marine engines. Built with the needs of today's boaters in mind to help you go farther, faster, for less.





Main Features of the DF140A/115A

- 124.7 cu.in. DOHC 16-valve High Performance Engine
- Suzuki Lean Burn Control System
- O₂ Sensor Feedback Control System
- Knock Sensor
- Suzuki Water Detecting System
- Multi-Point Sequential Electronic Fuel Injection
- Suzuki Troll Mode System (Optional)
- Multi function tiller handle (DF115A Optional)

Suzuki Lean Burn Control System

Recognizing a need for more fuel-efficient outboards, Suzuki developed and introduced its innovative Suzuki Lean Burn Control System on the DF90A/70A outboards, which received great acclaim from boaters and the media alike. The system predicts fuel needs according to operating conditions allowing the engine to run on a more efficient fuel mixture through the use of a lean air to fuel ratio. Its benefits are delivered over a wide operating range providing significant improvements in fuel economy from low-speed operation up into the cruising range. In-house testing shows that while cruising, the new DF140A is 14% more economical than its predecessor without sacrificing any of the original DF140's power.



O₂ Sensor Feedback Control System

Like Suzuki's flagship DF350A, the DF140A/115A feature an O₂ Sensor Feedback Control system that keeps emissions cleaner and more stable. By controlling the air to fuel ratio across each of the engine's operating ranges, the system provides an optimum amount of fuel to the engine regardless of rpm.

Cleaner, More Efficient Operation

Suzuki utilizes a number of its advanced technologies to deliver cleaner, more efficient operation that conforms to the Recreational Craft Directive (RCD) – Directive 2003/44EC of the European Parliament and of the Council, and has received three-star ratings from the California Air Resources Board (CARB).



EURO 1 Emissions Standards
(EU Directive 2003/44/EC) Label



CARB Three-Star Label

Comparison of Fuel Consumption per 1 Liter of Fuel
(New DF140A vs. Original DF140)

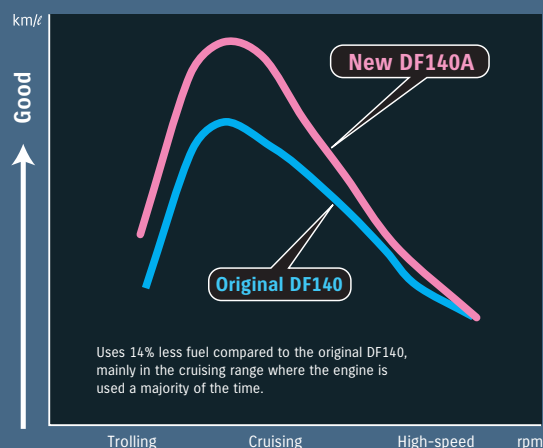

Data used in the graphs were obtained through in-house testing under unformed conditions. Results will vary depending upon operating conditions (boat design, size, weight, weather, etc.)

DOHC 4-Valve Engine

Suzuki has a long history of designing and manufacturing engines for motorcycle, automobile, and marine use. Drawing upon this unrivaled experience Suzuki engineers have designed an in-line four cylinder engine that delivers high power output, high performance, excellent fuel economy, and efficient operation. With a displacement of 124.7 cu.in., the in-line four-cylinder block is topped with a high performance 16-valve, dual overhead cam (DOHC) powerhead.

Obtaining Maximum Performance

The DF140A and DF115A utilize an enhanced air intake system that maximizes airflow into the engine to obtain greater power output. In order for this system to achieve full potential, greater exhaust efficiency is required as well, so the engines are designed with an efficient “4 into 2 into 1” exhaust system that reduces drag in the exhaust letting it flow smoothly out of the cylinders. This design increases low to mid-range torque on these outboards and provides the wide powerband that boaters want.

The DF140A/115A also feature a two-stage reduction gear that delivers the torque needed to turn a large diameter propeller. This is normally done using larger gears or a larger gearbox, but Suzuki has long employed a two-stage system that provides the required torque without adding unwanted bulk or weight to the engine. With a final drive ratio of 2.59, these outboards produce plenty of torque for quick acceleration.

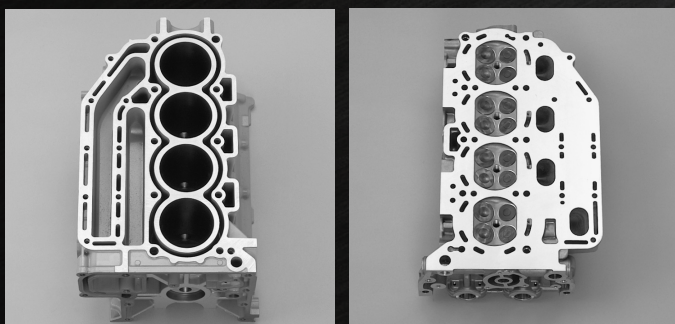

Cylinder Block

Cylinder Head

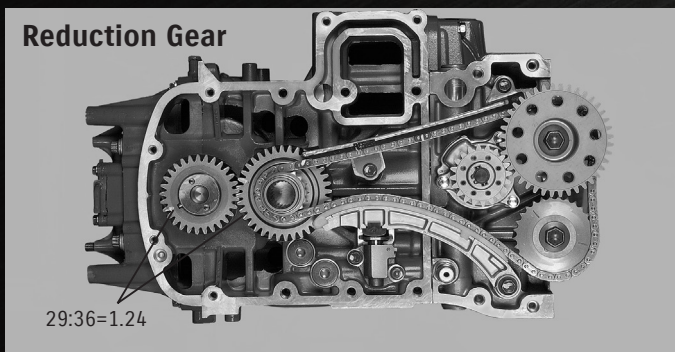

Reduction Gear

29:36=1.24

Both models also feature a two-stage reduction gear that delivers a larger gear ratio of 2.59. On the drive shaft, the first stage reduction delivers a ratio of 1.24 while the second stage, in the gear case itself, delivers a further reduction of 2.08. The biggest gain this system delivers is in its capability to use a highly efficient, large pitch, large diameter propeller.

New Engine Cover Design

The DF140A/115A feature all new engine cover designs that deliver an aggressive and powerful look. Going beyond looks, their designs are the result of research by Suzuki engineers on delivering maximum cooling efficiency for the engine—an excellent integration of form and function.



Offset Driveshaft

Suzuki outboards from the DF70A up incorporate an offset driveshaft that positions the powerhead forward of the drive shaft. This configuration moves the outboard's center of gravity forward resulting in better weight distribution on the transom and contributes to directional stability. The offset driveshaft also moves the axis of inertia, the point where vibrations are produced, up over the engine mount, which reduces engine vibration.

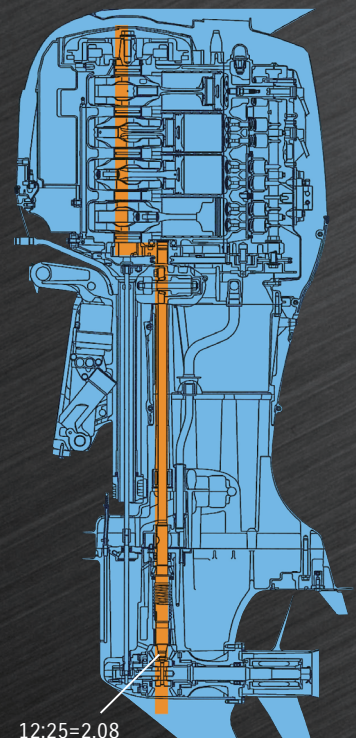

12:25=2.08

Knock Sensor (DF140A/115A)

The DF140A and DF115A are the Suzuki's first four-cylinder outboards featuring a knock sensor. Found on some V6 models, this system is used to detect and control abnormal combustion allowing the engine to operate at optimum performance. The system increases engine durability and helps deliver maximum power.

Suzuki Water Detecting System

Water in the fuel can lead to problems that include poor combustion, lower power output, and corrosion. The Suzuki Water Detecting System is designed to help protect the engine from moisture in the fuel utilizing a water detecting fuel filter to alert the operator with both visual and audio warnings when water is present in the fuel. The filter also designed to let you check for water visually.



Multi-Point Sequential Electronic Fuel Injection

Multi-Point Sequential Electronic Fuel Injection is Suzuki's sophisticated fuel injection system found on Suzuki outboards from the DF40A to DF 350A. The system uses a 32-bit computer in the electronic control unit to monitor vital operating data gathered from a series of sensors located in critical areas on the engine.

Processing this data in real time, the system automatically calculates the optimum amount and exact timing of fuel to be injected at high pressure into the combustion chamber. Benefits include smoother and faster acceleration, crisp throttle response, maximum fuel economy, low emissions, and quick, reliable starts.

Multi Point Sequential Electronic Fuel Injection

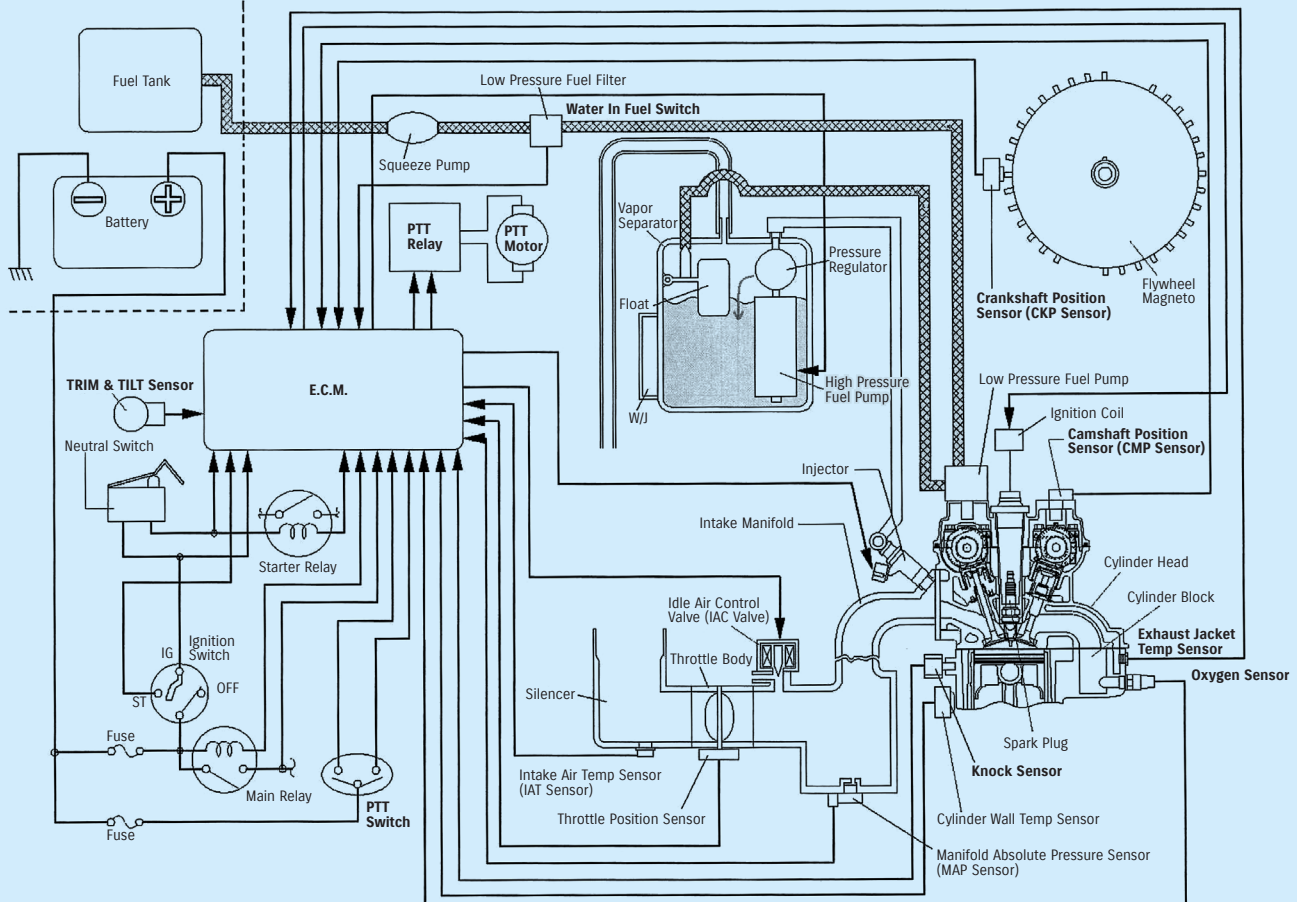

Trim and Tilt Limit System

The trim and tilt limit system is designed to help protect the boat from damage that can occur when tilting the outboard. A tilt angle sensor performs as both a tilt limit and trim sender and a step-free, continuous type tilt limiter makes installation of the outboard possible on nearly any type of boat.

Suzuki Anti Corrosion Finish

Suzuki's Anti Corrosion Finish is specially formulated to increase the durability of the engine and help protect parts of the outboard's aluminum exterior. This advanced finish is designed for maximum bonding of the finish to the outboard's aluminum surface, creating an effective treatment against corrosion.

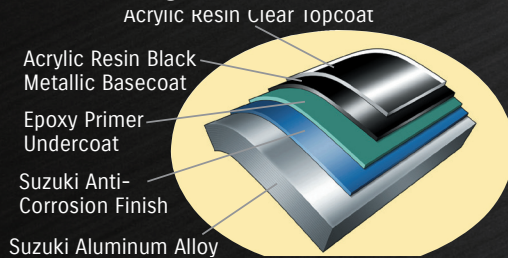

Multi Function Tiller Handle (Optional)

Available on the DF115A only, Suzuki's Multi-Function Tiller handle is ergonomically designed using computer modeling to simulate the operator's body, arm, and eye movements to optimize placement of the shift lever, switches, and indicator and provide easier, more comfortable control of the outboard. The shift lever is also ergonomically designed to provide a comfortable feel whether it's operated with the left or right hand. The power trim and tilt switch is located on the handle grip allowing simultaneous operation of the throttle and trim and the handle also incorporates a Suzuki Troll Mode System switch.



Suzuki Troll Mode System (Optional)

The Suzuki Troll Mode System is optionally available on all three outboards. This system provides finer control over engine speed at low rpms keeping the boat moving at a steady speed while trolling. When the system is engaged, engine speed is controlled with an independent control switch that adjusts engine revs in 50rpm increments over a range that spans from idle to 1,200rpm. In addition to the controls switch, which can be mounted nearly anywhere on the console, the system includes tachometer and is compatible with Suzuki's SMIS digital gauges or the dual scale analog gauges.



SUZUKI COLOR DISPLAY

The new Suzuki Color Display is a high-resolution LED network gauge that is extremely easy to read - even in bright sunlight.

It is capable of monitoring two engines simultaneously, including RPM, speed*, water pressure*, fuel level* and fuel consumption*, engine temperature, trim, engine hours and alternator voltage.

It features front-mounting points and operates on a NMEA 2000 network with one easy connection.

Benefits

- Full-color LED display is easy to read in sunlight and night-time operation
- Displays data** for one or two engines per gauge
- 3 standard preconfigured pages do not require user set-up, but they can be customized
- Software updates are made easy with micro USB
- Power and data are provided through one NMEA 2000® micro-C connector
- Fits standard 3-3/8 inch gauge cutout
- Low profile mounting points

** Data displayed depends on sensors installed in NMEA 2000® Network



DATA DISPLAY INCLUDES

- RPM
- SPEED*
- FUEL LEVEL*
- FUEL FLOW (GPH)
- FUEL USED/REMAINING
- ENGINE TEMP
- WATER PRESSURE*
- ENGINE TRIM
- ENGINE HOURS

* Requires installation of appropriate sensors.



A word from Suzuki engineers



Jun Itoh

In charge of Engine Design. Suzuki Employee for 17 years.

When we started development of the DF100A/115A/140A our goal was to retain the best characteristics of original DF140 and focus on more fuel efficiency and reliability. To achieve our goal we incorporated a number of new technologies into these outboards.

These are the first four-cylinder outboards to incorporate a knock sensor. To determine the sensor placement, we carried out a series of tests to find the proper position for mounting the sensor on the engine. Adding the knock sensor to the engine allows for finer control over engine combustion.

Some other advanced technologies featured in these outboards include an O₂ sensor, lean burn, and water-detecting fuel filter, etc., which have also been used to increase fuel efficiency and reliability in the other models.

Tomohiko Miyaki

In charge of Electronic Component Design. Suzuki Employee for 20 years.

Our trim sensor integrates the functions of both the trim sender and the tilt limit switch. We also reduced vibrations that occur in the lower trim range to provide greater operating comfort. Placement of the sensors was determined after analyzing strength of the nearby parts.

When placing sensors such as the O₂ sensor, knock sensor, etc., we looked at operating conditions within the engine room and ran simulations to test proper and reliable function. Knock sensor placement in particular, underwent repeated testing that included both actual driving and dynamometer tests to build an optimum system.

Gen Akutsu

In charge of Engine Design. Suzuki Employee for 3 years.

We developed an all-new vapor separator system that reduces overall engine weight and eases maintenance on the DF115A/140A.

By improving the cooling effect through optimum positioning of the water jacket, integrating an internal high-pressure fuel filter, and miniaturizing the high-pressure fuel pump, we succeeded in developing a lightweight and compact vapor separator. Additionally, we could eliminate the need for a fuel cooler, and through reevaluation of the cooling and fuel system layouts we were able to install a more streamlined and easier to maintain system.

Saori Nihashi

In charge of Body Design. Suzuki Employee for 7 years.

We designed an all-new engine cover that keeps with the "Progressive, Aggressive, and Strong" concept of the outboard's model change. The final design is the result of numerous sketches and clay models as well as meetings with the production department to optimize the final design.

To reduce weight we designed the cover using a thinner design that achieves a weight of the cover reduction of approximately 40%. We also place three-dimensional "S" mark on the front of the cover to offer a distinctive look.

SPECIFICATIONS

MODEL	DF140A	DF115A
ENGINE TYPE	4-Stroke DOHC 16-Valve	
FUEL DELIVERY SYSTEM	Multi Point Sequential Electronic Fuel Injection	
TRANSOM HEIGHT mm (in.)	L:508 (20), X:635 (25)	
STARTING SYSTEM	Electric	
DRY WEIGHT kg (lbs.) including battery cable, not including propeller and engine oil	L:179 (395.7), X:184 (406.8)	L:182 (401.3), X:187 (412.3)
NO. OF CYLINDERS	4	
PISTON DISPLACEMENT cm ³ (cu.in.)	2,044 (124.7)	
BORE x STROKE mm (in.)	86×88 (3.4×3.5)	
MAXIMUM OUTPUT kW(PS)/rpm	103 (140)/6000	84.6 (115)/5500
FULL THROTTLE OPERATING RANGE rpm	5600-6200	5000-6000
STEERING	Remote	Remote/Tiller
OIL PAN CAPACITY Lit (U.S. / Imp. qt.)	5.5 (5.8/4.8)	
IGNITION SYSTEM	Fully-transistorized	
ALTERNATOR	12V-40A	
ENGINE MOUNTING	Shear Mount	
TRIM METHOD	Power Trim and Tilt	
GEAR RATIO	2.59:1	
GEAR SHIFT	F-N-R	
EXHAUST	Through Prop Hub Exhaust	
DRIVE PROTECTION	Rubber Hub	
PROPELLER SIZE (in.) 3-Blade Pitch * Counter Rotation Propeller available	9" - 26"	

Specifications, appearances, equipment, colors, materials and other items of "SUZUKI" products shown on this catalogue are subject to change by manufacturers at any time without notice and they may vary depending on local conditions or requirements. Some models are not available in some territories. Each model might be discontinued without notice. Please inquire at your local dealer for details of any such changes. Actual body color might differ from the colors in this brochure.

* Boats and motors come in a large variety of combinations. See your authorized dealer for correct prop. selection to meet recommended RPM range at W.O.T. Please read your owner's manual carefully. Remember, boating and alcohol or other drugs don't mix. Always wear a personal flotation device when boating. Please operate your outboard safely and responsibly. Suzuki encourages you to operate your boat safely and with respect for the marine environment.

