

The logo features the name 'McFARLANE' in a large, bold, sans-serif font. Below it, 'MFG. CO. INC.' is written in a smaller font. To the right of the company name, 'Sauk City, Wisconsin' is printed. The entire logo is set against a black background with white text.

**McFARLANE**  
MFG. CO.  
INC. Sauk City, Wisconsin

MANUFACTURERS OF QUALITY AGRICULTURAL EQUIPMENT SINCE 1936

OPERATOR'S MANUAL  
AND  
PARTS LISTING  
FOR THE

**STM Mounted Harrow**

With FH 8-Bar Section

VERSION: 3-08AJF

TO THE OWNER AND OPERATORS

Before assembling or operating this unit, READ THIS MANUAL THOROUGHLY. To obtain the best performance of the unit, familiarize yourself with each component and adjustment. Store this manual where it can be readily available for future reference. In the event that the harrow or any part of the unit should be sold, be sure that the new owner receives a copy of this manual for their reference.

1330 DALLAS STREET, P.O. BOX 100  
SAUK CITY, WISCONSIN 53583  
PHONE: (608) 643-3321  
TOLL FREE: (800) 627-8569 FAX: (608) 643-3976

## TABLE OF CONTENTS

INTRODUCTION .....	3
LIMITED WARRANTY .....	3
SAFETY .....	4
CONTACT INFORMATION.....	5
SAFETY SIGN CARE .....	6
BEFORE OPERATION.....	7
DURING OPERATION .....	7
FOLLOWING OPERATION .....	8
PERFORMING MAINTENANCE .....	8
MAINTENANCE AND SERVICE SCHEDULE .....	8
OPERATING SUGGESTIONS.....	9
ASSEMBLY SUGGESTIONS.....	9
ASSEMBLY INSTRUCTIONS .....	10 – 13
FINAL ADJUSTMENTS .....	14
BOLT TORQUE SPECIFICATIONS .....	APPENDIX A
PARTS DIAGRAMS AND LISTS .....	APPENDIX B
LAYOUT DIAGRAMS.....	APPENDIX C

## **INTRODUCTION**

Thank you for purchasing your new McFarlane STM mounted harrow. We know that you will get many years of dependable service from this modernly designed unit.

You may have had a particular application in mind when you purchased this unit. There are actually many uses for the McFarlane harrow including incorporation of herbicides and pesticides, leveling and smoothing tilled soil, and covering of broadcast seeds. Contact your dealer if you would like more information or have questions concerning these or other applications.

## **LIMITED WARRANTY**

### **FULL ONE - YEAR WARRANTY OF**

**STM Series  
8 Bar FH**

If within one year from the date of purchase, this harrow mount and/or its accompanying harrow sections fail due to defect in material or workmanship, McFarlane Mfg. Co., Inc. will repair it, free of charge.

Warranty service is available by simply contacting the nearest McFarlane dealership throughout the United States or Canada.

This warranty applies only while this product is used in the United States or Canada.

This warranty gives you specific legal rights, and you may have other rights which vary from state to state.

McFarlane Mfg. Co., Inc., Sauk City, Wisconsin 53583

## **SAFETY**

TAKE NOTE! THIS SAFETY ALERT SYMBOL FOUND THROUGHOUT THIS MANUAL IS USED TO CALL ATTENTION TO INSTRUCTIONS INVOLVING YOUR PERSONAL SAFETY AND THE SAFETY OF OTHERS. FAILURE TO FOLLOW THESE INSTRUCTIONS CAN RESULT IN INJURY OR DEATH.



THIS SYMBOL MEANS

- **ATTENTION!**
- **BECOME ALERT!**
- **YOUR SAFETY IS INVOLVED!**

### **SIGNAL WORDS:**

Note the use of the signal words DANGER, WARNING, and CAUTION with the safety messages. The appropriate signal word for each has been selected using the following guidelines:

**DANGER:** Indicates an imminently hazardous situation that, if not avoided, will result in death or serious injury.

**WARNING:** Indicates a potentially hazardous situation that, if not avoided, could result in death or serious injury.

**CAUTION:** Indicates a potentially hazardous situation that, if not avoided, may result in minor or moderate injury.

## CONTACT INFORMATION

If you have questions not answered in this manual, require additional copies, or the manual is damaged, please contact your local dealer or:

McFarlane Mfg. Co., Inc.  
1330 Dallas Street  
P.O. Box 100  
Sauk City, WI 53583

PHONE: (608) 643-3321  
TOLL FREE: (800) 627-8569  
FAX: (608) 643-3976



## SAFETY FIRST!



### Equipment Safety Guidelines

Safety of the operator is one of the main concerns in designing and developing a new piece of equipment. Designers and manufacturers build in as many safety features as possible. However, every year many accidents occur which could have been avoided by a few seconds of thought and a more careful approach to handling equipment. You, the operator, can avoid many accidents by observing the following precautions. To avoid personal injury, study the following precautions and insist that those working with you, or for you, follow them.

Replace any CAUTION, WARNING, DANGER, or instruction safety decal that is not readable or missing.

Do not attempt to operate this equipment under the influence of drugs or alcohol.

Review the safety instructions with all users annually.

This equipment is dangerous to children and persons unfamiliar with its operation. The operator should be a responsible adult familiar with farm machinery and trained in this equipment's operations. **Do not allow persons to operate or assemble this unit until they have read this manual and have developed a thorough understanding of the safety precautions and of how it works.**

To prevent injury, use a tractor equipped with a Roll Over Protective System (ROPS). Do not paint over, remove, or deface any safety signs or warning decals on your equipment. Observe all safety signs and practice the instructions on them.

Never exceed the limits of the harrows. If their ability to do a job, or to do so safely, is in question - **DO NOT TRY IT.**



### Safety Sign Care

- Keep safety signs clean and legible at all times.
- Replace safety signs that are missing or have become illegible.
- Replacement parts that display a safety sign should display the same sign.
- Safety signs are available from your Distributor, Dealer Parts Department, or the factory.

How to Install Safety Signs:

- Be sure that the installation area is clean and dry.
- Decide on the exact position before you remove the backing paper.



### **Remember:**

**Your best assurance against accidents is a careful and responsible operator. If there is any portion of this manual or function you do not understand, contact your local authorized dealer or the manufacturer.**



### **Before Operation:**

- Carefully study and understand this manual.
- Do not wear loose fitting clothing which may catch in moving parts.
- Always wear protective clothing and substantial shoes.
- It is recommended that suitable protective hearing and (eye protection) sight protectors be worn.
- Give the unit a visual inspection for any loose bolts, worn parts, or cracked welds, and make necessary repairs. Follow the maintenance safety instructions included in this manual.
- Be sure that there are no tools lying on the unit.
- Make sure that the area is clear of children, animals, and other obstacles before using.
- Don't hurry the learning process or take the unit for granted. Ease into it and become familiar with your new equipment. Practice operation of your new unit. Completely familiarize yourself and other operators with its operation before using.



### **During Operation:**

- **NO PASSENGERS ALLOWED** - Do not carry passengers anywhere on, or in, the tractor or equipment, except as required for operation.
- Keep hands and clothing clear of moving parts.
- Do not clean, lubricate, or adjust your equipment while it is moving.
- When altering operation, even periodically, set the tractor or towing vehicle brakes, shut off the engine, and **remove the ignition key**.
- Periodically clear the equipment of brush, twigs, or other materials to prevent buildup of dry combustible materials.
- Avoid overhead wires or other obstacles. Contact with overhead lines could cause serious injury or death.
- Keep all bystanders, pets, and livestock clear of the work area, particularly when raising or lowering harrow sections.
- As a precaution, always recheck the hardware on equipment periodically. Correct all problems. Follow the maintenance safety procedures.



### **Following Operation:**

- Store the unit in an area away from human activity on a hard level surface.
- Do not park equipment where it will be exposed to livestock for long periods of time. Damage and livestock injury could result.
- Do not permit children to play on or around the stored unit.



### **Performing Maintenance:**

- Good maintenance is your responsibility. Poor maintenance is an invitation to trouble.
- Before working on this machine, stop the tractor or towing vehicle, set the brakes, lower into field position, shut off the engine and **remove the ignition keys**.
- **Always** use safety support and block the wheels. When performing maintenance, never use a jack to support the machine. Assist the jack with blocks or other adequate support.
- Use extreme caution when making adjustments.
- After servicing, be sure all tools, parts, and service equipment are removed.
- Never replace hex bolts with less than grade five bolts unless otherwise specified.
- Where replacement parts are necessary for periodic maintenance and servicing, genuine factory replacement parts must be used to restore your equipment to original specifications. The manufacturer will not claim responsibility for damages as a result of the use of unapproved parts and/or accessories.
- If equipment has been altered in any way from original design, the manufacturer does not accept any liability for injury or warranty.

## **MAINTENANCE AND SERVICE SCHEDULE**

- Prior to each use, check for loose bolts and replace lost or worn parts.
- Remove dirt and debris from the harrow sections before storage.
- Parts diagrams and listings for service and repair references may be found in appendix B.



## **OPERATING SUGGESTIONS**

There are some important points to remember in order to obtain the best possible results from your McFarlane harrow.

- To maximize the harrow's performance, it should be towed at speeds ranging from six to nine (6 - 9) mph. This keeps the field debris moving through the harrow sections and avoids clogging. The best results will be obtained after the paint has been scoured from the teeth.
- Adjust the pull tube insert height so that when the harrows are being pulled in the field position the pull chains pull the sections at a slight upward angle.
- Adjust the lift chain length so that when the harrows are in the transport position the harrow teeth don't drag on the ground. (Approximately 2 to 3 links loose when in the field position.)

## **ASSEMBLY SUGGESTIONS**

- You will find the machine is easier to assemble if the set-up instructions are followed in the order given in the manual.
- Whenever the terms "left" and "right" are used, it should be understood to mean when standing behind and facing the unit. This is also known as the "driver's left" and the "driver's right."
- The term "field position" refers to the position the harrows are in when the unit is being used in the field - that is, with the harrow sections down.
- The term "transport position" refers to the position the harrows would be in when the unit is being transported from place to place - that is, with the harrows up.
- When assembling this unit, make sure that the parts are securely held before proceeding to the next step.
- Bolt torque specifications are given in appendix A.
- Layout diagrams for each unit may be found in appendix C. Mark the page with the diagram that refers to your unit, it will be referred to periodically throughout the manual.

## STEP - BY - STEP ASSEMBLY INSTRUCTIONS

### Determine the Layout

Spend some time on this first step to make sure that you have it correct, it will save time later on.

Because of the placement of the Pull Arms, what you need to determine is the locations on the rear tube of the main unit that the Main Arms cannot be attached. Look at the diagram in appendix C, each section of the main unit will have either one, two or three harrow sections attached to it.

1. Determine which harrow sections go where behind the main unit. Use appendix C for assistance in harrow information and identification.
2. Decide where each Main Arm should go on the rear tube of the main unit. The exact spacing of the Main Arms isn't important, but try to keep them as evenly spaced as possible across the main unit. (Remember, Main Arms can't go where the pull arms go.) The number of main arms required is noted in the layout for the specified harrow coverage.
3. Use the dimensions in appendix C to determine where each Pull Arm should go on the Cross Tubes.

### Attach the Main Arms

Using the locations that you determined for the Main Arms in the previous step, attach the Main Arms to the rear tool bar of the cultivator. Use the 5/8 X 6 bolts, lock washers and hex nuts. Do Not tighten the bolts yet.

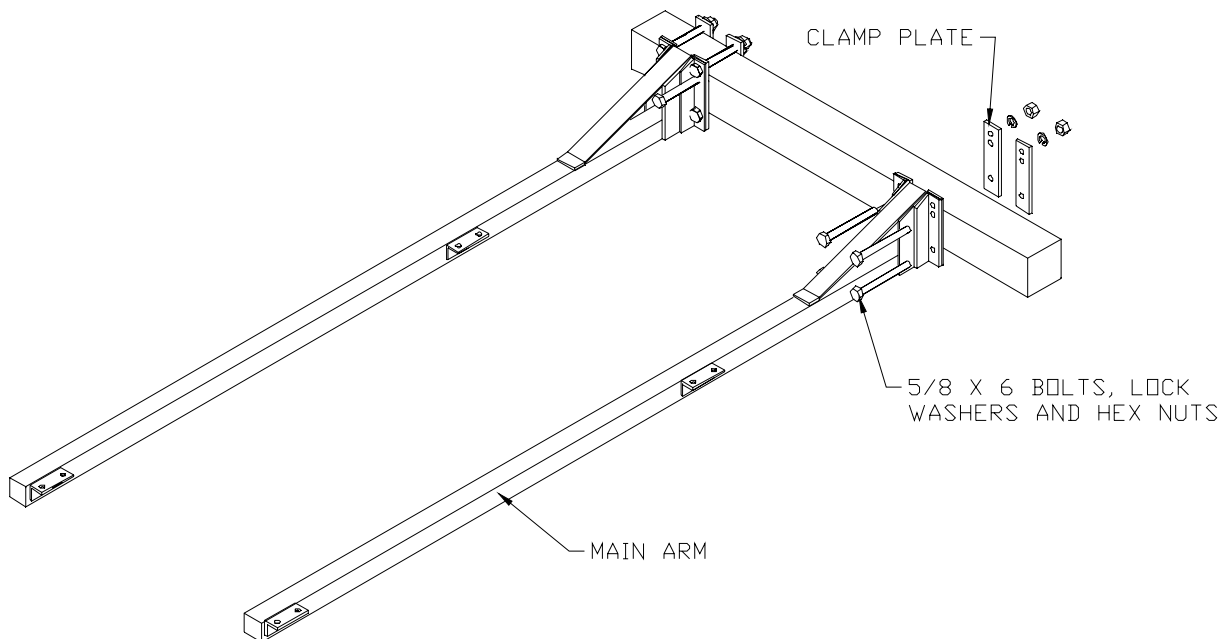

**Figure 1**

## Attach the Cross Tubes

Position the Cross Tubes across the tops of the Main Arms with equal distance out both sides Use the 7/16 x 2 x 3 U-bolts, lock washers and lock nuts to bolt the cross tubes in place. Don't tighten the bolts yet.

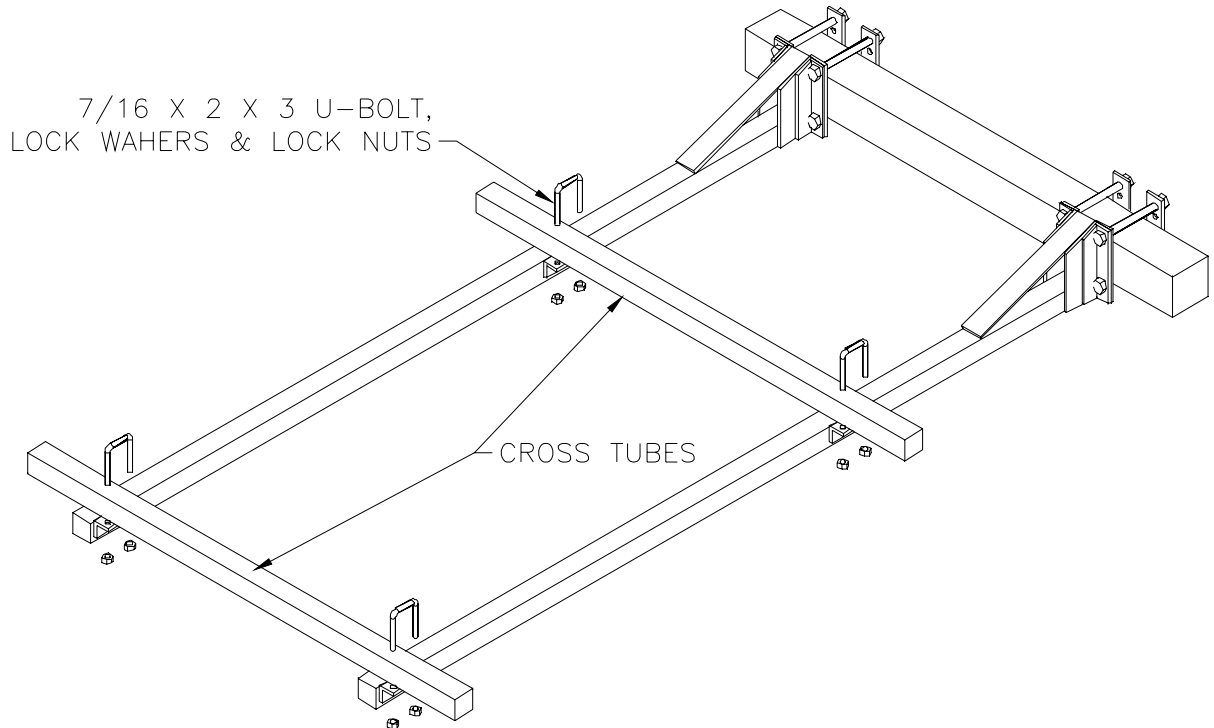
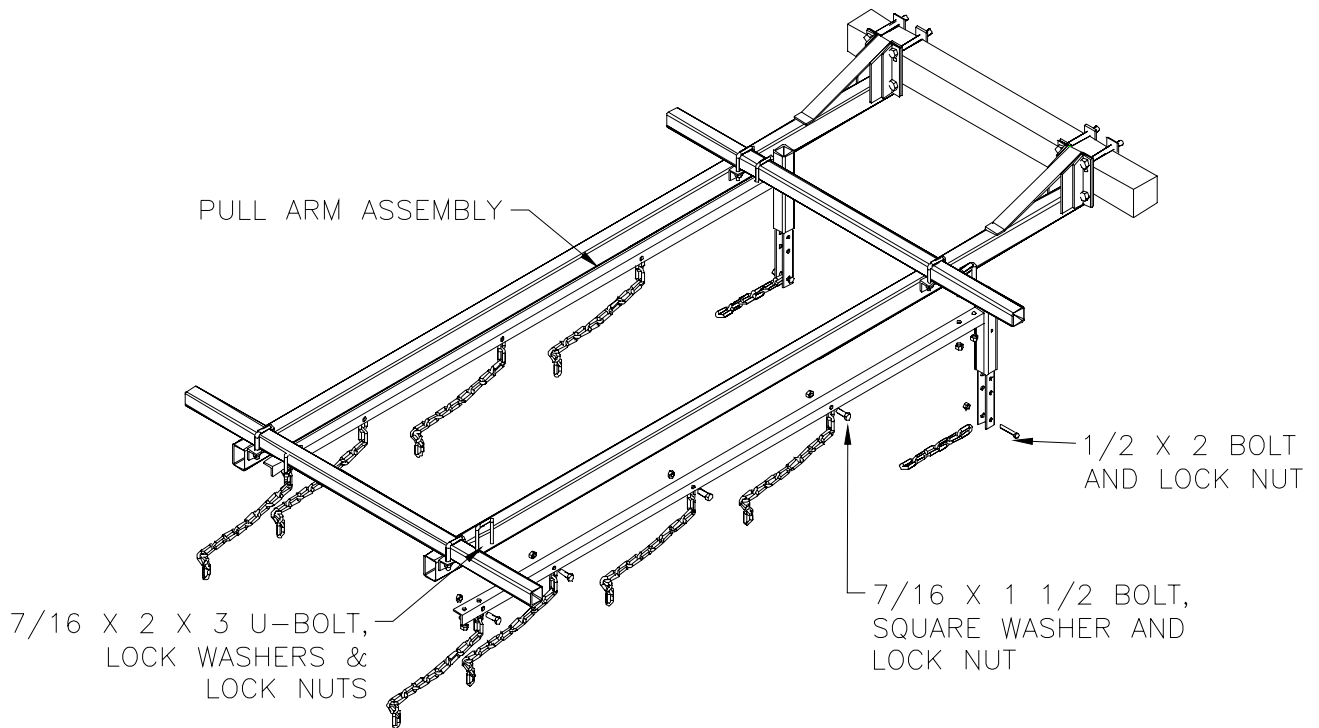

Figure 2

## Attach the Pull Arms

1. Bolt the Pull Arms to the Cross Tubes at each of the locations that you determined in the first step. Use the 7/16 x 2 x 3 U-bolts and lock nuts
2. Bolt the 6-Link Pull Chains to the front of the Pull Arm using  $\frac{1}{2}$  x 2 bolts and lock nuts.
3. Bolt the 14-Link Lift Chains to the Pull Arm using 7/16 x 1  $\frac{1}{2}$  bolt, square washer and lock nut.

Note: It may be necessary to move the Main Arms slightly in order to get the Pull Arms in the proper locations.

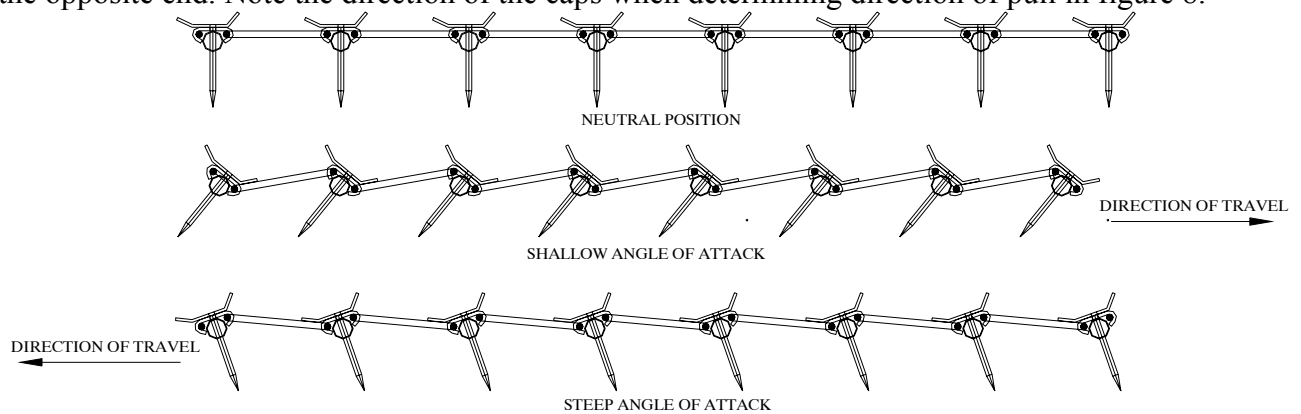

**Figure 3**

Before moving on to the next step, tighten up all nuts and bolts that have been installed up to this point.

### **Angle of Attack**

Before placing the harrows into their appropriate places, determine the angle of attack desired. The angle of attack can be changed by simply reversing the harrow sections and pull them from the opposite end. Note the direction of the caps when determining direction of pull in figure 8.



### **Harrow Identification**

Harrow section identification is quite simple, the first two letters (FH) indicates the harrow type. The next number (500, 600, etc.) tells the number of teeth per bar (500 = 5 teeth per bar).

### **Attach the Harrow Sections**

1. Referring to the layout diagram in appendix C, position the harrow sections under the main arms and cross tubes as shown. Keep in mind the harrow size and the angle of attack desired.
2. Bolt the harrow sections to the pull and lift chains using the fasteners identified in Figure 4.

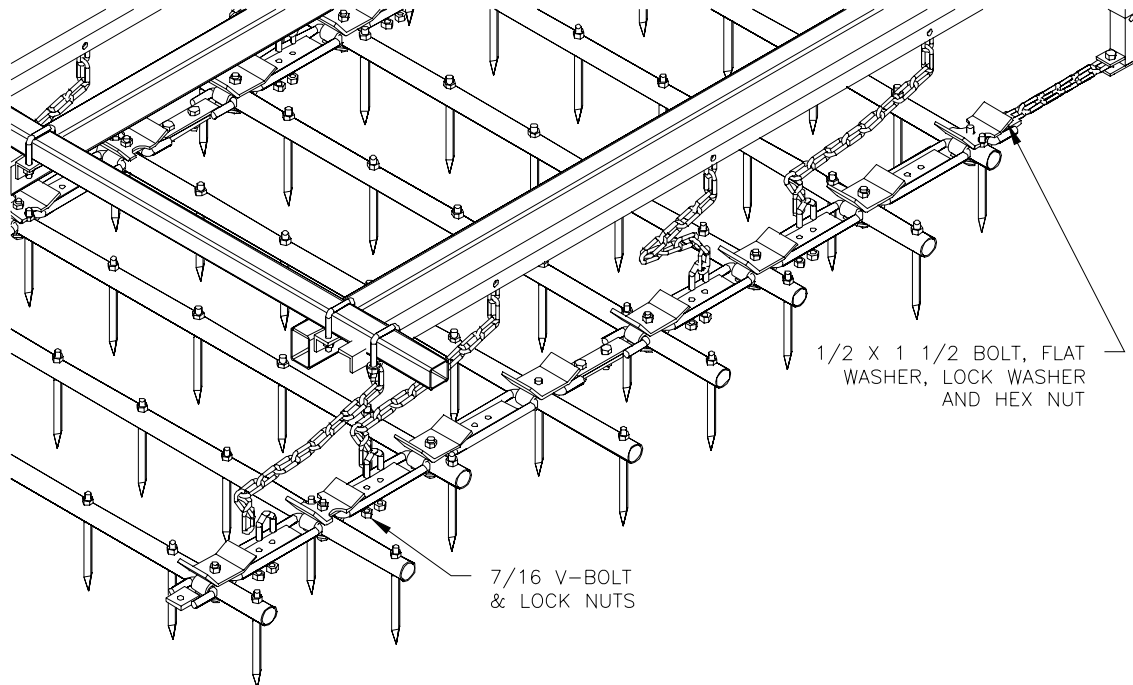

**Figure 4**

### **Final Adjustments**

1. Lower the unit into the field position.
2. Pull the completed unit ahead a few feet to check that everything is properly assembled and that nothing is binding or misaligned.
3. Check to make sure that all bolts and fasteners are tight.
4. Adjust the pull tube heights so that when the harrows are being pulled in the field position the pull chains pull the harrow sections at a slight upward angle.
5. Adjust the lift chains so that when the harrows are in the transport position the harrow teeth don't drag on the ground.
6. After the first few hours of operation, check all fasteners and tighten if necessary.

This completes the assembly of your STM mounted harrow. Before using the unit, double check that all components have been assembled properly. If there are any questions regarding any of the assembly steps, contact your local dealer for an explanation. Do not operate this or any equipment unless you are sure that all components operate as they were designed to operate.

## BOLT TORQUE SPECIFICATIONS

Coarse Thread Series		
Nut Size and Threads per Inch	Nut Tightening Torque (lb.ft.)	
Grade C Nuts		
	Max.	Min.
1/4 - 20	14.7	10
5/16 - 18	22.3	15.2
3/8 - 16	39	28
7/16 - 14	60	44
1/2 - 13	88	63
9/16 - 12	134	98
5/8 - 11	172	127
3/4 - 10	295	218
7/8 - 9	440	317
1 - 8	651	506

Fine Thread Series		
Nut Size and Threads per Inch	Nut Tightening Torque (lb.ft.)	
Grade C Nuts		
	Max.	Min.
1/4 - 28	14.7	10
5/16 - 24	23.4	18.4
3/8 - 24	41	30
7/16 - 20	60	44
1/2 - 20	98	70
9/16 - 18	134	98
5/8 - 18	176	127
3/4 - 16	295	218
7/8 - 14	440	317
1 - 14	703	610

## 8-BAR STM PARTS LIST FOR STRAIGHT TOOL BAR MOUNTING

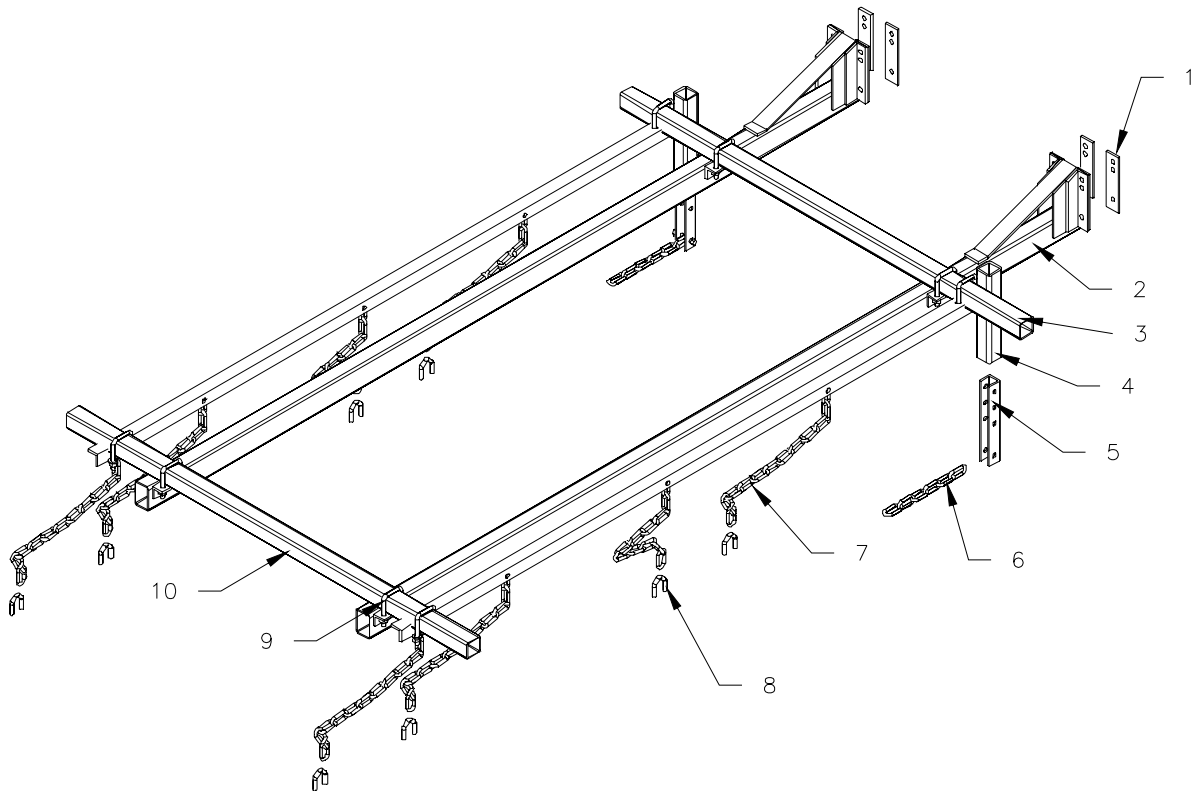

Always order by Part Number - *Not* by Key Number

KEY	PART #	DESCRIPTION
1	STM-3001	MAIN ARM CLAMP PLATE
2	STM-3510	MAIN ARM
3	****	FRONT CROSS TUBE
4	STM-2505	PULL ARM
5	STM-2040	INSERT CHANNEL
6	CH-0706	6-LINK PULL CHAIN
7	CH-0714	14 LINK LIFT CHAIN
8	BV-7611	7/16 V-BOLT
9	BU-7623	7/16 X 2 X 3 U-BOLT
10	****	REAR CROSS TUBE

\*\*\*\*

Please specify length when ordering these parts.

**McFarlane Manufacturing reserves the right to change specifications of design at any time without obligation to modify previous products.**

**FH-8-BAR HARROW SECTIONS**  
INCLUDES FH-500-8, FH-600-8, FH-700-8, FH-800-8, AND FH-900-8  
**PARTS DIAGRAM**

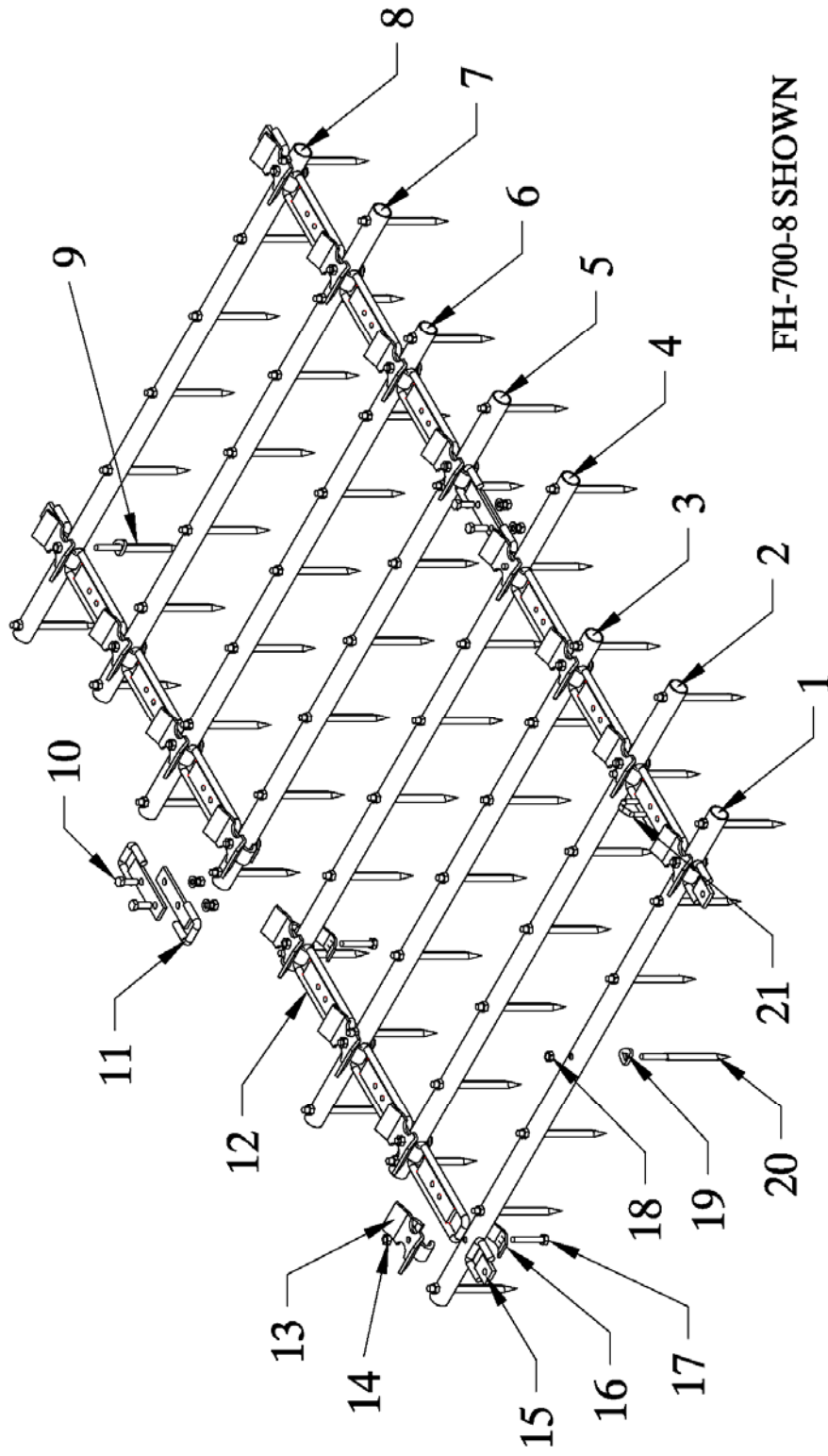

FH-700-8 SHOWN



**FH-8-BAR HARROW SECTIONS  
PARTS LIST**

ITEM #	PART #	DESCRIPTION
1	FH-801	#1 HARROW BAR (FH-500-8)
1	FH-805	#1 HARROW BAR (FH-600-8)
1	FH-809	#1 HARROW BAR (FH-700-8)
1	FH-813	#1 HARROW BAR (FH-800-8)
1	FH-817	#1 HARROW BAR (FH-900-8)
2	FH-802	#2 HARROW BAR (FH-500-8)
2	FH-806	#2 HARROW BAR (FH-600-8)
2	FH-810	#2 HARROW BAR (FH-700-8)
2	FH-814	#2 HARROW BAR (FH-800-8)
2	FH-818	#2 HARROW BAR (FH-900-8)
3	FH-802	#3 HARROW BAR (FH-500-8)
3	FH-806	#3 HARROW BAR (FH-600-8)
3	FH-810	#3 HARROW BAR (FH-700-8)
3	FH-814	#3 HARROW BAR (FH-800-8)
3	FH-818	#3 HARROW BAR (FH-900-8)
4	FH-804	#4 HARROW BAR (FH-500-8)
4	FH-808	#4 HARROW BAR (FH-600-8)
4	FH-812	#4 HARROW BAR (FH-700-8)
4	FH-816	#4 HARROW BAR (FH-800-8)
4	FH-820	#4 HARROW BAR (FH-900-8)
5	FH-803	#5 HARROW BAR (FH-500-8)
5	FH-807	#5 HARROW BAR (FH-600-8)
5	FH-811	#5 HARROW BAR (FH-700-8)
5	FH-815	#5 HARROW BAR (FH-800-8)
5	FH-819	#5 HARROW BAR (FH-900-8)
6	FH-803	#6 HARROW BAR (FH-500-8)
6	FH-807	#6 HARROW BAR (FH-600-8)
6	FH-811	#6 HARROW BAR (FH-700-8)
6	FH-815	#6 HARROW BAR (FH-800-8)
6	FH-819	#6 HARROW BAR (FH-900-8)
7	FH-801	#7 HARROW BAR (FH-500-8)
7	FH-805	#7 HARROW BAR (FH-600-8)
7	FH-809	#7 HARROW BAR (FH-700-8)
7	FH-813	#7 HARROW BAR (FH-800-8)
7	FH-817	#7 HARROW BAR (FH-900-8)
8	FH-804	#8 HARROW BAR (FH-500-8)
8	FH-808	#8 HARROW BAR (FH-600-8)
8	FH-812	#8 HARROW BAR (FH-700-8)
8	FH-816	#8 HARROW BAR (FH-800-8)
8	FH-820	#8 HARROW BAR (FH-900-8)
9	E-611	1/2" x 3" SHANK SPIKE TOOTH w/WASHER
**	E-621	1/2" x 3" SHANK SPIKE TOOTH ONLY
10	**	1/2" x 1 1/2" BOLT, LOCK WASHER AND NUT

11	FH-124	8-BAR CONNECTOR FLAT
12	FH-135	CONNECTOR LINK (STM)
13	FH-127	NOTCHED LINK CAP
14	**	1/2" LOCK NUT
15	FH-122	PULL FLAT
16	FH-019	CAP CLIP
17	**	1/2" x 3" BOLT
18	**	1/2" FLANGED LOCK NUT
19	E-630	SPIKE TOOTH WASHER
20	E-620	1/2" x 2 1/2" SHANK SPIKE TOOTH ONLY
**	E-610	1/2" x 2 1/2" SHANK SPIKE TOOTH w/WASHER
21	HDL-5100	DUAL SECTION CONNECTOR FLAT (16 BAR ONLY)
22	**	7/16" V-BOLT (16 BAR ONLY)
23	**	1/2" x 2" BOLT, LOCK WASHER AND NUT (16 BAR ONLY)
**	HDL-5101	DUAL SECTION CONNECTOR ASSEMBLY (16 BAR ONLY)

The #1 bar is the bar with an equal amount of tube to the right and left of the pull flats. The #8 bar is the bar that is staggered off to one side.

When pulling the harrow section from the #1 bar, the teeth will be in the least aggressive setting. When pulling from the #8 bar the teeth will be in the most aggressive setting.

3/20/08

3'9" — 8'3": 2 MAIN ARMS  
 9'0" — 13'7": 3 MAIN ARMS  
 14'4" — 16'7": 4 MAIN ARMS

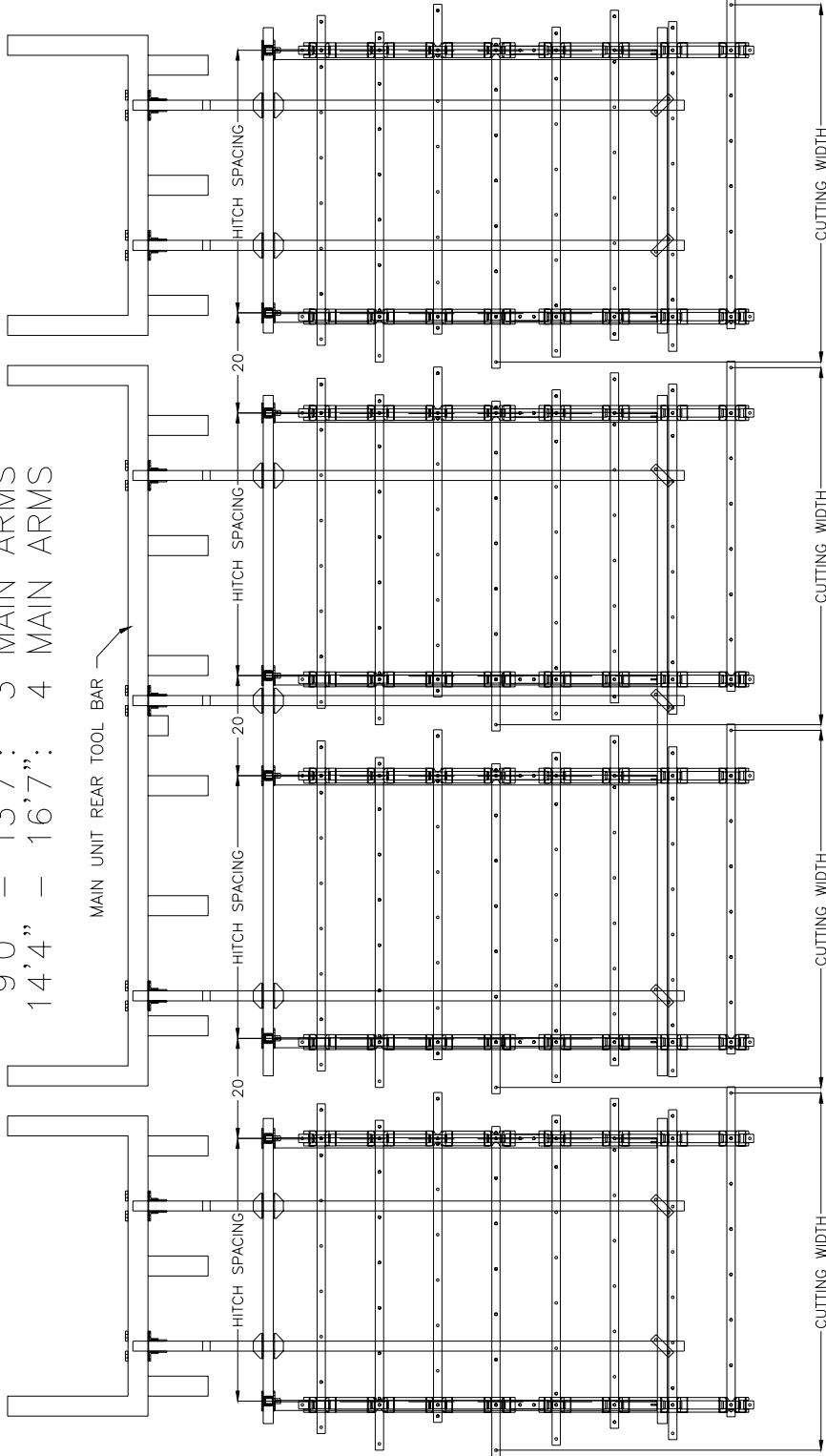

HARROW MODEL	BAR LENGTH	CUTTING WIDTH	HITCH SPACING
FH-500	38 3/4"	3' 9"	25 3/8"
FH-600	47 7/8"	4' 5"	34 1/2"
FH-700	56 7/8"	5' 3"	43 1/2"
FH-800	66"	6' 0"	52 1/2"
FH-900	75"	6' 9"	61 5/8"