

WEAVERLINE

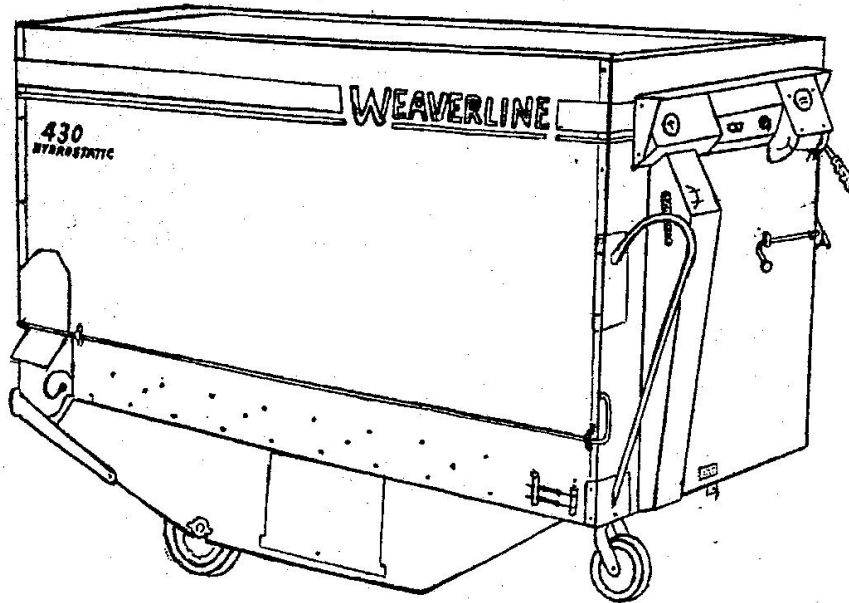

Operator's Manual Series 4 Feed Cart

Models 420, 424, 430, & 436



CAUTION: Drive at a speed slow enough to insure safety and complete control at all times.



CAUTION: Know the controls and how to stop quickly. **READ THIS OPERATOR'S MANUAL.**

Weaverline Corporation • Churchtown, Pa. 17555



WARNING

- Always remove key when servicing or when not in use.
- Make certain everyone is clear of cart before engaging either the feeding or propelling drive.
- Operate cart at a safe speed.
- Shut off motor when loading or stopping feeding even for short time.
- Keep shields in place.
- Always shield eyes when working near batteries.



This Safety Alert Symbol Indicates Important Safety Messages In This Manual. When You See This Symbol Carefully Read The Message That Follows and Be Alert To The Possibility Of Personal Injury Or Death

FAILURE TO HEED MAY RESULT IN PERSONAL INJURY

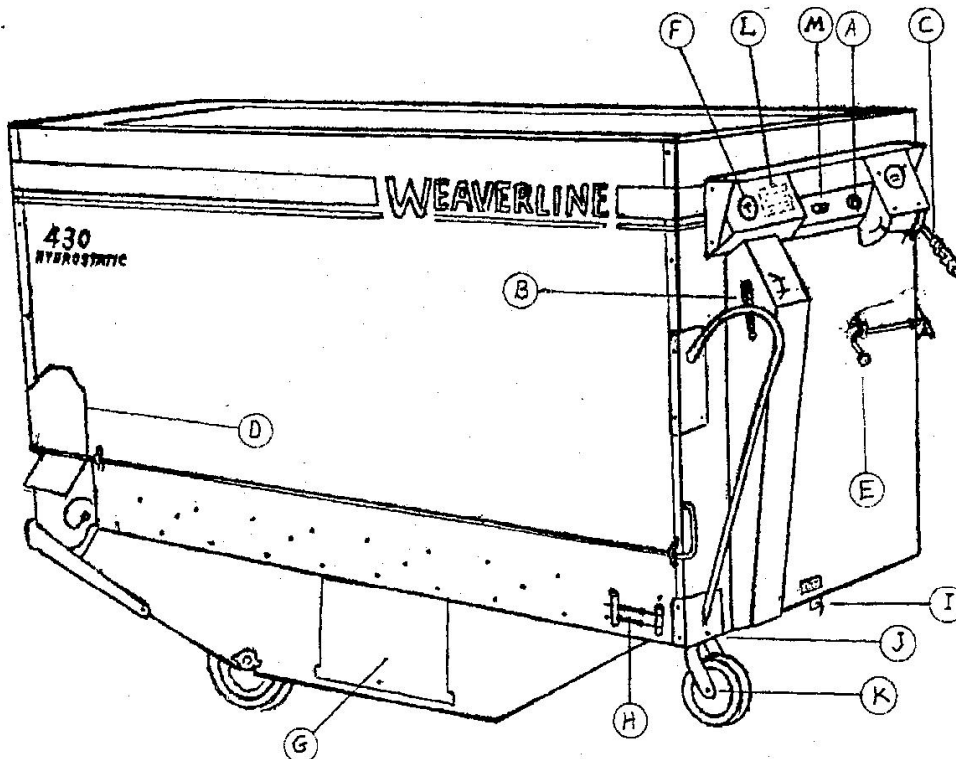

OPERATING INSTRUCTIONS



Read this entire section before operating cart.



Make certain everyone is clear of cart.

Starting the Cart

Turning the key switch (A) on will start the motor.



Remember! If you have any problem, turn key off to stop everything before correcting problem.

Self-Propelled Drive

With the key switch (A) on, moving the lever (B) labeled "Forward and Reverse" will move the cart in the direction indicated. As the lever is advanced, speed of the cart will increase. For reverse, control lever is moved rearward.



Always look behind you before backing.

Loading the Cart

Before loading feed into the cart, move the right lever (C) to the top of 8 positions labeled "Load and Start." Close discharge door (D) and cart may be loaded with feed.

Feeding With the Cart

To begin feeding, open the discharge door (D) and raise lever (E) "Feeder Clutch" at center of controls. Only the 2 lower augers will begin feeding. Move right lever (C) from "Load and Start" to "Beaters;" all feed at front of cart will begin feeding. Move right lever (C) to the feed rate #1, and increase as desired to #2 or #3 in heavy material, or up to #6 in light feeds, and to empty the cart completely out.

CHARGING THE BATTERIES

When to Charge

After each feeding, observe voltmeter (F) while key is turned on with only the motor running. In normal use, recharge only if needle is in red "Recharge" area. See "charging instruction" decal (L) on cart. *With good batteries, cart should operate for up to 30 or more cart loads per charge.*

Note: When new batteries are used for the first time, they may only have power for 20 loads. With the second charge, they may be good for 25 loads, and on the third charge they should be good for 30 or more loads.

For long battery life, it is *important* to get as many loads as possible per charge.

Charging With MAC TR-24 Charger

Connect charger plug into receptacle (M) on cart. Turn charger knob to "ON" position. Meter on charger should indicate rate of charge. When batteries are full, charger will automatically shut off. (Elapsed time indicator will normally show that charger was on for 7 hours.) Turn charger knob off, disconnect charger plug from cart, and cart is ready for use.

Charging With MAC V-24 Charger

Connect charger plug into receptacle (M) on cart. The charger will automatically turn on. The meter shows rate of charge. Status indicator lights on charger show battery condition. When batteries are full, the microprocessor circuit automatically shuts off charger. Disconnect charger plug from cart, and cart is ready for use.

BATTERY CARE AND SERVICE



WARNING

BATTERIES EMIT HYDROGEN GAS WHICH CAN EXPLODE

BATTERIES CONTAIN SULFURIC ACID WHICH IS POISONOUS AND CORROSIVE

BATTERY TERMINAL CONTACT WITH THE FRAME OR BARE WIRE CAN CAUSE SPARKS

SPARK OR EXPLOSION FROM BATTERIES MAY CAUSE SEVERE PERSONAL INJURY OR DEATH

BEFORE OPENING BATTERY DRAWER

TURN KEY SWITCH OFF AND REMOVE KEY

SHIELD EYES AND FACE WHEN SERVICING BATTERIES

DO NOT SMOKE OR PERMIT SPARKS OR OPEN FLAME NEAR BATTERIES

BE SURE ALL WIRES ARE ROUTED PROPERLY AND WILL NOT CATCH ON TERMINAL POSTS

BATTERY TERMINALS MUST NOT TOUCH FRAME, KEEP DEBRIS FROM UNDER BATTERY

KEEP ALL INSULATING PROTECTIVE DEVICES IN PLACE

REPLACE DAMAGED OR WORN BATTERY CABLES IMMEDIATELY

FAILURE TO FOLLOW THESE WARNINGS MAY RESULT IN PERSONAL INJURY OR DEATH

CIRCUIT BREAKER

All carts built after early 1997 are equipped with a 120 amp circuit breaker with a manual reset lever. The circuit breaker will trip if cart is jammed and will not run until circuit breaker is reset.

Important: If augers are jammed and motor will not run, take the following steps:

1. **Safety first — turn off and remove key!**
2. Be sure to disengage feeder clutch.
3. Open side shield and turn 8" pulley backwards (counter-clockwise) to release silage overload. Remove slug if necessary.
4. Raise right hand control lever all the way up to "Load and Start" position.
5. Push battery drawer to left side of cart to gain access to circuit breaker.
6. With key switch turned off, reset the circuit breaker and the cart should be ready to go again.

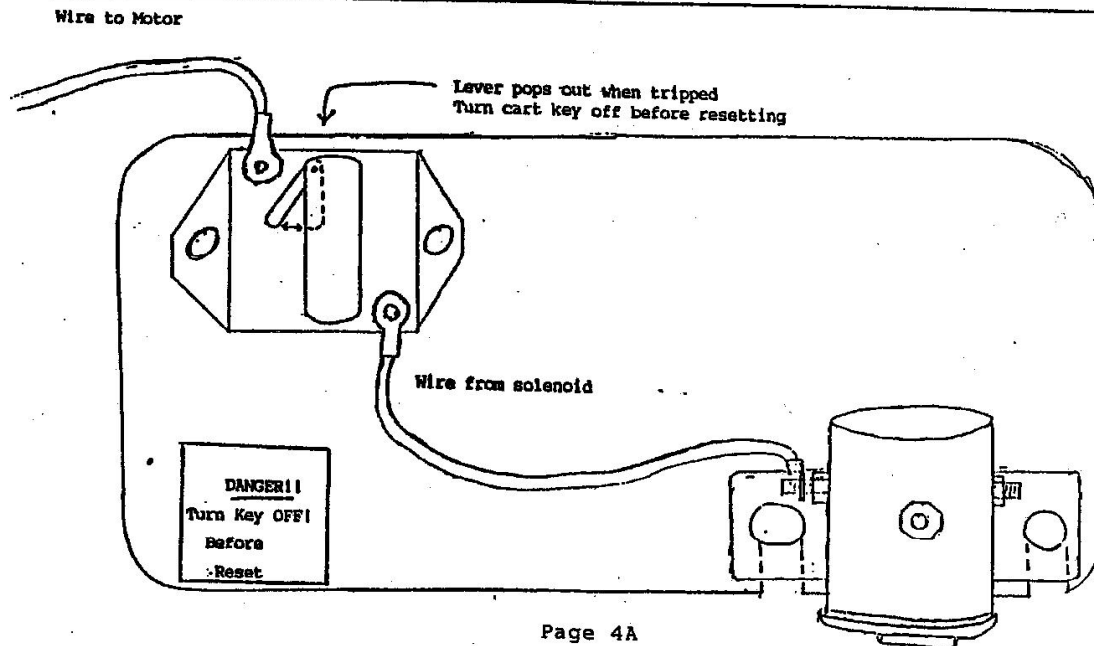

Monthly

Check water level in batteries by rolling out battery tray (G) first to the right and then to the left. Add clean water only if needed.



WARNING: Always wear eye and face protection when working around batteries. Read warning on preceding page.

Carefully inspect cable connections at batteries for corrosion. Remove and clean if needed. Replace if badly corroded. *Always* scrape top of each battery post with pocket knife for a bright clean lead surface. Also scrape the cable terminal where it contacts the battery post. Re-install and tighten securely.

LUBRICATION AND SERVICE

Monthly

Check hydrostatic oil level in clear tube inside main shield. Check when cold. If low, add only to midpoint by removing breather from top of tube. Allow no dirt to enter. Use IHC Hytran or MF Permatran 3 oil. Do *NOT* drain or attempt to change oil in hydrostatic unit.

Every 6 Month

Grease fitting on swivel of caster (J)

Grease fitting on wheel of caster (K)

A drop of oil:

1. Hinge and pivot points in controls and linkages
2. Rod end bearing on ratchet drive at top sprocket
3. Roller wheels (6) on battery tray
4. Latch on right handle

Several drops of oil:

1. On roller chains
2. At left bearings on augers. First remove any wrapped material.

Maintenance and Adjustment

Spring tension on conveyor chain, adjust to 2½" spring length.

Adjust belt guides at motor pulley (see page 6).

TROUBLE SHOOTING



Safety first—turn off and remove key!

Feeder Drive

Feeder belt slips and augers jam

1. Adjust feeder clutch adjustment for 2" spring length when engaged.
2. Replace belt if badly worn.

TROUBLE SHOOTING (continued)

Feeder drive will not stop when clutch is disengaged and continues coasting and belt grabs or feeder belt will not release in neutral

1. Adjust belt guides (with key switch turned off and feeder clutch engaged).
Clearance at motor pulley should be $\frac{1}{16}$ " on straight side and $\frac{3}{16}$ " on idler side.
2. Be sure to have proper length belt.

SP Drive Trouble Shooting

Cart wants to "creep" in neutral

Adjust clevis at front end of cable.

Cart will not drive

1. Be sure free wheel lever (I) is engaged—pushed in all the way.
2. Check hydro oil level.
3. Check if hydro unit is okay. If drive chain leaving hydro is turning, then look for missing keys, sprockets out of place, chains off sprockets, etc.

Avoid removing hydrostatic unit unnecessarily!

1. Check key in input shaft.
2. Check key in output shaft.
3. Check keys, sprockets, and chains in final drive.
4. Check low oil or air in system.
5. Check control arm movement on hydro.
6. Check that the free wheel lever is pushed in.

Extra noise and vibration with only the motor running

Coupler will be noisy unless perfectly aligned to hydro unit—vertically with shims and fore and aft by slots.

Electrical Trouble Shooting

If Charger Does Not Charge

1. Check A-C voltage to charger.
2. Check fuse on front panel of charger (or inside charger).
3. Check for good clean cable connections at batteries.
4. Have your charger checked by a dealer.

If Cart Motor Does Not Run

1. Check Circuit Breaker, See Page 4A
2. Check for good clean cable connections at batteries.
3. Check key switch and solenoid.
4. Check-motor.

If Motor Runs Slow or Motor Speed is Erratic (Up and Down in Speed)

Immediately check motor! Brushes may be worn and need replacement. If not repaired in time, motor can be ruined.

Ask your dealer about motor repair or rebuilt motor exchange.

Copyright © 1997

Weaverline Corporation ● Churchtown, Pa. 17555