

OPERATION AND PARTS MANUAL

COBRA 4200 SERIES Universal Tillage®

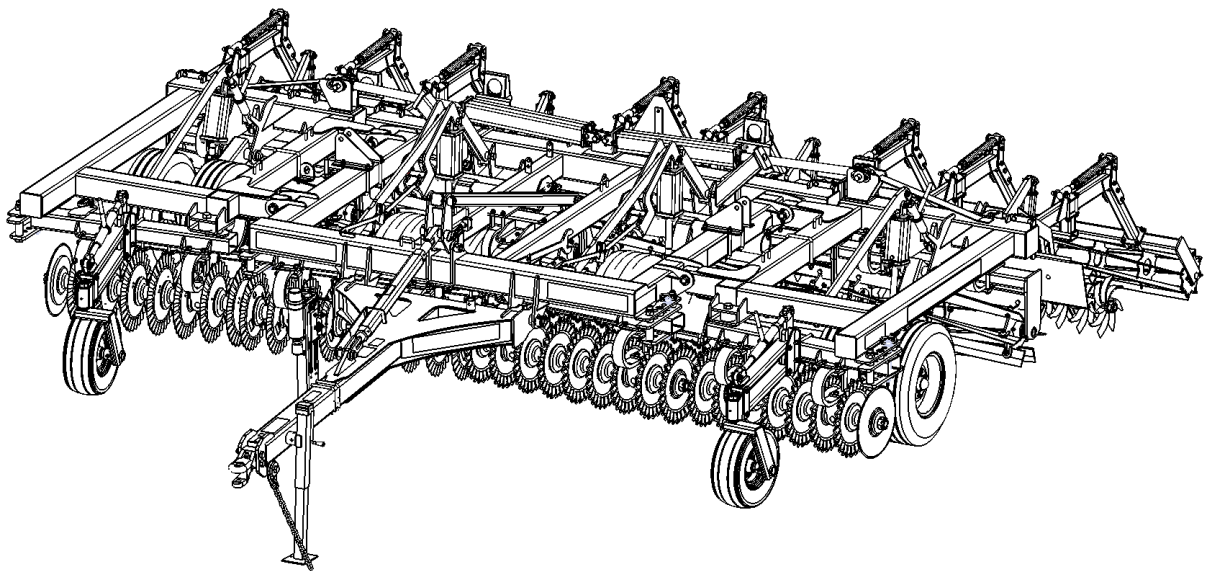

Read and understand the manual. This manual provides information and procedures to safely operate and maintain the Cobra 4200.



PART NUMBER: 15378 — Serial Number 22856 - higher

Learn more at www.mcfarlaneag.com

Table of Contents			
Introduction	3	Operation	18
Contact Information	3	Safety	18
Safety	3	Initial Setup	18
General	3	Disk Gang Adjustment	19
Safety Alert Symbols	4	Machine Leveling	20
Safety Icons Nomenclature	5	Dura-Reel Adjustment	22
General Operating Safety	6	Spur-Till Operation and Adjustment	25
Towing Safety	6	Preparing for Transport	26
Operation Safety	6	Maintenance	27
Assembly Safety	6	Safety	27
Maintenance Safety	6	Tire and Lug Torque Specifications	28
Component Nomenclature	7	Bolt Torque Chart	28
Component Locations	7	Maintenance Schedule	29
Specifications	8	Maintenance Procedures	31
Hydraulic Requirements	8	Assy/Lubrication Dura-Reel Hub	31
Horsepower Range	8	Lubrication Locations Drawing	32
Tillage Depths	8	Hydraulic Component Safety	33
Disk gang depth up to 4" (10.2 cm)	8	Tire Safety	33
Tongue Weight	8	Storage	34
Overall Weight (GVWR)	8	Safety	34
Transport Width	8	Power wash the unit prior to storage	34
Transport Height	8	Placing Into Storage (Disk Coatings)	35
Working Tillage Width (Cut Width)	8	Warranty	35
Field Capacity (acre/hr @ 6-9 mph)	8	Limited Warranty Statement	35
Towing Speed	8	Serial Number Location	35
Display of Hazard and Info Signs	9	Troubleshooting	36
Towing	11	Parts Section	37
General Safety	11	Ordering Parts	37
Safety Chain	12	Dealer Contact Information	37
Bystanders	12	Decals	37
Towing and Maximum Towing Speed	12	Parts Drawings	38
Highway and Transport Operations	12		
Pre-towing Checklist	13		
Safety	14		
Prior to Connecting Unit	14		
Tow Chain	14		
Connecting to the Tractor	15		

Introduction

The 4200 Series Cobra from McFarlane Mfg. is our latest development in Universal Tillage® and can satisfy all of the demands of today's farming practices, especially BT corn and corn on corn cropping. This tool features wavy, serrated Cobra disk blades, loosens the top one to four inches of the soil yet leaves the seedbed firm. This ensures accurate seed depth at planting, resulting in even emergence and better yields. Smoothing uneven ground and removing small weeds are done quickly at the 7-9mph operating speeds.

The Cobra is available in a 12' and 14' wide rigid frame, as well as 20', 25', 30' 35' and 45' folding frames. The horsepower required to pull the Cobra is approximately 8-9 hp per foot of width. Therefore the 12' Cobra requires as little as 100 hp while the 45' requires up to 405 hp.

Contact Information

If you have questions not answered in this manual, require additional copies, or the manual is damaged, please contact your local dealer or:

McFarlane Mfg. Co., Inc.
1330 Dallas Street
P.O. Box 100
Sauk City, WI 53583

Phone: (608) 643-3322

Toll Free: (888) 627-8569

Fax: (608) 643-3976

E-mail: info@mcfarlanemfg.com

Web: www.mcfarlaneag.com

Safety

General

Safety of the operator and bystanders is one of the main concerns in designing and developing a new piece of equipment. Designers and manufacturers build in as many safety features as possible. However, every year many accidents occur which could have been avoided by a few seconds of thought and a more careful approach to handling the equipment.

Most work related accidents are caused by failure to observe basic safety rules or precautions. An accident can often be avoided by recognizing potentially hazardous situations before an accident occurs. As you assemble, operate, tow, or maintain the Cobra (unit), you must be alert to potential hazards. You should also have the necessary training, skills, and tools to perform any assembly or maintenance procedures.

Improper operation and maintenance of this unit could result in a dangerous situation that could cause injury or death.

WARNING



Do not use or tow the unit until you read and understand the information contained in this manual.



Safety precautions and warnings are provided in this manual and on the unit. If these hazard warnings are not heeded, bodily injury or death could occur to you or to other persons.

McFarlane cannot anticipate every possible circumstance that might involve a potential hazard. The warnings in this manual and on the product are, therefore, not all-inclusive. If a method of operation not specifically recommended by us is used, you must satisfy yourself that it is safe for you and for others. You should also ensure that the unit will not be damaged or be made unsafe by the methods that you choose.

The information, specifications, and illustrations in this manual are based on the information that was available at the time this material was written and can change at any time.

Safety Alert Symbols



This is the safety alert symbol. It is used to alert you to potential personal injury hazards. Obey all safety messages that follow this symbol to avoid possible injury or death.

This manual contains DANGERS, SAFETY INSTRUCTIONS, CAUTIONS, IMPORTANT NOTICES, and NOTES which must be followed to prevent the possibility of improper service, damage to the equipment, personal injury, or death. The following key words call the readers attention to potential hazards.

Hazards are identified by the "Safety Alert Symbol" and followed by a signal word such as "DANGER", "WARNING", or "CAUTION".

DANGER

Indicates an imminently hazardous situation which, if not avoided, will result in death or serious injury. This signal word is limited to the most extreme situations.

WARNING

Indicates a potentially hazardous situation which, if not avoided, could result in death or serious injury.

CAUTION

Indicates a potentially hazardous situation which, if not avoided, may result in minor or moderate injury.

NOTICE

Indicates that equipment or property damage can result if instructions are not followed.

SAFETY INSTRUCTIONS

Safety instructions (or equivalent) signs indicate specific safety-related instructions or procedures.

NOTE: Contains additional information important to a procedure.

Safety Icons Nomenclature

This manual and the equipment has numerous safety icons. These safety icons provide important operating instructions which alert you to potential personal injury hazards.

Personal Protection/Important Information

-  Read the manual
-  Maintenance procedure
-  Crush hazard
-  Eye protection
-  Hand protection
-  Head protection
-  Hearing protection
-  Inspect equipment
-  OEM parts only
-  Place in neutral
-  Protective shoes
-  Remove key
-  Damaged hazard label
-  Set parking brake
-  Slow vehicle placard
-  Stop engine
-  Support stand usage
-  Use proper tools
-  Visually inspect

Prohibited Actions

-  Do not alter or modify
-  Do not leave out tools
-  Do not weld
-  No alcohol
-  No children
-  No drugs
-  No open flame
-  No passengers
-  No riders
-  No smoking

Hazard Avoidance

-  Block wheels
-  Crushing hazard (body)
-  Crush hazard (foot)
-  Crush hazard (rolling over)
-  Defective or broken part
-  Entanglement hazard
-  Explosive separation hazard
-  Falling hazard
-  Fire hazard
-  High-pressure fluid hazard
-  Hose damage
-  Hot surface

-  Maintain safe distance
-  Overturn hazard
-  Pinch point hazard
-  Pressure alert / check pressure
-  Projectile hazard
-  Safety alert symbol
-  Sharp object hazard
-  Slipping injury
-  Tripping injury
-  Zero pressure

General Operating Safety

WARNING



Read And Understand Manual

To prevent personal injury or even death, be sure you read and understand all of the instructions in this manual and other related OEM equipment manuals! This equipment is dangerous to children and persons unfamiliar with its operation. The operator should be a responsible adult familiar with farm machinery and trained in this equipment's operations. Do not allow persons to operate or assemble this unit until they have read this manual and have developed a thorough understanding of the safety precautions and how it works.

This unit was designed for a specific application; DO NOT modify or use this unit for any application other than which it was designed.

Units operated improperly or by untrained personnel can be dangerous!



Hazard And Information Signs

Replace any missing or hard-to-read decals.

Decal placement and part numbers can be found in the Nomenclature section of this manual.



Damaged Parts Hazard

Do not use this unit if it is in need of repair. If you believe the unit has a defect which could cause damage, injury, or death, you should immediately stop using the unit.



Fall Hazard

Do not use the unit as a work platform. Do not stand on top of the unit at any time. Do not ride on the unit or allow others to ride on it.



Entanglement Hazard

Do not wear loose fitting clothing which may become entangled in moving parts.



Crush Hazard (Rolling Over)

When disconnecting the unit or leaving the operator's seat:

1. Stop the tractor or towing vehicle.
2. Shut off the engine and remove the ignition key.
3. Set the brakes.
4. Make sure wheel cylinder transport locks are attached.
5. Relieve hydraulic fluid pressure.
6. If parking the unit, make sure jack stand is lowered and retaining pin is installed.



Injury Hazard

Do not permit children to play on or around the stored unit.

WARNING



Impaired Operator Hazard

Do not attempt to operate this unit under the influence of drugs or alcohol. Review the safety instructions with all users annually.

Personal Protection Equipment

When working around or operating this unit, wear appropriate personal protective equipment. This list includes but is not limited to:



- A hard hat
- Protective shoes with slip resistant soles
- Protective goggles, glasses, or face shield
- Heavy gloves and protective clothing



Safe Distance

Keep all bystanders, especially children, away from the unit while in operation.

SAFETY INSTRUCTIONS



To prevent injury, use a tractor equipped with a Roll Over Protective System (ROPS).



Visually Inspect

Visually inspect the unit for any loose bolts, worn parts, or cracked welds, and make necessary repairs before using the unit.

Towing Safety

For towing safety information, refer to the Towing section.

Operation Safety

For operating safety information, refer to the Operation section.

Assembly Safety

For assembly safety information, refer to the separate Assembly manual.

Maintenance Safety

For maintenance safety information, refer to the Maintenance section.

Component Nomenclature

Component Locations

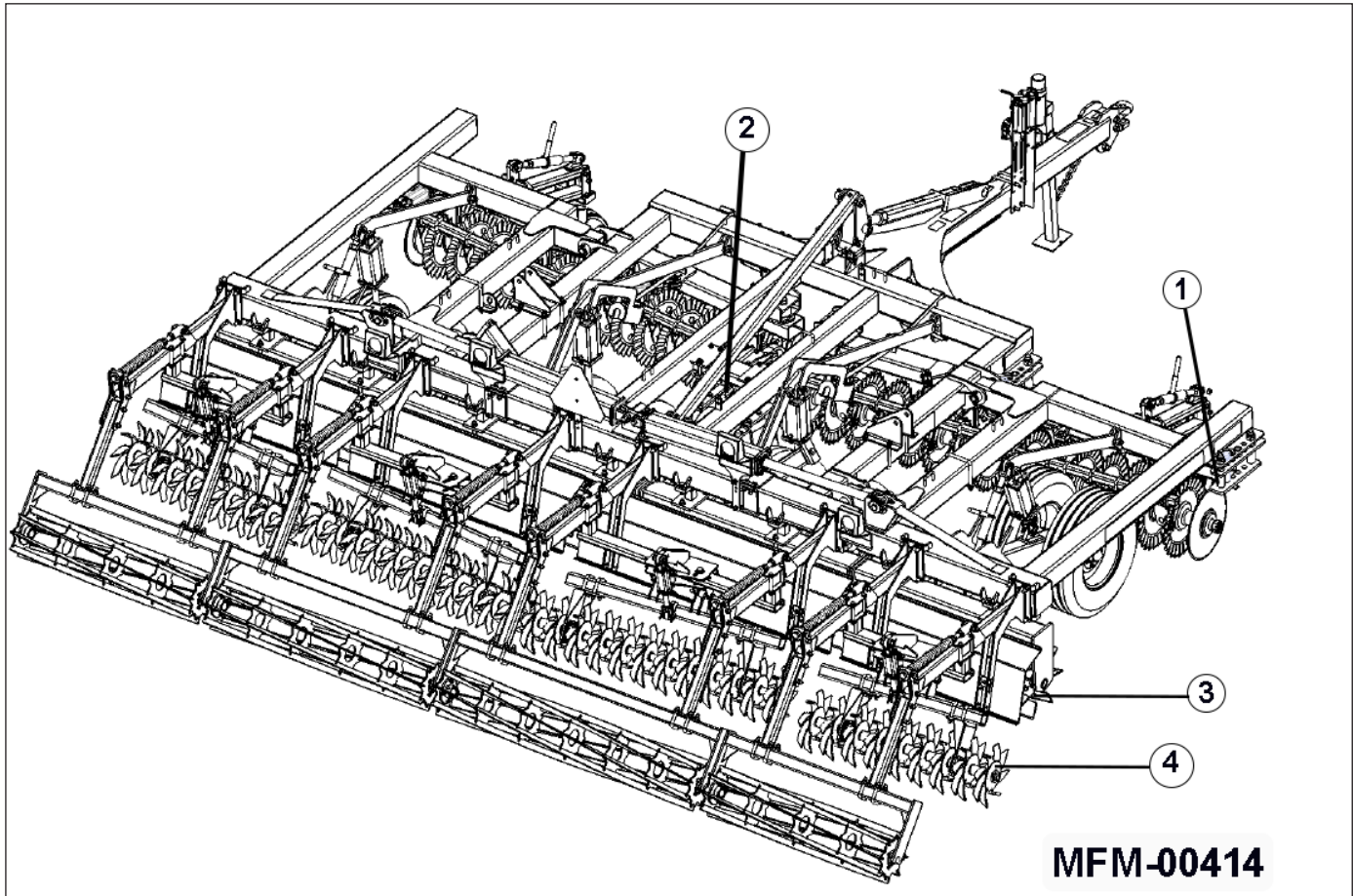

The Cobra is comprised of four components: (1) disk gangs, (2) wavy coulter and center covering disks, (3), Dura-Reel® and (4) finishing option (Spur-Till with a single rolling basket, 3-bar harrow with a single rolling basket, 5-bar harrow or double rolling basket).

NOTICE

In high residue situations, maximum down pressure on the disks is required to more completely cut the residue. In creating the maximum down pressure, make sure the C-spring stops do not constantly contact the frame, as this will cause equipment damage.

Specifications

Hydraulic Requirements

This unit operates with hydraulic pressures of 2500 to 3000 psi (170 to 205 bars).

Horsepower Range

CB-4212-STRB — 96 to 108
CB-4214-STRB — 112 to 126
CB-4220-STRB — 160 to 180
CB-4225-STRB — 200 to 250
CB-4230-STRB — 240 to 270
CB-4235-STRB — 280 to 315
CB-4245-STRB — 360 to 405

Tillage Depths

Disk gang depth up to 4" (10.2 cm)

Tongue Weight

Tongue weight of the unit is approximately 700 lbs. (318 kgs)

Overall Weight (GVWR)

CB-4212-STRB — 7,544
CB-4214-STRB — 8,091
CB-4220-STRB — 13,102
CB-4225-STRB — 15,719
CB-4230-STRB — 17,193
CB-4235-STRB — 21,053
CB-4245-STRB — 27,688

Transport Width

CB-4212-STRB — 13'9"
CB-4214-STRB — 14'8"
CB-4220-STRB — 13'4"
CB-4225-STRB — 15'4"
CB-4230-STRB — 15'4"
CB-4235-STRB — 17'4"
CB-4245-STRB — 19'2"

Transport Height

CB-4212-STRB — N/A
CB-4214-STRB — N/A
CB-4220-STRB — 9'6"
CB-4225-STRB — 10'5"
CB-4230-STRB — 12'0"
CB-4235-STRB — 13'6"
CB-4245-STRB — 13'6"

Working Tillage Width (Cut Width)

CB-4212-STRB — 12'3"
CB-4214-STRB — 14'2"
CB-4220-STRB — 19'10"
CB-4225-STRB — 25'8"
CB-4230-STRB — 30'2"
CB-4235-STRB — 35'9"
CB-4245-STRB — 45'8"

Field Capacity (acre/hr @ 6-9 mph)

CB-4212-STRB — 7-11
CB-4214-STRB — 10-12
CB-4220-STRB — 14-19
CB-4225-STRB — 18-24
CB-4230-STRB — 22-28
CB-4235-STRB — 26-33
CB-4245-STRB — 26-46

Towing Speed

Towing speeds should not exceed 20 mph (32 kph)
Field operating speeds should be 7-9 mph (11-14 kph).

Instructions for Display of Hazard and Informational Signs

- It is the responsibility of the customer to know the lighting and marking requirements of the local highway authorities and to install and maintain the equipment to provide compliance with the regulations. Add extra lights when transporting at night or during periods of limited visibility.
- Keep safety signs clean and legible at all times. Replace safety signs that are missing or have become illegible.
- Do not paint over, remove, or deface any safety signs or warning decals on your equipment. Observe all safety signs and practice the instructions on them.
- Replacement parts that display a safety sign should display the same sign.

- Make sure the hazard warning labels or other information decals are legible and attached to the unit before use.
- Safety signs are available from your Distributor, Dealer Parts Department, or the factory.

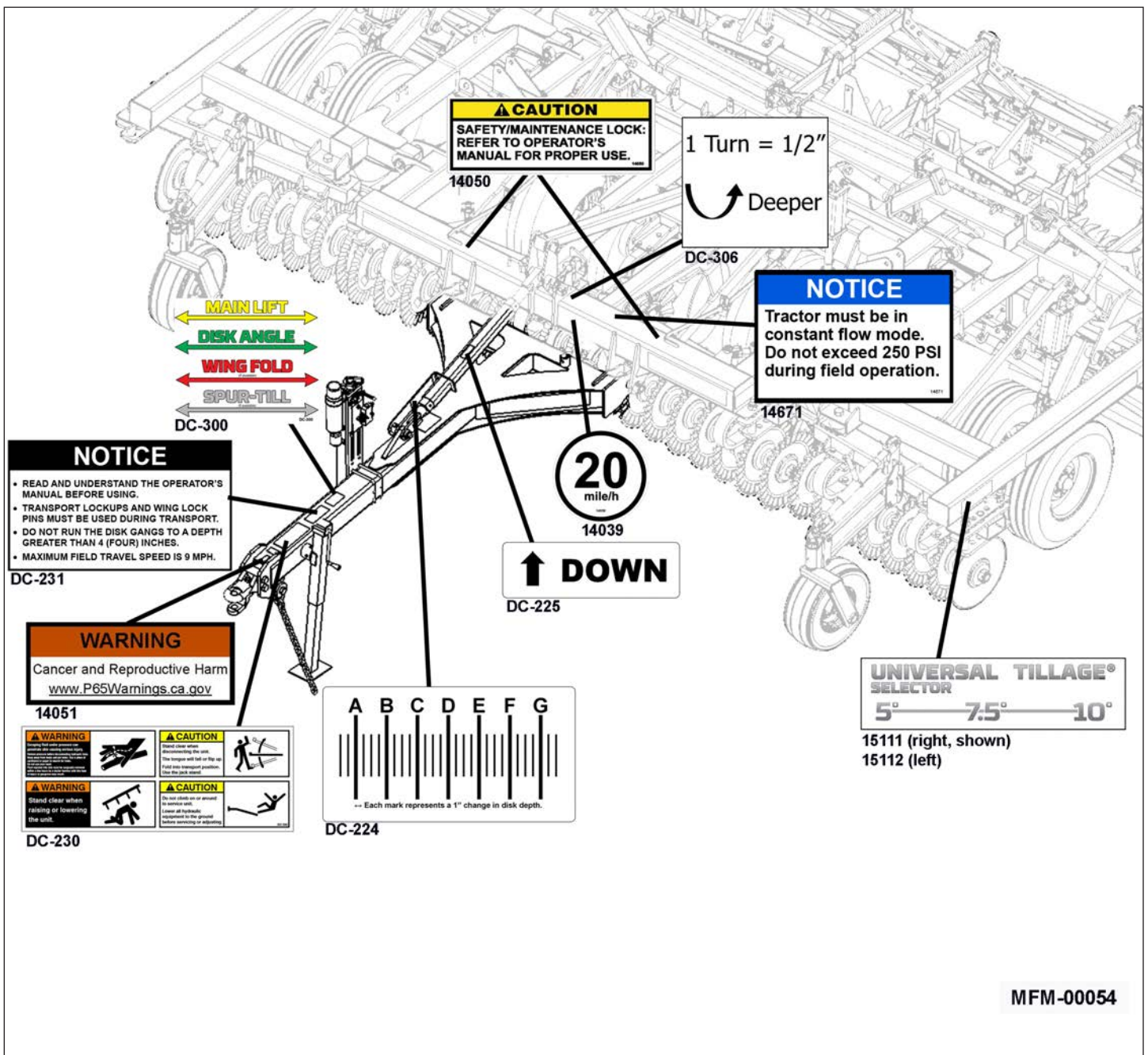

MFM-00054

⚠ WARNING

Escaping fluid under pressure can penetrate skin causing serious injury. Relieve pressure before disconnecting hydraulic lines. Keep away from leaks and pin holes. Use a piece of cardboard or paper to search for leaks. Do not use your hand. Fluid injected into skin must be surgically removed within a few hours by a doctor familiar with this type of injury or gangrene may result.



⚠ CAUTION

Stand clear when disconnecting the unit. The tongue will fall or flip up. Fold into transport position. Use the jack stand.



⚠ WARNING

Stand clear when raising or lowering the unit.



⚠ CAUTION

Do not climb on or around to service unit. Lower all hydraulic equipment to the ground before servicing or adjusting.

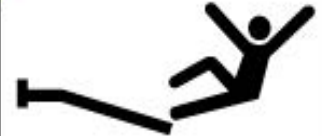

DC-230

NOTICE

- READ AND UNDERSTAND THE OPERATOR'S MANUAL BEFORE USING.
- TRANSPORT LOCKUPS AND WING LOCK PINS MUST BE USED DURING TRANSPORT.
- DO NOT RUN THE DISK GANGS TO A DEPTH GREATER THAN 4 (FOUR) INCHES.
- MAXIMUM FIELD TRAVEL SPEED IS 9 MPH.

DC-231

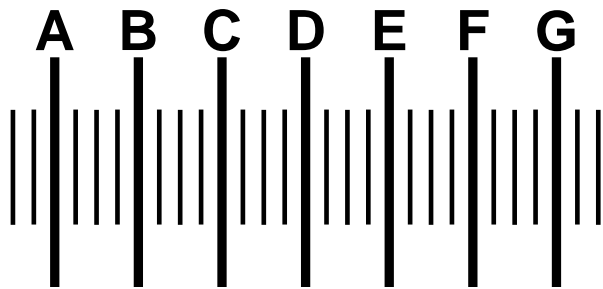

↔ Each mark represents a 1" change in disk depth.

DC-224

WARNING

Cancer and Reproductive Harm
www.P65Warnings.ca.gov

14051

1 Turn = 1/2"

 Deeper

DC-306

⚠ CAUTION

SAFETY AND MAINTENANCE LOCK:
SEE OPERATOR'S MANUAL FOR USE.

14050

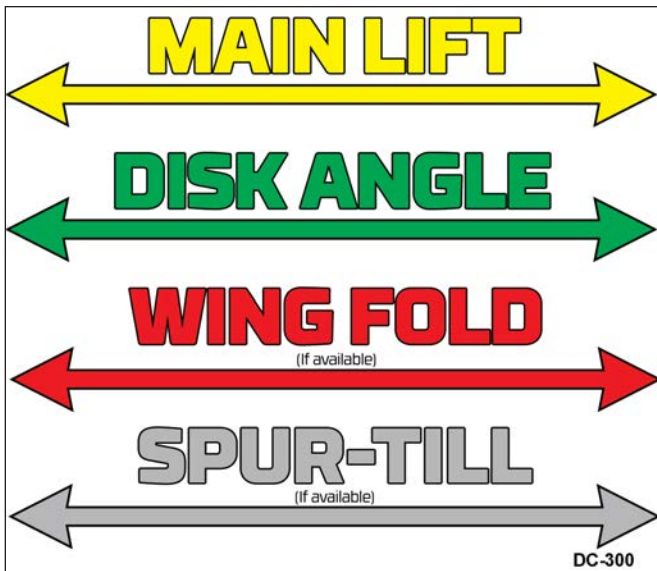

NOTICE

Tractor must be in constant flow mode. Do not exceed 250 PSI during field operation.

14671

Assembly

Refer to the separate Cobra Assembly manual for complete assembly instructions.

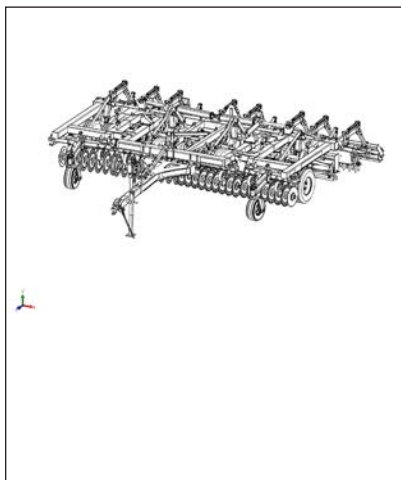

The assembly process consists of attaching the hitch to the main frame and attaching the lift arm/rolling basket subassemblies to the frame.

Approximate time to set up: 12'-14' = 2-4 hours, 20'-30' = 4-6 hours, 35'-45' = 8-10 hours

Cobra 4200 Series

Towing

General Safety

SAFETY INSTRUCTIONS

! Towing the Cobra requires care! Both the unit and tow vehicle must be in good working condition. Securely attach to towing unit. Use a high strength, appropriately sized hitch pin with a mechanical retainer and attach safety chain.

! Make sure the hitch and coupling on the towing vehicle are rated equal to, or greater than, the unit's "gross vehicle weight rating" (GVWR). Refer to the specification section.

! Make sure the safety chain is securely fastened to the tow vehicle.

 Check the tires for tread wear, inflation pressure, and overall condition.

 Inspect the hitch and coupling for wear or damage. **DO NOT** tow the unit using a defective hitch or coupling!

 Make sure directional, brake, and running lights are connected and working properly.

 Make sure the lug nuts holding the wheels are tight (torque to specifications) and that none are missing.



 When towing the unit on the highway, make sure the "Slow Moving Vehicle" placard is clearly visible.

 Do not allow anyone to stand between the tongue or hitch and the towing vehicle when backing up to the equipment.

 Make sure that the area is clear of children, animals, and other obstacles before using.





Safety Chain

SAFETY INSTRUCTIONS

- If the unit will be transported on a public highway, the safety chain must be attached to the tow vehicle.
-  Always follow state and local regulations regarding a safety chain when towing farm equipment on a public highway.
-  Be sure to check with local law enforcement agencies for any local regulations or restrictions.
- Do not use any device other than the safety chain that was supplied with the unit. Only a safety chain (not an elastic or nylon/plastic tow strap) should be used to retain the connection between the tow vehicle and the unit in the event of separation of the primary attaching system.

Bystanders

SAFETY INSTRUCTIONS

-  Beware of physical surroundings and especially bystanders, particularly children, before moving the unit! This is particularly important with higher noise levels and quiet cabs, as you may not hear people shouting.
-   **NO PASSENGERS ALLOWED** - Do not carry passengers anywhere on or in the tractor, except as required for operation.
-  Do not allow anyone to ride on the unit while it is moving.

Towing and Maximum Towing Speed

SAFETY INSTRUCTIONS

- Operate the towing vehicle from the operator's seat only.
- Do not exceed a towing speed of more than 20 mph (0.5 KPH) on a public roadway.
-  Remember, tires supplied by the manufacturer are designed to operate LESS THAN 20 mph. Do not exceed or tire failure may occur.

Highway and Transport Operations

SAFETY INSTRUCTIONS

- Make sure the wheel cylinder transport locks are installed, the wing lock pins are in place, and the jack stand is in its storage position before transporting the unit.

SAFETY INSTRUCTIONS

- Never use independent braking with unit in tow as loss of control and/or upset of unit may result.
- Always drive at a safe speed relative to local conditions and ensure that your speed is low enough for an emergency stop to be safe and secure. Keep speed to a minimum.
- Reduce speed prior to turns to avoid the risk of overturning.
- Avoid sudden uphill turns on steep slopes.
- Always keep the tractor or towing vehicle in gear to provide engine braking when going downhill. Do not coast.
- Use approved accessory lighting or flags and necessary warning devices to protect operators of other vehicles on the highway during daylight and nighttime transport. Various safety lights and devices are available from your dealer.
- The use of flashing amber lights is acceptable in most localities. However, some localities prohibit their use. Local laws should be checked for all highway lighting and marking requirements.
- When driving the tractor and equipment on the road or highway, use flashing amber warning lights and a slow moving vehicle (SMV) identification emblem.
- Be a safe and courteous driver. Always yield to oncoming traffic in all situations, including narrow bridges, intersections, etc. Plan your route to avoid heavy traffic.
- Be observant of bridge loading ratings. Do not cross bridges rated lower than the gross weight at which you are operating.
- Watch for obstructions overhead and to the side while transporting.
- Always operate equipment in a position to provide maximum visibility at all times. Make allowances for increased length and weight of the equipment when making turns, stopping, etc.

Pre-towing Checklist

1. Before towing, make sure the maintenance on the tractor and the unit are current. This is very important because towing puts additional stress on the tow vehicle.
2. Check and correct the tire pressures on the tow vehicle and the unit. Refer to the Tire and Lug Torque specification chart in the manual.
3. Make sure the hitch, coupler, and any other equipment that connects the unit and the tow vehicle are properly secured and adjusted. Always inspect the hitch and tongue for cracks when hooking up.

! WARNING

! Substandard Parts Hazard
If towing the unit with a draw bar, use only an OEM certified, hardened drawbar pin with a retainer clip. Do not use homemade pins, bolts, or any other type of retaining device. Always install the retainer clip, making sure the hitch and unit are securely fastened to the tow vehicle.

Using a pin not intended for this type of towing, can result in unexpected separation of the unit from the tow vehicle resulting in equipment damage and personal injury.

4. Verify the appropriate Category 3 or Category 4 hitch is securely installed.

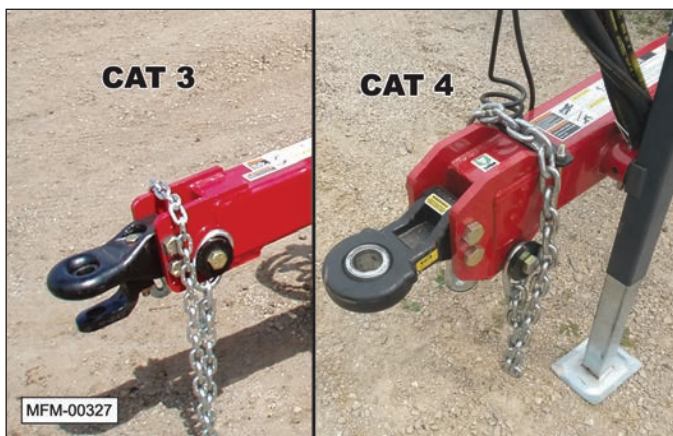

! WARNING

! Unexpected Separation Hazard
If the safety chains do not have a current certification tag, do not use the unit until properly certified chains are installed. Substandard safety chains could allow the unit to separate from the tow vehicle resulting in equipment damage and personal injury.

5. Attach the safety chain from the unit to the tow vehicle. The safety chain should be long enough for tight turns. Don't allow the chain to drag on the pavement because it will wear the chain links causing an unsafe condition.
6. Make sure the electrical wiring harness for the running lights and taillights is properly connected and not touching the road, but loose enough to make turns without disconnecting or damaging the wires.
7. Have an observer confirm all running lights, brake lights, turn signals, and hazard lights are working on both the tow vehicle and the unit.
8. Verify the brakes on the tow vehicle are operating correctly.
9. Make sure transport locks are securely in place around the cylinder rods.
10. Make sure the jack stand is raised and locked in the storage position.
11. Make sure the wing lock pins are in place.
12. Check mirrors of the tow vehicle to make sure you have good visibility.
13. Check routes and restrictions on bridges and tunnels.

Safety

SAFETY INSTRUCTIONS

Make sure that anyone who will be operating the unit or working on or around the unit reads and understands all the operating, maintenance, and safety information in the operator's manual and other related OEM equipment manuals before using or towing the unit.



Prior to Connecting Unit

Make sure the unit is resting on the ground or the transport locks are securely installed over the wheel cylinder rods before attaching the unit to the tractor.



SAFETY INSTRUCTIONS



If the unit is not resting on the ground, make sure wheel chocks are securely fitted on both sides of each wheel.

⚠️ WARNING



Crush Hazard

The tongue weight of the unit is approximately 700 lbs. (318 kgs.). Use care when lifting or attaching the unit to the tractor. Never place any part of your body under the tongue or hitch assembly.



Hydraulic Pressure

This unit operates with hydraulic pressures of 2500 to 3000 psi (170 to 205 bars).



High-Pressure Fluids

1. Check or tighten all connections BEFORE pressurizing system.

2. Release all pressure before removing hoses and/or valves by:



a. Stopping engine.

b. Holding hydraulic control levers in float or neutral position.



3. DO NOT use your bare hand to check for potential leaks. Always use a board or cardboard when checking for a leak.

Escaping hydraulic fluid under pressure, even a pinhole size leak, can penetrate body tissue, causing serious injury and possible death. If fluid is injected into your skin, it must be treated immediately by a doctor familiar with this type of injury.

Tow Chain



certified tow chain is supplied with each unit. This chain must be attached to the tractor during towing or operation of the unit.

SAFETY INSTRUCTIONS



Inspect the chain annually for wear or damage.



Do not replace the chain with anything other than an OEM certified replacement.

Connecting to the Tractor

1. Raise the jack stand and connect the tongue to the tractor. The tongue weight of the unit is approximately 700 lbs. (318 kgs).



Note: If a drawbar pin is used, it should be an OEM certified pin and retainer clip. On category 3 pintle hitches use a 1-1/2" (38 mm) pin. On category 3 clevis hitch use a 1-1/4" (32 mm) pin. On category 4 articulating ball pintle hitch use a 2" (51 mm) pin.

WARNING

! Unexpected Separation Hazard
If towing the unit with a drawbar, use only a certified, hardened drawbar pin with a retainer clip. Do not use homemade pins, bolts, or any other type of retaining device. Always install the retainer clip, making sure the hitch and unit are securely fastened to the tow vehicle.

Using a pin not intended for this type of towing can result in unexpected separation of the unit from the tow vehicle, resulting in equipment damage and personal injury.

2. Connect the hitch of the unit to the tractor. Attach the tow chain to the tractor's draw bar cage.



Note: When connected, make sure the retaining plate securely locks the chain link in place.



3. Remove the jack stand and place it in its storage position inside the frame, as shown.

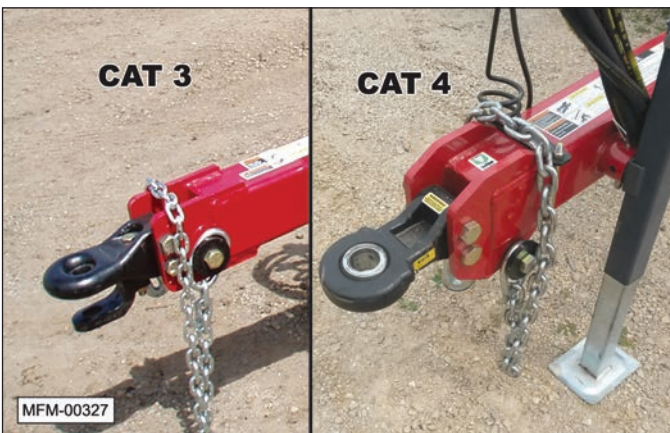



2. Connect the hydraulic hoses to the tractor.

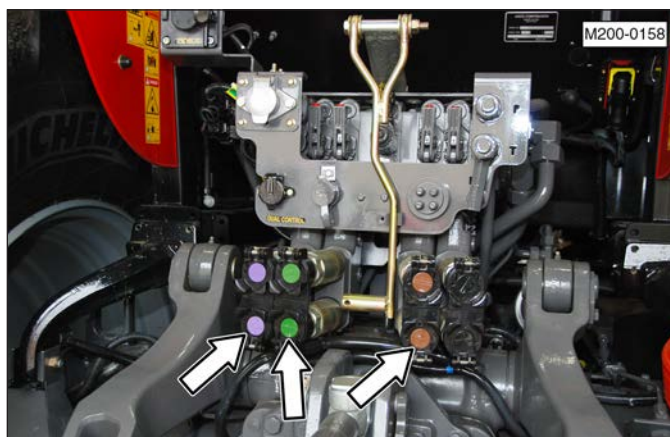

Note: The most commonly used function of the unit is the “main lift” cylinders, which raises and lowers the wheels. Connect the hydraulic hoses for this function into the port (control lever) used most commonly.

1. Remove the hydraulic hoses from their storage position.



3. Disconnect the electrical connection for the rear lights from the storage socket.



a. Rotate the plug.

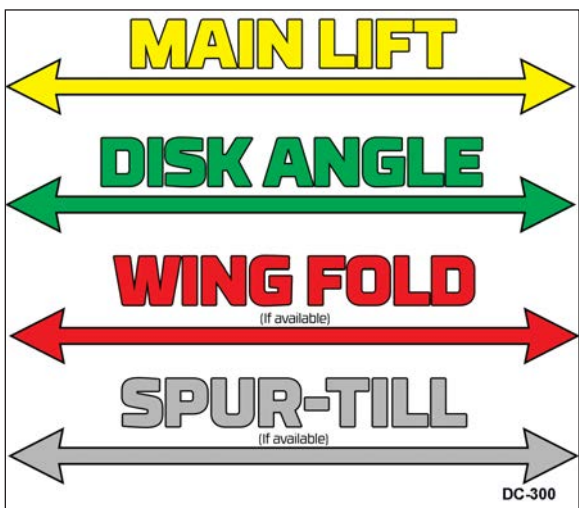

b. Push the plug upward and slightly rotate it again to release it from the socket.



c. Pull the plug downward.

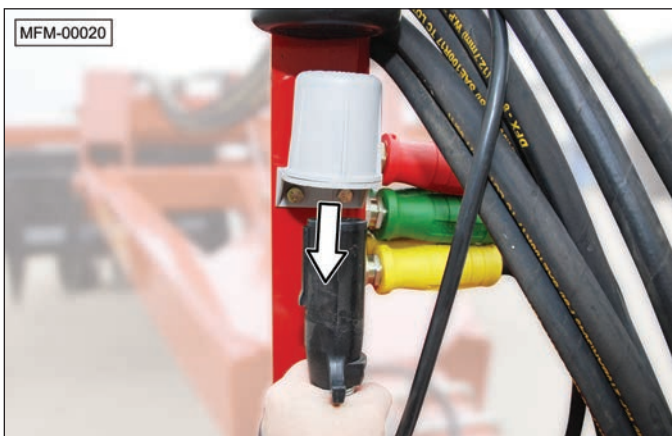

d. Connect the plug into the tractor's electrical socket.

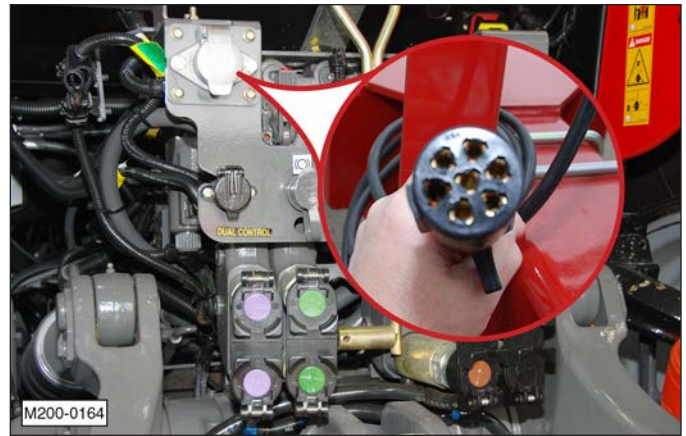

1. Make sure all the hydraulic cylinders are functioning properly.
2. Make sure the amber and red indicator lights are working properly.
3. Move the unit to the desired location and position it for operation following the towing recommendation provided in this manual and/or any other local, State, or Federal regulations that may apply.

Operation

Safety

⚠️ WARNING

To prevent serious injury or death, follow these safety instructions



Entanglement Hazard
Keep hands and clothing clear of moving parts.



Crush Hazard (Rolling Over)
Do not clean, lubricate, or make adjustments while the unit is moving.



Crush Hazard (Rolling Over)
When making adjustments to the unit or leaving the operator's seat:



1. Stop the tractor.
2. Shut off the engine and remove the ignition key.
3. Set the brakes.



Overturn Hazard
Pick the levellest possible route when transporting across fields. Avoid the edges of ditches or gullies and steep hillsides.



Safe Distance
Keep all bystanders, pets, and livestock clear of the work area, particularly when raising or lowering the unit.

SAFETY INSTRUCTIONS



Periodically clear the unit of brush, twigs, or other materials to prevent buildup of dry, combustible materials.

NOTICE

*DO NOT turn while the unit is in the ground.
DO NOT operate the unit in frozen ground.*

Initial Setup

The McFarlane Cobra is a tool that is designed to handle a wide variety of field conditions. It has many adjustments that can be made to change the performance of each component on the unit as well as its overall performance. Achieving the best results over the widest range of circumstances can be accomplished by making adjustments to match the field conditions.

Note: It is important to make one adjustment at a time in order to see the results of each change. If several adjustments are made at the same time, the operation of the machine can change dramatically, creating confusion and frustration.

⚠️ WARNING



Pinch Point Hazard
Do not place hands or fingers between moving and/or stationary parts. The weight of the unit will easily cause serious bodily injury.



Sharp Object Hazard
Do not place any part of your body under the disk gang during the adjustment process. Severe injury will occur if a person contacts or falls under the disk gang.

1. If equipped with wings, remove the wing fold lock pins and bridge pins and store them on the hitch storage bracket.

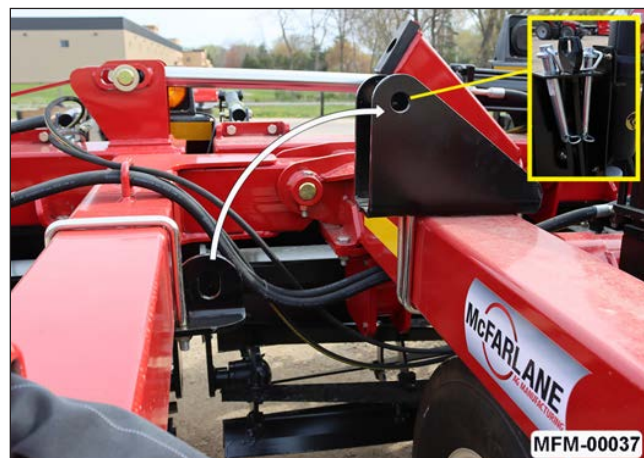

2. If necessary, raise the unit and release the transport locks from both wheel cylinders.

- a. Remove the retainer clip and rotate the lock plate upward.
- b. Now pull up on the release lever and pull back to release the transport locks from the cylinder.
- c. Lock the release lever in the locked position, lower the locking plate, and reinstall the retainer clip.



- a. Lower the disk gang close to the ground but not touching.



Do not place any part of your body under the disk gang.

WARNING

To prevent serious injury or death from rolling over or crushing during the setup procedure:



Stop tractor's engine.



Set parking brake.

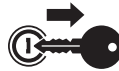

Remove ignition key.



Block wheels of unit.

- b. Stop the tractor, shut off the engine, set the parking brake, and remove the ignition key from the tractor.
- c. Release the wire retainer clips and remove the retainer pins.

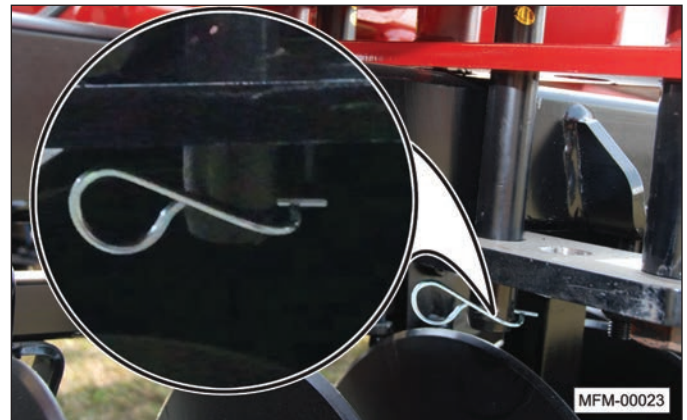

- d. Adjust the disk gang to the desired angle.

Disk Gang Adjustment

3. Adjust the disk gang angle by repositioning the retainer pins and moving the disk gang into the desired position using the following procedure.

Note: On models with wings, make sure the disk gang wing is unfolded before starting the adjustment procedure.



The 5° angle is the least aggressive setting and is typically used with higher speeds and smaller amounts of residue.

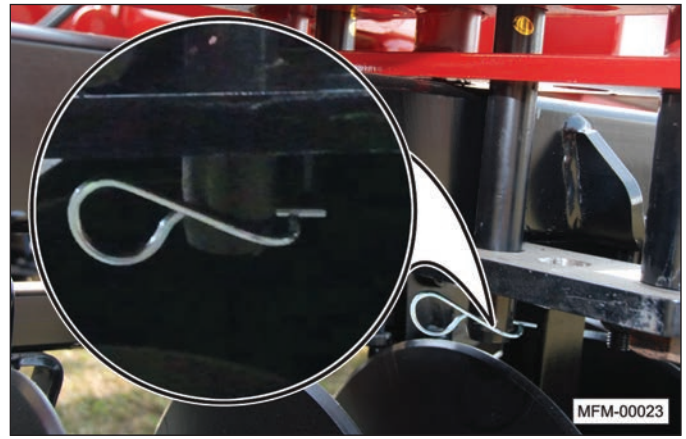

4. Start the tractor and use the tractor's control lever to lower the wheels (raise the disk gang) to the maximum height.
5. Begin to pull the unit through the field.
6. Slowly raise the wheels until the disks contact the ground.



The 10° angle is the most aggressive setting and is used for heavy or difficult residue. This setting also requires the most horsepower. It may also be necessary to reduce the speed at this steeper gang angle to prevent ridging.

Note: Begin tilling with the disk gang angle set at 7.5°. If necessary, after operating the unit, increase or decrease the aggressiveness of the disk gangs per the condition of the soil. To prevent ridging, it may be necessary to reduce the travel speed with more aggressive disk angles.

- f. Set the remaining disk gangs to the same angle. Reinstall the two retainer pins and fasten the wire retainer clips.



7. Continue raising the wheels (lowering the unit) until the disks are cutting into the ground.

Machine Leveling

Once the desired depth is reached (no more than 4 inches), the unit must be leveled by adjusting the frame leveling turnbuckle.

Raise the locking mechanism from the turnbuckle.



Use the wrench (stored behind the hitch) to make the adjustment.



Note: As viewed from the front of the unit, turning the turnbuckle counterclockwise will raise the hitch end and lower the Dura-Reel end.

- e. Record the current location on the depth gauge that is located on the turnbuckle lock. Each mark on the depth gauge represents a 1" change in disk depth. Example, changing from B0 to C0 will produce 4 inches of change.

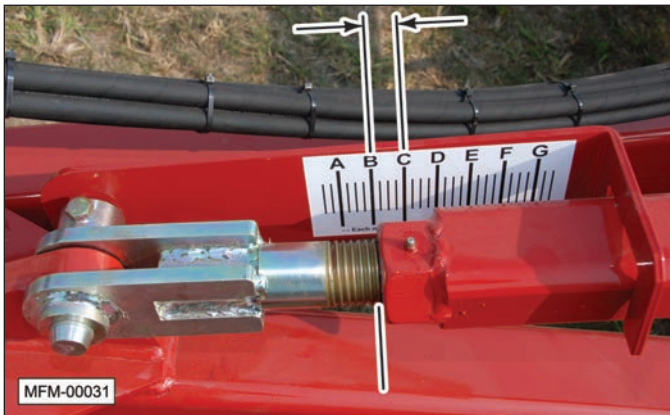

- f. Check the frame for levelness. Adjust the turnbuckle as needed.
- g. Once the unit is level from front to back, and the disks are cutting at the desired depth, place the locking mechanism over the turnbuckle.



Note: When a major change is made to the depth of the front gang disks or the Dura-Reels, make sure the frame is still level.

- 8. Stop the tractor with the unit still in the ground.

WARNING



Before leaving the tractor, shut off the engine, set the parking brake, and remove the ignition key.

- 9. Measure the depth the disk is cutting into the ground.

Note: The desired depth (no more than 4 inches) of the disks is controlled by a hydraulic valve. When the wheels of the unit are raised, the stop crank actuates the valve, stopping oil flow. Each time the wheels are raised and lowered, the valve will consistently position the depth of the unit.

- 10. Adjust the angle of center disks, if necessary. Adjust the center disks with more or less angle to prevent ridges or gaps from forming between the two inner disk gangs. Also, the depth of the coulter disk can be changed by adding or removing spacers.

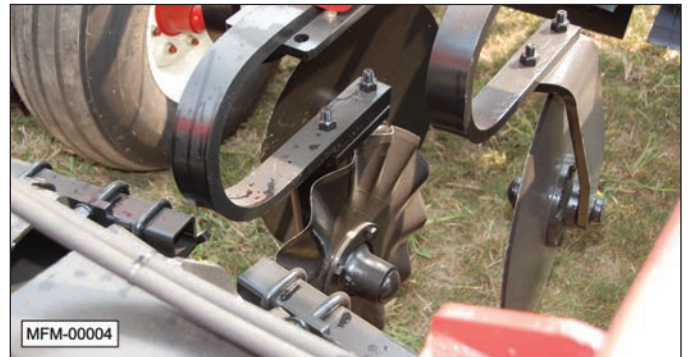

Note: It may only be necessary to change the angle of the center disks when the disk gangs are set to steeper angles. The angle of the center disks can also be changed by loosening the back bolt of the mounting bracket and twisting to the desired angle.



11. Position the height of the disk gang gauge wheels (on winged models only). With the disks in the ground at the desired depth, lower the gauge wheels to carry some of the wings weight, but not enough to prevent the wing from reaching the depth of the main frame components.



- a. Loosen the jam nut located on the gauge wheel ratchet cylinder with the adjustment wrench provided.

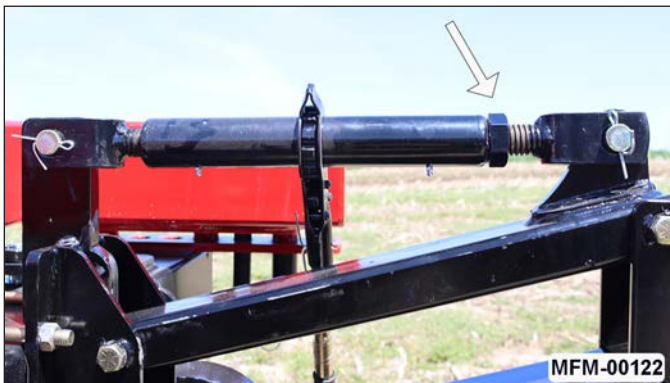

- b. Shortening the turnbuckle will raise the wheel, allowing the disks to go deeper into the ground.

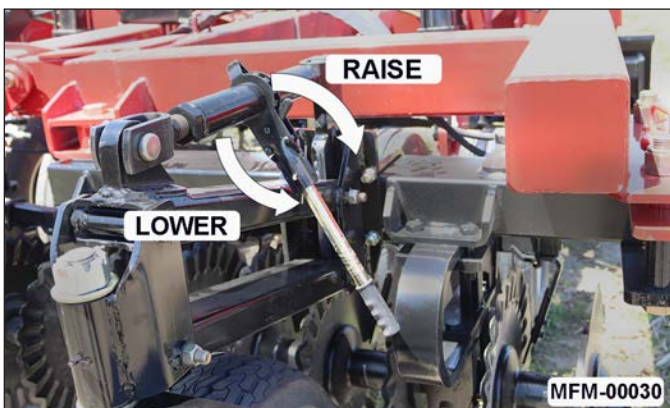

- c. Verify that all gauge wheels have been adjusted equally by measuring the pin to pin distance of the

ratchet cylinders.

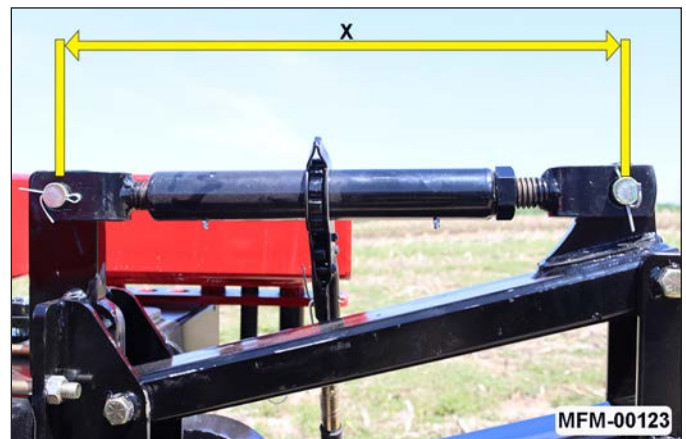

- d. Securely tighten the jam nut.

Note: The gauge wheels are not designed to prevent the disks from working deeper than originally set. The gauge wheels must be readjusted whenever the disk depth is changed. During operation, the gauge wheels should be observed to have some side to side “castering” motion.

Dura-Reel Adjustment

12. Adjust the depth of the Dura-Reel. The Dura-Reel will generally run at the same depth as the disk gangs. Adjust the depth stop valve to prevent the Dura-Reel from going too deep.

- a. Raise the wheel cylinders until the Dura-Reel is operating at the approximate desired depth.
- b. Turn the stop crank (depth control) to fully depress the pin on the hydraulic stop valve.
- c. Pull the Cobra through the field and stop the unit without raising it.
- d. Check the depth of the Dura-Reel blades and adjust the stop crank accordingly.
- e. If the Dura-Reel blades need to be reset, turn the stop crank accordingly; two full turns of the crank equals 1 inch of depth adjustment.

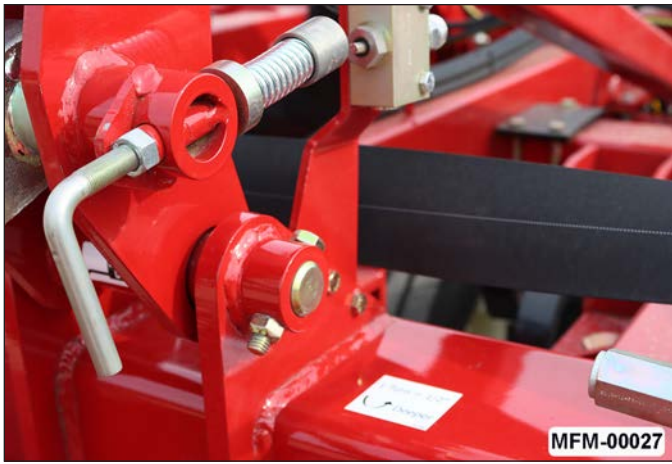

1 Turn = 1/2"

 Deeper

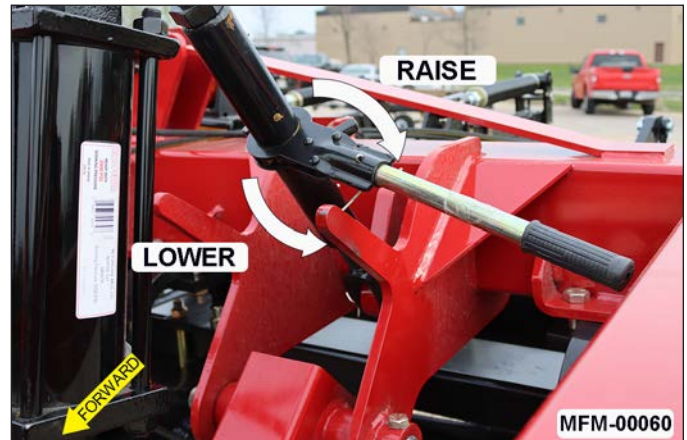

Note: Since the wheels position the height of the entire frame of the unit, the depth setting of the other components also needs to be checked and possibly readjusted any time the disk depth is changed.

13. Continue pulling the unit through the field and raise and lower the Dura-Reel to allow the hydraulic control valve to stop the unit at the set depth. Stop the tractor and check the depth of the disks and the Dura-Reel, making sure they are the desired depth. Readjust the depth control device and the hitch frame turnbuckle, if necessary. The disk blades should be cutting slightly deeper than the reels.

Harrow and Rolling Basket Adjustment

1. Adjust the aggressiveness of the harrow sections. There are three attachment points on the first harrow bar to control the aggressiveness of the harrow.
 - a. In the least aggressive direction, mounting hole #1 will cause the sections to lay more flat (less aggressive).
 - b. In position #2, the teeth are in approximately a 45° position (more aggressive).
 - c. In position #3, the teeth are at the most aggressive angle (more upright).

Note: Typically, the angle should be set more aggressive for increased soil leveling and less aggressive in heavy residue conditions.

The steeper the angle of attack, the more aggressive the harrowing will be. In the least aggressive angle, use the pull hook in the top position, as shown.

In some situations that do not require the extra leveling of the harrow section, such as heavy fall residue, the sections can be removed or raised above the ground level.

⚠ WARNING



Before leaving the tractor, shut off the engine, set the parking brakes, and remove the ignition key.

Leveling Wing Frames

14. Level the wing frames. This prevents the disk gangs from gouging and/or ridging. It also ensures a consistent operating depth across the width of the tillage area.
 - a. Rotate the turnbuckle either clockwise or counterclockwise to level the wings from side-to-side.
 - b. The gauge wheels may also need to be adjusted once the wing frames are set.

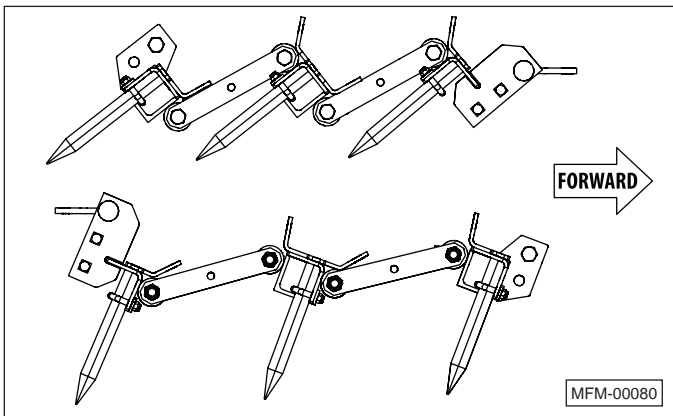
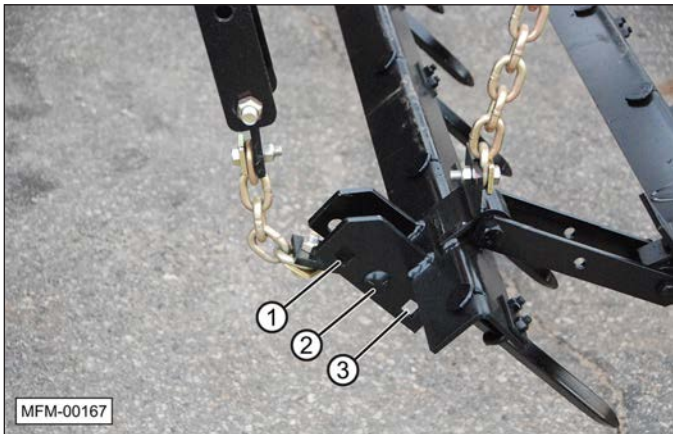
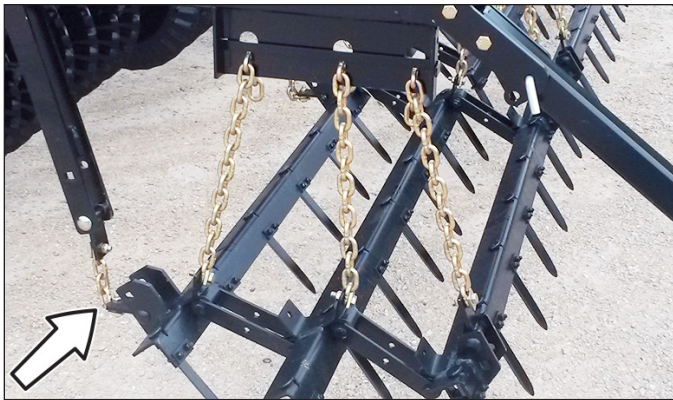

2. Adjust the height of the harrow sections.



a. Remove the locking bar retainer clip.



b. Remove the locking bar.



c. Raise or lower each harrow bar to the desired height.

Typical spring (finishing) settings are all three chains set with three links hanging.

Typical fall settings in heavy residue are front chain with seven links hanging, middle with six, and rear with five links hanging (front bar higher than rear bar).

Note: Make sure the chains are not twisted when inserting into the slot.

d. Replace the locking bar and clip.

Note: To maximize the unit's performance, it should be operated at speeds ranging from 7 to 9 mph (11 to 14 kph). This keeps the field debris moving through the harrow sections and avoids clogging.

3. Adjust the rolling basket height and tension.

- a. Place the rolling basket on a flat, level surface.
- b. Adjust the turnbuckle to either raise or lower the rolling basket. To adjust the turnbuckle, use the wrench provided on the front of the unit.

- c. Loosen the jam nut on the front of the turnbuckle, and turn the adjusting nut on the rear of the turnbuckle to raise or lower the rolling basket. Set the rolling basket height so it just touches the ground.



- d. Make sure all the rolling baskets are adjusted to the same height. Failure to do so will result in uneven seedbed conditions and could damage the rolling basket arms and/or bearings.
- e. If the spring or other components are replaced, tighten the adjusting nut to compress the spring 1/4". Make sure the jam nut is securely tightened against the adjusting nut.
- f. During operation the spring should only lightly compress. Too much spring tension will cause premature failure, especially when going through waterways or ditches.

Spur-Till Operation and Adjustment

The McFarlane Spur-Till treader is designed to mix soil with residue, pulverize large clods, remove soil from exposed root balls and anchor residue to the soil surface.

Note: The Spur-Till comes assembled at 5 degrees.

The Hydraulic Cylinder Support with constant down pressure is self-adjusting for unit depth and will maintain a uniform pressure over rolling terrain. As the unit is lowered, the Spur-Till treader will find its working position based on the set pressure applied. When the unit is raised the treader will lower to the maximum down position. We recommend hydraulically raising the Spur-Till for transport and going in and out of driveways or waterways.

Operating with Constant Hydraulic Flow

1. The tractor SCV for the treader function must be set to constant hydraulic flow. Refer to your tractor manual to set your tractor hydraulics to this mode. This may also be referred to in your tractor manual as the setting required for hydraulic motors. If your tractor does not have this feature, the tractor SCV for the Spur-Till must be run in the float position. Make sure the tractor constant flow port is connected to the Cobra gray grip that leads to the pressure reducing valve port just ahead of the gauge.

2. Lowering the flow rate to 25% of full flow will reduce the heat build up in the hydraulic oil.

Spur-Till Depth Adjustment

3. Check the pressure gauge reading with the Cobra connected to the tractor and operating in the constant flow mode. It should be set initially at 200 psi. To increase Spur-Till depth, the pressure can be increased by loosening the locking nut and rotating the knob clockwise. Be sure to lock the nut after finishing the adjustment. The pressure should not exceed 250 psi.

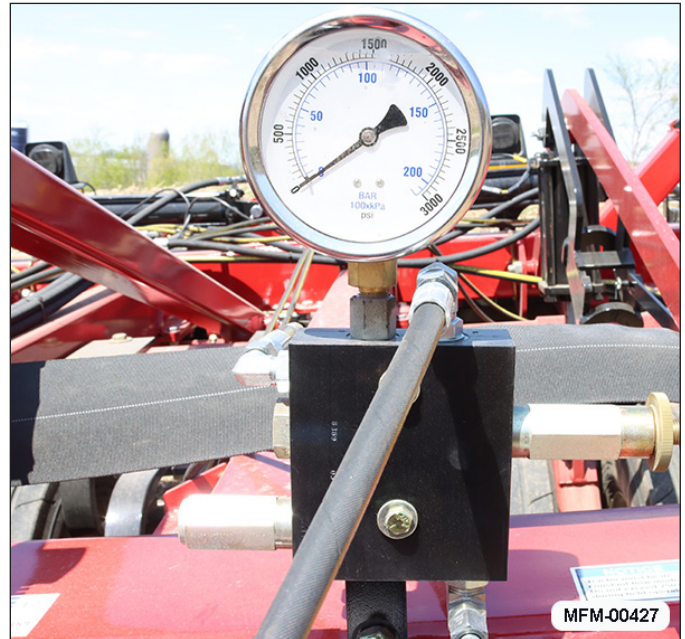

Spur-Till Angle Adjustment

The Spur-Till can run at a 0° to 15° angle, and is set at 5° when delivered.

To adjust the angle of the Spur-Till, loosen both 3/4" bolts and manually rotate the Spur-Till to the selected angle point.

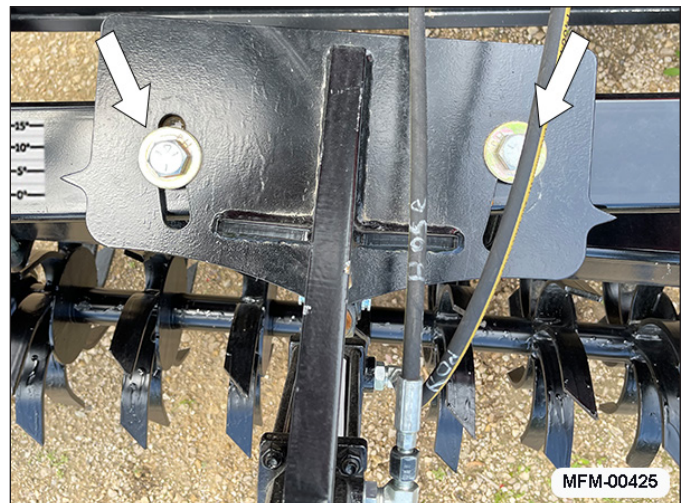

Note: When adjusting the Spur-Till to 0°, it is important to

completely remove the bolt and place it the single hole on the pivot plate.

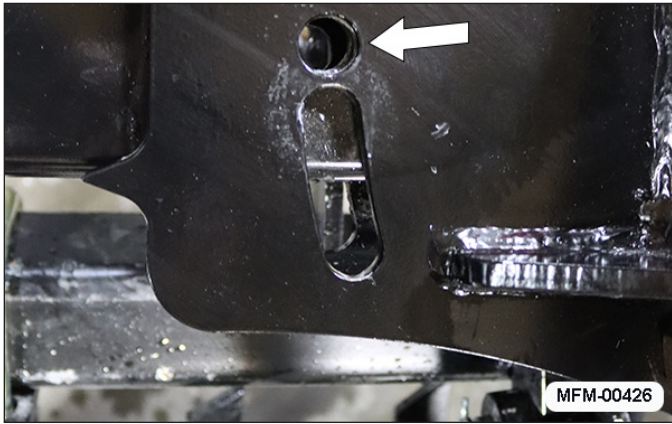

For residue pinning and soil firming, set the Spur-Till to 0°. When adjusting the Spur-Till to 0°, it is important to completely remove the bolt and place it the single hole on the pivot plate.

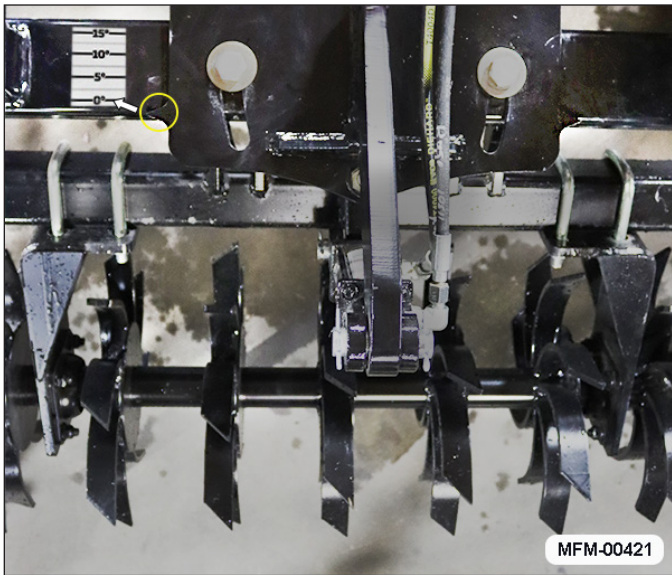

For minimal soil mixing, set the Spur-Till to 5°.



For increased root exposure, residue and soil mixing as well as residue incorporation, set the Spur-Till to roughly 10°.

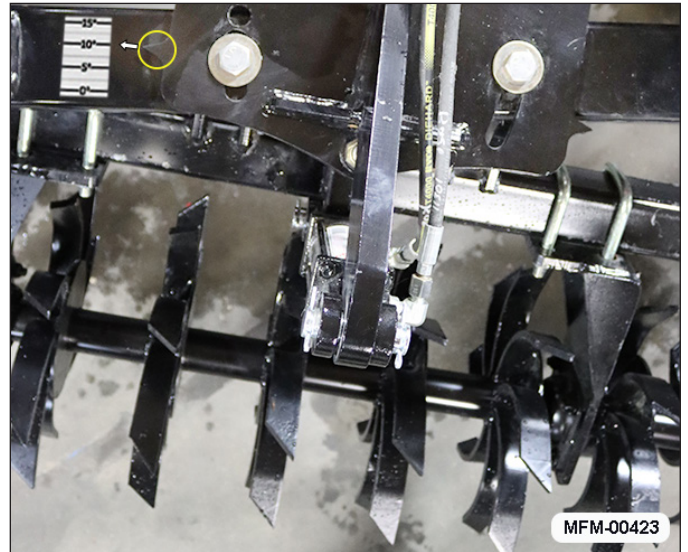

For maximum root exposure and soil mixing, set the Spur-Till to the steepest and most aggressive angle (15°).

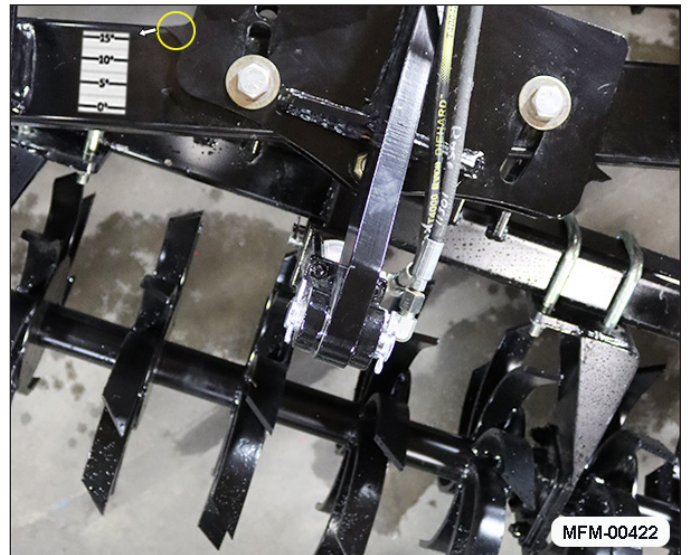

The unit should now be ready.

Preparing for Transport

1. Lower the wheels and lift unit off of the ground. Fold the wings into the wing rests.





 Use Properly Rated Tools
 Use sufficient tools, jacks, and hoists that have the capacity for the job.

 Crush Hazard
 Use support blocks or safety stands rated to support the load when changing tires or performing maintenance.

 High-Pressure Fluids
 Never use your hands to locate a hydraulic leak. Use a piece of cardboard or wood. Wear proper hand and eye protection when searching for a high-pressure hydraulic leak.

Hydraulic fluid escaping under pressure can penetrate the skin. Openings in the skin and minor cuts are susceptible to infection from hydraulic fluid. If injured by a concentrated high-pressure stream of hydraulic fluid, seek medical attention immediately. Without immediate medical treatment, serious infection or toxic reaction can develop if hydraulic fluid penetrates the surface of the skin.

 Entanglement Hazard
 Keep hands, feet, clothing, jewelry, and long hair away from any moving parts to prevent them from getting caught.

2. Install the wing fold lock pins and bridge pins.







3. Push the transport locks into place over the cylinder rods. Lock the release lever in place and install the bridge pin.

Maintenance

Safety

WARNING

To prevent serious injury or death:

     Rolling Over / Crush Hazard
 To prevent serious injury or death, before servicing, adjusting, repairing, or performing other work on the unit, always make sure the tractor or towing vehicle engine is stopped, the ignition key is removed, the unit is lowered to the ground, all controls are placed in neutral, the parking brake is set, and all hydraulic fluid pressure is relieved (zero pressure).

 Rolling Over Hazard
 Block the wheels before performing maintenance or repairs.

**SAFETY
INSTRUCTIONS**

Follow all operating, maintenance, and safety instructions found in this manual.



Understand the service procedure before performing the work. Keep area clean and dry.



Replace all worn or damaged safety and instruction decals.



Keep all parts in good condition and properly installed. Fix damage immediately. Replace worn or broken parts.



Do not leave tools lying on the unit.



Do not modify machine or safety devices. Do not weld on the unit. Unauthorized modifications may impair its function and safety.

If equipment has been altered in any way from the original design, the manufacturer does not accept any liability for injury or warranty.



Never replace hex bolts with less than Grade 5 bolts unless otherwise specified. In locations where grade 8 bolts are used, grade 8 replacements are required.





Where replacement parts are necessary for periodic maintenance and servicing, genuine factory replacement parts must be used to restore the unit to original specifications. The manufacturer will not claim responsibility for damages as a result of the use of unapproved parts.

Tire and Lug Torque Specifications

Model	Tire Size	Tire Pressure	Lug Size	Lug Torque (lb.ft.)		Tire and Wheel Weight
				Min	Max	
MAIN FRAMES						
CB-4212, CB-4214	IF 280/70R15 (4)	64	1/2"	75	85	85
CB-4220	IF 320/70R15 (4)	70	9/16"	80	90	103
CB-4225, CB-4230, CB-4235	IF 320/70R15 (4)	70	9/16"	85	100	159
CB-4245	VF 285/70R19.5 (4)	75	5/8"	85	100	159
WING FRAMES						
All Models	IF 280/70R15 (4)	64	1/2"	75	85	85

Bolt Torque Chart

Bolt Head Markings	 No Marking		 3 Radial Lines		 6 Radial Lines	
	SAE Grade 2 N·m (ft-lbs)		SAE Grade 5 N·m (ft-lbs)		SAE Grade 8 N·m (ft-lbs)	
1/4"	8	(6)	12	(9)	17	(12)
5/16"	13	(10)	25	(19)	36	(27)
3/8"	27	(20)	45	(33)	63	(45)
7/16"	41	(30)	72	(53)	100	(75)
1/2"	61	(45)	110	(80)	155	(115)
9/16"	95	(70)	155	(115)	220	(165)
5/8"	128	(95)	215	(160)	305	(220)
3/4"	225	(165)	390	(290)	540	(400)
7/8"	230	(170)	570	(420)	880	(650)
1"	345	(225)	850	(630)	1320	(970)

Maintenance Schedule

1. After the first 12 hours of use:

- a. Make sure all retaining hardware is installed. Check the tightness of all the bolts, especially those on the C-springs. Torque specifications are listed in the Bolt Torque Chart in this manual.



Cotter pin and hairpin clips.



Bridge pins.

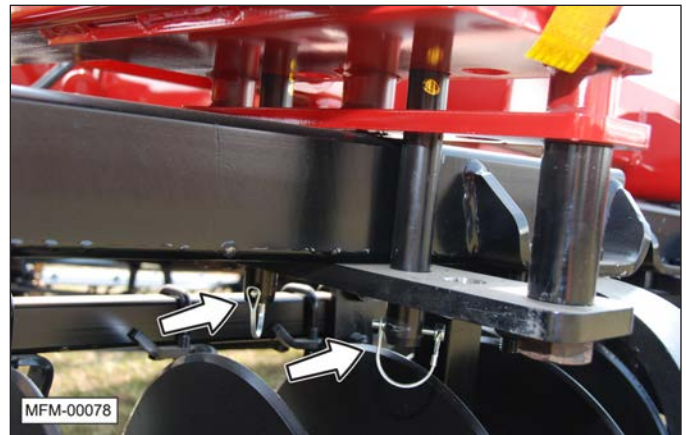

Retainer pins with wire retainer clips.

- b. Check the gang arbor bolt torque which is defined in the “Disk Gang and Blades” section.



- c. Retighten all of the bolts holding the blades onto the Dura-Reel.

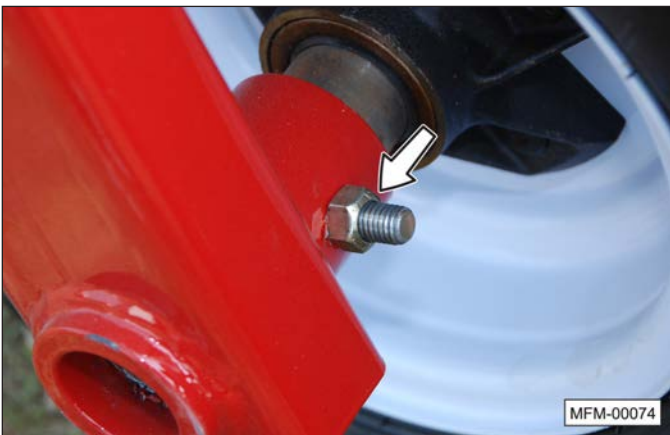

Wheel retainer bolts.



Hinge pin and hitch pin retainer bolts.

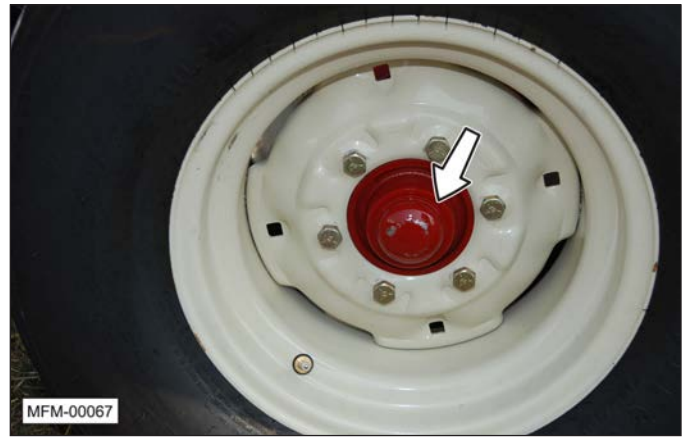

2. Prior to each use, visually check for loose or missing bolts and replace lost or worn parts.
3. Refer to the Lubrication Location Drawing on page 37 for a list of lubrication locations and frequency.

5. Refer to the parts illustrations and listings for service and repair parts.
6. Dura-Reel bearings should be lubricated annually.

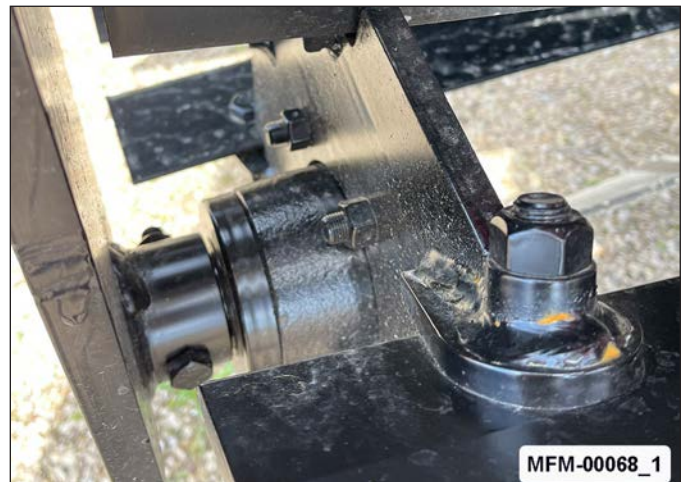

Note: Clean grease fittings and replace those that are broken or missing.

7. Inspect the rubber bumper pads on the wing support arms. Replace the pads if they are worn or missing.

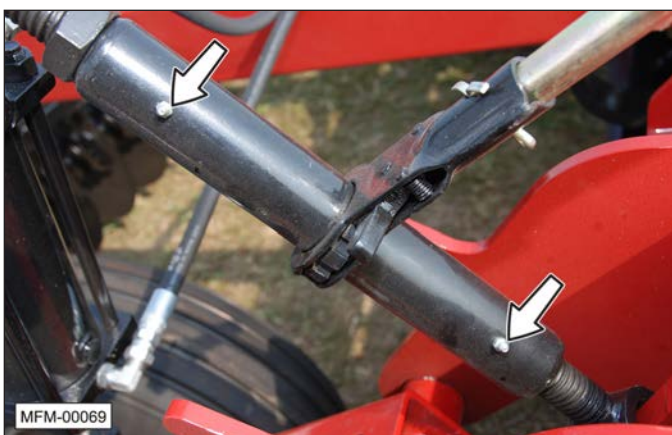

Note: Clean grease fittings and replace those that are broken or missing.

4. Clean, repack, and adjust the wheel bearings annually. Use only wheel bearing grease when repacking these units. Check for excessive end play. To adjust wheel bearing, remove dust cap and cotter pin. Lift tire and slowly rotate while tightening the spindle nut. Tighten only until a slight drag is felt on the rotating wheel. Re-install cotter pin and dust cap.

Maintenance Procedures

Wheel Lift Cylinders and Wing Cylinders

There are no setup procedures or maintenance items on these cylinders.

Disk Gang Disk Blades

1. Replace the disk blades when the diameter is 19 inches or less.
2. It will also be necessary to check and tighten the disk gang arbor nuts to prevent excessive wear.
3. After 12 hours initial operation, using a torque-multiplier, tighten the gang arbor nuts to 1200-1600 ft-lb.

Note: A torque of 1200-1600 ft-lb would be equivalent to a 200 pound person using a 6 to 8 foot wrench.

Note: When reassembling the disk gang, it may be necessary to add a 1-3/4" machine washer (10656) in order to align the cross-drilled hole in the shaft with the slots in the castle nut.

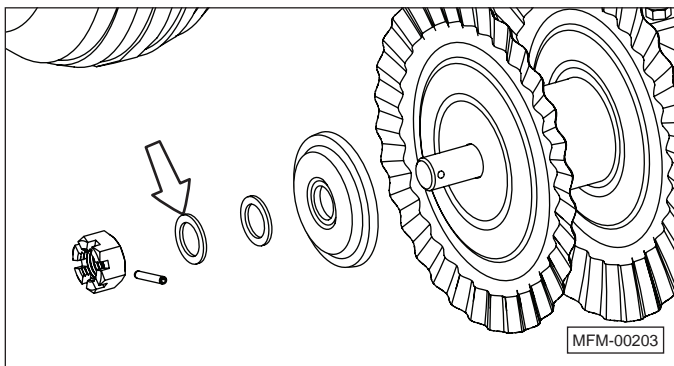

For Spur-Till finishing configuration

1. Regularly inspect Spur-Till tines for damage and replace or repair as needed.
2. It will also be necessary to check and tighten the Spur-Till gang arbor nuts to prevent excessive wear.
3. After 12 hours of initial operation, using a torque-multiplier, tighten the gang arbor nuts to 800-1000 ft-lb.

Note: when disassembling Spur-Till gangs, note the orientation of all Spur-Till wheels (left vs. right), bearings, spacers and fasteners.

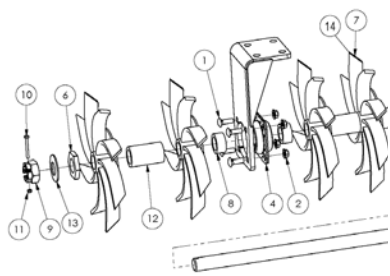

Removal of Dura-Reel Hub

1. Support the reel assembly.
2. Remove one reel blade.
3. Remove five hub bolts.
4. Remove hub cross bolt.
5. Slide hub free from reel.

Note: May need to loosen all bolts to reassemble.

Assembly and Lubrication Instructions for Dura-Reel Hub Assembly (RD-4854)



1. Tighten RD-4862 Hex Slotted Nut to 40 ft.-Lbs. Loosen nut to first slot in nut. Rotate hub five revolutions. If rotation is tight back off an additional slot.
2. Push RD-4863 Spring Pin through nut and spindle until it is flush with the nut.
3. Apply grease through the zerk until grease emerges through bearing rollers. Rotate hub five times.
4. Press RD-4859 Dust Cap onto hub.
5. Check end play.
 - a. Hold spindle securely in place.
 - b. Place a dial indicator onto the hub to measurement upward movement.
 - c. Use a bar or lifting device the raise hub upwards.
 - d. The reading should not exceed 0.002". Repair or replace hubs with excessive end play.

Lubrication Locations Drawing

Add grease to the locations shown in the photo on the following page.

When greasing a pin and bushing, add grease until it is visibly forced out of the joint.

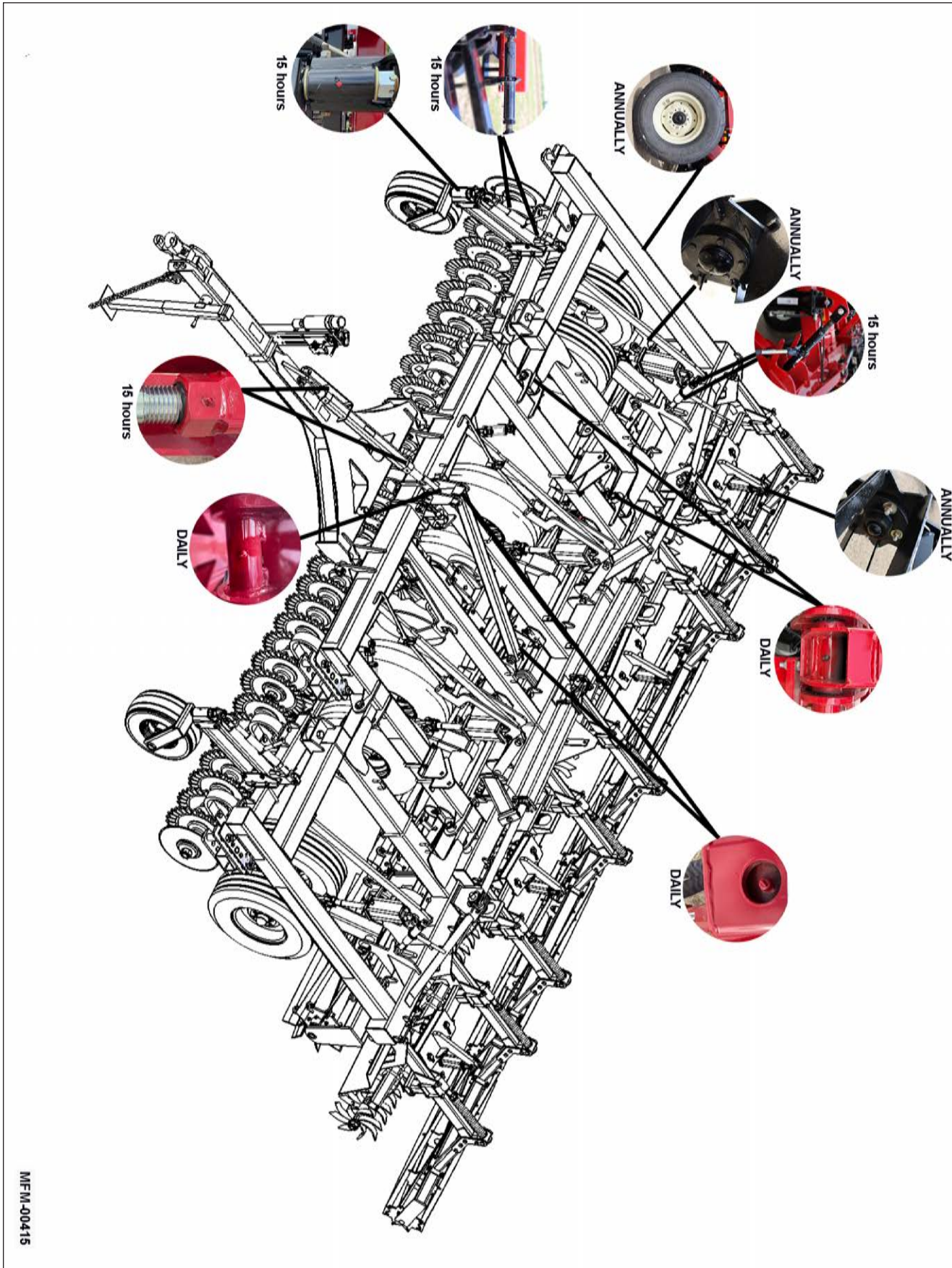

Hydraulic Component Safety

WARNING



Trapped Air Hazard

When installing, replacing, or repairing hydraulic system cylinders or parts, make sure that the entire system is charged and free of air before resuming operations. Failure to bleed the system of all air can result in improper machine operation, causing severe injury.



Zero Pressure

Relieve pressure from the hydraulic system before servicing or disconnecting from the tractor.



High-Pressure Fluid Hazard

Keep all hydraulic lines, fittings, and couplers tightly secured and free of leaks.



Explosive Separation Hazard

Replace any worn, cut, abraded, flattened, or crimped hoses.



High-Pressure Hazard

Do not make any temporary repairs to the hydraulic lines, fittings, or hoses using tape, clamps, or cement. The hydraulic system operates under extremely high pressure and temporary repairs may fail suddenly and create a hazardous/dangerous situation.



Personal Protection Equipment

Wear proper hand and eye protection when searching for a high-pressure hydraulic leak. Use a piece of wood or cardboard as a backstop instead of hands to identify and isolate a leak. If injured by a concentrated high-pressure stream of hydraulic fluid, seek medical attention immediately. Serious infection or toxic reaction can develop if hydraulic fluid penetrates the surface of the skin.



High-Pressure Fluid Hazard

Before applying pressure to the system, make sure all components are tight and that the hydraulic lines, hoses, and couplings are not damaged.

NOTICE

Make sure components in the hydraulic system are kept clean and in good working condition.

Tire Safety

WARNING



Explosive Separation Hazard

Do not attempt to mount tires unless you have the proper equipment and experience to do the job. Failure to follow proper procedures when mounting a tire on a wheel or rim can produce an explosive separation, which may result in serious injury or death.



Explosive Hazard

Never weld or heat a wheel and tire assembly. The heat can cause an increase in air pressure, resulting in a tire explosion. Welding can structurally weaken or deform the wheel.



Flying Objects Hazard

Inflating or servicing tires can be dangerous. Whenever possible, trained personnel should be called to service and/or mount tires.

When inflating tires, use a clip-on chuck and extension hose. Always stand to the side of the tire when inflating, and NOT in front of or over the tire assembly.

Make sure the tires are inflated evenly.



Crush Hazard

Make sure the unit is completely supported with suitable stands before removing a wheel assembly.

SAFETY INSTRUCTIONS



Always maintain the correct tire pressure. Do not inflate the tires above the recommended pressure.



Check tires for low pressure, cuts, bubbles, damaged rims, or missing lug bolts and nuts.



Always install tires and wheels with appropriate capacity to meet or exceed the weight of the unit.



Do not exceed 20 mph or tire failure will occur.



Keep wheel lug nuts or bolts tightened.

Dura-Reel Blades

To replace a Dura-Reel blade:

1. Remove the bolts that secure the blade to the center plate.
2. Install a new blade with 5/8-11 x 2-1/4" bolts and lock nuts. Tighten the nut 160 ft.lbs. (215 N·m).



Note: Make sure the blades are positioned with the beveled edge of the blade closest to the tab on the center plate, as shown in the photo. Install the bolts from the blade side.

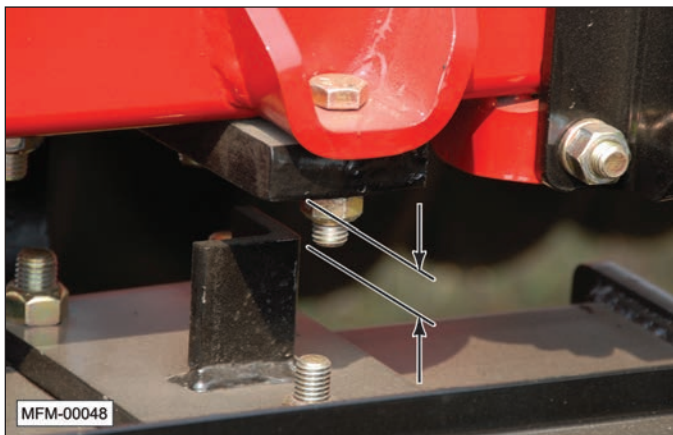

NOTICE

Make sure the stop plate is not in constant contact with the C-spring during normal operation. Reduce the depth setting of the Dura-Reel to reduce the constant contact.

Axle Assembly Wear Sleeves



No maintenance is required on the four axle mounting bearings. Check for excessive wear annually. To replace the bearings:

1. Support the main frame.
2. Support the wheel assembly and wheel lift cylinders to relieve the pressure on the bearings.
3. Remove the bearing retainer caps (center bearings) and end caps (outer bearings).
4. Insert four new bearing wear sleeves. Do not replace just one sleeve.
5. Reinstall the retainers and caps.

Storage

Safety

SAFETY INSTRUCTIONS

Follow all operating and safety instructions found in this manual when storing this equipment.



Store the unit in an area away from human activity.



Do not permit children to play on or around the stored unit at any time.

Make sure the unit is stored in an area with a firm and level base to prevent it from tipping or sinking into the ground.



Block the wheels to prevent the unit from rolling.

Power wash the unit prior to storage, following this protocol:

1. Washing equipment: It is very important to read the instruction manual and test the machine on a small spot

before starting the actual job. The scouring action of a pressure washer is very strong and may damage paint, and other surfaces if not properly used.

2. Nozzle Selection: Wide-fan nozzles are often preferred when pressure washing painted surfaces. Yellow (15-degree) or green (25-degree) fan nozzles are most common, white (40-degree) nozzles can also be used to clean unit.

3. Pressure Adjustment: To wash away dust and dirt, keep the pressure level between 1500 psi and 2000 psi. Pressures exceeding 2000 psi may damage paint depending on nozzle size and how close nozzle is to the part.

4. Wand angle: To avoid damaging painted surfaces, keep the wand angle/nozzle at a 45-degree angle and spray from a minimum distance of 12 inches. If you increase the pressure, move the nozzle further away from the surface.

5. Scrub away persistent dirt: Use a rotating scrub brush or a sponge along with a mild detergent solution to remove stubborn stains.

Placing Into Storage (Disk Coatings)

Apply a thin layer of grease to all exposed metal surfaces of the disks, reel, and reels blades. Disposal of Equipment at End of Useful Life

The McFarlane Cobra has been designed for the specific purpose of tilling agricultural farm land. When this unit is no longer capable of doing its designed purpose, it should be dismantled and scrapped. Do not use any materials or components from this unit for any other purpose.

Warranty

Limited Warranty Statement

FULL ONE YEAR WARRANTY

If within one year from the date of purchase, this Cobra fails due to a defect in material or workmanship, McFarlane Mfg. Co., Inc. will repair it, free of charge.

Warranty service is available at dealer locations by simply contacting the nearest McFarlane dealership throughout the United States or Canada.

This warranty applies only while this product is used in the United States or Canada.

This warranty gives you specific legal rights, and you may have other rights which vary from state-to-state.

Serial Number Location



Troubleshooting

Problem	Cause	Solution
Disk gang is not tilling to desired depth or the soil is not fully worked to desired depth.	Disk gang is not set deep enough.	Increase the depth of the disk gang up to a 4 inch maximum depth. Whenever you are making a change to any setting, make sure the unit remains level as it is pulled through the field.
	Disk gang angle is not set properly for the soil conditions.	Increase disk gang angle to loosen more soil.
Unit bounces or leaves surface uneven in loose soil.	Disk gang depth is set higher than the Dura-Reel depth.	Decrease depth of the spiral reels by carrying some of the weight on the wheels. The disk gang can then be lowered using the hitch turnbuckle to the desired depth of soil tilling.
The residue is not being turned into the ground.	The front gang disk is not set at an aggressive enough angle.	Increase the angle of the front disk gang.
	The front gang disk is not set deep enough.	Increase the depth of the disk gang up to a 4 inch maximum depth. Whenever you are making a change to any setting, make sure the unit remains level as it is pulled through the field.
	Travel speed is too slow.	Increase travel speed to 8 to 9 mph.
The residue is not being sized correctly.	The front disk gang may not be set deep enough.	Increase the depth of the disk gang up to a 4 inch maximum depth. Whenever you are making a change to any setting, make sure the unit remains level as it is pulled through the field.
Ridging is occurring within a pass.	Front disk gang is not set correctly.	Reduce the disk gang depth. Set the angle of the disk to be less aggressive.
	The center disk angles are set incorrectly.	Increase or decrease the angle of the outboard center disks to eliminate the ridging.
Disk gang ridges between adjacent passes.	The disk gang or wing frame are not set up properly.	Level the wing frame using the turnbuckles on the wing wheels to raise the outside of the disk gang.
		Reduce travel speed.
		Reduce angle of disks in disk gangs.
Center frame section not working to desired depth.	Wing frame is set too deep.	Raise the wing frame using the turnbuckles on the wing wheels to prevent the wings from working deeper than the center section.
Outside disk gang gouges.	Wing frame are not level.	Level the wing frame using the turnbuckles on the wing wheels to raise the outside of the disk gang or add gauge wheels.

Problem	Cause	Solution
Dura-Reel plugs in wet soil conditions.	Dura-Reel is set too deep.	Decrease the depth of the spiral reels by carrying some of the weight on the wheels. Increase speed.
Residue buildup on harrow bars.	Front disk gang is not set correctly.	Set the disk gang to a more aggressive angle in order to size the residue into smaller pieces.
	The harrow angle is not set correctly.	Change the angle of the teeth. Using the linkage settings that produce the flattest angle on the harrow is recommended. Setting the harrow to the steepest angle is usually recommended for spring work or light residue.
	The ground speed is too low.	Increase ground speed to 8 to 9 mph.
Rolling basket springs are breaking.	Too much spring tension.	Too much spring tension per section in this manual.
Spur-Till is plugging with mud	Spur-Till is set too deep	Reduce pressure (less depth) or lift it out of the ground

Parts Section

Ordering Parts

We manufacture a quality product that requires very little maintenance or repair. However, should a part break or become damaged, our knowledgeable staff can make sure you receive the part(s) to put your unit back into operation.

Dealer Contact Information

For replacement decals, questions, or to order parts, contact your dealer:

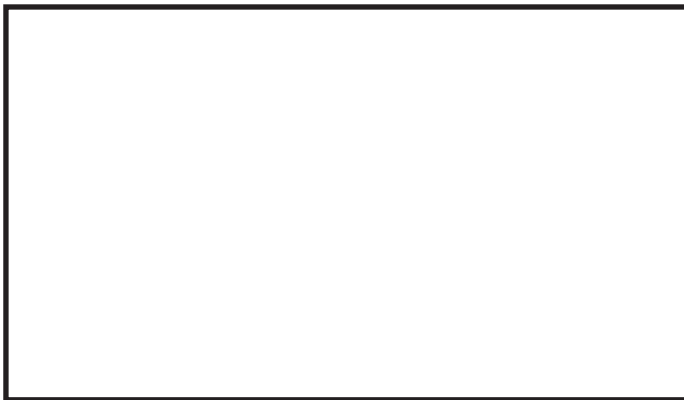

Decals



Make sure all decals are attached to the unit and are legible at all times. Safety decals and reflective tape provide a vital role in helping to reduce injuries and/or possibly even death.

To ensure the greatest level of safety, all decals must be in place and legible at all times. Remember, it is the user's responsibility to maintain these decals.

Parts Drawings

Hitch Frame for CB-4200 Series

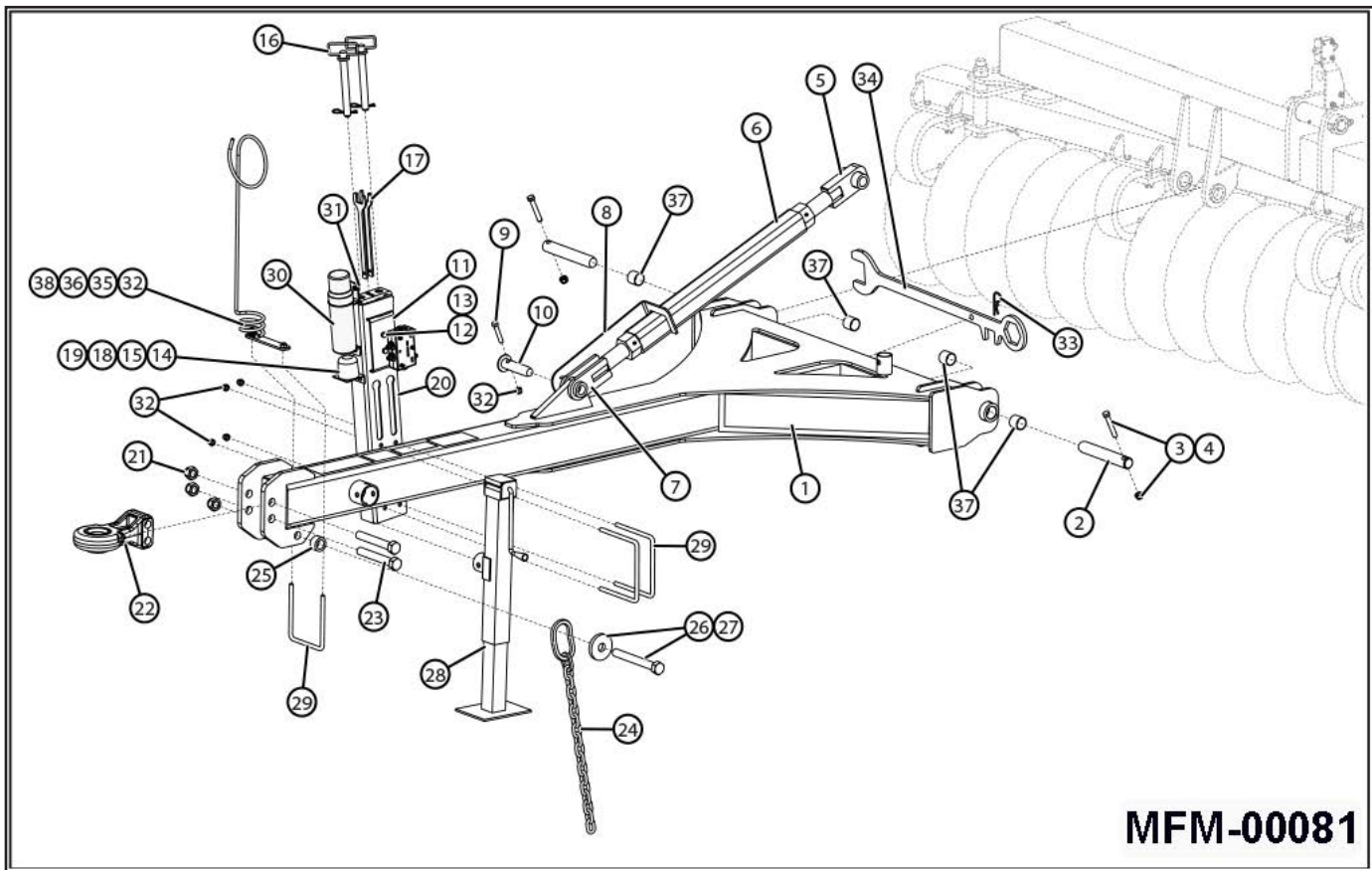

Item	Part Number	Description
1	15207	HITCH, 4212-4214
	15163	HITCH, 4220-4230
	15209	HITCH, 4235-4245
2	RT-2107	HINGE PIN, 1-1/2 X 9-5/8
3	BHY-5635	9/16-12 X 3-1/2 GRADE 8 BOLT
4	NLT-5612	9/16-12 TOP LOCK NUT
5	RT-2112	PIVOT END TURNBUCKLE, 3 7/8" DOM
6	RT-3145	HITCH TURNBUCKLE - 30"
7	RT-2111	HITCH END TURNBUCKLE, 2 EAR
8	RT-2114	TURNBUCKLE LOCK, 3"
9	BH-5028	1/2 X 2-3/4 GRADE 5 HEX BOLT
10	RT-2113	TURNBUCKLE PIN - 1-1/4 X 5-1/4
11	RD-4309	HYDRAULIC HOSE RACK CLAMP
12	BH-4420	7/16 X 2 HEX BOLT
13	NLT-4414	7/16 TOP LOCK NUT
14	LW-0025	1/4 LOCK WASHER
15	NH-2520	1/4 HEX NUT
16	PH-8860	HITCH PIN, 7/8 x 6 w/#6 BRIDGE PIN
17	RT-2416	TURNBUCKLE WRENCH, 1-1/4"
18	LB-1110	LIGHT PLUG STORAGE
19	BH-2510	1/4 X 1 HEX BOLT
20	10294	BRACKET, STORAGE, HITCH
21	NLT-1008	1" TOP LOCK NUT

Item	Part Number	Description
22	PPI-300	HITCH BASE CAT III (4212-4220)
	12336	PINTLE, ARTICULATING BALL CAT IV (4225-4245)
23	BHY-1070	1 X 7 GRADE 8 HEX BOLT
24	CH-1816	SAFETY CHAIN 16,100 lbs 4212-4220
	CH-1820	SAFETY CHAIN 20,200 lbs, 4225-4230
	CH-1830	SAFETY CHAIN 30,400 lbs, 4235-4245
25	RT-2054	BUSHING, 1 7/8" OD X 1-1/4" ID X 1"
26	RT-3103	WASHER, SAFETY CHAIN
27	BHY-1085	1 X 8-1/2 GRADE 8 HEX BOLT
28	RT-3144	JACK, SQ-15", 2000#
29	BU-1267	1/2 X 6 X 7-1/4 U-BOLT
30	14493	MANUAL STORAGE TUBE
31	FW-0025	WASHER, FLAT, 1/4
32	RT-2124	LEVEL LIFT TUBE PIN
33	NLT-5013	NUT, LOCK, HEX, 1/2-13

Hitch for CB-4212, CB-4214 and CB-4220 (CAT. III)

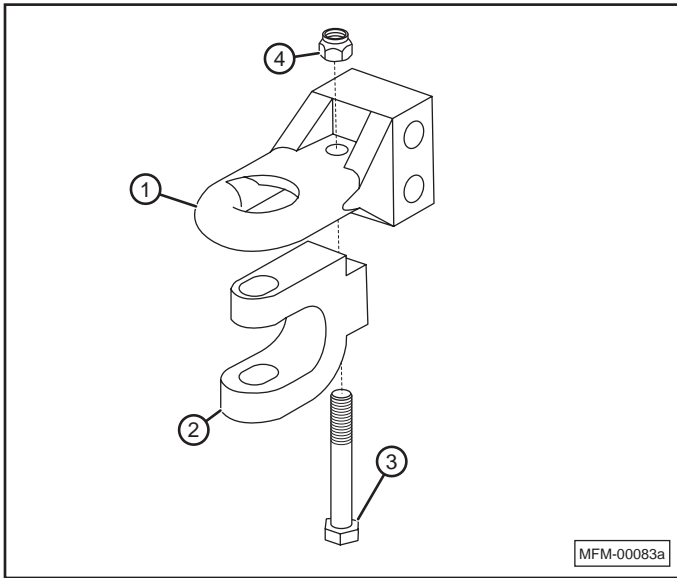

Wing Locks for CB-4220, 4225, 4230, 4235, 4245

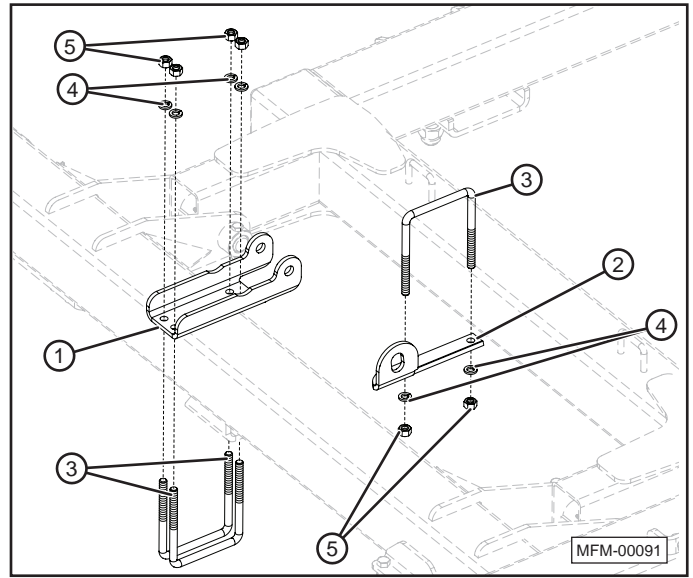

Hitch for CB-4225, CB-4230, CB-4235, CB-4245 (CAT. IV)

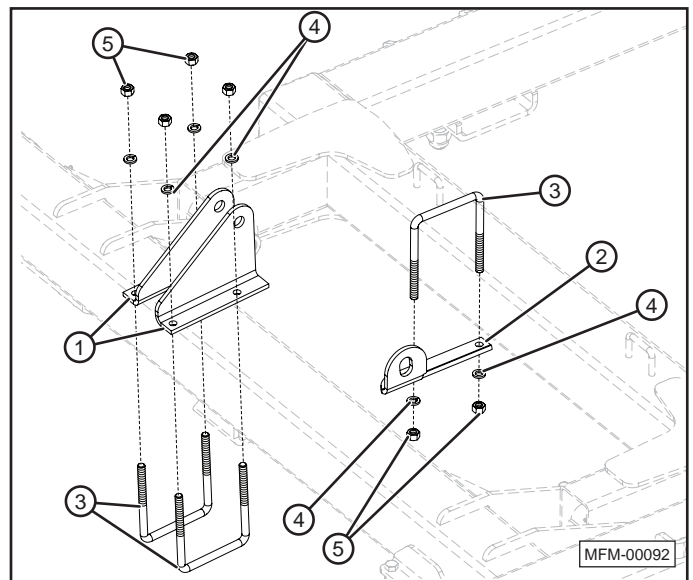
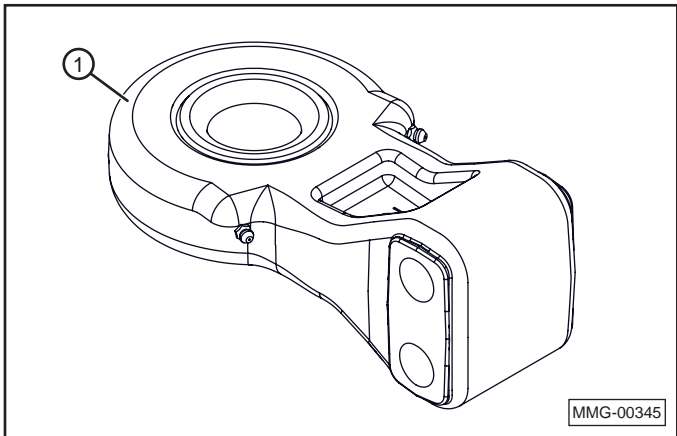

Item	Part Number	Description
1	PPI-300 12336	HITCH BASE, CAT. III PINTLE, ARTICULATING BALL CAT IV
2	PPI-208	CLEVIS, HITCH (CAT. III only)
3	BHY-7555	BOLT, HEX 3/4 X 5-1/2 GRADE 8 (CAT. III only)
4	NLT-7510	NUT, TOP LOCK, 3/4 (CAT. III only)

Item	Part Number	Description
1	RD-4508 RD-4509 RD-4610 RD-4611	MAIN FRAME WING LOCK, LEFT (4120) MAIN FRAME WING LOCK, RIGHT (4120) MAIN FRAME WING LOCK (4125, 4130, 4135) MAIN FRAME WING LOCK (4145)
2	RD-4612	WING FRAME WING LOCK (ALL SIZES)
3	BU-5867	5/8-11 X 6 X 7-1/2 U-BOLT
4	LW-0063	5/8 LOCK WASHER
5	NH-6311	5/8-11 HEX NUT

Gauge Wheel Frame for CB-4200 Series

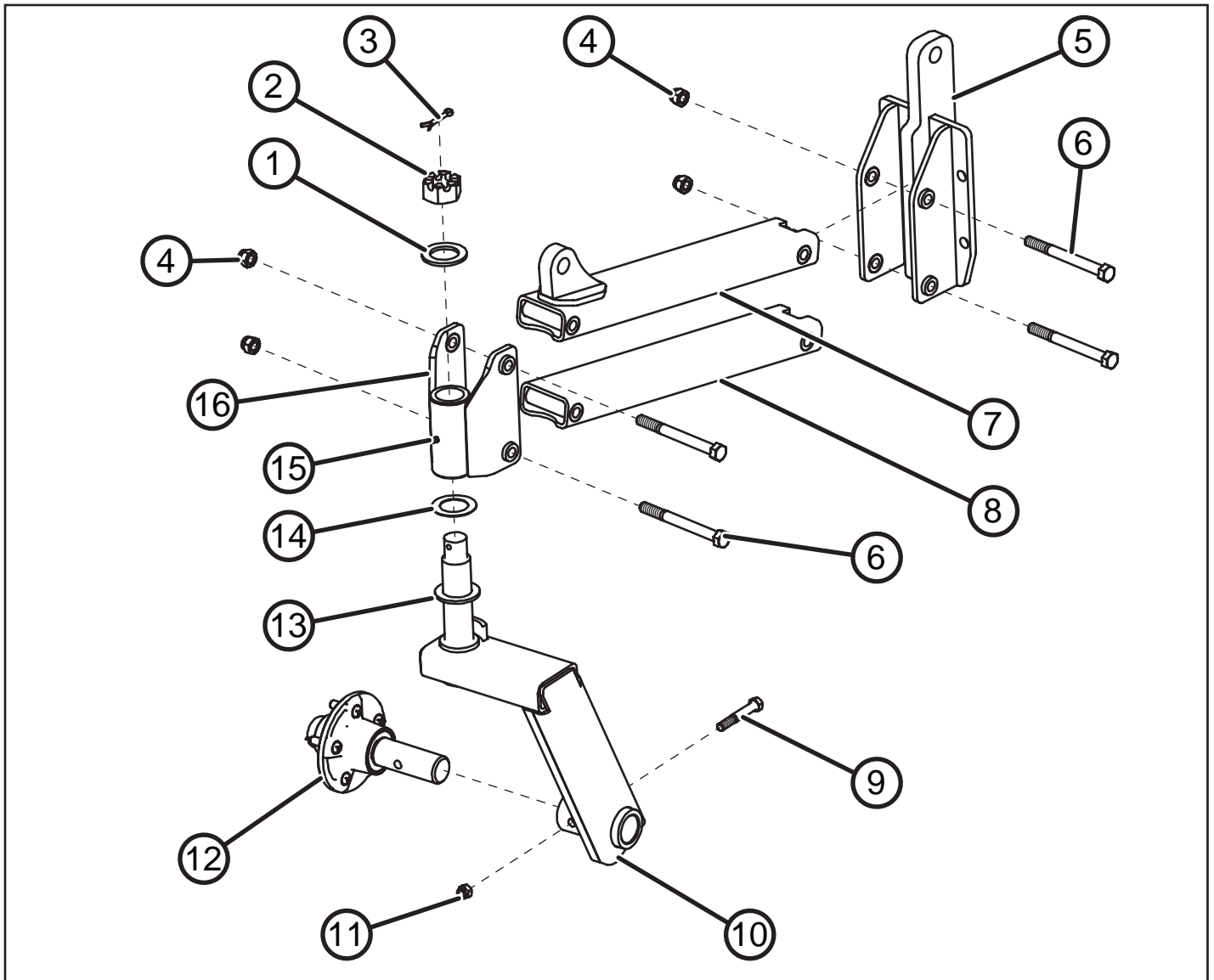

Item	Part Number	Description
1	RD-4876	CASTER WASHER
2	NC-1406	1-3/8 CASTLE NUT
3	CP-3620	COTTER PIN
4	NLT-6311	5/8-11 TOP LOCK NUT
5	RD-4870	CASTER TO GANG MOUNT
6	BH-6365	5/8-11 x 6-1/2 HHCS GD 5
7	RD-4869	TOP LINK
8	RD-4873	BOTTOM LINK

Item	Part Number	Description
9	BH-5035	1/2-13 x 3-1/2 HHCS GD 5
10	RD-4872	CASTER ARM ASSY
11	NLT-5013	1/2-13 TOP LOCK NUT
12	RD-4877	HUB & SPINDLE
13	RD-4867	CASTER THRUST WASHER
14	RD-4876	CASTER WASHER
15	GZ-2528	GREASE FITTING
16	RD-4871	CASTER VERTICAL PIVOT

Gauge Wheel for CB-4200 Series

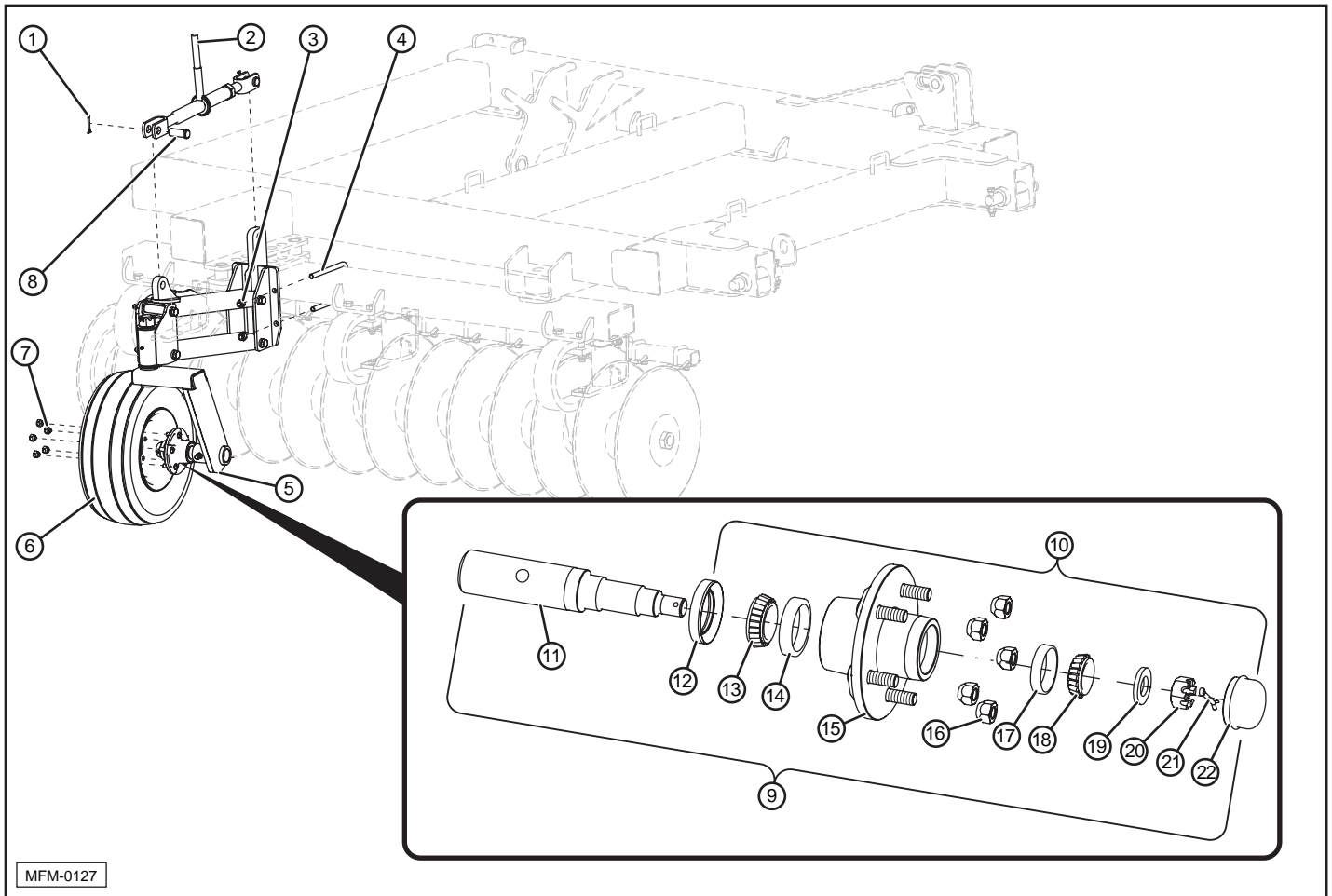

MFM-0127

Item	Part Number	Description
1	CP-3620	COTTER PIN
2	HYO-2008	RATCHET
3	NLT-6311	5/8-11 TOP LOCK NUT
4	BU-5848	U-BOLT
5	RD-4906	GAUGE WHEEL ASSY
6	20.5-8 10TR	TIRE WHEEL ASSY
7	WN-0050	LUG NUT
8	HD-1149	CYLINDER PIN
9	RD-4877	HUB & SPINDLE ASSY
10	RD-4881	HUB ASSY
11	RD-4883	SPINDLE

Item	Part Number	Description
12	RD-4880	HUB SEAL
13	RD-4884	INNER BEARING
14	RD-5114	INNER RACE
15	RD-4878	HUB W/ RACES
16	WN-0050	WHEEL NUT
17	HD-1182	OUTER RACE
18	RD-4879	OUTER BEARING
19	HD-1164	WASHER
20	HD-1165	CASTLE NUT
21	CP-3620	COTTER PIN
22	RD-4882	DUST CAP

Level Lift and Cylinder Lock for CB-4200 Series

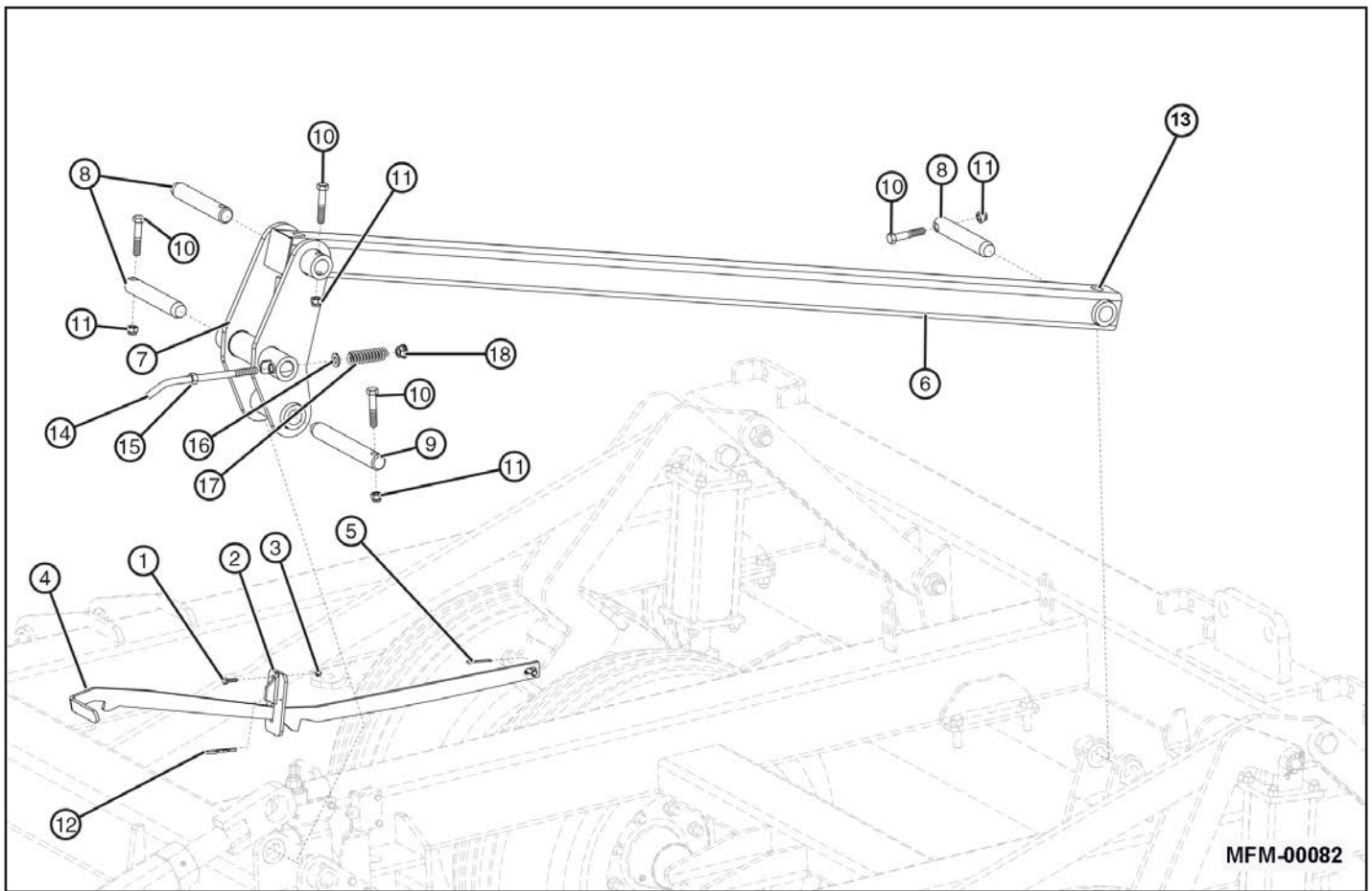

Item	Part Number	Description
1	BH-2510	1/4 - 20 X 1 GRADE 5 HEX BOLT
2	HYS-1104	CYLINDER LOCK HANDLE LOCK
3	NLT-2520	1/4 - 20 TOP LOCK NUT
4	HYS-1103	CYLINDER LOCK HANDLE
5	CP-1810	COTTER PIN, 1/8 X 1
6	RT-3109	LEVEL LIFT REAR TUBE
7	RD-4912	LEVEL LIFT PIVOT PLATE
8	RT-2124	LEVEL LIFT TUBE PIN, 1-1/4 X 7-1/2
9	RT-3107	PIVOT PLATE PIN, 1-1/4 X 9-1/2
10	BH-5028	1/2-13X 2-3/4 GRADE 5 HEX BOLT

Item	Part Number	Description
11	NLT-5013	1/2-13 TOP LOCK NUT
12	PB-0009	BRIDGE PIN #9
13	GZ-2528	GREASE FITTING, 1/4-28 STRAIGHT
14	RD-4914	HYDRAULIC STOP CRANK
15	NH-5020	1/2-20 NUT
16	RD-5060	LEVELER SPRING BASE
17	RD-4355	LEVELER SPRING
18	RD-5059	LEVELER SPRING END

Main Frame Axle for CB-4212, 4214, 4220, 4225 and 4230

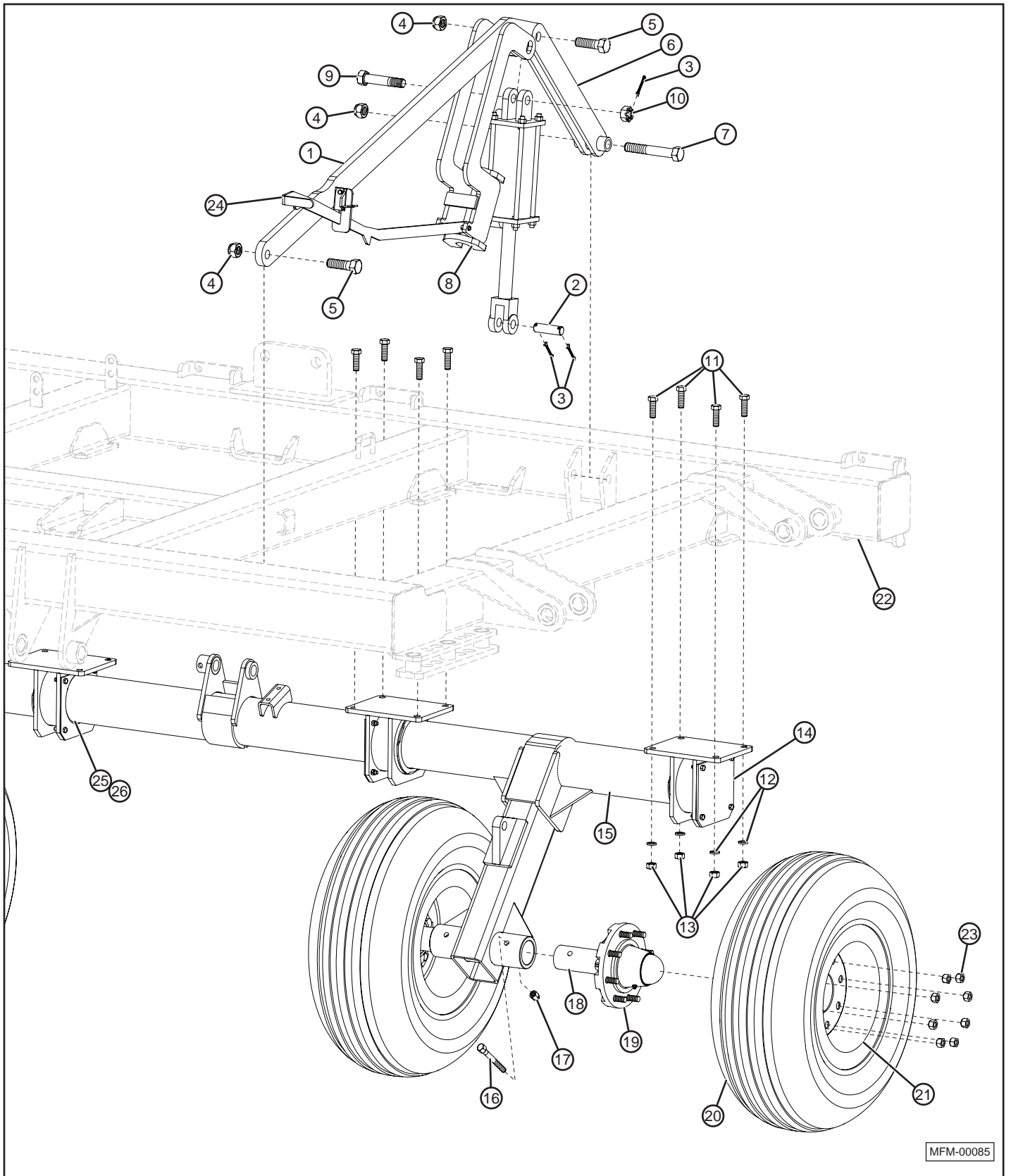

Main Frame Axle for CB-4212, 4214, 4220, 4225 and 4230 (continued)

Item	Part Number	Description
1	RD-4361	MAIN AXLE CYLINDER ARM
2	HYO-2103	CYLINDER CLEVIS PIN, 1 X 3
3	CP-3620	3/16 X 2 COTTER PIN
4	NLT-1008	1-8 TOP LOCK NUT
5	BHY-1033	1-8 X 3-1/4 GRADE 8 HEX BOLT
6	RD-4360	MAIN AXLE CYLINDER TRUSS
7	BHY-1065	1-8 X 6-1/2 GRADE 8 HEX BOLT
8	HYS-1102	CYLINDER LOCK, RD TRANSPORT
9	HYS-1112	1-8 X 5 GRADE 8 HEX BOLT W/PIN HOLE
10	NCJ-1008	1" CASTLE JAM NUT
11	BH-6320	5/8-11 X 2 GRADE 5 HEX BOLT
12	LW-0063	5/8 LOCK WASHER
13	NH-6311	5/8-11 HEX NUT
14	RD-4626 QT-1133 QT-1132	AXLE MOUNT BRACKET AXLE MOUNT INSERT AXLE MOUNT CAP
15	RD-5047 RD-5048 RD-4983 RD-5049 RD-5050	MAIN AXLE ASSEMBLY (4112) MAIN AXLE ASSEMBLY (4114) MAIN AXLE ASSEMBLY (4116) MAIN AXLE ASSEMBLY (4120) MAIN AXLE ASSEMBLY (4125-4130)
16	BH-5045	1/2" - 13 X 4-1/2 HEX BOLT
17	NLT-5013	1/2" - 13 TOP LOCK NUT
18	WDL-2505 RT-2170 RT-3180	SPINDLE, 1 3/4 X 9 1/2 (4112-4116) SPINDLE, 2 1/4 X 11 1/2 (4120) SPINDLE, 2 3/4 X 12 1/2 (4125-4130)
19 ¹	HD-1371 RT-2171 RT-3181	6 BOLT HUB ASSEMBLY, 3560 LB (4112-4116) 8 BOLT HUB ASSEMBLY, 4500 LB (4120) 8 BOLT HUB ASSEMBLY, 6000 LB (4125-4130)
20	12614 12616 12490 12615	ASM, TIRE/RIM, IF320/70R15 (4112-4116 and ALL WINGS) ASM, TIRE/RIM, IF320/70R15(4120-4135) TIRE ONLY, 11L – 15, 8 PLY (4112-4116 and ALL WINGS) TIRE ONLY, IF320/70R15 (4120-4135)
21	HD-1368 RT-2179	RIM, 15 X 8, 6-BOLT, 2900 LB (4112-4116) RIM, 15 X 10, 8 BOLT, 5000 LB (4120-4130)
22	RD-4587 RD-4588 RD-4646 RD-4589 RD-4590	MAIN FRAME (4112) MAIN FRAME (4114) MAIN FRAME (4116) MAIN FRAME (4120) MAIN FRAME (4125-4130)
23	WN-0063 WB-5010	WHEEL NUTS 5/8 WHEEL BOLT-1/2 x 1-3/4
24	HYS-1103	CYLINDER LOCK HANDLE
25	QT-1133	AXLE MOUNT INSERT
26	QT-1173	AXLE MOUNT INSERT, SPLIT

¹See hub diagram for details

Main Frame Axle for CB-4235 and 4245

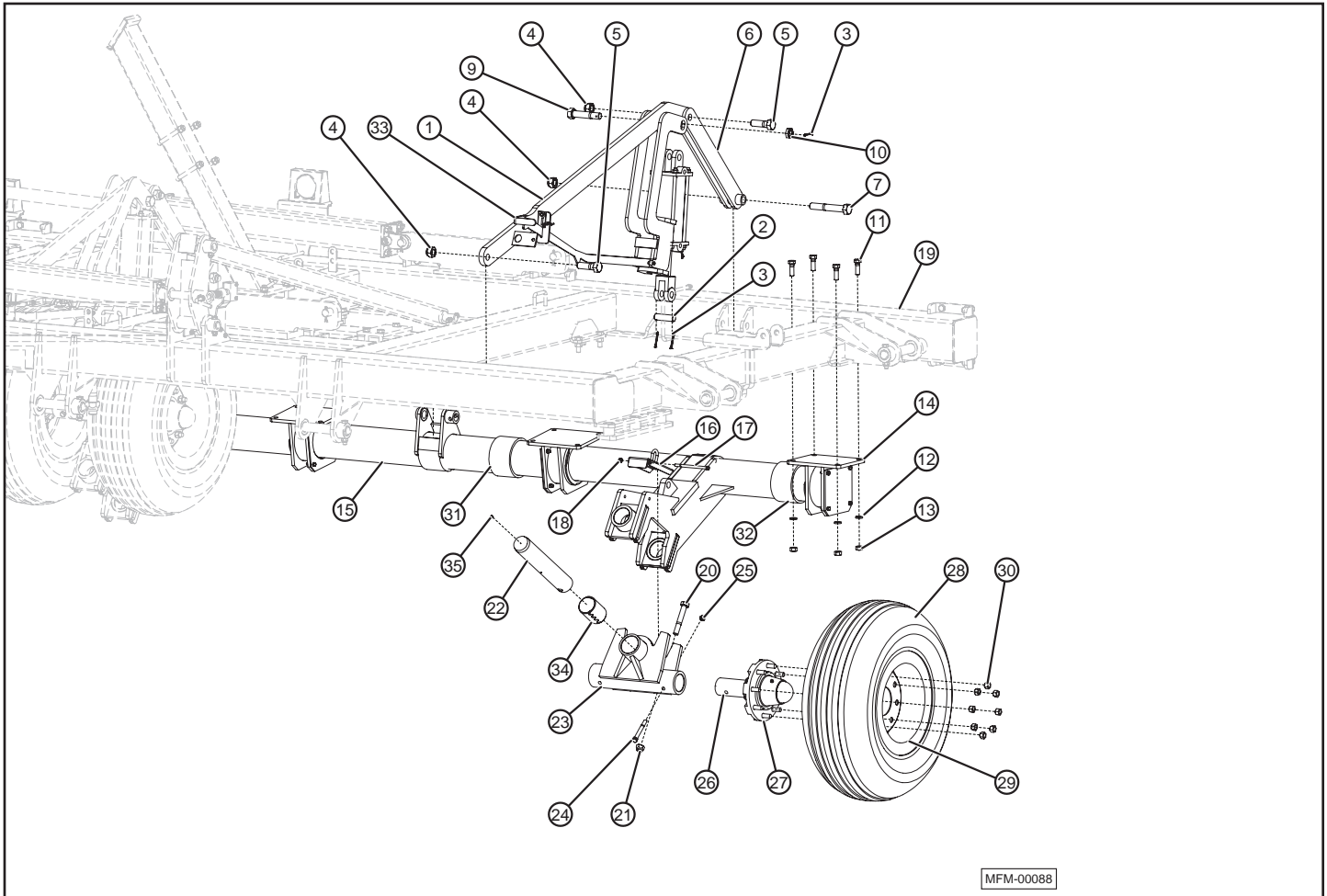

MFM-00088

Item	Part Number	Description
1	RD-4361 RD-4637	MAIN AXLE CYLINDER ARM (4135) MAIN AXLE CYLINDER ARM (4145)
2	HYO-2103	CYLINDER CLEVIS PIN, 1 X 3
3	CP-3620	3/16 X 2 COTTER PIN
4	NLT-1008	1-8 TOP LOCK NUT
5	BHY-1033	1-8 X 3-1/4 GRADE 8 HEX BOLT
6	RD-4360	MAIN AXLE CYLINDER TRUSS
7	BHY-1065	1-8 X 6-1/2 GRADE 8 HEX BOLT
8	HYS-1102	CYLINDER LOCK, RD TRANSPORT
9	HYS-1112	1-8 X 5 GRADE 8 HEX BOLT W/PIN HOLE
10	NCJ-1008	1" CASTLE JAM NUT
11	BH-6320	5/8-11 X 2 GRADE 5 HEX BOLT
12	LW-0063	5/8 LOCK WASHER
13	NH-6311	5/8-11 HEX NUT
14	RD-4626 QT-1133 QT-1132	AXLE MOUNT BRACKET AXLE MOUNT INSERT AXLE MOUNT CAP
15	RD-5051 RD-5053	MAIN AXLE ASSEMBLY (4135) MAIN AXLE ASSEMBLY (4145)
16	RD-4433 RD-4715	CARRIAGE COVER PLATE (4135) CARRIAGE COVER PLATE (4145)
17	BH-3860	3/8-16 X 6 GRADE 5 HEX BOLT

18	NLT-3816	3/8-16 TOP LOCK NUT
19	RD-4992 RD-4995	MAIN FRAME (4135) MAIN FRAME (4145)
20	BH-7550	3/4-10 X 5 GRADE 5 HEX BOLT
21	NLT-7510	3/4 TOP LOCK NUT
22	RD-4644	AXLE CARRIAGE PIVOT PIN
23	13094 RD-4642	AXLE CARRIAGE ASSEMBLY (4135) AXLE CARRIAGE ASSEMBLY (4145)
24	BH-5050	1/2-13 X 5 HEX BOLT
25	NLT-5013	1/2-13 TOP LOCK NUT
26	RD-4416	SPINDLE, 3 X 12-1/2
27	RD-4580	8 BOLT HUB ASSEMBLY, 7500 LB
28	12616 12615 - 36x16-17.5 14T	ASM,TIRE/RIM, IF320/70R15 (4135) TIRE, IF320/70R15 (4135) ASM,TIRE/RIM (4145) TIRE ONLY, 36x16-17.5 14T, 14 PLY (4145)
29	RT-2179 RD-4645	RIM, 15 X 10, 8 BOLT, 5000 LB (4135) RIM, 17.5 X 10.5, 8-BOLT, 8000 LB (4145)
30	WN-0063	WHEEL NUTS 5/8
31	QT-1173	AXLE MOUNT INSERT SPLIT
32	QT-1133	AXLE MOUNT INSERT
33	HYS-1103	LOCK HANDLE
34	RD-4643	SPRING BUSHING
35	GZ-2528	GREASE ZERK

Wing Rest for CB-4220

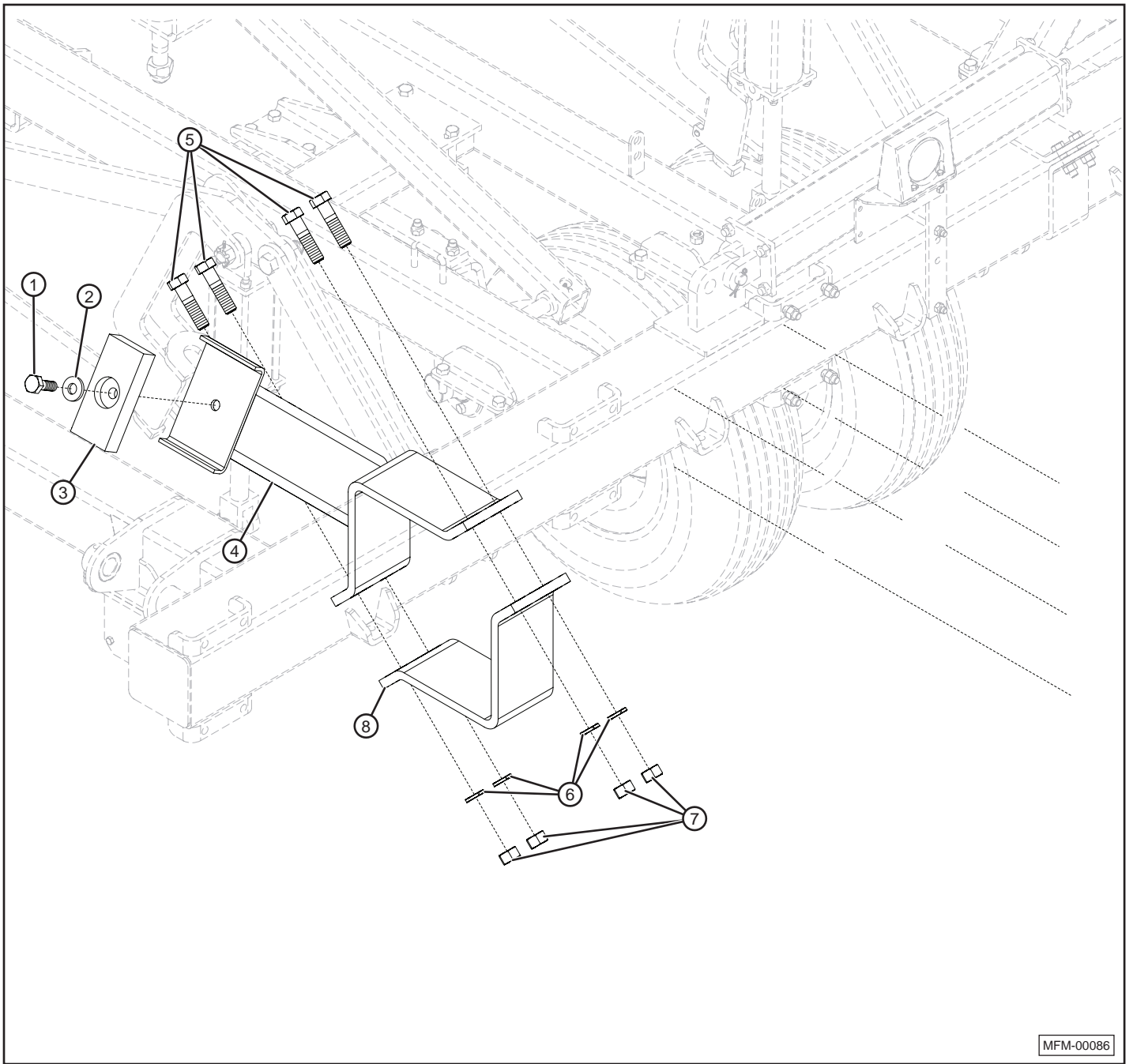

MFM-00086

Item	Part Number	Description
1	BH-5015	1/2 – 13 X 1-1/2 GRADE 5 HEX BOLT
2	FW-0050	WASHER, FLAT, 1/2
3	RT-3415	WING REST BUMPER
4	RD-4488 RD-4489	WING REST, LEFT HAND (SHOWN) WING REST, RIGHT HAND
5	BH-6325	5/8-11 X 2-1/2 GRADE 5 HEX BOLT
6	LW-0063	5/8 LOCK WASHER
7	NH-6311	5/8-11 HEX NUT
8	SPR-2752	WING REST CLAMP

Wing Rest for CB-4225, 4230 and 4235

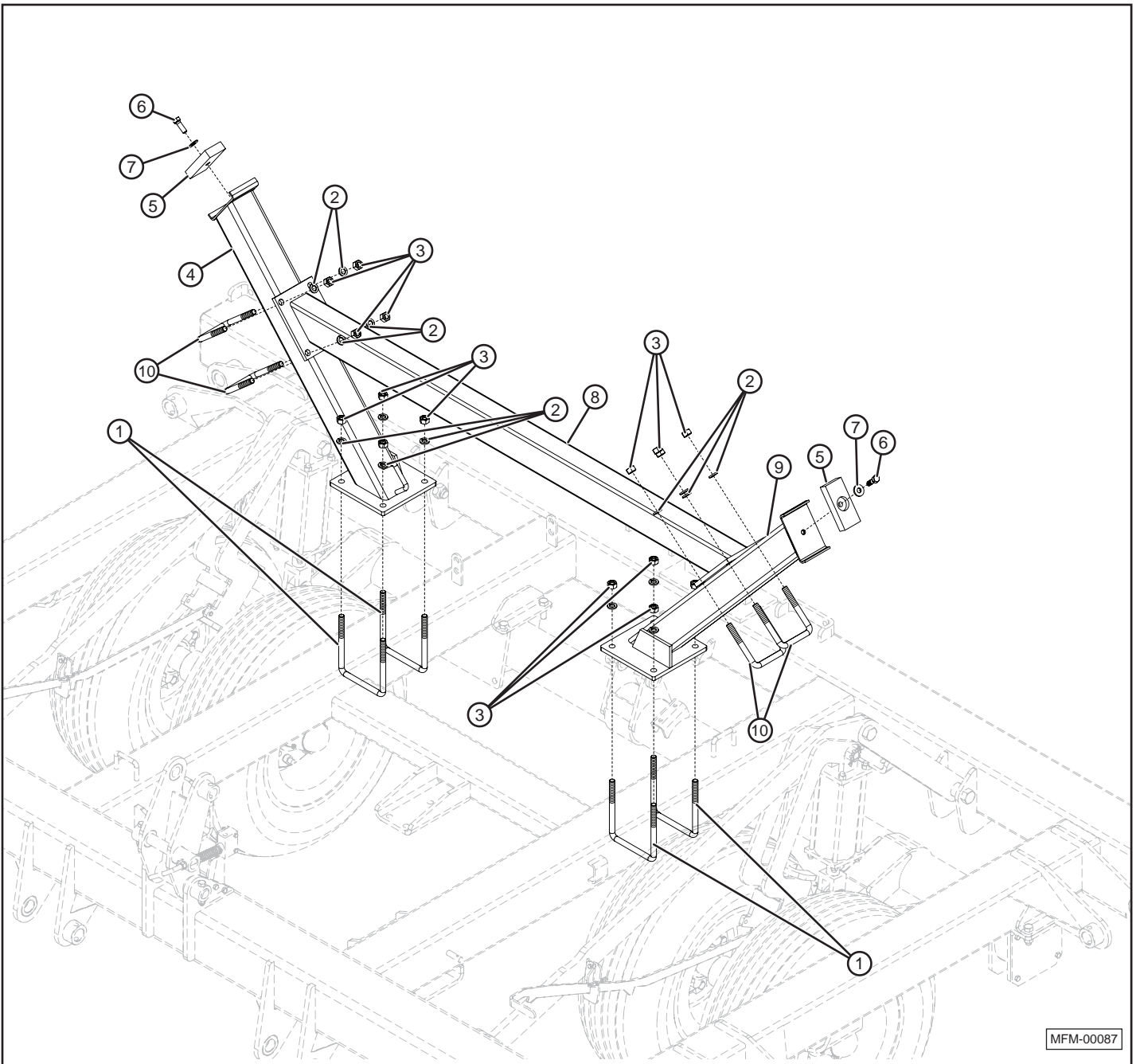

Item	Part Number	Description
1	BU-5867	5/8-11 X 6 X 7-1/2 U-BOLT
2	LW-0063	5/8 LOCK WASHER
3	NH-6311	5/8-11 HEX NUT
4	RD-4620 RT-3434 RD-4621	WING REST ASSEMBLY, RIGHT (4125) WING REST ASSEMBLY, RIGHT (4130) WING REST ASSEMBLY, RIGHT (4135)
5	RT-3415	WING REST BUMPER
6	BH-5015	1/2-13X 1-1/2 GRADE 5 HEX BOLT
7	FW-0050	WASHER, FLAT, 1/2

Item	Part Number	Description
8	RD-4483 RT-3433 RD-4487	WING REST BRACE (4125) WING REST BRACE (4130) WING REST BRACE (4135)
9	RD-4482 RT-3432 RD-4486	WING REST ASSEMBLY, LEFT (4125) WING REST ASSEMBLY, LEFT (4130) WING REST ASSEMBLY, LEFT (4135)
10	BU-5845	5/8-11 X 4 X 5-1/2 U-BOLT

Wing Rest for CB-4245

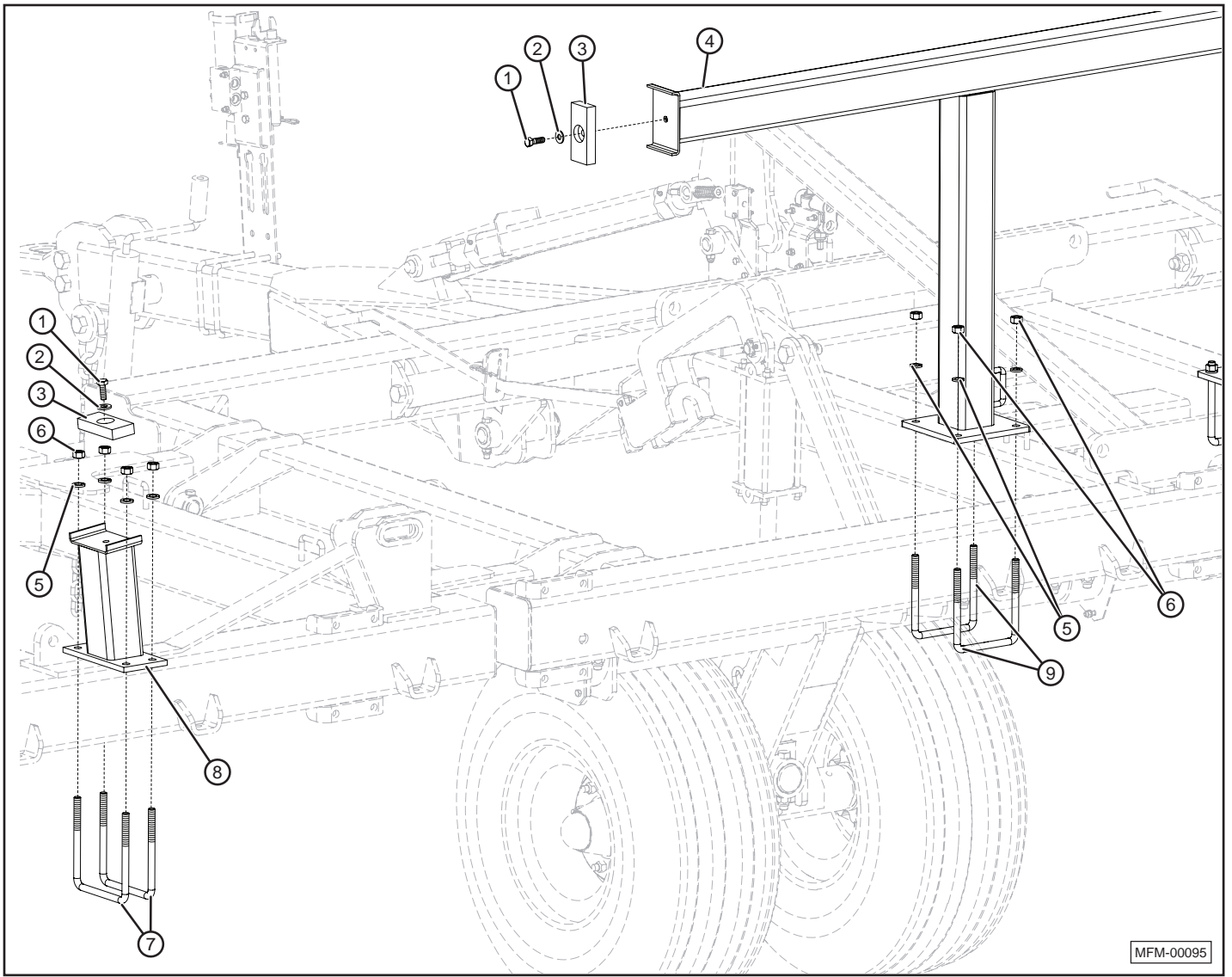

MFM-00095

Item	Part Number	Description
1	BH-5015	1/2-13 X 1-1/2 GRADE 5 HEX BOLT
2	FW-0050	WASHER, FLAT, 1/2
3	RT-3415	WING REST BUMPER
4	RD-4636	WING REST (4145)
5	LW-0063	5/8 LOCK WASHER
6	NH-6311	5/8-11 HEX NUT
7	BU-5879	5/8-11 X 7 X 8-1/2 U-BOLT
8	RD-4577	WING REST, OUTSIDE
9	BU-5867	5/8-11 X 6 X 7-1/2 U-BOLT

Wing Frame for CB-4220, 4225, 4230 and 4235

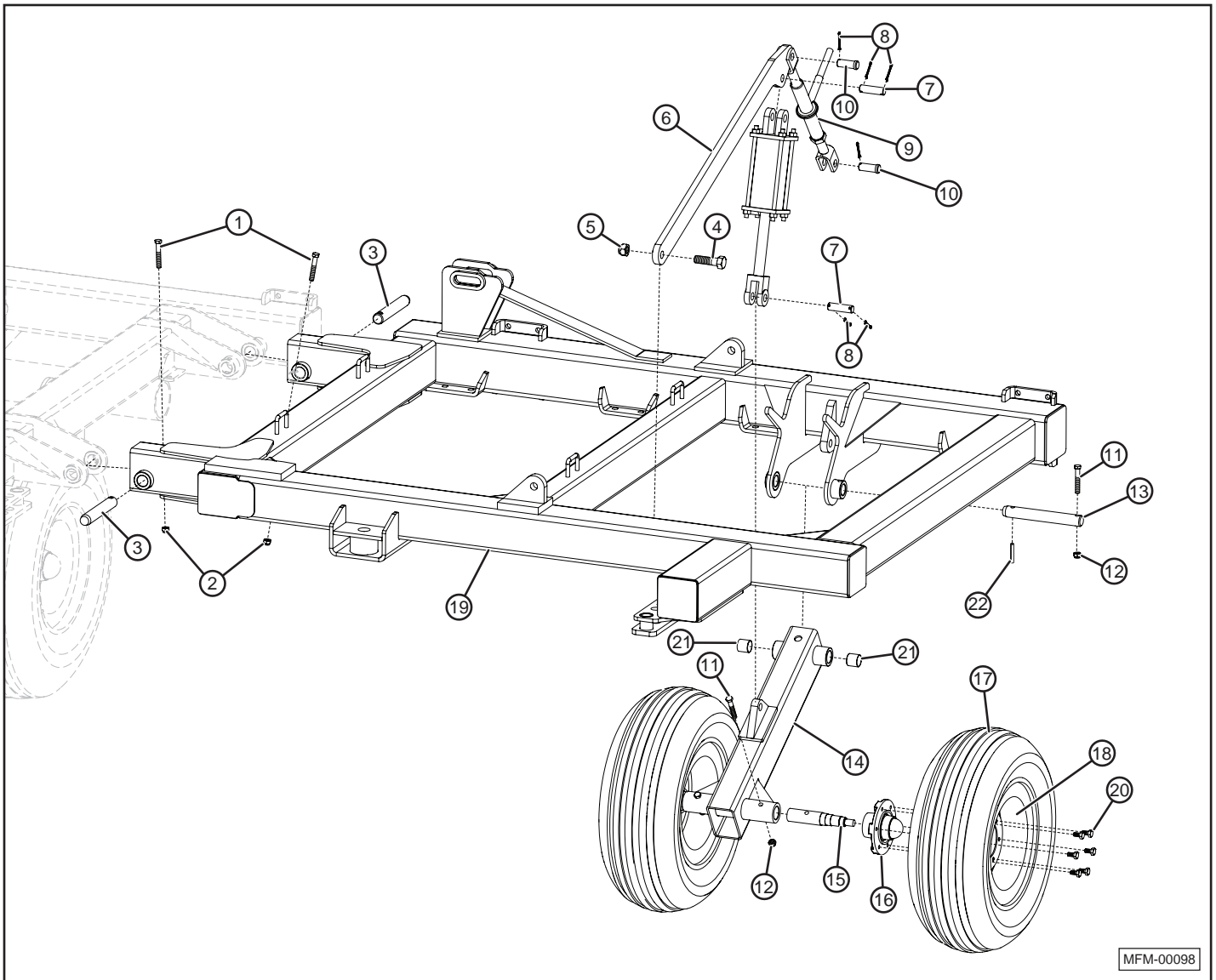

Item	Part Number	Description
1	BHY-5635	9/16-12 X 3-1/2 GRADE 8 BOLT
2	NLT-5612	9/16-12 TOP LOCK NUT
3	RT-2107	WING HINGE PIN, 1-1/2 X 9-5/8
4	BHY-1033	1-8 X 3-1/4 GRADE 8 HEX BOLT
5	NLT-1008	1-8 TOP LOCK NUT
6	RD-4624	WING AXLE CYLINDER ARM
7	HYO-2103	CYLINDER CLEVIS PIN, 1 X 3
8	CP-3620	3/16 X 2 COTTER PIN
9	HYO-2008	RATCHET JACK, 8" STROKE
10	HD-1149	1 X 2-1/2 CLEVIS PIN
11	BHY-5635	9/16-12 X 3-1/2 GRADE 8 BOLT
12	NLT-5612	9/16-12 TOP LOCK NUT
13	RD-5061	WING AXLE PIVOT PIN
14	RD-4888	WING AXLE ASSEMBLY, DUAL (all models)

Item	Part Number	Description
15	WDL-2505	SPINDLE, 1-3/4 X 9-1/2
16	HD-1371	6-HOLE HUB ASSEMBLY
17	12616	ASM, TIRE/RIM, IF320/70R15
	12615	TIRE ONLY, IF320/70R15
18	HD-1368	RIM, 15 X 8, 6-BOLT, 2900 LB
19	RD-4988	WING FRAME, LEFT (4120)
	RD-4989	WING FRAME, RIGHT (4120)
	RD-4990	WING FRAME, LEFT (4125)
	RD-4991	WING FRAME, RIGHT (4125)
	RD-4892	WING FRAME, LEFT (4130)
	RD-4893	WING FRAME, RIGHT (4130)
20	RD-4993	WING FRAME, LEFT (4135)
	RD-4994	WING FRAME, RIGHT (4135)
20	WB-5010	WHEEL BOLTS, 1/2-20 X 1-3/4
21	RD-4889	BUSHING
22	RD-5062	ROLL PIN, 1/2 X 2-1/2

Wing Frame, Inside for CB-4245

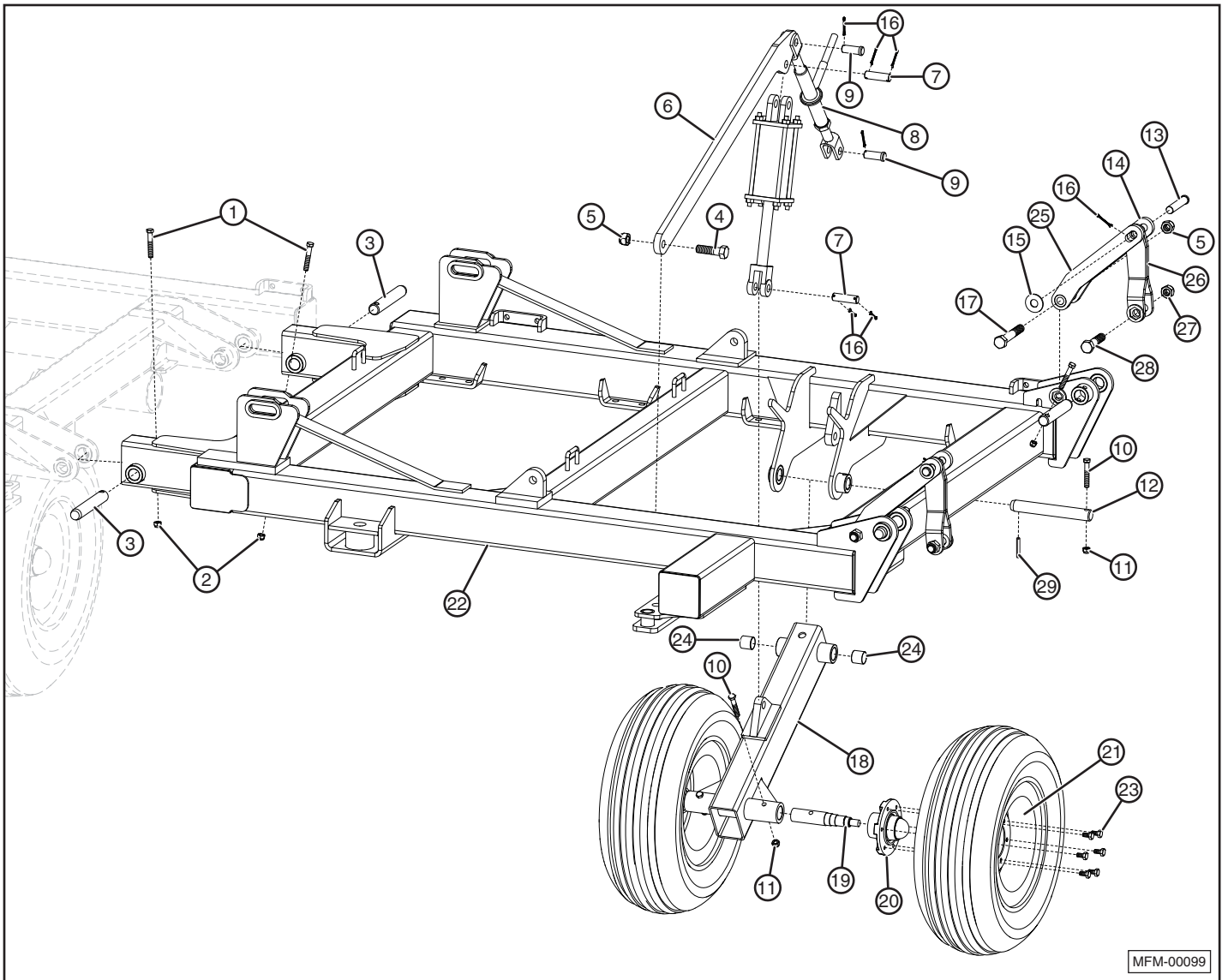

Item	Part Number	Description
1	BHY-5635	9/16-12 X 3-1/2 GRADE 8 BOLT
2	NLT-5612	9/16-12 TOP LOCK NUT
3	RT-2107	WING HINGE PIN, 1-1/2 X 9-5/8
4	BHY-1033	1-8 X 3-1/4 GRADE 8 HEX BOLT
5	NLT-1008	1-8 TOP LOCK NUT
6	RD-4624	WING AXLE CYLINDER ARM
7	HYO-2103	CYLINDER CLEVIS PIN, 1 X 3
8	HYO-2008	RATCHET JACK, 8" STROKE
9	HD-1149	1 X 2-1/2 CLEVIS PIN
10	BHY-5635	9/16-12 X 3-1/2 GRADE 8 BOLT
11	NLT-5612	9/16-12 TOP LOCK NUT
12	RD-5061	WING AXLE PIVOT PIN
13	CL-1005	PIN, CLEVIS, 1 X 5
14	RD-4423	WING LINKAGE ASSEMBLY
15	FWP-0100	1" PLAIN FLAT WASHER
16	CP-3620	3/16 X 2 COTTER PIN
17	BHY-1065	1-8 X 6-1/2 GRADE 8 HEX BOLT

Item	Part Number	Description
18	RD-4888	WING AXLE, DUAL
19	WDL-2505	WING AXLE SPINDLE
20	HD-1371	6-HOLE HUB ASSEMBLY
21	HD-1368	RIM, 15X8, 6 BOLT, 2900 LB.
	12614 12490	ASM, TIRE/RIM, IF320/70R15 TIRE ONLY, 11L - 15, 8 PLY
22	RD-4996 RD-4997	WING FRAME ASSEMBLY, LEFT INSIDE WING FRAME ASSEMBLY, RIGHT INSIDE
23	WB-5010	WHEEL BOLTS, 1/2-20 X 1-3/4
24	RD-4889	BUSHING
25	RD-4423	ARM
26	RD-4425	LEVER, LH
	RD-4426	LEVER, RH
27	NLT-1008	1-8 TOP LOCK NUT
28	BHY-1065	1-8 X 6-1/2 GRADE 8 HEX BOLT
29	RD-5062	ROLL PIN, 1/2 X 2-1/2

Wing Frame, Outside for CB-4245

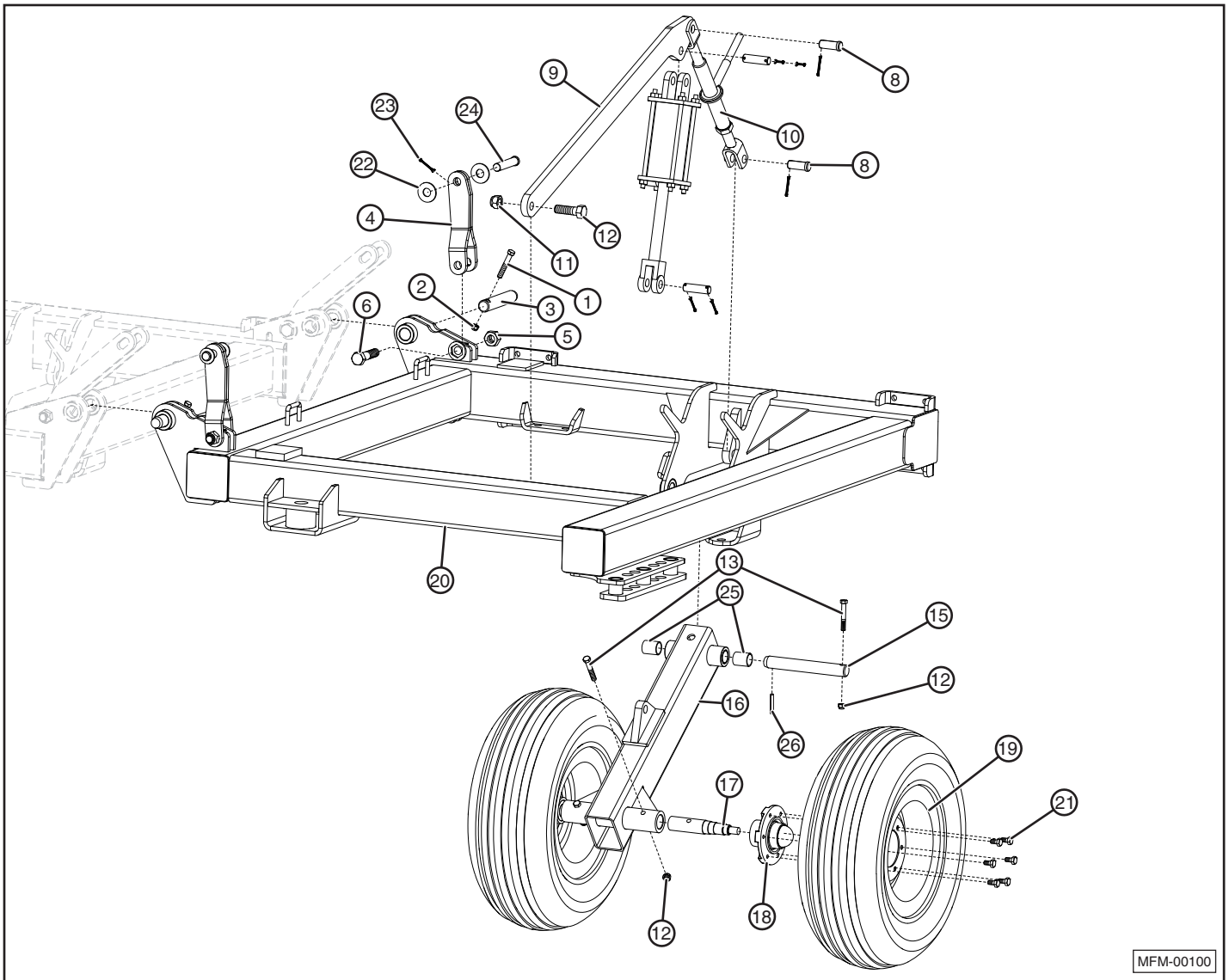

MFM-00100

Item	Part Number	Description
1	BHY-5635	9/16-12 X 3-1/2 GRADE 8 BOLT
2	NLT-5612	9/16-12 TOP LOCK NUT
3	SPR-2712	HINGE PIN, 1-1/2 X 8-1/4
4	RD-4425 RD-4426	WING FOLD ARM, LEFT WING FOLD ARM, RIGHT
5	NLT-1008	1-8 TOP LOCK NUT
6	BHY-1045	1- 8 X 4-1/2 GRADE 8 HEX BOLT
7	RD-4426	WING FOLD ARM, RIGHT
8	HD-1149	CLEVIS PIN, 1 x 2-1/2
9	RD-4624	WING AXLE CYLINDER ARM
10	HYO-2008	RATCHET JACK, 8" STROKE
11	NLT-1008	1-8 TOP LOCK NUT
12	NLT-5612	9/16-12 TOP LOCK NUT
13	BHY-5635	9/16-12 X 3-1/2 GRADE 8 BOLT
14	NLT-5612	9/16-12 TOP LOCK NUT

Item	Part Number	Description
15	RD-5061	WING AXLE PIVOT PIN
16	RD-4888	WING AXLE ASSEMBLY, DUAL
17	WDL-2505	WING AXLE SPINDLE
18	HD-1371	6-HOLE HUB ASSEMBLY
19	HD-1368	RIM, 15X8, 6 BOLT, 2900 LB.
	12614 12490	ASM, TIRE/RIM, IF320/70R15 TIRE ONLY, 11L - 15, 8 PLY
20	RD-4998 RD-4999	WING FRAME ASSEMBLY, LEFT OUTSIDE WING FRAME ASSEMBLY, RIGHT OUTSIDE
21	WB-5010	WHEEL BOLTS, 1/2-20 X 1-3/4
22	FW-0100	WASHER
23	CP-3620	COTTER PIN
24	CL-1005	CLEVIS PIN
25	RD-4889	BUSHING
26	RD-5062	ROLL PIN, 1/2 X 2-1/2

Disk Mount and Scrapers for CB-4200 Series

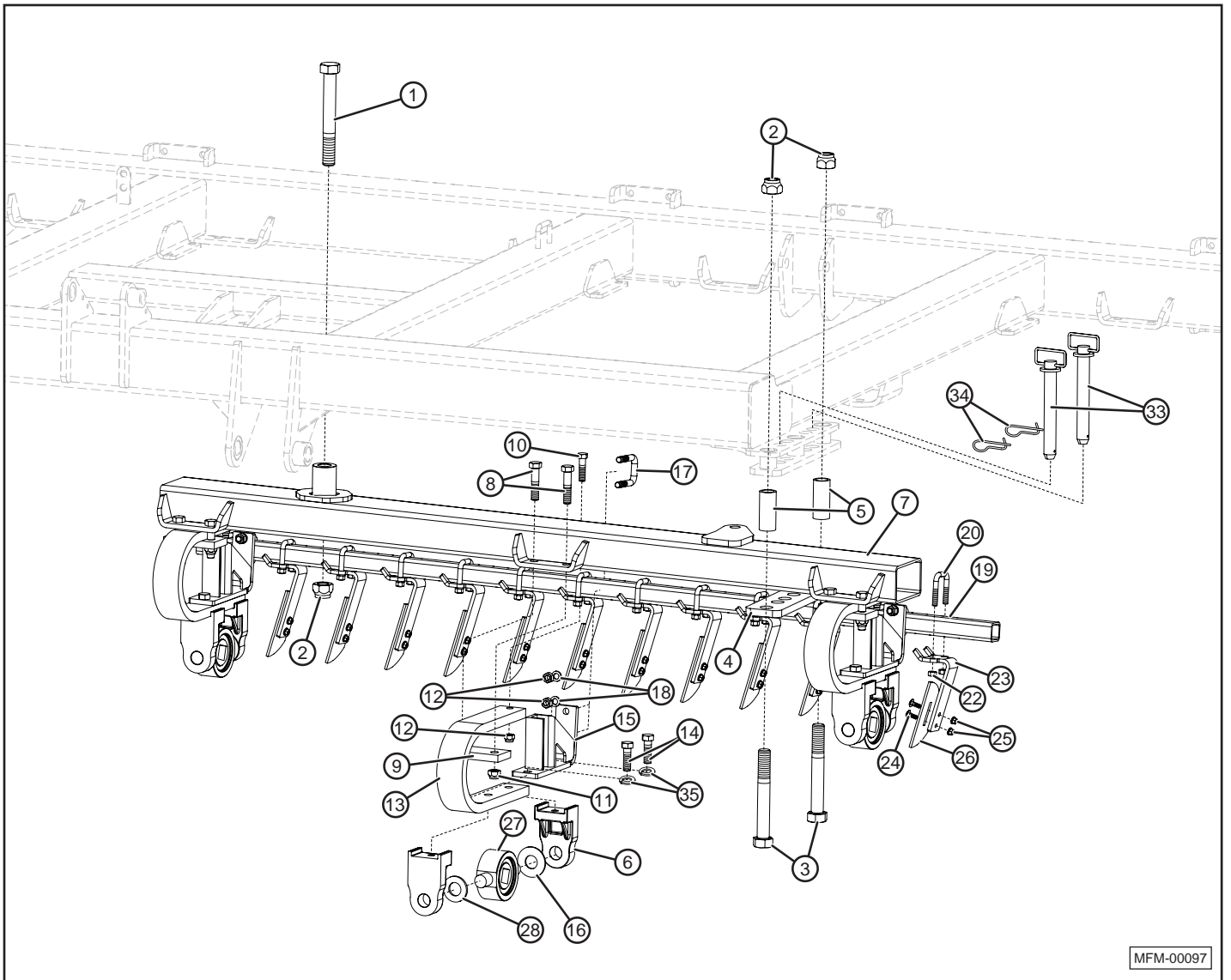

Disk Mount and Scrapers for CB-4200 (continued)

Item	Part Number	Description
1	BHY-1310	1-1/4-7 x 10 BOLT GD 8
2	NY-1307	1-1/4-7 NYLON LOCK NUT
3	BHY-1395	1-1/4-7 x 9-1/2 BOLT GD 8
4	RD-4890	DISK ADJUST CLAMP GD 8
5	QT-1209	SPACER
6	QT-1081	BEARING MOUNT, TRUNNION
7	RD-4950	DISK MOUNT TUBE LT 4112
	RD-4951	DISK MOUNT TUBE RT 4112
	RD-5043	DISK MOUNT TUBE LT 4114
	RD-5044	DISK MOUNT TUBE RT 4114
	RD-4952	DISK MOUNT TUBE LT 4116
	RD-4953	DISK MOUNT TUBE RT 4116
	RD-4954	DISK MOUNT TUBE MAIN LT 4120
	RD-4955	DISK MOUNT TUBE MAIN RT 4120
	RD-4956	DISK MOUNT TUBE WING LT 4120
	RD-4957	DISK MOUNT TUBE WING RT 4120
	RD-4896	DISK MOUNT TUBE MAIN LT 4125-4130
	RD-4913	DISK MOUNT TUBE MAIN RT 4125-4130
	RD-4922	DISK MOUNT TUBE WING LT 4125
	RD-4926	DISK MOUNT TUBE WING RT 4125
	RD-4904	DISK MOUNT TUBE WING LT 4130
	RD-4910	DISK MOUNT TUBE WING RT 4130
	RD-4958	DISK MOUNT TUBE MAIN LT 4135
	RD-4959	DISK MOUNT TUBE MAIN RT 4135
	RD-4960	DISK MOUNT TUBE WING LT 4135
	RD-4961	DISK MOUNT TUBE WING RT 4135
RD-4962	DISK MOUNT TUBE MAIN LT 4145	
RD-4963	DISK MOUNT TUBE MAIN RT 4145	
RD-4964	DISK MOUNT TUBE WING LT 4145	
RD-4965	DISK MOUNT TUBE WING RT 4145	
RD-4966	DISK MOUNT TUBE WING LT OUTSIDE 4145	
RD-4967	DISK MOUNT TUBE WING RT OUTSIDE 4145	
8	BHY-7535	3/4-10 X 3-1/2 GRADE 8 HEX BOLT
9	RT-2611	DISK SPRING CLAMP PLATE
10	BH-6325	5/8-11 X 2-1/2 GRADE 5 HEX BOLT
11	NLT-7510	3/4-10 TOP LOCK NUT
12	NLT-6311	5/8-11 TOP LOCK NUT
13	RD-4470	DISK GANG SPRING
14	BHY-7525	3/4-10 x 2-1/2 BOLT GD 8
15	RD-4895	SCRAPER MOUNT BRACKET

Item	Part Number	Description
16	RD-4842	DISK END SPACER
17	BU-5823	5/8-11 x 2 x 3 U-BOLT
18	LW-0063	5/8 LOCK WASHER
19	RD-4969	11 SCRAPER TUBE LT & RT 4112
	RD-4897	12 SCRAPER TUBE LT & RT 4114
	RD-4973	13 SCRAPER TUBE LT & RT 4116
	RD-4971	9 SCRAPER TUBE LT & RT MAIN 4120
	RD-4974	8 SCRAPER TUBE LT & RT WING 4120
	RD-4972	7 SCRAPER TUBE RT WING 4120
	RD-4897	12 SCRAPER TUBE LT & RT MAIN 4125 & 4130
	RD-4971	9 SCRAPER TUBE LT & RT WING 4125
	RD-4917	14 SCRAPER TUBE LT & RT WING 4130
	RD-4917	14 SCRAPER TUBE LT & RT MAIN 4135
RD-4971	9 SCRAPER TUBE LT & RT INSIDE WING 4135	
RD-4974	8 SCRAPER TUBE LT & RT OUTSIDE WING 4135	
RD-4917	14 SCRAPER TUBE LT & RT MAIN/INSIDE WING 4145	
RD-4969	11 SCRAPER TUBE LT & RT OUTSIDE WING 4145	
20	BU-1223	1/2 x 2 x 3 U-BOLT
21	—	—
22	NLF-5013	1/2-13 FLANGED LOCK NUT
23	RD-4898	SCRAPER ARM
24	BC-3810	3/8-16 X 1 CARRIAGE BOLTS
25	NLF-3816	3/8-16 FLANGED LOCK NUT
26	RD-4532	SCRAPER
27	10601	BEARING ASSEMBLY, TRUNNION
28	FW-0138	FLAT WASHER 1-3/8
29	RD-4900	HITCH PIN
30	RD-5076	TWIST CLIP
31	LW-0075	LOCK WASHER 3/4"

Disk Gang for CB-4200 Series

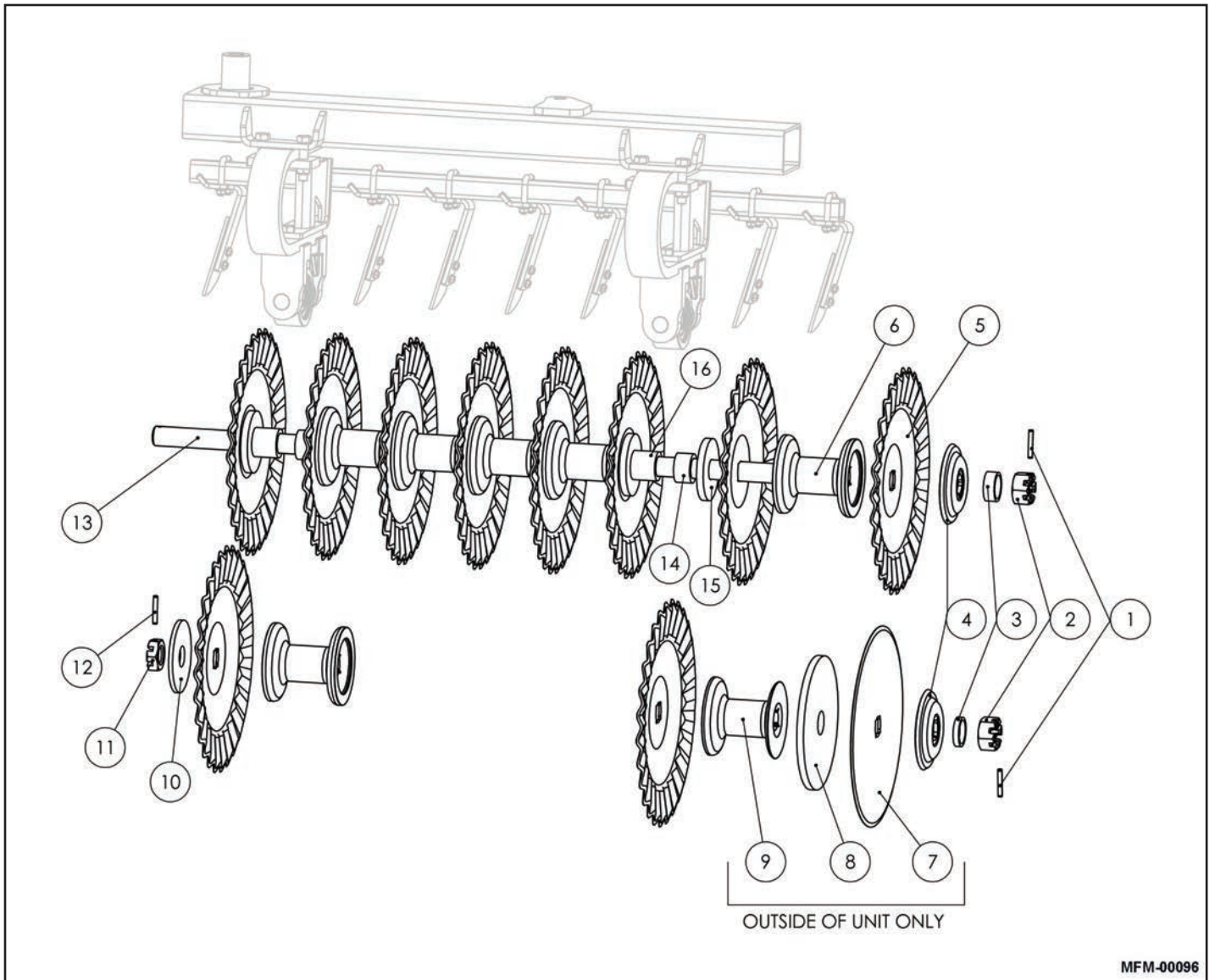

Item	Part Number	Description
Item	Part Number	Description
1	10655	PIN, SPRING ROLL 3/8 x 2.50
2	10657	NUT, FINISHED SLOTTED, 1-3/4-5, PLAIN
3	RD-4843	TUBE, ROUND, 2.625OD x 2.125ID - 1
3	13793	TUBE, ROUND, 2.625OD x 2.125ID - .5
3	10656	WASHER, 1.81 X 2.63 X .18
4	10600	DISK TENSION WASHER
5	12697	BLADE, DISK, COBRA, 20", 5mm
5	12793	BLADE, DISK, COBRA, 20", 6.5mm
6	RD-4850	DISK GANG SPOOL, 7"
7	RD-4925	BLADE, FLAT, 6mm, 18"
8	RD-4975	OUTSIDE DISK BLADE SUPPORT, 12"

Item	Part Number	Description
9	RD-4851	DISK GANG SPOOL, 6 3/8"
10	15131	RD DISK GANG END PLATE
11	10658	NUT, FINISHED SLOTTED JAM, 1-3/4-5, PLAIN
12	10746	DISK GANG SHAFT, 8-BLADES, 53.5"
12	10829	DISK GANG SHAFT, 9-BLADES, 60.5"
12	15121	DISK GANG SHAFT, 10-BLADES, 67.5"
12	10635	DISK GANG SHAFT, 11-BLADES, 74.25"
12	10634	DISK GANG SHAFT, 12-BLADES, 81.5"
12	15140	DISK GANG SHAFT, 14-BLADES, 95.5"
13	10727	BUSHING, 2.625OD x 1.75ID - 1.48
14	10729	PLATE, WASHER
15	15129	BUSHING, 2.625OD x 1.75ID - 2.25

Center Covering Disk For CB-4200 Series

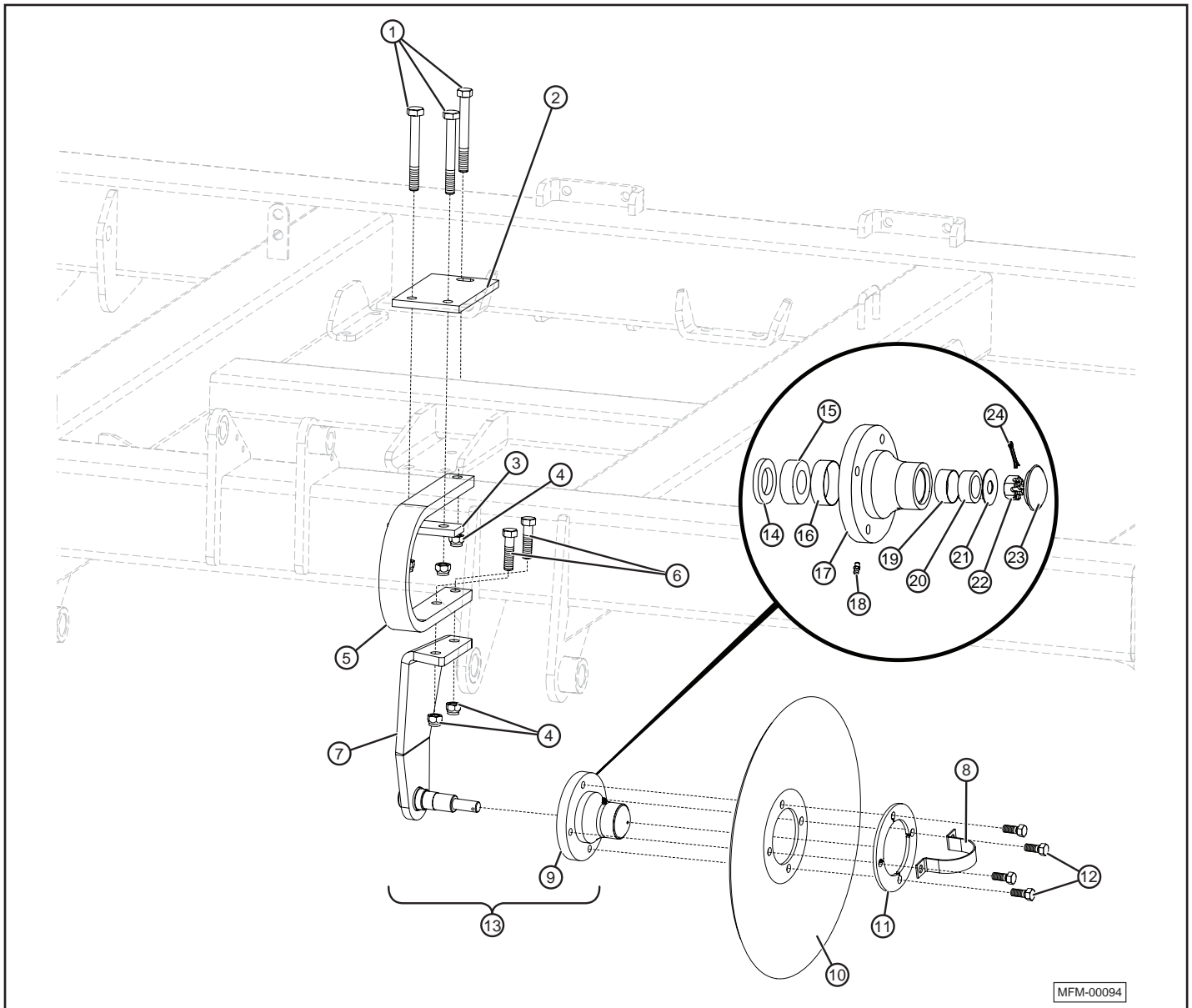

MFM-00094

Item	Part Number	Description
1	BH-6355	5/8-11 X 5-1/2 GRADE 5 HEX BOLT
2	RD-4464	SPRING CLAMP PLATE
3	RD-4432	SPRING CLAMP PLATE
4	NLT-6311	5/8-11 TOP LOCK NUT
5	QT-1027	CENTER DISK SPRING
6	BHY-6323	5/8-11 X 2-1/4 GRADE 8 HEX BOLT
7	RD-4902 RD-4901	LEVELER DISK MOUNT ASSY RT (shown) LEVELER DISK MOUNT ASSY LT
8	RD-5092	HUB RETAINER
9	HD-1170	4-BOLT HUB ASSEMBLY
10	QT-1025	BLADE, CONCAVE, 4-BOLT, 20"
11	QT-1026	CENTER DISK HUB PLATE
12	BHF-5013	WHEEL STUD, 1-1/4 GD 8

Item	Part Number	Description
13	RD-5095 RD-5096	LEVELER DISK ASSY W/HUB LT LEVELER DISK ASSY W/HUB RT (includes items 7 and 9)
14	HD-1160	GREASE SEAL
15	HD-1162	INNER BEARING
16	HD-1171	INNER RACE
17	HD-1161	HUB WITH RACES, 4 HOLE
18	GZ-2528	ZERK, GREASE
19	HD-1172	OUTER RACE
20	HD-1163	OUTER BEARING
21	HD-1164	SPINDLE FLAT WASHER
22	HD-1165	SPINDLE CASTLE NUT
23	HD-1167	DUST CAP
24	CP-5312	PIN, COTTER .150 x 1-1/4

* Items 14 - 24 are part of RD-5092 Hub Retainer Assembly, Item 9.

Center Wavy Disk for CB-4200 Series

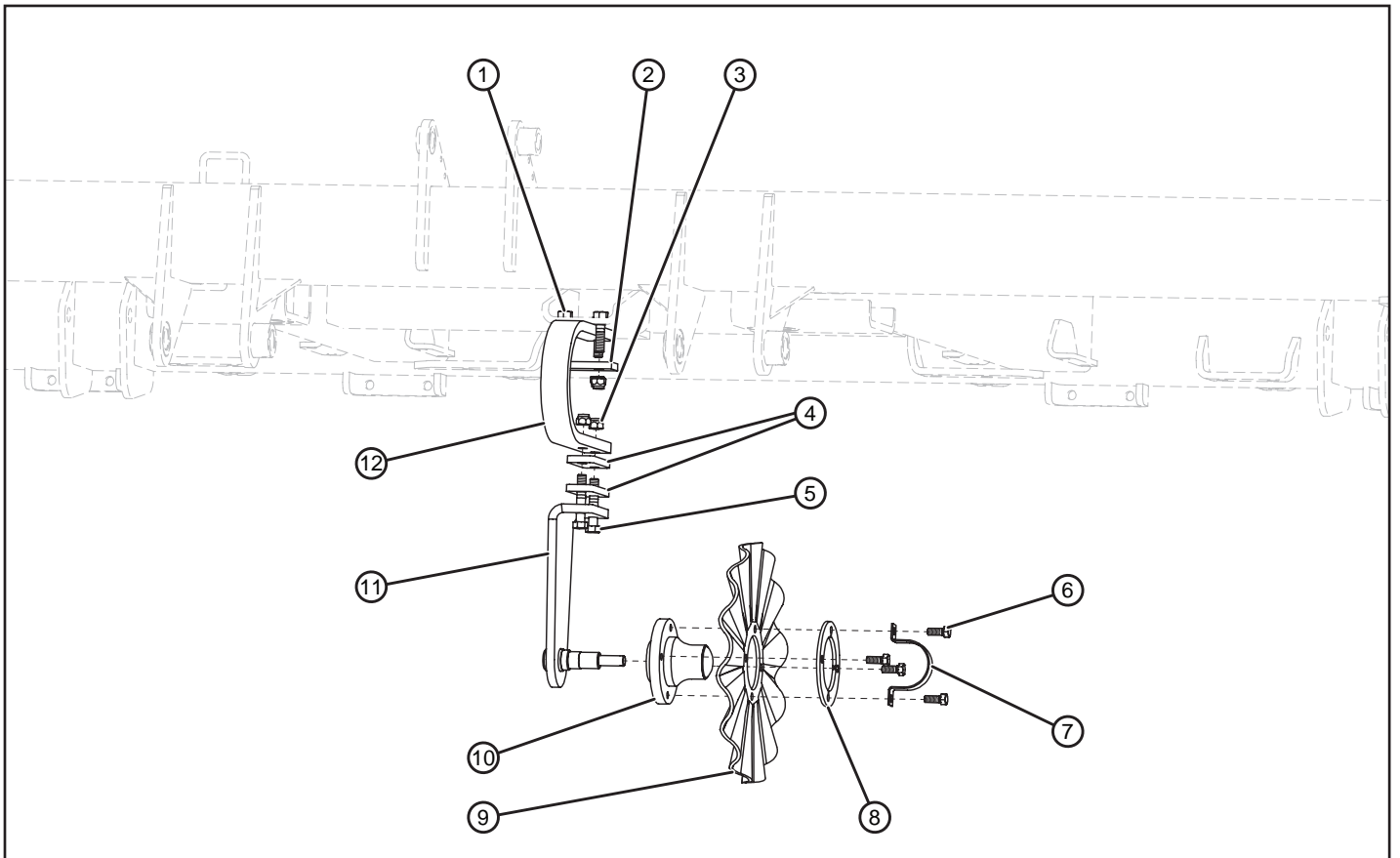

Item	Part Number	Description
1	BH-6325	5/8-11 x 2-1/2 HHCS GD 5
2	RD-4432	SPRING CLAMP
3	NLT-6311	5/8-11 TOP LOCK NUT
4	RD-4919	SPACER PLATE
5	BH-6335	5/8-11 x 3-1/2 HHCS GD 5
6	BHF-5013	HUB BOLT 1/2-20 x 1-1/4
7	RD-5092	HUB RETAINER
8	QT-1026	HUB PLATE
9	RD-4265	CENTER DISK, WAVY
10	HD-1170	HUB ASSY
11	RD-4886	CENTER DISK MOUNT
12	QT-1027	DISK SPRING

Dura-Reel for CB-4200 Series

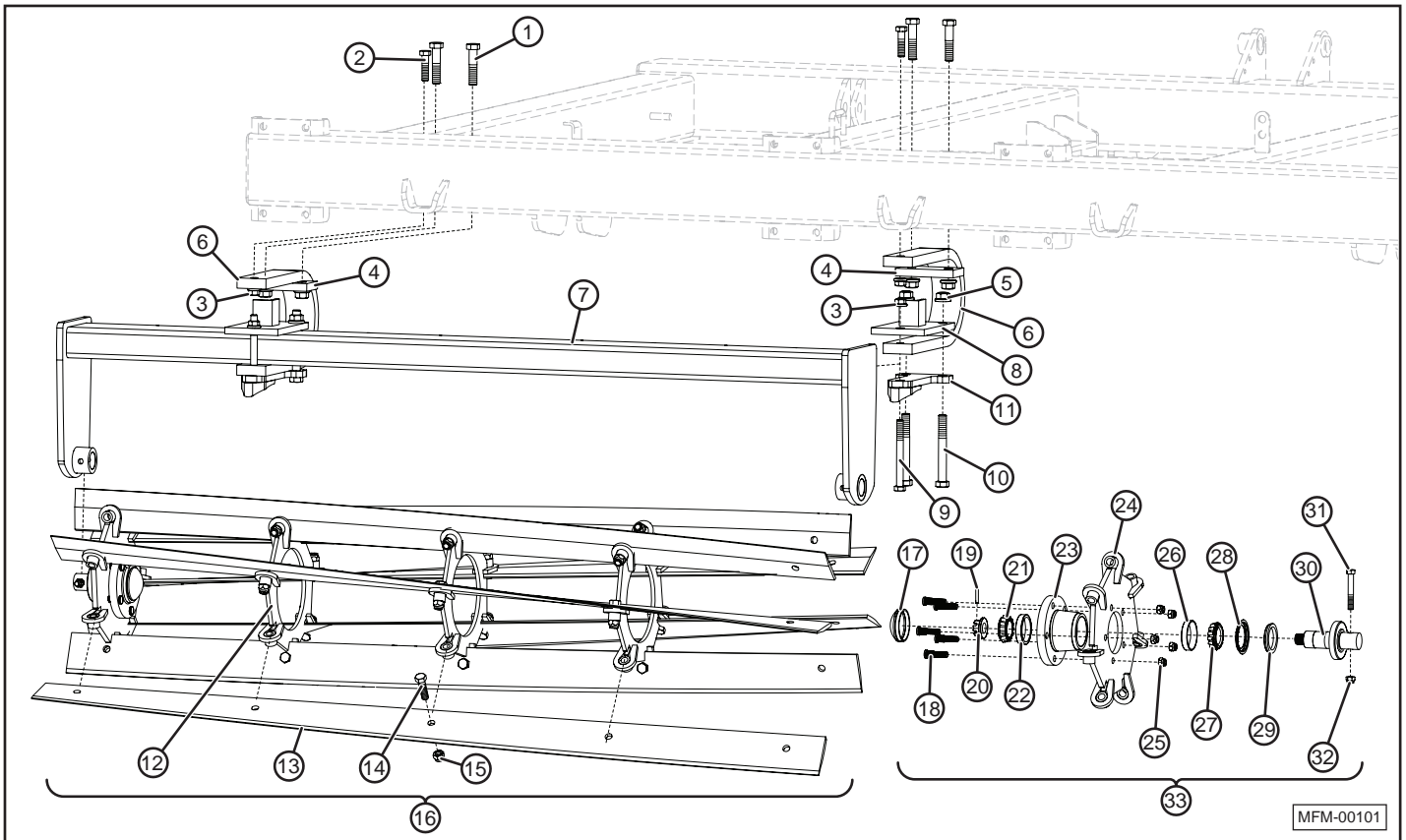

Item	Part Number	Description
1	BHY-7535	3/4-10 X 3-1/2 GRADE 8 BOLT
2	BH-6325	5/8-11 X 2-1/2 GRADE 5 BOLT
3	NLT-6311	5/8-11 TOP LOCK NUT
4	RT-2611	C-SPRING TOP CLAMP
5	NLT-7510	3/4-10 TOP LOCK NUT
6	RD-4470	SPIRAL REEL C-SPRING
7'	RD-5014 RD-5015 RD-5016 RD-5017 RD-5018 RD-5019 RD-5020	48" SPIRAL REEL MOUNT - 49" 51" SPIRAL REEL MOUNT - 52" 58" SPIRAL REEL MOUNT - 59" 66" SPIRAL REEL MOUNT - 67" 72" SPIRAL REEL MOUNT - 73" 80" SPIRAL REEL MOUNT - 81" 95" SPIRAL REEL MOUNT - 95"
8	RD-4485	C-SPRING CLAMP WITH STOP
9	BHY-6365	5/8-11 X 6-1/2 GRADE 8 HEX BOLT
10	BHY-7565	3/4-10 X 6-1/2 GRADE 8 HEX BOLT
11	RD-4849	SPIRAL REEL ROCK GUARD BRACKET
12	RD-5002	SPIRAL REEL BLADE INNER BRACKET
13'	SPR-5048 SPR-5051 SPR-5058 SPR-5066 SPR-5072 SPR-5080 SPR-5095	SPIRAL REEL BLADE, 48" SPIRAL REEL BLADE, 51" SPIRAL REEL BLADE, 58" SPIRAL REEL BLADE, 66" SPIRAL REEL BLADE, 72" SPIRAL REEL BLADE, 80" SPIRAL REEL BLADE, 95"
14	BHP-6323	5/8 X 2-1/4 HEX BOLT
15	NLT-6311	5/8-11 TOP LOCK NUT

Item	Part Number	Description
16'	RD-5022 RD-5023 RD-5024 RD-5025 RD-5026 RD-5027 RD-5028	48" SPIRAL REEL 51" SPIRAL REEL 58" SPIRAL REEL 66" SPIRAL REEL 72" SPIRAL REEL 80" SPIRAL REEL 95" SPIRAL REEL
17	RD-4859	END CAP
18	RD-4861	WHEEL BOLT
19	RD-4863	ROLL PIN
20	RD-4862	CASTLE NUT
21	RD-4857	BEARING CONE
22	RD-4858	BEARING CUP
23	RD-4855	5 BOLT REEL HUB ASSY
24	RD-5001	5 BOLT END PLATE
25	NL-5020	NUT, 1/2-20
26	RD-4857	BEARING CUP
27	RD-4858	BEARING CONE
28	RD-4856	SEAL, COUNTERFACE
29	RD-4865	SEAL
30	RD-4864	SPINDLE WITH GRASS GUARD AND SEAL
31	RD-5055	BOLT, 1/2-13 X 3-1/4, GD8
32	NLT-5013	NUT, TOP LOCK 1/2-13
33	RD-4854	HUB ASSY. (ITEMS 17-23, 26-30)

¹Refer to layout diagram for position and size on each unit.

Lift Arm for 3 Bar FA Harrow Sections

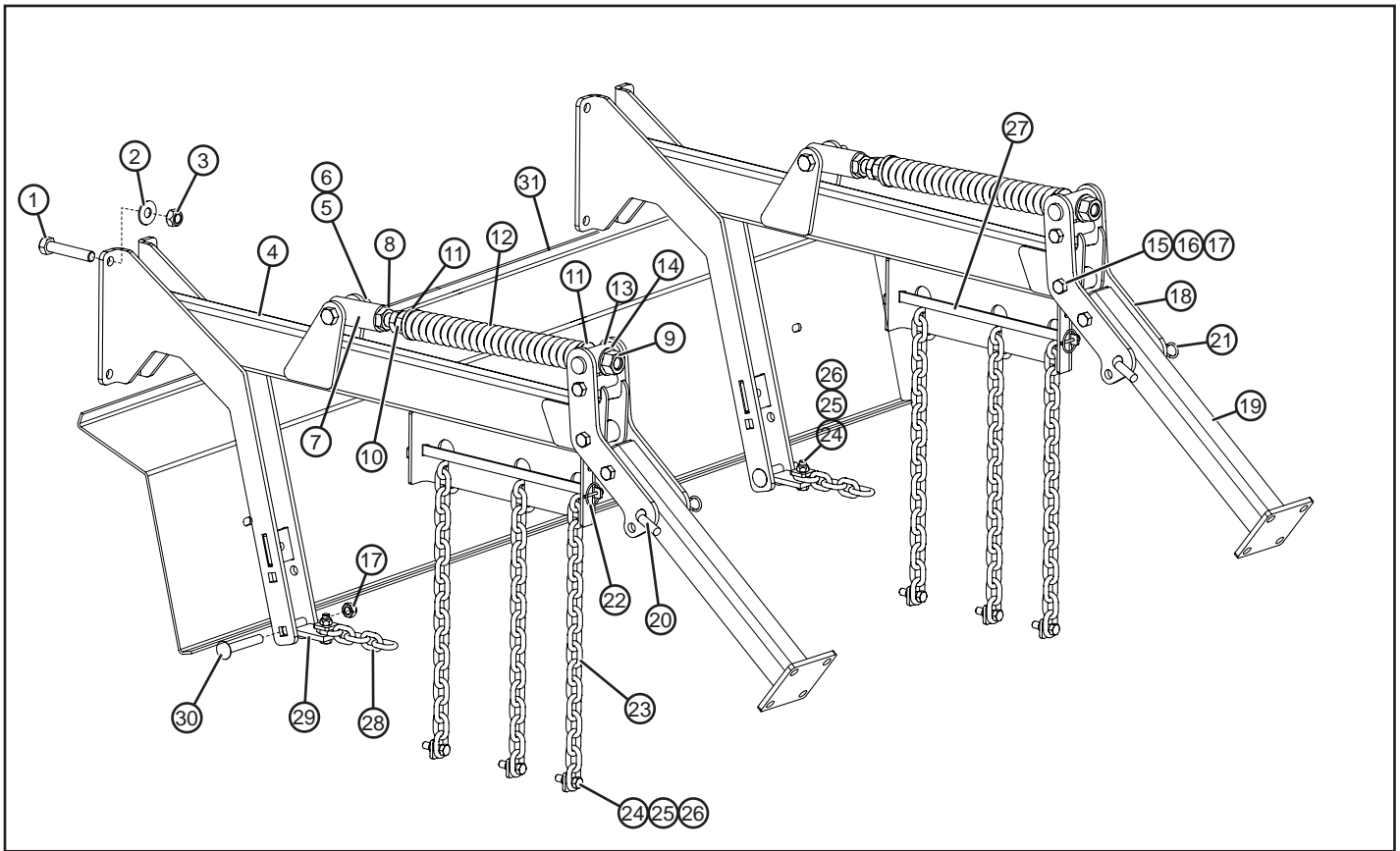

Item	Part Number	Description
1	BH-6320	BOLT, HEX, 5/8-11 X 2, GRADE 5
2	LW-0063	WASHER, LOCK, 5/8
3	NH-6311	NUT, HEX, 5/8-11
4	10962	ARM, LIFT
5	BH-7540	BOLT, HEX, 3/4-10 X 4, GRADE 5
6	NLT-7510	NUT, TOP LOCK, 3/4-10
7	10713	TUBE, ROUND, ADJUSTMENT
8	NHJ-1008	NUT, HEX, JAM, 1-8
9	10959	BOLT, SPECIAL, GRADE 8
10	NH-1008	NUT, HEX, 1-8
11	10715	WASHER
12	10682	SPRING, COMPRESSION
13	10714	BUSHING, TRUNNION
14	FW-0100	WASHER, FLAT
15	BH-6350	BOLT, HEX, 5/8-11 X 5 GRADE 5
16	10716	TUBE, ROUND
17	NLT-6311	NUT, TOP LOCK, 5/8-11
18	10718	PLATE, PIVOT
19	10952	ARM, PIVOT
20	11033	PIN, HITCH, 5/8 X 4"
21	PB-0009	PIN, BRIDGE, #9

Item	Part Number	Description
22	PC-1913	CLICK PIN, 3/16 X 1-9/16
23	CH-0818	LIFT CHAIN, 18 LINK
24	BH-5018	BOLT, HEX, 1/2-13 X 1-3/4 GRADE 5
25	HDD-016	WASHER, SQUARE, 1/2"
26	NLT-5013	NUT, TOP LOCK, 1/2-13
27	10957	BAR, LOCK
28	CH-0805	PULL CHAIN, 5 LINK
29	FA-4105	PULL POINT ASSEMBLY
30	BC-6340	BOLT, CARRIAGE, 5/8 X 4
31	RD-4615	DEBRIS SHROUD - 51"
	RD-4616	DEBRIS SHROUD - 62"
	RD-4617	DEBRIS SHROUD - 73"
	RD-4618	DEBRIS SHROUD - 84"
	RD-4619	DEBRIS SHROUD - 95"

3 Bar FA Harrow Section

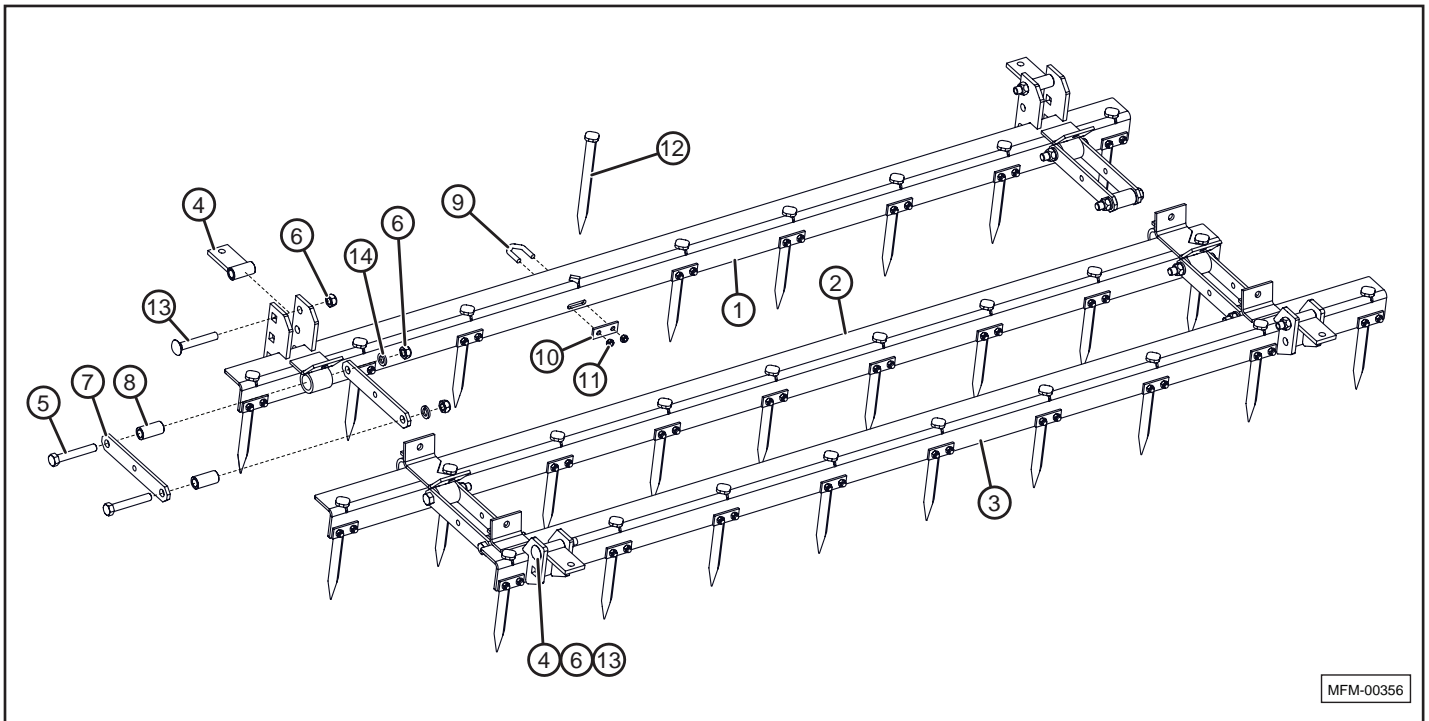

Item	Part Number	Description
1	FA-551	NUMBER ONE HARROW BAR (FA-500-3)
	FA-651	NUMBER ONE HARROW BAR (FA-600-3)
	FA-751	NUMBER ONE HARROW BAR (FA-700-3)
	FA-851	NUMBER ONE HARROW BAR (FA-800-3)
	FA-951	NUMBER ONE HARROW BAR (FA-900-3)
2	FA-556	NUMBER TWO HARROW BAR (FA-500-3)
	FA-656	NUMBER TWO HARROW BAR (FA-600-3)
	FA-756	NUMBER TWO HARROW BAR (FA-700-3)
	FA-856	NUMBER TWO HARROW BAR (FA-800-3)
	FA-956	NUMBER TWO HARROW BAR (FA-900-3)
3	FA-557	NUMBER THREE HARROW BAR (FA-500-3)
	FA-657	NUMBER THREE HARROW BAR (FA-600-3)
	FA-757	NUMBER THREE HARROW BAR (FA-700-3)
	FA-857	NUMBER THREE HARROW BAR (FA-800-3)
	FA-957	NUMBER THREE HARROW BAR (FA-900-3)
4	FA-4105	PLATE, PIVOT
5	BH-6340	BOLT, HEX, 5/8-11 X 4 GRADE 5

Item	Part Number	Description
6	NLT-6311	NUT, TOP LOCK, 5/8-11
7	CT-105	CONNECTOR, FLAT
8	CT-102	BUSHING, INNER
9	BV-3812	3/8" V BOLT
10	FA-4103	PLATE, 3/8" V-BOLT
11	NLT-3816	NUT, TOP LOCK, 3/8-16
12	FA-4110	TOOTH, 3/4" X 10"
13	BC-6340	BOLT, CARRIAGE, 5/8-11 X 4 GRADE 5
14	LW-0063	WASHER, LOCK, 5/8

Lift Arm for 5 Bar FA Harrow Section

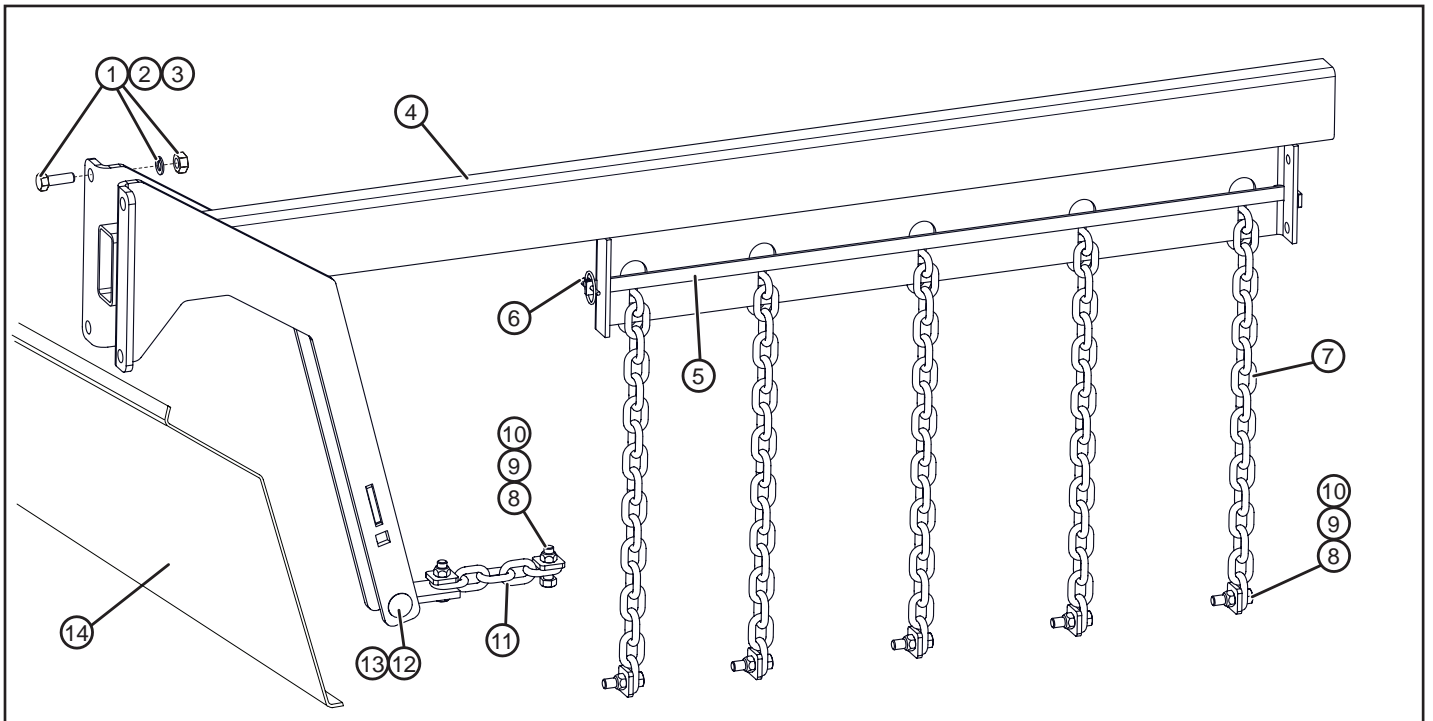

Item	Part Number	Description
1	BH-6320	BOLT, HEX, 5/8-11 X 2, GRADE 5
2	LW-0063	WASHER, LOCK, 5/8
3	NH-6311	NUT, HEX, 5/8-11
4	12706	ARM, LIFT
5	RD-4629	BAR, LOCK
6	PC-1913	CLICK PIN, 3/16 X 1-9/16
7	CH-0816	LIFT CHAIN, 16 LINK
8	BH-5018	BOLT, HEX, 1/2-13 X 1-3/4 GRADE 5
9	HDD-016	WASHER, SQUARE, 1/2"

Item	Part Number	Description
10	NLT-5013	NUT, TOP LOCK, 1/2-13
11	CH-0805	PULL CHAIN, 5 LINK
12	NLT-6311	NUT, TOP LOCK, 5/8-11
13	BC-6340	BOLT, CARRIAGE, 5/8 X 4
14	RD-4615	DEBRIS SHROUD - 51"
	RD-4616	DEBRIS SHROUD - 62"
	RD-4617	DEBRIS SHROUD - 73"
	RD-4618	DEBRIS SHROUD - 84"
	RD-4619	DEBRIS SHROUD - 95"

5 Bar FA Harrow Section

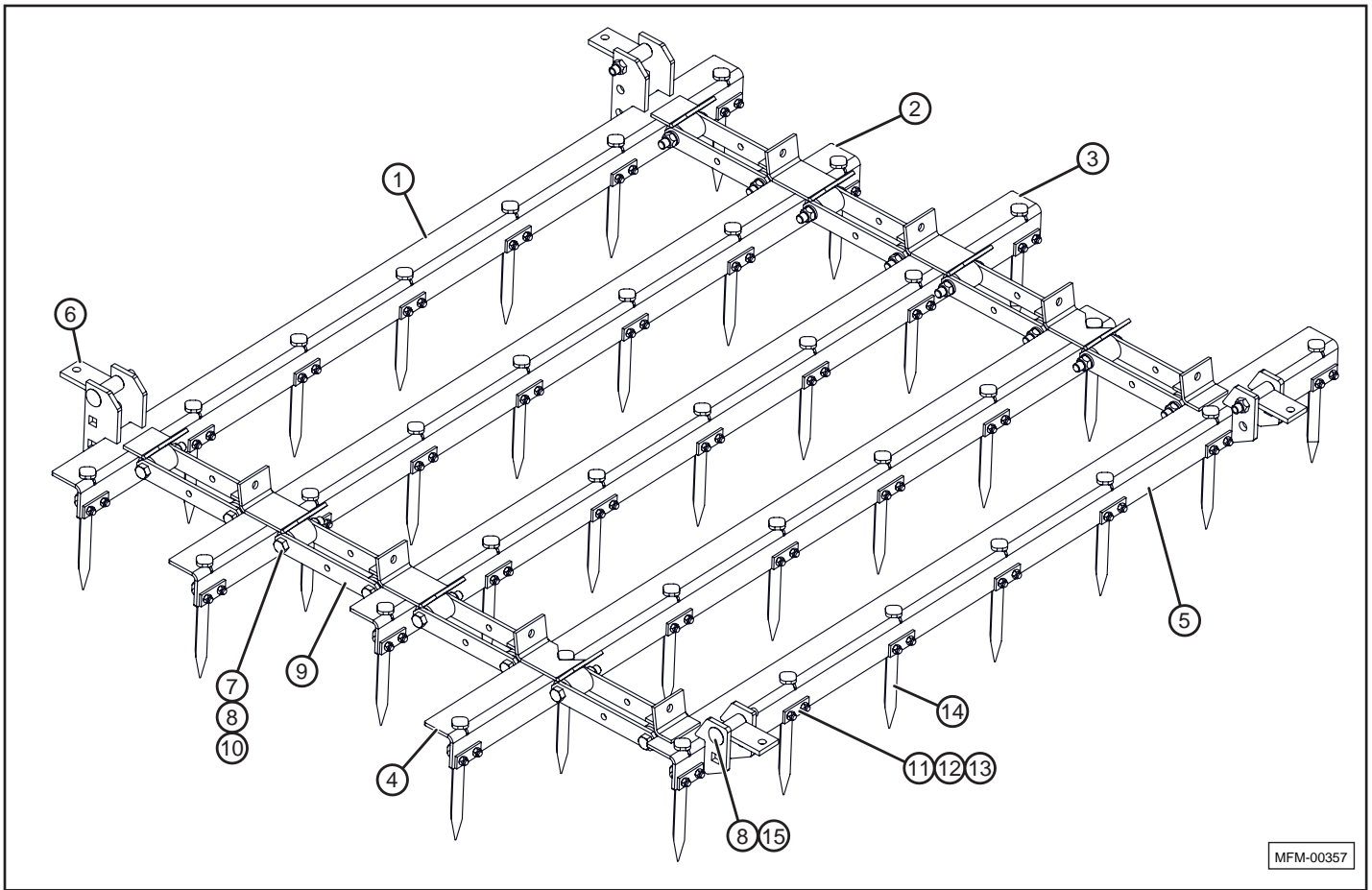

Item	Part Number	Description
1	FA-551 FA-651 FA-751 FA-851	NUMBER ONE HARROW BAR (FA-500-5) NUMBER ONE HARROW BAR (FA-600-5) NUMBER ONE HARROW BAR (FA-700-5) NUMBER ONE HARROW BAR (FA-800-5)
2	FA-552 FA-652 FA-752 FA-852	NUMBER TWO HARROW BAR (FA-500-5) NUMBER TWO HARROW BAR (FA-600-5) NUMBER TWO HARROW BAR (FA-700-5) NUMBER TWO HARROW BAR (FA-800-5)
3	FA-553 FA-653 FA-753 FA-853	NUMBER THREE HARROW BAR (FA-500-5) NUMBER THREE HARROW BAR (FA-600-5) NUMBER THREE HARROW BAR (FA-700-5) NUMBER THREE HARROW BAR (FA-800-5)
4	FA-556 FA-656 FA-756 FA-856	NUMBER FOUR HARROW BAR (FA-500-5) NUMBER FOUR HARROW BAR (FA-600-5) NUMBER FOUR HARROW BAR (FA-700-5) NUMBER FOUR HARROW BAR (FA-800-5)
5	FA-557 FA-657 FA-757 FA-857	NUMBER FIVE HARROW BAR (FA-500-5) NUMBER FIVE HARROW BAR (FA-600-5) NUMBER FIVE HARROW BAR (FA-700-5) NUMBER FIVE HARROW BAR (FA-800-5)
6	FA-4105	PLATE, PIVOT

Item	Part Number	Description
7	BH-6340	BOLT, HEX, 5/8-11 X 4 GRADE 5
8	NLT-6311	NUT, TOP LOCK, 5/8-11
9	CT-105	CONNECTOR, FLAT
10	CT-102	BUSHING, INNER
11	BV-3812	3/8" V BOLT
12	FA-4103	PLATE, 3/8" V-BOLT
13	NLT-3816	NUT, TOP LOCK, 3/8-16
14	FA-4110	TOOTH, 3/4" X 10"
15	BC-6340	BOLT, CARRIAGE, 5/8-11 X 4 GRADE 5

Lift Arm and Spur-Till Mount

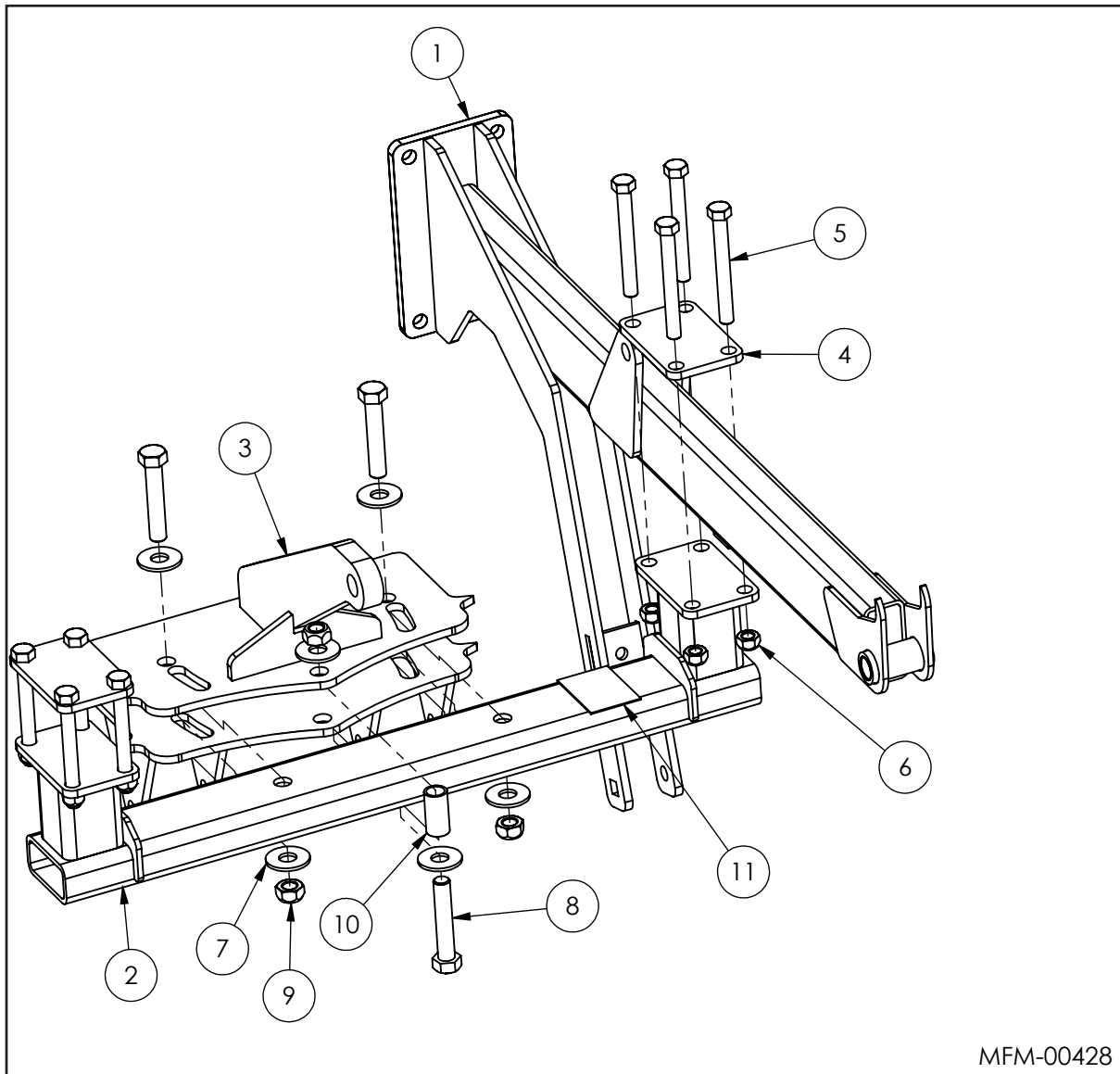

MFM-00428

Item	Part Number	Description
1	14450	LIFT ARM,CB,SPUR-TILL
2	14125	ASSY, MOUNT (CB-4212, 4214, 4225, 4230)
2	14126	ASSY, MOUNT (CB-4212, 4220, 4225)
2	14154	ASSY, MOUNT (CB-4220, 4235)
2	14156	ASSY, MOUNT (CB-4220, 4235)
2	14190	ASSY, MOUNT (CB-4230, 4235)
3	14518	ASSY, PIVOT MOUNT
4	14395	PLATE, MOUNT
5	BH-6355	BOLT, HEX,5/8-11X5.5, GD5
6	NLT-6311	NUT, LOCK, TOP,5/8-11
7	FW-0075	WASHER, FLAT, .75, GD8
8	BH-7540	BOLT, HEX,3/4-10X4, GD5
9	NLT-7510	NUT, LOCK, TOP, 3/4-10
10	15079	BUSHING
11	15426	DECAL, ST ANGLE

Spur-Till Mount

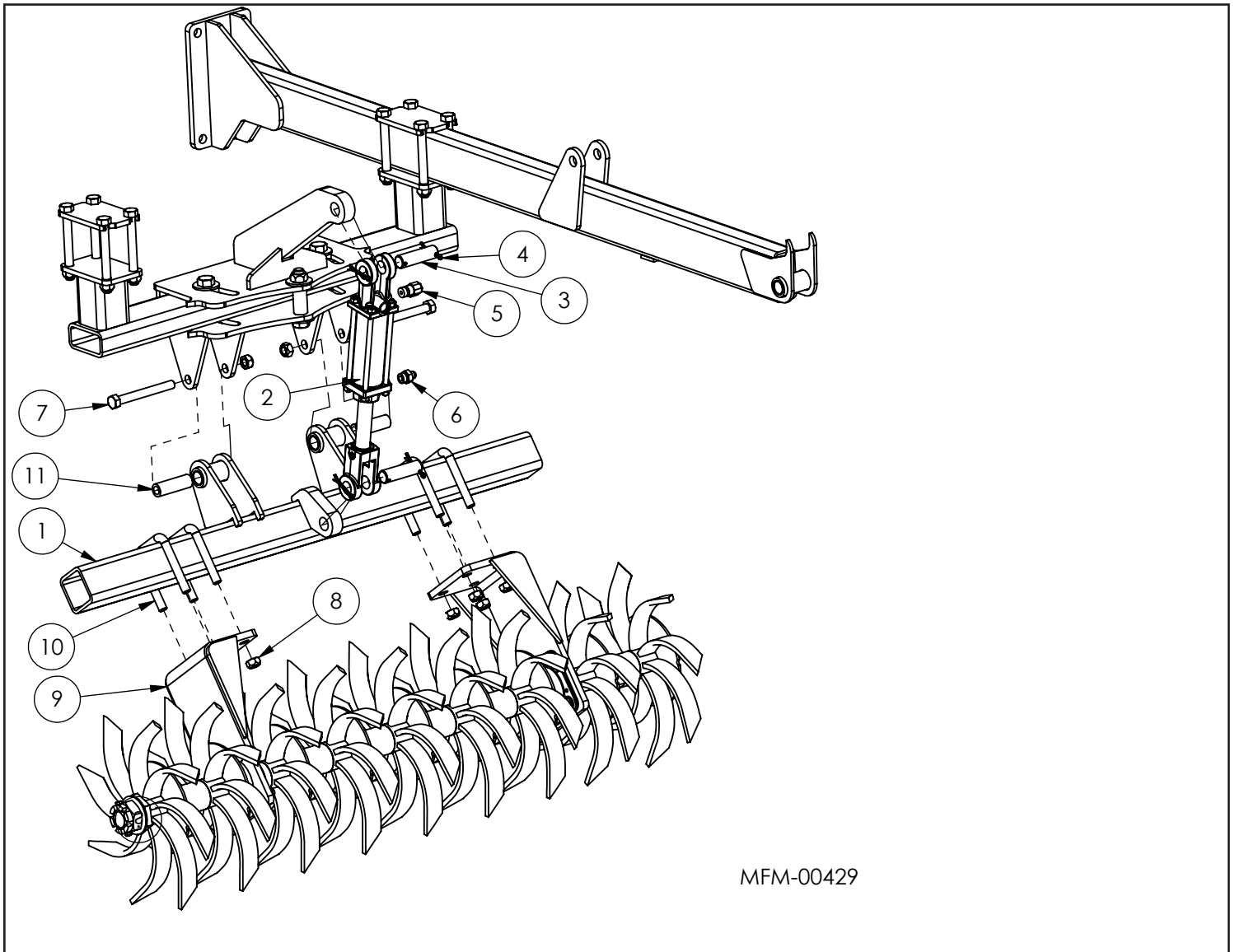

MFM-00429

Item	Part Number	Description
1	14160	SPUR-TILL MOUNT (44")
1	14135	SPUR-TILL MOUNT (58")
1	14138	SPUR-TILL MOUNT (65")
1	14106	SPUR-TILL MOUNT (74")
2	HYC-32004	HYD CYLINDER, 2 x 4
3	HYO-2103	PIN, CYLINDER CLEVIS, 1x3-1/2
4	CP-3620	PIN, COTTER, 3/16x2
5	HYF-2820	HYD ELBOW, 9/16M - 3/4Morb
6	HYF-3820	HYD ADAPTER, 9/16M-3/4Morb
7	BH-6355	BOLT, HEX, 5/8-11X5.5, GD5
8	NLT-6311	NUT, LOCK, TOP, 5/8-11

Item	Part Number	Description
9	N/A	SPUR-TILL, LH 9
10	BU-5834	U-BOLT, 5/8-11X3X4.5
11	10716	TUBE, ROUND

Spur-Till Gang

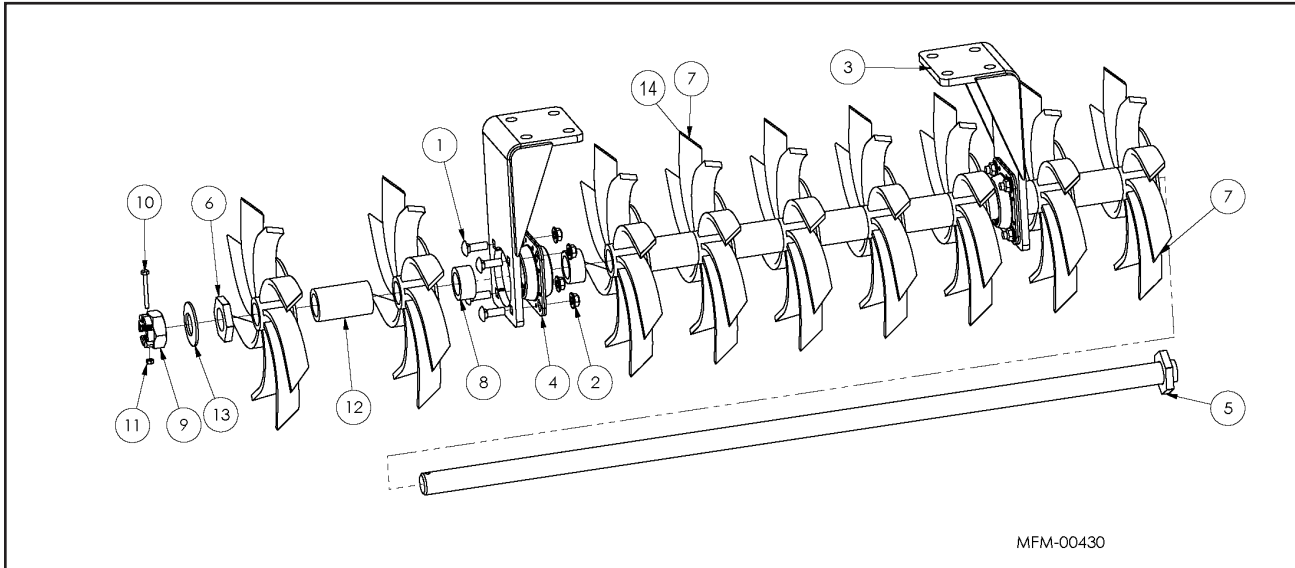

Item	Part Number	Description	Item	Part Number	Description
1	BC-5015	BOLT, CARRIAGE, 1/2-13X1.5, GD5	7	13916	SPURTILL WHEEL, LH
2	14599	NUT, UNITORQUE LOCK, FLANGED, 1/2-13 GRG ZP	8	14137	TUBE
3	13785	LEVELER MOUNT	9	14400	1-1/2"-6 SLOTTED NUT
4	14204	BEARING, FLANGED, 1.50 RND	10	BH-2525	BOLT, HEX, 1/4-20X2.5, GD5
5	14420	WELDED SHAFT-71.22	11	NLT-2520	NUT, TOP LOCK 1/4-20
5	14421	WELDED SHAFT-89.18	12	13968	TUBE
5	14426	WELDED SHAFT-65.22	13	14694	BELLEVILLE DISC SPRING
5	14431	WELDED SHAFT-77.19	14	13960	SPURTILL WHEEL, RH
5	14432	WELDED SHAFT53.22			
5	14443	WELDED SHAFT-95.19			
6	13969	PLATE, WASHER			

Rolling Basket

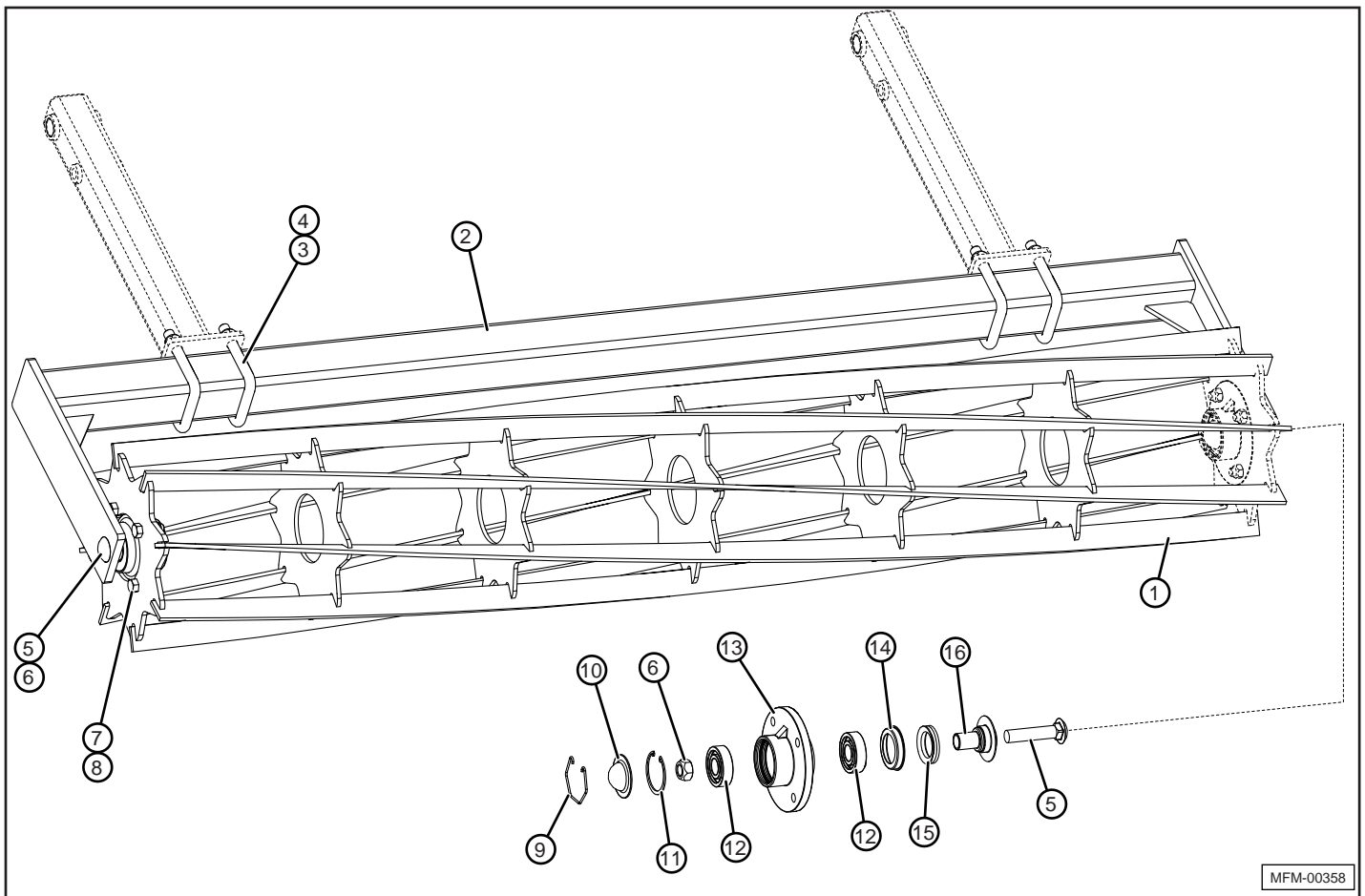

MFM-00358

Item	Part Number	Description
1 ¹	SRB-1552 SRB-1563 SRB-1574 SRB-1585	ROLLING BASKET – 52" ROLLING BASKET – 63" ROLLING BASKET – 74" ROLLING BASKET – 85"
2	RD-5080 RD-5079 RD-5078 RD-5077	BASKET MOUNT TUBE – 52" BASKET MOUNT TUBE – 63" BASKET MOUNT TUBE – 74" BASKET MOUNT TUBE – 85"
3	NLT-6311	NUT, TOP LOCK 5/8-11
4	BU-5834	5/8" U BOLT
5	BC-7535	BOLT, CARRIAGE, 3/4-10 X 3-1/2, GRADE 5
6	NLT-7510	NUT, TOP LOCK, 3/4-10
7	BH-5018	BOLT, HEX, 1/2-13 X 1-3/4 GRADE 5

Item	Part Number	Description
8	NLT-5013	NUT, TOP LOCK, 1/2-13
9	13081	RETAINING RING
10	13078	DUST CAP
11	13076	SNAP RING
12	13074	BEARING,SEALED,1" ID
13	13080	HUB
14	13079	SEAL COUNTERFACE
15	13075	V-SEAL,1.59" ID
16	13077	BEARING SLEEVE W/GUARD

¹Refer to layout diagram for position and size on each unit.

Lift Arm for Double Rolling Baskets

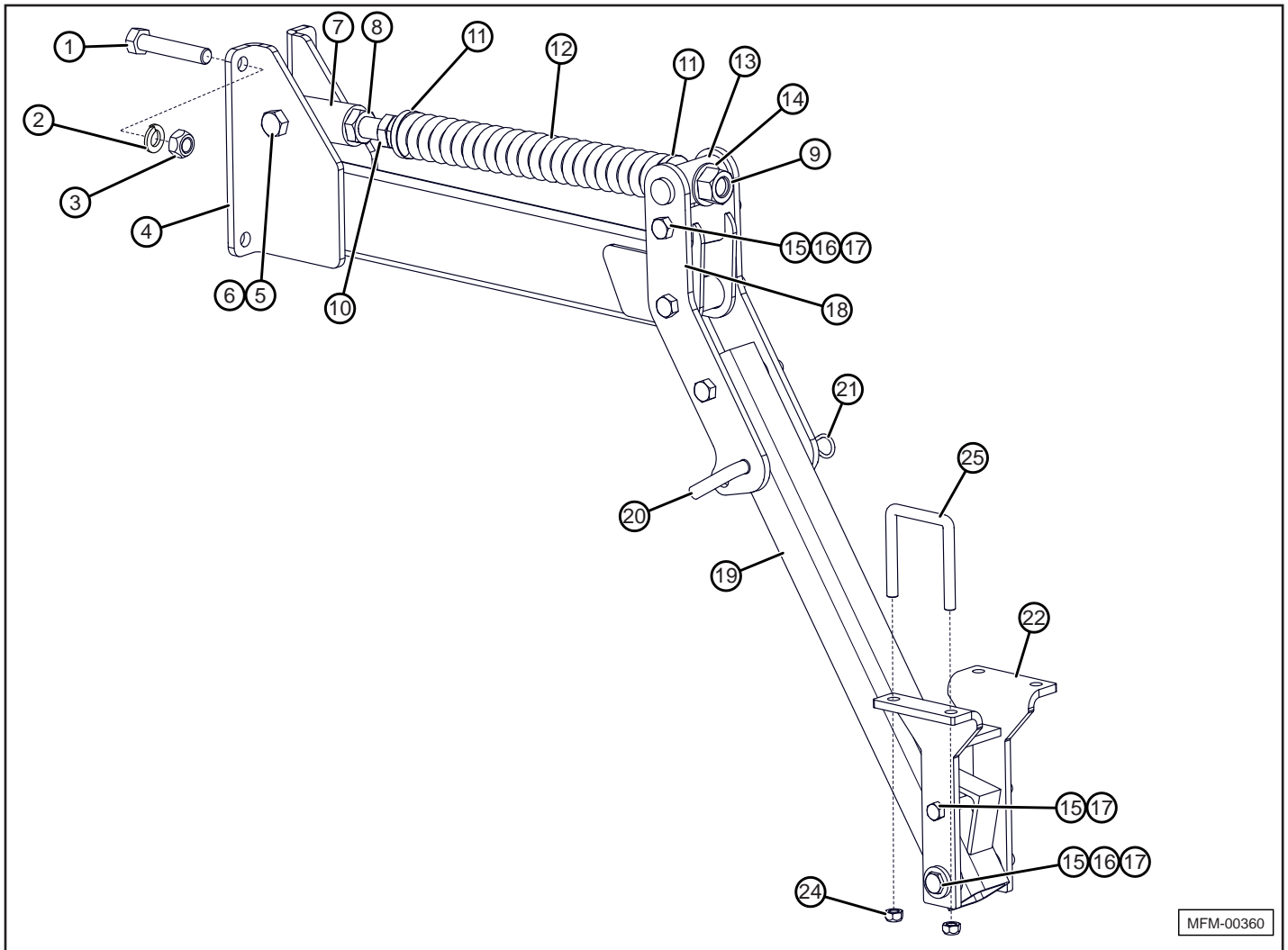

MFM-00360

Item	Part Number	Description
1	BH-6320	BOLT, HEX, 5/8-11 X 2, GRADE 5
2	LW-0063	WASHER, LOCK, 5/8
3	NH-6311	NUT, HEX, 5/8-11
4	11436	ARM, LIFT
5	BH-7540	BOLT, HEX, 3/4-10 X 4, GRADE 5
6	NLT-7510	NUT, TOP LOCK, 3/4-10
7	10713	TUBE, ROUND, ADJUSTMENT
8	NHJ-1008	NUT, HEX, JAM, 1-8
9	10959	BOLT, SPECIAL, GRADE 8
10	NH-1008	NUT, HEX, 1-8
11	10715	WASHER
12	10682	SPRING, COMPRESSION
13	10714	BUSHING, TRUNNION
14	FW-0100	WASHER, FLAT
15	BH-6350	BOLT, HEX, 5/8-11 X 5 GRADE 5

Item	Part Number	Description
16	10716	TUBE, ROUND
17	NLT-6311	NUT, TOP LOCK, 5/8-11
18	11440	PLATE
19	11441	TUBE ASSEMBLY
20	11033	PIN, HITCH, 5/8 X 4"
21	PB-0009	PIN, BRIDGE, #9
22	13601	BRACKET, MOUNTING, DOUBLE ROLLING BASKET
23	BH-5050	BOLT, HEX, 1/2-13 X 5" GRADE 5
24	NLT-5013	NUT, TOP LOCK, 1/2-13
25	BU-1234	1/2" U BOLT

Double Rolling Basket

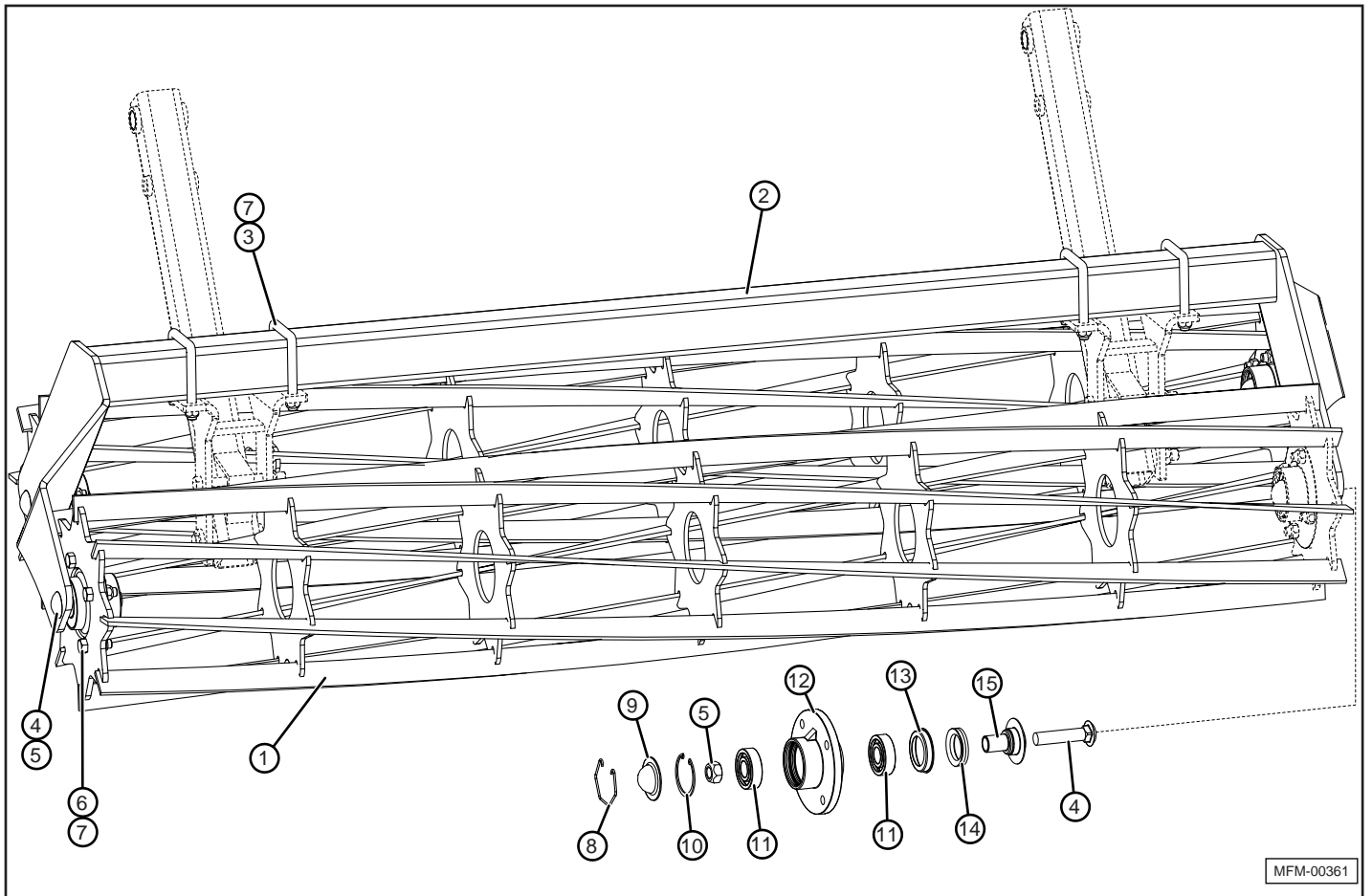

Item	Part Number	Description
1	SRB-1552 SRB-1563 SRB-1574 SRB-1585	ROLLING BASKET – 52" ROLLING BASKET – 63" ROLLING BASKET – 74" ROLLING BASKET – 85"
2	11444 11628 11498 11452	BASKET MOUNT TUBE – 52" BASKET MOUNT TUBE – 63" BASKET MOUNT TUBE – 74" BASKET MOUNT TUBE – 85"
3	BU-1234	1/2" U BOLT
4	BC-7535	BOLT, CARRIAGE, 3/4-10 X 3-1/2, GRADE 5
5	NLT-7510	NUT, TOP LOCK, 3/4-10
6	BH-5018	BOLT, HEX, 1/2-13 X 1-3/4 GRADE 5

Item	Part Number	Description
7	NLT-5013	NUT, TOP LOCK, 1/2-13
8	13081	RETAINING RING
9	13078	DUST CAP
10	13076	SNAP RING
11	13074	BEARING,SEALED,1" ID
12	13080	HUB
13	13079	SEAL COUNTERFACE
14	13075	V-SEAL,1.59" ID
15	13077	BEARING SLEEVE W/GUARD

Wheel Lift Hydraulics for CB-4212, 4214

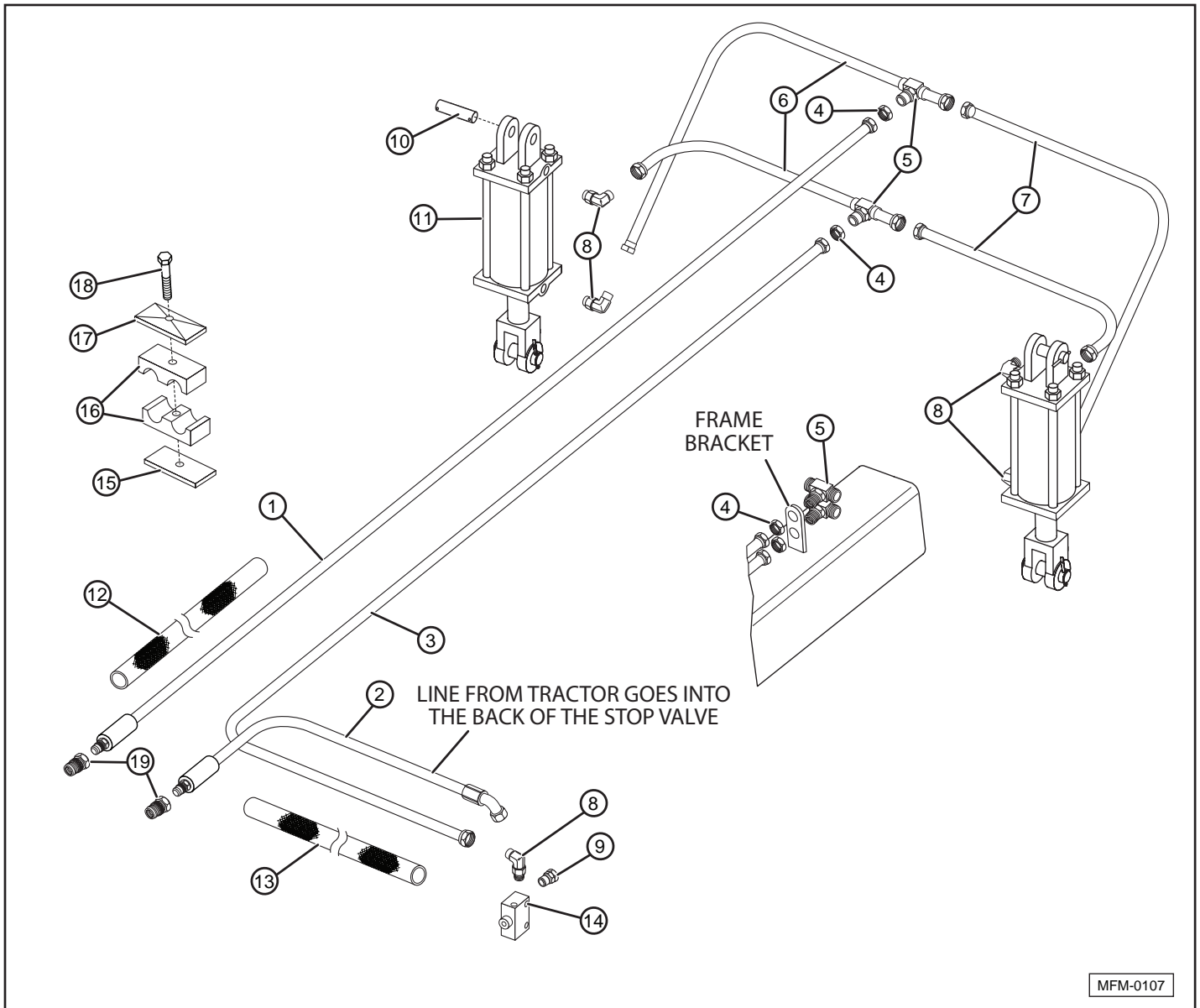

Item	Part Number	Description
1	HYH-3255	1/2" X 255" HYDRAULIC HOSE
2	HYH-1030	1/2" X 214" HYDRAULIC HOSE
3	HYH-2094	1/2" X 94" HYDRAULIC HOSE
4	HYO-4002	1/2" TEE NUT
5	HYF-1222	TEE (1/2"m - 1/2"m - 1/2"m)
6	HYH-2028 HYH-2030	1/2" X 28" HYDRAULIC HOSE (4112) 1/2" X 30" HYDRAULIC HOSE (4114, 4116)
7	HYH-2070 HYH-2080	1/2" X 70" HYDRAULIC HOSE (4112, 4114) 1/2" X 80" HYDRAULIC HOSE (4116)
8	HYF-2220	ELBOW (1/2"m - 1/2" O-RING)
9	HYF-3220	ADAPTER (1/2"m - 1/2" O-RING)
10	HYO-2103	CYLINDER CLEVIS PIN, 1 X 3-1/2

Item	Part Number	Description
11	HYA-33008	3" X 8" CYLINDER, ASAE
12	HYS-2001	HYDRAULIC HOSE COVER, 110"
13	HYS-2004	HYDRAULIC HOSE COVER, 12"
14	HYO-3021	HYDRAULIC STOP VALVE
15*	HYO-1206	HYDRAULIC CLAMP WELD PLATE, 1/2
16*	HYO-1202	HYDRAULIC CLAMP BODY, 1/2 (3/4 O.D.)
17*	HYO-1204	HYDRAULIC CLAMP COVER, 1/2
18*	HYO-1208	HYDRAULIC CLAMP BOLT, 1/2 (1-3/4)
19	HYF-4002	HYDRAULIC DISCONNECT

* HYO-1201, CONSISTS OF 15, 16, 17, AND 18

Wheel Lift Hydraulics for CB-4220, 4225, 4230 and 4235

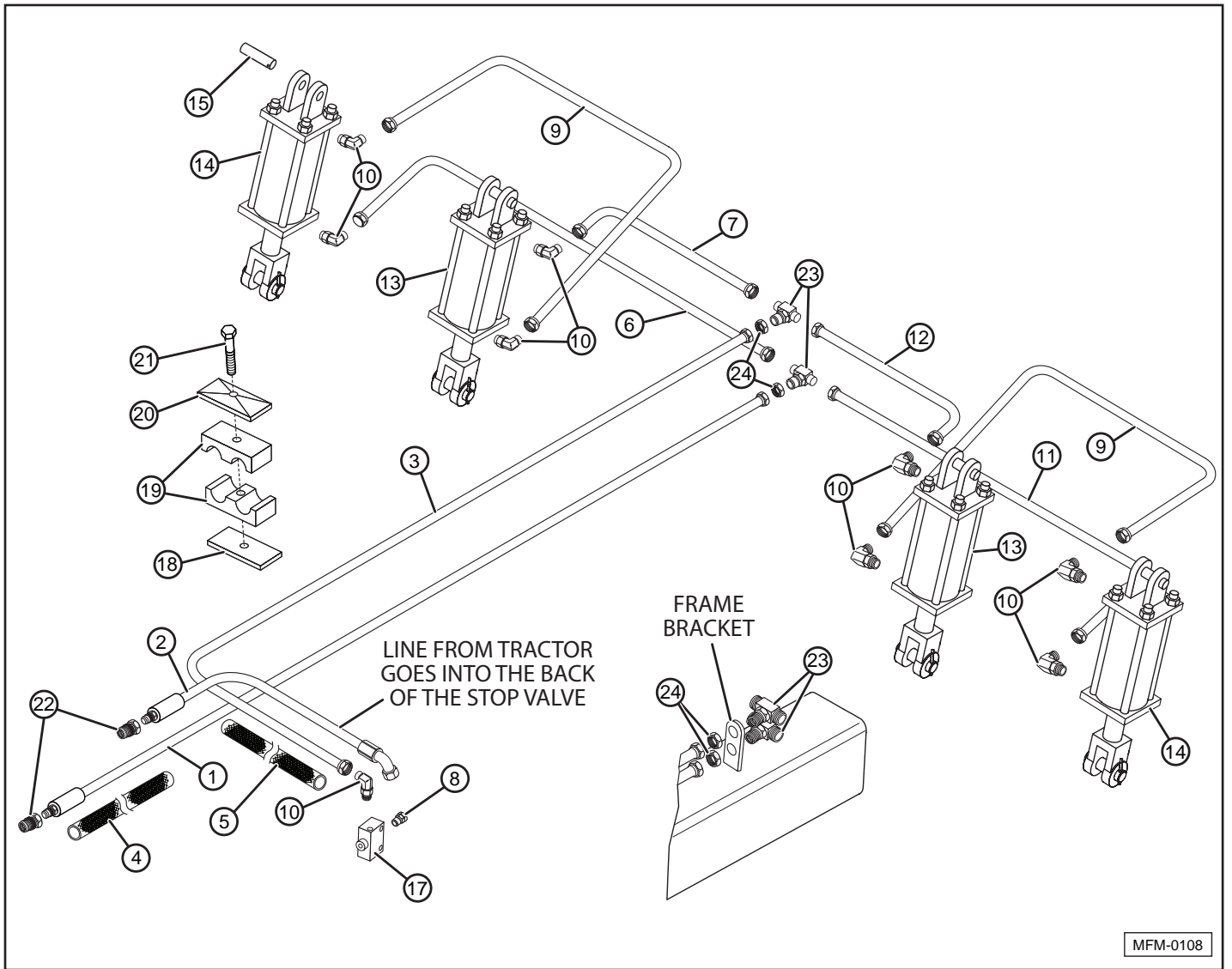

Wheel Lift Hydraulics for CB-4220, 4225, 4230 and 4235 (continued)

Item	Part Number	Description
1	HYH-3236	1/2" X 236" HYDRAULIC HOSE (w/one 1/2" pipe end)
2	HYH-1030	1/2" X 214" HYDRAULIC HOSE (w/one 1/2" pipe end) (CB-4220, 4125, 4130, and 4135)
3	HYH-2074 HYH-2078 HYH-2080	1/2" X 74" HYDRAULIC HOSE (CB-4220) 1/2" X 78" HYDRAULIC HOSE (CB-4225 and CB-4230) 1/2" X 80" HYDRAULIC HOSE (CB-4235)
4	HYS-2001	HYDRAULIC HOSE COVER, 110"
5	HYS-2004	HYDRAULIC HOSE COVER, 12"
6	HYH-2088 HYH-2115 HYH-2136 HYH-2144	1/2" X 88" HYDRAULIC HOSE (CB-4220) 1/2" X 115" HYDRAULIC HOSE (CB-4225) 1/2" X 136" HYDRAULIC HOSE (CB-4230) 1/2" X 144" HYDRAULIC HOSE (CB-4235)
7	HYH-2024 HYH-2030	1/2" X 24" HYDRAULIC HOSE (4120-4130) 1/2" X 30" HYDRAULIC HOSE (4135)
8	HYF-3220	ADAPTER (1/2"m – 1/2" o-ring)
9	HYH-2068 HYH-2094 HYH-2115	1/2" X 68" HYDRAULIC HOSE (CB-4220) 1/2" X 94" HYDRAULIC HOSE (CB-4225) 1/2" X 115" HYDRAULIC HOSE (CB-4230 and CB-4235)
10	HYF-2220	ELBOW (1/2"m – 1/2" O-RING)
11	HYH-2108 HYH-2162 HYH-2182 HYH-2195	1/2" X 108" HYDRAULIC HOSE (CB-4220) 1/2" X 162" HYDRAULIC HOSE (CB-4225) 1/2" X 182" HYDRAULIC HOSE (CB-4230) 1/2" X 195" HYDRAULIC HOSE (CB-4235)
12	HYH-2044 HYH-2070 HYH-2078	1/2" X 44" HYDRAULIC HOSE (4120) 1/2" X 70" HYDRAULIC HOSE (4125, 4130) 1/2" X 78" HYDRAULIC HOSE (4135)

Item	Part Number	Description
13	HYR-4208 DHR 425-8-150	4-1/4" X 8" REPHASING CYLINDER (MONARCH) 4-1/4" X 8" REPHASING CYLINDER (MIDWAY)
14	HYR-4008 DHR-400-8-138	4" X 8" REPHASING CYLINDER (MONARCH) 4" X 8" REPHASING CYLINDER (MIDWAY)
15	HYO-2103	CYLINDER CLEVIS PIN, 1 X 3-1/2
16	HYF-2022	ELBOW (1/2"m – 1/2"f)
17	HYO-3021	HYDRAULIC STOP VALVE
18	HYO-1206	HYDRAULIC CLAMP WELD PLATE, 1/2
19*	HYO-1202	HYDRAULIC CLAMP BODY, 1/2 (3/4" O.D.)
20*	HYO-1204	HYDRAULIC CLAMP COVER, 1/2
21*	HYO-1208	HYDRAULIC CLAMP BOLT, 1/2 (1-3/4)
22*	HYF-4002	HYDRAULIC DISCONNECT
23	HYF-1222	TEE (1/2"m – 1/2"m – 1/2"m)
24	HYO-4002	1/2" TEE NUT
HYDRAULIC CYLINDER SEAL KITS		
	639567	SEAL KIT FOR HYR-4208 CYLINDER (MONARCH)
	4A6104	SEAL KIT FOR DHR 425-8-150 EBSC CYLINDER (MIDWAY)
	639564	SEAL KIT FOR HYR-4008 CYLINDER (MONARCH)
	4A5103	SEAL KIT FOR DHR 400-8-138 EBSC CYLINDER (MIDWAY)

* HYO-1201, CONSISTS OF 19, 20, 21, AND 22

Wheel Lift Hydraulics for CB-4245

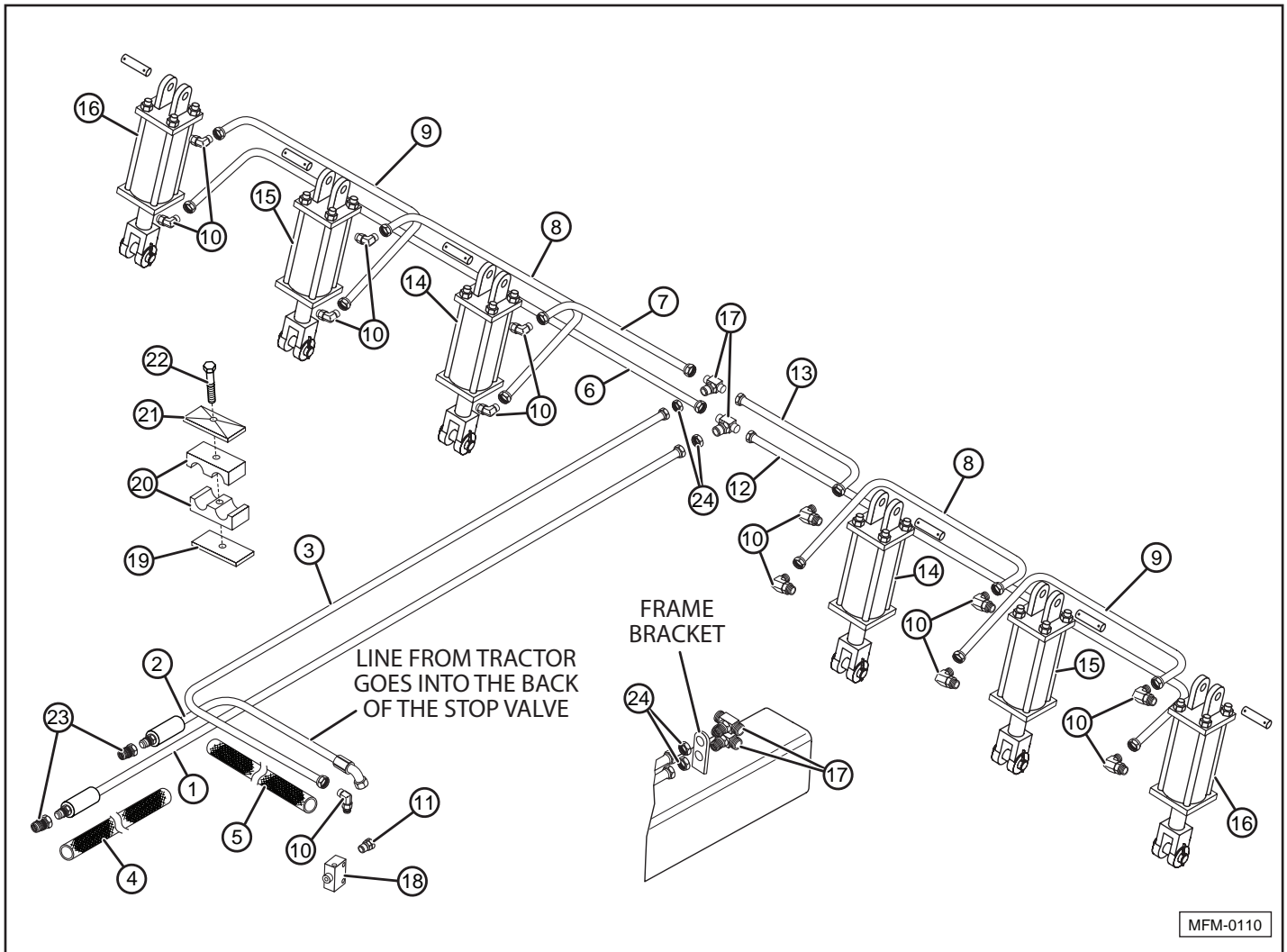

Item	Part Number	Description
1	HYH-3236	1/2" X 236" HYDRAULIC HOSE (w/one 1/2" pipe end)
2	HYH-1030	1/2" X 214" HYDRAULIC HOSE (w/one 1/2" pipe end)
3	HYH-2074	1/2" X 74" HYDRAULIC HOSE
4	HYS-2001	HYDRAULIC HOSE COVER, 110"
5	HYS-2004	HYDRAULIC HOSE COVER, 12"
6	HYH-2255	1/2" X 255" HYDRAULIC HOSE
7	HYH-2030	1/2" X 30" HYDRAULIC HOSE
8	HYF-2128	1/2" X 128" HYDRAULIC HOSE
9	HYH-2104	1/2" X 104" HYDRAULIC HOSE
10	HYF-2220	ELBOW (1/2"m - 1/2" O-RING)
11	HYF-3220	ADAPTER (1/2"m - 1/2" O-RING)
12	HYH-2287	1/2" X 287" HYDRAULIC HOSE
13	HYH-2065	1/2" X 65" HYDRAULIC HOSE
14	HYR-4208 DHR 425-8-150	4-1/4" X 8" REPHASING CYLINDER (MONARCH) 4-1/4" X 8" REPHASING CYLINDER (MIDWAY)
15	HYR-4008 DHR 400-8-138	4" X 8" REPHASING CYLINDER (MONARCH) 4" X 8" REPHASING CYLINDER (MIDWAY)
16	HYR-3808	3-3/4" X 8" REPHASING CYLINDER

Item	Part Number	Description
17	HYF-1222	TEE (1/2"m - 1/2"m - 1/2"m)
18	HYO-3021	HYDRAULIC STOP VALVE
19*	HYO-1206	HYDRAULIC CLAMP WELD PLATE, 1/2
20*	HYO-1202	HYDRAULIC CLAMP BODY, 1/2 (3/4" O.D.)
21*	HYO-1204	HYDRAULIC CLAMP COVER, 1/2
22*	HYO-1208	HYDRAULIC CLAMP BOLT, 1/2 (1-3/4)
23	HYF-4002	HYDRAULIC DISCONNECT
24	HYO-4002	1/2" TEE NUT
HYDRAULIC CYLINDER SEAL KITS		
	639567	SEAL KIT FOR HYR-4208 CYLINDER (MONARCH)
	4A6104	SEAL KIT FOR DHR 425-8-150 EBCS (MIDWAY)
	639564	SEAL KIT FOR HYR-4008 CYLINDER (MONARCH)
	4A5103	SEAL KIT FOR DHR 400-8-138 EBCS (MIDWAY)
	639563	SEAL KIT FOR HYR-3808 CYLINDER (MONARCH)

* HYO-1201, CONSISTS OF 19, 20, 21, AND 22

Wing Fold Hydraulics for CB-4220, 4225 and 4230

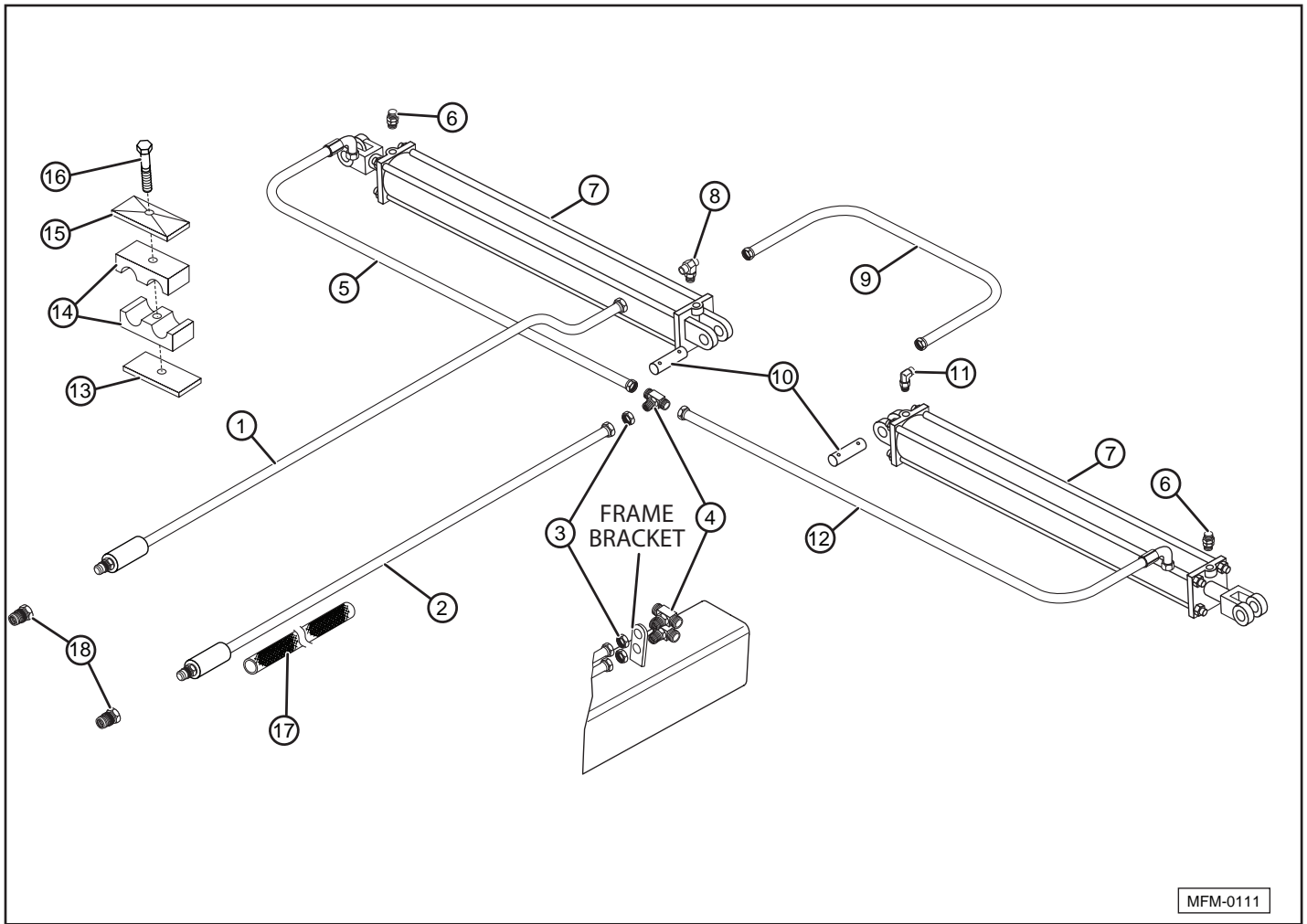

Item	Part Number	Description
1	HYH-3260	1/2" X 260" HYDRAULIC HOSE (w/one 1/2" pipe end)
2	HYH-3250	1/2" X 250" HYDRAULIC HOSE (w/one 1/2" pipe end)
3	HYO-4002	1/2" TEE NUT
4	HYF-1222	TEE (1/2"m - 1/2"m - 1/2"m)
5	HYH-1026	1/2" x 30" HYDRAULIC HOSE
6	10621	HYDRAULIC RESTRICTOR, 1/16"
7	HYC-4030 HYC-4040 HYC-4540	4" x 30" HYDRAULIC CYLINDER (RD-4020) 4" X 40" HYDRAULIC CYLINDER (MONARCH) (RD-4025) 4-1/2" X 40" HYDRAULIC CYLINDER (CB-4230)
8	HYF-1202	TEE (1/2"m - 1/2" O-RING - 1/2"m)
9	HYH-2024 HYH-2030	1/2" x 24" HYDRAULIC HOSE (RD-4020) 1/2" x 30" HYDRAULIC HOSE (RD-4025 and RD-4030)
10	HYO-2123	CYLINDER CLEVIS PIN, 1-1/4 X 3-1/2

Item	Part Number	Description
11	HYF-2220	ELBOW (1/2"m - 1/2" O-RING)
12	HYH-1017 HYH-1025	1/2" X 52" HYDRAULIC HOSE (RD-4020) 1/2" x 70" HYDRAULIC HOSE (RD-4025 and RD-4030)
13*	HYH-1027	HYDRAULIC CLAMP WELD PLATE, 1/2
14*	HYH-1025	HYDRAULIC CLAMP BODY, 1/2 (3/4" O.D.)
15*	HYO-1204	HYDRAULIC CLAMP COVER, 1/2
16*	HYO-1208	HYDRAULIC CLAMP BOLT, 1/2 (1-3/4)
17	HYS-2001	HYDRAULIC HOSE COVER, 110"
18	HYF-4002	HYDRAULIC DISCONNECT

* HYO-1201, CONSISTS OF 13, 14, 15, AND 16

Wing Fold Hydraulics for CB-4235

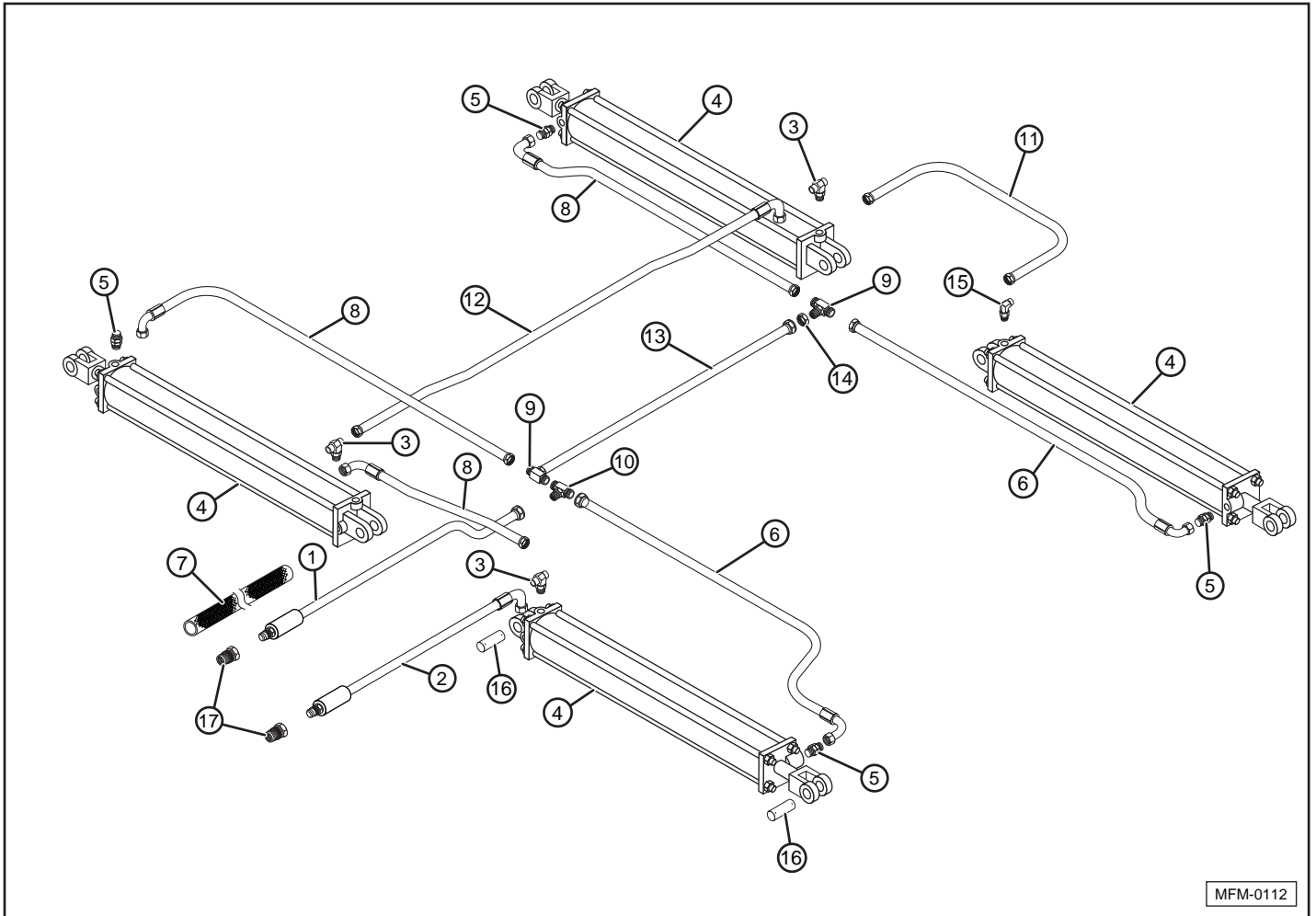

Item	Part Number	Description
1	HYH-3174	1/2" X 174" HYDRAULIC HOSE (w/one 1/2" pipe end)
2	HYH-1031	1/2" X 216" HYDRAULIC HOSE (w/one 1/2" pipe end)
3	HYF-1202	TEE (1/2"m – 1/2" O-RING - 1/2"m)
4	HYC-4040	4" X 40" HYDRAULIC CYLINDER (MONARCH)
5	10621	HYDRAULIC RESTRICTOR, 1/16"
6	HYH-1028	1/2" X 84" HYDRAULIC HOSE
7	HYS-2001	HYDRAULIC HOSE COVER, 110"
8	HYH-1024	1/2" X 38" HYDRAULIC HOSE
9	HYF-1222	TEE (1/2" m – 1/2" m – 1/2"m)
10	HYF-1223	TEE (1/2" m – 1/2" m – 1/2"F)
11	HYH-2040	1/2" X 40" HYDRAULIC HOSE

Item	Part Number	Description
12	HYH-1025	1/2" x 70" HYDRAULIC HOSE
13	HYH-2074	1/2" x 74" HYDRAULIC HOSE
14	HYO-4002	1/2" TEE NUT
15	HYF-2220	ELBOW (1/2"m – 1/2" O-RING)
16	HYO-2123	CYLINDER CLEVIS PIN, 1-1/4 X 3 – 3 1/2
17	HYF-4002	HYDRAULIC DISCONNECT

Wing Fold Hydraulics for CB-4245

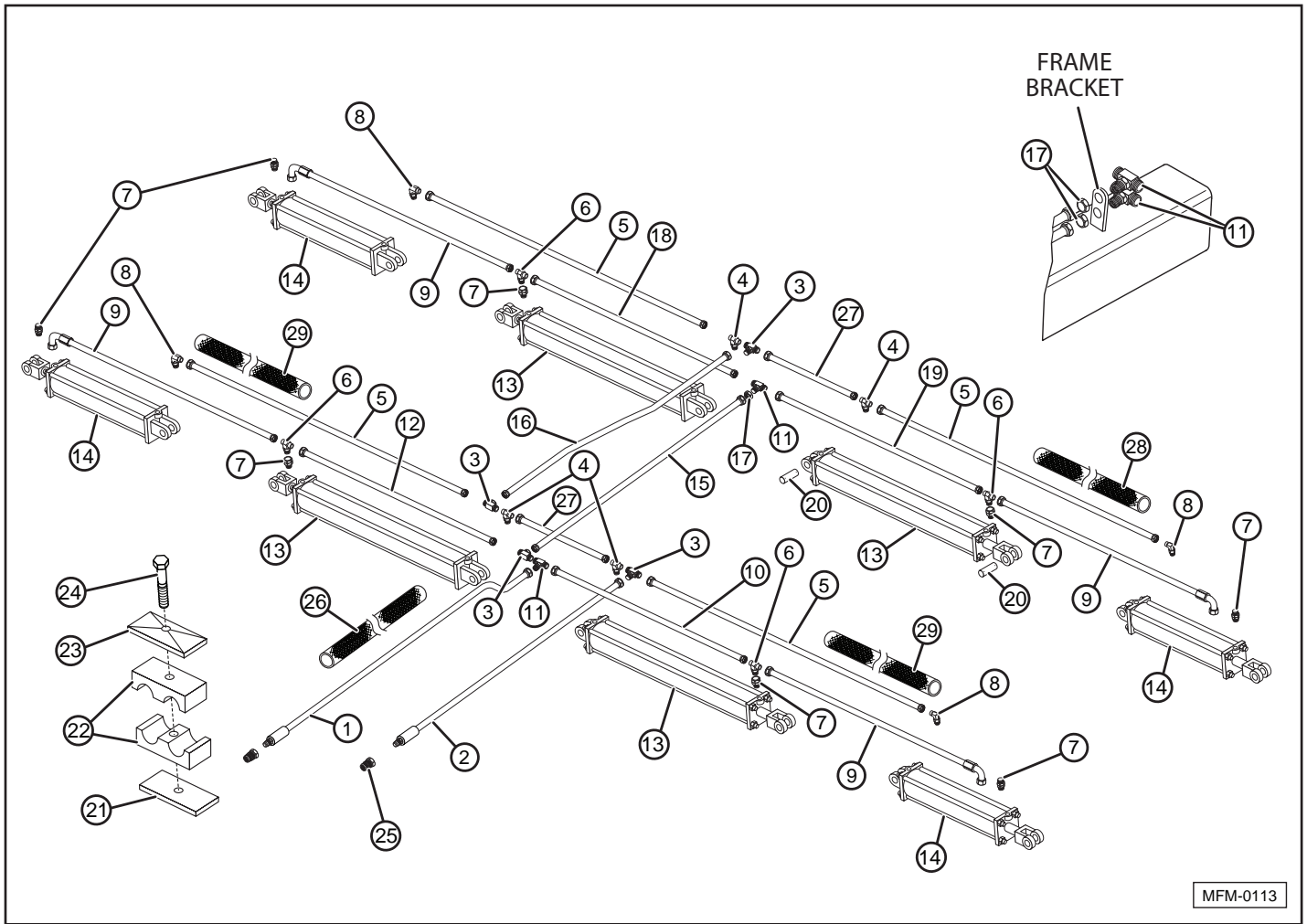

Item	Part Number	Description
1	HYH-3194	1/2" X 194" HYDRAULIC HOSE (w/one 1/2" pipe end)
2	HYH-3216	1/2" X 216" HYDRAULIC HOSE (w/one 1/2" pipe end)
3	HYF-1223	TEE (1/2"m - 1/2"m - 1/2"f)
4	HYF-1202	TEE (1/2"m - 1/2" O-RING - 1/2"m)
5	HYH-2128	1/2" x 128" HYDRAULIC HOSE
6	HYF-1232	TEE (1/2"m - 1/2"f - 1/2"m)
7	10621	HYDRAULIC RESTRICTOR, 1/16"
8	HYF-2220	ELBOW (1/2"m - 1/2" O-RING)
9	HYH-1029	1/2" x 115" HYDRAULIC HOSE
10	HYH-2074	1/2" x 74" HYDRAULIC HOSE
11	HYF-1222	TEE (1/2"m - 1/2"m - 1/2"m)
12	HYH-2055	1/2" x 55" HYDRAULIC HOSE
13	HYC-4036	4" X 36" HYDRAULIC CYLINDER
14	HYC-40 24	4" X 24" HYDRAULIC CYLINDER
15	HYH-2060	1/2" x 60" HYDRAULIC HOSE
16	HYH-2065	1/2" x 65" HYDRAULIC HOSE
17	HYO-4002	1/2" TEE NUT

Item	Part Number	Description
18	HYH-2050	1/2" x 50" HYDRAULIC HOSE
19	HYH-2084	1/2" x 84" HYDRAULIC HOSE
20	HYO-2123	CYLINDER CLEVIS PIN, 1-1/4 X 3-1/2
21*	HYO-1206	HYDRAULIC CLAMP WELD PLATE, 1/2
22*	HYO-1202	HYDRAULIC CLAMP BODY, 1/2 (3/4" O.D.)
23*	HYO-1204	HYDRAULIC CLAMP COVER, 1/2
24*	HYO-1208	HYDRAULIC CLAMP BOLT, 1/2 (1-3/4)
25	HYF-4002	HYDRAULIC DISCONNECT
26	HYS-2001	HYDRAULIC HOSE COVER, 110"
27	HYH-2052	1/2" x 52" HYDRAULIC HOSE
28	HYS-2002	HYDRAULIC HOSE COVER, 85"

* HYO-1201, CONSISTS OF 21, 22, 23, AND 24

Disk Gang Hydraulics for All Models

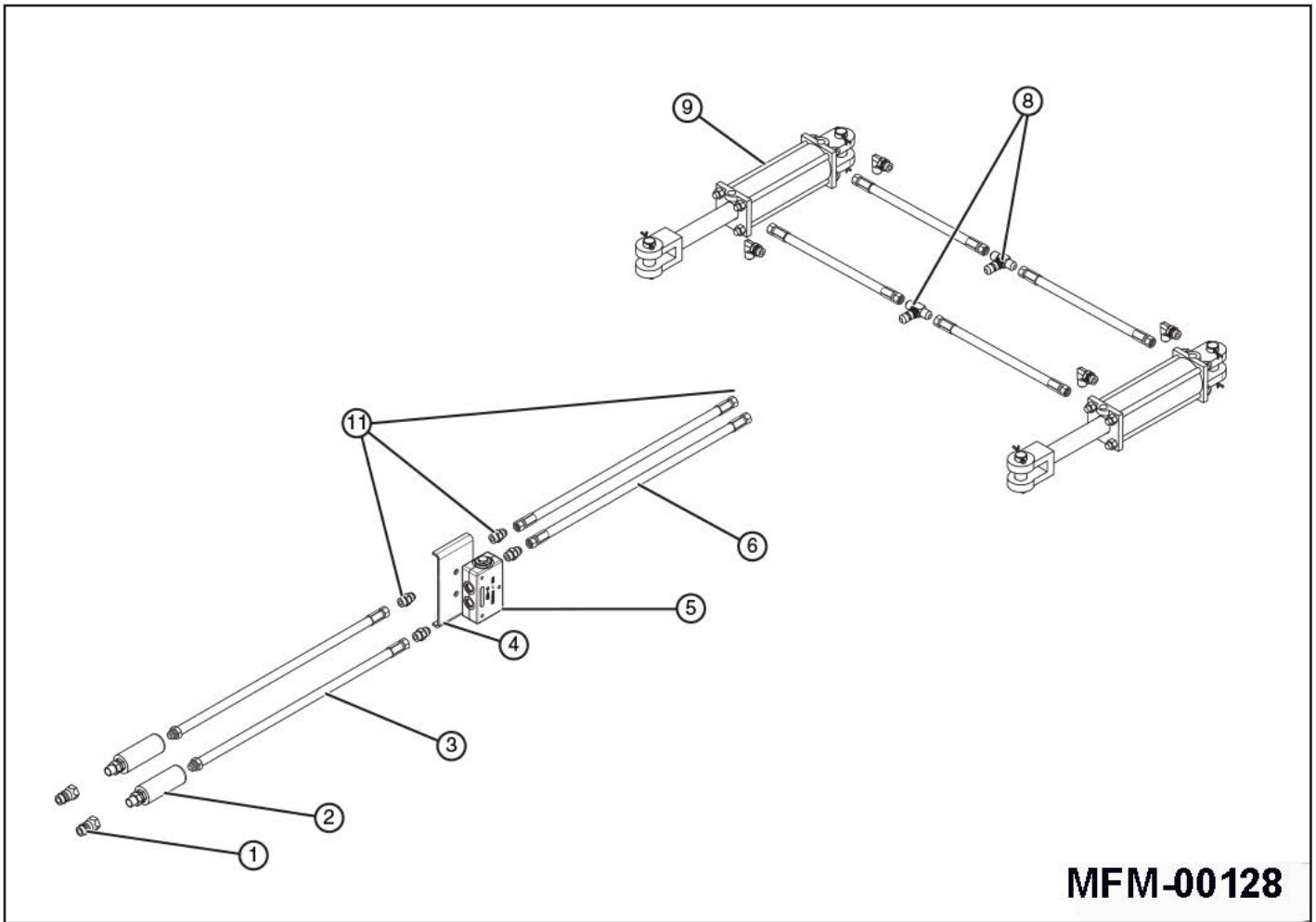

Item	Part Number	Description
1	HYF-4002	HYD DISCONNECT, MALE PIN
2	HYO-1211	HYDRA GRIP W/OUT CLAMSHELL, GREEN
3	HYH-9088	HYD HOSE, 3/8-1/2 PIPE x 88
4	RD-4309	HYDRAULIC HOSE RACK CLAMP
5	14092	HYD LOCK VALVE, SINGLE (PRINCE)
6	HYH-8084	HYD HOSE, 3/8 x 84
7	RD-4924	RELIEF VALVE MOUNT
8	HYF-1888	HYD TEE, 9/16 M - 9/16 M 9/16 M
9	HYC-32008	HYD CYLINDER, 2 x 8
10	HYO-3023	HYDRAULIC RELIEF VALVE
11	HYF-3820	HYD ADAPTER, 3/8M - 1/2 MORB

Disk Gang Hydraulics for CB-4212

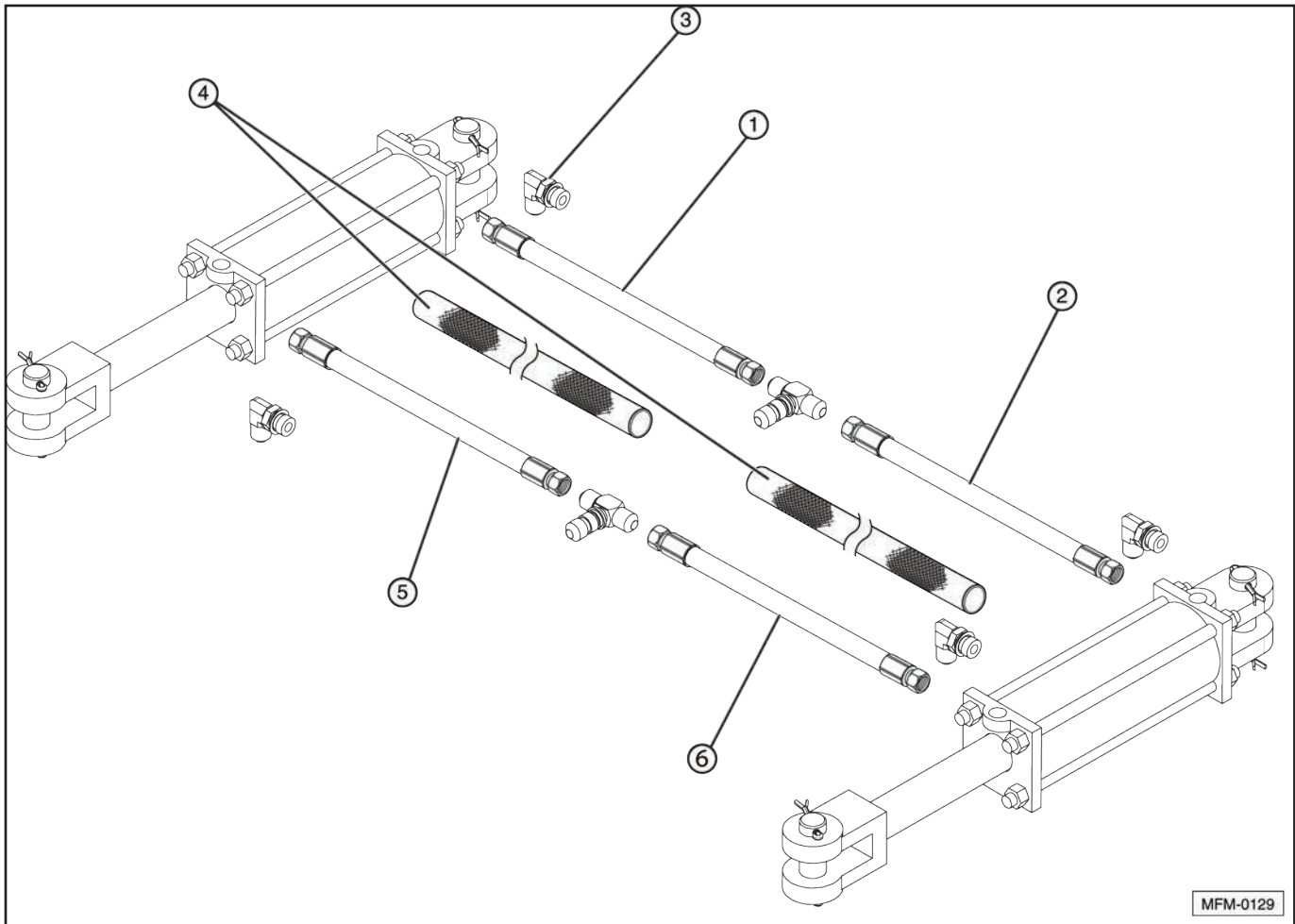

Item	Part Number	Description
1	10801	HYD HOSE, 1/4, 54"
2	10802	HYD HOSE, 1/4, 86"
3	HYF-2820	HYD ELBOW, 9/16M - 3/4MORB
4	HYS-2011	HYD HOSE COVER, 48
5	10985	HYD HOSE, 1/4, 48"
6	10809	HYD HOSE, 1/4, 80"

Disk Gang Hydraulics for CB-4214

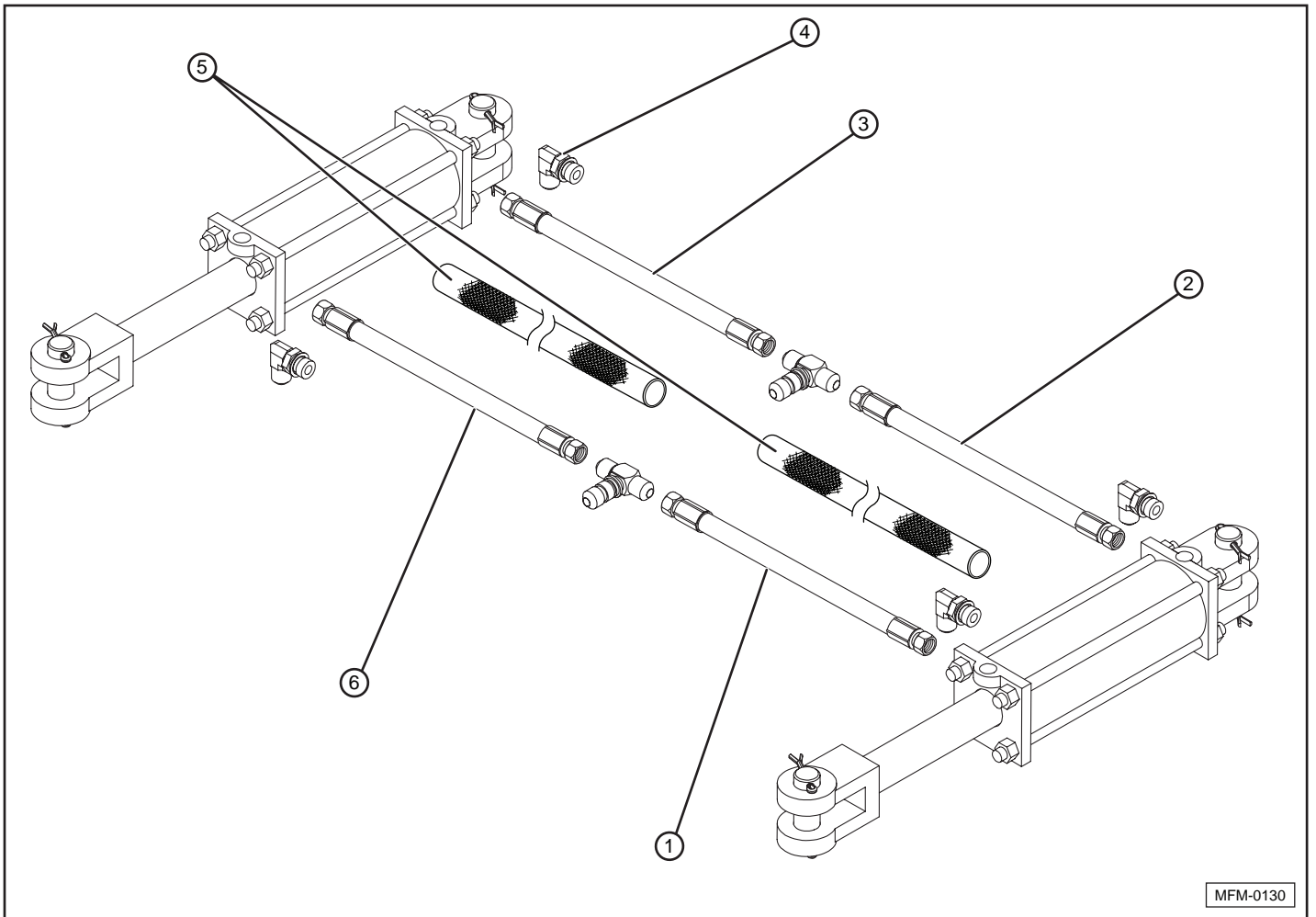

Item	Part Number	Description
1	15019	HYD HOSE, 1/4, 70"
2	10806	HYD HOSE, 1/4, 78"
3	15420	HYD HOSE, 1/4, 44"
4	HYF-2820	HYD ELBOW, 9/16M - 3/4MORB
5	HYS-2011	HYD HOSE COVER, 48
6	10991	HYD HOSE, 1/4, 38"

Disk Gang Hydraulics for CB-4220

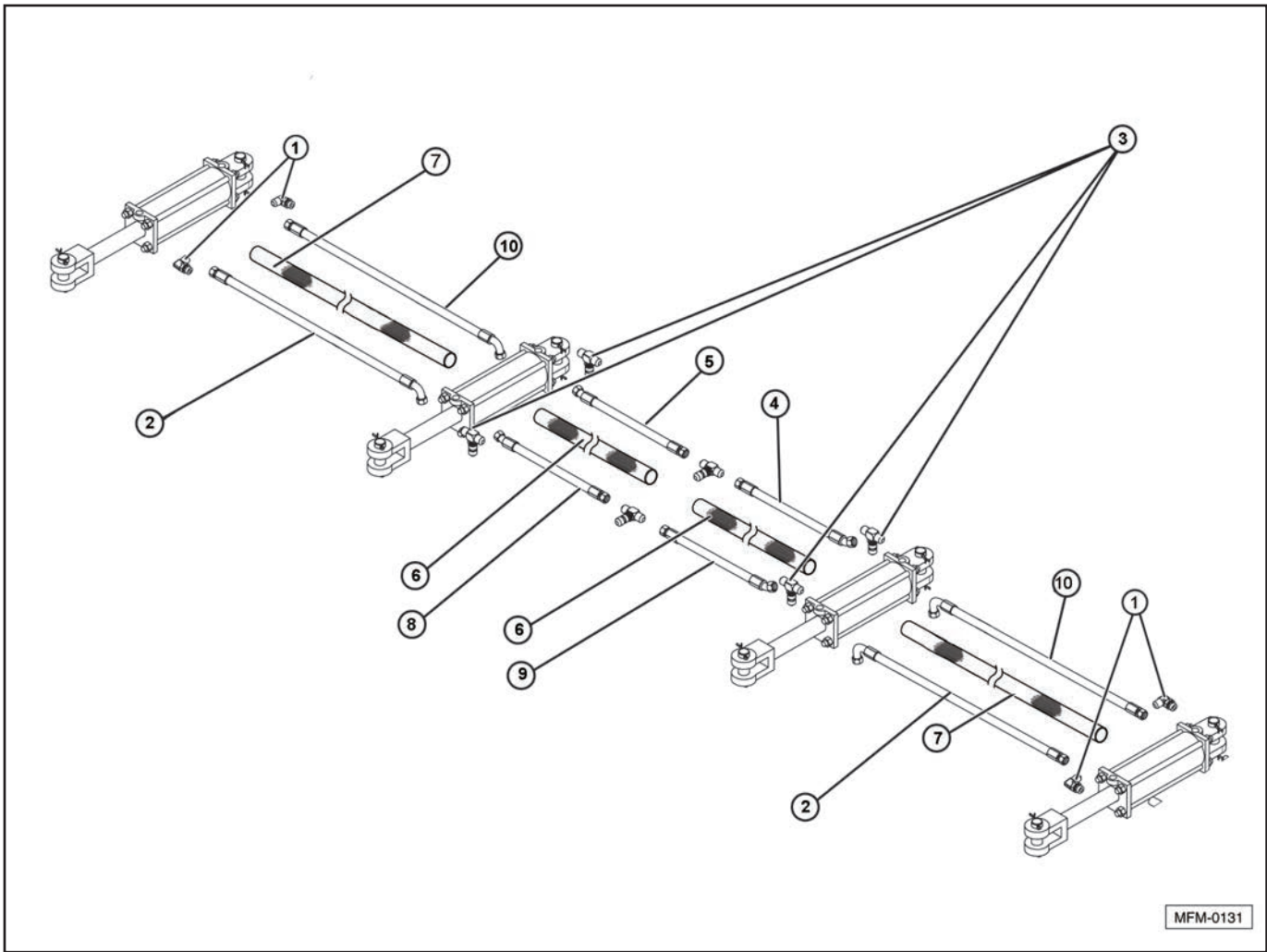

Item	Part Number	Description
1	HYF-2820	HYD ELBOW, 9/16M - 3/4MORB
2	10809	HYD HOSE, 1/4, 80"
3	HYF-1809	HYD TEE, 9/16M - 3/4ORB - 9/16M
4	10800	HYD HOSE, 1/4, 58"
5	10985	HYD HOSE, 1/4, 48"
6	HYS-2011	HYD HOSE COVER, 48
7	HYS-2006	HYD HOSE COVER, 60
8	15421	HYD HOSE, 1/4, 41"
9	10986	HYD HOSE, 1/4, 52"
10	14209	HYD HOSE, 1/4, 72"

Disk Gang Hydraulics for CB-4225

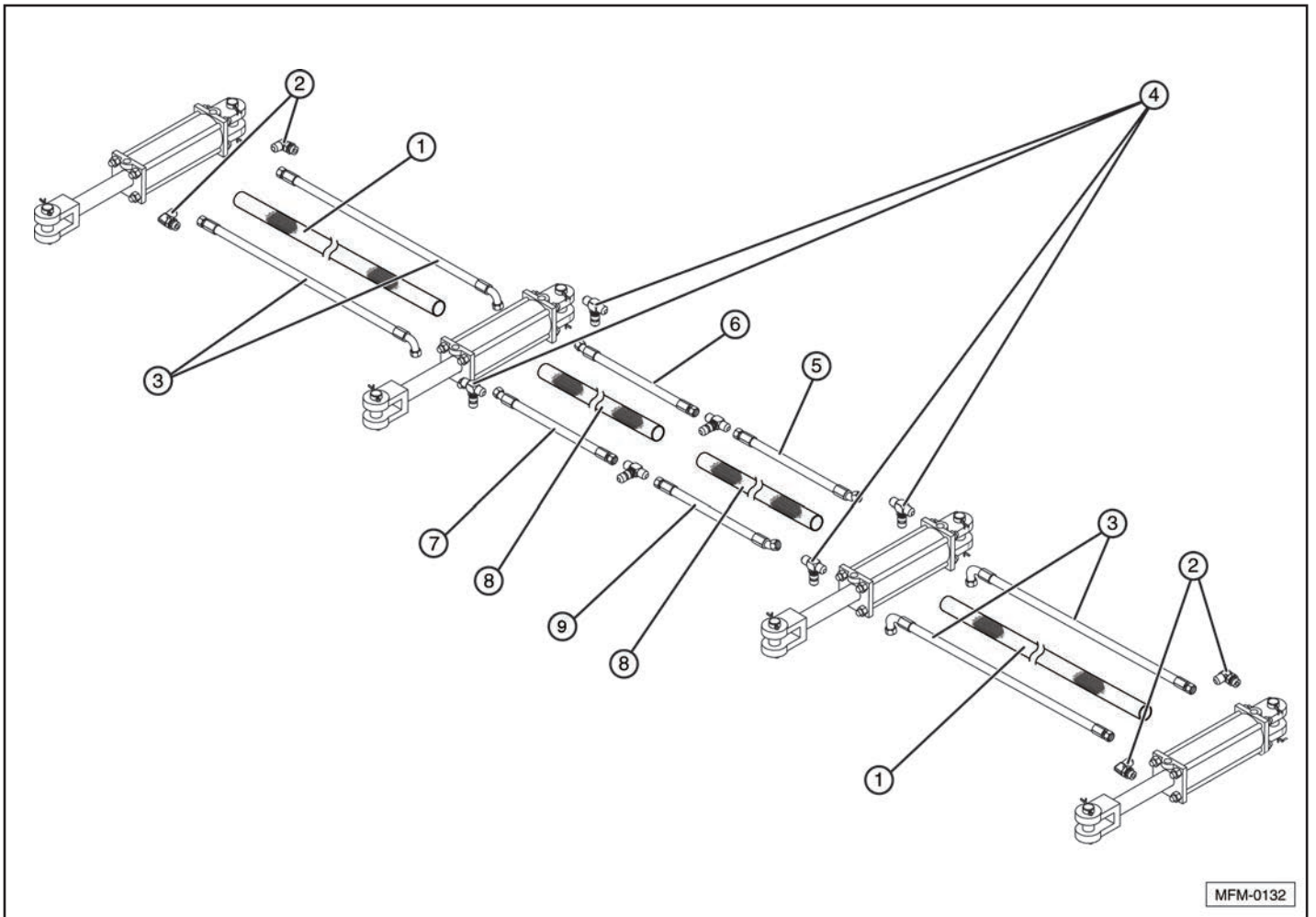

Item	Part Number	Description
1	HYS-2012	HYD HOSE COVER, 80
2	HYF-2820	HYD ELBOW, 9/16M - 3/4MORB
3	10992	HYD HOSE, 1/4, 102"
4	HYF-1809	HYD TEE, 9/16M - 3/4ORB - 9/16M
5	10802	HYD HOSE, 1/4, 86"
6	10801	HYD HOSE, 1/4, 54"
7	10985	HYD HOSE, 1/4, 48
8	HYS-2011	HYD HOSE COVER, 48
9	10809	HYD HOSE, 1/4, 80"

Disk Gang Hydraulics for CB-4230

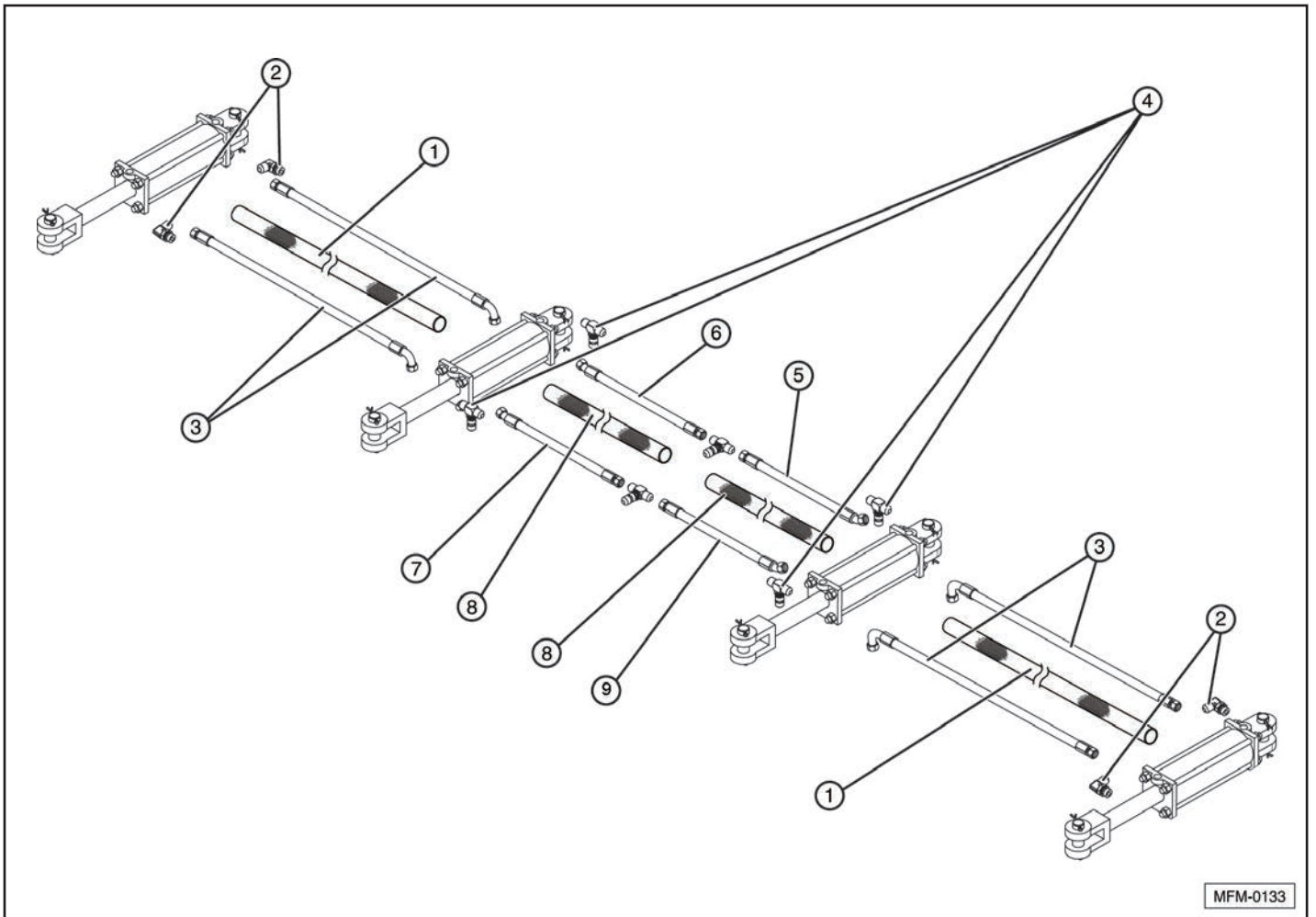

Item	Part Number	Description
1	HYS-2001	HYD HOSE COVER, 110
2	HYF-2820	HYD ELBOW, 9/16M - 3/4MORB
3	10993	HYD HOSE, 1/4, 122"
4	HYF-1809	HYD TEE, 9/16M - 3/4ORB - 9/16M
5	10802	HYD HOSE, 1/4, 86"
6	10801	HYD HOSE, 1/4, 54"
7	10985	HYD HOSE, 1/4, 48"
8	HYS-2011	HYD HOSE COVER, 48
9	10809	HYD HOSE, 1/4, 80"

Disk Gang Hydraulics for CB-4235

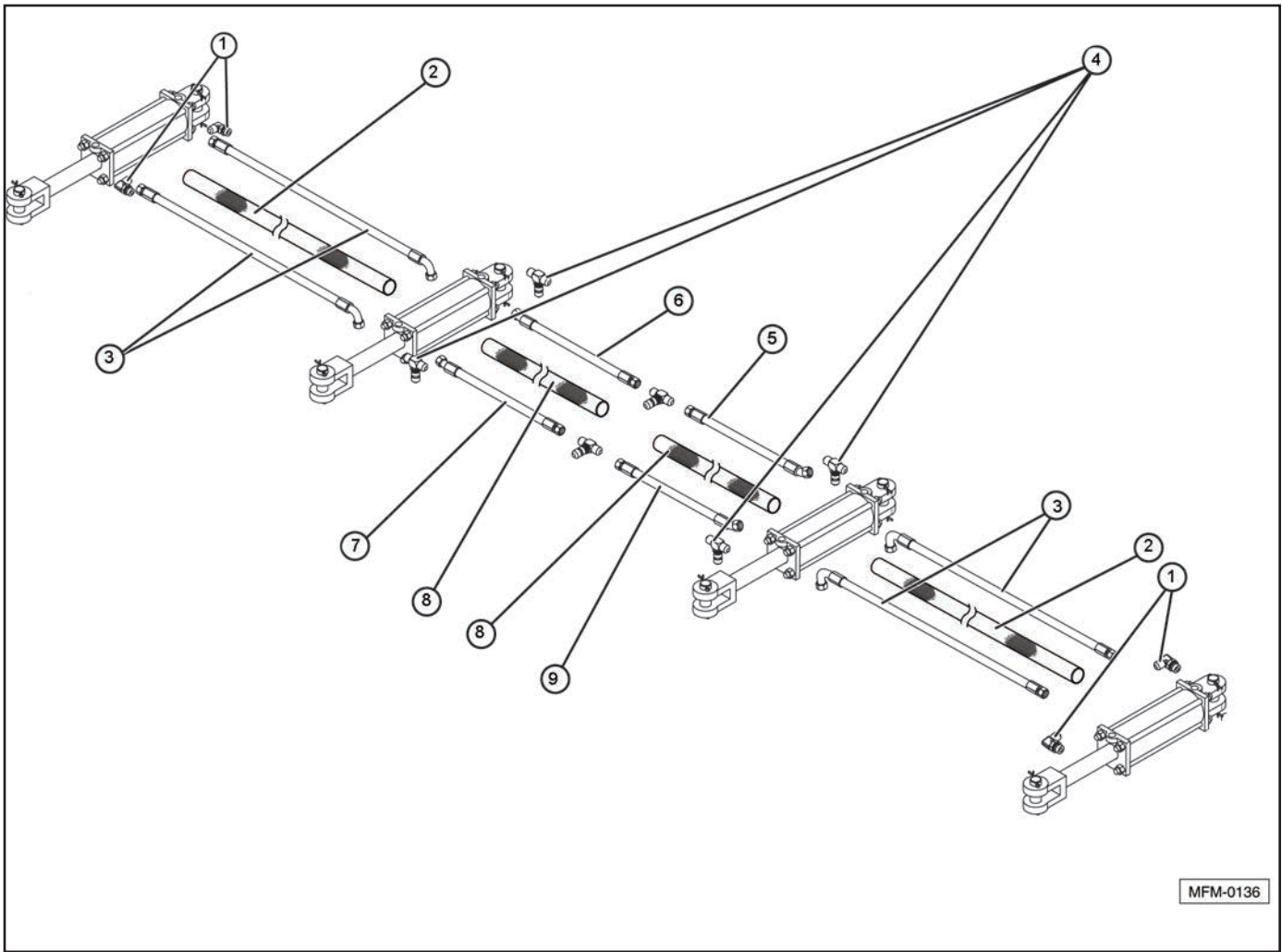

Item	Part Number	Description
1	HYF-2820	HYD ELBOW, 9/16M - 3/4MORB
2	HYS-2009	HYD HOSE COVER, 90
3	10867	HYD HOSE, 1/4, 120"
4	HYF-1809	HYD TEE, 9/16M - 3/4ORB - 9/16M
5	10902	HYD HOSE, 1/4, 98"
6	10988	HYD HOSE, 1/4, 66"
7	14962	HYD HOSE, 1/4, 59"
8	HYS-2006	HYD HOSE COVER, 60
9	10803	HYD HOSE, 1/4, 90"

Disk Gang Hydraulics for CB-4245

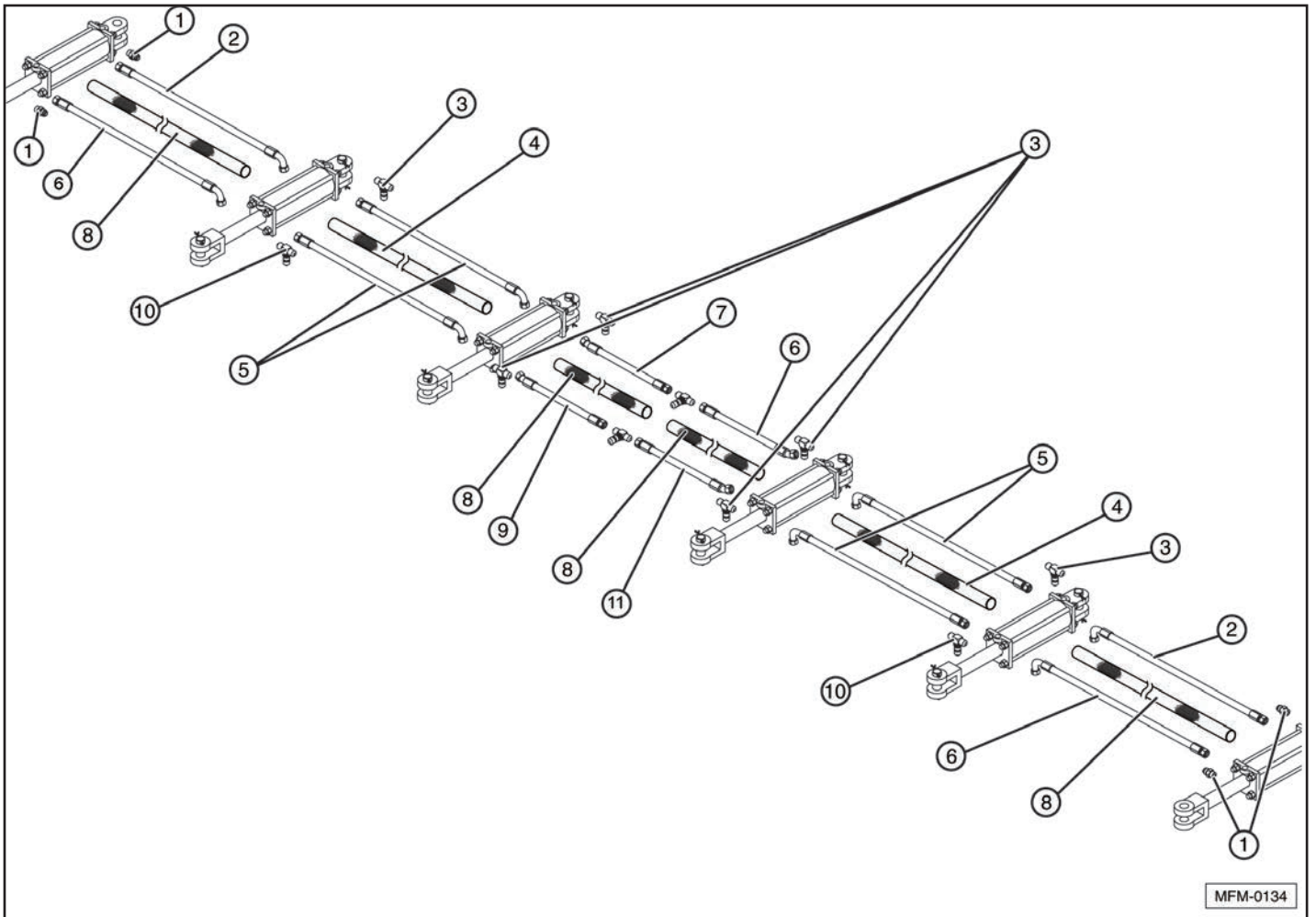

Item	Part Number	Description
1	HYF-2820	HYD ELBOW, 9/16M - 3/4MORB
2	10902	HYD HOSE, 1/4, 98"
3	HYF-1809	HYD TEE, 9/16M - 3/4ORB - 9/16M
4	HYS-2009	HYD HOSE COVER, 90
5	10993	HYD HOSE, 1/4, 122"
6	10902	HYD HOSE, 1/4, 98"
7	10988	HYD HOSE, 1/4, 66"
8	HYS-2006	HYD HOSE COVER, 60
9	14962	HYD HOSE, 1/4, 59"
10	HYF-1089	HYD TEE, 3/8M - 3/8M - 1/2 MORB
11	10803	HYD HOSE, 1/4, 90"

Spur-Till Down Pressure for CB-4212, 4214

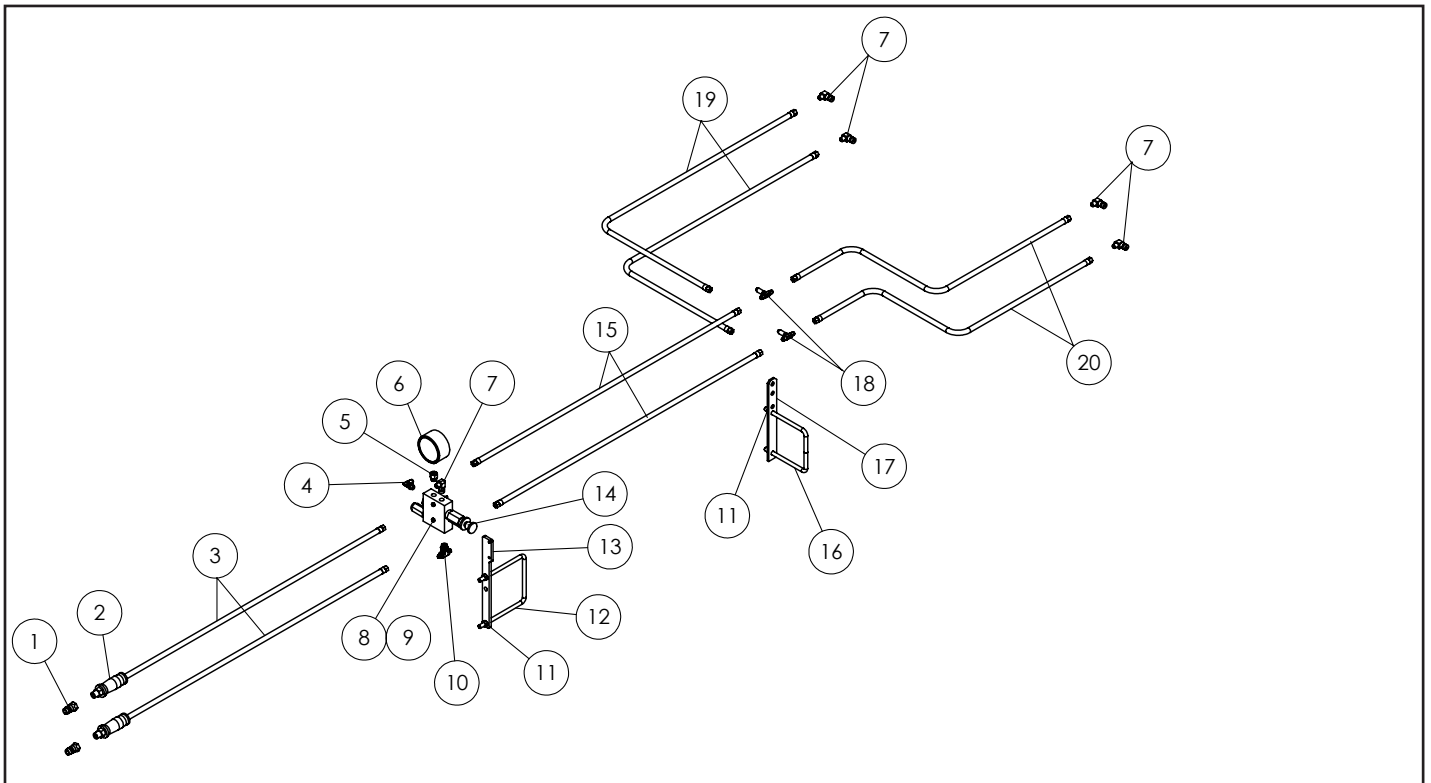

Item	Part Number	Description
1	HYF-4002	HYD DISCONNECT,MALE
2	14459	HYDRA GRIP,GRAY
3	14820	HYD HOSE,1/4(9/16F-1/2PIPE),186
4	HYF-2880	HYD ELBOW,9/16M-9/16Morb
5	14614	HYD ADAPTER,3/4 Morb-1/4 Fpipe
6	14564	PRESSURE GAUGE
7	HYF-2820	HYD ELBOW, 9/16M - 3/4Morb
8	BH-2525	BOLT,HEX,1/4-20X2.5,GD5
9	NLT-2520	NUT, TOP LOCK 1/4-20
10	HYF-1809	HYD TEE,9/16M-3/4Morb-9/16M
11	NLT-5013	NUT,LOCK,TOP,1/2-13
12	BU-1278	U-BOLT, 1/2 x 7 x 8 1/4
13	14919	BRACKET,VALVE MOUNT
14	14909	VALVE,PRESSURE RED. W/REVERSE RELIEF
15	14209	HYD HOSE,1/4(9/16F),72

Item	Part Number	Description
16	BU-1267	U-BOLT, 1/2 x 6 x 7 1/47
17	WDL-2307	CB HYD TEE BRACKET
18	HYF-1888	HYD TEE,9/16M-9/16M-9/16M
19	10809	HYD HOSE,1/4(9/16F),80
20	14209	HYD HOSE,1/4(9/16F),72

Spur-Till Down Pressure CB-4220

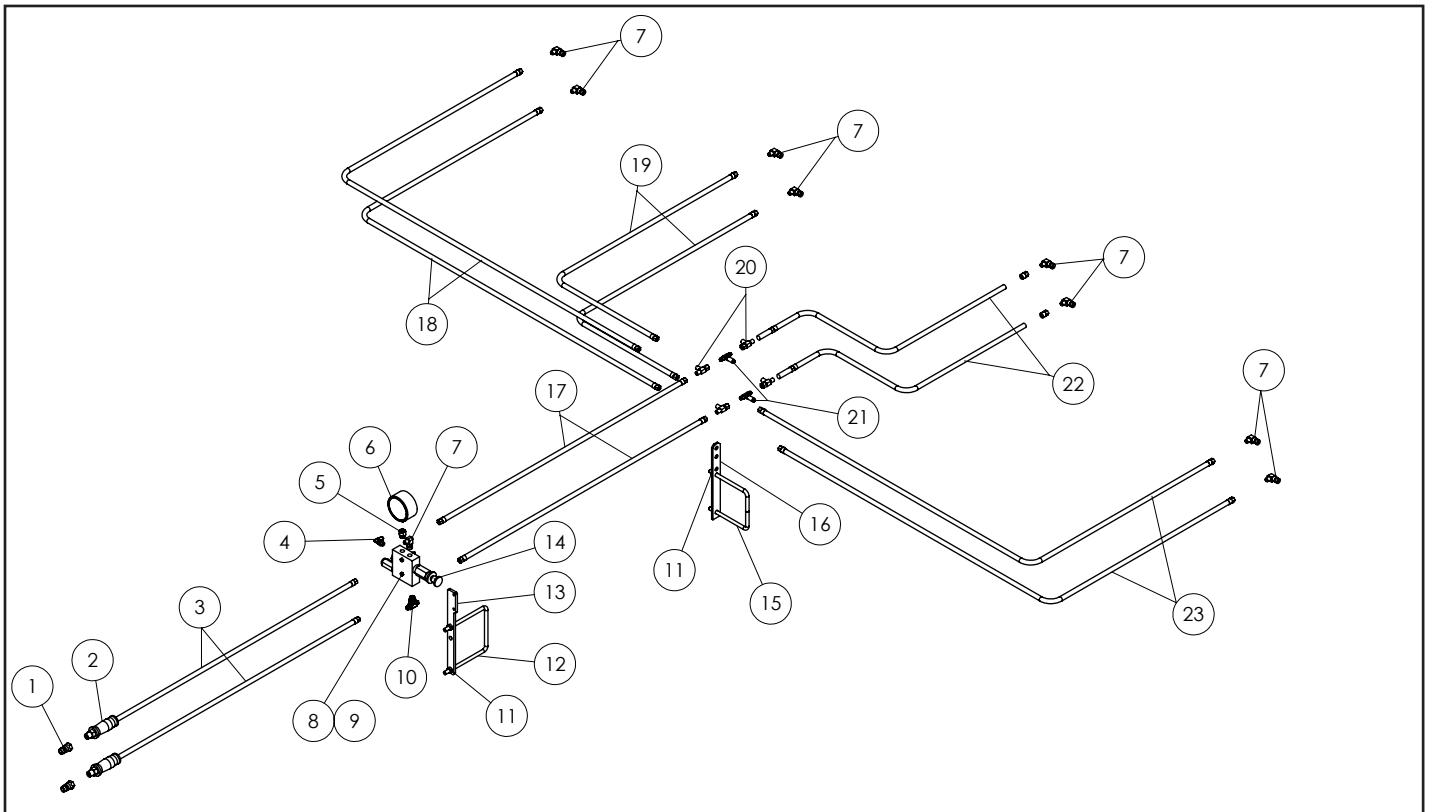

Item	Part Number	Description
1	HYF-4002	HYD DISCONNECT,MALE
2	14459	HYDRA GRIP,GRAY
3	14820	HYD HOSE,1/4(9/16F-1/2PIPE),186
4	HYF-2880	HYD ELBOW,9/16M-9/16Morb
5	14614	HYD ADAPTER,3/4 Morb-1/4 Fpipe
6	14564	PRESSURE GAUGE
7	HYF-2820	HYD ELBOW, 9/16M - 3/4Morb
8	BH-2525	BOLT,HEX,1/4-20X2.5,GD5
9	NLT-2520	NUT, TOP LOCK 1/4-20
10	HYF-1809	HYD TEE,9/16M-3/4Morb-9/16M
11	NLT-5013	NUT,LOCK, TOP,1/2-13
12	BU-1278	U-BOLT, 1/2 x 7 x 8 1/4
13	14919	BRACKET,VALVE MOUNT
14	14909	VALVE,PRESSURE RED. W/REVERSE RELIEF
15	BU-1267	U-BOLT, 1/2 x 6 x 7 1/4
16	WDL-2307	CB HYD TEE BRACKET
17	14209	HYD HOSE,1/4(9/16F),72
18	14210	HYD HOSE,1/4(9/16F),162
19	10809	HYD HOSE,1/4(9/16F),80
20	HYF-1188	HYD TEE,9/16F-9/16M-9/16M
21	HYF-1888	HYD TEE,9/16M-9/16M-9/16M
22	14209	HYD HOSE,1/4(9/16F),72
23	10903	HYD HOSE,1/4(9/16F),156

Spur-Till Down Pressure for CB-4225

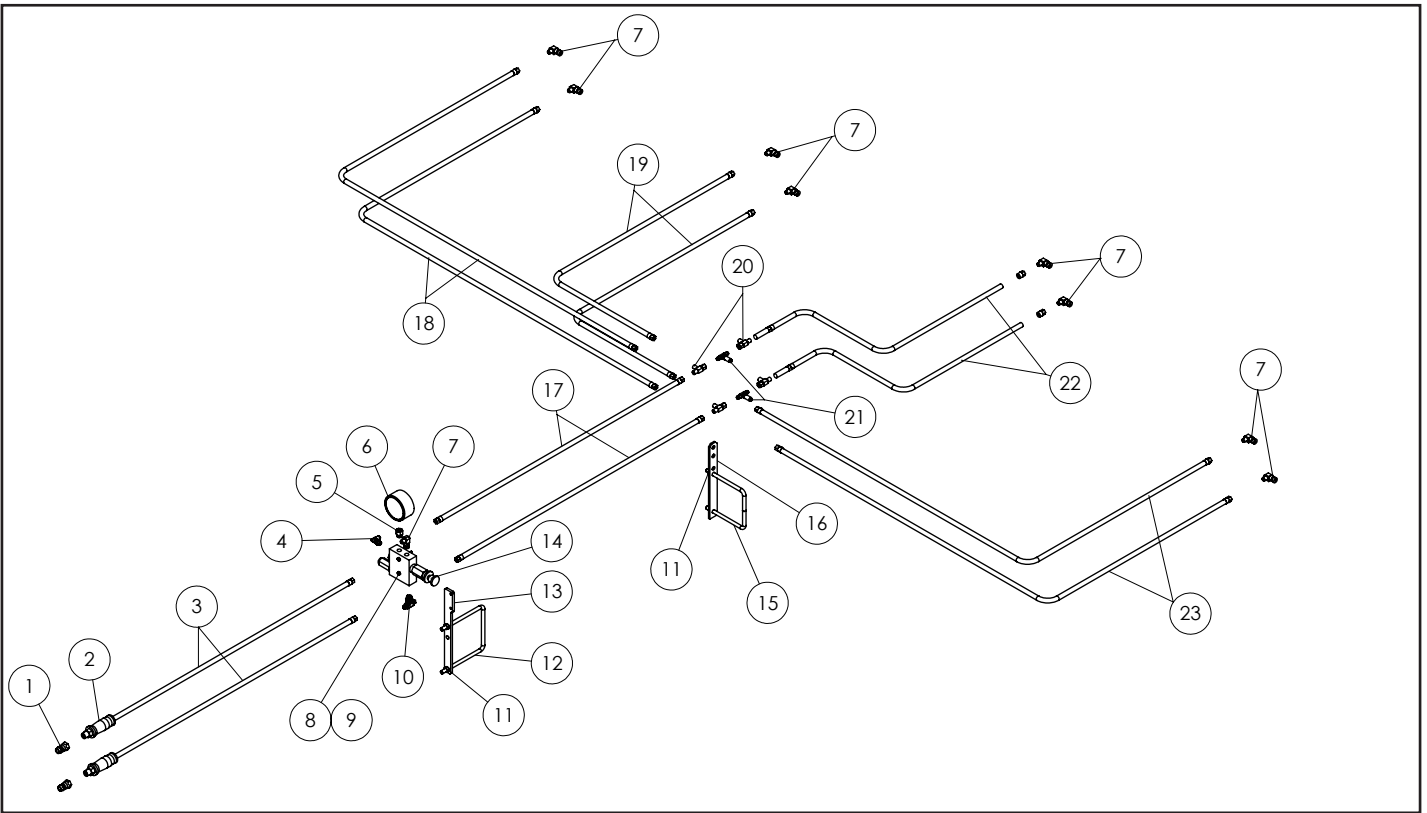

Item	Part Number	Description
1	HYF-4002	HYD DISCONNECT,MALE
2	14459	HYDRA GRIP,GRAY
3	14820	HYD HOSE,1/4(9/16F-1/2PIPE),186
4	HYF-2880	HYD ELBOW,9/16M-9/16Morb
5	14614	HYD ADAPTER,3/4 Morb-1/4 Fpipe
6	14564	PRESSURE GAUGE
7	HYF-2820	HYD ELBOW, 9/16M - 3/4Morb
8	BH-2525	BOLT,HEX,1/4-20X2.5,GD5
9	NLT-2520	NUT, TOP LOCK 1/4-20
10	HYF-1809	HYD TEE,9/16M-3/4Morb-9/16M
11	NLT-5013	NUT,LOCK,TOP,1/2-13
12	BU-1278	U-BOLT, 1/2 x 7 x 8 1/4
13	14919	BRACKET,VALVE MOUNT

Item	Part Number	Description
14	14909	VALVE,PRESSURE RED. W/REVERSE RELIEF
15	BU-1267	U-BOLT, 1/2 x 6 x 7 1/4
16	WDL-2307	CB HYD TEE BRACKET
17	14209	HYD HOSE,1/4(9/16F),72
18	15401	HYD HOSE,1/4(9/16F),204
19	10868	HYD HOSE,1/4(9/16F),110
20	HYF-1188	HYD TEE,9/16F-9/16M-9/16M
21	HYF-1888	HYD TEE,9/16M-9/16M-9/16M
22	14209	HYD HOSE,1/4(9/16F),72
23	14748	HYD HOSE,1/4(9/16F),180

Spur-Till Down Pressure CB-4230

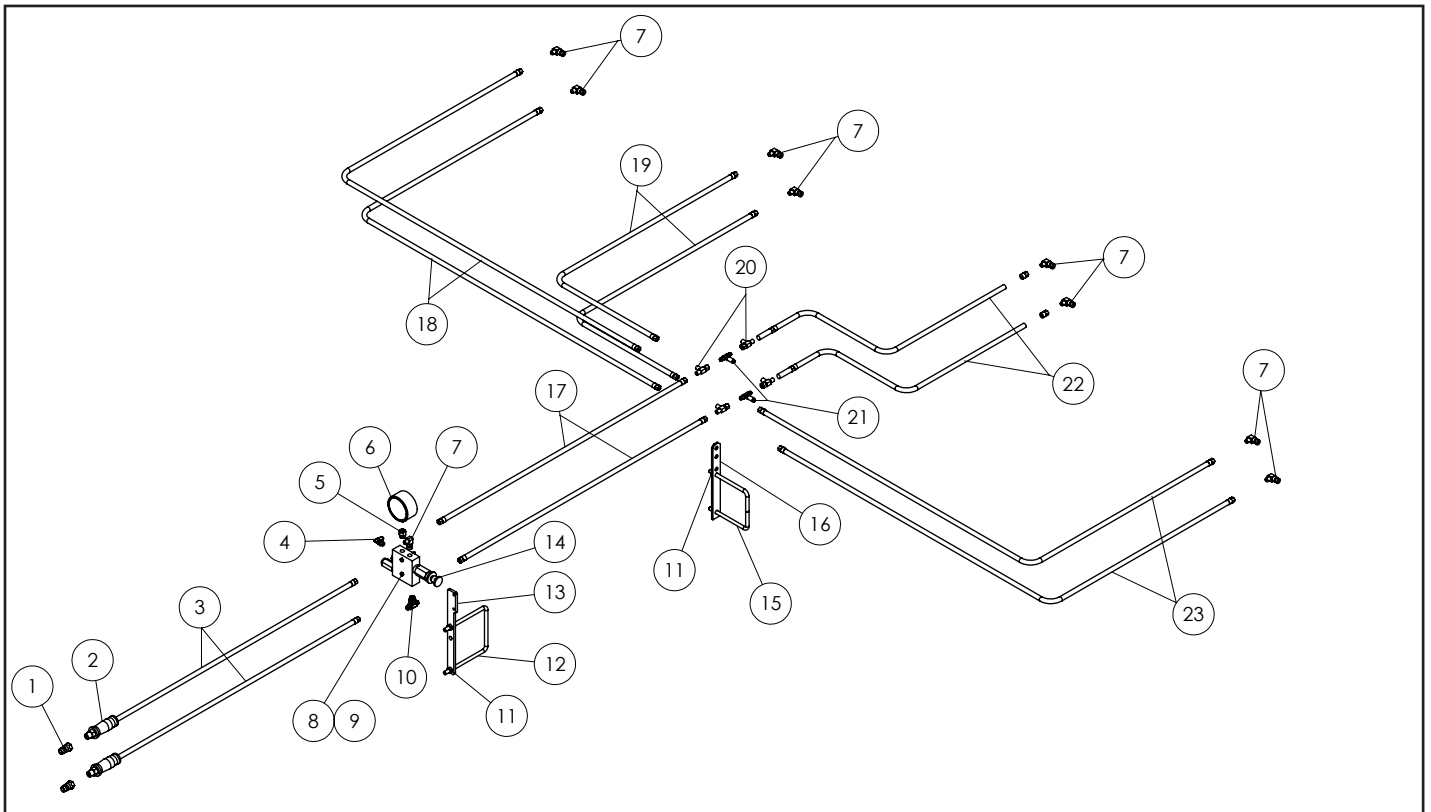

Item	Part Number	Description
1	HYF-4002	HYD DISCONNECT,MALE
2	14459	HYDRA GRIP,GRAY
3	14820	HYD HOSE,1/4(9/16F-1/2PIPE),186
4	HYF-2880	HYD ELBOW,9/16M-9/16Morb
5	14614	HYD ADAPTER,3/4 Morb-1/4 Fpipe
6	14564	PRESSURE GAUGE
7	HYF-2820	HYD ELBOW, 9/16M - 3/4Morb
8	BH-2525	BOLT,HEX,1/4-20X2.5,GD5
9	NLT-2520	NUT, TOP LOCK 1/4-20
10	HYF-1809	HYD TEE,9/16M-3/4Morb-9/16M
11	NLT-5013	NUT,LOCK,TOP,1/2-13
12	BU-1278	U-BOLT, 1/2 x 7 x 8 1/4
13	14919	BRACKET,VALVE MOUNT

Item	Part Number	Description
14	14909	VALVE,PRESSURE RED. W/REVERSE RELIEF
15	BU-1267	U-BOLT, 1/2 x 6 x 7 1/4
16	WDL-2307	CB HYD TEE BRACKET
17	14209	HYD HOSE,1/4(9/16F),72
18	14963	HYD HOSE,1/4(9/16F),215
19	10868	HYD HOSE,1/4(9/16F),110
20	HYF-1188	HYD TEE,9/16F-9/16M-9/16M
21	HYF-1888	HYD TEE,9/16M-9/16M-9/16M
22	14209	HYD HOSE,1/4(9/16F),72
23	14482	HYD HOSE,1/4(9/16F),190

Spur-Till Down Pressure for CB-4235

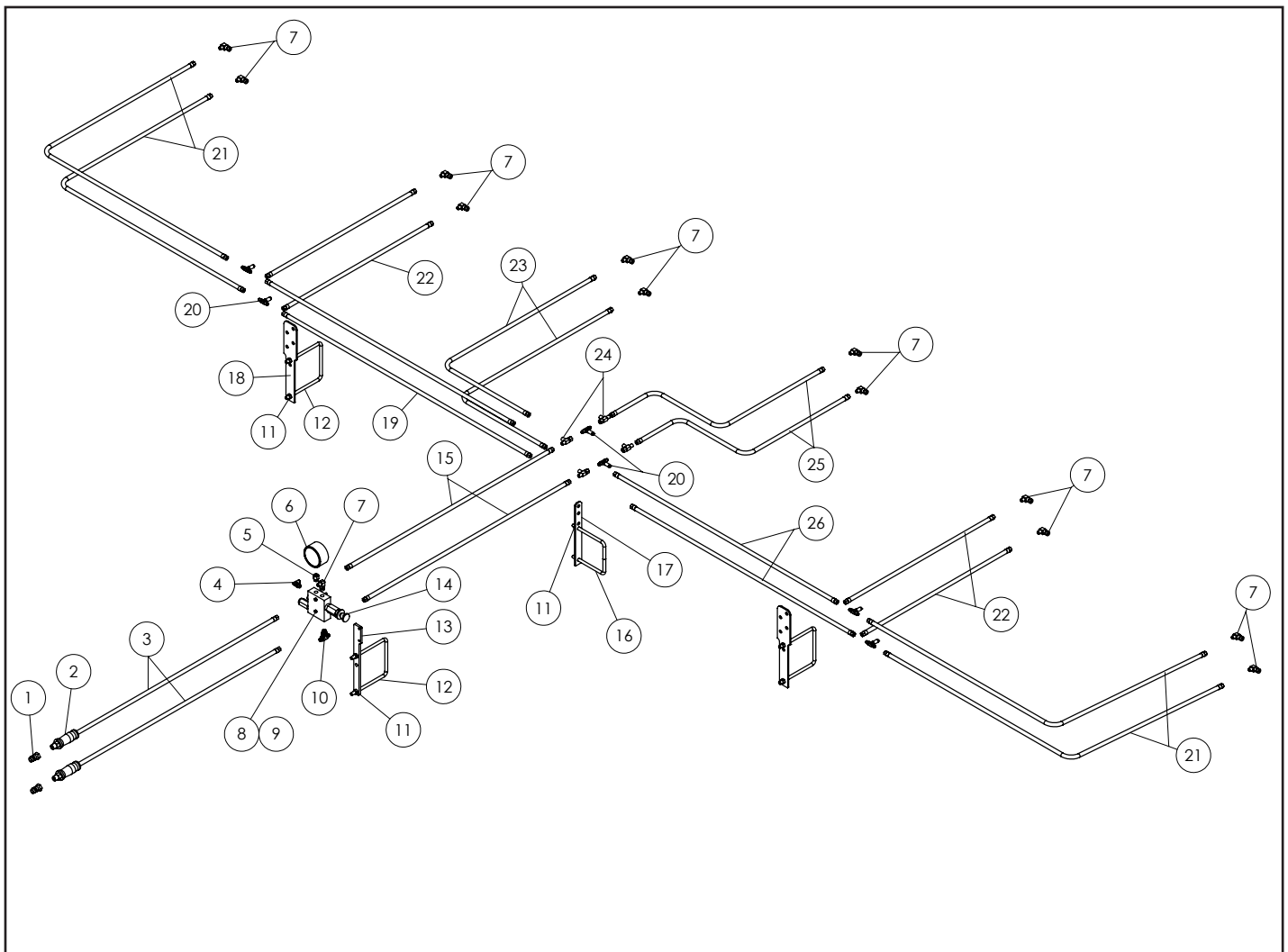

Item	Part Number	Description
1	HYF-4002	HYD DISCONNECT,MALE
2	14459	HYDRA GRIP,GRAY
3	14820	HYD HOSE,1/4(9/16F-1/2PIPE),186
4	HYF-2880	HYD ELBOW,9/16M-9/16Morb
5	14614	HYD ADAPTER,3/4 Morb-1/4 Fpipe
6	14564	PRESSURE GAUGE
7	HYF-2820	HYD ELBOW, 9/16M - 3/4Morb
8	BH-2525	BOLT,HEX,1/4-20X2.5,GD5
9	NLT-2520	NUT, TOP LOCK 1/4-20
10	HYF-1809	HYD TEE,9/16M-3/4Morb-9/16M
11	NLT-5013	NUT,LOCK,TOP,1/2-13
12	BU-1278	U-BOLT, 1/2 x 7 x 8 1/4
13	14919	BRACKET,VALVE MOUNT
14	14909	VALVE,PRESSURE RED. W/REVERSE RELIEF
15	14209	HYD HOSE,1/4(9/16F),72

Item	Part Number	Description
16	BU-1267	U-BOLT, 1/2 x 6 x 7 1/4
17	WDL-2307	CB HYD TEE BRACKET
18	14970	HYDRAULIC TEE HOSE POST
19	10903	HYD HOSE,1/4(9/16F),156
20	HYF-1888	HYD TEE,9/16M-9/16M-9/16M
21	10868	HYD HOSE,1/4(9/16F),110
22	10985	HYD HOSE,1/4(9/16F),48
23	10867	HYD HOSE,1/4(9/16F),120
24	HYF-1188	HYD TEE,9/16F-9/16M-9/16M
25	10806	HYD HOSE,1/4(9/16F),78
26	10992	HYD HOSE,1/4(9/16F),102

Spur-Till Down Pressure for CB-4245

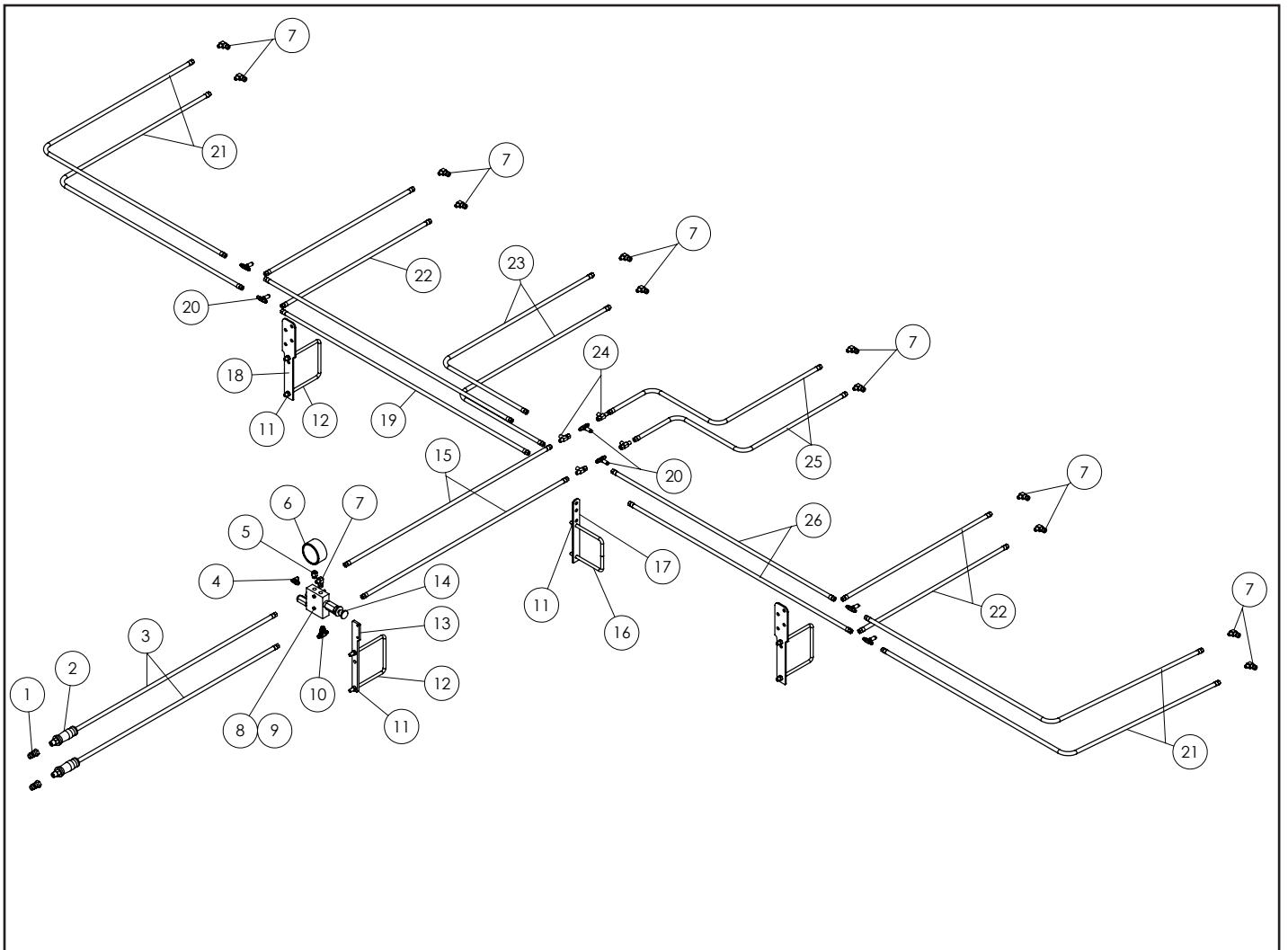

Item	Part Number	Description
1	HYF-4002	HYD DISCONNECT,MALE
2	14459	HYDRA GRIP,GRAY
3	14820	HYD HOSE,1/4(9/16F-1/2PIPE),186
4	HYF-2880	HYD ELBOW,9/16M-9/16Morb
5	14614	HYD ADAPTER,3/4 Morb-1/4 Fpipe
6	14564	PRESSURE GAUGE
7	HYF-2820	HYD ELBOW, 9/16M - 3/4Morb
8	BH-2525	BOLT,HEX,1/4-20X2.5,GD5
9	NLT-2520	NUT, TOP LOCK 1/4-20
10	HYF-1809	HYD TEE,9/16M-3/4Morb-9/16M
11	NLT-5013	NUT,LOCK,TOP,1/2-13
12	BU-1278	U-BOLT, 1/2 x 7 x 8 1/4
13	14919	BRACKET,VALVE MOUNT
14	14909	VALVE,PRESSURE RED. W/REVERSE RELIEF
15	14209	HYD HOSE,1/4(9/16F),72

Item	Part Number	Description
16	BU-1267	U-BOLT, 1/2 x 6 x 7 1/4
17	WDL-2307	CB HYD TEE BRACKET
18	14970	HYDRAULIC TEE HOSE POST
19	10871	HYD HOSE,1/4(9/16F),162
20	HYF-1888	HYD TEE,9/16M-9/16M-9/16M
21	10903	HYD HOSE,1/4(9/16F),156
22	10985	HYD HOSE,1/4(9/16F),48
23	15080	HYD HOSE,1/4(9/16F),130
24	HYF-1188	HYD TEE,9/16F-9/16M-9/16M
25	10989	HYD HOSE,1/4(9/16F),84
26	10993	HYD HOSE,1/4(9/16F),122

Lighting Diagram for CB-4200 Series

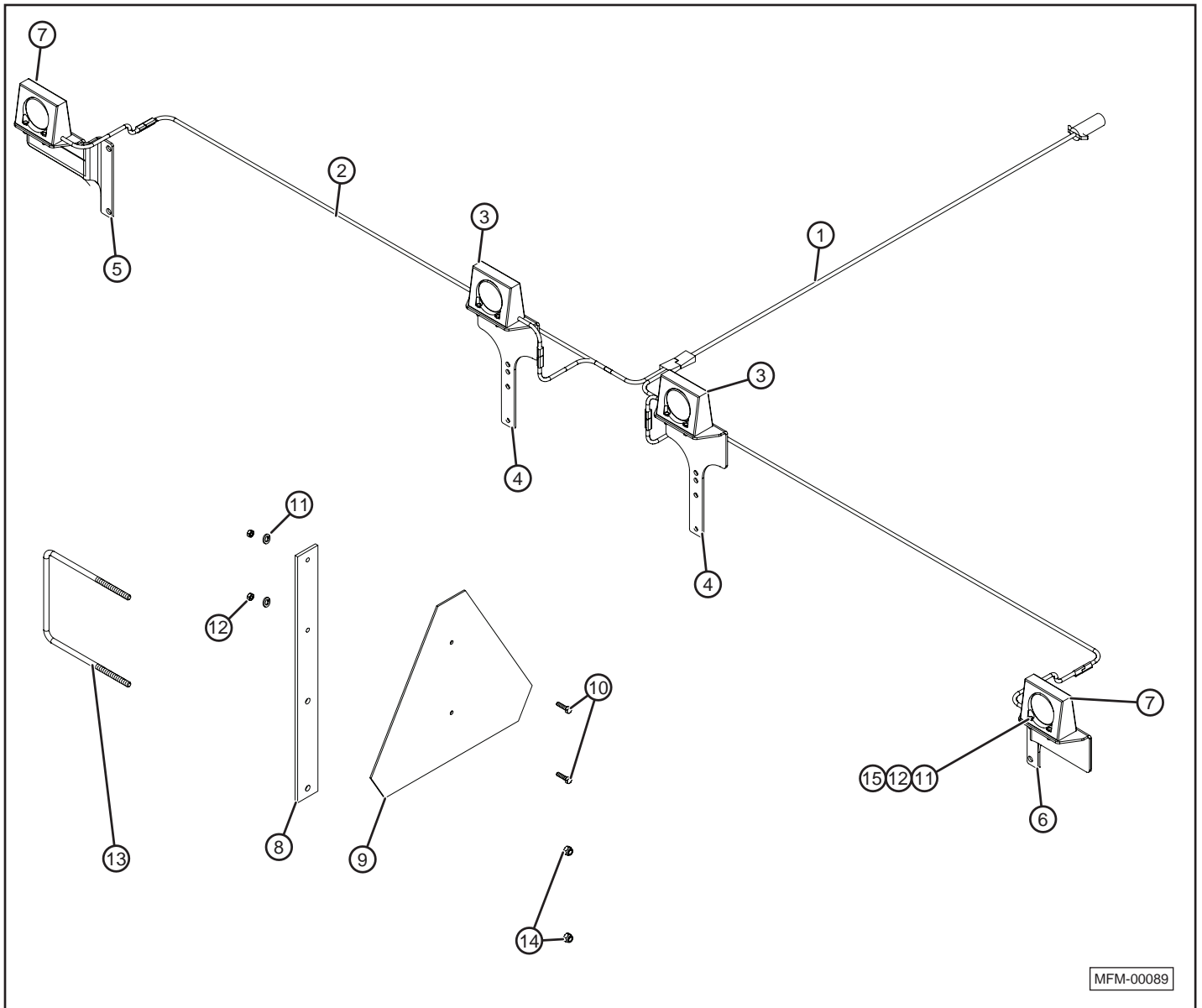

Item	Part Number	Description
1	LB-1320	LIGHT HARNESS, STRAIGHT , 20'
2	LB-1620	LIGHT HARNESS, WISHBONE
3	LB-1107	LIGHT, RED
4	RD-5056	LIGHT MOUNT, SYMMETRICAL
5	RD-5057	LIGHT MOUNT, SINGLE OUTER LT
6	RD-5058	LIGHT MOUNT, SINGLE OUTER RT
7	LB-1106	LIGHT AMBER
8	LB-1203	SMV MOUNT BRACKET

Item	Part Number	Description
9	MM-1300	SMV SIGN
10	BH-2510	1/4-20 x 1 BOLT
11	LW-0025	1/4 LOCK WASHER
12	NH-2520	1/4-20 NUT
13	BU-3878	3/8-16 x 7 x 8 U-BOLT
14	NLT-3816	3/8-16 NUT, TOP LOCK
15	BH-2513	1/4-20 x 1-1/4 BOLT

Hub Components for HD-1371

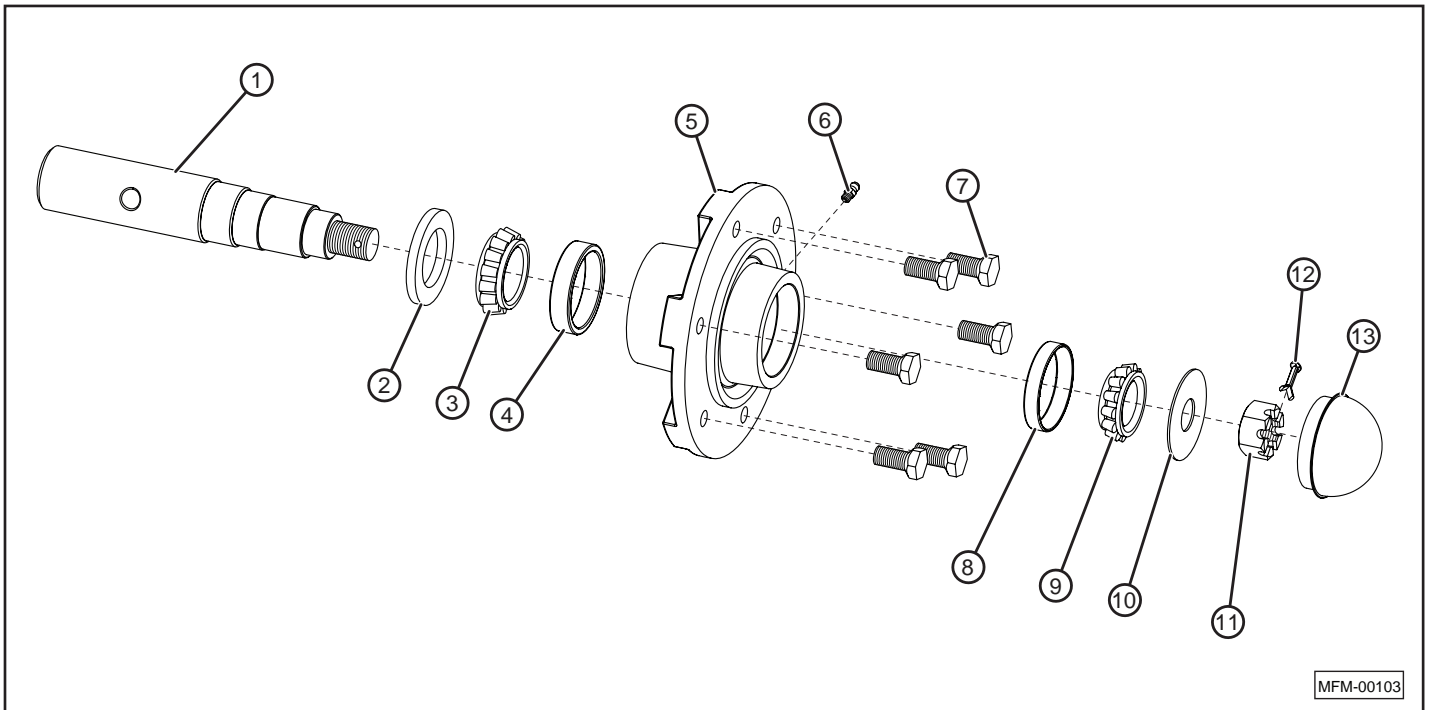

Item	Part Number	Description
6-HOLE HUB, 3560 LB		
1	WDL-2505	SPINDLE, 1-3/4 X 9-1/2
2	HD-1360	GREASE SEAL, 6 HOLE HUB
3	HD-1362	INNER BEARING
4	HD-1366	INNER RACE
5	HD-1361	HUB WITH RACES, 6 HOLE HUB
6	GZ-0601	GREASE ZERK
7	WB-5010	WHEEL BOLTS, 1/2-20 X 1-3/4

Item	Part Number	Description
8	HD-1171	OUTER RACE
9	HD-1363	OUTER BEARING
10	HD-1364	SPINDLE FLAT WASHER, 15/16
11	HD-1365	SPINDLE HEX CASTLE N UT, 7/8-14
12	CP-1517	COTTER PIN (0.150 X 1-3/4)
13	HD-1367	DUST CAP
—	HD-1371	6-HOLE HUB ASSEMBLY (Includes items 2,3,7,9 ,15)

Hub Components for RT-2171

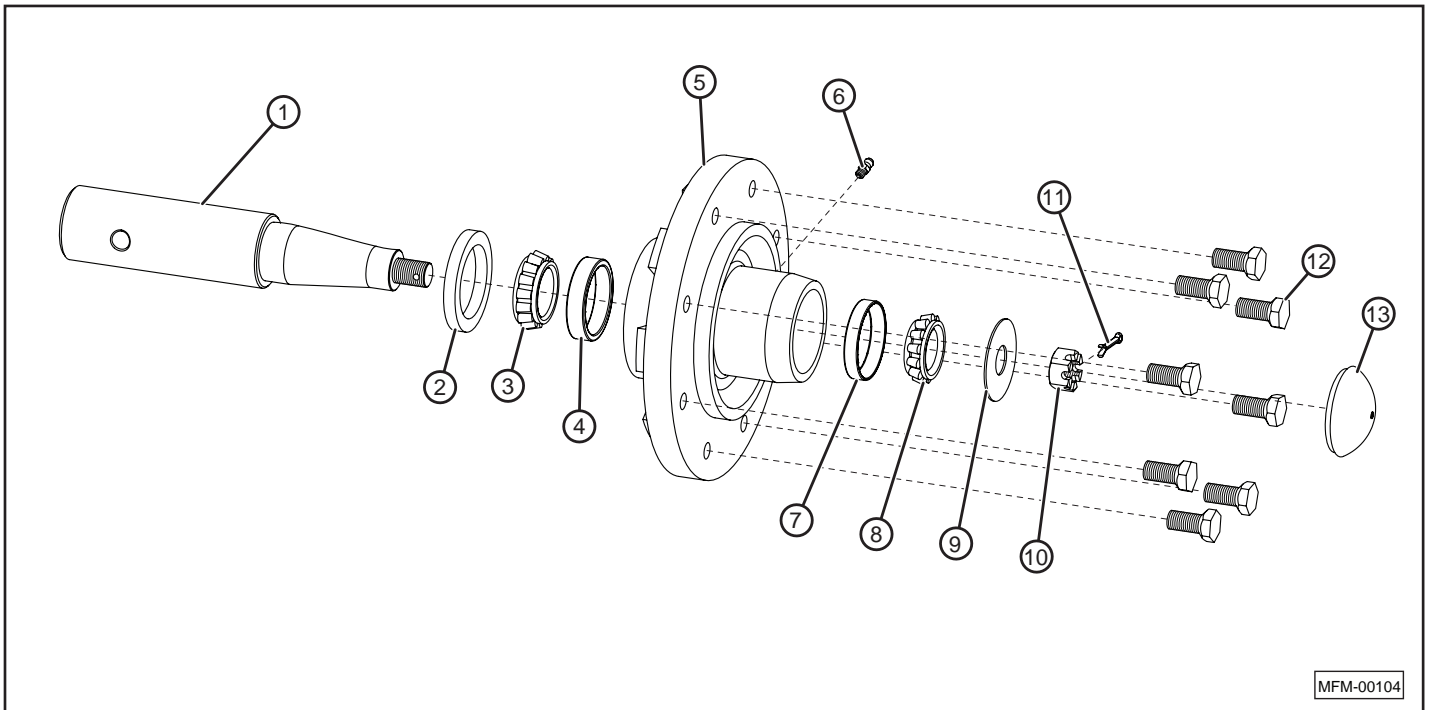

Item	Part Number	Description
8-HOLE HUB, 4500 LB		
1	RT-2170	SPINDLE, 2-1/4 X 11-1/2
2	RT-2172	GREASE SEAL, 8 HOLE HUB
3	RT-2173	INNER BEARING
4	RT-2169	INNER RACE
5	RT-2174	HUB WITH RACES, 8 HOLE HUB
6	GZ-0601	GREASE ZERK
7	HD-1171	OUTER RACE

Item	Part Number	Description
8	HD-1363	OUTER BEARING
9	RT-2176	SPINDLE FLAT WASHER, 13/16
10	RT-2177	SPINDLE HEX CASTLE NUT, 3/4 - 16
11	CP-5312	COTTER PIN (0.150 X 1-1/4)
12	WB-5610	WHEEL BOLTS, 9/16 - 18 X 1 11/16
13	RT-2178	DUST CAP
—	RT-2171	8-HOLE HUB ASSEMBLY (Includes items 2,3,5,8,13)

Hub Components for RT-3181/RD-4580

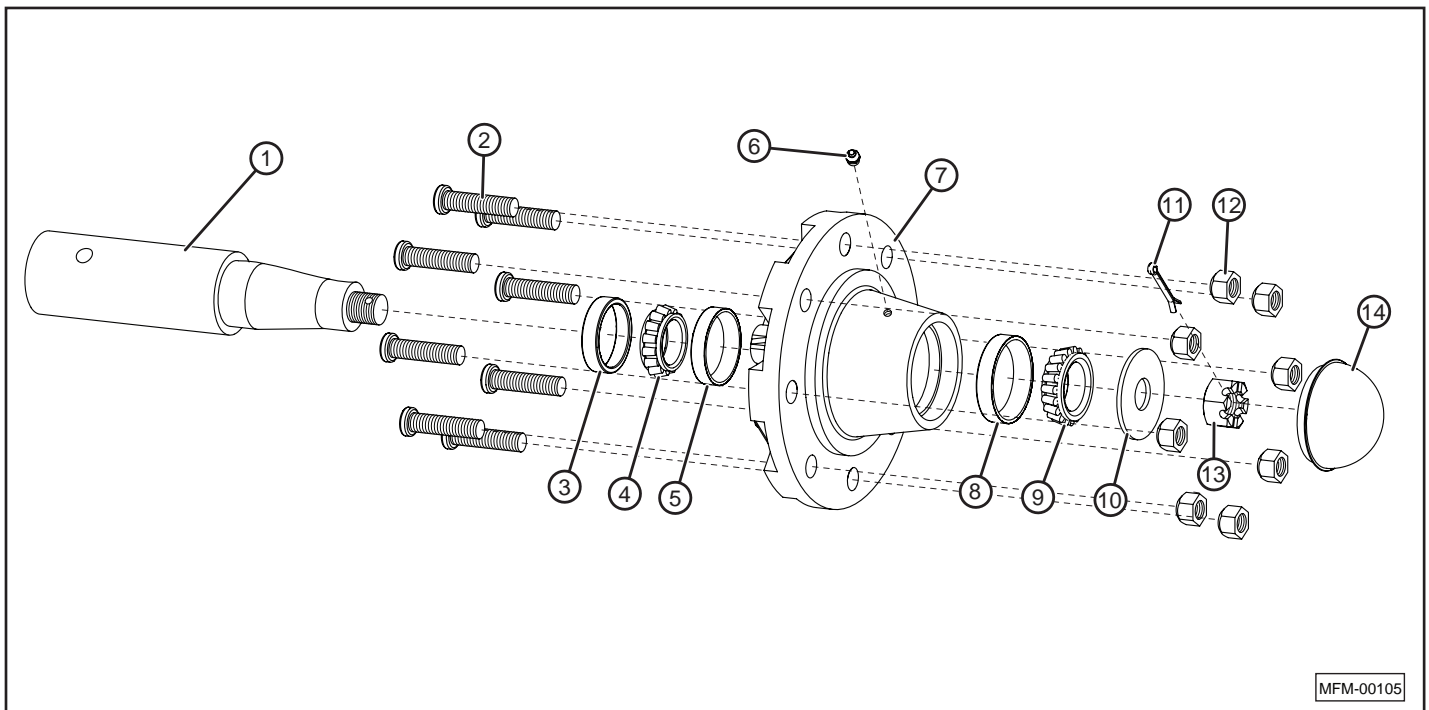

Item	Part Number	Description
8-BOLT HUB, 6000 LB		
1	RT-3180	SPINDLE, 2-3/4 X 12-1/2
2	RT-3193	WHEEL STUD 5/8-18 X 2-1/2
3	RT-3182	GREASE SEAL, 8 BOLT HD HUB
4	RT-3183	INNER BEARING
5	RT-3191	INNER RACE
6	GZ-0601	GREASE ZERK
7	RT-3184	HUB WITH RACES, 8 HOLE HUB
8	RT-3192	OUTER RACE
9	RT-3186	OUTER BEARING
10	RT-3190	SPINDLE FLAT WASHER, 1 5/16
11	CP-7320	COTTER PIN (0.207 X 2)
12	WN-0063	WHEEL NUTS 5/8
13	RT-3187	SPINDLE HEX CASTLE NUT, 1-14
14	RT-3188	DUST CAP
—	RT-3181	8-BOLT HUB ASSEMBLY, 6000 LB (Includes items 3,4,7,9,14)

Item	Part Number	Description
8-BOLT HUB, 7500 LB		
1	RD-4416	SPINDLE, 3 X 12-1/2
2	RT-3193	WHEEL STUD 5/8-18 X 2-1/2
3	RD-4582	GREASE SEAL, 8 BOLT 7500 LB HUB
4	RD-4583	INNER BEARING
5	RD-4584	INNER RACE
6	GZ-0601	GREASE ZERK
7	RD-4581	HUB WITH RACES, 8 BOLT 7500 LB HUB
8	RT-3192	OUTER RACE
9	RT-3186	OUTER BEARING
10	RT-3190	SPINDLE FLAT WASHER, 1 5/16
11	CP-7320	COTTER PIN (0.207 X 2)
12	WN-0063	WHEEL NUTS 5/8
13	RT-3187	SPINDLE HEX CASTLE NUT, 1-14
14	RT-3188	DUST CAP
—	RD-4580	8-BOLT HUB ASSEMBLY, 7500 LB (Includes items 3,4,7,9,14)

Layout Diagram for CB-4212

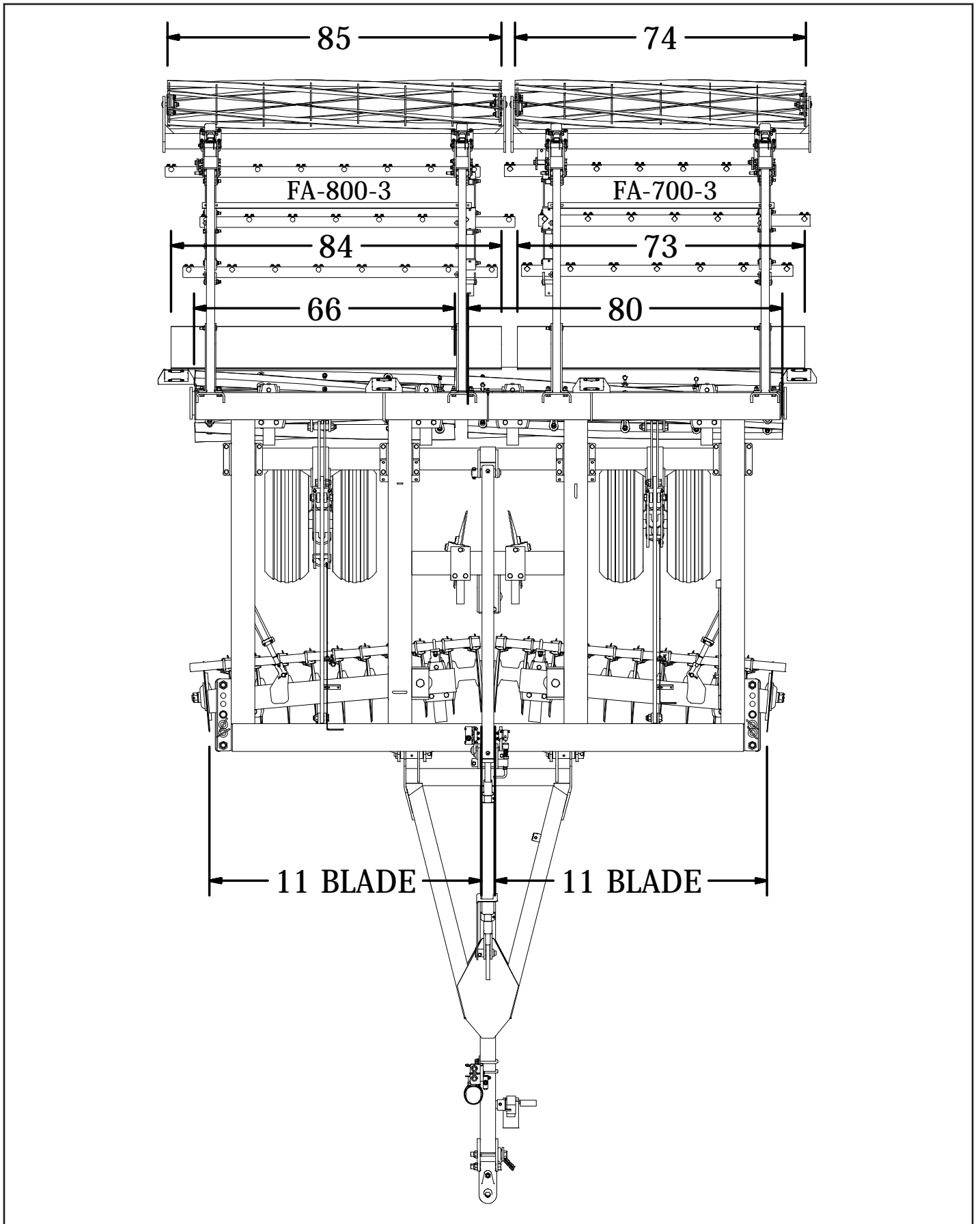

Layout Diagram for CB-4212-STRB

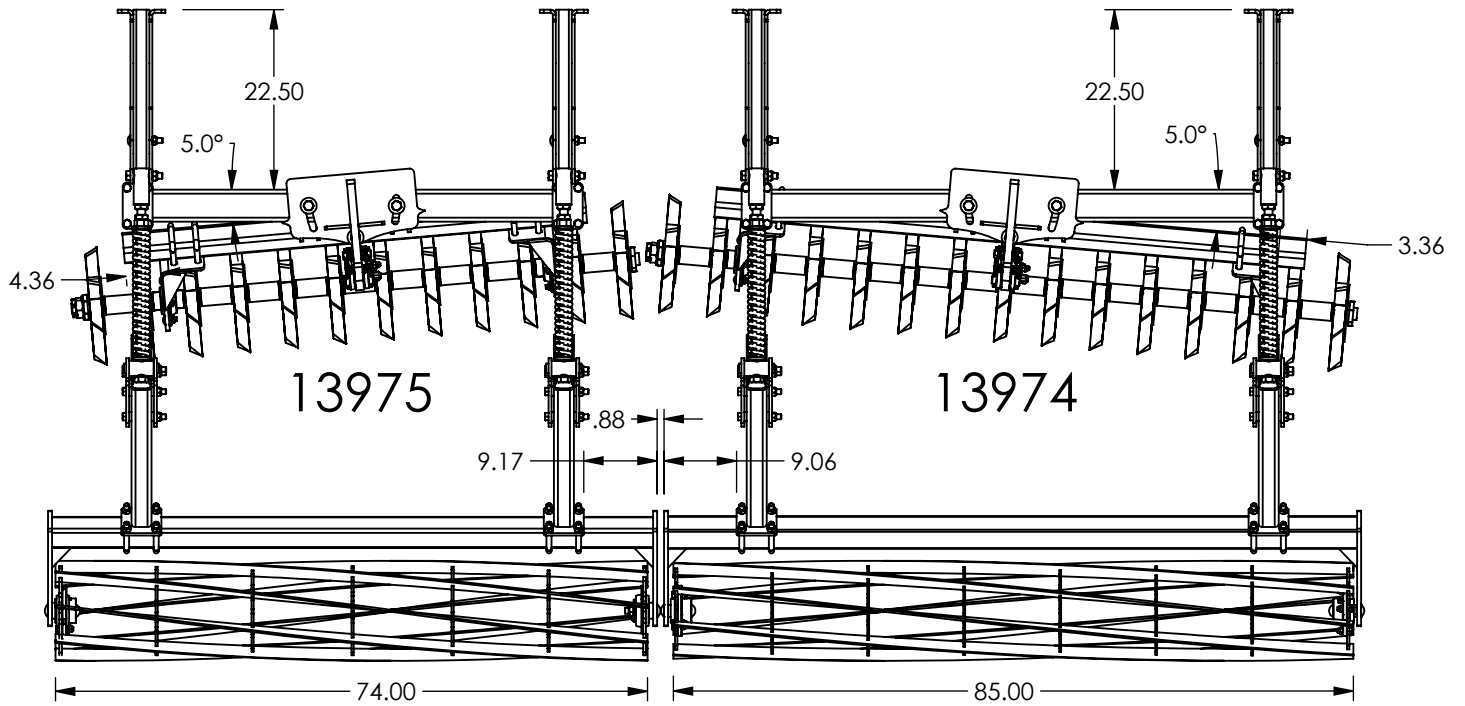

MFM-00432

Layout Diagram for CB-4214

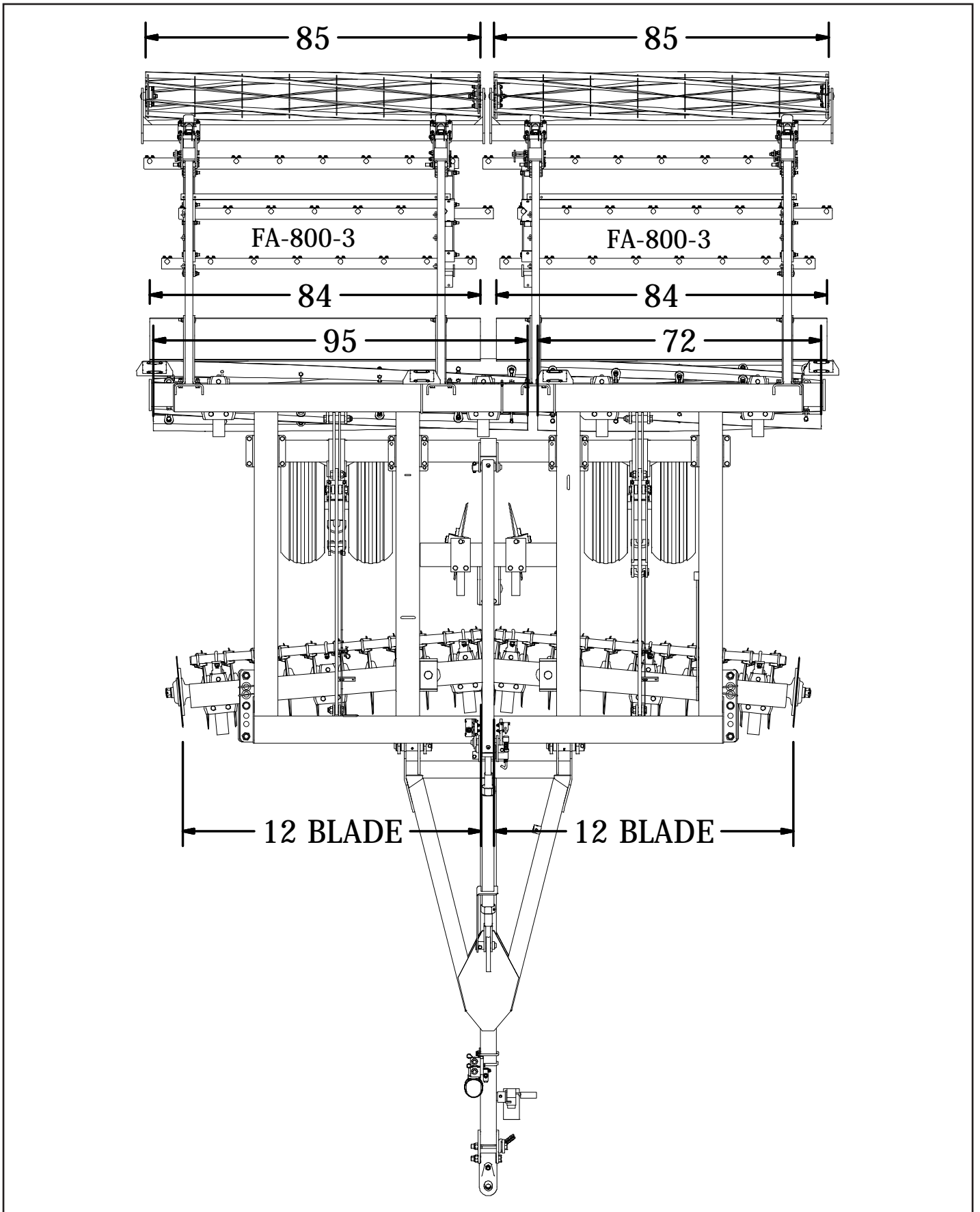

Layout Diagram for CB-4214-STRB

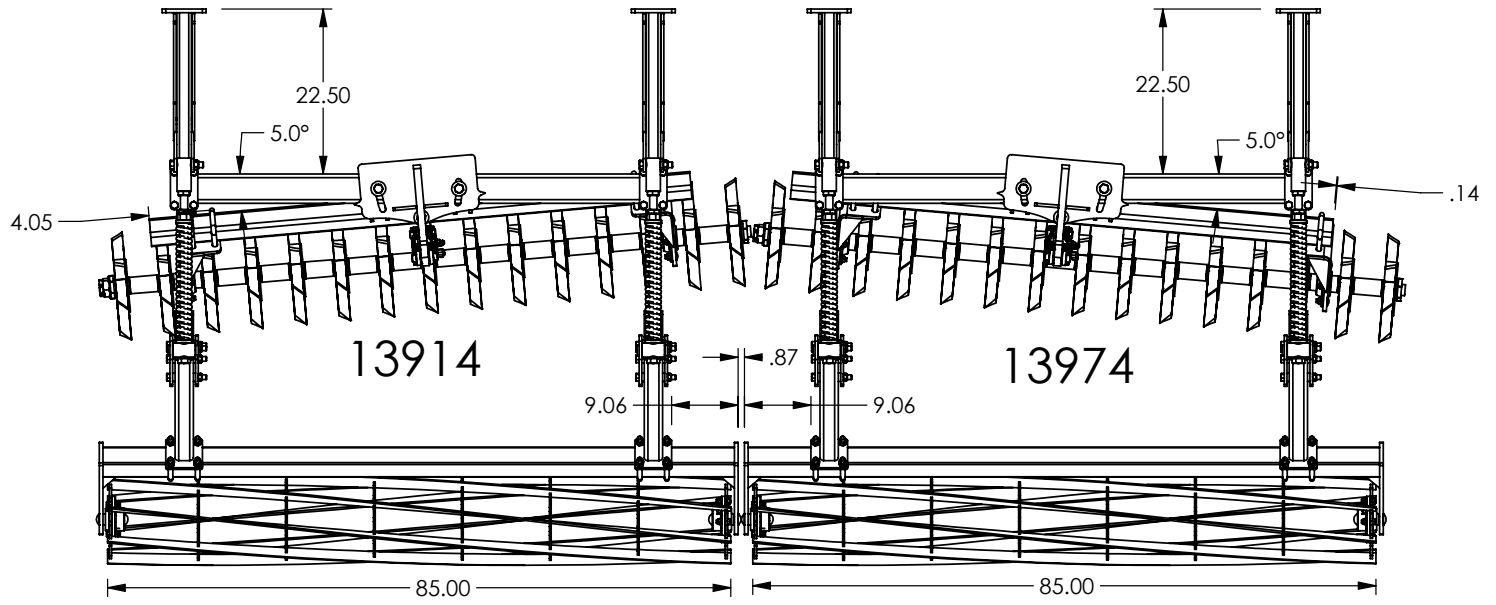

MFM-00433

Layout Diagram for CB-4220

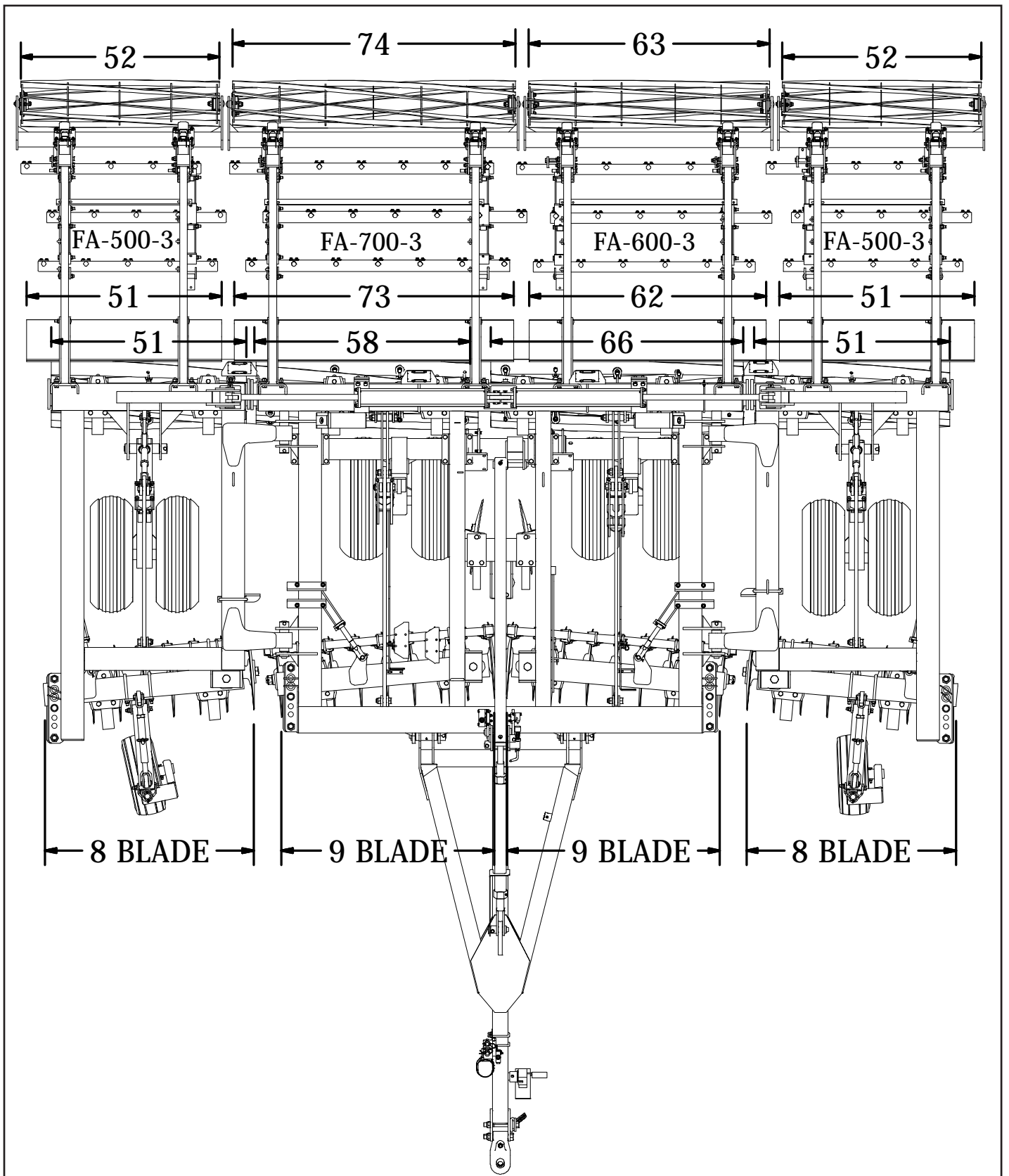

Layout Diagram for CB-4220-STRB

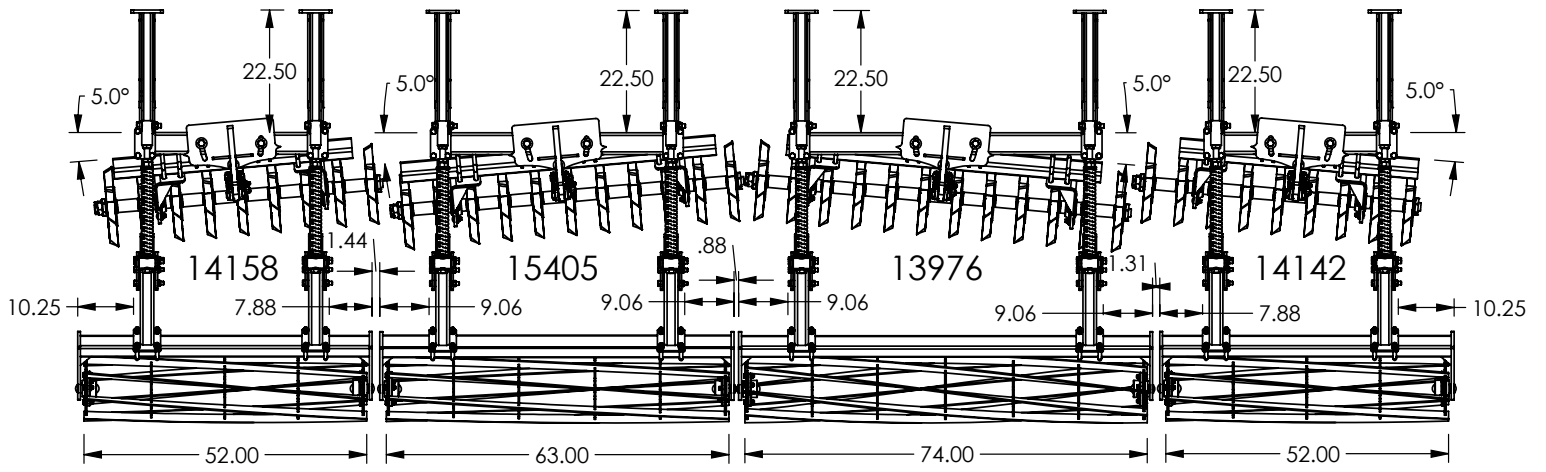

MFM-00434

Layout Diagram for CB-4225

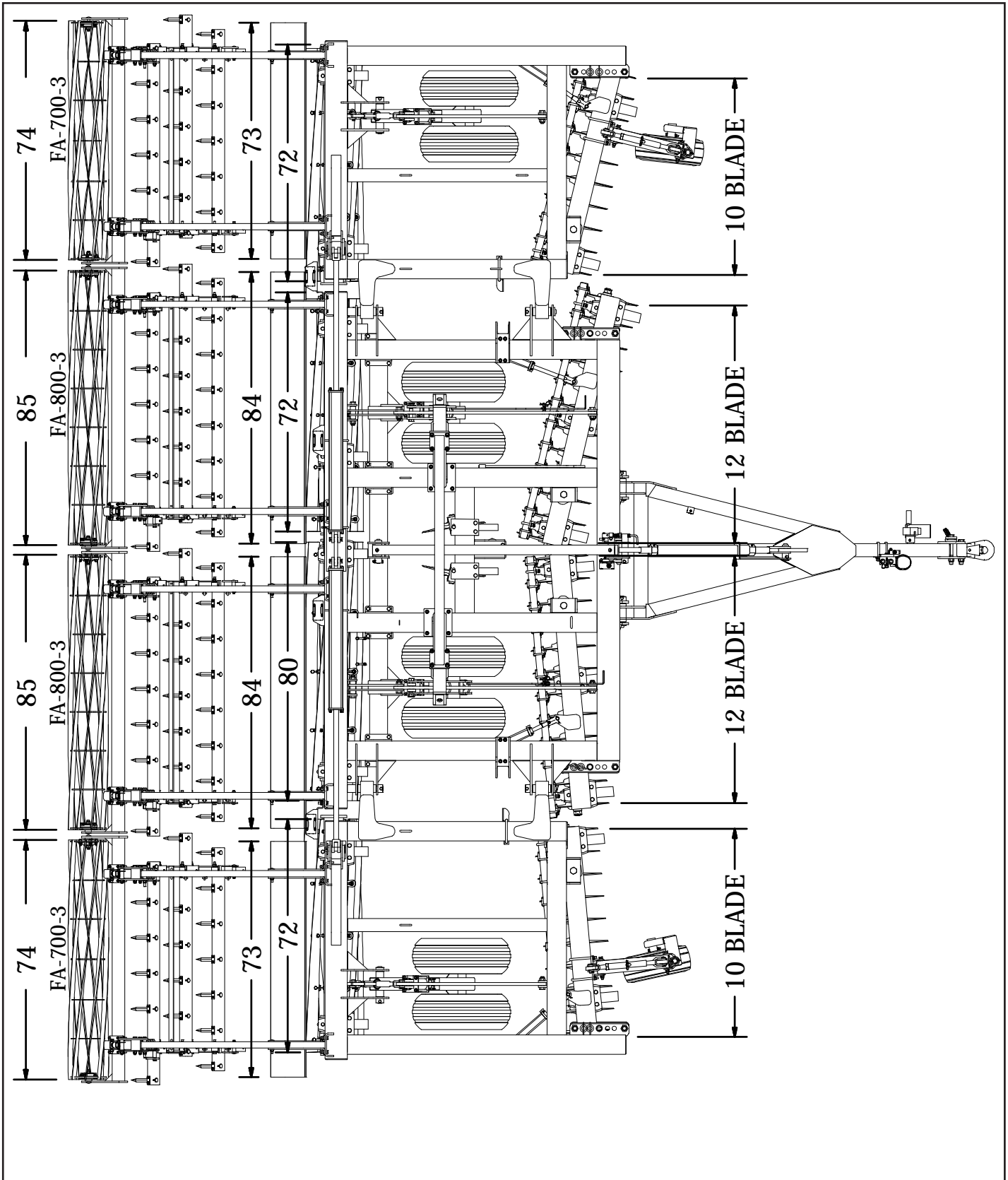

Layout Diagram for CB-4225-STRB

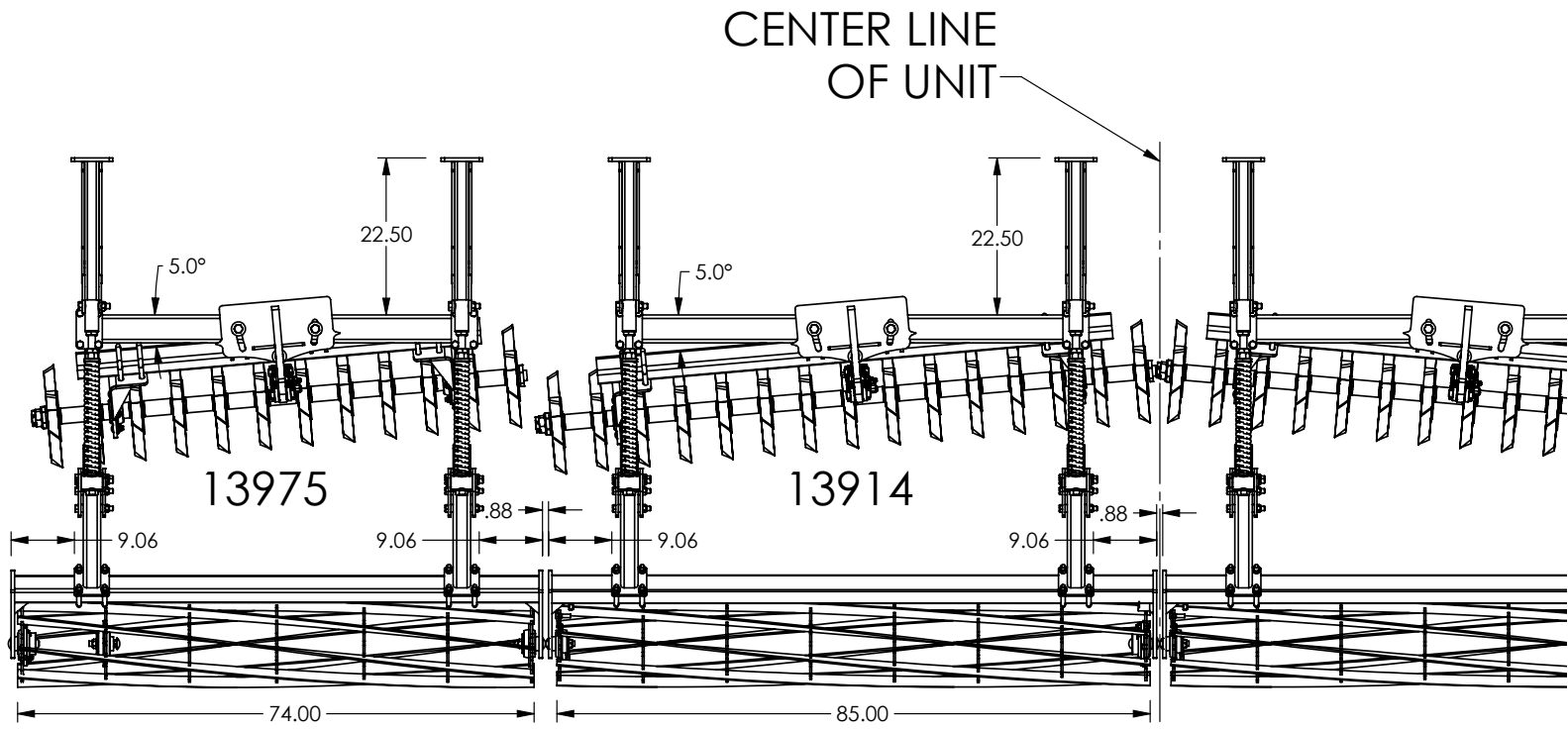

LEFT SIDE

MFM-00435

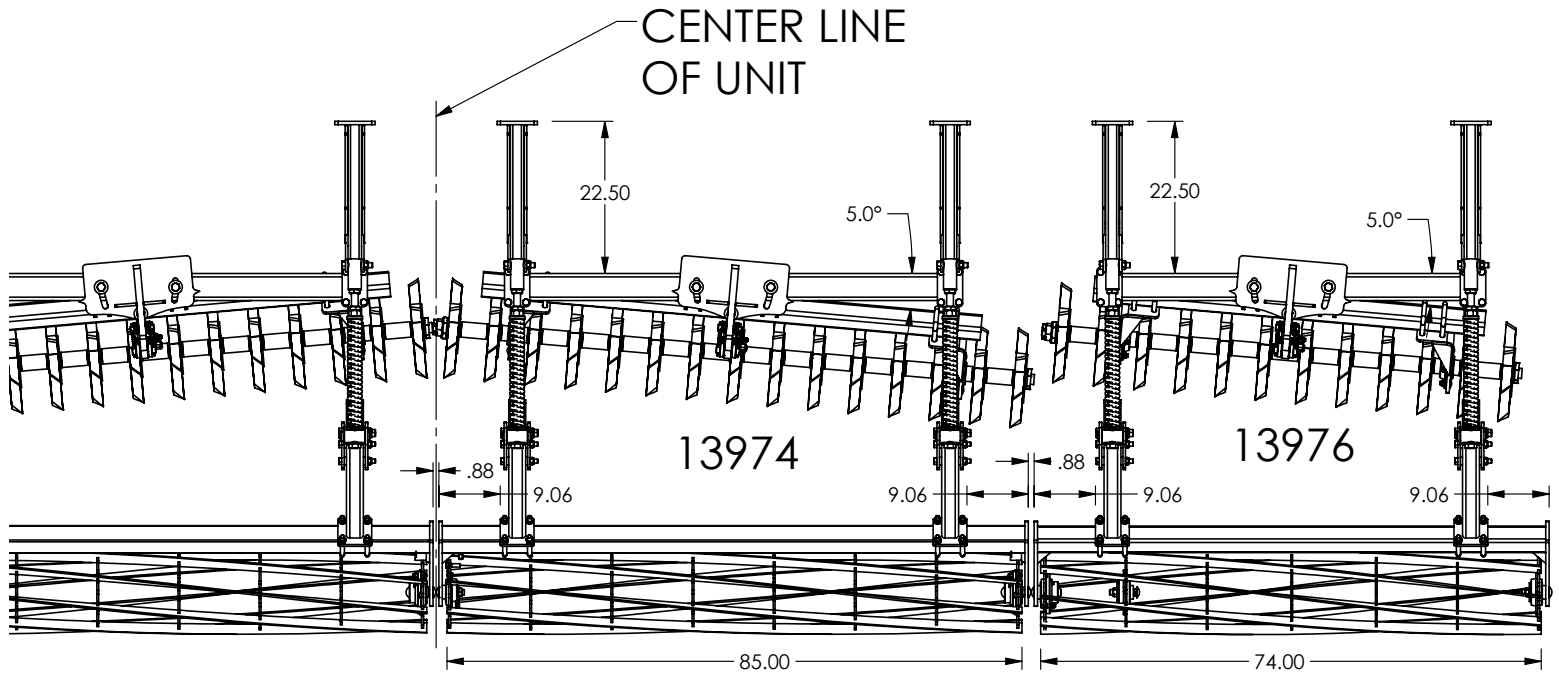

RIGHT SIDE

MFM-00436

Layout Diagram for CB-4230

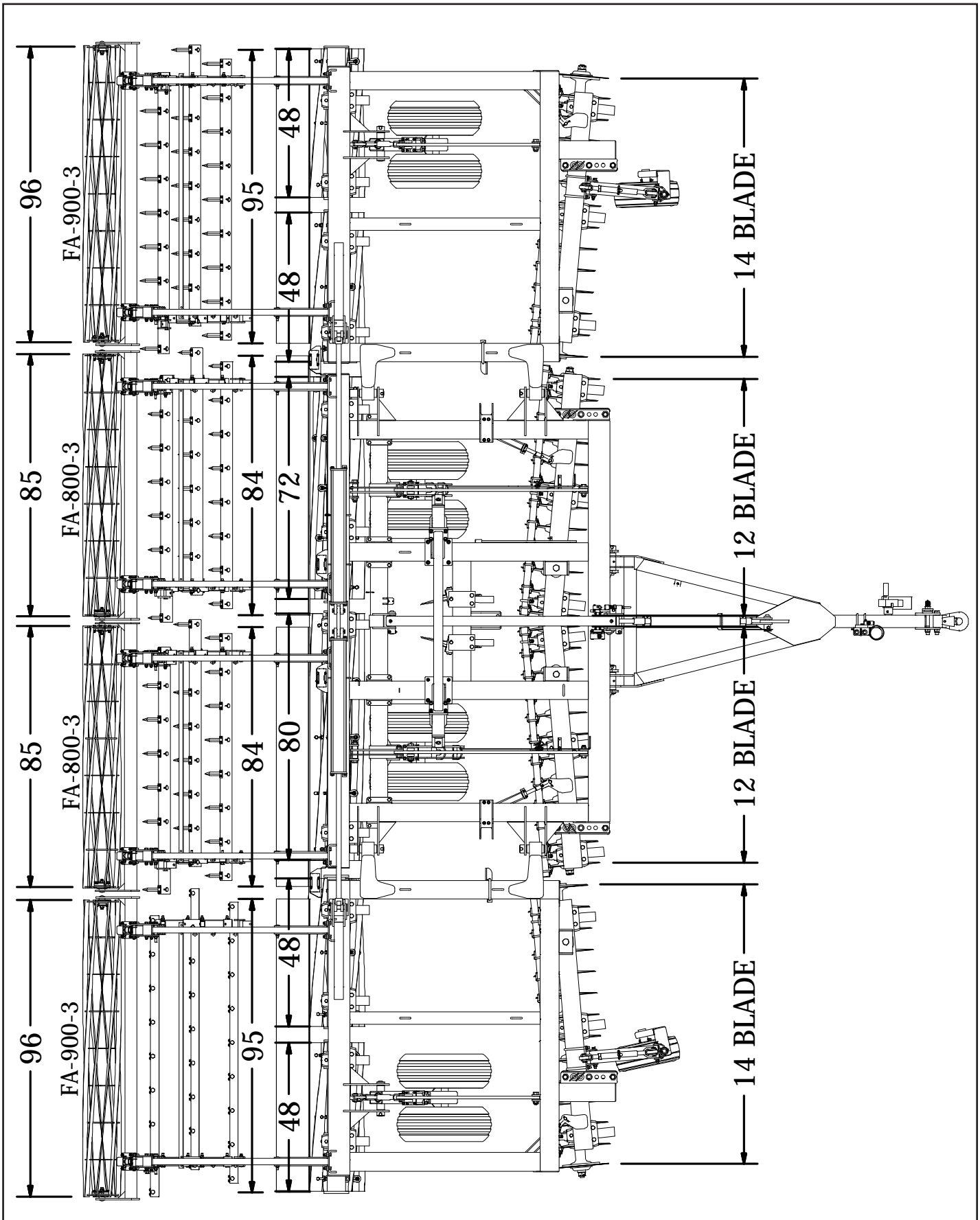

Layout Diagram for CB-4230-STRB

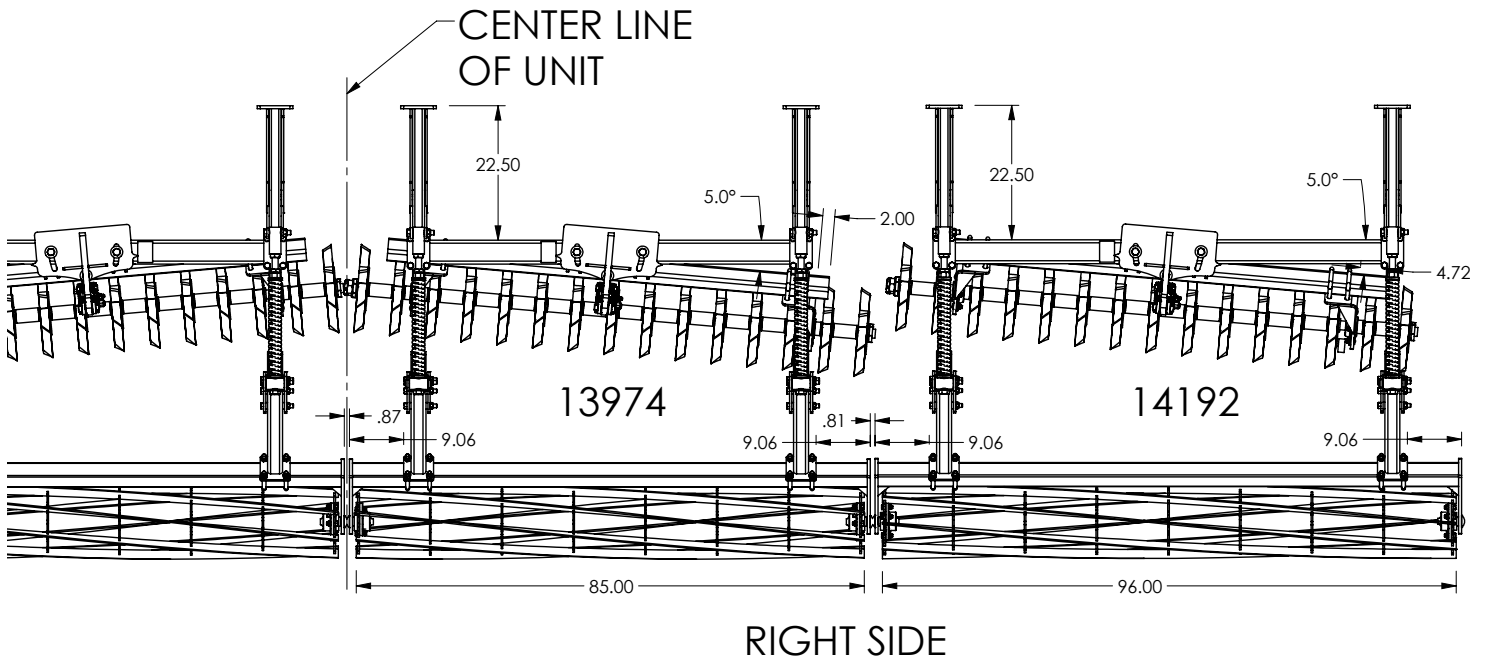
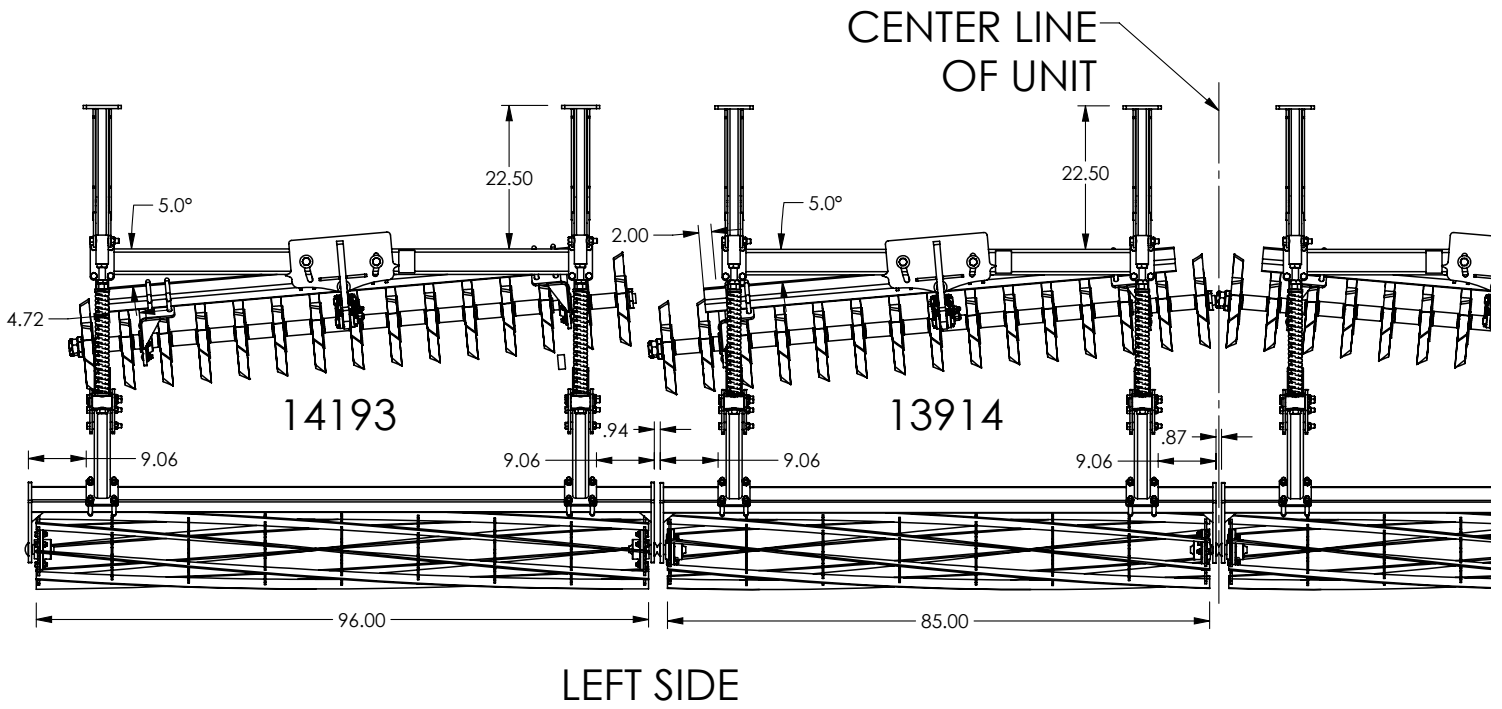

Layout Diagram for CB-4235

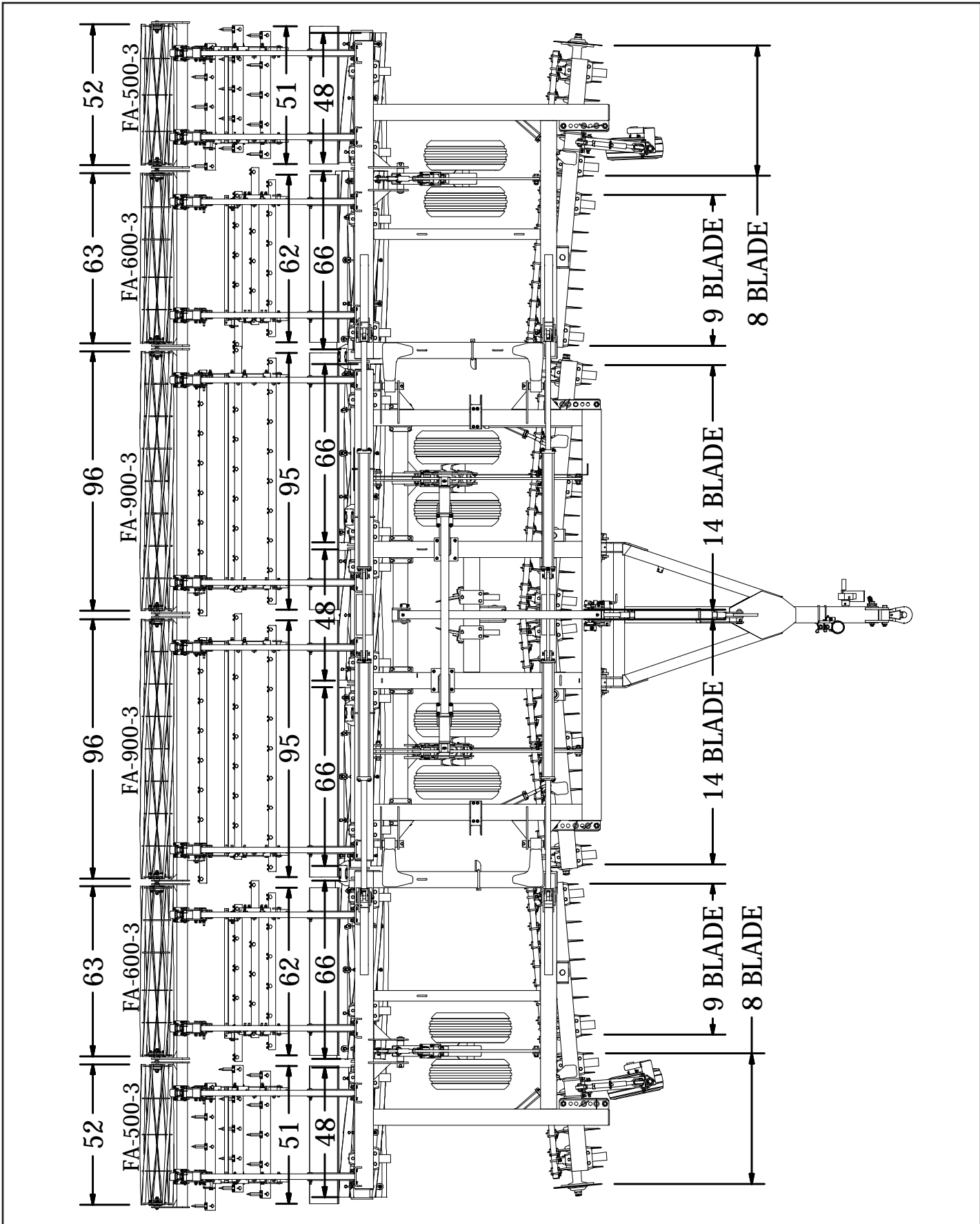

Layout Diagram for CB-4235-STRB

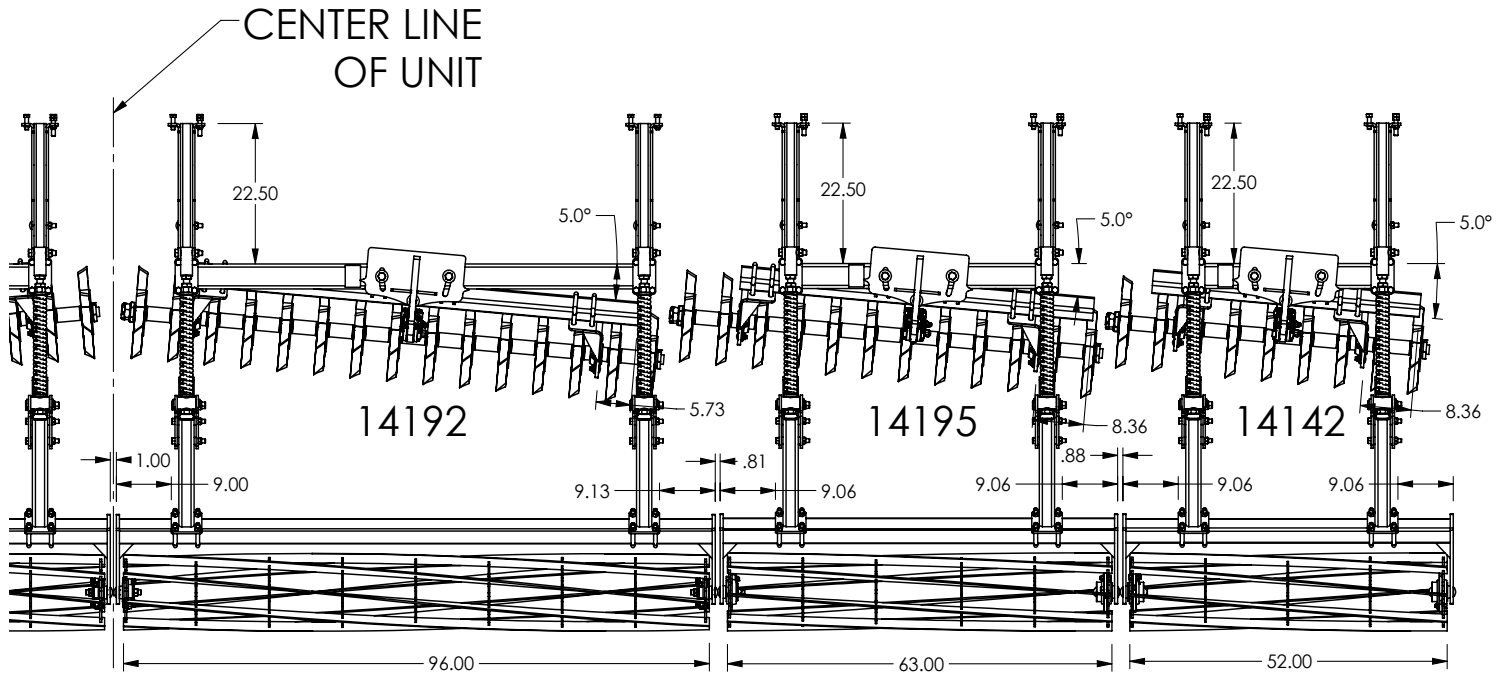

RIGHT SIDE

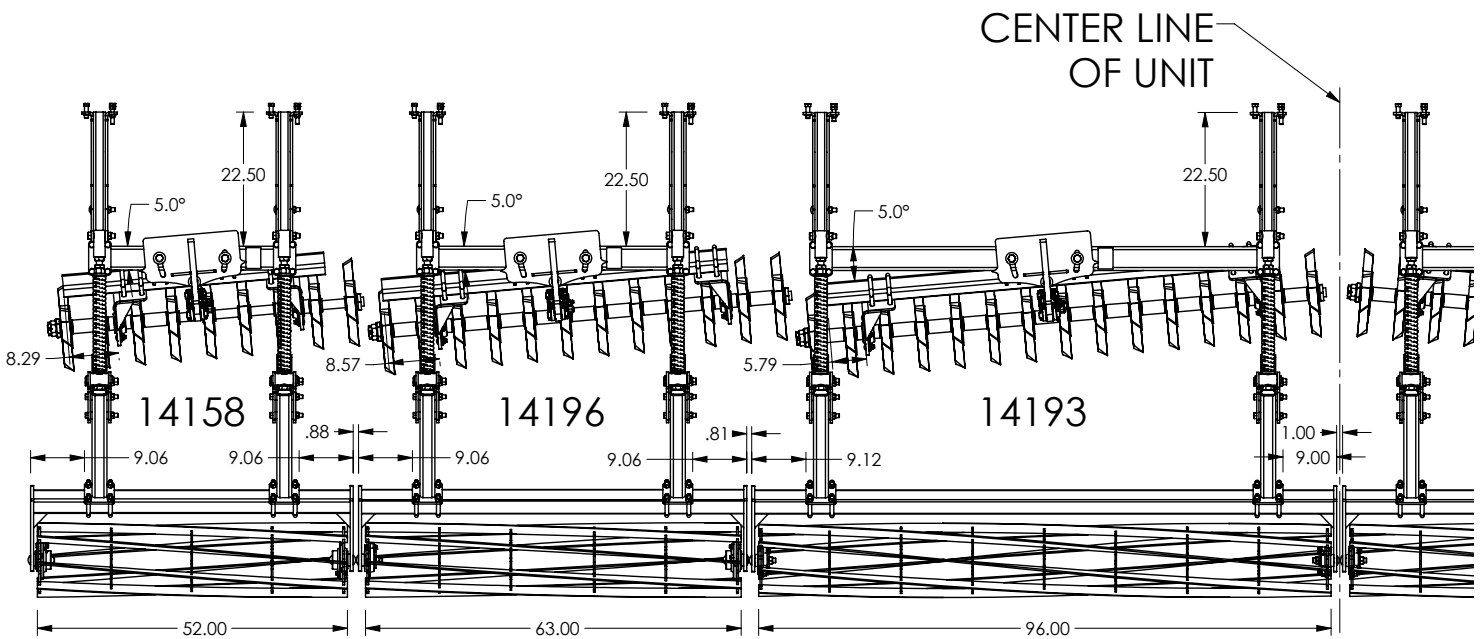

LEFT SIDE

Layout Diagram for CB-4245

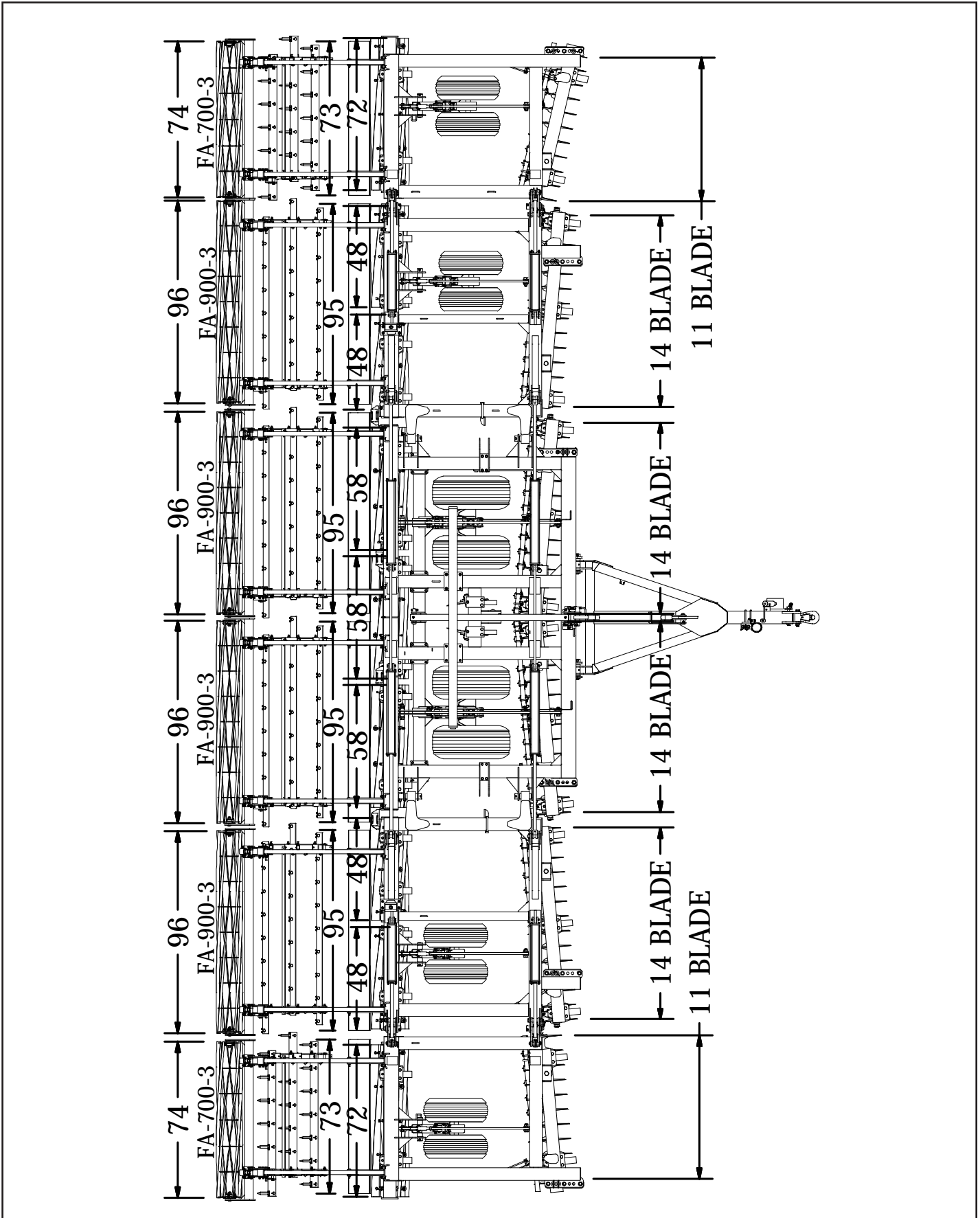

Layout Diagram for CB-4245-STRB

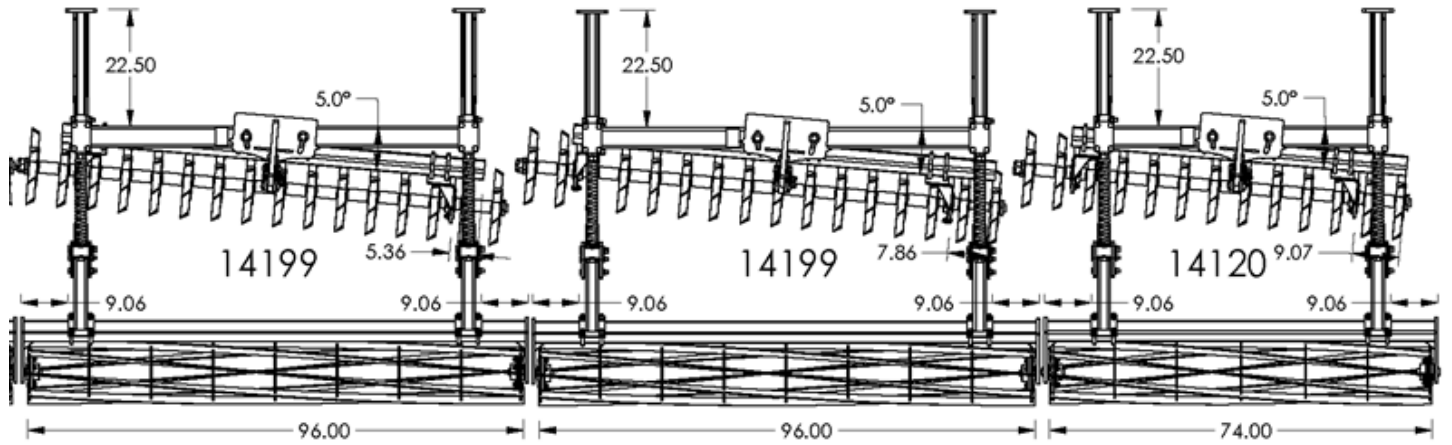
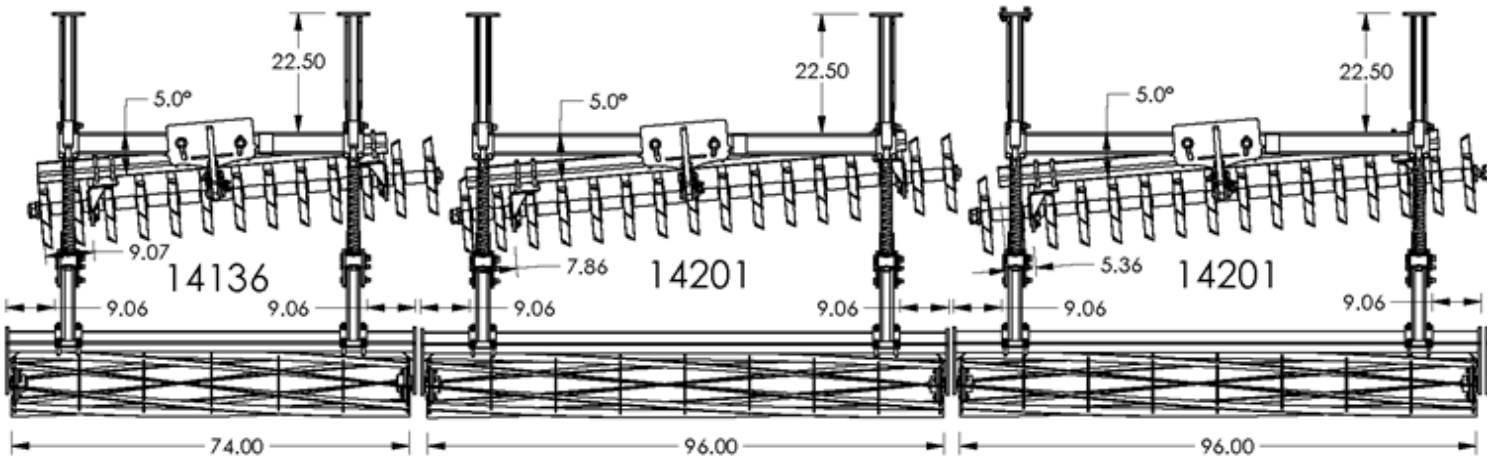

WARRANTY REGISTRATION FORM & INSPECTION REPORT

This form must be filled out by the dealer and buyer and the initialed and signed copy sent to: McFarlane Mfg. Co., Inc., 1259 South Water Street, P.O. Box 100, Sauk City, WI 53583.

WARRANTY REGISTRATION

This form must be filled out by the dealer and signed by both the dealer and customer at the time of delivery.

Customer Name _____ Dealer Name _____

Address _____ Address _____

City, State, Zip Code _____ City, State, Zip Code _____

Phone Number (____) _____

Model _____ Serial Number _____ Delivery Date _____

INSPECTION ITEMS

SAFETY

Buyer's
Initials

Buyer's
Initials

_____ Wheel bolts are tightened to the correct torque. Refer to the Tire and Lug Torque Specifications Chart in this manual.

_____ All decals are properly installed and readable. Refer to the Hazard and Information Signs section in this manual.

_____ Tires are properly inflated. Refer to the Tire and Lug Torque Specifications Chart in this manual.

_____ Read and understand all operating and safety instructions in this manual.

_____ All fasteners are tightened to the correct torque. Refer to the Bolt Torque Specifications Chart in this manual.

_____ All hydraulic hoses move freely without pinching or binding.

_____ All hydraulic hoses, cylinders, and/or component fittings are tight with no leakage.

_____ All grease fittings have been properly lubricated. Refer to the Lubrication section in this manual.

I have thoroughly instructed the buyer on the above-described equipment; the review included both the Assembly and Operation & Parts manuals, equipment care, adjustments, safe operation, and applicable warranty policy.

Date _____ Dealer's Signature _____

The above equipment and operator's manual have been received by me, and I have been thoroughly instructed as to care, adjustments, safe operation, and applicable warranty policy.

Date _____ Owner's Signature _____

Member of:



1330 Dallas St
PO box 100
Sauk City, WI 53583

Phone: (608) 643.3322
Toll Free: (888) 627.8569

mcfarlaneag.com

For more information email:
info@mcfarlanemfg.com

Copyright 2021 McFarlane Mfg.

Last revised: 07/12/2021

Cobra 4200 Series

108



Mcfarlaneag.com

888-627-8569