

41', 45' & 50' SUPERROLLER
41', 45' & 50' SUPERROLLER

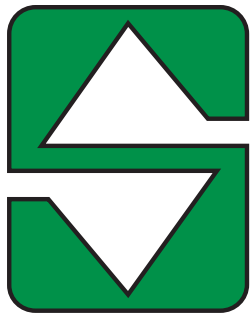

SUMMERS®

Operator's Manual

41', 45' & 50' HYDRAULIC WING FOLD SUPERROLLER

IMPORTANT

THE OPERATOR IS RESPONSIBLE FOR ADJUSTING THE MACHINE SINCE MACHINE DOES NOT COME "FIELD READY" FROM FACTORY.



CAUTION

READ & UNDERSTAND OPERATOR'S MANUAL BEFORE USING MACHINE.

See www.summersmfg.com for latest version of all Summers Operator's Manuals.

SUMMERS MANUFACTURING CO., INC.
WEB SITE: www.summersmfg.com

DEVILS LAKE, NORTH DAKOTA 58301..... (701) 662-5391

Warranty

Summers warrants only products of its manufacture against operational failure caused by defective materials or workmanship which occur during normal use within 36 months from the date of purchase by the end user from Summers' dealer.

Summers' obligation is to replace free of charge any part of any product that Summers inspection shows to be defective excluding transportation charges to Devils Lake, ND and return and also excluding all transportation costs from Summers' dealer to the dealer's customer and all other costs such as removal and installation expense.

Summers shall not be liable for loss of time, manufacturing costs, labor, material, loss of profits, consequential damages, direct or indirect, because of defective products whether due to rights arising under the contract of sale or independently thereof, and whether or not such claim is based on contract, tort or warranty.

Written permission for any warranty claim return must be first obtained from authorized Summers' personnel. All returns must be accompanied with a complete written explanation of claimed defects and the circumstances of operational failure.

Written warranty for all component parts used in the manufacture of Summers products is available upon request. Warranty of such component parts will be determined by said component manufacturer upon their inspection of the claimed defective part.

This express warranty is the sole warranty of Summers. There are no warranties, which extend beyond the warranty herein expressly set forth. The sales for products of Summers under any other warranty or guarantee express or implied is not authorized. This warranty voids all previous issues.

SUMMERS MANUFACTURING CO. INC.
DEVILS LAKE, NORTH DAKOTA 58301

01/16

INTRODUCTION

This manual provides the following information about your Summers Land Roller.

SECTION CONTENTS

- Section 1 – SAFETY explains important safety precautions and familiarizes the Operator with the decals and their locations.
- Section 2 – ASSEMBLY includes step by step assembly instructions for your Summers Land Roller.
- Section 3 – LAND ROLLER OPERATION provides necessary information for the operation and adjustment of the machine.
- Section 4 – MAINTENANCE covers recommended mechanical maintenance. TROUBLESHOOTING provides a quick reference to solving problems. SPECIFICATIONS lists important dimensions, capacities and other technical information.
- Section 5 – PARTS

OTHER ITEMS OF IMPORTANCE

- A. Summers Mfg. Co., Inc. strongly recommends that each Land Roller Operator **READ and UNDERSTAND** the Operator's Manual before using the machine. In addition, this Operator's Manual should be **REVIEWED at least ANNUALLY** thereafter.
- B. It is the policy of this company to improve its products whenever possible and practical to do so. We reserve the right to make changes or improvements in the design or construction of parts at any time without incurring obligations to install such changes on products previously delivered.
- C. Reference to "right" and "left" in this manual is determined when machine is viewed from the rear.
- D. Parts are referenced in each drawing with the Summers Manufacturing Part Number. Use this Part Number when ordering replacement parts from your Summers dealer. See back section of manual for description of each Part Number.
- E. **WARNING – DO NOT ATTEMPT** to raise machine into transport position if mud has built up on rollers or if machine weight has been increased by any other means. Mechanical failure may occur.
- F. Ability to safely operate the Summers Superroller is determined by both tractor horsepower and weight. The minimum tractor weight for operating this implement is 16,000 lb. Minimum tractor engine horsepower is 160. Dual tires or single tires set at maximum width are required for safe operation of Land Roller.
- G. Never tow this implement with less than a 16,000 lb. vehicle. Tongue weight in transport position is approximately 2000 lb. Tongue lift force when folding in and out of transport position is 2000 lb.
- H. **NEVER ALLOW** anyone to walk or work under Land Roller wings or center section.

OWNER REGISTER

Name _____	Size _____
Address _____	Serial Number _____ <small>(located by the hitch piece)</small>
City _____	
State/Prov. _____	Date Purchased _____
Mail Code _____	Dealer _____

TABLE OF CONTENTS

SECTION 1 – SAFETY

Safety-Alert Symbol.....	1-1
General Safety Practices.....	1-1
Safety During Transport.....	1-2
Safety Decals	1-2
Decals and Their Locations	1-2-1-6

SECTION 2 – ASSEMBLY

General Assembly Safety Instructions.....	2-1
Safety Alert Symbol	2-1
General Safety Practices.....	2-2
Set-Up of Frame	2-3 – 2-9
Hydraulic Set-Up	2-6, 2-7
Installation of Wing Rollers	2-10
Decals.....	2-12

SECTION 3 – LAND ROLLER OPERATION

Land Roller Operation Safety	3-1
Steps Prior to Operation	3-1
Initial Hookup.....	3-2
Steps Required to Unfold from Transport to Field Position	3-3, 3-4
Field Operation.....	3-5
Steps Required to Fold from Field to Transport Position.....	3-5
Procedure to Adjust Hydraulic Cylinder Attach Eye Bolts.....	3-6, 3-7
Transporting	3-8
Unhooking Land Roller From Tractor	3-9, 3-10

SECTION 4 – MAINTENANCE

Maintenance Safety.....	4-1
Maintenance for after the First Two Hours of Operation	4-1
Daily and Periodic Maintenance	4-1
Storage, Troubleshooting, Specifications	4-2
Bolt Torque Specifications	4-3

SECTION 5 – PARTS

Hitch Center.....	5-2
Transport Rest.....	5-3
Hydraulics.....	5-4
Wing	5-5
Roller Installation	5-6
Safety Lights.....	5-7
Hub and Axle Components.....	5-8
Acre Meter Option	5-9
Part Numbers	5-10 – 5-11

SECTION 1 - SAFETY

SAFETY-ALERT SYMBOL



This symbol is used to denote possible danger and care should be taken to prevent bodily injury. This symbol means:

ATTENTION! BECOME ALERT! **YOUR SAFETY IS INVOLVED!**

Definition of each **Signal Word** used in conjunction with the **Safety-Alert** symbol.



indicates an imminently hazardous situation which, if not avoided, will result in death or serious injury. This signal word is limited to the most extreme situations.



indicates a potentially hazardous situation which, if not avoided, could result in death or serious injury.



indicates a potentially hazardous situation which, if not avoided, may result in minor or moderate injury. It may also be used to alert against unsafe practices.

GENERAL SAFETY PRACTICES

1. READ AND UNDERSTAND Operator's Manual before using machine. Review at least annually thereafter.
2. VERIFY all safety devices and shields are in place before using machine.
3. KEEP hands, feet, hair and clothing away from moving parts.
4. STOP engine, place all controls in neutral, set parking brake, remove ignition key and wait for all moving parts to stop before servicing, adjusting, maintaining or unplugging.
5. BE CAREFUL when working around high pressure hydraulic system.
6. ALWAYS make sure Land Roller is lowered into field position (cylinders extended), it is blocked to prevent movement and that pressure is relieved from hydraulic circuits before servicing.
7. DO NOT ALLOW RIDERS.
8. USE EXTREME CARE when making adjustments.
9. KEEP CHILDREN AWAY from machinery at all times.
10. NEVER ALLOW anyone to walk or work under Land Roller wings or center section.
11. WARNING – DO NOT ATTEMPT to raise machine into transport position if mud has built up on rollers or if machine weight has been increased by any other means. Mechanical failure may occur.

SECTION 1 - SAFETY

SAFETY DURING TRANSPORT

1. Ability to safely operate the Summers Superroller is determined by both tractor horsepower and weight. The minimum tractor weight for operating this implement is 16,000 lbs. Minimum tractor engine horsepower is 160. Dual tires or single tires set at maximum width are required for safe operation of Land Roller.
2. ONLY TOW at a safe speed – 20 MPH MAXIMUM. Use caution when making corners and meeting traffic.
3. USE Safety Lights and Safety Chain between tractor drawbar and implement hitch when transporting on public roads.
4. ALWAYS install transport safety chains and close wing lock hydraulic valve before transporting on public roads.
5. FOLLOW ALL local laws governing transporting of farm machinery.
6. Use additional caution and reduce speed when towing under adverse conditions, when turning and when on unlevel surfaces. Frequently check for traffic from rear, especially during turns.
7. Stay clear of overhead lines and other overhead obstructions.

SAFETY DECALS

1. KEEP SAFETY DECALS CLEAN.
2. REPLACE missing or unreadable decals. New decals are available from your Summers dealer by ordering correct part number (PN) located on the decal.

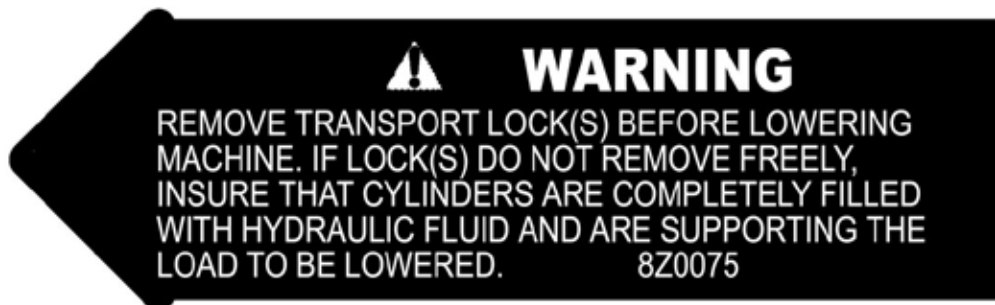

DECALS AND THEIR LOCATIONS

1. PN 8Z0075 – DECAL FOR REMOVING TRANSPORT LOCKS



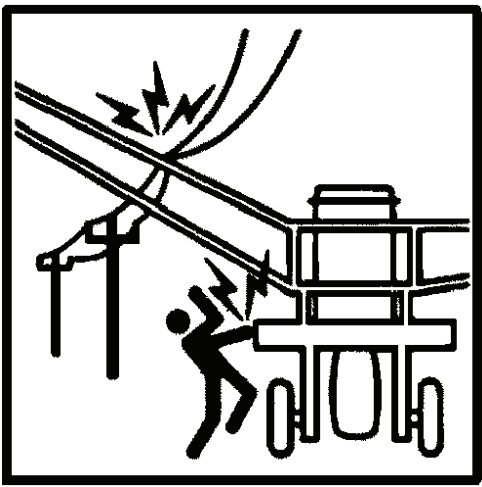

SECTION 1 - SAFETY

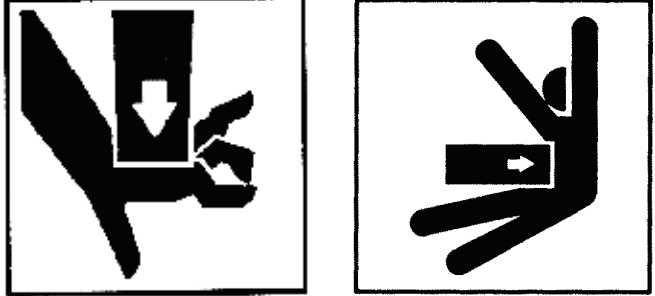

2. PN 8Z0086 – ELECTRICUTION DANGER

	<p> DANGER</p> <p>AVOID CONTACT WITH ELECTRICAL LINES. SERIOUS INJURY OR DEATH CAN RESULT.</p> <p>8Z0086</p>
---	--

3. PN 8Z0087 – DECAL FOR PINCH POINT HAZARD



	<p> DANGER</p> <p>FRAME PINCH POINT HAZARD <i>KEEP AWAY</i></p> <p>To prevent serious injury or death from crushing:</p> <ul style="list-style-type: none">• Stay away from frame hinge area when folding wings.• Keep others away.• Do not fold wings when bystanders are present. <p>8Z0087</p>
--	---

4. PN 8Z0104 – DECAL FOR LANDROLLER

<p> WARNING</p>	
	<p>LANDROLLER MUST BE SECURED TO AT LEAST A 16,000 LB AND 160 ENGINE HP TRACTOR DRAWBAR WITH A LOCKED HITCH PIN WHEN TRANSPORTING AND DURING FIELD OPERATION.</p> <p>DO NOT ATTEMPT TO RAISE LANDROLLER INTO TRANSPORT POSITION IF MUD HAS BUILT UP ON ROLLERS OR IF MACHINE WEIGHT HAS BEEN INCREASED BY ANY OTHER MEANS. MECHANICAL OR HYDRAULIC FAILURE MAY OCCUR.</p> <p>BLOCK MACHINE FROM ROLLING, LOWER HITCH JACK AND BE CERTAIN THAT NO UPWARD OR SIDE PRESSURE IS EXERTED ON TRACTOR DRAWBAR BEFORE DISCONNECTING.</p> <p>8Z0104</p>

SECTION 1 - SAFETY

5. PN 8Z0106 – DECAL FOR LANDROLLER DANGER

 DANGER	
	<p>TO AVOID INJURY OR DEATH STAND CLEAR OF MACHINE WHEN WINGS AND CENTER ARE BEING RAISED OR LOWERED. MECHANICAL OR HYDRAULIC FAILURE MAY OCCUR WHICH WILL ALLOW ROLLERS TO FALL RAPIDLY.</p>
	<p><u>NEVER ALLOW ANYONE TO WALK OR WORK UNDER LANDROLLER WINGS OR CENTER SECTION.</u></p> <p>WHEN MACHINE IS IN TRANSPORT POSITION, WALK AND WORK IN GREEN AREA <u>ONLY.</u></p> <p>INSTALL WING TRANSPORT SAFETY CHAINS AND CLOSE WING LOCK HYDRAULIC VALVE BEFORE TOWING.</p> <p>20 MPH MAXIMUM TRANSPORT SPEED.</p> <p style="text-align: right;">8Z0106</p>

6. PN8Z0204 – DECAL 5.5" SUMMERS

7. PN 8Z0276 – DECAL FOR GENERAL CAUTION

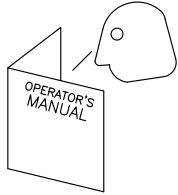
 CAUTION	
	<ol style="list-style-type: none">1. Read and understand Operator's Manual before using machine.2. For Sprayers:<ol style="list-style-type: none">a. Read and follow chemical manufacturers' WARNINGS, instructions and procedures before using.b. Use recommended personal protective equipment to reduce or eliminate chemical contact.c. Never run pump dry.3. Verify all safety devices and shields are in place before using machine.4. Keep hands, feet, hair and clothing away from moving parts.5. Stop engine, place all controls in neutral, set parking brake, remove ignition key and wait for all moving parts to stop before servicing, adjusting, maintaining or unplugging.6. Be careful when working around high pressure hydraulic system.7. Do not allow riders.8. Check all wheel bolts DAILY for tightness.9. Refer to Operator's Manual for periodic and annual maintenance.10. For Towed Implements; DO NOT EXCEED 20 MPH. <p style="text-align: right;">8Z0276</p>

SECTION 1 - SAFETY

8. PN 8Z0344 – DECAL FOR WING DANGER

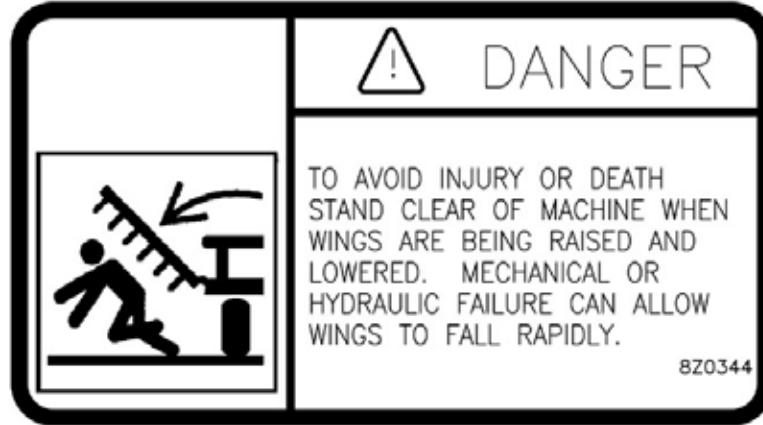

9. PN 8Z0346 – DECAL FOR ELECTRICUTION DANGER

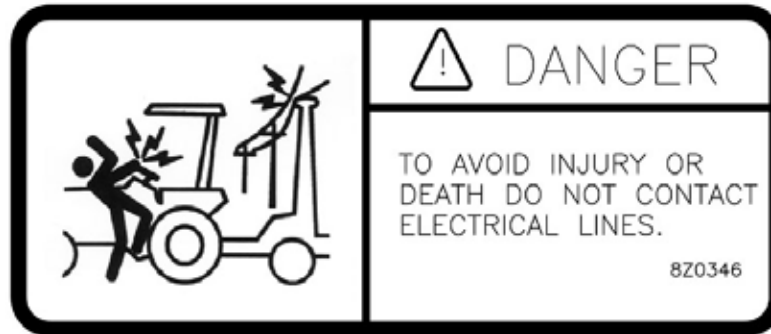

10. PN 8Z0800 – AMBER REFLECTOR

11. PN 8Z0805 – RED-ORANGE REFLECTOR

12. PN 8Z0810 – RED REFLECTOR

13. PN 8Z2195 - 41' & 45' LANDROLLER PRODUCT ID DECAL

RH8430

14. PN 8Z2197 – 50' LANDROLLER PRODUCT ID DECAL

RH8330

SAFETY LIGHT OPERATION

The Summers Safety Light Kit is equipped with a 7 pin connector. To protect 7 pin connector, store in dust cap (8K8067) when not attached to towing vehicle.

PN	QTY
8Z0075	2
8Z0086	1
8Z0087	3
8Z0104	1
8Z0106	1
8Z0204	5
8Z0276	1
8Z0344	4
8Z0346	1
8Z0800	6
8Z0805	4
8Z0810	4
8Z2195	2

1-6

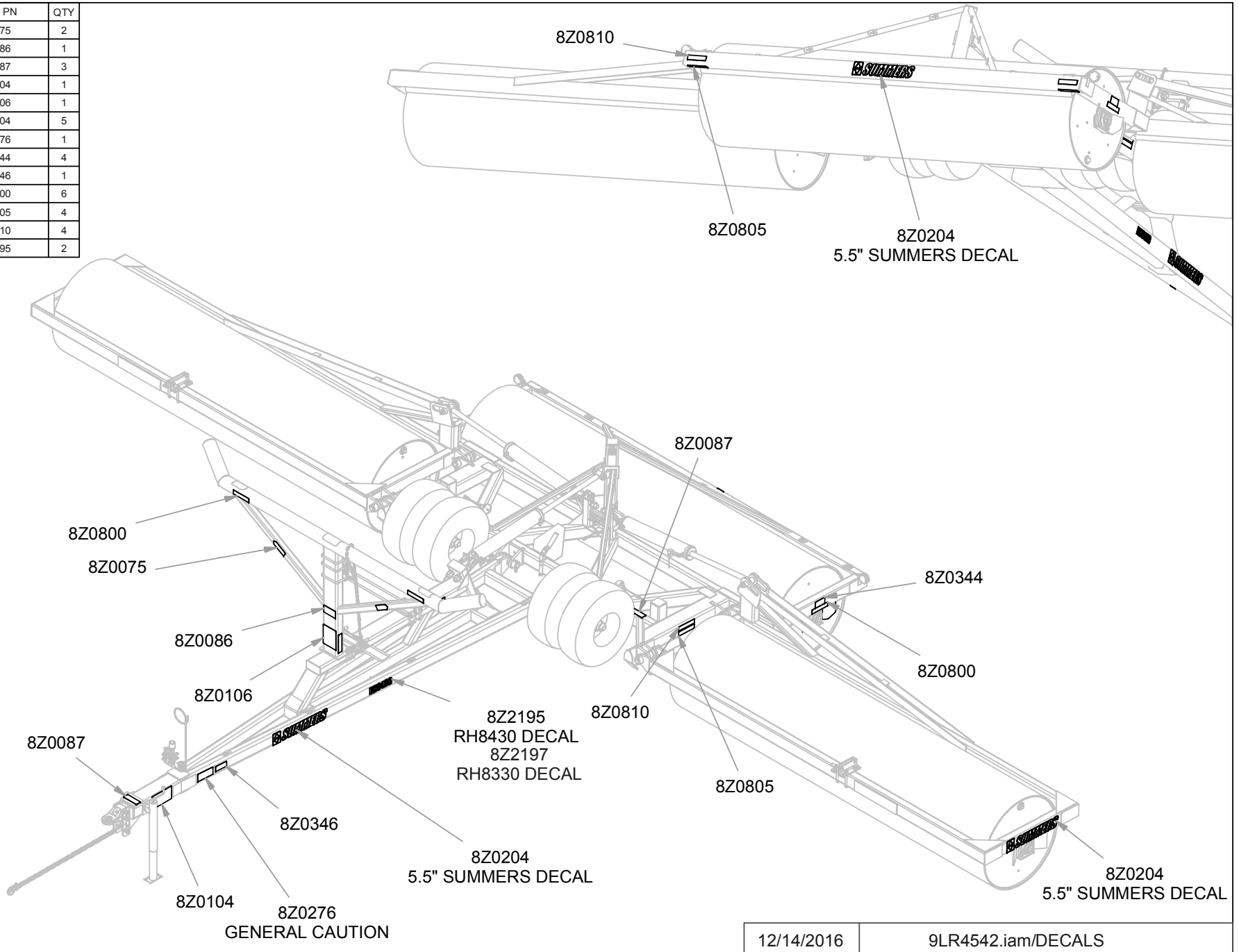

SECTION 1 - SAFETY

12/14/2016

9LR4542.iam/DECALS

GENERAL ASSEMBLY SAFETY PRACTICES

1. READ AND UNDERSTAND Operator's Manual before assembly of machine.
2. Machine should be assembled in a horizontal (field) position only.
3. If machine is to be assembled INDOORS, check that exit door is:

MACHINE WIDTH	MINIMUM DOOR WIDTH	MINIMUM DOOR HEIGHT
41'	17'2"	14'2"
45'	17'2"	15'2"
50'	16'10"	16'2"

4. Reference to "RIGHT" and "LEFT" is determined when machine IS VIEWED FROM THE REAR.
5. Reference to "FORWARD" means TOWARDS THE TRACTOR.
6. Reference to "REAR" means AWAY FROM THE TRACTOR.

SAFETY-ALERT SYMBOL



This symbol is an alert to the potential for personal injury. This symbol means **ATTENTION! BECOME ALERT!**
YOUR PERSONAL SAFETY IS INVOLVED!

GENERAL SAFETY PRACTICES



YOU ARE RESPONSIBLE for the safe assembly of the machine.



BLOCK UP ANY RAISED PART of the machine. Be sure machine is stable after blocking.



DO NOT ALLOW CHILDREN or other unauthorized persons within the assembly area.



ALWAYS INSPECT LIFTING CHAINS AND SLINGS for damage or wear.



WEAR PERSONAL PROTECTIVE EQUIPMENT which includes a hard hat, eye protection, work gloves and steel toed boots with slip resistant soles.



BE SURE LIFTING DEVICE IS RATED TO HANDLE THE WEIGHT.*



DO NOT MODIFY equipment or substitute parts in any way. Unauthorized modification may impair the function and/or safety of the machine.



STOP ENGINE, place all controls in neutral, set parking brake, remove ignition key and wait for all moving parts to stop before servicing or adjusting.



USE SUITABLE LIFTING DEVICE for components which could cause personal injury.



ALWAYS make sure Land Roller is lowered into field position (cylinders extended), it is blocked to prevent movement and that pressure is relieved from hydraulic circuits before servicing.



USE EXTREME CARE when assembling, servicing or adjusting.

***APPROXIMATE WEIGHTS OF COMPONENTS (36" / 42" ROLLER)**

PN	DESCRIPTION	WEIGHT (LB)	PN	DESCRIPTION	WEIGHT (LB)
8P4000	HITCH	1405	8P4205	ROLLER, 17-1/2' (36")	3913
	CENTER SECTION	2424	8P5000	UPRIGHT TRNSPRT REST	162
	WING	1300 / 1200	8P5020	BRACE TRNSPRT REST	98
8P4213	ROLLER, 13' (42")	3925	8P5040	CROSS TUBE TRNSPRT REST	395
	ROLLER, 15'	3409 / 4285	8P8645	BOX HARDWARE PARTS	1000

SECTION 2 - ASSEMBLY

CENTER ROLLER INSTALLATION

- CR1. Position Center Roller on a firm, level surface. CAUTION: Each Roller weighs up to 4285#, block to prevent unexpected movement.
- CR2. Clean Roller pivot shafts.
- CR3. Lower Center Frame over Roller. The Center weighs 2424#, use extreme caution when positioning over Roller.
- CR4. Install bearings with grease zerks toward rear of machine. Apply anti-seize to shaft. Secure to bolt plates with 3/4" x 2-3/4" bolts, lockwashers and locknuts. Install Reinforcement Angles (8P5080) between bottom attach holes on inside of bolt plates.
- CR5. Install Snap Rings.

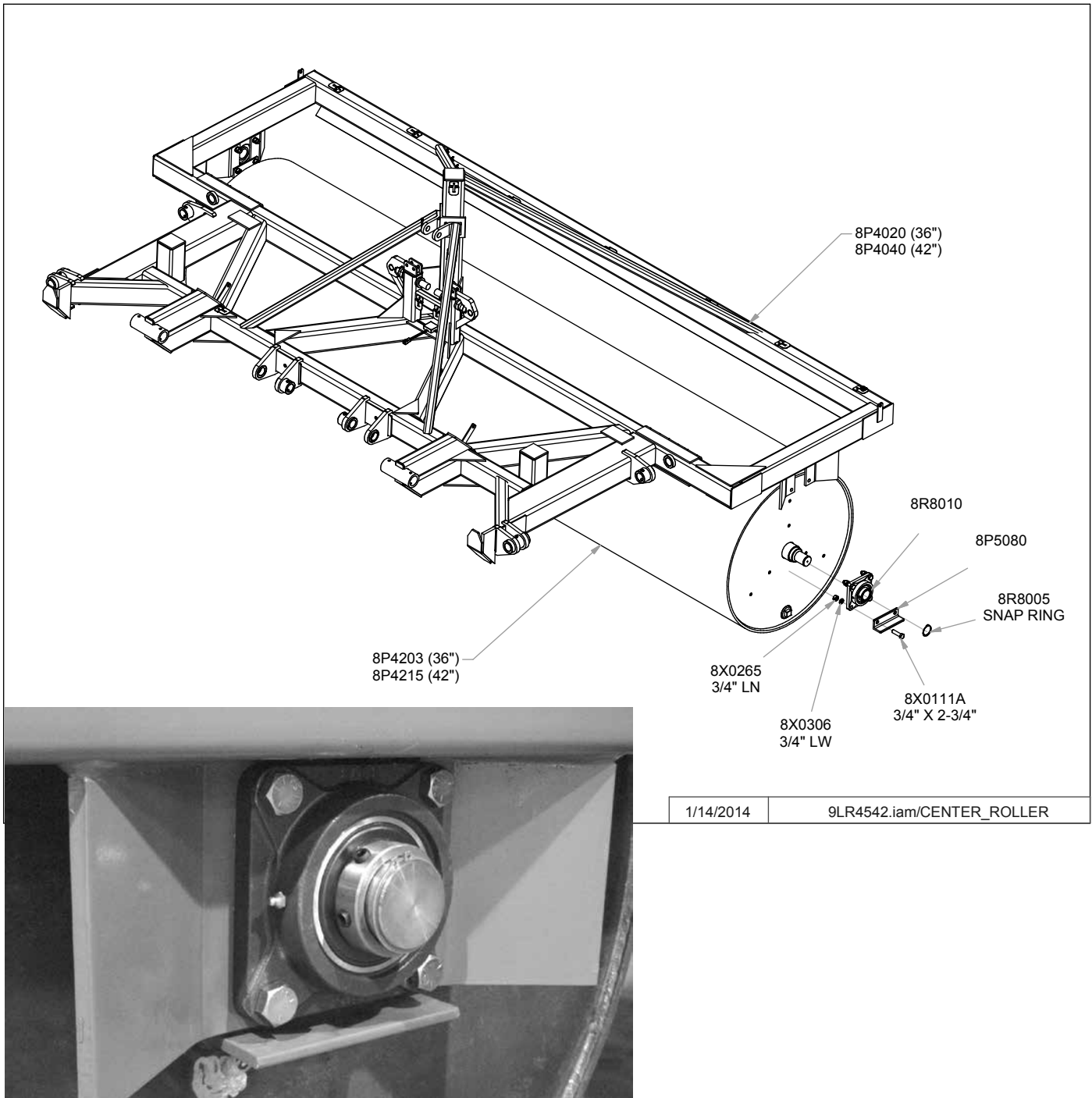

SECTION 2 - ASSEMBLY

SET-UP OF HITCH AND CENTER FRAMES

- F1. Install two outside hub assemblies ONLY. Apply good quality anti-seize to axles before installation. Retain axles into receiver tube with 1/2" x 4-1/2" bolt and locknut. Install Wheel and Tire assemblies on outside hubs. Torque wheel nuts to 240 FT-LB.
- F2. Lower tires to ground. Align Hitch to Center. Connect with 2" x 11" pins. Secure pins with 5/8" x 5" bolts, washers and locknuts.
- F3. Install inside hub, wheel and tire assemblies following procedure in step F1 and as shown in P-F1.
- F4. Install remaining components as shown.
- F5. Set Cylinder Attach Eye Bolts at mid adjustment, as shown in P-F2. Final adjustments will be made after Wings are installed.

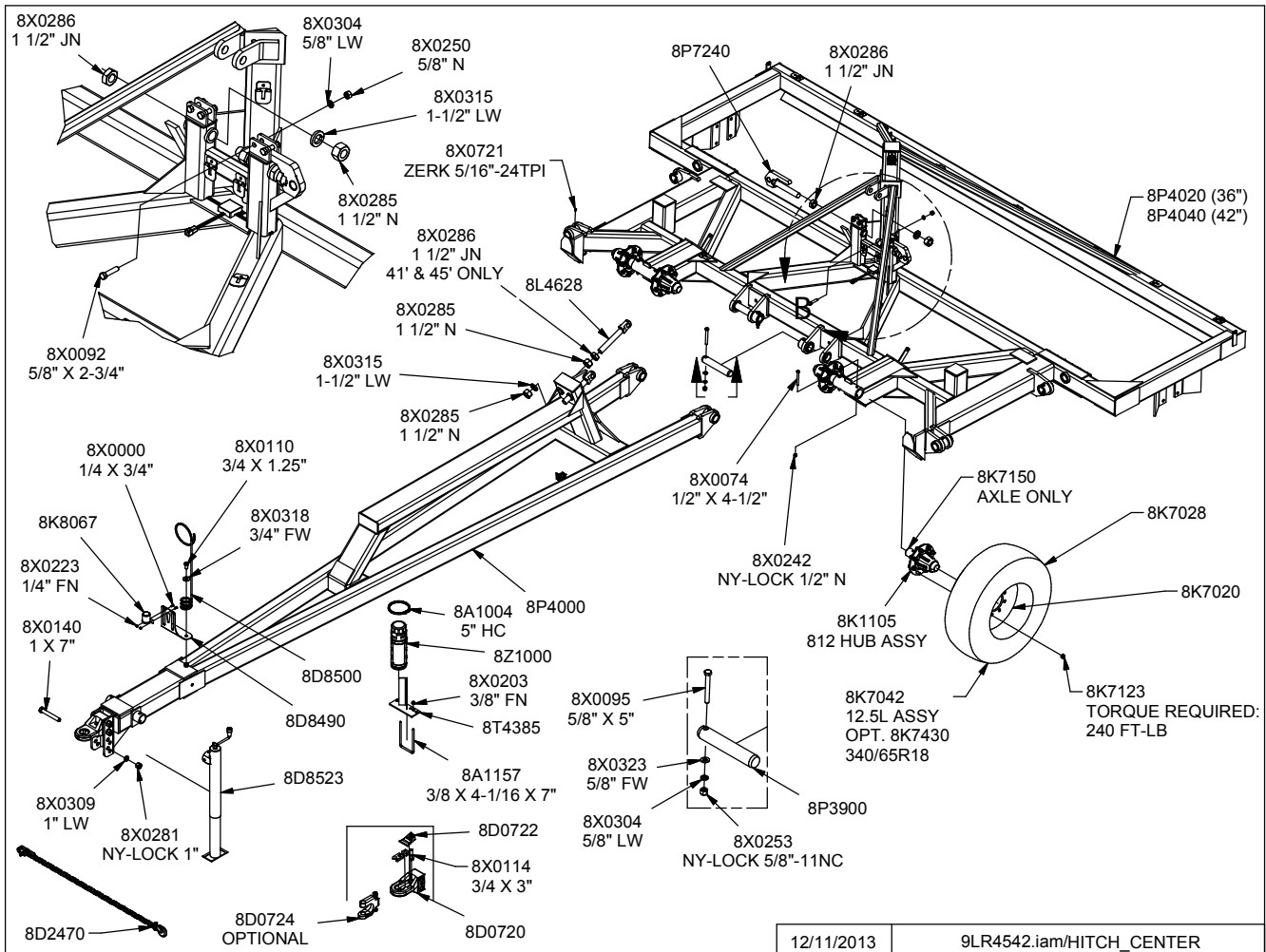

P-F1

P-F2
45' LR w/Jam Nut & Full Nut next to Pin (shown). Use Full Nut ONLY on 50' LR.

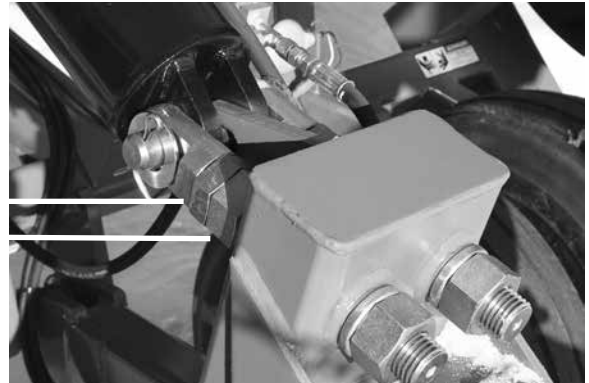

SET-UP OF TRANSPORT REST

TR1. Install Transport Rest components as shown.

- a. Do not tighten 8X0111A Set Bolts. These will be adjusted after Wings are installed
- b. Position front 8P5060 against Upright. Tighten U-bolt. Position and hand tighten rear 8P5060. Insert 1" x 5" bolts through front 8P5060, loop end of Safety Chains and rear 8P5060. Fully tighten 1" locknut and U-bolt for rear 8P5060.
- c. Store hook end of Safety Chains (8D2440) in Snap Rings (8R8005).

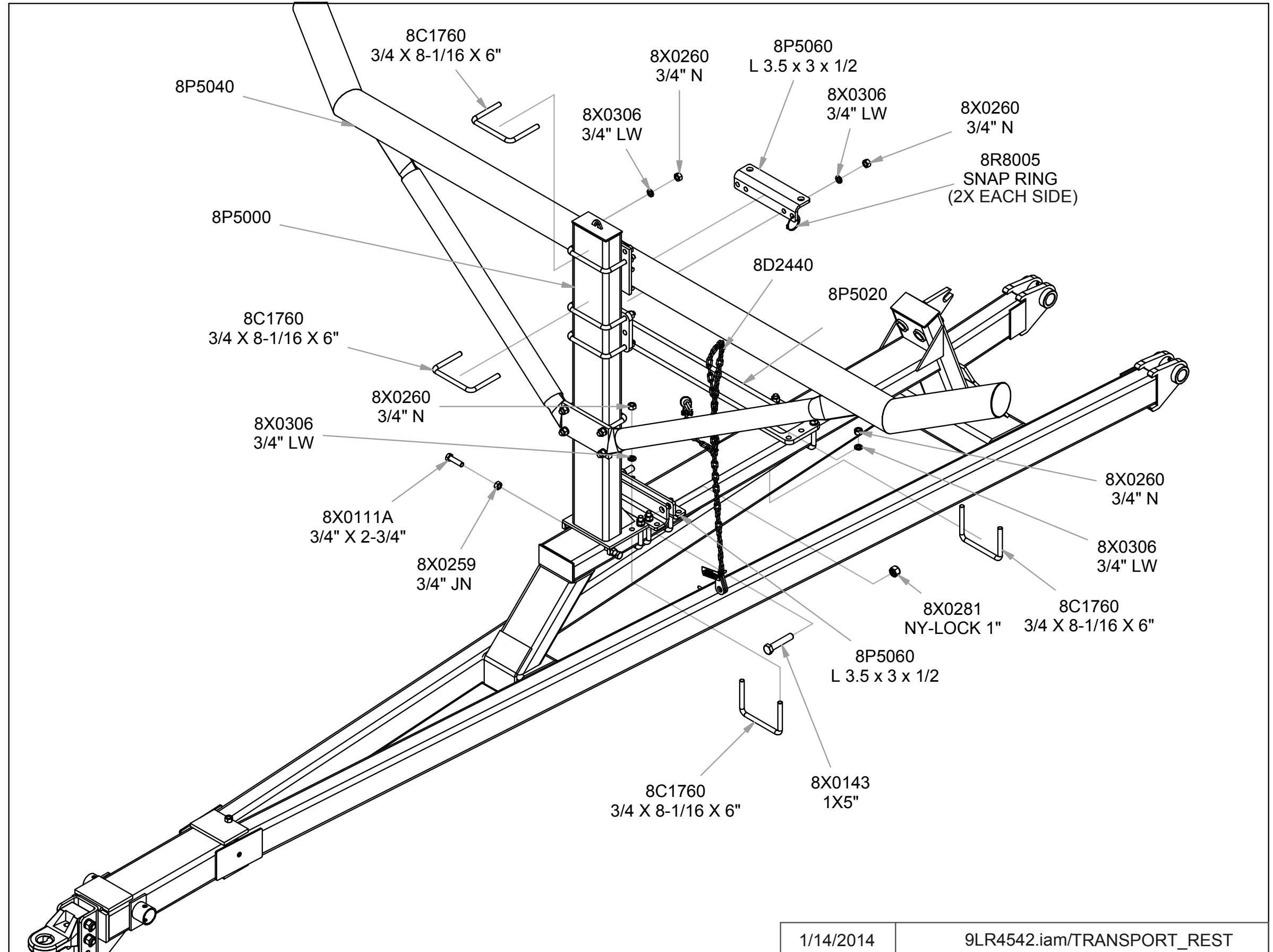
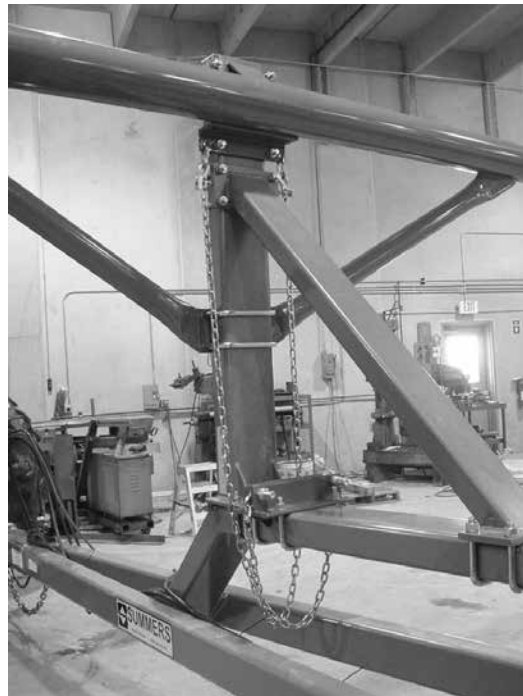

1/14/2014

9LR4542.iam/TRANSPORT_REST

SECTION 2 - ASSEMBLY

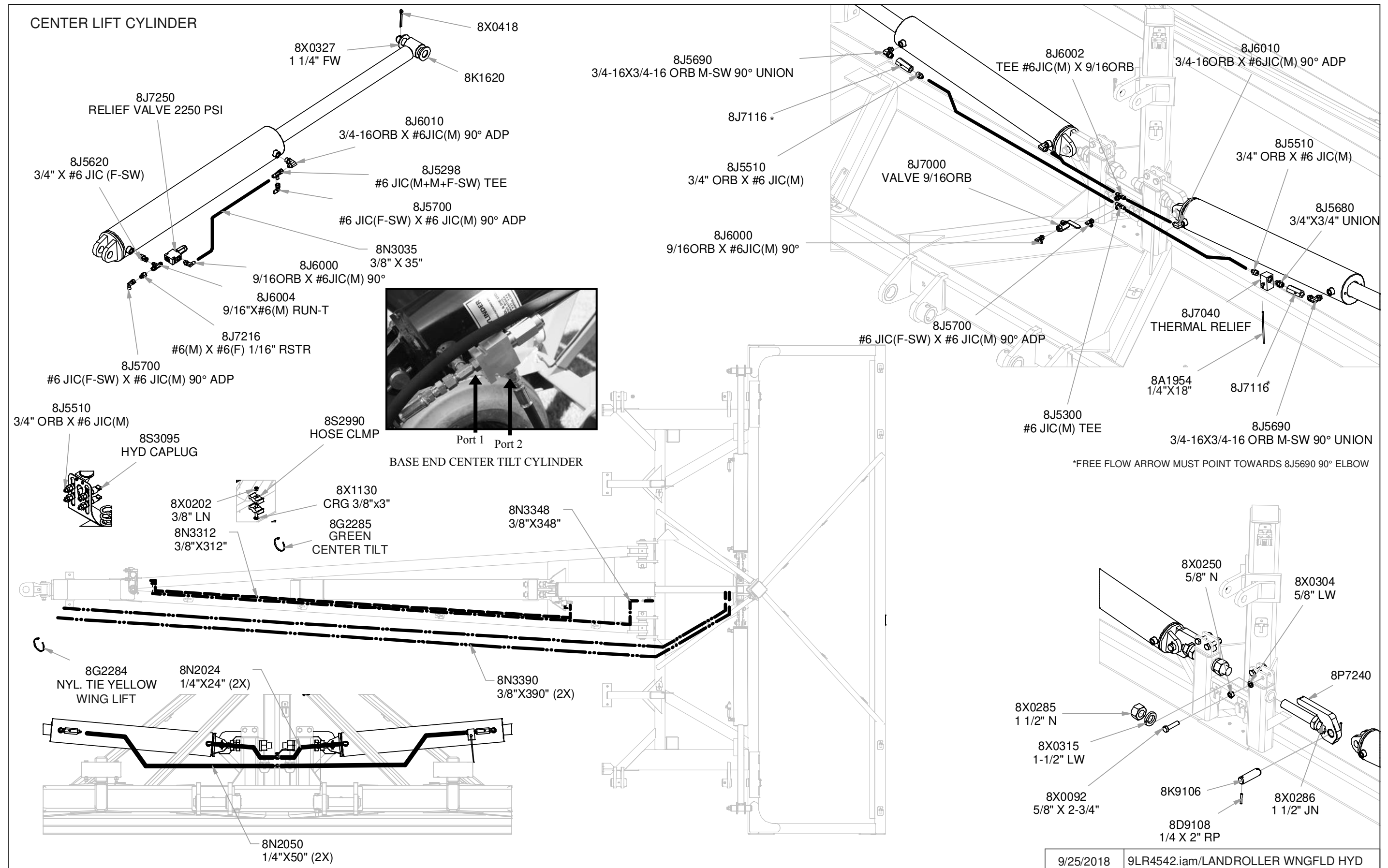

9/25/2018 9LR4542.iam/LANDROLLER WNGFLD HYD

SECTION 2 - ASSEMBLY

H1. Install Hydraulic components as shown.

- Leave enough slack at hitch pivot to allow folding machine without stretching or pinching hydraulic hoses.
- Secure with nylon ties and clamps provided. Do not over tighten clamps.

H2. Block hydraulic cylinders so rods can extend 32" without contacting any obstructions. Fully extend and retract cylinders 3 times to insure all air is purged from system.

	<p style="text-align: center;"> WARNING</p> <p>HIGH-PRESSURE FLUID HAZARD To prevent serious injury or death:</p> <ul style="list-style-type: none">•Relieve pressure on system before repairing or adjusting or disconnecting.•Wear proper hand and eye protection when searching for leaks. Use wood or cardboard instead of hands.•Keep all components in good repair. <p style="text-align: right;">SW700</p>
---	--

H3. Connect Rod End of Center Tilt Cylinder to Center Clevis as circled in P-H1 and P-H2.

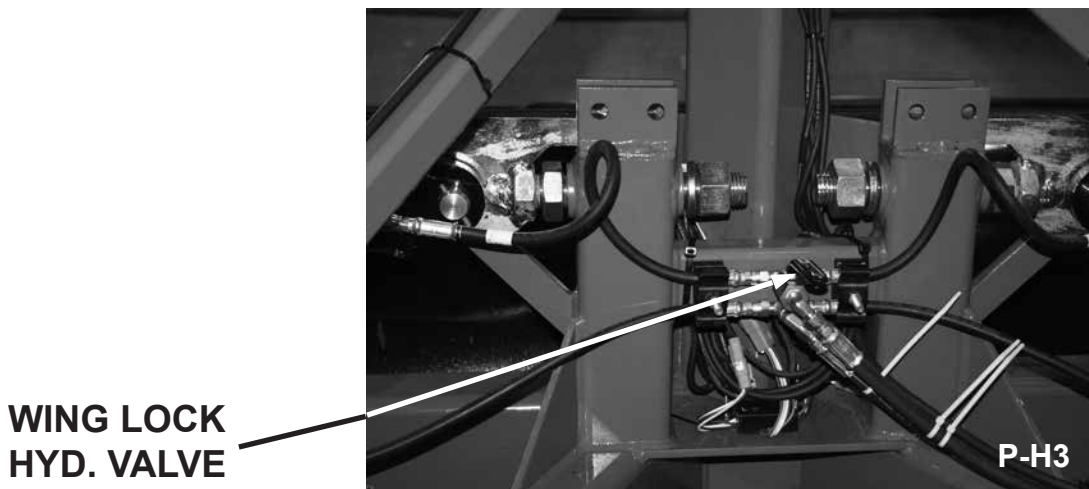

SECTION 2 - ASSEMBLY

WING INSTALLATION

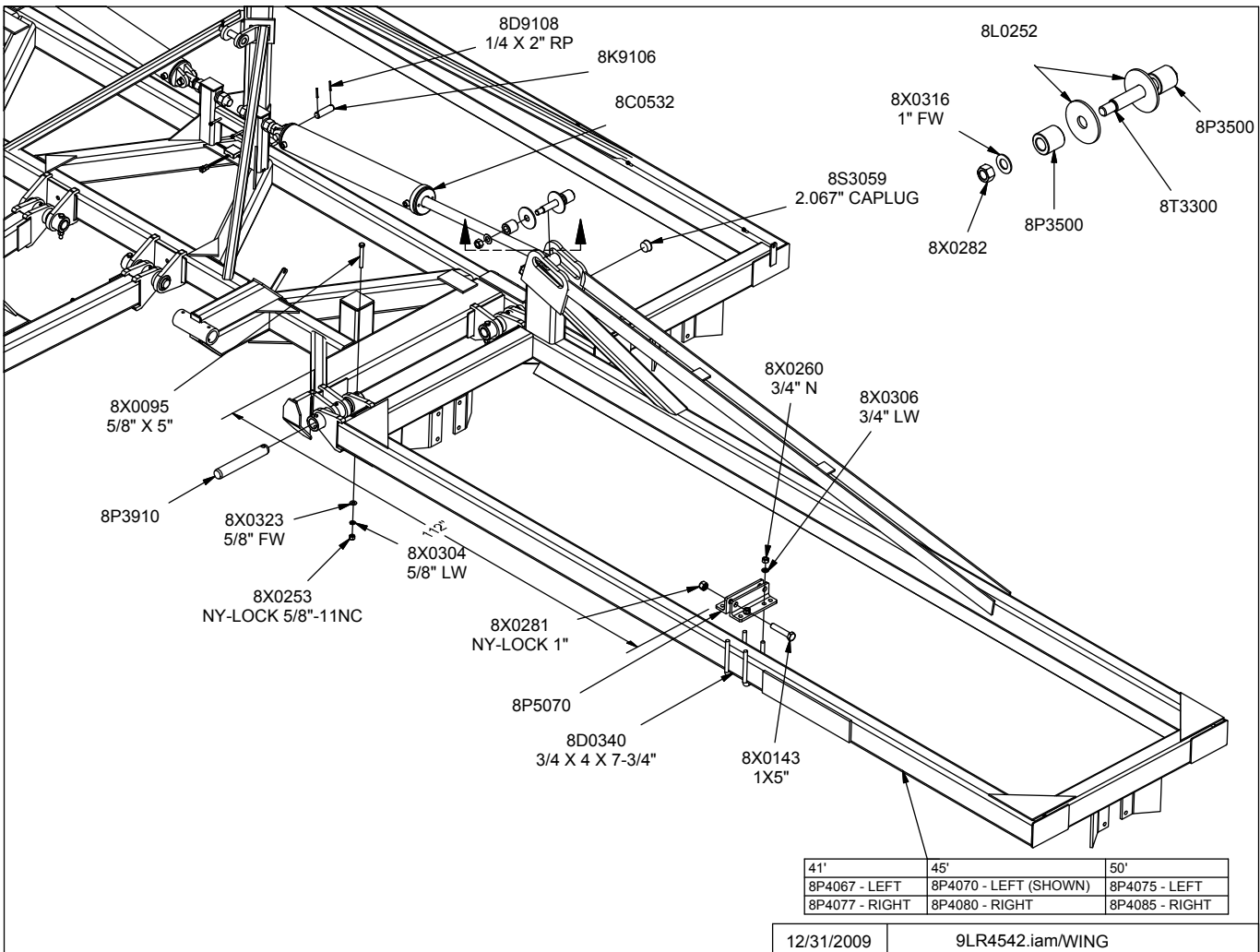

- W1. Connect Left and Right Wings with 2" x 13-1/2" Pins. Position retaining holes in the inside of pivots. Retain pins with 5/8" x 5" bolts, washers and nuts.
- W2. Connect rod end of wing lift cylinders as shown. Do Not Overtighten Pivot Bolt (8T3300). Pivot Bolt must be free to rotate (see photo P-W1).
- W3. Steps to adjust Cylinder Attach Eye Bolts:
 - a. Grease Zerks on Wing and Center pivots.
 - b. Raise Wings by retracting Wing Lift Cylinders.
 - c. Adjust Wing Lift Cylinder Eye Bolts so wing stop rests on center section when cylinders are fully retracted (see photo P-W3).
 - d. With Wings folded up tilt machine forward by retracting Center Tilt Cylinder.
 - e. Adjust Center Tilt Cylinder Eye Bolt so wings rest on Transport Rest when cylinder is fully retracted (see lower photo page 2-14).
 - f. Lower machine to Field Position.
- W4. Install Wing Locks at location shown. Tighten 1" Lock Nut until one thread is past nylon lock. Distance between 8P5070 is required for Safety Chain to pass through.
- W5. Install 8S3059 Plugs behind rear pivot pins (see photo P-W2).

SECTION 2 - ASSEMBLY

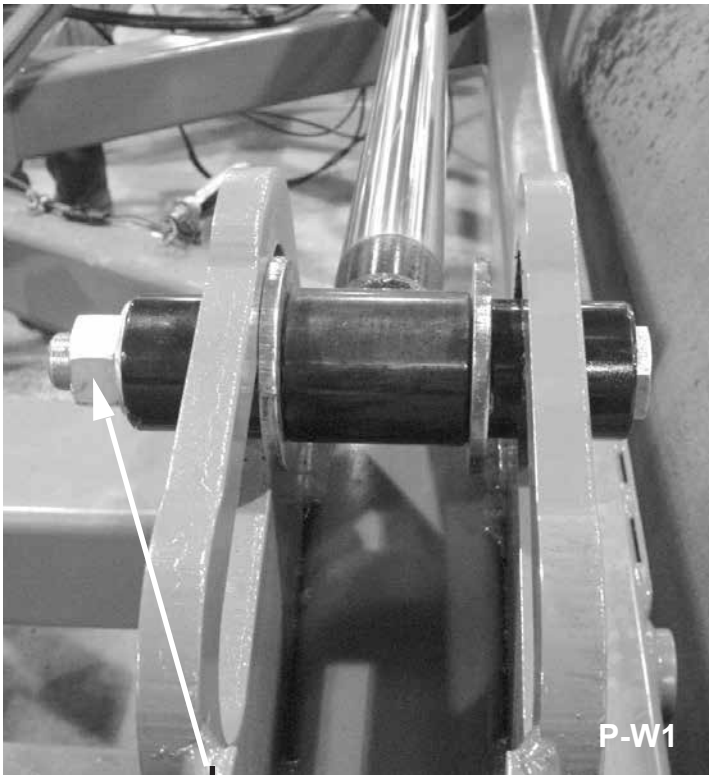

P-W1

**DO NOT OVER TIGHTEN.
PIVOT BOLT MUST BE FREE TO ROTATE.**

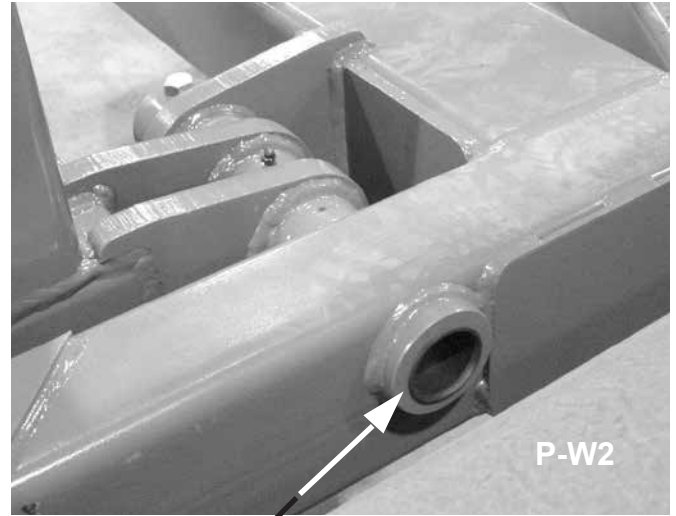

P-W2

**8S3059
PLUG**

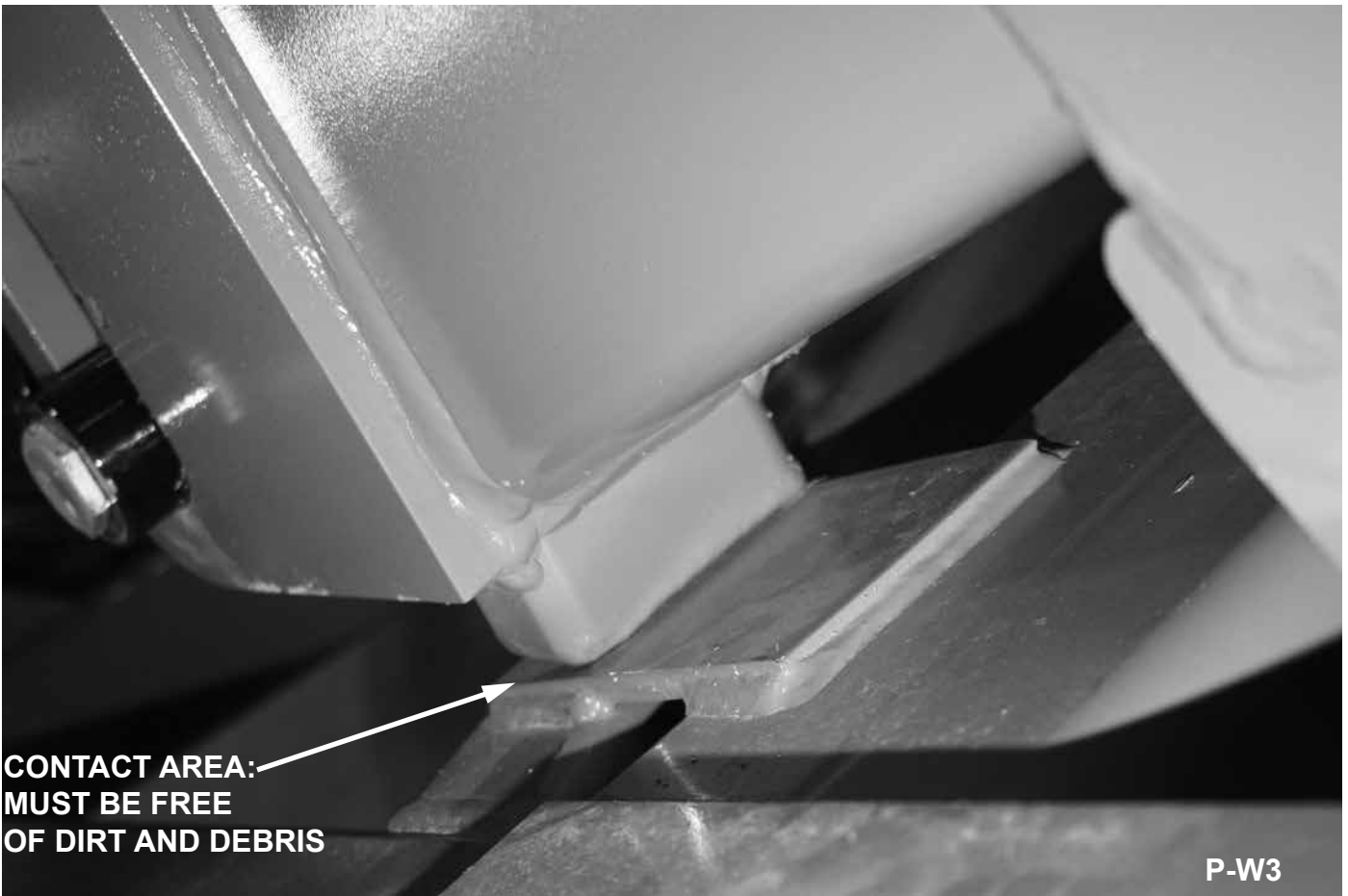

**CONTACT AREA:
MUST BE FREE
OF DIRT AND DEBRIS**

P-W3

SECTION 2 - ASSEMBLY

WING ROLLER INSTALLATION

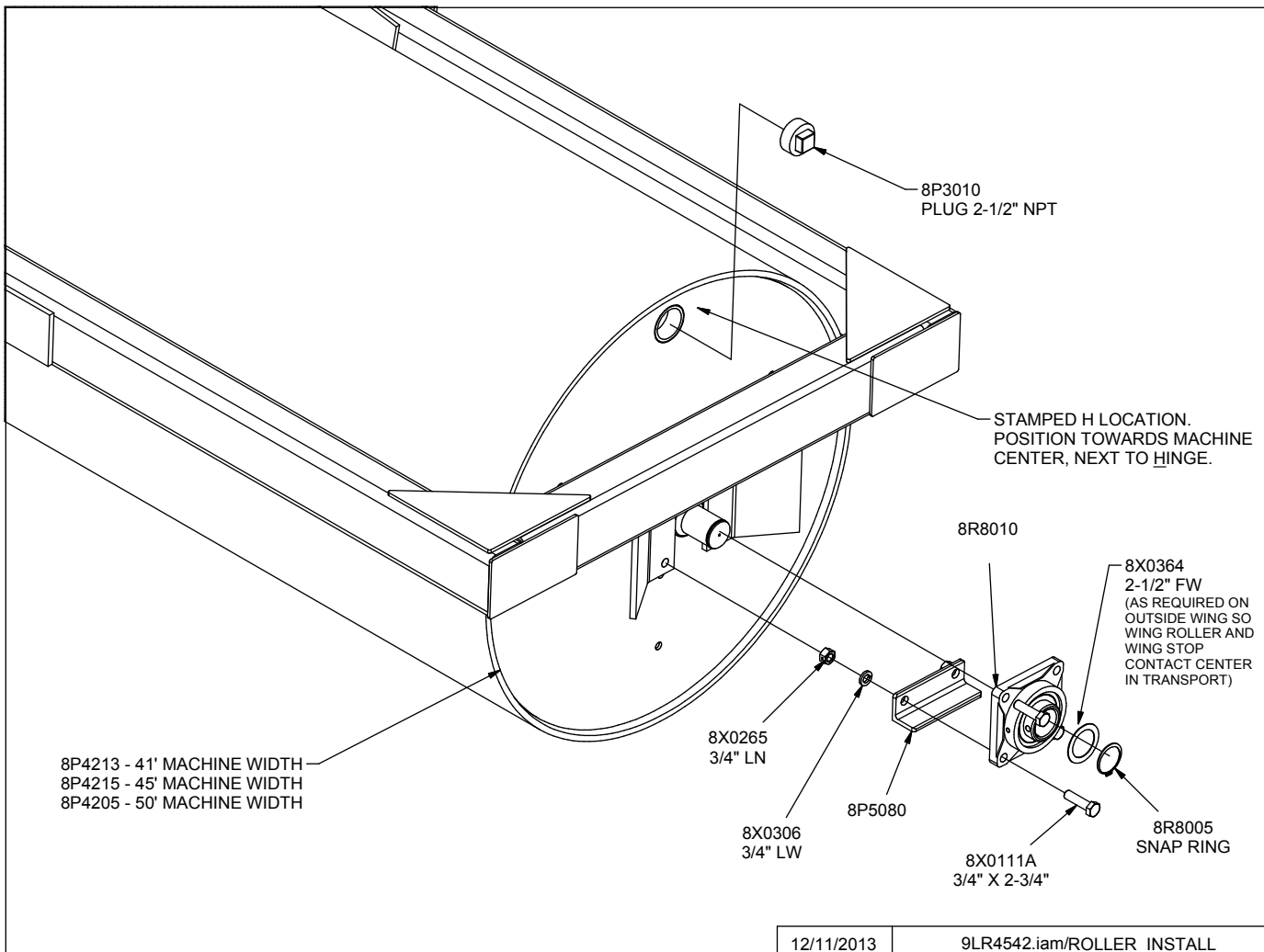

WR1. Clean Roller pivot shafts.

WR2. Position Rollers below Wings. CAUTION: Each Roller weighs up to 4285#, block to prevent unexpected movement. Be careful when moving them. Use extreme caution when centering on frame.

WR3. NOTE: An H has been stamped onto one end of each roller, position this H next to the Wing Hinge.

WR4. Install Bearings with grease zerk towards rear of machine. Apply anti-seize to shaft. Secure to bolt plates with 3/4" x 2-3/4" bolts, lock washers and locknuts. Install Reinforcement Angles between bottom attachment holes on inside of the bolt plate.

WR5. On the outside bearings only, install 2-1/2" ID flat washers before installing snap ring. Install Snap Rings (8R8005). Adjust quantity of 2-1/2" ID flat washers so Wing Stop and Roller contact Center at same time. See page 3-7.

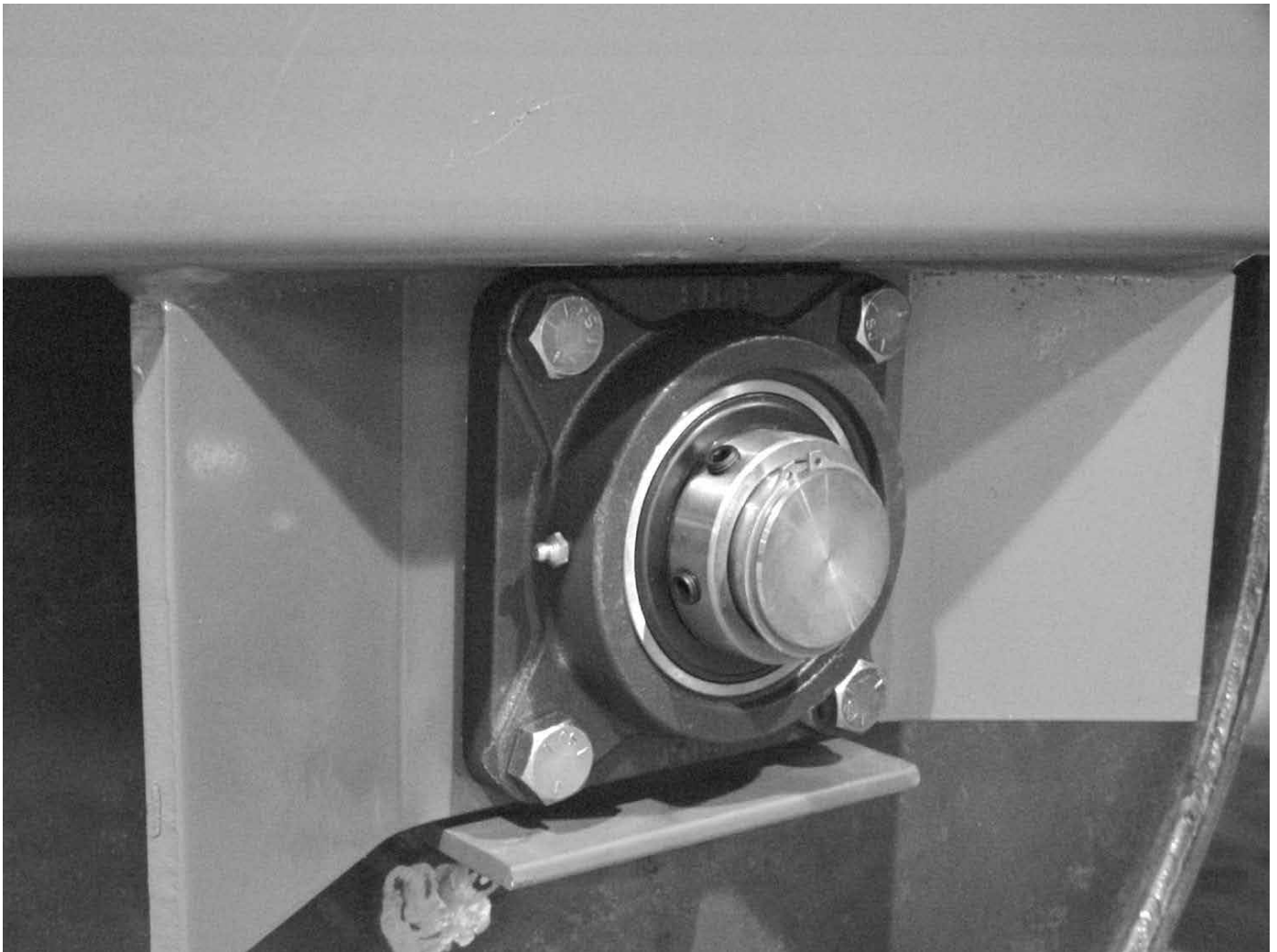

FOLD AND UNFOLD LAND ROLLER WITH ROLLERS INSTALLED:

1. See Page 3-5 for STEPS REQUIRED TO FOLD FROM FIELD TO TRANSPORT POSITION. Follow these steps.
2. See Page 3-3 for STEPS REQUIRED TO UNFOLD FROM TRANSPORT TO FIELD POSITION. Follow these steps.

NOTE: To prevent rust, spray paint Bearings and Roller Shaft after assembly is complete.

SECTION 2 - ASSEMBLY

SAFETY LIGHT & DECAL INSTALLATION

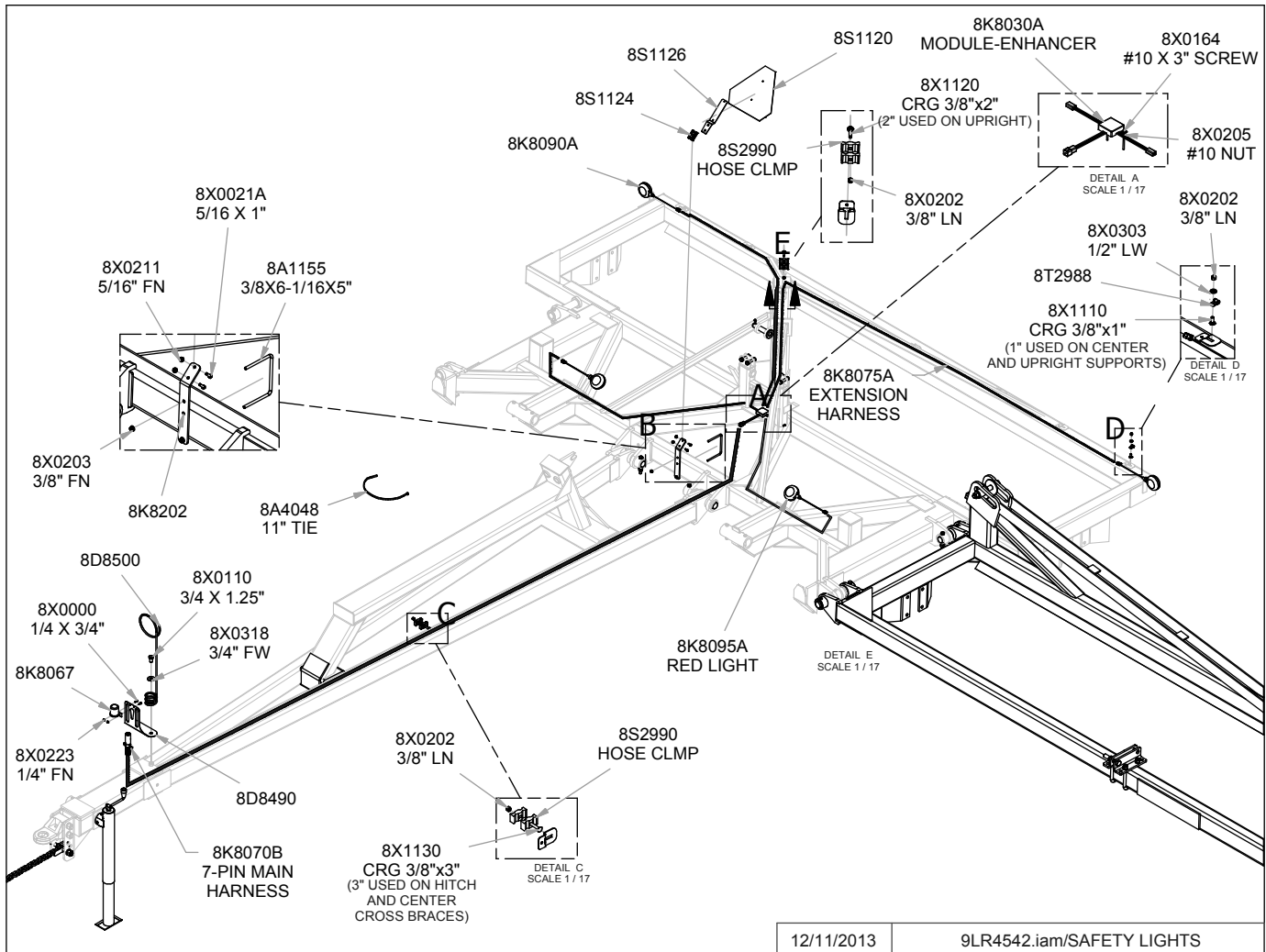

- S1. Install Safety Light Kit and SMV Sign as shown.
 - a. Leave slack at Hitch Pivot to allow folding machine without stretching or pinching wire harness.
 - b. Secure wire harness with clamps and nylon ties provided.
- S2. Attach Decals at locations shown on page 1-6.



SECTION 2 - ASSEMBLY



ASSEMBLY COMPLETE



SECTION 3 – OPERATION

LAND ROLLER OPERATION SAFETY



1. READ AND UNDERSTAND Operator's Manual before using machine. Review at least annually thereafter.
2. VERIFY that all safety devices and shields are in place before using machine.
3. KEEP hands, feet, hair and clothing away from moving parts.
4. STOP engine, place all controls in neutral, set parking brake, remove ignition key and wait for all moving parts to stop before servicing, adjusting, maintaining or unplugging.
5. BE CAREFUL when working around high pressure hydraulic system.
6. ALWAYS make sure Land Roller is lowered into field position (cylinders extended), is blocked to prevent movement and that pressure is relieved from hydraulic circuits before servicing.
7. DO NOT ALLOW RIDERS.
8. USE EXTREME CARE when making adjustments.
9. KEEP CHILDREN AWAY from machinery at all times.
10. NEVER ALLOW anyone to walk or work under Land Roller wings or center section.
11. WARNING – DO NOT ATTEMPT to raise machine into transport position if mud has built up on rollers or if machine weight has been increased by any other means. Mechanical failure may occur.

STEPS PRIOR TO OPERATION:

1. COMPLETE WARRANTY REGISTRATION CARD.
 - A. Complete and return WARRANTY REGISTRATION CARD located at the beginning of this manual. Returning this card entitles you to a free gift.
 - B. Complete the OWNER REGISTER also located at the beginning of this manual (Serial Number is located by the front of the hitch). Owner register information may be needed when ordering parts.
2. VERIFY TRACTOR REQUIREMENTS.
 - A. WARNING: Land Roller must be attached directly to tractor drawbar and not an intermediate towed vehicle or implement. Loss of control could result causing serious injury or death to you or others.
 - B. Ability to safely operate the Summers Land Roller is determined by both tractor horsepower and weight. The minimum tractor weight for operating this implement is 16,000 lbs. Minimum tractor engine horsepower is 160. Dual tires or single tires set at maximum width are required for safe operation of the Land Roller.
 - C. The Summers Land Roller must be connected to a tractor drawbar with a locked draw pin. The tractor drawbar must be able to withstand 2000 lb. of tongue weight during transport (2200 lb. for 50') and 2000 lb. tongue lifting force while folding in and out of transport position.

SECTION 3 – OPERATION

INITIAL HOOKUP:

		<p> DANGER</p> <p>FRAME PINCH POINT HAZARD <i>KEEP AWAY</i></p> <p>To prevent serious injury or death from crushing:</p> <ul style="list-style-type: none">• Stay away from frame hinge area when folding wings.• Keep others away.• Do not fold wings when bystanders are present. <p>8Z0087</p>
---	---	---

1. Make tractor to hitch connection with locking draw pin and safety chain.
2. Retract jack and rotate into storage position.
3. Insure that tips and couplers are CLEAN. Plug Center Tilt Cylinder hoses into desired tractor outlet. Adjust hydraulic flow rate to 35% of maximum.
4. Plug Wing Lift Cylinder hoses into desired tractor outlet. Adjust hydraulic flow rate to 35% of maximum.
5. Connect safety Light Kit wiring harness to 7 pin receptacle.
6. If Land Roller is in Transport Position, follow “Steps Required to Unfold from Transport to Field Position”, page 3-3.
7. INITIAL CHECK – with machine in Field Position
 - A. After receiving or assembling your Land Roller, it is a good practice to double check the entire machine so all fasteners are securely tightened.
 - B. Make sure all grease fittings are in place and greased properly.
 - C. Inflate tires to recommended inflation pressure (see page 4-2), check that wheel nuts are tightened to 240 ft-lb and check that wheel bearings are correctly adjusted.

NOTE: The first time the Land Roller is folded into Transport Position and after any machine adjustment, it is very important to follow “STEPS REQUIRED TO FOLD FROM FIELD TO TRANSPORT POSITION”, page 3-5. In addition to these steps, it is very important to retract hydraulic cylinders slowly to insure Cylinder Attach Eye Bolts are correctly adjusted and that hydraulic hoses and wires are not stretched or pinched.

SECTION 3 – OPERATION

STEPS REQUIRED TO UNFOLD FROM TRANSPORT TO FIELD POSITION:

1. **WARNING:** Land Roller must be attached directly to tractor drawbar and not an intermediate towed vehicle or implement. Loss of control could result causing serious injury or death to you or others.
2. Ability to safely operate the Summers Land Roller is determined by both tractor horsepower and weight. The minimum tractor weight for operating this implement is 16,000 lb. Minimum tractor engine horsepower is 160. Dual tires or single tires set at maximum width are required for safe operation of the Land Roller.
3. The Summers Land Roller must be connected to a tractor drawbar with a locked draw pin. The tractor drawbar must be able to withstand 2000 lb of tongue weight during transport (2200 lb. for 50') and 2000 lb tongue lifting force while folding in and out of transport position.
4. Park tractor and Land Roller on a firm level surface with enough open area that will allow unfolding Land Roller without contacting obstructions. **WARNING:** Land Roller height increases to:

MACHINE WIDTH	FOLDING MAXIMUM MACHINE HEIGHT
41'	17'
45'	18'9"
50'	21'6"

during fold and unfold sequence, insure that wings will not contact overhead obstructions.

5. Unhook Wing Safety Lock Chains. Hook Chains onto storage rings located below Transport Cross Tube. Open wing lock hydraulic valve.

DANGER



TO AVOID INJURY OR DEATH STAND CLEAR OF MACHINE WHEN WINGS AND CENTER ARE BEING RAISED OR LOWERED. MECHANICAL OR HYDRAULIC FAILURE MAY OCCUR WHICH WILL ALLOW ROLLERS TO FALL RAPIDLY.



NEVER ALLOW ANYONE TO WALK OR WORK UNDER LANDROLLER WINGS OR CENTER SECTION.

WHEN MACHINE IS IN TRANSPORT POSITION, WALK AND WORK IN GREEN AREA ONLY.

INSTALL WING TRANSPORT SAFETY CHAINS AND CLOSE WING LOCK HYDRAULIC VALVE BEFORE TOWING.

20 MPH MAXIMUM TRANSPORT SPEED.

8Z0106

SECTION 3 – OPERATION

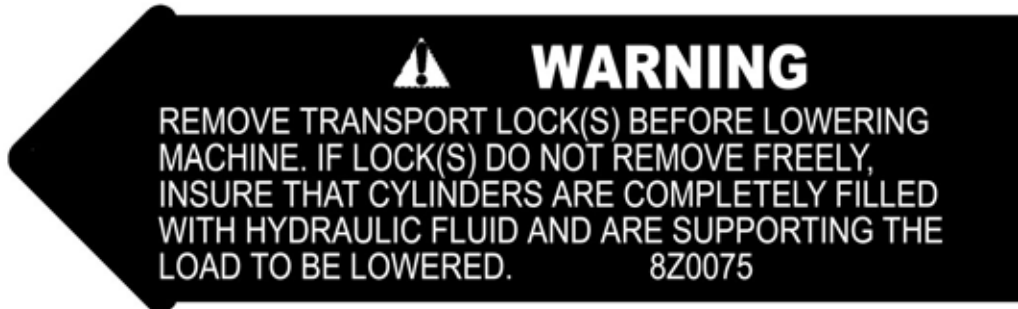

6. Operate tractor hydraulics from operator station only. Do not allow anyone to stand near Land Roller when folding or unfolding. Do not raise or lower Land Roller when implement is moving.
7. Fully extend Center Tilt Cylinder, Wings will rotate rearward, maintain hydraulic pressure an additional 5 seconds to insure cylinder and hoses are fully charged with oil. Retract Center Tilt cylinder approximately 1/2".
8. Lower wings with caution by fully extending Wing Lift cylinders.

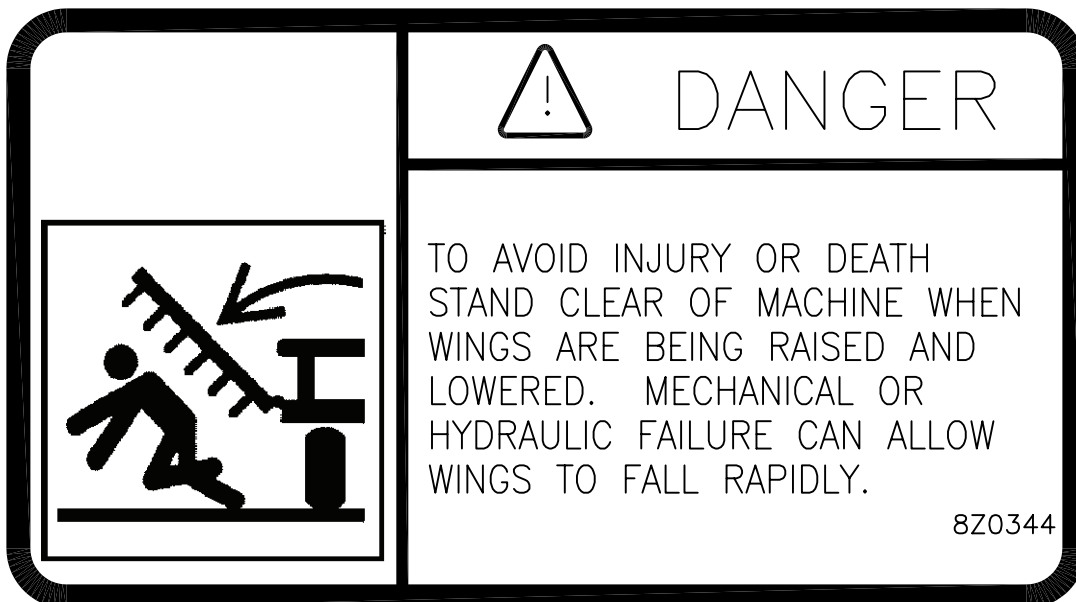

IMPORTANT:

Two one-way restrictors are installed in the Wing lowering hydraulic circuit. These restrictors reduce the chance of Wing free fall. Do Not remove these restrictors!

SECTION 3 – OPERATION

LAND ROLLER FIELD OPERATION:

1. If Land Roller is in Transport Position, follow “Steps Required to Unfold Land Roller from Transport to Field Position”, page 3-3.
2. When in field position, place Center Tilt Cylinder remote into float position. This will allow rollers to self level.
3. Choose an operating speed which achieves desired results. Operating at over 7 MPH will decrease effectiveness and increase chance of immovable rocks denting roller tube. Denting of roller tube is NOT covered by warranty.

STEPS REQUIRED TO FOLD FROM FIELD TO TRANSPORT POSITION:

1. **WARNING:** Never tow this implement with less than a 16,000 lb vehicle.
2. The Summers Land Roller must be connected to a tractor drawbar with a locked draw pin. The tractor drawbar must be able to withstand 2000 lb of tongue weight during transport (2200 lb. for 50') and 2000 lb tongue lifting force while folding in and out of transport position.
3. Park tractor and Land Roller on a firm level surface with enough open area that will allow folding Land Roller without contacting obstructions. Land Roller height increases to:

MACHINE WIDTH	FOLDING MAXIMUM MACHINE HEIGHT
41'	17'
45'	18'9"
50'	21'6"

during fold and unfold sequence, insure that wings will not contact overhead obstructions. Operate tractor hydraulics from the operator station only. Do not allow anyone to stand near Land Roller when folding or unfolding.

4. **WARNING: DO NOT ATTEMPT to raise machine into transport position if mud has built up on rollers or if machine weight has been increased by any other means.**

5. Fully extend Center Tilt cylinder, maintain hydraulic pressure an additional 5 seconds to insure the cylinder and hoses are fully charged with oil. Retract Center Tilt cylinder approximately 1/2”.
6. Raise wings with caution by retracting Wing Lift cylinders. Reduce cylinder retract speed when wings are near transport position.
7. Fully retract Center Tilt cylinder, Wings will rotate forward and must rest on Transport Cross Tube.

IMPORTANT: If Wings do not rest on Transport Cross Tube or if there is additional cylinder stroke after Wings contact Transport Cross Tube, follow “STEPS REQUIRED TO UNFOLD FROM TRANSPORT TO FIELD POSITION” page 3-3 and “PROCEDURE TO ADJUST CYLINDERS” page 3-6.

8. Install Wing Safety Lock Chains and close wing lock hydraulic valve.

 **DANGER**



TO AVOID INJURY OR DEATH STAND CLEAR OF MACHINE WHEN WINGS AND CENTER ARE BEING RAISED OR LOWERED. MECHANICAL OR HYDRAULIC FAILURE MAY OCCUR WHICH WILL ALLOW ROLLERS TO FALL RAPIDLY.



NEVER ALLOW ANYONE TO WALK OR WORK UNDER LANDROLLER WINGS OR CENTER SECTION.

WHEN MACHINE IS IN TRANSPORT POSITION, WALK AND WORK IN GREEN AREA ONLY.

INSTALL WING TRANSPORT SAFETY CHAINS AND CLOSE WING LOCK HYDRAULIC VALVE BEFORE TOWING.

20 MPH MAXIMUM TRANSPORT SPEED.

820106

SECTION 3 – OPERATION

PROCEDURE TO ADJUST HYDRAULIC CYLINDER ATTACH EYE BOLTS:

Refer to the drawing and photo on next page before adjusting Attachment Eye Bolts. Follow these steps:

1. Adjust Wing Lift Cylinder Eye Bolts FIRST. Adjust Eye Bolts so Wing Stop and Roller rest on Center contact areas when Wing Lift Cylinder is fully retracted.
 - a. If Wing does not contact Center, lower wing, relieve hydraulic pressure and adjust Eye Bolt towards machine center line.
 - b. If Wing contacts Center before Wing Lift Cylinder is fully retracted, lower wing, relieve hydraulic pressure and adjust Eye Bolt away from machine center line.
 - c. If Wing Stop and Roller do not contact Center at same time, adjust quantity of 2-1/2" flat washers (8X0364) on outside Roller Shaft. See page 2-10.

NOTE: Dirt and debris must be cleared from contact area on Center before folding into transport position. Dirt and debris in this area can prevent wing from folding correctly.

2. Next adjust Center Tilt Cylinder Eye Bolt. Adjust Eye Bolt so Wings contact Transport Rest Cross Tube when Cylinder is fully retracted. Either Roller Tube or Wing Frame can make contact.
 - a. If Wings do not contact Cross Tube, lower machine into field position, relieve hydraulic pressure and adjust Eye Bolt forward.
 - b. If Wings contact Cross Tube before Center Tilt Cylinder is fully retracted, lower machine into field position, relieve hydraulic pressure and adjust Eye Bolt rearward.
 - c. If enough thread is exposed on the hole end of the Eye Bolt, locate 1-1/2" Jam Nut next to cylinder to provide additional support.
 - d. If required the Upright can be adjusted towards the front or back OR the Cross Tube can be adjusted up or down to allow Wings to fold correctly.

IMPORTANT: Hydraulic pressure must be relieved from cylinders before adjusting eyebolts. With Land Roller in Field Position; shut off tractor, engage parking brake and relieve hydraulic pressure by cycling remote lever.

IMPORTANT: When Cylinder Attach Eye Bolts are tightened insure that cylinder pins are aligned. Misaligned cylinder pins will create additional stress on hydraulic cylinders causing premature failure which can create a potentially hazardous situation.

NOTE: After any machine adjustment, it is very important to follow "STEPS REQUIRED TO FOLD FROM FIELD TO TRANSPORT POSITION", page 3-5. In addition to these steps, it is very important to retract hydraulic cylinders slowly to insure Cylinder Attach Eye Bolts are correctly adjusted and that hydraulic hoses and wires are not stretched or pinched.

SECTION 3 – OPERATION

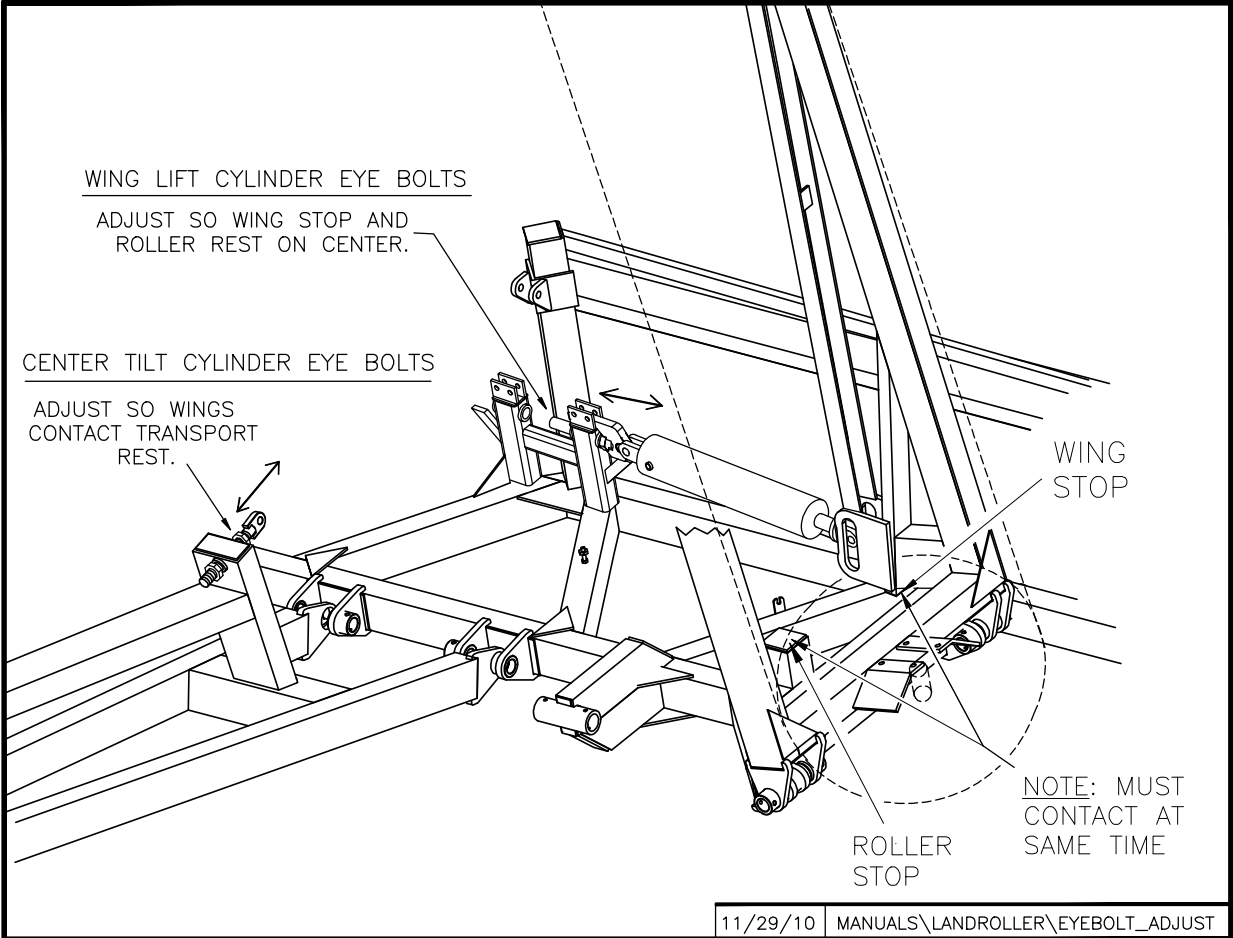

SECTION 3 – OPERATION

TRANSPORTING LAND ROLLER:

1. If Land Roller is in Field Position, follow “Steps Required to Fold Land Roller from Field to Transport Position”, page 3-5.
2. Ability to safely operate the Summers Superroller is determined by both tractor horsepower and weight. The minimum tractor weight for operating this implement is 16,000 lbs. Minimum tractor engine horsepower is 160. Dual tires or single tires set at maximum width are required for safe operation of Land Roller.
3. ONLY TOW at a safe speed – 20 MPH MAXIMUM. Use caution when making corners or meeting traffic.
4. USE Safety Lights and Safety Chain between tractor drawbar and implement hitch when transporting on public roads.
5. ALWAYS install wing transport safety chains and close wing lock hydraulic valve before transporting on public roads.
6. FOLLOW ALL local laws governing transporting of farm machinery.
7. Use additional caution and reduce speed when towing under adverse conditions, when turning and when on unlevel surfaces.
8. Stay clear of overhead lines and other overhead obstructions.
9. Frequently check for traffic from rear, especially during turns.

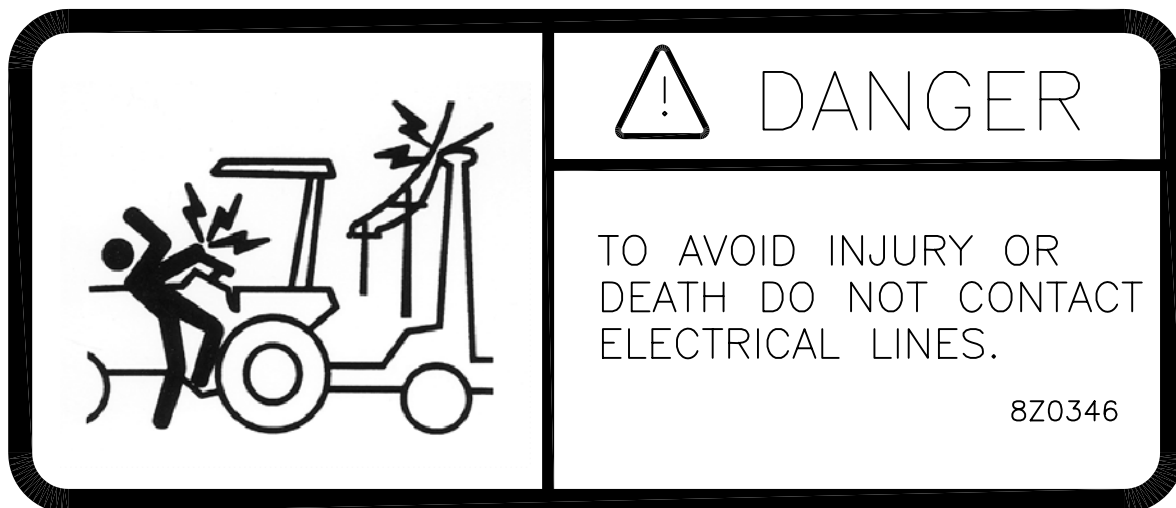

SECTION 3 – OPERATION

UNHOOKING LAND ROLLER FROM TRACTOR IN FIELD POSITION (HIGHLY RECOMMENDED):

1. **WARNING:** It is highly recommended to unhook Land Roller in Field Position **ONLY**. **NEVER** unhook Land Roller if positioned hydraulically between Field and Transport Position.
2. Choose a firm level surface with enough open area that will allow unfolding Land Roller without contacting any obstructions. If Land Roller is in Transport Position, follow “Steps Required to Unfold Land Roller from Transport to Field Position”.
3. With Land Roller in Field Position; shut off tractor, engage parking brake and relieve hydraulic pressure by cycling remote lever.
4. Block rollers to prevent movement after hitch pin is removed.
5. Check that hitch pin is not bound with sideways or front to back pressure. If hitch pin is not free, carefully reposition tractor.
6. Rotate jack into vertical position and extend jack until hitch piece lifts off tractor drawbar.
7. Disconnect wiring harness, hydraulic hoses and safety chain.
8. Recheck that hitch pin is free, if so, stand to the side of the hitch and remove hitch pin.
9. Carefully drive ahead.

UNHOOKING LAND ROLLER FROM TRACTOR IN TRANSPORT POSITION (NOT RECOMMENDED):

1. It is highly recommended to unhook Land Roller in Field Position **ONLY**. **NEVER** unhook Land Roller if positioned hydraulically between Field and Transport Position.
2. Wing weight of the Summers Land Roller transfers forward in Transport Position creating approximately 2000 LB of tongue weight (2200 lb. for 50'), keep this in mind and be careful when around Land Roller. **DO NOT ALLOW ANYONE TO WALK OR WORK UNDER LAND ROLLER WINGS OR CENTER SECTION.**
3. **ONLY IF ABSOLUTELY NECESSARY**, the Land Roller can be unhooked from tractor in Transport Position if the following precautions are taken.
 - A. Choose a very firm level surface.
 - B. Install Wing Safety Lock Chains and close wing lock hydraulic valve.



SECTION 3 – OPERATION

- C. Block tires to prevent movement after hitch pin is removed.
- D. Check that hitch pin is not bound with side or front to back pressure. If hitch pin is not free, carefully reposition tractor.
- E. With hitch pin free, if hitch piece lifts up on tractor drawbar, negative tongue weight exists. **DO NOT UNHOOK LAND ROLLER WITH NEGATIVE TONGUE WEIGHT.** Negative tongue weight can be caused by excessive ground slope (front of hitch higher than center section) or incorrect machine adjustment (wings not rotated far enough ahead to transfer weight to hitch piece). Relocate Land Roller to a more level surface, if negative tongue weight still exists, follow “STEPS REQUIRED TO UNFOLD FROM TRANSPORT TO FIELD POSITION” and adjust Land Roller to create adequate tongue weight.

NOTE: After any machine adjustment, it is very important to follow “STEPS REQUIRED TO FOLD FROM FIELD TO TRANSPORT POSITION”. In addition to these steps, it is very important to retract hydraulic cylinders slowly to insure Cylinder Attach Eye Bolts are correctly adjusted and that hydraulic hoses and wires are not stretched or pinched.

- F. If hitch piece is held up by tractor drawbar and can not be lifted off, positive tongue weight exists. If positive tongue weight exists, carefully follow steps G through J.
- G. Rotate jack into vertical position, place sturdy block under jack to distribute load over larger area and extend jack until hitch piece just lifts off tractor drawbar.
- H. Disconnect wiring harness, hydraulic hoses and safety chain.
- I. Recheck that hitch pin is free, if so, stand to the side of the hitch and remove hitch pin.
- J. Carefully drive ahead.

WARNING



LANDROLLER MUST BE SECURED TO AT LEAST A 16,000 LB AND 160 ENGINE HP TRACTOR DRAWBAR WITH A LOCKED HITCH PIN WHEN TRANSPORTING AND DURING FIELD OPERATION.

DO NOT ATTEMPT TO RAISE LANDROLLER INTO TRANSPORT POSITION IF MUD HAS BUILT UP ON ROLLERS OR IF MACHINE WEIGHT HAS BEEN INCREASED BY ANY OTHER MEANS. MECHANICAL OR HYDRAULIC FAILURE MAY OCCUR.

BLOCK MACHINE FROM ROLLING, LOWER HITCH JACK AND BE CERTAIN THAT NO UPWARD OR SIDE PRESSURE IS EXERTED ON TRACTOR DRAWBAR BEFORE DISCONNECTING.

8Z0104

SECTION 4 – MAINTENANCE

MAINTENANCE SAFETY

1. STOP engine, place all controls in neutral, set parking brake, remove ignition key and wait for all moving parts to stop before servicing, adjusting or maintaining.
2. BE CAREFUL when working around high pressure hydraulic system.
3. ALWAYS make sure that Land Roller is lowered into field position (cylinders extended), it is blocked to prevent movement and pressure is relieved from hydraulic circuits before servicing.
4. USE EXTREME CARE when making adjustments.
5. KEEP CHILDREN AWAY from machinery at all times.
6. NEVER ALLOW anyone to walk or work under Land Roller Wings or Center Section.



MAINTENANCE FOR AFTER THE FIRST TWO HOURS OF OPERATION

1. Grease wing and hitch pivots.
2. Check all hydraulic components for leaks. (SEE HIGH-PRESSURE FLUID WARNING ABOVE.)
3. Check tightness of wheel nuts. Recommended torque 240 ft.-lbs.
4. Check tightness of wheel bearings.
5. Check tightness of all hardware. Pay special attention to hitch and pivot pin retaining bolts.

DAILY MAINTENANCE

1. Grease wing and hitch pivots.
2. Check all hydraulic components for leaks. (SEE HIGH-PRESSURE FLUID WARNING ABOVE.)
3. Check tightness of all wheel nuts. Recommended torque 240 ft.-lbs.
4. Check tire air pressure. Recommended air pressure is 90 PSI for the 12.5Lx15LRF.

BALL BEARINGS ON ROLLERS: To maximize bearing life, grease bearings at mid day or end of day when bearings are at operating temperature. **Every 20 hours:** Add three strokes (approx. .14 oz.) of grease.

PERIODIC MAINTENANCE

1. Repack wheel bearings and check tightness (See Page 5-8).
2. Check the tightness of all hardware. Pay special attention to hitch and pivot pin retaining bolts.
3. Check Land Roller for damaged or worn parts. Replace as needed.

SECTION 4 – MAINTENANCE

STORAGE

1. Follow steps outlined in “UNHOOKING LAND ROLLER FROM TRACTOR IN FIELD POSITION”.
2. Clean and remove all excessive dirt and grease from Land Roller.
3. Grease all zerks.
4. To prevent rusting, repaint any areas that have been worn, chipped or scratched.
5. Apply grease* to any exposed part of cylinder shafts.

*NOTE: Before returning Land Roller into service, all grease must be removed from cylinder shafts to prevent damage to seals.

TROUBLESHOOTING

PROBLEM	CAUSE	CORRECTION
Wings do not fold correctly onto Transport Cross Tube NOTE: Either Roller Tube or Wing Frame can make contact.	A. Land Roller on uneven terrain. B. Cylinder Attach Eye Bolt(s) incorrectly adjusted. C. Debris has built up on contact area between Wing and Center.	Move to level location. Adjust Cylinder Attach Eye Bolt(s). See Pages 3-6 & 3-7. Lower Wings and clean contact area.

SPECIFICATIONS

Working Width	Transport Width	Transport Height**	Transport Length	Machine Weight	Roller Diameter
41'	17'2"	14'2"	26'6"	20,500#	42"
45'	17'2"	15'2"	26'6"	21,000#	42"
50'	16'10"	16'	26'3"	20,000#	36"

** Approximate, varies with machine adjustment.

Tire Size	Rating	Recommended Inflation Pressure
Standard 12.5Lx15	LRF	90 PSI
Optional 340/65R18	148 A8	78 PSI

Hub Size	Rating	Recommended Wheel	Recommended Axle
HD812	6100 LB. 20 MPH Maximum	Nut Torque 240 ft.-lbs.	Nut Torque 45 ft.-lbs., loosen until first slot is aligned with hole in axle, install cotter pin, bend to retain.

SECTION 4 – MAINTENANCE

PROPER BOLT USE

DO NOT use these values if a different torque value or tightening procedure is given for a specific application. Torque values listed are for general use only. Check tightness of fasteners periodically.

BOLT SIZE	WRENCH SIZE	GRADE 5		GRADE 8	
		ft-lbs	N • m	ft-lbs	N • m
1/4"	7/16" or 3/8"	7	9.5	12	17
5/16"	1/2"	15	20	25	34
3/8"	9/16"	30	41	45	61
7/16"	5/8" or 11/16"	45	61	70	95
1/2"	3/4"	70	95	105	142
9/16" wheel bolts	7/8"	140	190	–	–
5/8"	15/16"	170	231	210	285
5/8" wheel nuts	1-1/16"	–	–	240	325
3/4"	1-1/16"* or 1-1/8"	250	339	375	509
7/8"	1-5/16"	350	475	600	814
1"	1-1/2"	450	610	880	1193
1-1/4"	1-7/8"	500	678		
1-1/2"	2-1/4"	570	773		
2"	3-1/8"	1200	1627		

*Nylon Lock Nut

3/26/12 TILLAGE

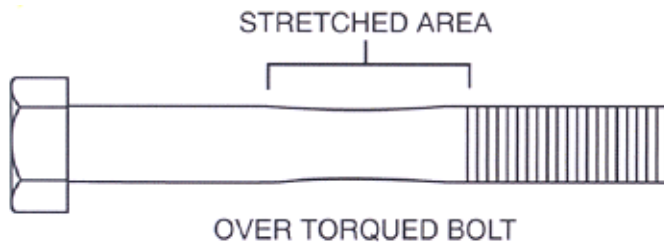

SAE
GRADE 5



SAE
GRADE 8

SECTION 4 – MAINTENANCE

NOTES

OWNER REGISTER INFORMATION, LOCATED AT THE BEGINNING OF THIS MANUAL, MAY BE NEEDED WHEN ORDERING PARTS (SERIAL NUMBER IS LOCATED AT THE FRONT OF HITCH).

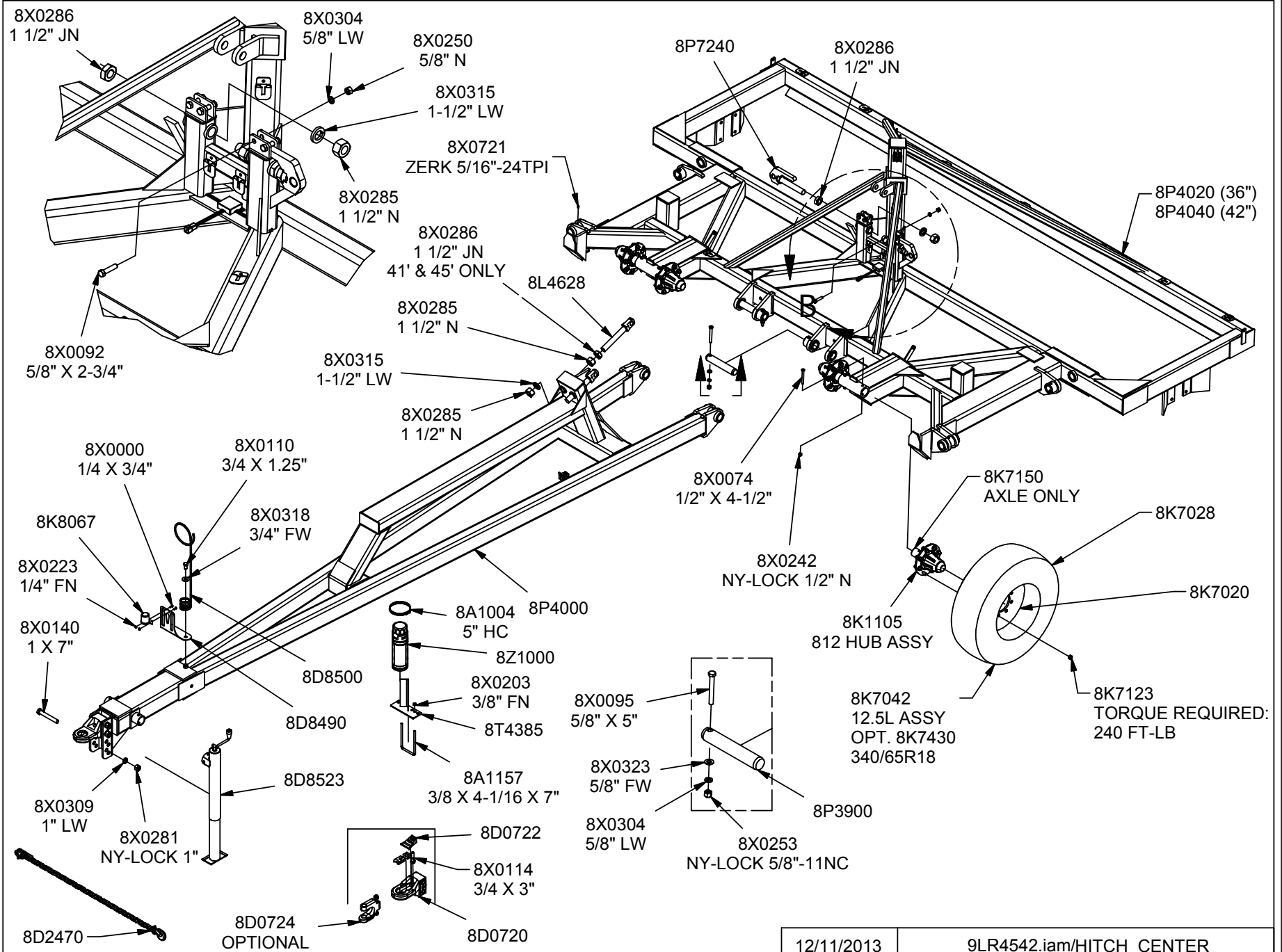

12/11/2013

9LR4542.iam/HITCH_CENTER

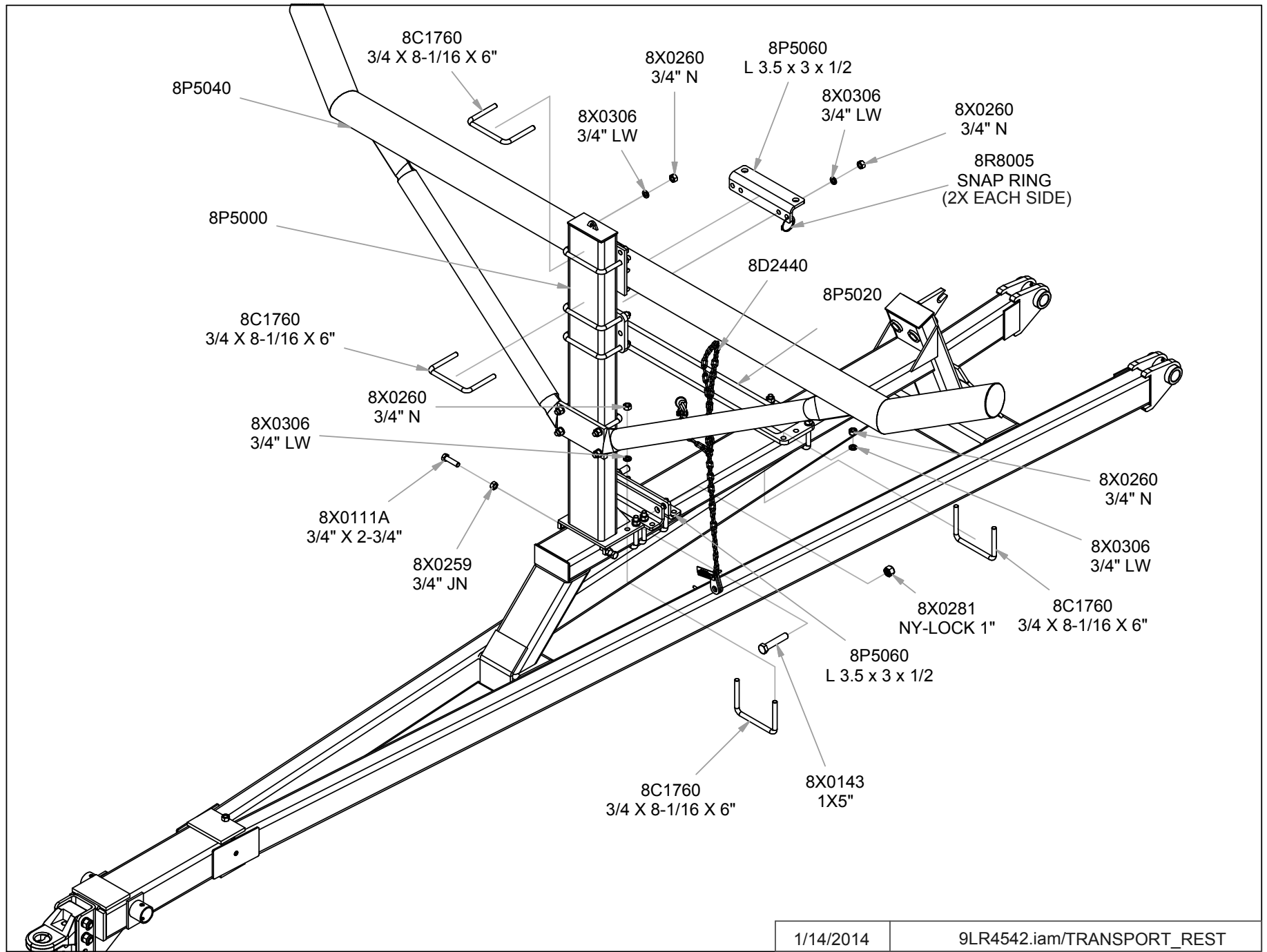

5-4

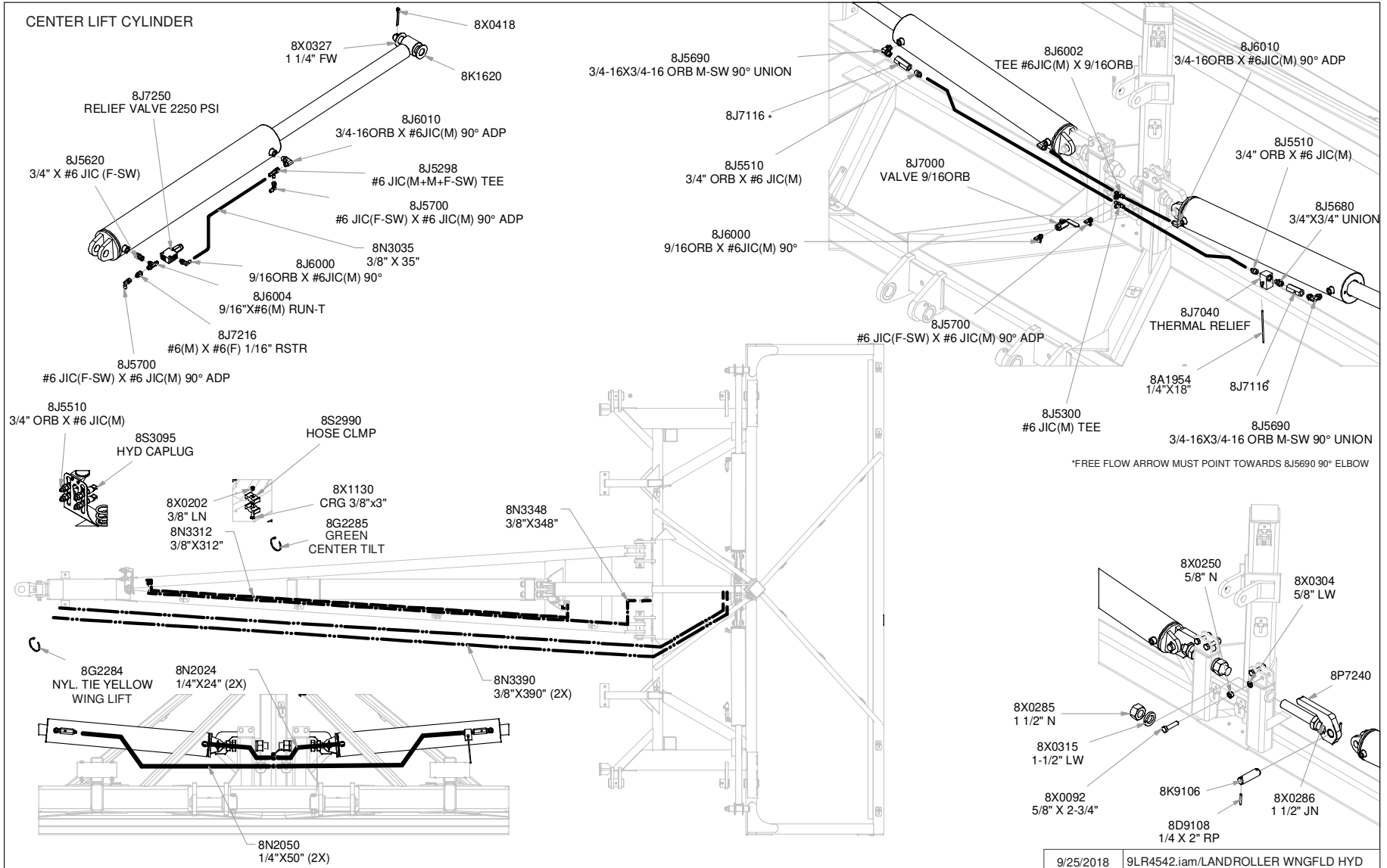

5-5

SECTION 5 - PARTS

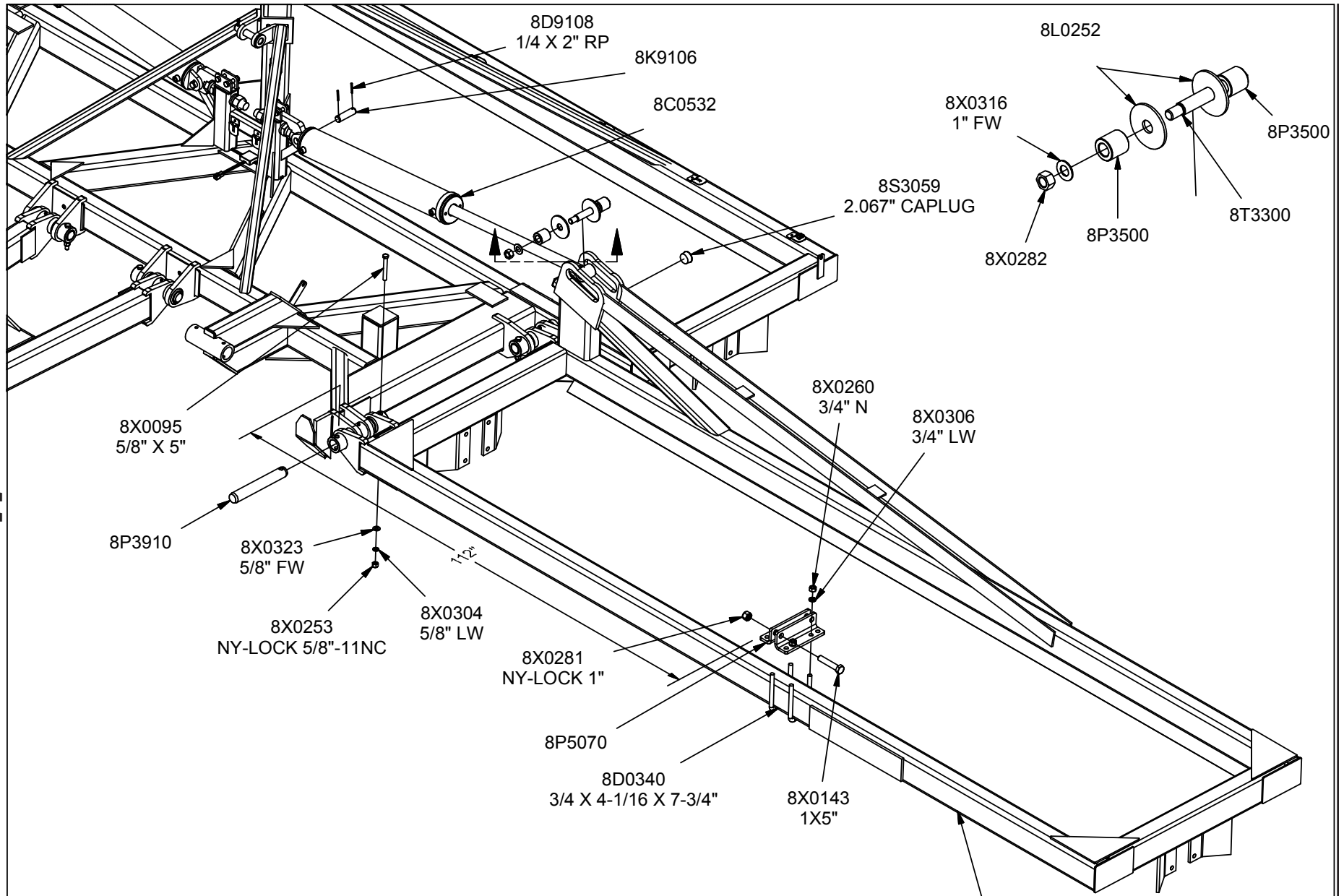

41'	45'	50'
8P4067 - LEFT	8P4070 - LEFT (SHOWN)	8P4075 - LEFT
8P4077 - RIGHT	8P4080 - RIGHT	8P4085 - RIGHT

12/11/2013

9LR4542.iam/WING

5-6

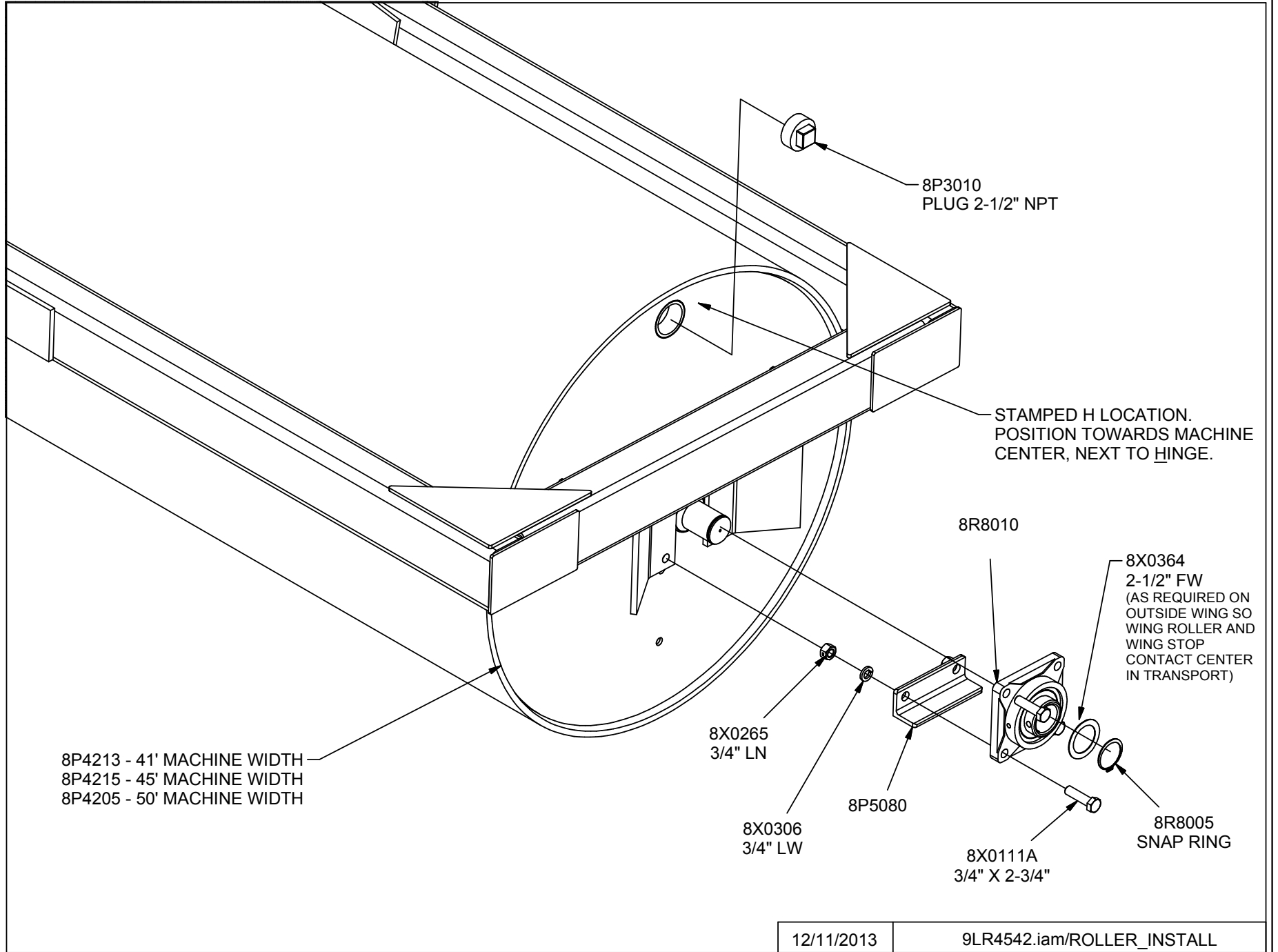

5-7

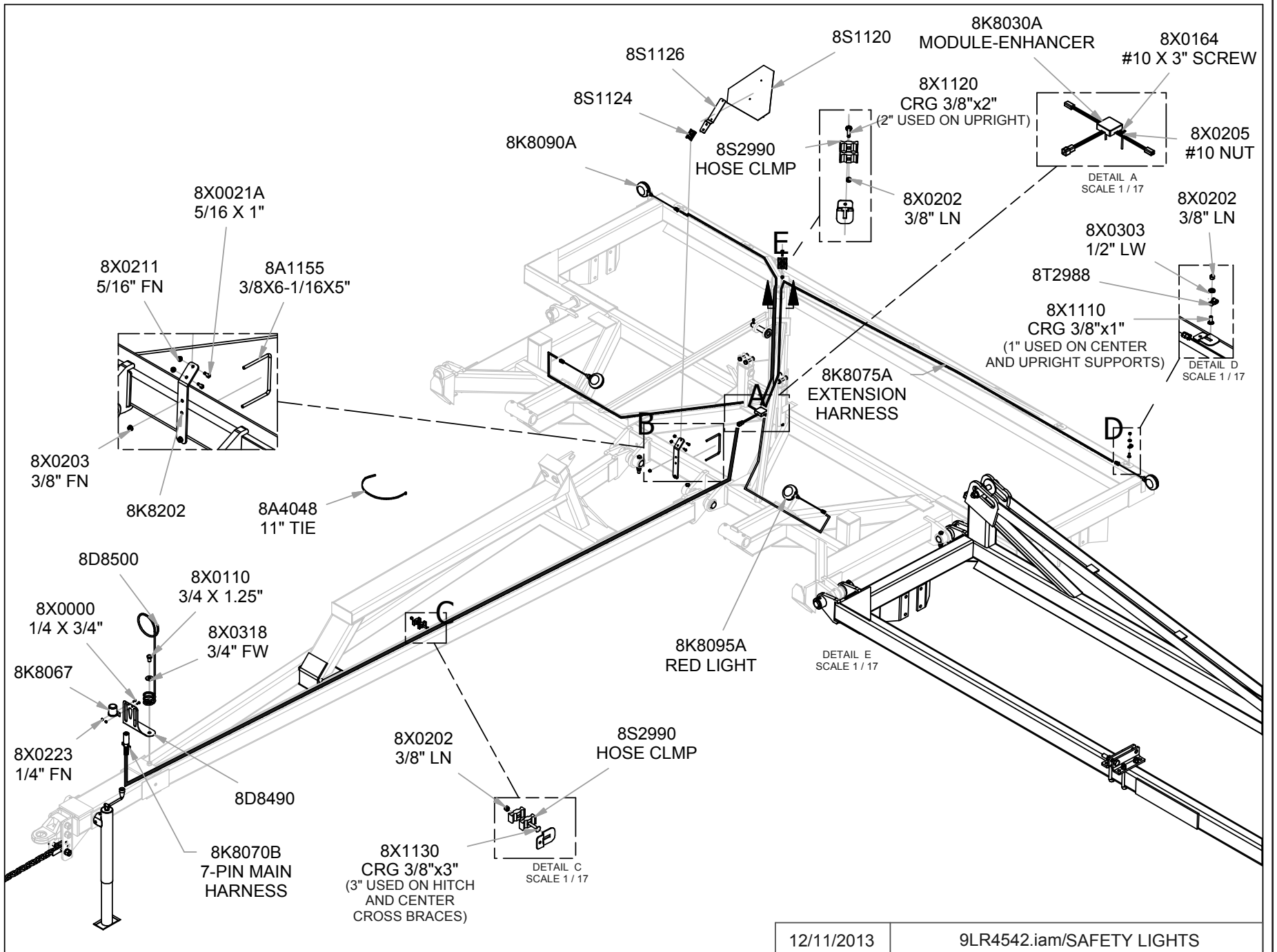

SECTION 5 - PARTS

12/11/2013

9LR4542.iam/SAFETY LIGHTS

HUB AND AXLE COMPONENTS

Assembly Notes:

A. Before towing machine, pack wheel bearings and fill 1/2 of hub cavity with high quality bearing grease.

B. Tighten axle nut to 45 ft.-lbs, loosen nut until first slot is aligned with hole in axle, install cotter pin and bend to retain.

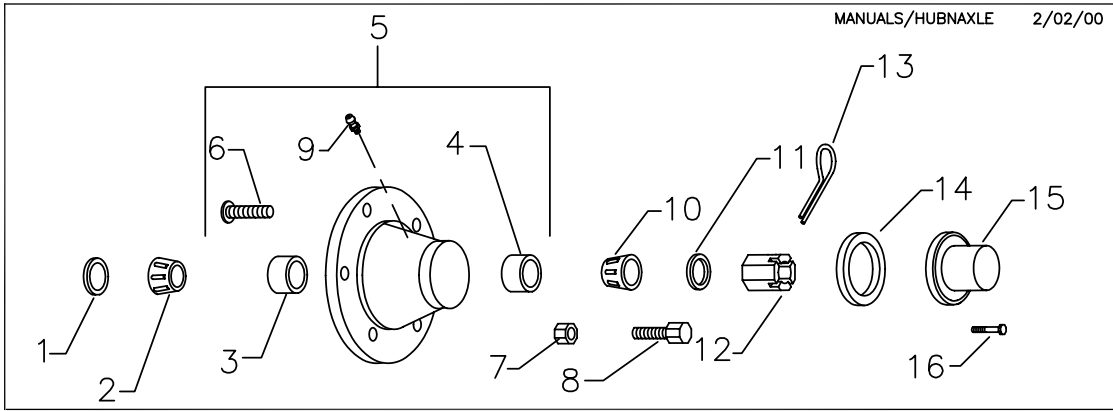

MANUALS/HUBNAXLE 2/02/00

Legend:	SMC	Part Number
	INDUSTRY	Part Number or Size

5-8

HUB	1. SEAL	2. INNER BEARING	3. INNER RACE	4. OUTER RACE	5. HUB ASSY	6. WHEEL STUD	7. WHEEL NUT	8. WHEEL BOLT	9. HUB ZERK	10. OUTER BEARING	11. AXLE WASHER	12. AXLE NUT	13. COTTER PIN	14. HUB CAP GASKET	15. HUB CAP	16. HUB CAP BOLT				
H413	8D5120	8D5117	8D5336	8D5330	M6527850	N/A	N/A	8D5114	8X0708	8D5118	8X0317	8D5112	8X0410	N/A	M6527846	N/A				
	SE11	LM67048	LM67010	LM11910	H413			WB10	1/4-28NF	LM11949	3/4" I.D.	3/4"-16	8/16X1"		DC24					
H511	8D5120	8D5117	8D5336	8D5330	8D5111	N/A	N/A	8D5114	8X0721	8D5118	N/A	8D5112	8X0410	N/A	8D5113	N/A				
	SE11	LM67048	LM67010	LM11910	H511			WB10	5/16-24NF	LM11949		3/4"-16	3/16X1"		DC12					
H517	8D5234	8D5217	8D5332	8D5336	8D5211	8D5215	8D5214	N/A	8X0721	8D5117	8D5219	8D5212	8X0415	N/A	8D5213	N/A				
	8D5236	LM48548	LM48510	LM67010	H517	WB16	1/2-20UNF		5/16-24NF	LM67048	7/8" I.D.	7/8"-14	3/16X1-1/2"		DC13					
H611	8D5221	8D5317	8D5334	8D5336	8D5311	N/A	N/A	8D5114	8X0708	8D5117	8D5319	8D5312	8X0415	N/A	8D5213	N/A				
	SE13	LM29749	LM29710	LM67010	H611			WB10	1/4-28NF	LM67048	1" I.D.	1"-14	3/16x1-1/2"		DC13					
H614	8R6922**	8R6917	8R6925	8D5332	8R6911	N/A	N/A	8R6914	8X0708	8D5217	8D5319	8D5312	8X0415	N/A	8R6913	N/A				
	SE57	LM603049	LM603011	LM48510	H614			WB12	1/4-28NF	LM48548	1" I.D.	1"-14	3/16x1-1/2"		DC15					
LR	HD812	***8K7127 SEAL SE77	8K7117	8K7130	8K7132	8K7111	8K7115-9/16"	8K7116-9/16"	N/A	8X0708	8K7118	8D5319	8D5312	8X0415	N/A	8K7113	N/A			
		8K7128 SLEEVE SE77-1	LM3780	LM3720	LM2720	HD812	8K7122-5/8"	8K7123-5/8"		WB41	WB40	1/4-28NF	LM2790	1" I.D.		1"-14		3/16X1-1/2"	DC17	
							WB46	WB118												

** GBGI (Not Shown), 8R6921 Triple Lip (Shown)
 *** Pre 2006 8K7120(SE17)

SUMMERS MFG. CO., INC.

2/28/17

INSTALLATION AND OPERATION INSTRUCTIONS FOR 8K1800 ACRE METER FOR SUPERROLLER

1. If Roller Shaft is not tapped, weld $\frac{1}{2}$ "-20 UNF nut at center of left pivot shaft of middle roller. Position external taper of nut toward shaft. Insure that threads are not damaged by weld heat or spatter. Allow weld to cool.
 2. Attach Acre Meter with $\frac{1}{2}$ " lock washer. Tighten to 260-390 in-lbs.
- * For accurate logging of acres, it is important that meter is mounted concentrically on roller shaft.
 - * Do not use chemical agents such as thinner, solvents or mineral spirits to clean Acre Meter cover.
 - * Do not attempt to open meter! Attempting to do so can cause injury and may destroy Acre Meter.



CONVERSION FACTOR

NOTE: METER READING MUST BE MULTIPLIED BY CONVERSION FACTOR FOR ACTUAL ACRES.

MACHINE WIDTH	FORMULA
15'	READING x 1.4 = ACRES
21'	READING x 1.9 = ACRES
30'	READING x 2.7 = ACRES
34'	READING x 2.99 = ACRES
41'	READING x 3.6 = ACRES
45'	READING x 4 = ACRES
46'	READING x 4.1 = ACRES
50' (36")	READING x 3.8 = ACRES
53'	READING x 4.7 = ACRES
62'	READING x 5.5 = ACRES
68'	READING x 6.03 = ACRES
84' (36")	READING x 6.5 = ACRES
84' (42")	READING x 7.5 = ACRES
91'	READING x 8.07 = ACRES



<u>Stock Code</u>	<u>Description</u>
8A1155	U-BOLT 3/8 X 6-1/16 X 5" SQ
8A4048	NYLON TIE .18 X 11"
8A4050	NYLON TIE .30 X 8-7/8"
8A4052	NYLON TIE .30 X 15-1/4"
8C0532	HYD CYLINDER 5" X 32" 3500PSI
8C0535	SEAL KIT 5 X32"RAM3000&3500PSI
8C1760	U-BOLT 3/4 X 8 X 6" SQ
8D0340	U-BOLT 3/4 X 4 X 7-3/4" SQ
8D0720	HITCH PIECE CAST CAT.3CTD PNTD
8D0722	PERFECT HTCH BACKSTOP W/HDWE
8D0730	URETHANE CUSHION PERFCTHTCH
8D2440	SAFETY CHAIN 11000# 8MM X 84"
8D2470	SAFETY CHAIN 30400# 7/16" X 5'
8D3212	MALE TIP 3/4"-16 ORB ISO
8D5312	NUT 1"-14NF HEX SLOT GR2 PLN
8D5319	WASHER 1" AXLE
8D8490	PIONEER/ISO TIP HLDR BNT 97-
8D8500	HYD HOSE HOLDER PNTD BLK 91-
8D8521	JACK SPOOL 3 X 2.56- 1-29/32"
8D8523	JACK 8000# DROPLEG 5/8X4.25PIN
8D9108	ROLL PIN 1/4 X 2" YLW ZNC
8G2284	NYLON TIE .187 X 7-1/2" YELLOW
8G2285	NYLON TIE .187 X 7-1/2" GREEN
8J5100	#6 JIC(M) X #6 JIC(M) UNION
8J5300	#6 JIC (MALE) 3X TEE
8J5500	9/16"-18 ORB X #6 JIC(M) STR
8J5510	3/4"-16 ORB X #6 JIC(M) STR
8J5600	9/16"-18 ORB X #6 JIC(F-SW)STR
8J5620	3/4"-16 ORB X #6 JIC(F-SW)STR
8J5680	3/4"-16 ORB X 3/4"-16ORB UNION
8J5690	3/4-16X3/4-16 ORB M-SW90*UNION
8J5700	#6 JIC(F-SW) X #6 JIC(M)90*ADP
8J6000	9/16"-18 ORB X #6 JIC(M)90*ADP
8J6002	9/16"-18ORB X #6 JIC(M)BRNCH T
8J6004	9/16"-18ORB X #6 JIC(M)RUN TEE
8J6010	3/4"-16 ORB X #6 JIC(M)90*ADP
8J6060	3/4"-16ORB X #6JIC(F-SW)90*ADP
8J7000	BALL VALVE HYD 9/16"-18ORB(2X)
8J7040	THERMAL RELIEF MANIFLD 4000PSI
8J7116	3/4"-16 ORB(2X)1WAY 1/16"RESTR
8J7216	#6JIC(M)X6JIC(F)1/16"RSTR GOLD
8J7232	#6JIC(M)X6JIC(F)1/32"RSTR SLVR
8K1105	HUB&AXLE ASSY HD812(2.5"RCVR)
8K1620	PIN 1-1/4 X 6-1/8" 84-
8K7020	WHEEL 15 X 10" 8 BOLT-VLV GRD
8K7028	TIRE 12.5L X 15" LRF TL HWYSRV
8K7111	HUB HD812 W/CUPS&ZRK 8BLT3LIP
8K7113	HUB CAP HD812 DC17
8K7117	BEARING INNER HD812 LM3780
8K7118	BEARING OUTER HD812 LM2790
8K7120	SEAL 2-1/2"ID HD812 SE17 -06
8K7122	STUD WHEEL 5/8-18UNFX2.5"97-
8K7123	NUT 5/8"-18UNF WHEEL BOLT 97-
8K7127	SEAL TRPL LIP EXTRNL HD812 06-
8K7128	SEAL SLEEVE FOR 3X LIP 812 06-
8K7130	RACE INNER HD812 LM3720
8K7132	RACE OUTER HD812 LM2720
8K7150	AXLE HD812 X 11.5" (2.5"DIA.)

<u>Stock Code</u>	<u>Description</u>
8K8030	MODULE AG ENHANCED LIGHT 07-
8K8067	DUST CAP FOR 7PIN CONNECT00-
8K8070B	MAIN HRNSS 7PIN 32' W/BRAKE 09-
8K8075A	EXT HRNSS NONDRAWBR
8K8088	LENS ONLY AMBER GROTE LGHT 00-
8K8090A	LIGHT AMBER
8K8092	LENS ONLY RED GROTE LIGHT 00-
8K8095A	LIGHT RED
8K8202	BRCKT SMV ATTCH BNT 45* LR 05-
8K9106	PIN 1-1/4 X 4-3/8" HARDENED
8L0252	WASHER 1.28"IDX4.5ODX 1/4" ZDI
8L4628	EYEBOLT 1.5"DIA1.25"EYE 1PCYZ
8N2024	1/4X 24"HYD HOSE #6FJX3000PSI
8N2050	1/4X 50"HYD HOSE #6FJX3000PSI
8N3312	3/8X 312"HYD HOSE #6FJX3000PSI
8N3348	3/8X 348"HYD HOSE #6FJX3000PSI
8N3390	3/8X 390"HYD HOSE #6FJX3000PSI
8P3010	PLUG 2-1/2" NPT SQUARE HD STL
8P3500	TUBE 2.25 X 1.27 ID- 2.25" 05-
8P3900	PIN 2 X 11-1/8" HARDENED
8P3910	PIN 2 X 13-1/2" HARDENED
8P4215	ROLLER 42"DIAMETER 15' 05-
8P5000	UPRGHT TRNSPRT RST LNDRLLR 05-
8P5020	BRACE TRNSPRT RST LANDRLLR 05-
8P5040	CROSSTUBE TRNSPRT LNDRLLR 05-
8P5060	ANGLE HTCH LCK 1/2X3X3.5- 14"
8P5070	ANGL WNG LCK 1/2X3X3.5- 10.25"
8P5080	ANGLE BRNG 3/8X2.5X2.5- 7-7/8"
8R8005	SNAP RING .078"FOR 2-1/2"DIA.
8R8010	BEARING 2-1/2"FLNG 4BLT-49/64"
8S1120	SIGN SLOW MOVING VEHICLE(SMV)
8S1124	MOUNTING SOCKET SMV SIGN ZDI
8S1126	MNT SPADE W/HRDWR SMV SIGN
8S2990	HYD HOSE CLAMP-LARGE-NYLON
8S3059	CAPLUG FITS 2.067"ID TUBE96-
8T2988	CLAMP 3/8" WIRING MTL/RUB BCK
8T3300	PIVOT BOLT CHSLTRP&WNLGFT YZ
8X0000	BOLT 1/4-20X3/4"FLTHDGR5 ZDI
8X0000B	BOLT 1/4-20NC X 1" GR5 ZDI
8X0001	BOLT 3/8-16NC X 3/4" GR5 ZDI
8X0002	BOLT 3/8-16NC X 1" GR5 ZDI
8X0003	BOLT 1/4-20NC X 4-1/2" GR5 ZDI
8X0004	BOLT 3/8-16NC X 1-1/4" GR5 ZDI
8X0005	BOLT 1/4-20NC X 3-3/4" GR5 ZDI
8X0006	BOLT 3/8-16NC X 2-1/2" GR5 ZDI
8X0007	BOLT 3/8-16NC X 1-1/2" GR5 ZDI
8X0008	BOLT 3/8-16NC X 2" GR5 ZDI
8X0009	BOLT 1/4-20NC X 2" GR5 ZDI
8X0010	BOLT 1/4-20NC X 1-1/4" GR5 ZDI
8X0013	BOLT 1/4-20NC X 2-1/2" GR5 ZDI
8X0014	BOLT 1/4-20NC X 3" GR5 ZDI
8X0015	BOLT 3/8-16NC X 3-3/4" GR5 ZDI
8X0016	BOLT 3/8-16NC X 3" GR5 ZDI
8X0017	BOLT 3/8-16NC X 5" GR5 ZDI
8X0019	BOLT 3/8-16NC X 4-1/2" GR5 ZDI
8X0020	BOLT 3/8-16X3.5"FULLTHDGR5 ZDI
8X0021	BOLT 5/16-18NC X 3/4" GR5 ZDI
8X0021A	BOLT 5/16-18NC X 1" GR5 ZDI

<u>Stock Code</u>	<u>Description</u>
8X0021B	BOLT 5/16-18NC X 1-1/4" GR5 ZDI
8X0022	SCKT CAP 5/16-18 X 1" GR5ZDI
8X0023	BOLT 5/16-18NC X 2" GR5 ZDI
8X0030	BOLT 5/16-18NC X 5" GR5 ZDI
8X0031	BOLT 7/16-14NC X 1" GR5 ZDI
8X0033	BOLT 7/16X1.25 5/8"THD GR5 ZDI
8X0034	BOLT 7/16X1.75 W/1"THD GR5 ZDI
8X0036	BOLT 7/16-14NC X 2" GR5 ZDI
8X0038	BOLT 7/16-14NC X 2-1/2" GR5 ZDI
8X0041	BOLT 7/16-14NC X 3" GR5 ZDI
8X0044	BOLT 7/16-14NC X 3-1/2" GR5 ZDI
8X0045	BOLT 7/16-14NC X 4-1/2" GR5 ZDI
8X0046	BOLT 7/16-14NC X 7-1/4" GR5 ZDI
8X0047	BOLT 7/16-14NC X 6" GR5 ZDI
8X0061	BOLT 1/2-13NC X 1-1/4" GR5 ZDI
8X0062	BOLT 1/2-13NC X 2" GR5 ZDI
8X0063	BOLT 1/2-13NC X 1-1/2" GR5 ZDI
8X0066	BOLT 1/2-13NC X 1-3/4" GR5 ZDI
8X0067	BOLT 1/2-13NC X 2-1/4" GR5 ZDI
8X0068	BOLT 1/2-13NC X 2-1/2" GR5 ZDI
8X0069	BOLT 1/2-13NC X 3" GR5 ZDI
8X0070	BOLT 1/2-13NC X 3-1/4" GR5 ZDI
8X0072	BOLT 1/2-13NC X 3-3/4" GR5 ZDI
8X0073	BOLT 1/2-13NC X 5" GR5 ZDI
8X0074	BOLT 1/2-13NC X 4-1/2" GR5 ZDI
8X0075	BOLT 1/2-13NC X 6" GR5 ZDI
8X0076	BOLT 1/2-13NC X 5-1/2" GR5 ZDI
8X0077	BOLT 1/2-13NC X 7-1/2" GR5 ZDI
8X0080	BOLT 1/2-13NC X 11" GR5 ZDI
8X0082	BOLT 1/2-13NC X 6-1/2" GR5 ZDI
8X0083	BOLT 1/2-13NC X 8" GR5 ZDI
8X0084	BOLT 1/2-13NC X 9" GR5 ZDI
8X0087	BOLT 5/8-11NC X 1-1/2" GR5 ZDI
8X0090	BOLT 5/8-11NC X 2-1/4" GR5 ZDI
8X0091	BOLT 5/8-11NC X 1-3/4" GR5 ZDI
8X0092	BOLT 5/8-11NC X 2-3/4" GR5 ZDI
8X0093	BOLT 5/8-11NC X 2" GR5 ZDI
8X0095	BOLT 5/8-11NC X 5" GR5 ZDI
8X0096	BOLT 5/8-11NC X 4" GR5 ZDI
8X0098	BOLT 5/8-11X 3.5"FULLTHDGR5ZDI
8X0099	BOLT5/8-11X6.75"W/3.5THDGR5ZDI
8X0101	BOLT 5/8-11NC X 8" GR5 ZDI
8X0102	BOLT 5/8-11NC X 9" GR5 ZDI
8X0106	BOLT 3/4X2.75"W/1.38THD GR8ZDI
8X0107	BOLT 3/4-10NC X 2" GR5 ZDI
8X0110	BOLT 3/4-10NC X 1-1/4" GR5 ZDI
8X0111	BOLT 3/4-10NC X 2-1/2" GR5 ZDI
8X0112	BOLT 3/4-10NC X 2-1/4" GR5 ZDI
8X0113	BOLT 3/4-10NC X 5" GR5 ZDI
8X0114	BOLT 3/4-10NC X 3" GR5 ZDI
8X0115	BOLT 3/4-10NC X 3-1/2" GR5 ZDI
8X0115A	BOLT 3/4NCX 3.5"FULLTHD GR5ZDI
8X0115B	BOLT 3/4-10NC X 3-1/2" GR8 ZDI
8X0116	BOLT 3/4-10NC X 6" GR5 ZDI
8X0117	BOLT 3/4-10NC X 7" GR5 ZDI
8X0118	BOLT 3/4-10NC X 4" GR5 ZDI
8X0118A	BOLT 3/4-10NC X 4-1/4" GR5 ZDI

<u>Stock Code</u>	<u>Description</u>
8X0119	BOLT 3/4-10NC X 7-1/2" GR5 ZDI
8X0120	BOLT 3/4-10NC X 9" GR5 ZDI
8X0121	BOLT 3/4-10NC X 6-1/2" GR5 ZDI
8X0122	BOLT 3/4-10NC X 4-1/2" GR5 ZDI
8X0123	BOLT 3/4-10NC X 5-1/2" GR5 ZDI
8X0125	BOLT 3/4-10NC X 10" GR5 ZDI
8X0130	BOLT 7/8-9NC X 2" GR5 ZDI
8X0132	BOLT 7/8-9NC X 2-1/2" GR5 ZDI
8X0133	BOLT 7/8-9NC X 3" GR5 ZDI
8X0138	BOLT 1-8NC X 5-1/2" GR5 ZDI
8X0139	BOLT 1-8NC X 3" GR5 ZDI
8X0140	BOLT 1-8NCX7" W/1.5"THDGR5ZDI
8X0143	BOLT 1-8NC X 5" GR5 ZDI
8X0164	SCRW TRSS HD SLOT#10X24-3" ZDI
8X0201	NUT 3/8"-16NC HEX GR2 ZDI
8X0202	NUT 3/8"-16NC NY-LOCK GR2 ZDI
8X0203	NUT 3/8"-16NC SER FLANG GR2ZDI
8X0204	NUT 3/8"-16NC HEX GR2 GALV
8X0205	NUT 10-24 HEX ZDI
8X0210	NUT 5/16"-18NC HEX GR2 ZDI
8X0211	NUT 5/16"-18NC SERFLANG GR2ZDI
8X0212	NUT 5/16"-18NC NY-LOCK GR2 ZDI
8X0218	NUT 1/4"-20NC SQ GR2 SS
8X0220	NUT 1/4"-20NC HEX GR2 ZDI
8X0222	NUT 1/4"-20NC NY-LOCK GR2 ZDI
8X0223	NUT 1/4"-20NC SER FLANG GR2ZDI
8X0232	NUT 7/16"-14NC HEX GR2 ZDI
8X0234	NUT 7/16"-14NC NY-LOCK GR2 ZDI
8X0240	NUT 1/2"-13NC HEX GR2 ZDI
8X0242	NUT 1/2"-13NC NY-LOCK GR2 ZDI
8X0244	NUT 1/2"-13NC FLANG TOP LOCK Z
8X0246	NUT 1/2"-13NC SER FLANG GR2 YZ
8X0250	NUT 5/8"-11NC HEX GR2 ZDI
8X0251	NUT 5/8"-11NC JAM GR2 ZDI
8X0253	NUT 5/8"-11NC NY-LOCK GR2 ZDI
8X0256	NUT 5/8"-11NC SER FLANG GR2 YZ
8X0259	NUT 3/4"-10NC JAM GR2 ZDI
8X0260	NUT 3/4"-10NC HEX GR2 ZDI
8X0261	NUT 3/4"-10NC NY-LOCK GR2 ZDI
8X0264	NUT 3/4"-10NC BEVL CNTRLCK ZDI
8X0265	NUT 3/4"-10NC CNTRLCK GR2 ZDI
8X0266	NUT 3/4"-10NC SER FLANG GR2 YZ
8X0268	NUT 7/8"-9NC HEX GR2 ZDI
8X0269	NUT 7/8"-9NC JAM GR2 ZDI
8X0270	NUT 7/8"-9NC CNTRLCK GR2 ZDI
8X0277	NUT 1"-8NC JAM GR2 ZDI
8X0278	NUT 1"-8NC JAM TOPLOCK GR2 ZDI
8X0280	NUT 1"-8NC HEX GR2 ZDI
8X0281	NUT 1"-8NC NY-LOCK GR2 ZDI
8X0282	NUT 1"-14NF TOPLOCK GR2 ZDI
8X0283	NUT 1-1/4"-7NC JAM GR2 ZDI
8X0284	NUT 1-1/4"-7NC HEX GR2 ZDI
8X0285	NUT 1-1/2"-6NC HEX GR2 ZDI
8X0286	NUT 1-1/2"-6NC JAM GR2 ZDI
8X0299	LOCKWASHER 1/4" EXT TOOTH SS
8X0300	LOCKWASHER 5/16" YLW ZNC
8X0301	LOCKWASHER 3/8" YLW ZNC

<u>Stock Code</u>	<u>Description</u>
8X0302	LOCKWASHER 7/16" YLW ZNC
8X0303	LOCKWASHER 1/2" YLW ZNC
8X0304	LOCKWASHER 5/8" YLW ZNC
8X0306	LOCKWASHER 3/4" YLW ZNC
8X0307	LOCKWASHER 7/8" YLW ZNC
8X0308	LOCKWASHER 1/4" YLW ZNC
8X0309	LOCKWASHER 1" YLW ZNC
8X0311	LOCKWASHER 1-1/4" YLW ZNC
8X0315	LOCKWASHER 1-1/2" YLW ZNC
8X0316	WASHER 1" SAE FLAT ZDI
8X0317	WASHER 3/4" SAE FLAT ZDI
8X0318	WASHER 3/4"(13/16"ID)FLAT ZDI
8X0323	WASHER 5/8" SAE FLAT ZDI
8X0327	WASHER 1-1/4" SAE FLAT ZDI
8X0330	WASHER 17/32"ID X 1.25"OD ZDI
8X0331	WASHER 15/32"ID X 1.25"OD ZDI
8X0400	HAIR PIN CLIP 1/8 X 1-15/16"
8X0402	HAIR PIN CLIP 1/8 X 2-9/16"
8X0414	COTTER PIN 1/4 X 2" ZDI
8X0415	COTTER PIN 3/16 X 1-1/2"
8X0418	COTTER PIN 5/16 X 2-1/2" ZDI
8X0510	ROLL PIN 3/16 X 1-1/4" PLN
8X0520	ROLL PIN 3/16 X 2" YZ OR CAD-Y
8X0523	ROLL PIN 5/16 X 2-1/2" PLN

<u>Stock Code</u>	<u>Description</u>
8X0605	SET SCRW SQ HD 7/16-14X 1" ZDI
8X0614	SET SCRW SQ HD 5/8-11 X 2" PLN
8X0632	SET SCRW SCKT 7/16-14X 1.5"PLN
8X0640	SET SCRW SQ HD 1/2-13X 1.5"PLN
8X0665	SET SCRW SQ HD 3/4-10X4.5" ZDI
8X0721	ZERK 5/16"-24 NF STR ZDI
8Z0075	DECAL TRNSPRT LCK WARNING TILL
8Z0086	DECAL ELECTROCUTION DANGER2PT
8Z0087	DECAL"WARNING"PINCH POINT03-
8Z0104	DECAL"WARNING"LNDROLLER HITCH
8Z0106	DECAL"DANGER"LNDRLLR TRNSPRT
8Z0132	DECAL ID SUPERROLLER 05-
8Z0204	DECAL 5.5" SUMMERS
8Z0276	DECAL GENERAL CAUTION 91-
8Z0344	DECAL WING DANGER
8Z0346	DECAL ELECTROCUTION-TILLAGE
8Z0800	REFLECTOR AMBER ADHSVBCK98-
8Z0805	REFLCTR REDORANGE ADHSVBK99-
8Z0810	REFLECTOR RED ADHSV-BACK 98-
8Z1000	MANUAL-PAK 3DIA X 11.75" 09-
8Z1080	OPER MAN 41&45' SUPR ROLLR 05-
8Z2195	DECAL RH8430 ID 41'&45'X 42"HFLR
8Z2197	DECAL RH8330 ID 50'X36"HFLR

History of Summers Manufacturing Co., Inc.

- 1965 – Summers Manufacturing is founded by Harley Summers, who purchases patent rights for Goebel truck and pickup hoists from the Goebel Brothers of Lehr, ND. These hoists, produced in Harley Summers' blacksmith shop the first year, were distributed nationwide by a Cincinnati, Ohio, dealer. With increasing sales, the company soon outgrows the small shop. Summers wins the Herman harrow contract, beginning the company's Herman culti-harrow line. Summers builds a 7,200 square-foot factory in Maddock to meet the demand for truck and pickup hoists, as well as Herman harrows.
- 1969 – Firm incorporates and becomes officially known as Summers Manufacturing Company, Inc.
- 1970 – Summers purchases rights to manufacture/market the Herman Harrow.
- 1973 – Company builds new 20,000 square-foot plant and offices in Maddock, adding a 20,000 square-foot assembly plant in the fall of 1975 (completed in January 1976), bringing total square footage of Maddock factories to 47,000.
- 1977 – Summers introduces the Agri-sprayer, used in conjunction with the Herman culti-harrow to incorporate herbicides and liquid fertilizer.
- 1980 – Company purchases manufacturing and distributing rights to Crown rockpickers from Crown Manufacturers of Regina, Saskatchewan. This forces another expansion project – a 26,000 square foot factory on a 24 acre site in Devils Lake, ND Industrial Park.
- 1981 – Company establishes a branch facility in Regina, Saskatchewan.
- 1982 – Devils Lake plant begins operations in January, manufacturing supersprayers and rockpickers. The Maddock factory begins producing the Superweeder, a combination cultivator and harrow.
- 1983 – Summers buys manufacturing and distributing rights to the Fargo Field Sprayer line from Mid America Steel (formerly Fargo Foundry), Fargo. This field sprayer line is manufactured at the Devils Lake plant. Harley Summers is selected North Dakota's small-businessman of the year by the Small Business Administration.
- 1984 – Herman Diamond Disk, a disk harrow made in a diamond shape to reduce blade breakage from rocks, comes off the assembly line.
- 1985 – Summers signs a contract with Melroe Company of Bismarck to obtain exclusive manufacturing rights to the Melroe harrow line.
- 1989 – Summers purchases TorMaster Company of Hordean, Manitoba, giving the company a line of rolling packer equipment, comprised of harrow packers and hydraulic fold coil packers.
- 1992 – A new engineering office/parts department is added to the Devils Lake factory.
- 1993 – Company adds two new products: a pickup-mounted sprayer with booms of 80 and 90 feet, and the Summers Superharrow, an extra-heavy-duty residue-management tool designed for the minimum and no-till farmer.
- 1994 – a 50 by 125 foot addition to the Maddock factory is completed. Construction begins on a 24,576 square-foot addition to the Devils Lake factory, which enables the company to increase production of truck-mounted and pull-type supersprayers and rockpickers.
- 1996 – 1500 square foot office area added to the Maddock plant. Company introduces Chisel Plow with floating hitch and 700# trip assembly.
- 1997 – 16,800 square foot warehouse in Maddock purchased from local business.
- 1999 - Company introduces the Ultimate suspended boom trailer sprayer with hydraulic folding booms. Additional sizes added to the Chisel Plow line, now ranging from 28' to 54'.
- 2000 - Company introduces the Supercoulter, the innovative solution for excessive field residue management on no-till, minimum-till, and conventional-till farming operations.
- 2001 - Cold storage building completed at Devils Lake. Company extends boom lengths up to 110 feet on the Ultimate Supersprayer.
- 2002 - Company adds a warehouse and service man in Aberdeen, SD.
- 2003 - Company introduces the Ultimate NT Supersprayer featuring a bolt on axle for easier adjustment, and a new family of tanks that feature a drainable sump and a common width dimension.
- 2004 - A 124 ft. x 310 ft. addition is added onto the current Devils Lake plant.
- 2005 - The Summers Superroller is added to the "Field Tested Tough" product line. Additional sizes of 56', 58' and 60' are added to the Superchisel line. Ultimate-Ultra NT Supersprayer introduced featuring 120' & 133' booms.
- 2006 - The Summers Coulter-Chisel, Rolling Choppers and 30' Superroller were included in product line.
- 2007 - 62' & 84' 5 Section Landrollers and a 20' Coulter-Chisel were introduced.
- 2008 - Disk-Chisels, ranging from 16' to 40' widths, are added to product line.
- 2009 – M105 and M108 Mounted Harrows added to selection of Mounted Attachments. SuperHarrow 2650, 50' SuperCoulter, Hydraulic Fold Rolling Chopper and 36" diameter Landrollers introduced.
- 2010 – Rolling Basket and 47' Diamond Disk added to product line. A 124 ft. x 310 ft. addition to Devils Lake factory built for a state of the art paint system.
- 2011 – Additional Supercoulter sizes were added along with larger tires for tillage implements. Ultimate and Ultra Supersprayers received an additional tank size of 1650 gallons. Front Caster Wheel option was made available for chisel implements.
- 2012 – 41', 46' & 53' Trail Type Landroller added to product line. Additional Superchisel sizes of 16' & 20' were added.
- 2013 – DT9530 added to product line. Internal Scraper in Rolling Baskets introduced. Finishing Coulter Gang becomes standard on the Diamond Disk and 2510 DT. Corporate offices opened at Devils Lake plant. New building and location for the Aberdeen warehouse.
- 2014 – Introduced the VRT2530 (Variable Rate Tillage).
- 2015 – Introduced the VT Flex Applicator and Spray Fill Xpress.

Summers distributes on a wholesale level to dealers and distributors throughout markets in North Dakota, South Dakota, Minnesota, Montana, Iowa, Washington, Idaho, Oregon, Utah, Colorado, Kansas, Nebraska, Oklahoma, Texas, Manitoba, Saskatchewan, Alberta, British Columbia, Kazakhstan, Russia and Australia, making it an international company.

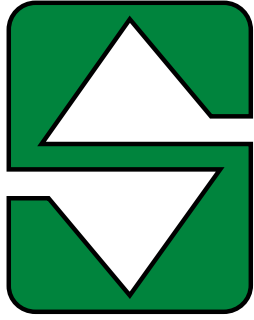

SUMMERS[®]

... Field Tested TOUGH!



Tillage



Rock Picker



Land Rollers/Packers



Cultivators/Harrows



Mounted Attachments



Sprayers



1-800-732-4347 • www.summersmfg.com