

# Farm King

## OPERATOR AND PARTS MANUAL

### Snowblower

Model 96"

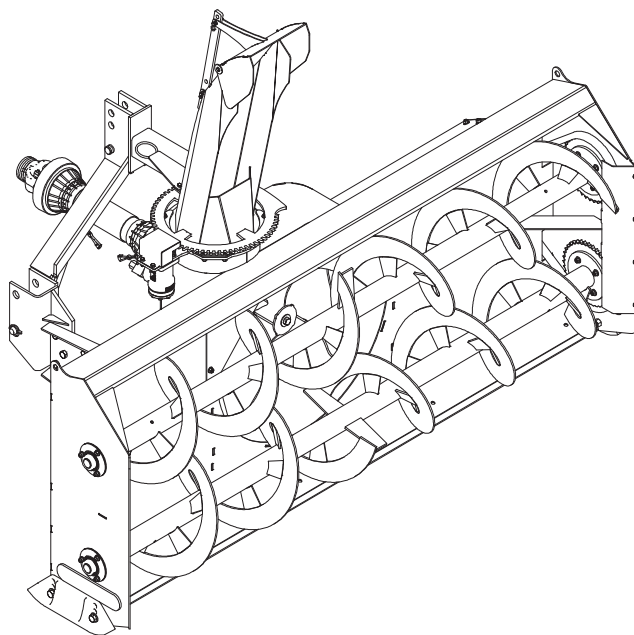



# Table Of Contents

**Manufacturer’s Statement:** For technical reasons, Buhler Industries Inc. reserves the right to modify machinery design and specifications provided herein without any preliminary notice. Information provided herein is of descriptive nature. Performance quality may depend on soil fertility, applied agricultural techniques, weather conditions, and other factors.

Warranty Registration Form.....1

Introduction.....3

    Owner’s Information.....5

    Equipment Identification.....6

Safety.....9

    Safety Instructions.....11

    Fire Prevention.....14

    Safety Signs (Decals).....16

    Equipment Decals And Signs Farm King.....17

    Equipment Decals And Signs Allied.....18

    Safety Sign-Off Form.....19

Assembly.....21

    Preparing For Assembly.....23

    PTO Shield.....24

    Cutting Edge (Option).....24

    Hitch.....24

    Discharge Spout.....25

    Hydraulic Spout Rotator.....26

Operation.....27

    Pre - Operation Checklist.....29

    Entering The Operator’s Position.....29

    Leaving The Operator’s Position.....29

    Tractor Requirements.....29

    Connecting The Snowblower To Tractor.....30

    Connecting The PTO Driveline.....32

    Connecting Hydraulic Hoses.....36

    Adjusting Skid Shoe Height.....37

    Theory Of Operation.....38

    Transporting.....39

<b>Maintenance</b> .....	41
Service Schedule Chart.....	43
Lubrication.....	44
Chains And Fasteners.....	46
Safety Sign (Decal) Installation.....	47
Storage And Return To Service.....	47
<b>Parts Identification</b> .....	49
Main Components.....	51
Discharge Spout.....	54
Hydraulic Spout Rotator - F1545.....	56
Cutting Edge (Option) - X3897.....	57
Oil Bath Gearbox - BU50505.....	58
PTO Shaft - F1696.....	60
PTO Shaft Long - F1695.....	61
Hydraulic Spout Deflector Cylinder 1.75" x 5" (Option).....	62
Additional Components.....	63
<b>Specifications And Shipping Kit Numbers</b> .....	65
Specifications.....	67
Shipping Kit And Bundle Numbers Farm King.....	67
Shipping Kit And Bundle Numbers Allied.....	68
Hardware Torque Values.....	69
<b>Warranty</b> .....	71
Farm King Base Limited Warranty.....	73

## Warranty Registration Form

**This form must be filled out by the dealer and signed by both the dealer and the customer at the time of delivery.**

Customer Name:	
Customer Address:	
City:	Prov / State:
Postal / Zip Code:	Phone:

Dealer Name:	
Dealer Address:	
City:	Prov / State:
Postal / Zip Code:	Phone:

Snowblower Model:	Serial Number:	Delivery Date:
-------------------	----------------	----------------

I have thoroughly instructed the buyer on the above described equipment which review included the Operator and Parts Manual content, equipment care, adjustments, safe operation and applicable warranty policy.

**Dealer Inspection Report**

- Bearings Turn Freely
- Chain Tension Checked
- Skid Shoes Properly Adjusted
- All Fasteners Are Tight
- Lubricate Machine
- Hydraulic Hoses And Fittings Tight (If Applicable)

**Safety**

- Safety Chain On Hitch
- All Decals Installed
- Guards And Shields Installed And Secure
- Review Operating And Safety Instructions
- Check For Hydraulic Leaks (If Applicable)

Date:	Dealer Rep. Signature:
-------	------------------------

The above equipment and Operator And Parts Manual have been received by me and I have been thoroughly instructed as to care, adjustments, safe operation and applicable warranty policy.

Date:	Customer / Owner Signature:
-------	-----------------------------

**Remove this Warranty Registration Form from the Operator And Parts Manual. Make two copies of the form. Send original Warranty Registration Form to Farm King. Give one copy to the customer and the dealer will keep one copy.**

# Farm King



## Introduction

This Operator And Parts Manual was written to give the owner / operator instructions on the safe operation, maintenance and part identification of the Farm King equipment. READ AND UNDERSTAND THIS OPERATOR AND PARTS MANUAL BEFORE OPERATING YOUR FARM KING EQUIPMENT. If you have any questions, see your Farm King dealer. This manual may illustrate options and accessories not installed on your Farm King equipment.

Owner's Information.....	5
Serial Number Location.....	5
Manual Storage.....	5
Equipment Identification.....	6
Component Location - Front View.....	6
Component Location - Top View.....	7

# Farm King





## Owner's Information

Thank you for your decision to purchase a Farm King Snowblower. To ensure maximum performance of your equipment, it is mandatory that you thoroughly study the Operator And Parts Manual and follow the recommendations. Proper operation and maintenance are essential to maximize equipment life and prevent personal injury.

Operate and maintain this equipment in a safe manner and in accordance with all applicable local, state, and federal codes, regulations and / or laws. Follow all on-product labeling and instructions.

Make sure that all personnel have read this Operator And Parts Manual and thoroughly understand safe and correct operating, installation and maintenance procedures.

Farm King is continually working to improve its products. Farm King reserves the right to make any improvements or changes as deemed practical and possible without incurring any responsibility or obligation to make any changes or additions to equipment sold previously.

Although great care has been taken to ensure the accuracy of this publication, Farm King makes no warranty or guarantee of any kind, written or expressed, implied or otherwise with regard to the information contained within this manual. Farm King assumes no responsibility for any errors that may appear in this manual and shall not be liable under any circumstances for incidental, consequential or punitive damages in connection with, or arising from the use of this manual.

Keep this manual available for frequent reference. All new operators or owners must review the manual before using the equipment and annually thereafter. Contact your Farm King Dealer if you need assistance, information, or additional copies of the manual.

Visit our website at [www.farm-king.com](http://www.farm-king.com) for a complete list of dealers in your area.

The directions left, right, front and rear, as mentioned throughout this manual, are as viewed by the operator sitting in the tractor seat while towing the implement.

## Serial Number Location

Please enter the model and serial number in the space provided for easy reference.

**Figure 1**

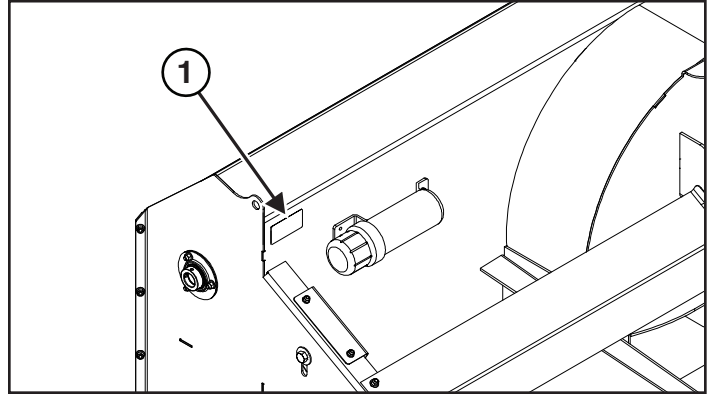

**Model Number:** \_\_\_\_\_

**Serial Number:** \_\_\_\_\_

The serial number plate (Item 1) [Figure 1] is located on the top corner of the main frame.

Always use your serial number when requesting information or when ordering parts.

## Manual Storage

**Figure 2**

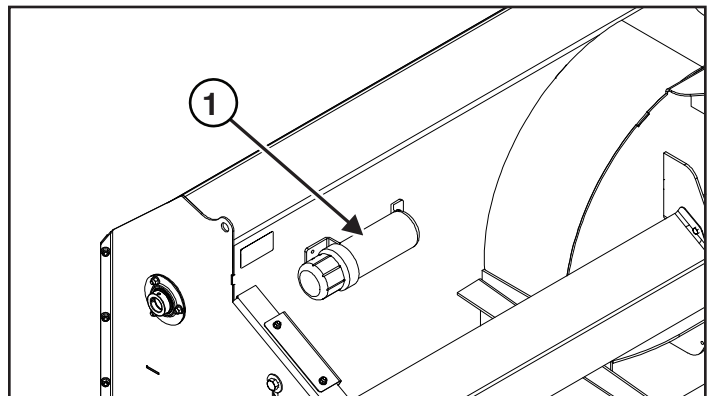

The operator and parts manual and other documents can be stored in the canister (Item 1) [Figure 2].

## Equipment Identification

### Component Location - Front View

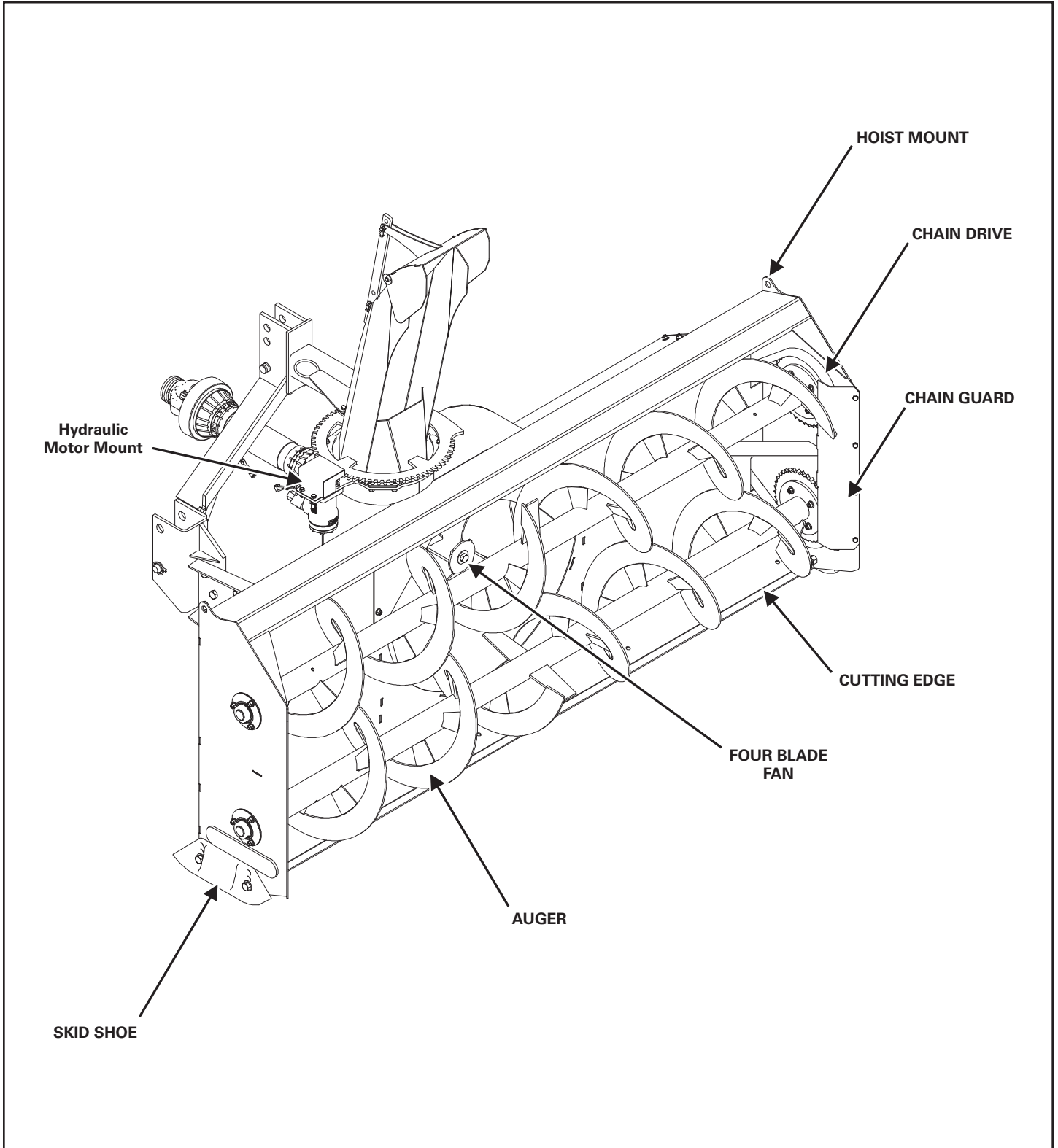

**Component Location - Top View**

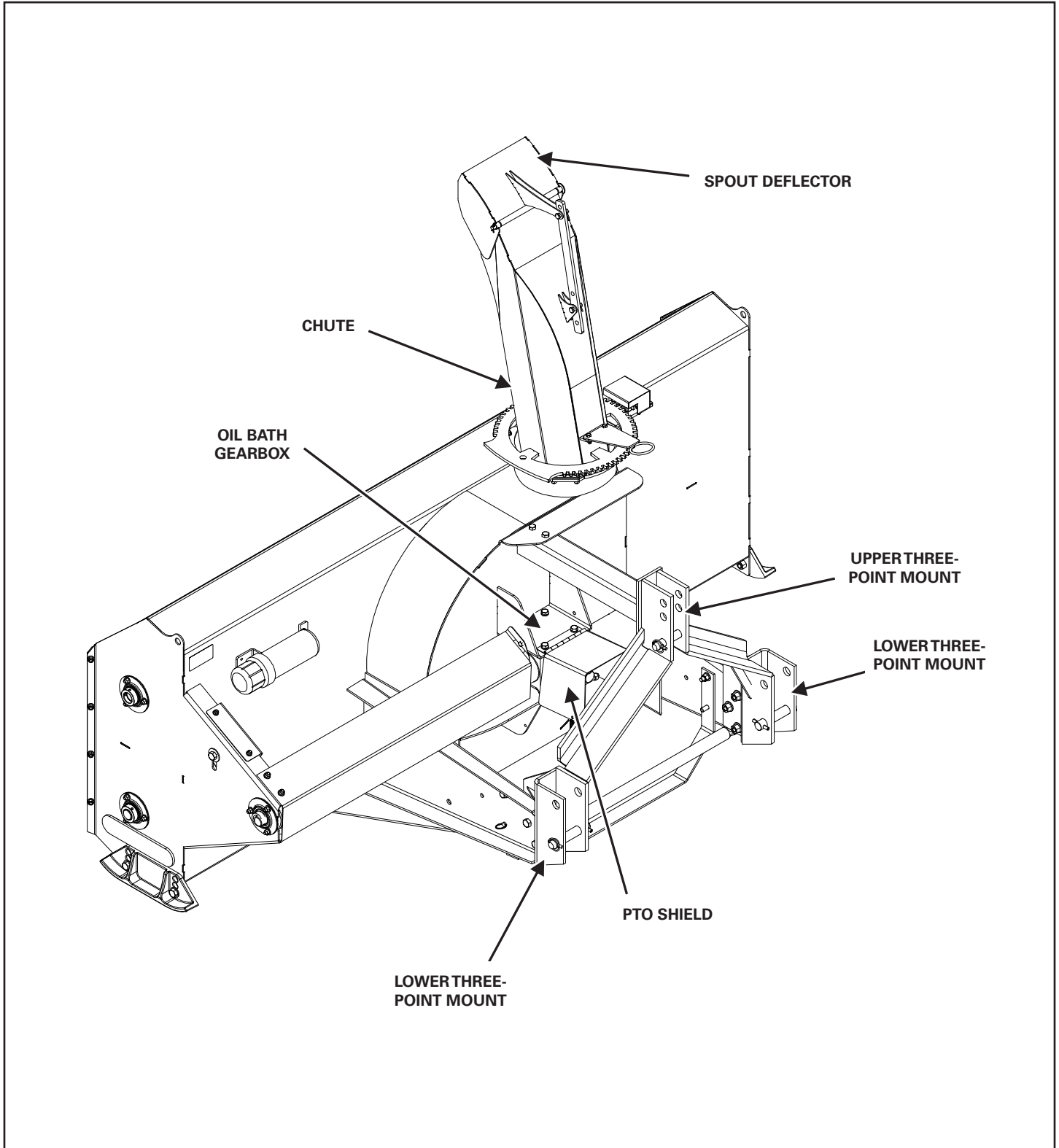

# Farm King



# Safety

- Safety Instructions.....11
  - Safe Operation is The Operator’s Responsibility.....11
  - Safe Operation Needs A Qualified Operator.....11
  - Use Safety Rules.....12
  - Safety Rules For Power Take-Off (PTO) Driven Equipment.....12
  - Machine Requirements And Capabilities.....13
  - Transport Safety.....13
- Fire Prevention.....14
  - Maintenance.....14
  - Operation.....14
  - Starting.....14
  - Electrical.....14
  - Hydraulic System.....14
  - Fueling.....14
  - Welding And Grinding.....15
  - Fire Extinguishers.....15
- Safety Signs (Decals).....16
- Equipment Decals And Signs Farm King.....17
- Equipment Decals And Signs Allied.....18
- Safety Sign-Off Form.....19

# Farm King







## Safety Instructions

### Safe Operation is The Operator's Responsibility

	<b>Safety Alert Symbol</b>
<p>This symbol with a warning statement means: "Warning, be alert! Your safety is involved!" Carefully read the message that follows.</p>	

	<b>CAUTION</b>
<p>The signal word CAUTION on the machine and in the manuals indicates a potentially hazardous situation which, if not avoided, may result in minor or moderate injury. It may also be used to alert against unsafe practices.</p>	

	<b>DANGER</b>
<p>The signal word DANGER on the machine and in the manuals indicates a hazardous situation which, if not avoided, will result in death or serious injury.</p>	

	<b>WARNING</b>
<p>The signal word WARNING on the machine and in the manuals indicates a potentially hazardous situation which, if not avoided, could result in death or serious injury.</p>	

	<b>IMPORTANT</b>
<p>This notice identifies procedures which must be followed to avoid damage to the machine.</p>	

### Safe Operation Needs A Qualified Operator

	<b>WARNING</b>
<p><b>Operators must have instructions before operating the machine. Untrained operators can cause injury or death.</b></p>	

For an operator to be qualified, he or she must not use drugs or alcohol which impair alertness or coordination while working. An operator who is taking prescription drugs must get medical advice to determine if he or she can safely operate a machine and the equipment.

Understand the written instructions, rules and regulations:

- The written instructions from Farm King include the Warranty Registration, Dealer Inspection Report, Operator And Parts Manual and machine signs (decals).
- Check the rules and regulations at your location. The rules may include an employer's work safety requirements. Regulations may apply to local driving requirements or use of a Slow Moving Vehicle (SMV) emblem. Regulations may identify a hazard such as a utility line.

Have Training with Actual Operation:

- Operator training must consist of a demonstration and verbal instruction. This training is given by the machine owner prior to operation.
- The new operator must start in an area without bystanders and use all the controls until he or she can operate the machine safely under all conditions of the work area. Always fasten seat belt before operating.

Know the Work Conditions:

- Clear working area of all bystanders, especially small children and all obstacles that might be hooked or snagged, causing injury or damage.
- Know the location of any overhead or underground power lines. Call local utilities and have all underground power lines marked prior to operation.
- Wear tight fitting clothing. Always wear safety glasses when doing maintenance or service.

## Use Safety Rules

- Read and follow instructions in this manual and the tractor's Operators Manual before operating.
- Under no circumstances should young children be allowed to work with this equipment.
- This equipment is dangerous to children and persons unfamiliar with its operation.
- Check for overhead and / or underground lines before operating equipment (if applicable).
- In addition to the design and configuration of equipment, hazard control and accident prevention are dependent upon the awareness, concern, prudence and proper training of personnel involved in the operation, transport, maintenance and storage of equipment.
- Check that the equipment is securely fastened to the tractor / towing vehicle.
- Make sure all the machine controls are in the NEUTRAL position before starting the machine.
- Operate the equipment only from the operator's position.
- Operate the equipment according to the Operator And Parts Manual.
- When learning to operate the equipment, do it at a slow rate in an area clear of bystanders, especially small children.
- DO NOT permit personnel to be in the work area when operating the equipment.
- The equipment must be used ONLY on approved tractors / transport vehicles.
- DO NOT modify the equipment in any way. Unauthorized modification may impair the function and / or safety and could affect the life of the equipment.
- Stop tractor engine, place all controls in neutral, set park brake, remove ignition key and wait for all moving parts to stop before servicing, adjusting, repairing, unplugging or filling.
- DO NOT make any adjustments or repairs on the equipment while the machine is running.
- Keep shields and guards in place. Replace if damaged.
- Keep hands, feet, hair and clothing away from all moving parts.

## Safety Rules For Power Take-Off (PTO) Driven Equipment

- Keep PTO shields and all guards in place. Replace damaged or missing shields and guards before operating.
- Follow warnings and instructions on machine signs (decals). Replace damaged or missing decals.
- Do not wear loose or bulky clothing around the PTO or other moving parts.
- Keep bystanders away from PTO driven equipment, and never allow children near machines.
- Read and understand the manuals for the PTO driven equipment and be aware of safe operating procedures and hazards that may not be readily apparent.
- Never operate over 540 rpm.
- Always walk around equipment to avoid coming near a turning PTO driveline. Stepping over, leaning across or crawling under a turning PTO driveline can cause entanglement.
- Position the machine and equipment hitch correctly to prevent driveline stress and separation.
- Use caution when turning. Turning too sharp can cause driveline damage.
- Use caution when raising PTO driven equipment.
- Excessive driveline angle can cause driveline damage. Use stops if needed.
- Maximum working PTO angle is 25 degrees.



## Machine Requirements And Capabilities

- Fasten seat belt securely. If equipped with a foldable Roll-Over Protective Structure (ROPS), only fasten seat belt when ROPS is up and locked. DO NOT wear seat belt if ROPS is down.
- Stop the machine and engage the parking brake. Install blocks in front of and behind the rear tires of the machine. Install blocks underneath and support the equipment securely before working under raised equipment.
- Keep bystanders clear of moving parts and the work area. Keep children away.
- Use increased caution on slopes and near banks and ditches to prevent overturn.
- Make certain that the Slow Moving Vehicle (SMV) emblem is installed so that it is visible and legible. When transporting the equipment, use the flashing warning lights (if equipped) and follow all local regulations.
- Operate this equipment with a machine equipped with an approved Roll-Over Protective Structure (ROPS). Always wear seat belt when the ROPS is up. Serious injury or death could result from falling off the machine.
- Before leaving the operator's position:
  1. Always park on a flat level surface.
  2. Place all controls in neutral.
  3. Engage the parking brake.
  4. Stop engine.
  5. Wait for all moving parts to stop.
- Carry passengers only in designated seating areas. Never allow riders on the machine or equipment. Falling off can result in serious injury or death.
- Start the equipment only when properly seated in the operator's seat. Starting a machine in gear can result in serious injury or death.
- Operate the machine and equipment from the operator's position only.
- The parking brake must be engaged before leaving the operator's seat. Roll-away can occur because the transmission may not prevent machine movement.

## Transport Safety

- Do not exceed 20 mph (32 kph). Reduce speed on rough roads and surfaces.
- Comply with state and local laws governing highway safety and movement of machinery on public roads.
- The use of flashing amber lights is acceptable in most localities. However, some localities prohibit their use.
- Local laws should be checked for all highway lighting and marking requirements.
- Always yield to oncoming traffic in all situations and move to the side of the road so any following traffic may pass.
- Always enter curves or drive up or down hills at a low speed and at a gradual steering angle.
- Never allow riders on either tractor or equipment.
- Keep tractor / towing vehicle in a lower gear at all times when traveling down steep grades.
- Maintain proper brake settings at all times (if equipped).

## Fire Prevention



### Maintenance

- The machine and some equipment have components that are at high temperatures under normal operating conditions. The primary source of high temperatures is the engine and exhaust system. The electrical system, if damaged or incorrectly maintained, can be a source of arcs or sparks.
- Flammable debris (leaves, straw, etc.) must be removed regularly. If flammable debris is allowed to accumulate, it can cause a fire hazard. Clean often to avoid this accumulation. Flammable debris in the engine compartment is a potential fire hazard. The operator's area, engine compartment and engine cooling system must be inspected every day and cleaned if necessary to prevent fire hazards and overheating.
- All fuels, most lubricants and some coolant mixtures are flammable. Flammable fluids that are leaking or spilled onto hot surfaces or onto electrical components can cause a fire.

### Operation

- The Farm King machine must be in good operating condition before use.
- Check all of the items listed on the service schedule under the 8 hour column before operation. (See Maintenance section)
- Do not use the machine where exhaust, arcs, sparks or hot components can contact flammable material, explosive dust or gases.

### Starting

- Do not use ether or starting fluids on any engine that has glow plugs. These starting aids can cause explosion and injure you or bystanders.
- Use the procedure in the tractor's operator's manual for connecting the battery and for jump starting.

### Electrical



- Check all electrical wiring and connections for damage. Keep the battery terminals clean and tight. Repair or replace any damaged part or wires that are loose or frayed.
- Battery gas can explode and cause serious injury. Do not jump start or charge a frozen or damaged battery. Keep any open flames or sparks away from batteries. Do not smoke in battery charging area.

### Hydraulic System

- Check hydraulic tubes, hoses and fittings for damage and leakage. Never use open flame or bare skin to check for leaks. Hydraulic tubes and hoses must be properly routed and have adequate support and secure clamps. Tighten or replace any parts that show leakage.
- Always clean fluid spills. Do not use gasoline or diesel fuel for cleaning parts. Use commercial nonflammable solvents.

### Fueling



- Stop the engine and let it cool before adding fuel. No smoking! Do not refuel a machine near open flames or sparks. Fill the fuel tank outdoors.

## Welding And Grinding

- Always clean the machine and equipment, disconnect the battery, and disconnect the wiring from the machine controls before welding. Cover rubber hoses, battery and all other flammable parts. Keep a fire extinguisher near the machine when welding.
- Have good ventilation when grinding or welding painted parts. Wear dust mask when grinding painted parts. Toxic dust or gas can be produced.
- Dust generated from repairing nonmetallic parts such as hoods, fenders or covers can be flammable or explosive. Repair such components in a well ventilated area away from open flames or sparks.

## Fire Extinguishers



- Know where fire extinguishers and first aid kits are located and how to use them. Inspect the fire extinguisher and service the fire extinguisher regularly. Obey the recommendations on the instructions plate.

## Safety Signs (Decals)

Follow the instructions on all the signs (decals) that are on the equipment. Replace any damaged signs (decals) and be sure they are in the correct locations. Equipment signs are available from your Farm King equipment dealer.

**Figure 3**

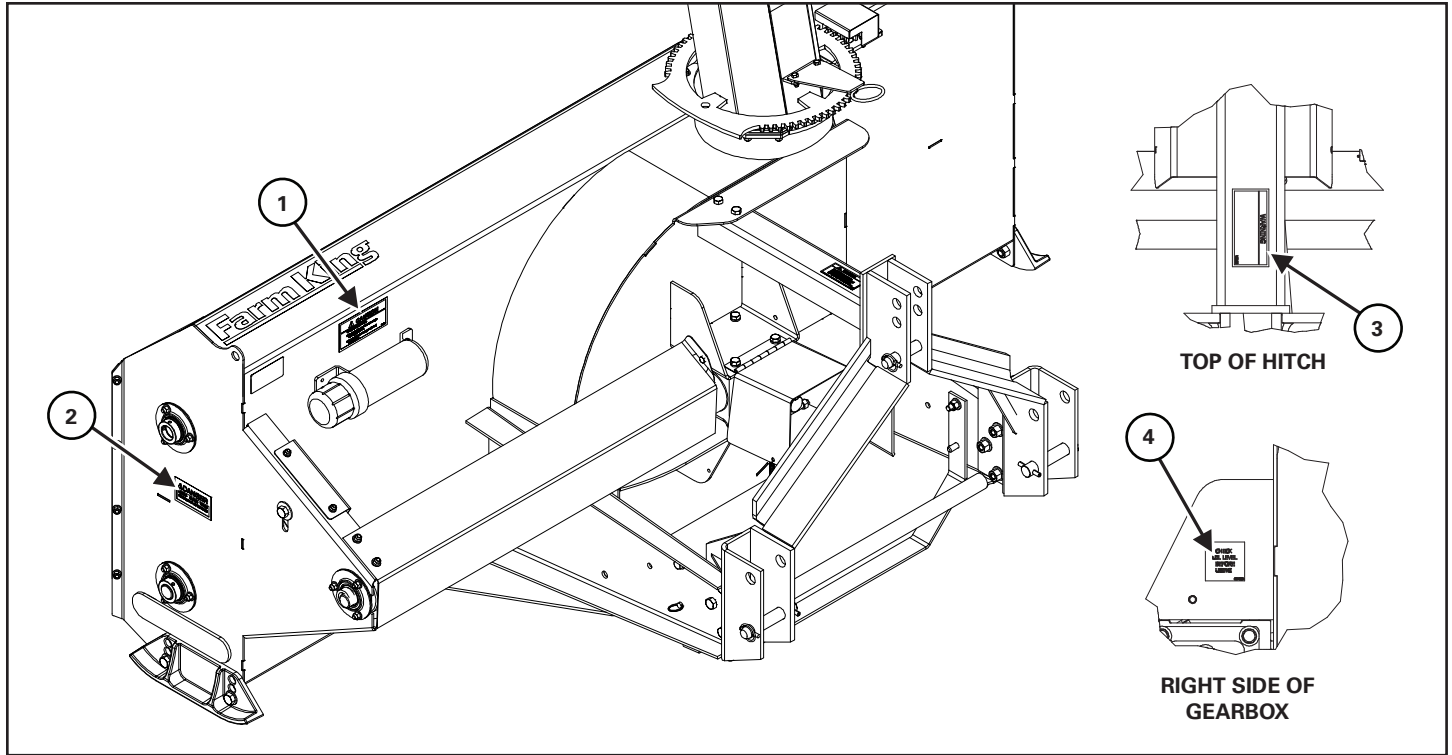

963206 (Item 1) [Figure 3]

 <b>CAUTION</b>
<ol style="list-style-type: none"> <li>1. Keep all shields in place.</li> <li>2. Disengage all power when servicing or unplugging machine.</li> <li>3. Keep hands and clothing away from all moving parts.</li> </ol>
963206

102893 (Item 2) [Figure 3]

 <b>DANGER</b>
<b>STAND CLEAR WHEN MACHINE IN OPERATION</b>
102893

108431 (Item 3) [Figure 3]

 <b>WARNING</b>
<b>CHECK PTO SHAFT LENGTH BEFORE RAISING OR LOWERING IMPLEMENT. SHAFT MUST NOT BOTTOM OR SEPERATE (SEE MANUAL)</b>
108431

967388 (Item 4) [Figure 3]

<b>CHECK OIL LEVEL BEFORE USING</b>
967388

## Equipment Decals And Signs Farm King

Check and replace any worn, torn, missing, or hard to read decals on your equipment.

Figure 4

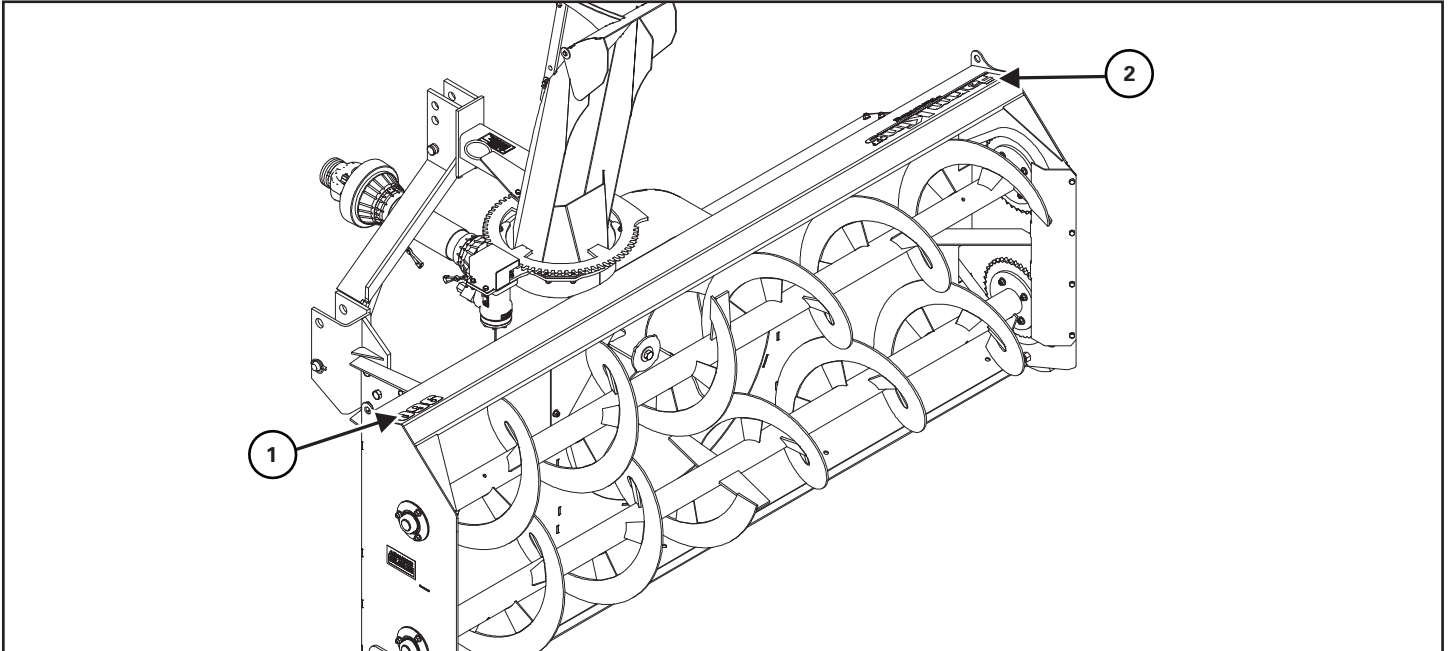

910623 (Item 1) [Figure 4]

960

817585 (Propeller Model Not Shown)



910626 (Item 2) [Figure 4]

**Farm King**

## Equipment Decals And Signs Allied

Check and replace any worn, torn, missing, or hard to read decals on your equipment.

**Figure 5**

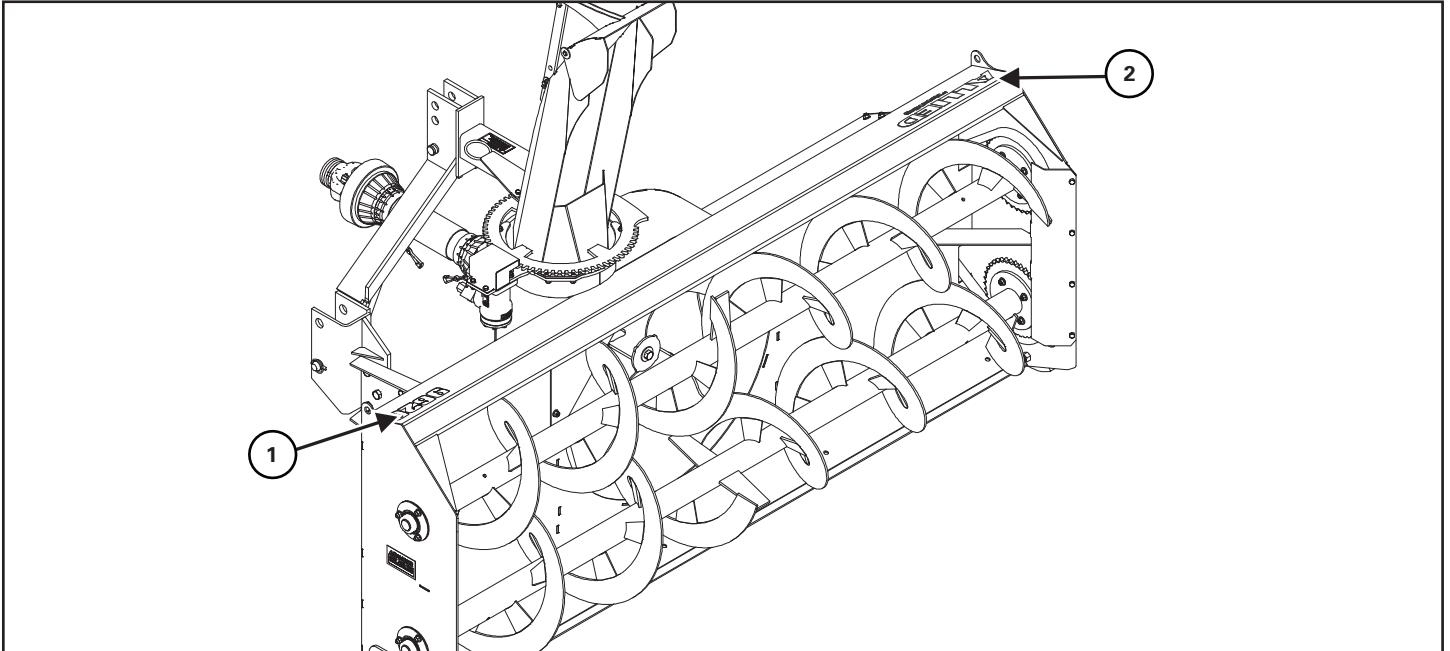

910825 (Item 1) [Figure 5]



817585 (Propeller Model Not Shown)



815035 (Item 2) [Figure 5]



## Safety Sign-Off Form

	WARNING
<p><b>Instructions are necessary before operating or servicing equipment. Read and understand the Operator And Parts Manual and safety signs (decals) on equipment. Follow warnings and instructions in the manuals when making repairs, adjustments or servicing. Check for correct function after adjustments, repairs or service. Untrained operators and failure to follow instructions can cause injury or death.</b></p>	

Farm King follows the general Safety Standards specified by the American Society of Agricultural and Biological Engineers (ASABE) and the Occupational Safety and Health Administration (OSHA). Anyone who will be operating and / or maintaining the snowblower must read and clearly understand ALL Safety, Operating and Maintenance information presented in this manual.

Annually review this information before the season start-up and make these periodic reviews of SAFETY and OPERATION a standard practice for all of your equipment. An untrained operator is unqualified to operate this machine.

The following sign-off sheet is provided for your record and to show that all personnel who will be working with the equipment have read and understand the information in this Operator And Parts Manual and have been instructed in the operation of the equipment.

SIGN-OFF SHEET		
Date	Employee's Signature	Employer's Signature



# Farm King





# Assembly

Preparing For Assembly.....	23
PTO Shield.....	24
Cutting Edge (Option).....	24
Hitch.....	24
Discharge Spout.....	25
Hydraulic Spout Deflector (Option).....	25
Hydraulic Spout Rotator.....	26

# Farm King



## Preparing For Assembly

	<b>IMPORTANT</b>
<p>Snowblowers are shipped without some components installed due to transport restrictions.</p> <ul style="list-style-type: none"> <li>• Using the packing list, locate and count the individual components and verify that you have received the correct number of each component.</li> <li>• Check all the components for damage. If any components are damaged or missing, contact your Farm King dealer.</li> </ul>	

	<b>WARNING</b>
	
<p><b>AVOID INJURY OR DEATH</b></p> <p>Before moving the tractor, look in all directions and make sure no bystanders, especially small children are in the work area. Do not allow anyone between the tractor and the equipment when backing up to the equipment for connecting.</p>	

Move the tractor, snowblower and components to an area large enough for assembly.

	<b>WARNING</b>
<p><b>AVOID INJURY OR DEATH</b></p> <p>Before you leave the operator's position:</p> <ul style="list-style-type: none"> <li>• Always park on a flat level surface.</li> <li>• Place all controls in NEUTRAL.</li> <li>• Engage the park brake.</li> <li>• Stop the engine and remove the key.</li> <li>• Wait for all moving parts to stop.</li> </ul>	

Park the tractor / equipment on a flat level surface.

Place all controls in neutral, engage the park brake, stop the engine and wait for all moving parts to stop. Leave the operator's position.

	<b>WARNING</b>
<p><b>AVOID INJURY OR DEATH</b></p> <p>Wear safety glasses to prevent eye injury when any of the following conditions exist:</p> <ul style="list-style-type: none"> <li>• When fluids are under pressure.</li> <li>• Flying debris or loose material is present.</li> <li>• Engine is running.</li> <li>• Tools are being used.</li> </ul>	

## PTO Shield

**Figure 6**

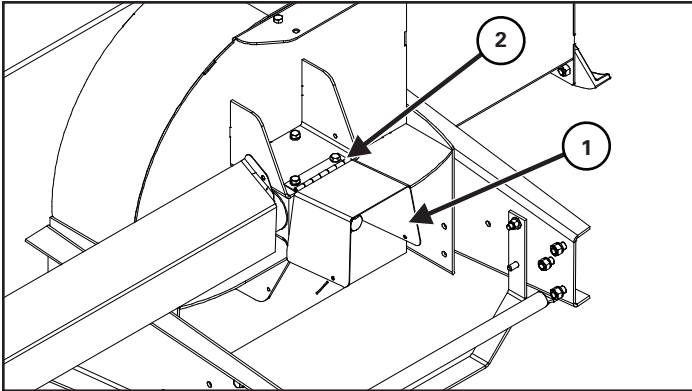

Install the PTO shield (Item 1) to the top of the gearbox assembly using two 1/2" hex bolts and two lock washers (Item 2) **[Figure 6]**.

Hook the spring through the hole in the shield and through the hole in the gusset plate underneath the gearbox to hold the shield down.

## Cutting Edge (Option)

**Figure 7**

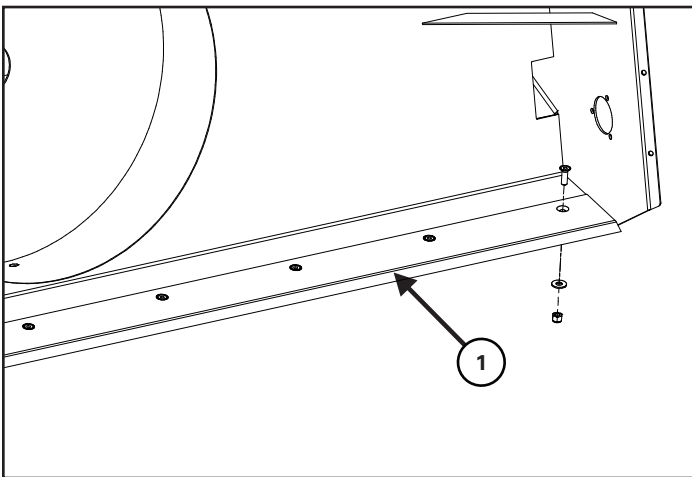

Install the cutting edge (Item 1) **[Figure 7]** to the bottom of the snowblower intake frame. Attach using eight 1/2" x 1-1/2" bolts, eight 1/2" washers, and eight 1/2" lock nuts.

## Hitch

**Figure 8**

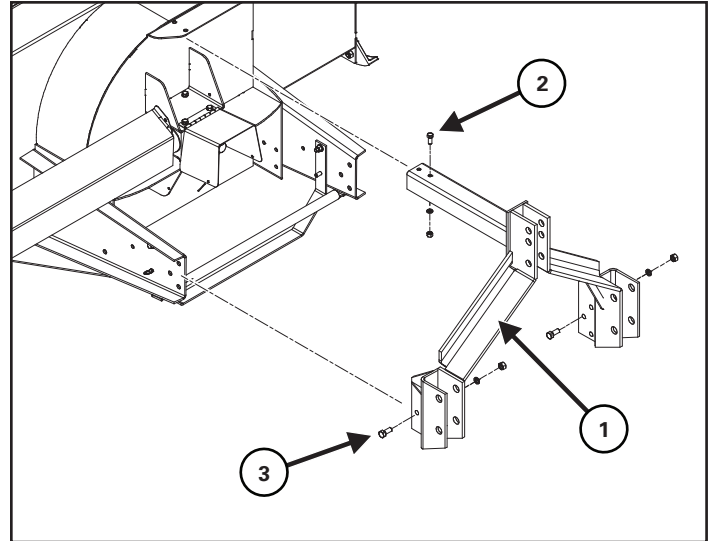

Align the hitch weldment (Item 1) **[Figure 8]** to the brackets on the main frame.

Attach each lower mount with three 5/8" lock nuts, three 5/8" flat washers, and three 5/8" x 1-1/2" bolts (Item 3) **[Figure 8]**.

Attach the top mount with two 1/2" lock nuts, two 1/2" flat washers, and two 1/2" x 1-1/4" (Item 2) **[Figure 8]**.

Install one 1" top link pin at the top three-point mount and two 1-1/8" link pins at the bottom three-point mounts.

## Discharge Spout

Figure 9

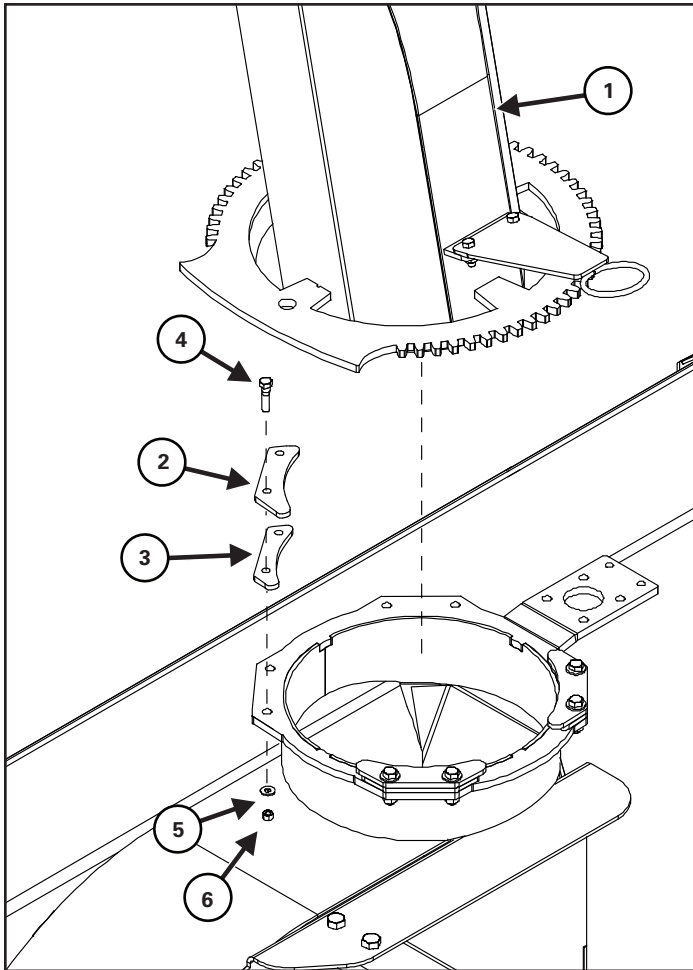

Align the discharge spout (Item 1) [Figure 9] on the main frame mount. Position the smooth portion of the spout ring opposite the motor mount.

Place the four spacers (Item 3) and spout clamps (Item 2) [Figure 9] around the spout ring on the mounts.

Lubricate the spout ring and spout clamps using multipurpose lithium based grease.

Attach the spacers and clamps to the mounts using eight 3/8" x 1-1/2" bolts (Item 4), eight 5/16" flat washers (Item 5), and eight 3/8" lock nuts (Item 6) [Figure 9].

Figure 10

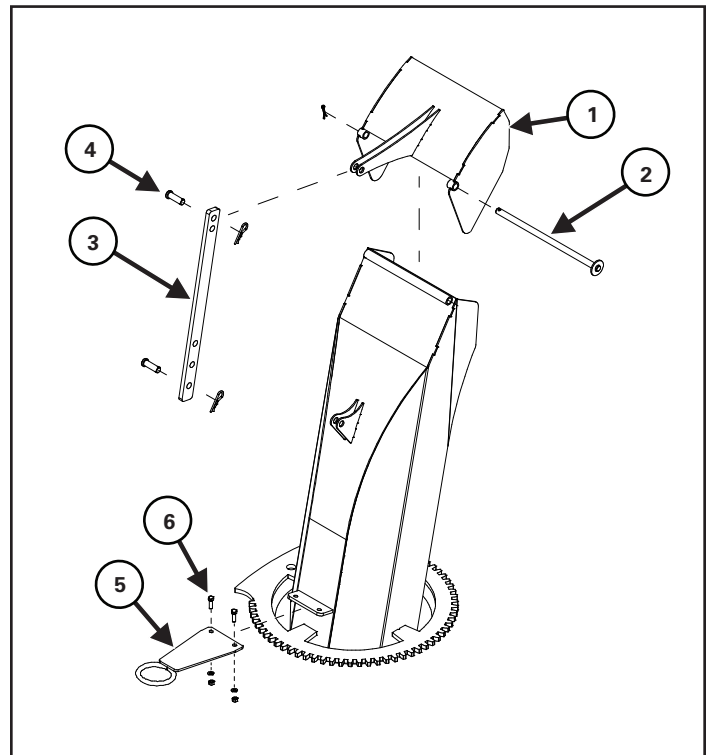

Attach the deflector (Item 1) to the discharge spout using one hinge rod (Item 2) [Figure 10] and one 1/8" x 1" cotter pin.

Align the deflector adjustment rod (Item 3) on the spout mounts. Attach using two 1/2" x 1-1/2" clevis pins (Item 4) [Figure 10] and clips.

Align the hose holder (Item 5) with the bottom spout mounts. Attach using two 5/16" x 1" bolts (Item 6) [Figure 10], 5/16" lock nuts, and 5/16" flat washers.

### Hydraulic Spout Deflector (Option)

Replace the spout deflector adjustment rod (Item 3) [Figure 10] on the discharge spout with a 5" hydraulic cylinder.

Attach using clevis pins and hair pin clips. Connect the two return / supply hydraulic hoses and route through the hydraulic hose holder (Item 5) [Figure 10] and to the hitch.

## Hydraulic Spout Rotator

Figure 11

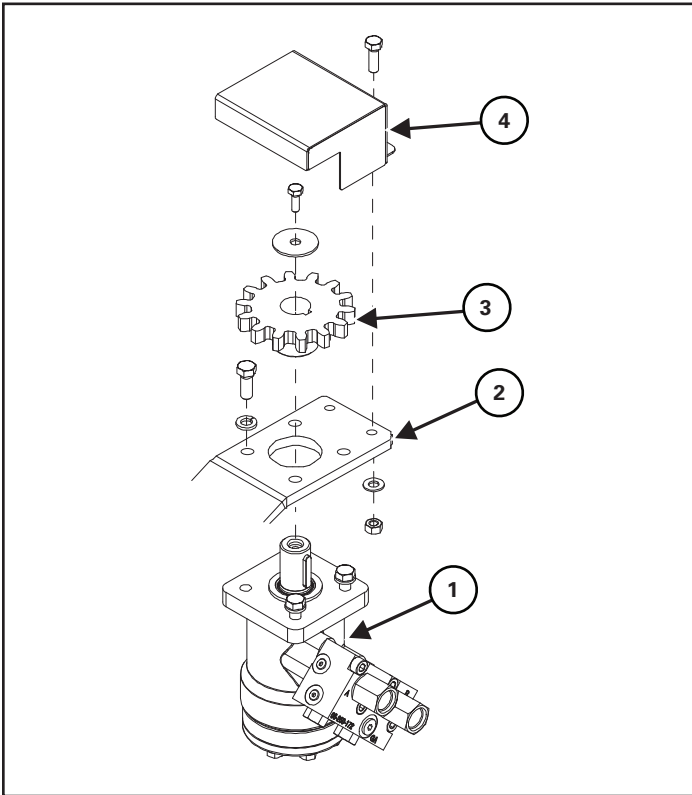

Align the motor assembly (Item 1) with the main frame mount (Item 2) **[Figure 11]** and attach with four 3/8" bolts and four 3/8" lock washers.

Ensure that the manifold and hydraulic hose fittings are facing the snowblower hitch.

Slide the gear (Item 3) **[Figure 11]** onto the motor drive line with the gear hub facing downwards. Align the gear with the toothed spout ring. Attach the gear using one 1/4" x 3/4" bolt and 1-1/2" OD x 5/16" ID washer.

The discharge spout opening should face forward. The non-toothed smooth portion of the gear spout ring should face left, the side opposite of the motor mount.

Attach the gear guard cover (Item 4) **[Figure 11]** over the motor using two 5/16" x 1" bolts, two 5/16" washers, and two 5/16" lock nuts.

Attach the hydraulic hoses to manifold. Route the hoses through the hose holder and to the snowblower hitch.

# Operation

Pre - Operation Checklist.....	29
Entering The Operator's Position.....	29
Leaving The Operator's Position.....	29
Tractor Requirements.....	29
Connecting The Snowblower To Tractor.....	30
Connecting The PTO Driveline.....	32
PTO Driveline Length Check.....	33
PTO Driveline Bottoming Out Check.....	33
Reducing The PTO Driveline Length.....	34
PTO Driveline Engagement Check.....	35
Connecting Hydraulic Hoses.....	36
Disconnecting Hydraulic Hoses.....	36
Adjusting Skid Shoe Height.....	37
Theory Of Operation.....	38
Transporting.....	39



# Farm King







## Pre - Operation Checklist

Before operating the snowblower for the first time and each time thereafter, check the following items:

1. Lubricate the equipment per the schedule outline in the Maintenance Section.
2. Check the snowblower hitch for damaged, loose or missing parts. Repair as needed before operation.

**Note:** Do not operate with leaks.

3. Make sure that all guards and shields are in place, secured and functioning as designed.
4. Check condition of all hydraulic components for leaks. Repair as required.

	<b>WARNING</b>
	
<p><b>HIGH PRESSURE FLUID HAZARD</b></p> <p>Leaking fluids under pressure can enter the skin and cause serious injury or death. Immediate medical attention is required. Wear goggles. Use cardboard to check for leaks.</p>	

**Note:** Do not operate with hydraulic leaks.

6. Check that all electrical connections are tight.
7. Check the augers. Remove any twine, wire or other material that has become entangled.

## Entering The Operator's Position

Enter the operator's position, start the engine, and release the parking brake.

	<b>IMPORTANT</b>
<p>Follow the instructions in your tractor's operation manual for the correct procedure.</p>	

## Leaving The Operator's Position

Always perform the following steps when leaving the operator's position:

	<b>WARNING</b>
<p><b>AVOID INJURY OR DEATH</b></p> <p>Before you leave the operator's position:</p> <ul style="list-style-type: none"> <li>• Always park on a flat level surface.</li> <li>• Place all controls in NEUTRAL.</li> <li>• Engage the park brake.</li> <li>• Stop the engine and remove the key.</li> <li>• Wait for all moving parts to stop.</li> </ul>	

## Tractor Requirements

The tractor must satisfy the following requirements, depending on model.

96":

- 90 - 125 HP w/ Cat. II / III hitch

## Connecting The Snowblower To Tractor

Always inspect the tractor's three-point hitch and snowblower's three-point mounts before connecting. See the tractor's owner's manual.

Move the tractor drawbar into the storage position or remove (if necessary) to prevent interference with snowblower operation. (See the tractor's operator's manual for the correct procedure.)

**Figure 12**

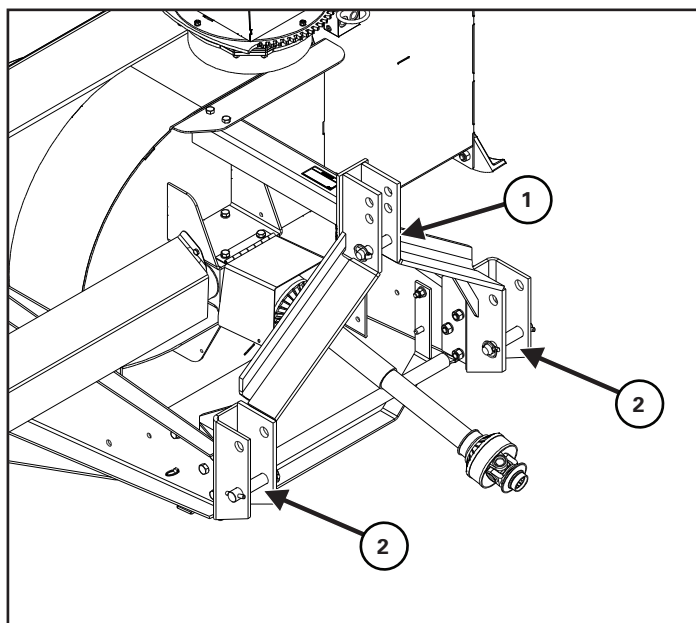

Remove the top implement mounting pin (Item 1) [Figure 12] and lynch pin.

Remove the lynch pins from the left and right lower mounts (Item 2) [Figure 12].

Enter the operator's position (See "Entering The Operator's Position" in Operation section).

Move the tractor into position in front of the snowblower.

Move the tractor backwards, aligning the tractor's three-point hitch and snowblower three-point mounts.

Leave the operator's position (See "Leaving The Operator's Position" in Operation section).

	WARNING
	
<p><b>AVOID INJURY OR DEATH</b></p> <p><b>Before moving the tractor, look in all directions and make sure no bystanders, especially small children are in the work area.</b></p> <p><b>Do not allow anyone between the tractor and the equipment when backing up to the equipment for connecting.</b></p>	

Install the left and right lower three-point mounts of the tractor to the snowblower left and right lower mounting pins.

Reinstall the lynch pins.

**Note:** Always use implement mounting pins of adequate size and strength and a retaining pin with a locking device.

Lower the top link of the three-point hitch until it aligns with the implement upper mount.

Reinstall the mounting pin and lynch pin.

**Note:** It may be necessary to lengthen or shorten the top link to align it with the implement mounting hole. (See the tractor's operator's manual for the correct procedure.)

The implement can be leveled front to back by adjusting the top link. (See the tractor's operator's manual for the correct procedure.)

Adjust the lower link sway chains or blocks on the tractor to restrict side movement of the snowblower when operating.



## IMPORTANT

Excessive backward tilt may cause the "U" joints to flutter resulting in PTO shear bolt failure.



## WARNING



### AVOID INJURY OR DEATH

Keep fingers and hands out of pinch points when connecting and disconnecting equipment.

### Connecting The PTO Driveline

Stop the engine and leave the operator’s position (See “Leaving The Operator’s Position” in Operator’s section).

	<b>WARNING</b>
<b>AVOID INJURY OR DEATH</b>	
<b>Warnings on the machine and in the manuals are for your safety. Failure to obey warnings can cause serious injury or death.</b>	

**Note:** Clean and grease tractor’s PTO shaft and PTO driveline coupling each time driveline is connected.

	<b>IMPORTANT</b>
<b>Improper hitch installation can cause PTO driveline damage.</b>	
<ul style="list-style-type: none"> <li>Do not modify the three point hitch.</li> <li>Make sure the PTO driveline is of adequate length and that u-joints are in the correct phase.</li> </ul>	

Remove the PTO driveline from the storage position (if applicable).

Figure 13

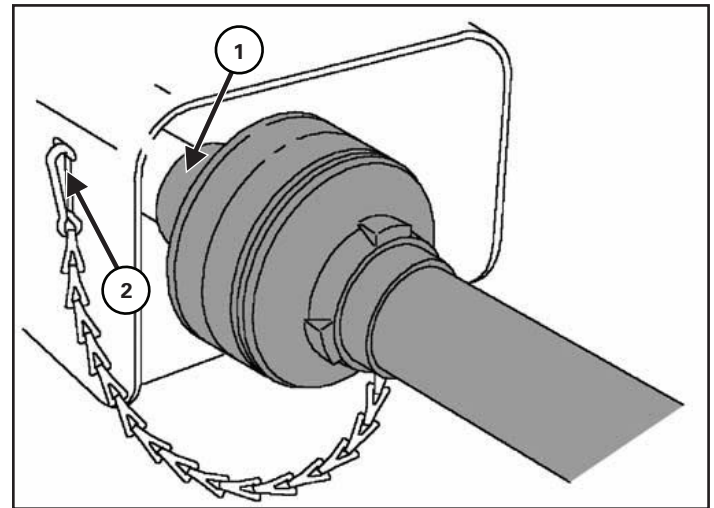

Retract the collar (Item 1) [Figure 13] and slide the PTO driveline onto the tractor PTO shaft. Release the collar and the driveline will lock onto the shaft. Push and pull the PTO driveline back and forth several times and make sure it is securely attached to the PTO shaft.

Install PTO driveline safety chain (Item 2) [Figure 13].

**Note:** The PTO driveline must have a means to retain it to the PTO shaft on the tractor.

	<b>WARNING</b>
	
<ul style="list-style-type: none"> <li>Do NOT exceed 540 RPM PTO.</li> <li>Keep PTO shields and all guards in place.</li> <li>Keep away from moving parts.</li> <li>Keep bystanders away.</li> </ul>	

### PTO Driveline Length Check

Due to variations in distances between tractor PTO shafts and implement input shafts, drivelines may need to be shortened or a longer shaft may be required.

When fitting the implement to the tractor, the PTO driveline, with telescoping sections, must be inspected. When the sections are at the most compressed operating position, the sections must not "bottom out".

At its shortest length, there must be at least 2 in. (50.8 mm) of clearance between each section end and opposite section end at the most compressed operating position.

When the sections are at the most extended position, there must be sufficient engagement between the sections.

At its farthest operating extension, a minimum section engagement of 33% of shaft length must be maintained.

	WARNING
AVOID INJURY OR DEATH	
<ul style="list-style-type: none"> <li>• Do NOT exceed the rated implement PTO speed.</li> <li>• Stay clear of rotating driveline.</li> <li>• Keep bystanders away.</li> <li>• Keep hands, feet, clothing and long hair away.</li> <li>• Keep PTO shields and all guards in place.</li> <li>• Disengage PTO, move the tractor controls to the Neutral position, stop the engine and make sure all rotating components are stopped before leaving the operator's position.</li> <li>• Do NOT service the tractor or implement with the PTO engaged.</li> <li>• Do NOT service the implement in a raised position unless properly blocked and with all rotating components stopped.</li> <li>• Disengage PTO for road travel.</li> </ul>	

### PTO Driveline Bottoming Out Check

Stop the engine and leave the operator's position (See "Leaving The Operator's Position" in Operation section).

Make sure the PTO driveline and all rotating components have come to a complete stop before leaving the operator's position (if applicable).

Figure 14

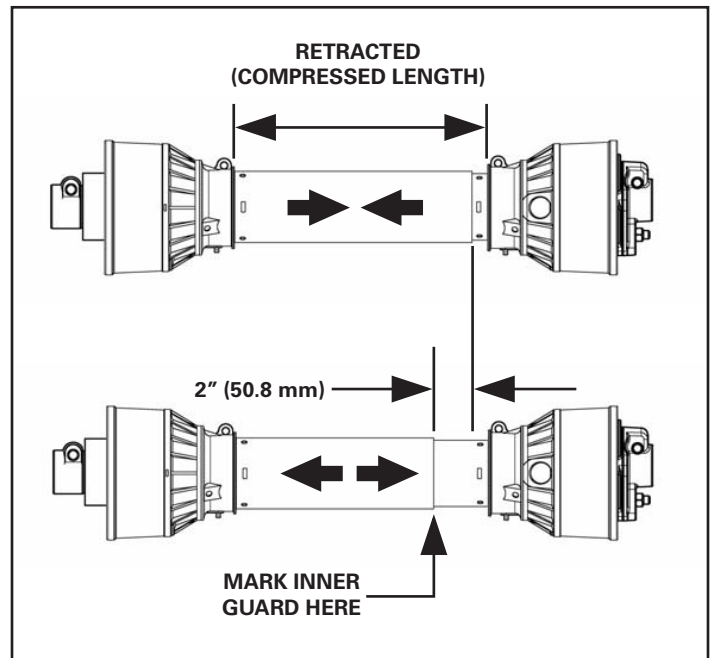

1. Disconnect the PTO driveline from the tractor and slide the PTO driveline together until fully retracted (compressed).
2. Measure the retracted (compressed) length of PTO driveline [Figure 14].
3. Extend the PTO driveline 2 in. (50.8 mm) from the retracted length and place a mark on the inner guard at the end of the outer guard [Figure 14].
4. Reattach the PTO driveline to the tractor PTO shaft.
5. Enter the operator's position. Start the engine.
6. With the rear PTO DISENGAGED, raise and lower the implement and watch the PTO driveline extend and retract.
7. If the outer PTO driveline guard slides in (retracts) over the mark at any point of travel, the PTO driveline needs to be shortened.

### Reducing The PTO Driveline Length

Stop the engine and leave the operator's position (See "Leaving The Operator's Position" in the Operation section). Make sure the PTO driveline and all rotating components have come to a complete stop before leaving the operator's position.

WARNING

AVOID INJURY OR DEATH

- Do NOT exceed the rated implement PTO speed.
- Stay clear of rotating driveline.
- Keep bystanders away.
- Keep hands, feet, clothing and long hair away.
- Keep PTO shields and all guards in place.
- Disengage PTO, move the tractor controls to the Neutral position, stop the engine and make sure all rotating components are stopped before leaving the operator's position.
- Do NOT service the tractor or implement with the PTO engaged.
- Do NOT service the implement in a raised position unless properly blocked and with all rotating components stopped.
- Disengage PTO for road travel.

Remove the PTO driveline from the tractor and place in storage position (if equipped).

Enter the operator's position (See "Entering The Operator's Position" in the Operation section). Start the engine.

Raise or lower the three-point implement to get the shortest distance between the tractor PTO shaft and three-point implement gearbox PTO shaft. Stop the engine and leave the operator's position.

Pull the PTO driveline apart and reinstall each individual section; one half to the tractor PTO shaft and one half to the implement gearbox PTO shaft.

**Figure 15**

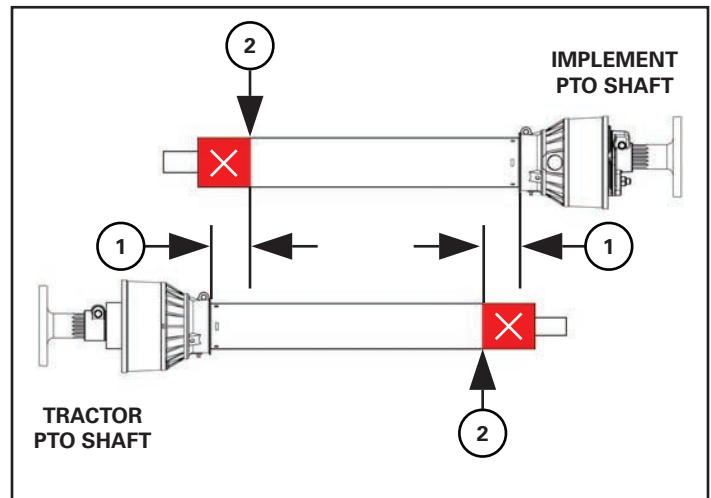

1. Hold PTO driveline sections parallel to one another and measure back 2 in. (50.8 mm) (Item 1) [Figure 15] from the yoke of each section and place mark on opposite section. Cut the plastic shield at this length (Item 2) [Figure 15].

**Figure 16**

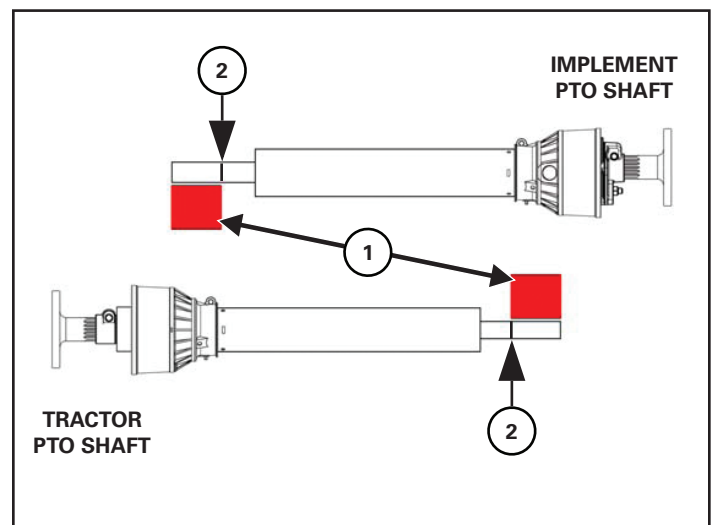

2. Using the plastic guard lengths that were cut off in [Figure 15], align the cut off lengths (Item 1) [Figure 16] with the end of the inner & outer shafts. Place a mark (Item 2) [Figure 16] on the inner & outer shafts and cut the inner & outer shafts off at this length.
3. Round off all sharp edges and deburr.
4. Thoroughly grease and install the PTO driveline halves together.
5. Recheck for proper operation.

### PTO Driveline Engagement Check

Stop the engine and leave the operator's position (See "Leaving The Operator's Position" in the Operation section).

Make sure the PTO driveline and all rotating components have come to a complete stop before exiting the tractor.

	WARNING
AVOID INJURY OR DEATH	
<ul style="list-style-type: none"> <li>• Do NOT exceed the rated implement PTO speed.</li> <li>• Stay clear of rotating driveline.</li> <li>• Keep bystanders away.</li> <li>• Keep hands, feet, clothing and long hair away.</li> <li>• Keep PTO shields and all guards in place.</li> <li>• Disengage PTO, move the tractor controls to the Neutral position, stop the engine and make sure all rotating components are stopped before leaving the operator's position.</li> <li>• Do NOT service the tractor or implement with the PTO engaged.</li> <li>• Do NOT service the implement in a raised position unless properly blocked and with all rotating components stopped.</li> <li>• Disengage PTO for road travel.</li> </ul>	

1. Disconnect the PTO driveline from the tractor and fully slide the driveline sections together (retracted).
2. Measure the retracted (compressed) length of the PTO driveline between the bases of the plastic guards [Figure 17].
3. Multiply the retracted driveline length by 1.667 to determine the PTO driveline Maximum Operating Length. (i.e.: 25.5 in. (647.7 mm) x 1.667= 42.5 in. (1079.7 mm) Maximum Operating Length).
4. Attach the PTO driveline to the tractor PTO output shaft.
5. Enter the operator's position. (See "Entering The Operator's Position" in the Operation section)

6. With the PTO driveline attached, position the three-point implement to where the telescoping PTO driveline is at its maximum operating extension.
7. Stop the engine and leave the operator's position. Make sure the PTO driveline and all rotating components have come to a complete stop before leaving the operator's position.
8. Measure the length of the PTO driveline between the bases of the plastic shields [Figure 17] to determine the maximum operating length.

If the measured maximum operating length is less than the Maximum Operating Length calculation (from Step 3), the PTO driveline has adequate engagement

If the measured maximum operating length is equal to or more than the Maximum Operating Length calculation (from Step 3), the PTO driveline does not have adequate engagement and should be replaced with a longer driveline. See your Farm King dealer for available PTO drivelines.

Figure 17

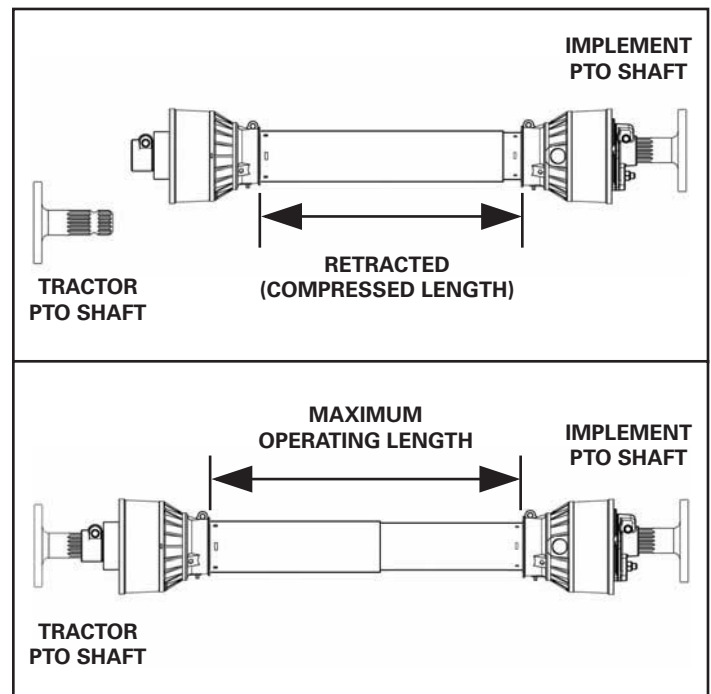





## Connecting Hydraulic Hoses

The snowblower may be equipped with the following hydraulic options, if applicable.

1. Hydraulic spout deflector
2. Hydraulic discharge chute

Push couplers into female couplers on the tractor until they are fully engaged and locked.

	WARNING
	
<b>HIGH PRESSURE FLUID HAZARD</b>	
<p>To prevent serious injury or death from high pressure fluid:</p> <ul style="list-style-type: none"> <li>• Relieve pressure on system before repairing or adjusting.</li> <li>• Wear proper hand and eye protection when searching for leaks. Use wood or cardboard instead of hands.</li> <li>• Keep all components in good repair.</li> </ul>	

	IMPORTANT
<p>Contain and dispose of any oil leakage in an environmentally safe manner.</p> <p>Thoroughly clean the quick couplers before making connections. Dirt can quickly damage the system.</p>	

**Note:** Make sure the quick couplers are fully engaged. If the quick couplers do not fully engage, check to see that the couplers are the same size and type.

## Disconnecting Hydraulic Hoses

Release pressure and pull the male couplers out to disconnect.

	WARNING
<b>AVOID BURNS</b>	
<p>Hydraulic fluid, tubes, fittings and quick couplers can get hot when running equipment. Be careful when connecting and disconnecting quick couplers.</p>	



## Adjusting Skid Shoe Height

	WARNING
<p><b>AVOID INJURY OR DEATH</b></p> <p><b>Before you leave the operator's position:</b></p> <ul style="list-style-type: none"> <li>• Always park on a flat level surface.</li> <li>• Place all controls in NEUTRAL.</li> <li>• Engage the park brake.</li> <li>• Stop the engine and remove the key.</li> <li>• Wait for all moving parts to stop.</li> </ul>	

	WARNING
<p><b>AVOID INJURY OR DEATH</b></p> <p><b>Securely block up the implement before working underneath.</b></p>	

Park the tractor and implement on a flat level surface.

Fully raise the snowblower.

Stop the engine and leave the operator's position. (See "Leaving The Operator's Position" in the Operation section). Make sure the PTO driveline and all rotating components have come to a complete stop before leaving the operator's position.

Place blocking under the snowblower. Position blocking away from skid shoes, allowing access to skid shoe mounting bolts and nuts.

Enter the operator's position. (See "Entering The Operator's Position" in the Operation section). Start the engine.

Lower the snowblower onto the blocking.

Stop the engine and leave the operator's position.

Skid Shoe Settings:

**Decrease Working Depth** - Lower skid shoes.

**Increase Working Depth** - Raise skid shoes.

Figure 18

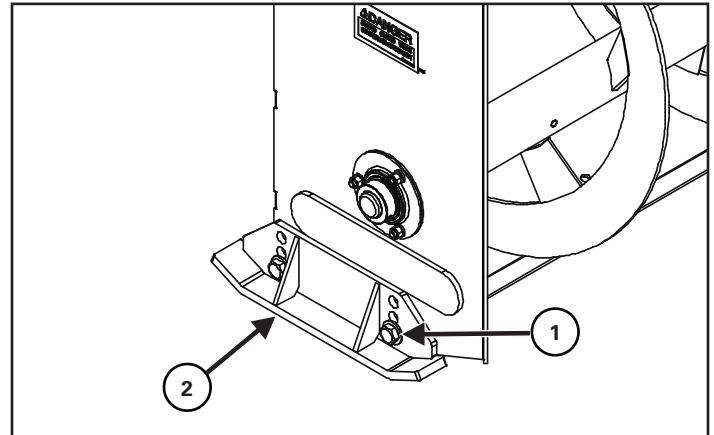

Loosen bolt(s) and nut(s) (Item 1) [Figure 18] on the skid shoe (Item 2) [Figure 18]. Raise or lower the skid shoe to the desired depth setting. Reinstall bolts and nuts to secure the skid shoe in position.

**Note: Skid shoes must be level from front to back. Left and right skid shoes must be set at the same working depth.**

Repeat procedure on opposite skid shoe.

Verify both skid shoes are set at the same depth setting.

## Theory Of Operation



# CAUTION

- Read operator and parts manual before operating the implement.
- Do not permit riders.
- Keep all guards and shields in place.
- Keep hands, feet, clothing and hair away from moving parts.
- Stop engine, set brake, remove key and wait for all moving parts to stop before servicing, adjusting, repairing and unplugging.
- Remove bystanders, especially children, before starting or while operating.
- Block up before working beneath unit.
- Review safety instructions annually.
- Operate only at 540 RPM.

FAN BLADE ROTATION

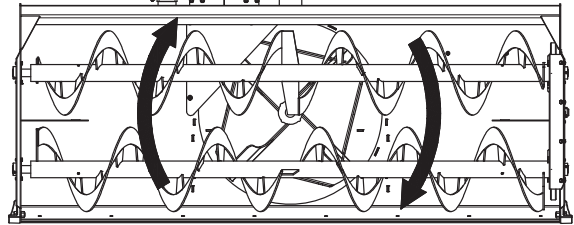

SPOUT ROTATION

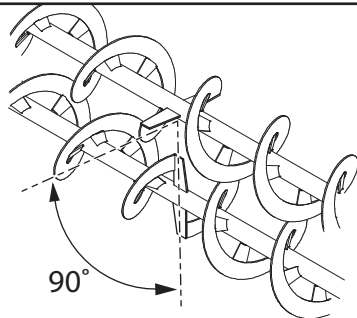
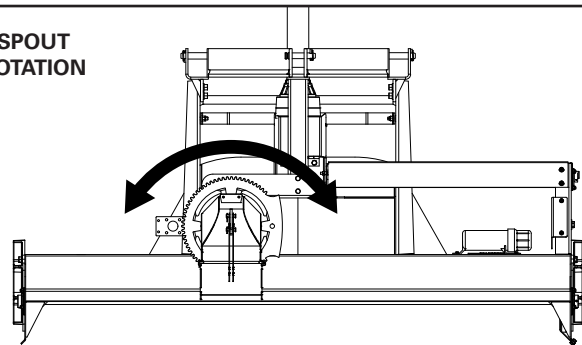

The dual augers must be positioned so the center paddles are offset 90°.

Contact your dealer for proper adjustment.

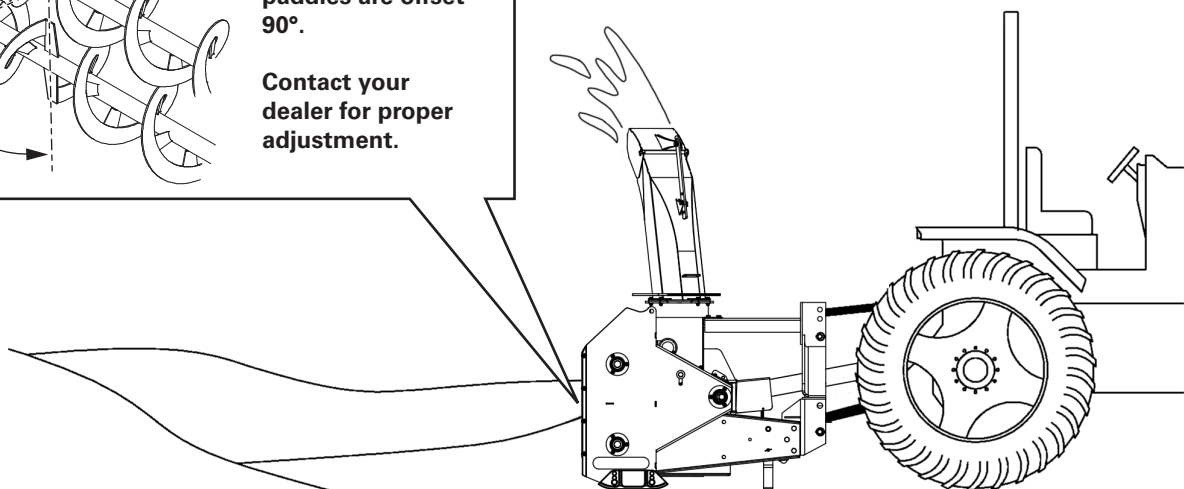



↑  
UNCLEARED SNOW

↑  
CLEARED SNOW

## Transporting

Always comply with federal, state, local and provincial laws regarding the transport of farm equipment on public roadways.

	<b>WARNING</b>
<b>AVOID INJURY OR DEATH</b>	
<ul style="list-style-type: none"> <li>• Disengage PTO for road travel.</li> <li>• Keep PTO shields and all guards in place</li> <li>• Keep bystanders away.</li> <li>• Do not allow riders.</li> <li>• Always use hazard flashers on the tractor when transporting unless prohibited by law.</li> <li>• Always follow local regulations when transporting on public roadways. Check with your local authorities.</li> </ul>	

	<b>IMPORTANT</b>
<b>Never exceed 20 mph (32 kph).</b>	

	<b>WARNING</b>
<p><b>Use of an unapproved hitch or tractor / tow vehicle can result in loss of control, leading to serious injury or death.</b></p> <p><b>Tractor / tow vehicle and hitch must have the rated capacity to tow equipment.</b></p>	

Verify that the tractor / tow vehicle is approved for transporting the equipment and that the equipment is securely attached to the tractor / tow vehicle.

Verify safety chain is installed and properly connected before transporting equipment.

Verify that the SMV (Slow Moving Vehicle) emblem, all lights and reflectors are clean and visible.

The ratio of the tractor / tow vehicle weight to the loaded equipment weight plays an important role in defining acceptable travel speed.

TRAVEL SPEED - Acceptable travel speed.

WEIGHT RATIO - Weight of fully equipped or loaded implement(s) relative to weight of tractor / tow vehicle.

Travel Speed	Weight Ratio
20 mph (32 kph)	Less than 1 to 1
10 mph (16 kph)	Less than 2 to 1
DO NOT TOW	More than 2 to 1

# Farm King



# Maintenance

Service Schedule Chart.....43

Lubrication.....44

    Recommendations.....44

    Locations.....44

    Oil Bath Gearbox.....46

Chains And Fasteners.....46

Safety Sign (Decal) Installation.....47

Storage And Return To Service.....47

    Storage.....47

    Return To Service.....48

# Farm King





## Service Schedule Chart

	WARNING
<p><b>Instructions are necessary before operating or servicing equipment. Read and understand the Operator And Parts Manual and safety signs (decals) on equipment. Follow warnings and instructions in the manuals when making repairs, adjustments or servicing. Check for correct function after adjustments, repairs or service. Untrained operators and failure to follow instructions can cause injury or death.</b></p>	

**Note:** If a problem is encountered that is difficult to solve, even after having read through this troubleshooting section, please call your local distributor, dealer or factory. Before you call, please have this Operator And Parts Manual and the serial number of your machine at hand.

Maintenance work must be done at regular intervals. Failure to do so will result in excessive wear and early failures. The service schedule is a guide for correct maintenance of the snowblower.

#	DESCRIPTION	SERVICE PROCEDURES					
		CHECK	CLEAN	LUBE	CHANGE	COVER	DRAIN
Daily Maintenance (or every 8 hours)							
1	PTO Cross and Bearings	✓		✓			
Weekly (or every 50 hours)							
2	PTO Telescoping Tubes			✓			
3	Slip Clutch Connector			✓			
4	PTO Quick Disconnect			✓			
5	Spout Ring & Clamps			✓			
6	Chain Drive			✓			
7	Oil Bath Gearbox	✓					
Annually (or every 500 hours)							
8	Driveline & Gears	✓		✓			
9	Machine	✓	✓				
10	Oil Bath Gearbox	✓			✓		



## Lubrication

### Recommendations

Always use a good quality multi-purpose / lithium base grease when lubricating the equipment.

- Always use a hand-held grease gun.
- Clean fitting before greasing, to avoid injecting dirt and grit.
- Replace and repair broken fittings immediately.
- If fittings will not take grease, remove and clean thoroughly. Replace fitting if necessary.

WARNING

AVOID INJURY OR DEATH

**Stop engine, set brake, remove ignition key, and wait for all moving parts to stop before servicing, adjusting, repairing, or unplugging.**

**Support the equipment with blocks or safety stands before working beneath it.**

**Follow good shop practices:**

- Keep service area clean and dry
- Be sure electrical outlets and tools are properly grounded
- Use adequate light for the job.

**Use only tools, jacks, and hoists of sufficient capacity for the job.**

**Replace and secure all shields removed during servicing before operating.**

**Use heavy leather gloves to handle sharp objects.**

**Check hydraulics regularly for leaks. Use cardboard to look for leaks, and use hand and eye protection.**

**Relieve pressure on hydraulic system before repairing or adjusting.**

### Locations

!

IMPORTANT

**Fluid such as engine oil, hydraulic fluid, coolants, grease, etc. must be disposed of in an environmentally safe manner. Some regulations require that certain spills and leaks on the ground must be cleaned in a specific manner. See local, state and federal regulations for the correct disposal.**

Figure 19

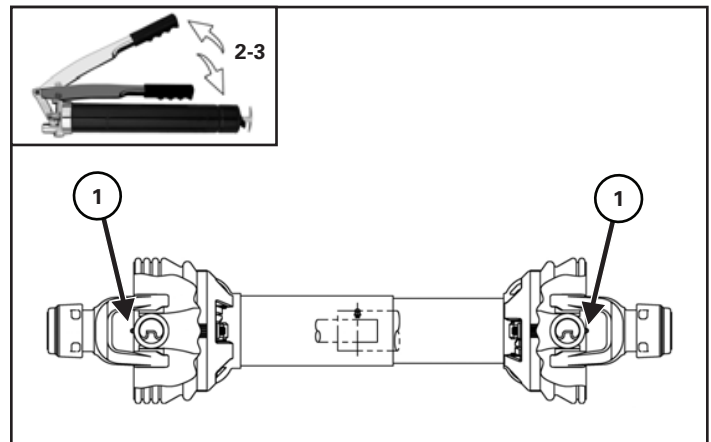

Apply two to three pumps of grease to the cross and bearings (Item 1) [Figure 19] on the PTO driveline. Grease every **8 hours**.

**Note:** Images may not show your exact PTO driveline but the procedure is correct.

**Figure 20**

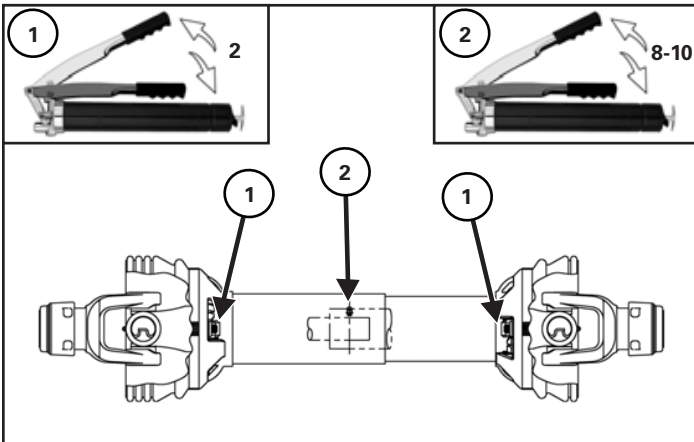

Apply two pumps of grease to the guard bushings (Item 1) [Figure 20].

Apply eight to ten pumps of grease to the telescoping member (Item 2) [Figure 20].

Grease every **50 hours**.

**Figure 21**

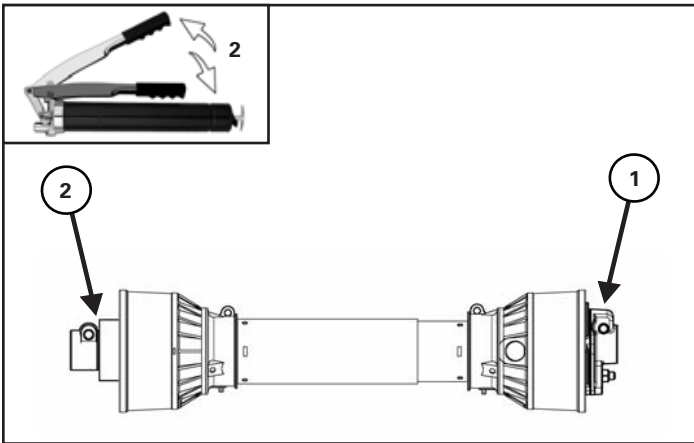

Apply two pumps of grease to the slip clutch (Item 1) [Figure 21] and PTO quick disconnect (Item 2) [Figure 21].

Grease every **50 hours**.

**Figure 22**

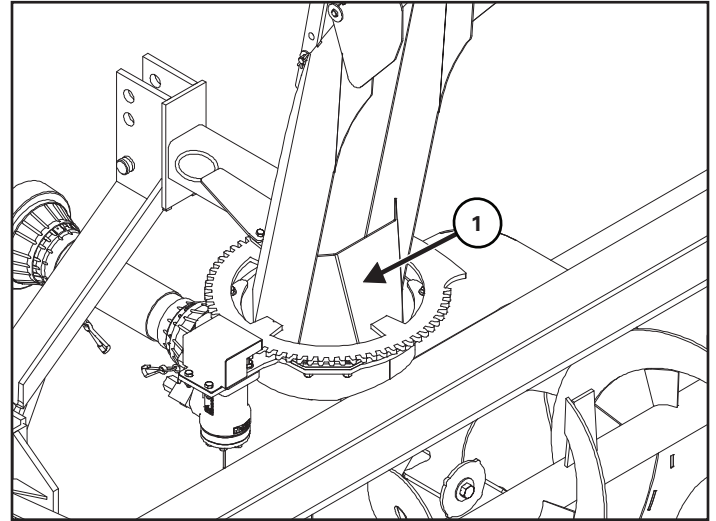

Apply grease to spout clamps and rings connecting the spout (Item 1) to the main body [Figure 22].

Grease every **50 hours**.

**Figure 23**

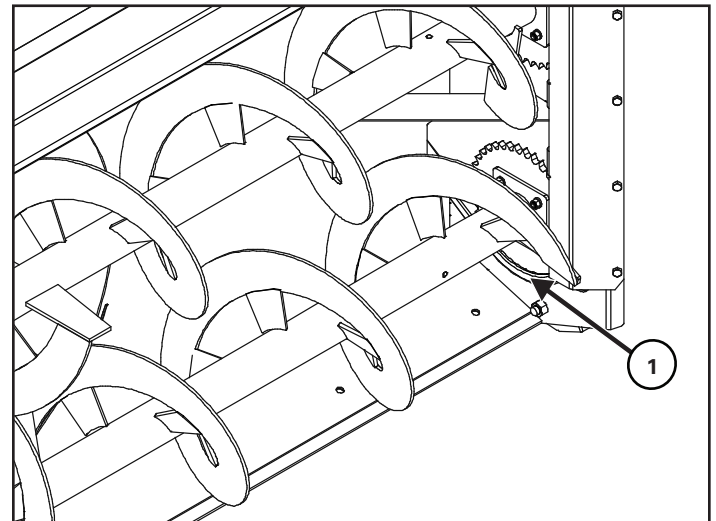

Apply chain lube to chain drive (Item 1) [Figure 23].

Grease every **50 hours**.

## Oil Bath Gearbox

Figure 25

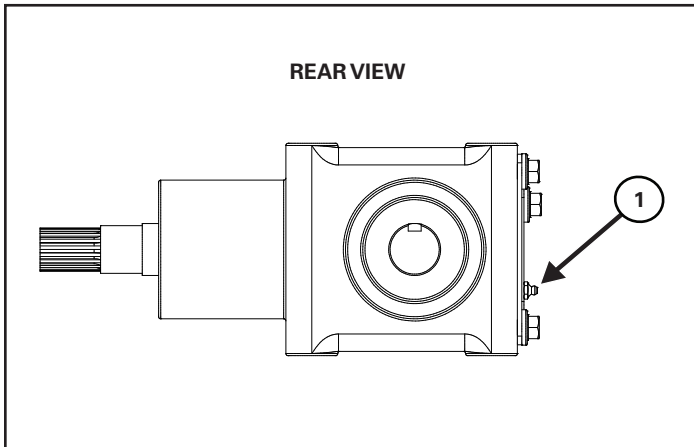

Check the oil level using the plug on the lid (Item 1) [Figure 25].

The correct level is even with the bottom of the plug.

Add SAE 80W-90 gear oil if the oil level is low.

Check oil level every **50 hours**.

## Chains And Fasteners

Periodically check all bolts and fasteners for tightness.

Figure 24

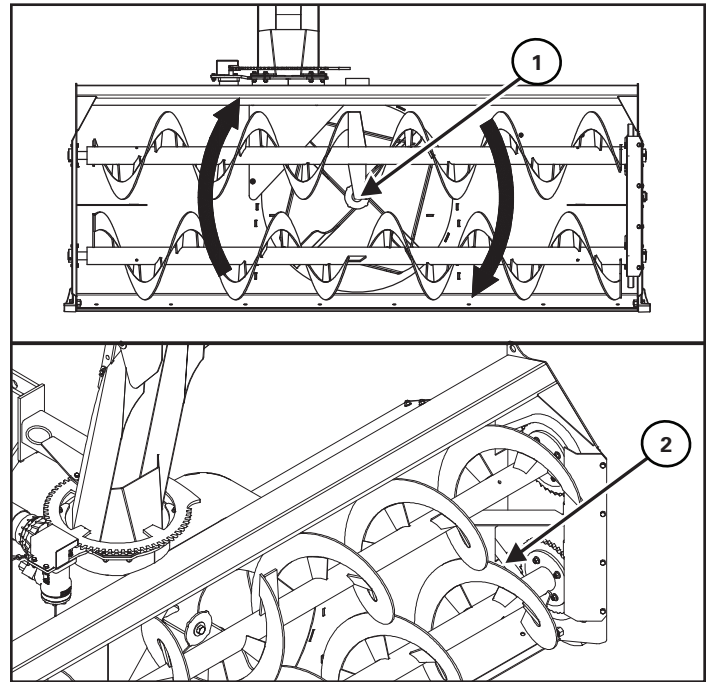

Check the main fan bolt (Item 1) [Figure 24] for tightness.

Check the tension in the drive chain (Item 2) [Figure 24]. Slack on the lower side of the chain should be 3/8" to 1/2".

### Check the shear bolts on the PTO driveline.

96" models:

- 3/8" x 2-1/4" GR5 (STD PTO)
- 3/8" x 2-1/4" GR5 (LONG PTO OPT)

Shear bolts should be fastened with a lock nut or two jam nuts. These bolts must be kept tight to prevent wear of the bolt and bolt holes.

## Safety Sign (Decal) Installation



- Remove all portions of the damaged safety sign (decal).
- Thoroughly clean the area with adhesive remover and glass cleaner. Remove all adhesive residue.
- Allow the area to dry completely before installing the new safety sign (decal).
- Position the safety sign (decal) in the correct location.
- Remove a small portion of the backing paper on the safety sign (decal).
- Press on the safety sign (decal) where the backing paper has been removed.
- Slowly remove the remaining backing paper, pressing on the safety sign (decal) as the backing paper is removed.
- Using the backing paper, pressing firmly, move the backing paper over the entire safety sign (decal) area.

**Note:** Small air pockets can be pierced with a pin and smoothed out using the piece of the backing paper.

## Storage And Return To Service

### Storage

Sometimes it may be necessary to store your Farm King snowblower for an extended period of time. Below is a list of items to perform before storage.



- Thoroughly wash the machine with a pressure washer or water hose to remove all dirt, mud, debris or residue.
- Lubricate all bushings to remove any water residue from washing.
- Remove any material that has become entangled around any moving part.
- Place hydraulic hoses or electrical connector (if applicable) in the storage brackets.
- Inspect the hitch and all welds on the equipment for wear and damage.
- Check for loose hardware, missing guards, or damaged parts.
- Check for damaged or missing safety signs (decals). Replace if necessary.
- Replace worn or damaged parts.
- Touch up all paint nicks and scratches to prevent rusting.
- Place the equipment in a dry protected shelter.

**Note:** If a dry protected shelter is not available, cover with a waterproof tarp and tie down securely.

- Place the equipment flat on the ground.
- Support the jack / frame with planks if required.

## **Return To Service**

After the equipment has been in storage, it is necessary to follow a list of items to return the equipment to service.

- Be sure all shields and guards are in place.
- Lubricate the equipment.
- Connect to a tractor and operate equipment, verify all functions operate correctly.
- Repair as needed.

## Parts Identification

Always give your dealer the Model, Color and Serial Number of your machine to assist them in ordering and obtaining the correct parts. Use the exploded view and tabular listing of the area of interest to exactly identify the required part.

Main Components.....	51
Discharge Spout.....	54
Hydraulic Spout Rotator - F1545.....	56
Cutting Edge (Option) - X3897.....	57
Oil Bath Gearbox - BU50505.....	58
PTO Shaft - F1696 .....	60
PTO Shaft Long - F1695.....	61
Hydraulic Spout Deflector Cylinder 1.75" x 5" (Option).....	62
Additional Components.....	63

# Farm King





# Main Components

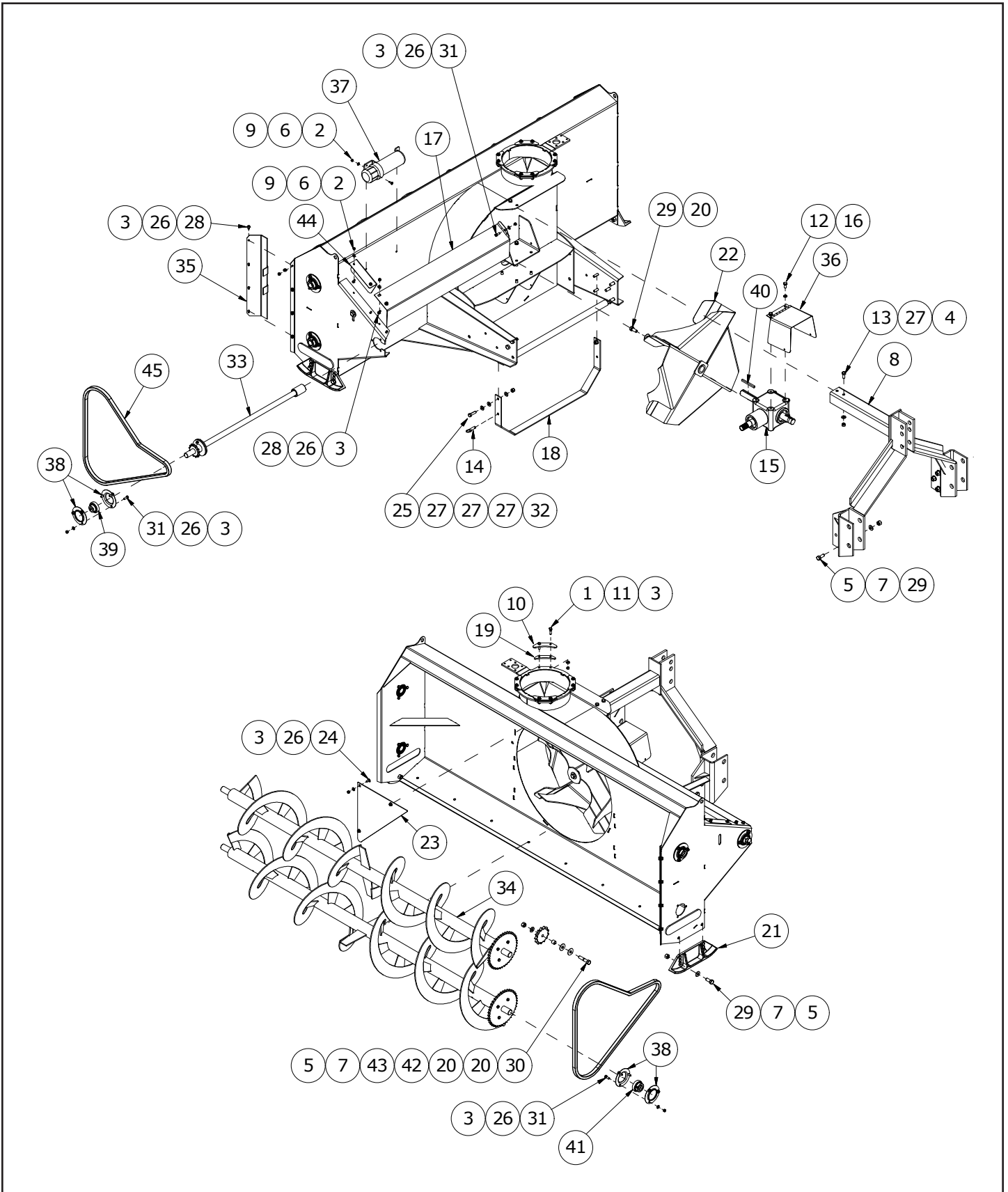

ITEM	PART NUMBER	DESCRIPTION	QTY.
1	811792	3/8" X 1 1/2" HEX BOLT GR.5 (PL)	8
2	812362	5/16" LOCK NUT (PL)	4
3	812363	3/8" LOCK NUT (PL)	33
4	812364	1/2" LOCK NUT (PL)	2
5	812482	5/8" LOCK NUT (PL)	11
6	812623	WASHER - 5/16" SAE FLAT (PL)	4
7	812639	WASHER 0.625 SAE FLAT BS PL	11
8	F1530	QUICK HTCH WELDT	1
9	81549	5/16" X 3/4" HEX BOLT (PL)	4
10	819886	96" SPOUT CLAMP	4
11	81570	WASHER - 5/16" STD FLAT (PL)	8
12	81619	1/2" X 1" HEX BOLT (PL)	8
13	81620	1/2" X 1 1/4" HEX BOLT PL	2
14	816268	1/2" X 1" (USABLE LENGTH) DETENT PIN	2
15	BU50505	GEARBOX ASSY	1
16	81637	1/2" LOCKWASHER (PL)	8
17	816477	16GA DR SHFT GUARD	1
18	816516	96" PARKING STAND	1
19	819883	96 SPOUT SPACER	4
20	81678	5/8" FLAT WASHER STD (PL)	3
21	817162	SB CAST SKID SHOE	2
22	818362	WELDMENT - 96" FAN	1
23	818987	PLATE - 96" FAN SHIELD	1
24	81914	3/8" X 1" CARRIAGE BOLT (PL)	3
25	81966	NUT LOCK (NYLON) 0.500NC PL	2
26	84039	WASHER - 3/8" SAE FLAT (PL)	25
27	84048	1/2" SAE FLAT WASHER (PL)	8
28	84072	3/8" X 3/4" HEX BOLT (PL)	6
29	84268	5/8" X 1 1/2" HEX BOLT (PL)	11
30	84289	5/8" X 3" HEX BOLT GR.5 (PL)	1
31	86170	3/8" X 1" HEX BOLT GR.5 (PL)	16
32	87553	1/2" X 1.75" HEX BOLT UNC GR5 (PL)	2
33	901828	ASSEMBLY - 96" SB DRIVE SHAFT	1
34	901844	ASSEMBLY - 96" PTO STD AUGER	2
	817314	ASSEMBLY - 96" PTO PR AUGER	2
35	901847	CHAIN GUARD 10GA X 5 1/2" X 24"	1
36	908715	PTO SHLD WELDT	1
37	909277	MANUAL HOLDER	1
38	961675	BEARING FLANGE 72MS	10
39	961676	1 1/4" BEARING AEL207-104 (RHP #1230)	1
40	965814	3/8" X 3/8" X 4 1/4" FAN SHFT KEY	1

ITEM	PART NUMBER	DESCRIPTION	QTY.
41	965917	1 3/8" BEARING	4
42	965928	BUSHING - 0.84"OD X 0.109"W X 0.75"	1
43	965962	#60 13T SPRKT	1
44	965968	14GA X 7 1/2" X 8" IDLER SHLD	1
45	965972	ROLLER CHAIN #60 X 117 W/ C & O	1

## Discharge Spout

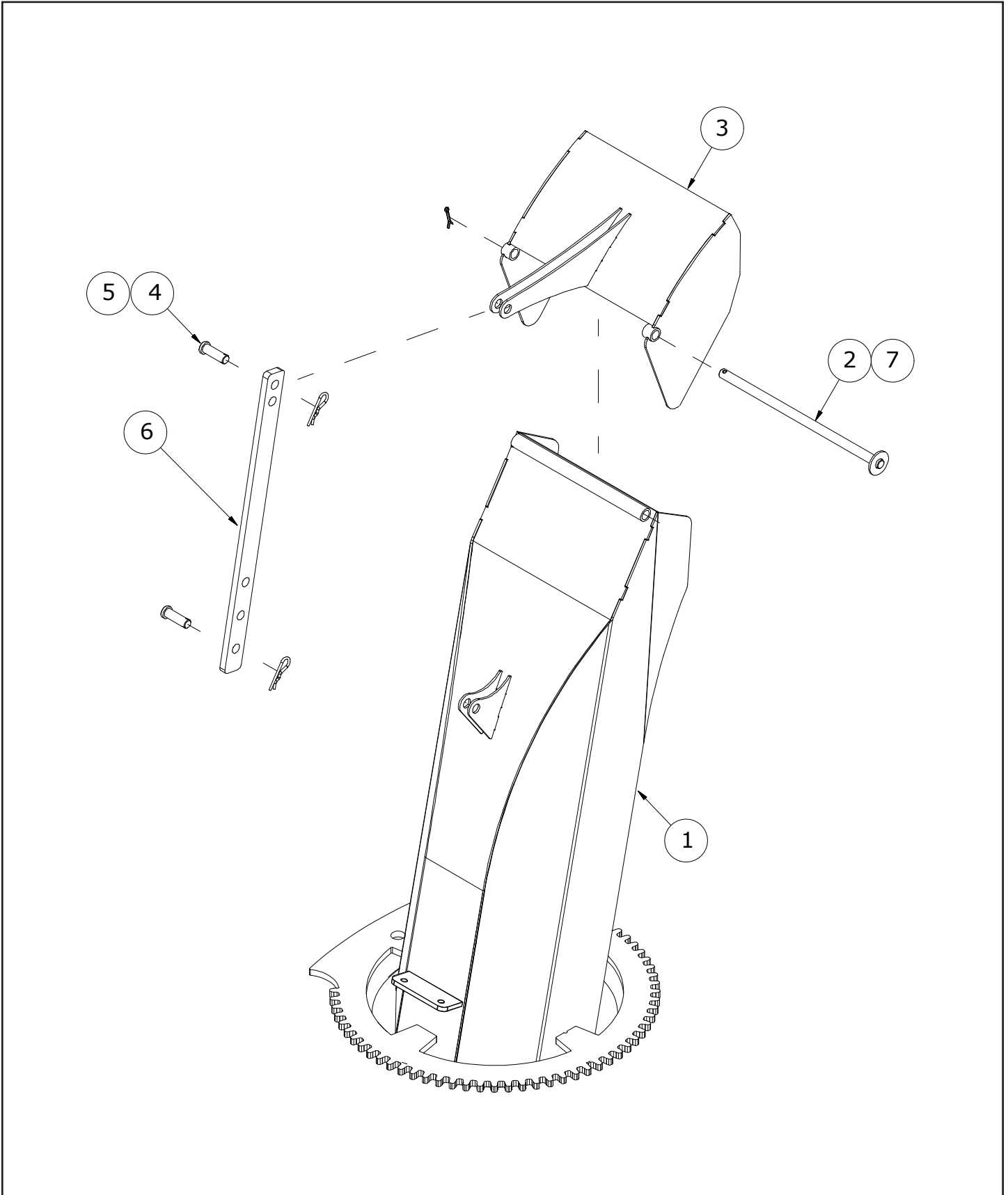

ITEM	PART NUMBER	DESCRIPTION	QTY.
1	818481	WELDMENT - 96" SPOUT BODY	1
2	818482	WELDMENT - 96" DEFLECTOR HINGE ROD	1
3	818483	WELDMENT - 96" DEFLECTOR	1
4	961012	#16 HAIR PIN CLIP	2
5	961876	1/2" X 1 1/2" CLEV PIN (PL)	2
6	965646	1/2" X 1 1/4" X 18" ADJ BAR	1
7	9812430	1/8" X 1" COTTER PIN (PL)	1

## Hydraulic Spout Rotator - F1545

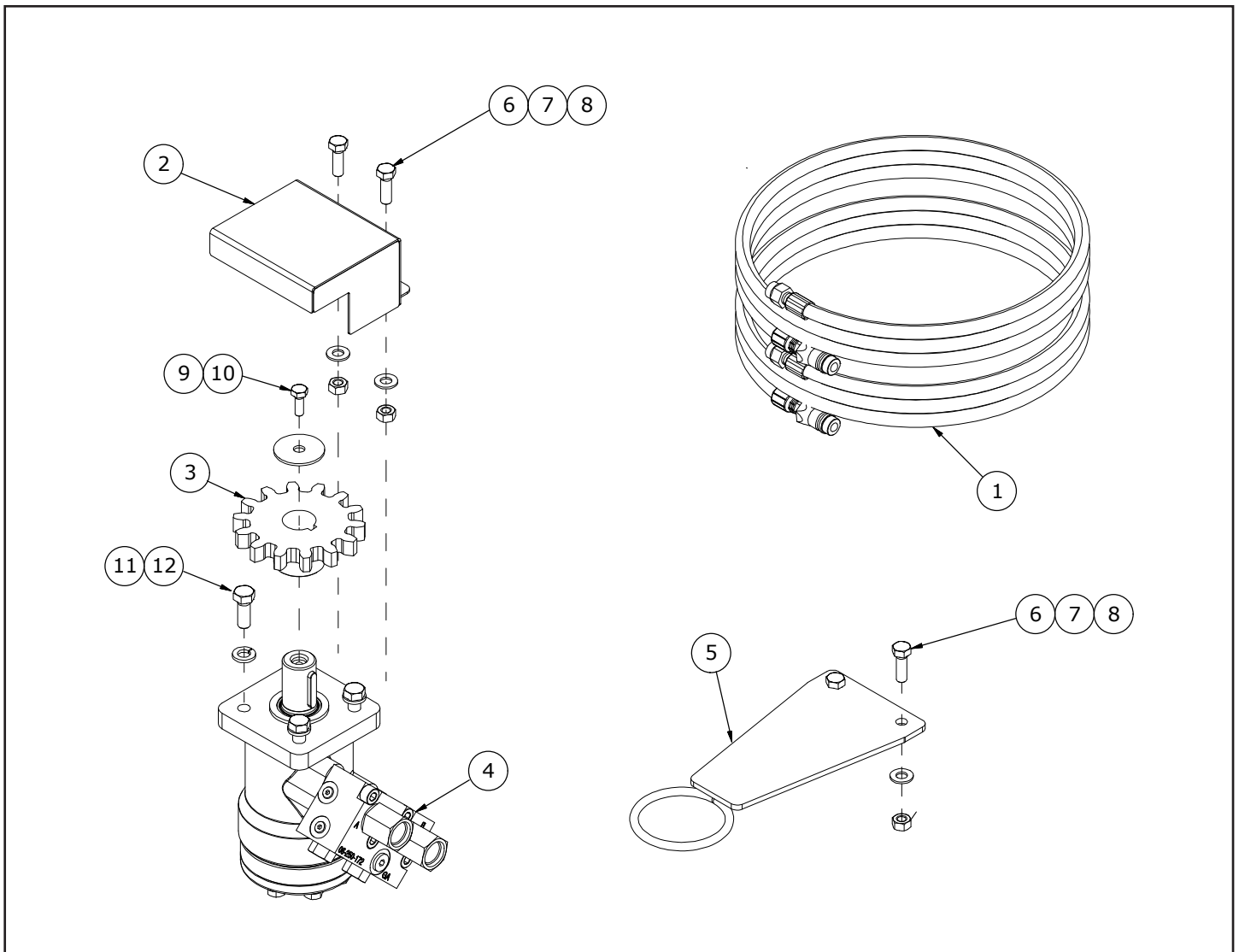

ITEM	PART NUMBER	DESCRIPTION	QTY.
1	816682	PTO MODELS HYD SPOUT ROTATION HOSE	2
2	816840	GEAR GUARD WELDT	1
3	817014	PINION GEAR 14TEETH	1
4	818903	ASSEMBLY - MOTOR & MANIFOLD	1
5	907590	SPT HOSE HLDR WELDT	1
6	812026	5/16" X 1" HEX BOLT (PL)	4
7	812362	5/16" LOCK NUT (PL)	4
8	812623	WASHER - 5/16" SAE FLAT (PL)	4
9	813748	WASHER, FENDER, 1 1/2"OD X 5/16"ID (PL)	1
10	81525	1/4" X 3/4" HEX BOLT (PL)	1
11	81593	3/8" LOCK WASHER (PL)	4
12	86170	3/8" X 1" HEX BOLT GR.5 (PL)	4

**Cutting Edge (Option) - X3897**

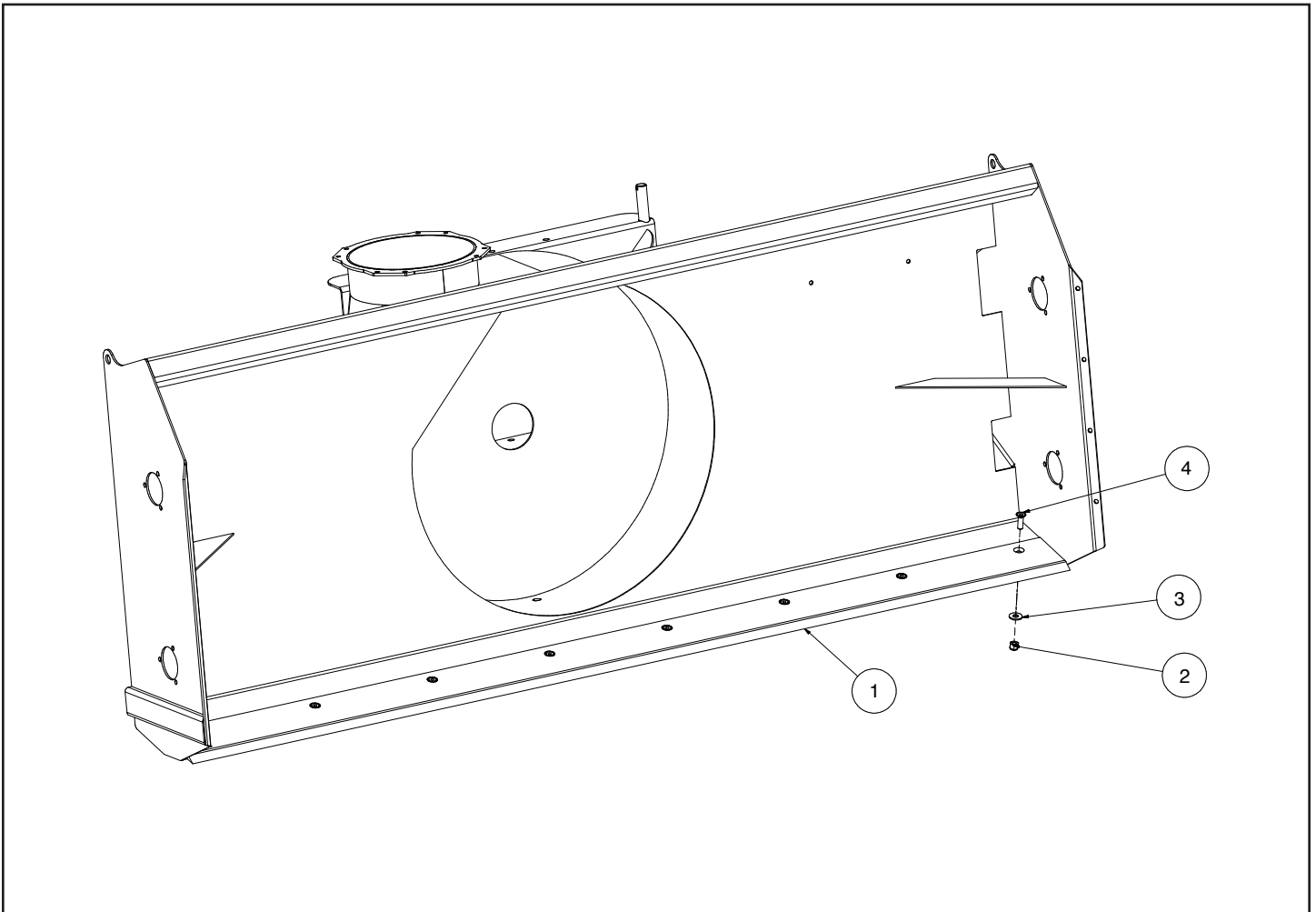

ITEM	PART NUMBER	DESCRIPTION	QTY.
1	816325	CUTING EDGE - 96" SNOWBLOWER	1
2	81966	NUT LOCK (NYLON) 0.500NC PL	8
3	84048	WASHER 0.500 FLAT SAE Bs PL	8
4	906655	1/2" x 1-1/2" FL HD BOLT (SKT) (PL)	8



# Oil Bath Gearbox - BU50505

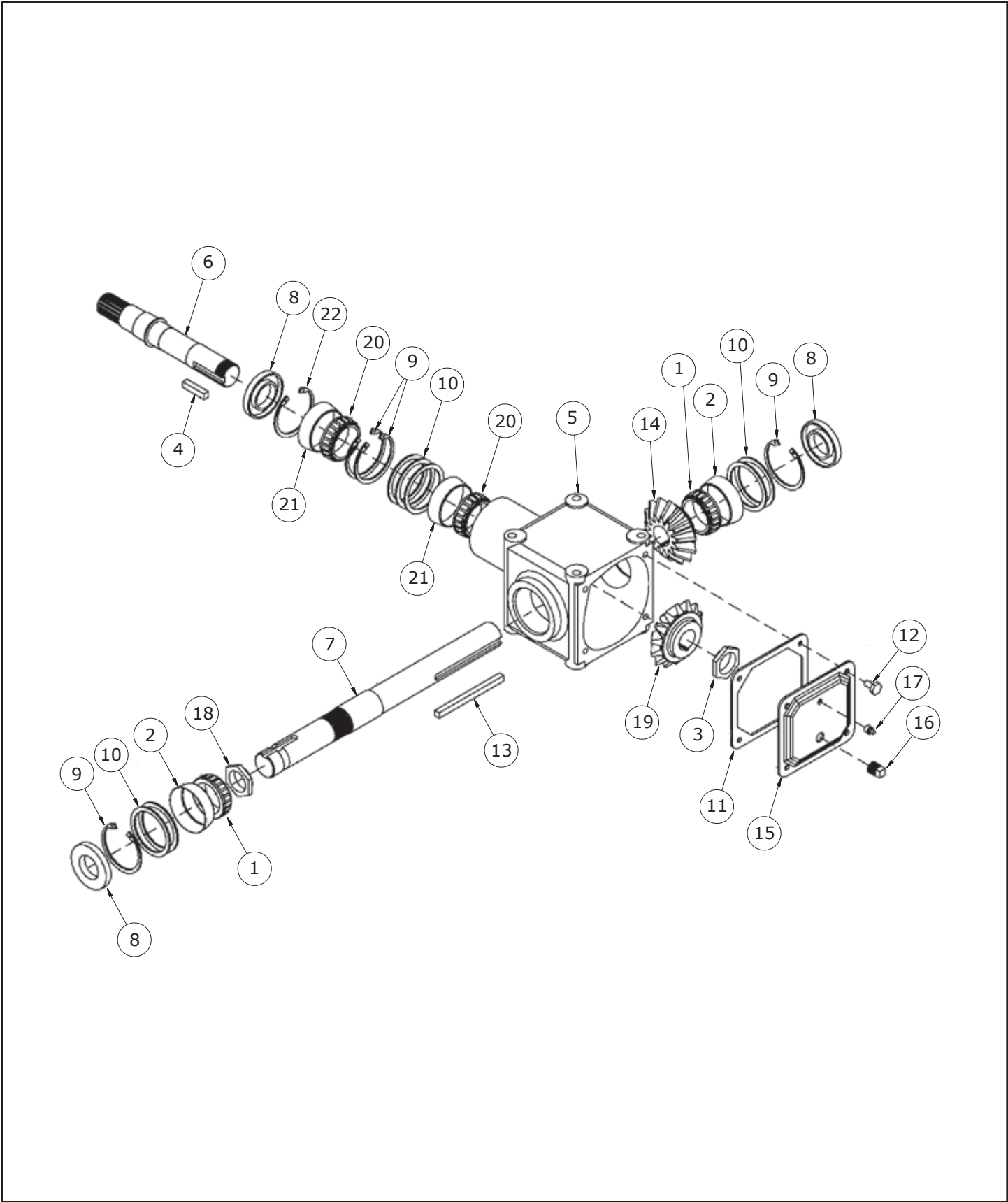

ITEM	PART NUMBER	DESCRIPTION	QTY.
1	BU575901	BRG CONE (13687)	2
2	BU575902	BRG CUP (13620)	2
3	BU50444	STAKING LOCKNUT 1 3/8	1
4	BU50417-1	KEY .38"SQX1.38" BA,CW,SB	1
5	BU50310	CASTING GEAR BOX	1
6	BU50502	PINION SHAFT SPLINED-STRAIGHT	1
7	BU50507	CROSS SHAFT S/B-Y960Q-'92 & UP	1
8	BU50422-1	OIL SEAL 2.72X1.50X0.37	3
9	BU50415	RING RETAINER EATON# IN-275	4
10	BU50210X	SHIM KIT	1
11	BU50458	GEAR BOX GASKETS	1
12	BU500397-6	BOLT HEX 0.313NC X 0.63GR5 PL	4
13	BU50429	KEY	1
14	BU50329	GEAR BEVEL 1.5"B 17T C 149	1
15	BU50457	GEAR BOX COVER	1
16	BU500089-3	PLUG SQ HD 3/8 NPT STEEL (CUSTOM)	1
17	BU500167-1	VALVE RELIEF 1/8 NPTF	1
18	BU50428	STAKING LOCKNUT 1 5/8	1
19	BU50331	GEAR BEVEL 1.375"B 17T C 149	1
20	BU575906	BRG CONE (14137A)	2
21	BU575907	BRG CUP (14276)	2
22	BU278811	RET-RING WALDES 5160-137	1

## PTO Shaft - F1696

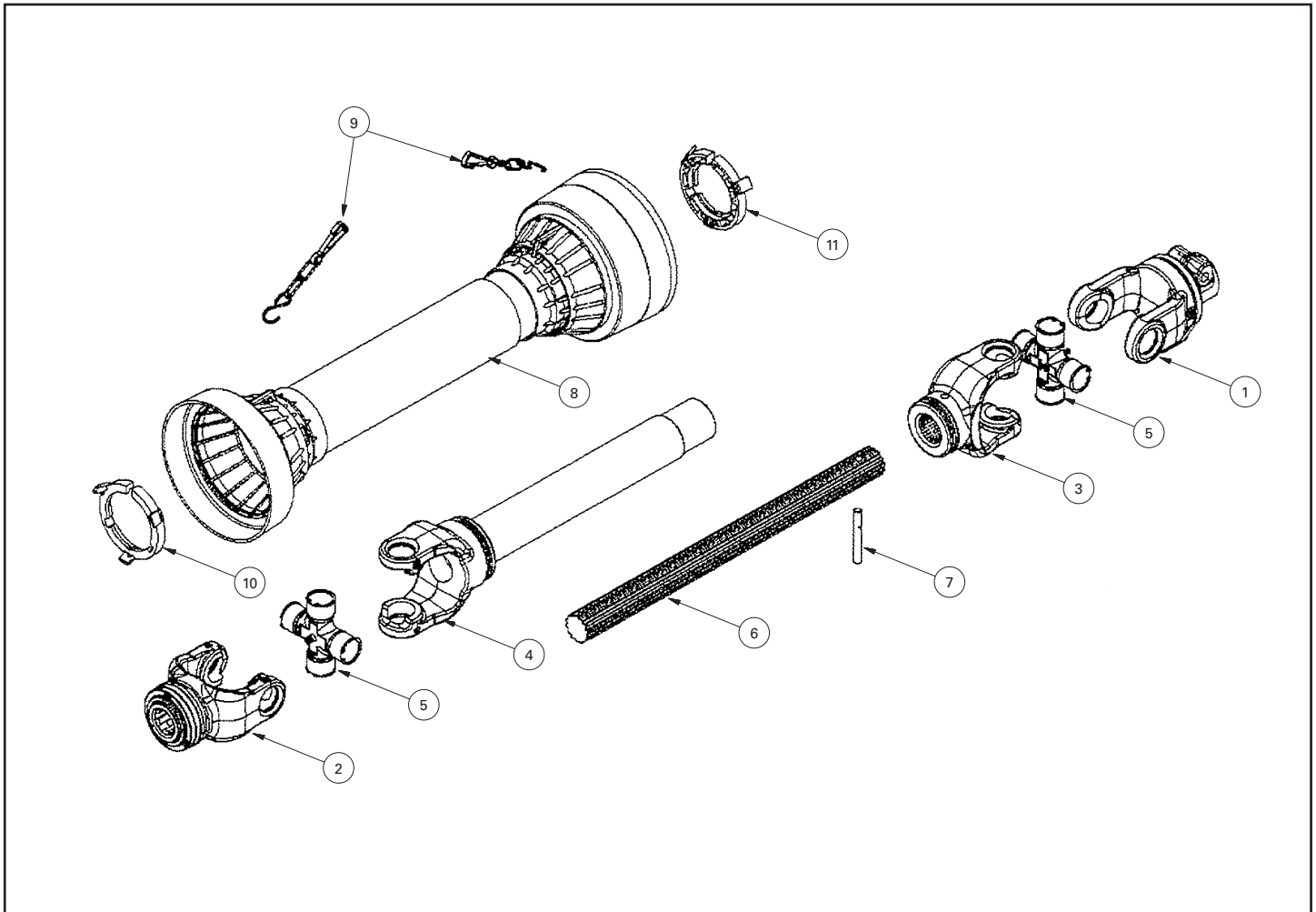

ITEM	PART NUMBER	DESCRIPTION
1	817790	SHEAR BOLT CLUTCH R55 M10
2	817789	YOKE W/ QL BALL TYPE
3	817791	INBOARD YOKE FOR INNERTUBE
4	817800	YOKE W/TUBE & SLEEVE
5	817793	CROSS KIT
6	817801	SPLINED TUBE
7	925360	ELASTIC PIN 10MM X 80MM
8	817802	SHAFT SHIELD
9	817774	CHAIN
10	817797	RETAINER
11	817798	RETAINER
-	817811	SHEAR BOLT KIT (F1695, F1696, F1732)
-	F1696	PTO SHAFT COMPLETE

### PTO Shaft Long - F1695

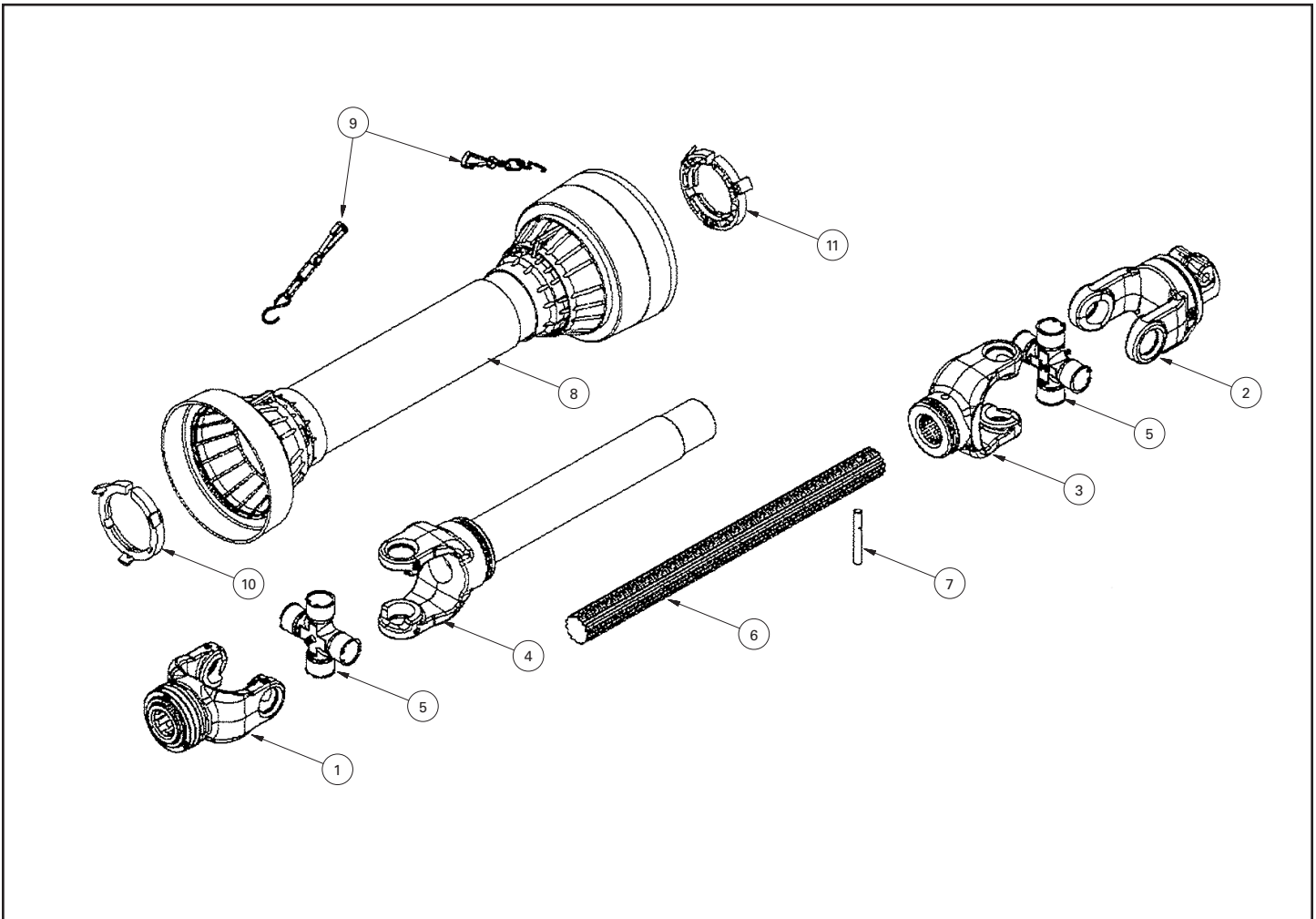

ITEM	PART NUMBER	DESCRIPTION
1	817789	YOKE W/ QL BALLTYPE
2	817790	SHEAR BOLT CLUTCH R55 M10
3	817791	INBOARDYOKE FOR INNER TUBE
4	817792	INBOARDYOKE W/TUBE & SLEEVE
5	817793	CROSS KIT
6	817794	SPLINED TUBE
7	925360	ELASTIC PIN 10MM X 80MM
8	817796	SHAFT SHIELD
9	817774	CHAIN
10	817797	RETAINER
11	817798	RETAINER
-	817811	SHEAR BOLT KIT (F1695, F1696, F1732)
-	F1695	PTO SHAFT LONG COMPLETE

## Hydraulic Spout Deflector Cylinder 1.75" x 5" (Option)

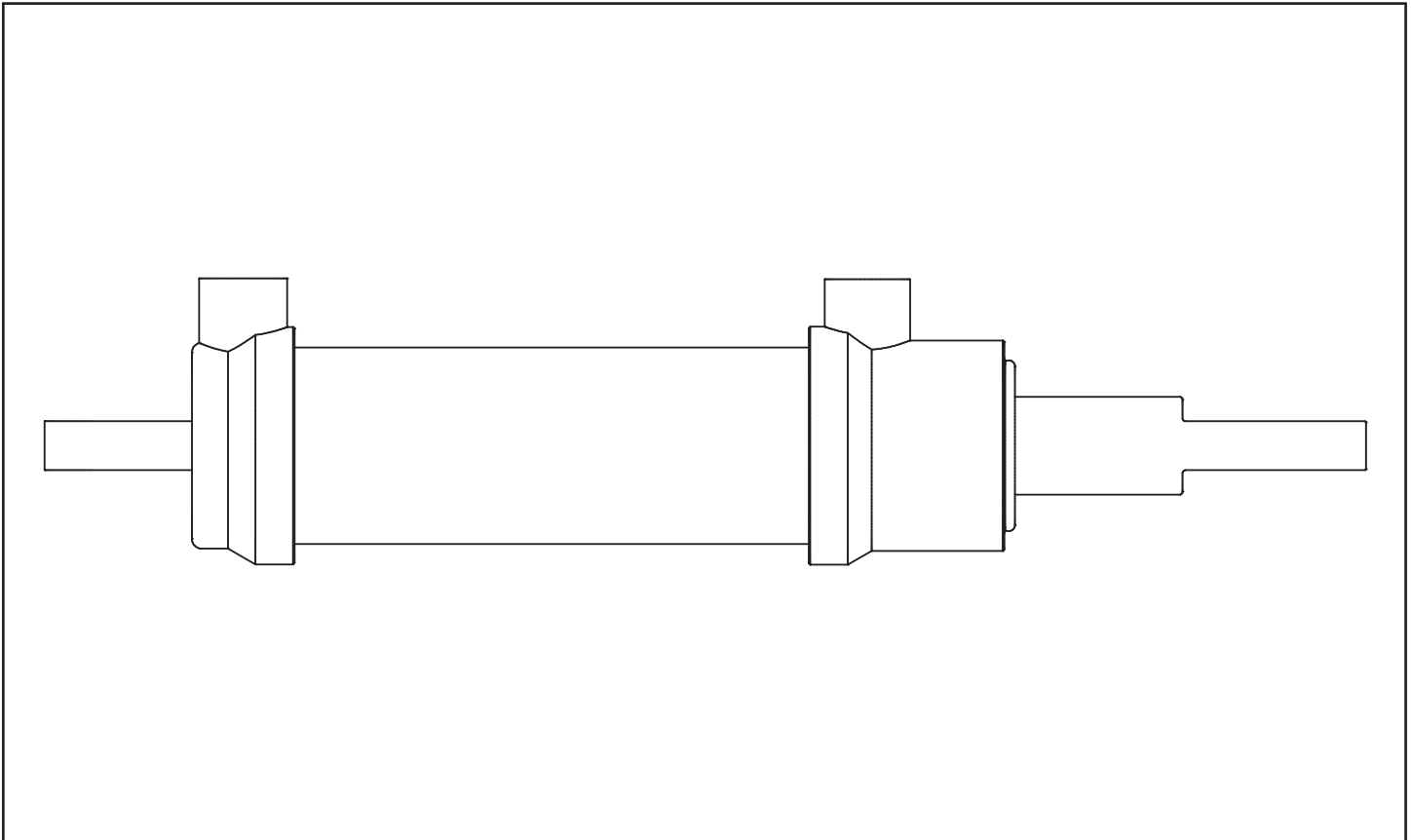

PART NUMBER	DESCRIPTION
24930M	1-3/4" ID X 5" STROKE CYLINDER
116983	HOSE 3/8 X 120 C/W FITTINGS
960913	CLEVIS PIN 1/2 X 1.8125 (PL)
9812430	COTTER PIN 1/8 X 1.00 (PL)
811918	ELBOW 90 9/16 SWMORB X 9/16 MJIC
24930M	CYLINDER COMPLETE
X3913	SEAL KIT
F9117	SPOUT DEFLECTOR CYLINDER & HOSE KIT

## Additional Components

THREE-POINT MOUNTING PINS

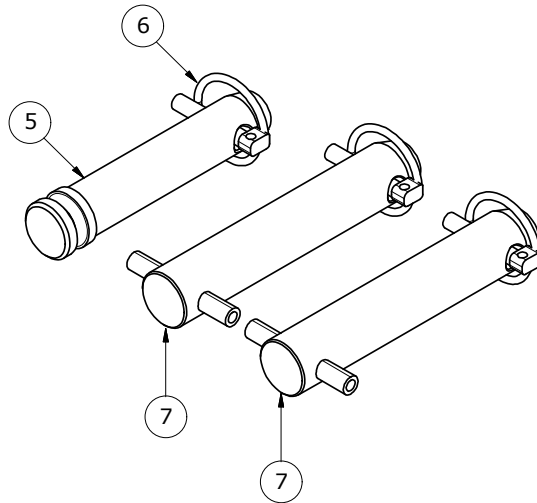

PTO ADDITIONAL HARDWARE

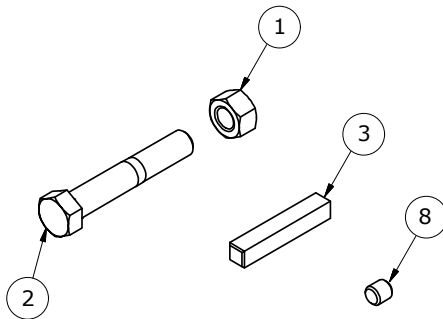

PTO SHIELD SPRING

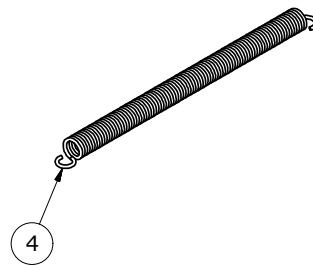

ITEM	PART NUMBER	DESCRIPTION	QTY.
1	812364	1/2" LOCK NUT (PL)	1
2	81627	1/2" X 3" HEX BOLT (PL)	1
3	911161	KEY 3/8"SQ. X 58mm	1
4	960135	PTO SHLD SPRG (#661)	1
5	965910	CAT 2 TOP LINK PIN	1
6	965911	LINCH PIN 7/16	3
7	965966	LIFT PIN CAT 2	2
8	988999	3/8"0 X 3/8" SOCKET SET SCREW (BR)	1

# Farm King





## Specifications And Shipping Kit Numbers

Specifications.....	67
Shipping Kit And Bundle Numbers Farm King.....	67
Shipping Kit And Bundle Numbers Allied.....	68
Hardware Torque Values.....	69
Metric Chart.....	69
Imperial Chart.....	70

# Farm King



## Specifications

MODEL	96"
Cutting Width	96"
Cutting Height	36"
Fan	4-Blade
Fan Diameter	32"
Drive Fan	540 rpm
Gearbox	Oil Bath Style
Auger Diameter	15" (Dual)
Auger Paddles (If Equipped)	20 (Per Auger)
Auger Drive	#60 Chain
Hydraulic Spout Rotator	STD.
Hydraulic Spout Deflector	OPT.
Skid Shoes	STD. Adjust.
Hitch Category	CAT. II / III
Hitch Adjustment	Fixed
Tractor Engine Requirements	90 - 125 HP
Weight	1243 lb.

**Note:** Dimensions are approximate measurements.

## Shipping Kit And Bundle Numbers Farm King

The following is a list of Kit Numbers for this product and the Bundle Numbers, Descriptions, and Quantities for each Kit.

Qty.	Bundle	Description
Y960Q-4 96" Farm King Snowblower - C/W double augers, hyd. chute control, oil bath gearbox, 4-blade fan		
1	F1526	Body Assembly
1	F1696	Standard PTO
1	X4008	Spout Turn Around Crate
Y960QL-4 96" Farm King Snowblower - C/W double augers, hyd. chute control, oil bath gearbox, 4-blade fan, 36" PTO		
1	F1526	Body Assembly
1	F1695	Long PTO
1	X4008	Spout Turn Around Crate
PR960Q-4 96" Farm King Snowblower - C/W double paddle augers, hyd. chute control, oil bath gearbox, 4-blade fan		
1	F1708	Body Assembly
1	F1696	Standard PTO
1	X4008	Spout Turn Around Crate
PR960QL-4 96" Farm King Snowblower - C/W double paddle augers, hyd. chute control, oil bath gearbox, 4-blade fan, 36" PTO		
1	F1708	Body Assembly
1	F1695	Long PTO
1	X4008	Spout Turn Around Crate
Optional Equipment		
1	F9117	Deflector Cylinder & Hose Kit
1	X3897	Cutting Edge

## Shipping Kit And Bundle Numbers Allied

The following is a list of Kit Numbers for this product and the Bundle Numbers, Descriptions, and Quantities for each Kit.

Qty.	Bundle	Description
YC9620Q-4 96" Allied Snowblower - C/W double augers, hyd. chute control, oil bath gearbox, 4-blade fan		
1	F1526A	Body Assembly
1	F1696	Standard PTO
1	X4008	Spout Turn Around Crate
YC9620QL-4 96" Allied Snowblower - C/W double augers, hyd. chute control, oil bath gearbox, 4-blade fan, 36" PTO		
1	F1526A	Body Assembly
1	F1695	Long PTO
1	X4008	Spout Turn Around Crate
PR9620Q-4 96" Allied Snowblower - C/W double paddle augers, hyd. chute control, oil bath gearbox, 4-blade fan		
1	F1708A	Body Assembly
1	F1696	Standard PTO
1	X4008	Spout Turn Around Crate
PR9620QL-4 96" Allied Snowblower - C/W double paddle augers, hyd. chute control, oil bath gearbox, 4-blade fan, 36" PTO		
1	F1708A	Body Assembly
1	F1695	Long PTO
1	X4008	Spout Turn Around Crate
Optional Equipment		
1	F9117	Deflector Cylinder & Hose Kit
1	X3897	Cutting Edge

# Hardware Torque Values

## Metric Chart

**NOTE: Do not use the values listed in the charts if a different torque value or tightening procedure is specified in this manual for a specific application. Torque values listed are for general use only.**

Use the following charts to determine the correct torque when checking, adjusting or replacing hardware. **Torque values are listed in newton-meters (inch\* or foot pounds) for normal assembly applications.**

Nominal Size	Class 5.8		Class 8.8		Class 10.9		Lock nuts
	Unplated	Plated W / ZnCr	Unplated	Plated W / ZnCr	Unplated	Plated W / ZnCr	CL.8 W/ CL. 8.8 Bolt
M4	1.7 (15*)	2.2 (19*)	2.6 (23*)	3.4 (30*)	3.7 (33*)	4.8 (42*)	1.8 (16*)
M6	5.8 (51*)	7.6 (67*)	8.9 (79*)	12 (102*)	13 (115*)	17 (150*)	6.3 (56*)
M8	14 (124*)	18 (159*)	22 (195*)	28 (248*)	31 (274*)	40 (354*)	15 (133*)
M10	28 (21)	36 (27)	43 (32)	56 (41)	61 (45)	79 (58)	30 (22)
M12	49 (36)	63 (46)	75 (55)	97 (72)	107 (79)	138 (102)	53 (39)
M16	121 (89)	158 (117)	186 (137)	240 (177)	266 (196)	344 (254)	131 (97)
M20	237 (175)	307 (226)	375 (277)	485 (358)	519 (383)	671 (495)	265 (195)
M24	411 (303)	531 (392)	648 (478)	839 (619)	897 (662)	1160 (855)	458 (338)

**NOTE: Torque values shown with \* are inch pounds.**

## Identification of Hex Cap Screws and Carriage Bolts - Classes 5 and up

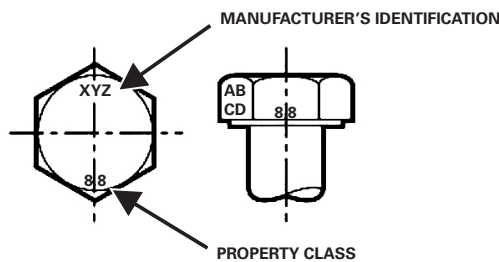

## Identification of Hex Nuts and Lock Nuts - Classes 5 and up

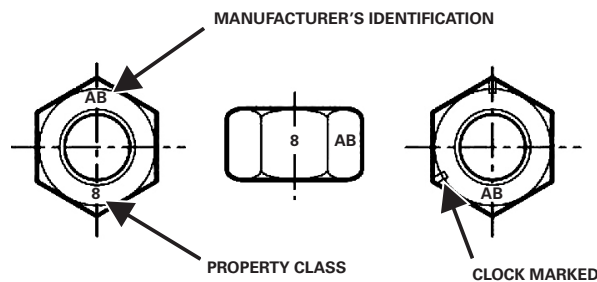

## Hardware Torque Values (Cont'd)

### Imperial Chart

**NOTE: Do not use the values listed in the charts if a different torque value or tightening procedure is specified in this manual for a specific application. Torque values listed are for general use only.**

Use the following charts to determine the correct torque when checking, adjusting or replacing hardware. Torque values are listed in newton-meters (inch\* or foot pounds) for normal assembly applications.

Nominal Size	SAE Grade 5		SAE Grade 8		LOCK NUTS			
	Unplated or Plated Silver	Plated W / ZnCr Gold"	Unplated or Plated Silver	Plated W / ZnCr Gold"	Unplated or Plated Silver	Plated W / ZnCr Gold"	Grade W / Gr. 5 Bolt	Grade W / Gr. 8 Bolt
1/4	6.2 (55*)	8.1 (72*)	9.7 (86*)	12.6 (112*)	13.6 (121*)	17.7 (157*)	6.9 (61*)	9.8 (86*)
5/16	13 (115*)	17 (149*)	20 (178*)	26 (229*)	28 (250*)	37 (324*)	14 (125*)	20 (176*)
3/8	23 (17)	30 (22)	35 (26)	46 (34)	50 (37)	65 (48)	26 (19)	35 (26)
7/16	37 (27)	47 (35)	57 (42)	73 (54)	80 (59)	104 (77)	41 (30)	57 (42)
1/2	57 (42)	73 (54)	87 (64)	113 (83)	123 (91)	159 (117)	61 (45)	88 (64)
9/16	81 (60)	104 (77)	125 (92)	163 (120)	176 (130)	229 (169)	88 (65)	125 (92)
5/8	112 (83)	145 (107)	174 (128)	224 (165)	244 (180)	316 (233)	122 (90)	172 (127)
3/4	198 (146)	256 (189)	306 (226)	397 (293)	432 (319)	560 (413)	217 (160)	306 (226)
7/8	193 (142)	248 (183)	495 (365)	641 (473)	698 (515)	904 (667)	350 (258)	494 (364)
1	289 (213)	373 (275)	742 (547)	960 (708)	1048 (773)	1356 (1000)	523 (386)	739 (545)

**NOTE: Torque values shown with \* are inch pounds.**

### Identification of Hex Cap Screws and Carriage Bolts



GRADE 2  
SAE BOLT



GRADE 5  
SAE BOLTS



GRADE 8  
SAE BOLTS



GRADE 2  
SAE NUTS



GRADE 5  
SAE NUTS



GRADE 8  
SAE NUTS

### Identification of Hex Nuts and Lock Nuts

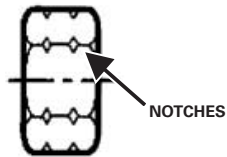

GRADE IDENTIFICATION

GRADE A: NO NOTCHES

GRADE B: ONE CIRCUMFERENTIAL NOTCH

GRADE C: TWO CIRCUMFERENTIAL NOTCHES

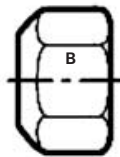

GRADE IDENTIFICATION

GRADE A: NO MARK

GRADE B: LETTER B

GRADE C: LETTER C

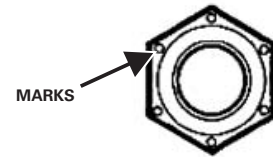

GRADE IDENTIFICATION

GRADE A: NO MARKS

GRADE B: THREE MARKS

GRADE C: SIX MARKS

MARKS NEED NOT BE LOCATED AT CORNERS

# Warranty

Farm King Base Limited Warranty.....	73
Repair Parts Limited Warranty.....	73
What Is Not Covered.....	73
Authorized Dealer And Labor Costs.....	73
Warranty Requirements.....	74
EXCLUSIVE EFFECT OF WARRANTY AND LIMITATION OF LIABILITY.....	74



# Farm King



## **Farm King Base Limited Warranty**

Farm King provides this warranty only to original retail purchasers of its products. Farm King warrants to such purchasers that all Farm King manufactured parts and components used and serviced as provided for in the Operator's Manual shall be free from defects in materials and workmanship for a period following delivery to the original retail purchaser of one (1) year. This limited warranty applies only to those parts and components manufactured by Farm King. Parts and components manufactured by others are subject to their manufacturer's warranties, if any.

Farm King will fulfill this limited warranty by, at its option, repairing or replacing any covered part that is defective or is the result of improper workmanship, provided that the part is returned to Farm King within thirty (30) days of the date that such defect or improper workmanship is, or should have been, discovered. Parts must be returned through the selling representative and the buyer must prepay transportation charges.

Farm King will not be responsible for repairs or replacements that are necessitated, in whole or part, by the use of parts not manufactured by or obtained from Farm King. Under no circumstances are component parts warranted against normal wear and tear. There is no warranty on product pump seals, product pump bearings, rubber product hoses, pressure gauges, or other components that require replacement as part of normal maintenance.

### **Repair Parts Limited Warranty**

Farm King warrants genuine Farm King replacement parts purchased after the expiration of the Farm King Limited Warranty, and used and serviced as provided for in the Operator's Manual, to be free from defects in materials or workmanship for a period of thirty (30) days from the invoice date for the parts. Farm King will fulfill this limited warranty by, at its option, repairing or replacing any covered part that is defective or is the result of improper workmanship, provided that the part is returned to Farm King within thirty (30) days of the date that such defect or improper workmanship is, or should have been, discovered. Such parts must be shipped to the Farm King factory at the purchaser's expense.

### **What Is Not Covered**

Under no circumstances does this limited warranty cover any components or parts that have been subject to the following: negligence; alteration or modification not approved by Farm King; misuse; improper storage; lack of reasonable and proper maintenance, service, or repair; normal wear; damage from failure to follow operating instructions; accident; and/or repairs that have been made with parts other than those manufactured, supplied, and or authorized by Farm King.

### **Authorized Dealer And Labor Costs**

Repairs eligible for labor under this limited warranty must be made by Farm King or an authorized Farm King dealer. Farm King retains the exclusive discretion to determine whether it will pay labor costs for warranty repairs or replacements, and the amount of such costs that it will pay and the time in which the repairs will be made. If Farm King determines that it will pay labor costs for warranty work, it will do so by issuing a credit to the dealer's or distributor's account. Farm King will not approve or pay invoices sent for repairs that Farm King has not previously approved. Warranty service does not extend the original term of this limited warranty.

## **Warranty Requirements**

To be covered by warranty, each new product must be registered with Farm King within thirty (30) days of delivery to original retail purchaser. If the customer decides to purchase replacement components before the warranty disposition of such components is determined, Farm King will bill the customer for such components and then credit the replacement invoice for those components later determined to be covered by this limited warranty. Any such replacement components that are determined not be covered by this limited warranty will be subject to the terms of the invoice and shall be paid for by the purchaser.

## **EXCLUSIVE EFFECT OF WARRANTY AND LIMITATION OF LIABILITY**

TO THE EXTENT PERMITTED BY LAW, FARM KING DISCLAIMS ANY WARRANTIES, REPRESENTATIONS, OR PROMISES, EXPRESS OR IMPLIED, AS TO THE QUALITY, PERFORMANCE, OR FREEDOM FROM DEFECT OF THE COMPONENTS AND PARTS COVERED BY THIS WARRANTY AND NOT SPECIFICALLY PROVIDED FOR HEREIN.

TO THE EXTENT PERMITTED BY LAW, FARM KING DISCLAIMS ANY IMPLIED WARRANTIES OF MERCHANTABILITY AND FITNESS FOR A PARTICULAR PURPOSE ON ITS PRODUCTS COVERED HEREIN, AND DISCLAIMS ANY RELIANCE BY THE PURCHASER ON FARM KING'S SKILL OR JUDGMENT TO SELECT OR FURNISH GOODS FOR ANY PARTICULAR PURPOSE. THE PURCHASER'S ONLY AND EXCLUSIVE REMEDIES IN CONNECTION WITH THE BREACH OR PERFORMANCE OF ANY WARRANTY ON FARM KING'S PRODUCTS ARE THOSE SET FORTH HEREIN. IN NO EVENT SHALL FARM KING BE LIABLE FOR INCIDENTAL OR CONSEQUENTIAL DAMAGES (INCLUDING, BY WAY OF EXAMPLE ONLY AND NOT LIMITATION, LOSS OF CROPS, LOSS OF PROFITS OR REVENUE, OTHER COMMERCIAL LOSSES, INCONVENIENCE, OR COST OF REPLACEMENT OF RENTAL EQUIPMENT). IN NO EVENT SHALL FARM KING'S CONTRACT OR WARRANTY LIABILITY EXCEED THE PURCHASE PRICE OF THE PRODUCT. (Note that some states do not allow limitations on how long an implied warranty lasts or the exclusion or limitation of incidental or consequential damages, so the above limitations and exclusion may not apply to you.) This warranty gives you specific legal rights and you may also have other rights, which vary from state to state.

Farm King neither assumes nor authorizes any person or entity, including its selling representatives, to assume any other obligations or liability in connections with the sale of covered equipment, or to make any other warranties, representations, or promises, express or implied, as to the quality, performance, or freedom from defect of the components and parts covered herein. No one is authorized to alter, modify, or enlarge this limited warranty, or its exclusions, limitations and reservations.

Corrections of defects and improper workmanship in the manner, and for the applicable time periods, provided for herein shall constitute fulfillment of all responsibilities of Farm King to the purchaser, and Farm King shall not be liable in negligence, contract, or on any other basis with respect to the subject equipment.

This limited warranty is subject to any existing conditions of supply which may directly affect Farm King's ability to obtain materials or manufacturer replacement parts.

Buhler Industries Inc. reserves the right to make improvements in design or changes in specifications to its products at anytime, without incurring any obligation to owners of units previously sold.



[www.farm-king.com](http://www.farm-king.com)

# Farm King

1330 43rd Street North  
Fargo, ND, 58102  
Toll Free: 877.447.6008  
E-mail: [info@buhler.com](mailto:info@buhler.com)  
[www.farm-king.com](http://www.farm-king.com)

Equipment shown is subject to change without notice.  
©2018 Buhler Trading Inc. Printed in USA TSX: BUI