

Farm King

OPERATOR AND PARTS MANUAL

Rotary Cutter

Model 820

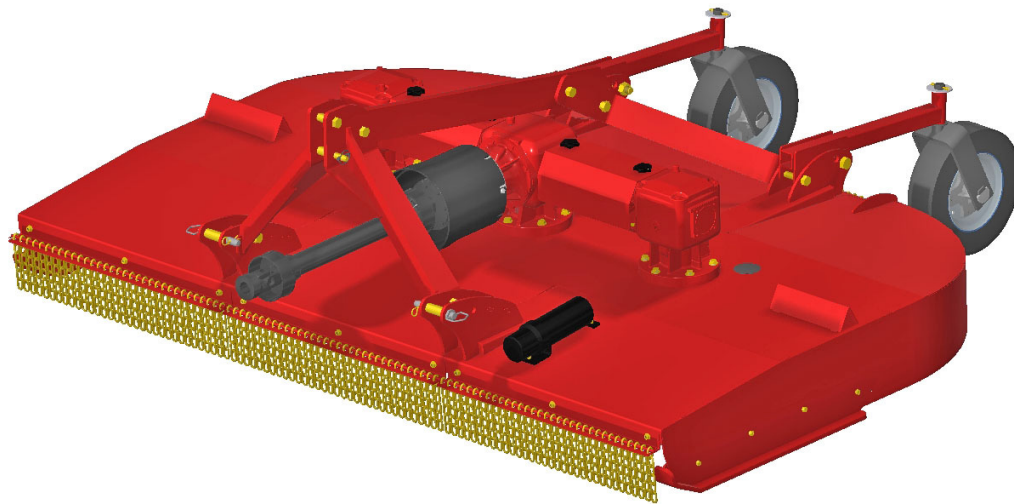

TABLE OF CONTENTS

Manufacturer’s Statement: For technical reasons, Buhler Industries Inc. reserves the right to modify machinery design and specifications provided herein without any preliminary notice. Information provided herein is of descriptive nature. Performance quality may depend on contour of ground, thickness of grass, weather conditions and other factors.

INTRODUCTION7

SAFETY13

ASSEMBLY27

OPERATION35

MAINTENANCE53

PARTS IDENTIFICATION69

SPECIFICATIONS91

WARRANTY99

ALPHABETICAL INDEX103

Farm King



WARRANTY REGISTRATION FORM

This form must be filled out by the dealer and signed by both the dealer and the customer at the time of delivery.

Customer Name:		Dealer Name:	
Customer Address:		Dealer Address:	
City:	Prov / State:	City:	Prov / State:
Postal / Zip Code:	Phone:	Postal / Zip Code:	Phone:

Equipment Name Model:	Serial Number:	Delivery Date:
-----------------------	----------------	----------------

I have thoroughly instructed the buyer on the above described equipment which review included the Operator’s Manual content, equipment care, adjustments, safe operation and applicable warranty policy.

Dealer Inspection Report

<input type="checkbox"/>	Gearbox Oil Level
<input type="checkbox"/>	Lubricate Machine
<input type="checkbox"/>	Wheel Bolt Torque
<input type="checkbox"/>	Fasteners Tight
<input type="checkbox"/>	Adjustment Link
<input type="checkbox"/>	Hydraulic Hoses
<input type="checkbox"/>	Electrical Harnesses (If Equipped)
<input type="checkbox"/>	Tire Pressure

Safety

<input type="checkbox"/>	All Lights And Reflectors Installed
<input type="checkbox"/>	All Lights And Reflectors Cleaned And Working
<input type="checkbox"/>	Safety Chain On Hitch
<input type="checkbox"/>	All Decals Installed
<input type="checkbox"/>	Guards And Shields Installed And Secure
<input type="checkbox"/>	Review Operating And Safety Instructions
<input type="checkbox"/>	General Adjustment And Set-up Procedures
<input type="checkbox"/>	Transportation Requirements And Regulations

Date:	Dealer Rep. Signature:
-------	------------------------

The above equipment and Operator And Parts Manual have been received by me and I have been thoroughly instructed as to care, adjustments, safe operation and applicable warranty policy.

Date:	Customer / Owner’s Signature:
-------	-------------------------------

Remove this Warranty Registration Form from the Operator And Parts Manual. Make two copies of the form. Send original Warranty Registration Form to Farm King. Give one copy to the customer and the dealer will keep one copy.

Farm King



INTRODUCTION

This Operator And Parts Manual was written to give the owner / operator instructions on the safe operation, maintenance and part identification of the Farm King equipment. **READ AND UNDERSTAND THIS OPERATOR AND PARTS MANUAL BEFORE OPERATING YOUR FARM KING EQUIPMENT.** If you have any questions, see your Farm King dealer. This manual may illustrate options and accessories not installed on your Farm King equipment.

OWNER'S INFORMATION9
 Serial Number Location9
 Manual Storage9

EQUIPMENT IDENTIFICATION10
 3-Point Component Location10
 Pull Type Component Location11

Farm King



OWNER’S INFORMATION

Thank you for your decision to purchase a Farm King Rotary Cutter. To ensure maximum performance of your equipment, it is mandatory that you thoroughly study the Operator And Parts Manual and follow the recommendations. Proper operation and maintenance are essential to maximize equipment life and prevent personal injury.

Operate and maintain this equipment in a safe manner and in accordance with all applicable local, state, and federal codes, regulations and / or laws. Follow all on-product labeling and instructions.

Make sure that all personnel have read this Operator and Parts Manual and thoroughly understand safe and correct operating, installation and maintenance procedures.

Farm King is continually working to improve its products. Farm King reserves the right to make any improvements or changes as deemed practical and possible without incurring any responsibility or obligation to make any changes or additions to equipment sold previously.

Although great care has been taken to ensure the accuracy of this publication, Farm King makes no warranty or guarantee of any kind, written or expressed, implied or otherwise with regard to the information contained within this manual. Farm King assumes no responsibility for any errors that may appear in this manual and shall not be liable under any circumstances for incidental, consequential or punitive damages in connection with, or arising from the use of this manual.

Keep this manual available for frequent reference. All new operators or owners must review the manual before using the equipment and annually thereafter. Contact your Farm King Dealer if you need assistance, information, or additional copies of the manual. Visit our website at www.farm-king.com for a complete list of dealers in your area.

The directions left, right, front and rear, as mentioned throughout this manual, are as viewed from the rear of the equipment.

Serial Number Location

Please enter the model and serial number in the space provided for easy reference.

Figure 1

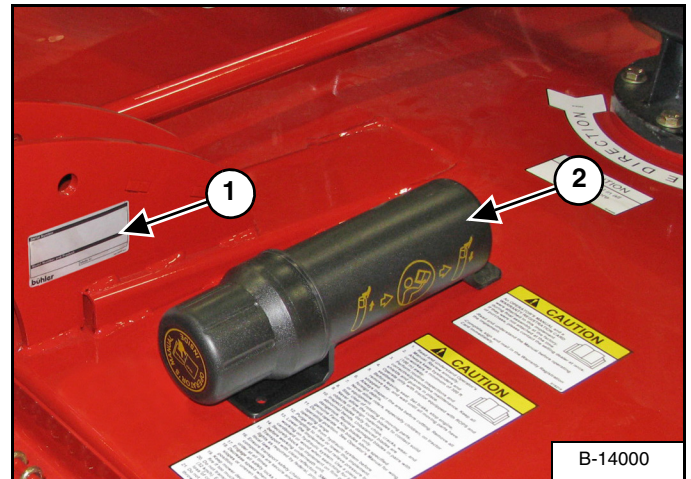

Model Number: _____

Serial Number: _____

The serial number plate (Item 1) [Figure 1] is located on the inside of the left hitch mounting plate.

Always use your serial number when requesting information or when ordering parts.

Manual Storage

The Operator And Parts Manual and other documents can be stored in the canister (Item 2) [Figure 1] located on the deck.

EQUIPMENT IDENTIFICATION

3-Point Component Location

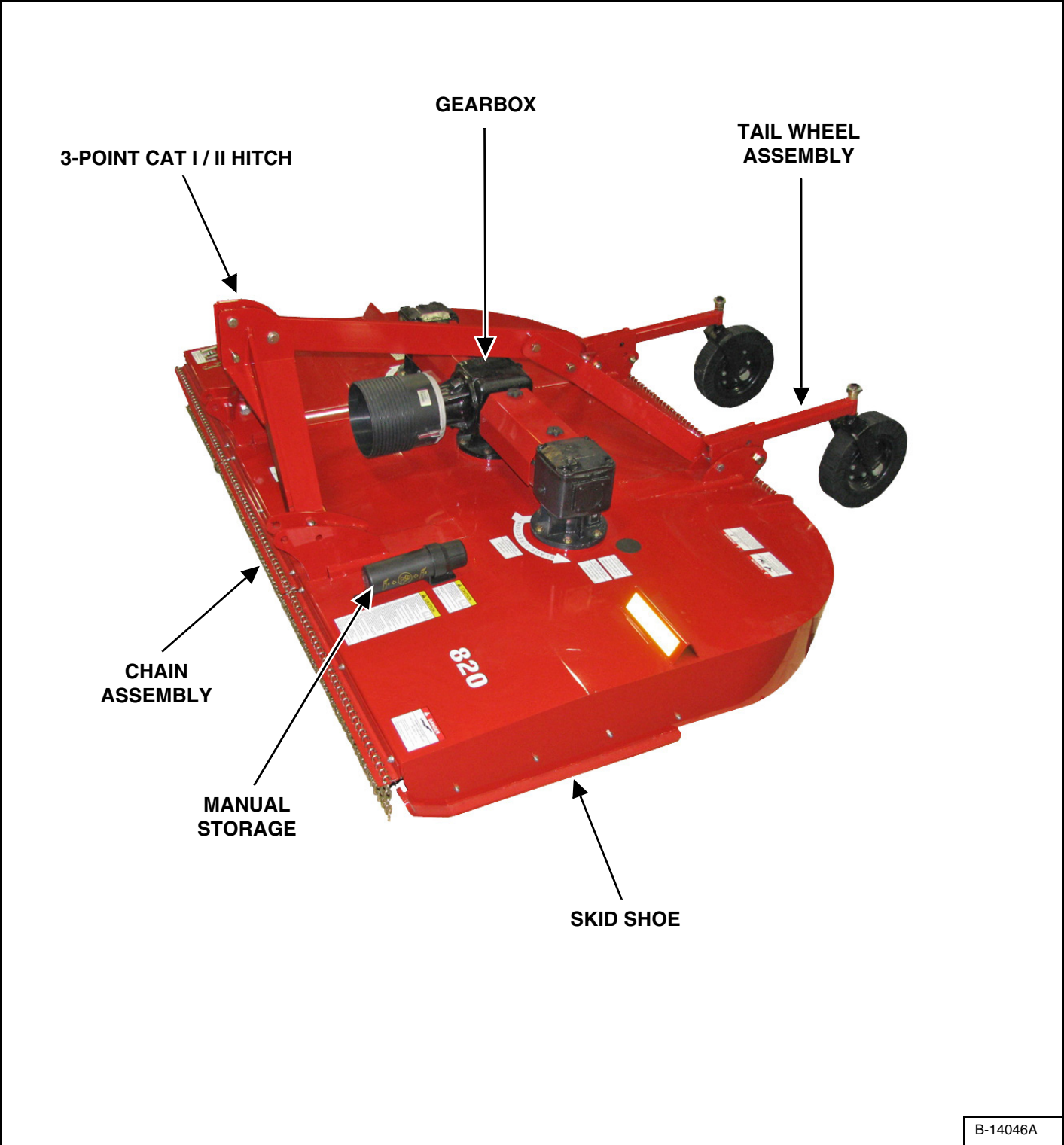

Pull Type Component Location

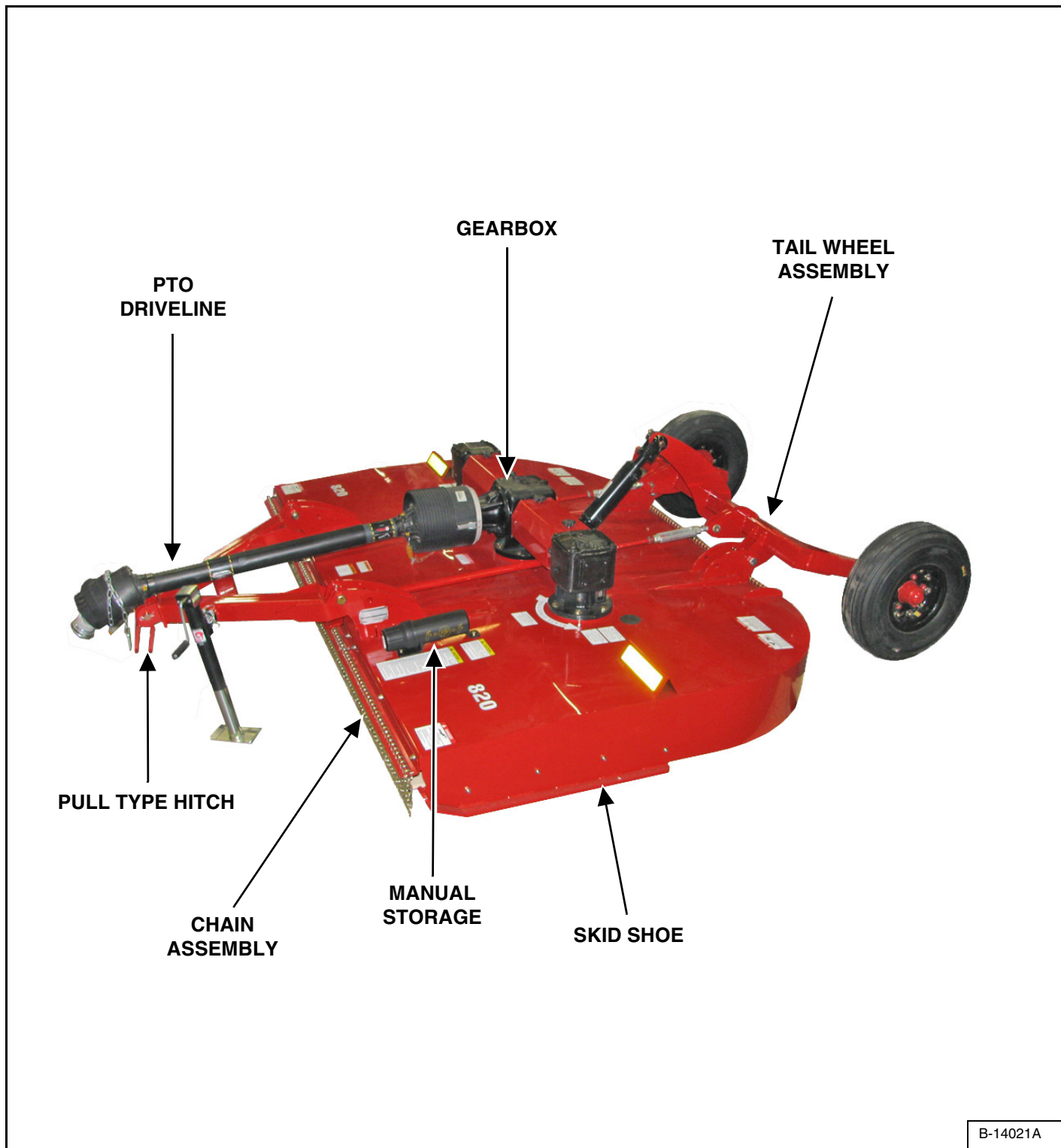

Farm King



SAFETY

SAFETY INSTRUCTIONS 15

- Safe Operation Is The Operator’s Responsibility 15
- Safe Operation Needs A Qualified Operator 15
- Use Safety Rules 16
- Transport Safety 16
- Safety Rules For Power Take-Off (PTO) Driven Equipment 17
- Machine Requirements And Capabilities 17

FIRE PREVENTION 18

- Maintenance 18
- Operation 18
- Starting 18
- Electrical 18
- Hydraulic System 18
- Fueling 18
- Spark Arrester Exhaust System 18
- Welding And Grinding 19
- Fire Extinguishers 19

SAFETY SIGNS (DECALS) 20

EQUIPMENT DECALS AND SIGNS 25

SAFETY SIGN-OFF FORM 26

Farm King



SAFETY INSTRUCTIONS

Safe Operation Is The Operator’s Responsibility

	<p>Safety Alert Symbol</p>
<p>This symbol with a warning statement means: “Warning, be alert! Your safety is involved!” Carefully read the message that follows.</p>	



CAUTION

The signal word **CAUTION** on the machine and in the manuals indicates a potentially hazardous situation which, if not avoided, may result in minor or moderate injury. It may also be used to alert against unsafe practices.



DANGER

The signal word **DANGER** on the machine and in the manuals indicates a hazardous situation which, if not avoided, will result in death or serious injury.



WARNING

The signal word **WARNING** on the machine and in the manuals indicates a potentially hazardous situation which, if not avoided, could result in death or serious injury.



IMPORTANT

This notice identifies procedures which must be followed to avoid damage to the machine.

Safe Operation Needs A Qualified Operator



WARNING

Operators must have instructions before operating the machine. Untrained operators can cause injury or death.

For an operator to be qualified, he or she must not use drugs or alcoholic drinks which impair alertness or coordination while working. An operator who is taking prescription drugs must get medical advice to determine if he or she can safely operate a machine and the equipment.

A Qualified Operator Must Do The Following:

Understand the Written Instructions, Rules and Regulations

- The written instructions from Farm King include the Warranty Registration, Dealer Inspection Report, Operator And Parts Manual and machine signs (decals).
- Check the rules and regulations at your location. The rules may include an employer’s work safety requirements. Regulations may apply to local driving requirements or use of a Slow Moving Vehicle (SMV) emblem. Regulations may identify a hazard such as a utility line.

Have Training with Actual Operation

- Operator training must consist of a demonstration and verbal instruction. This training is given by the machine owner prior to operation.
- The new operator must start in an area without bystanders and use all the controls until he or she can operate the machine safely under all conditions of the work area. Always fasten seat belt before operating.

Know the Work Conditions

- Clear working area of all bystanders, especially small children and all obstacles that might be hooked or snagged, causing injury or damage.
- Know the location of any overhead or underground power lines. Call local utilities and have all underground power lines marked prior to operation.
- Wear tight fitting clothing. Always wear safety glasses when doing maintenance or service.

SAFETY INSTRUCTIONS (CONT'D)**Use Safety Rules**

- Read and follow instructions in this manual and the tractor's Operators Manual before operating.
- Under no circumstances should young children be allowed to work with this equipment.
- This equipment is dangerous to children and persons unfamiliar with its operation.
- If the elderly are assisting with work, their physical limitations need to be recognized and accommodated.
- Check for overhead and / or underground lines before operating equipment (if applicable).
- In addition to the design and configuration of equipment, hazard control and accident prevention are dependent upon the awareness, concern, prudence and proper training of personnel involved in the operation, transport, maintenance and storage of equipment.
- Check that the equipment is securely fastened to the tractor / towing vehicle.
- Make sure all the machine controls are in the NEUTRAL position before starting the machine.
- Operate the equipment only from the operator's position.
- Operate the equipment according to the Operator And Parts Manual.
- When learning to operate the equipment, do it at a slow rate in an area clear of bystanders, especially small children.
- DO NOT permit personnel to be in the work area when operating the equipment.
- The equipment must be used ONLY on approved tractors / transport vehicles.
- DO NOT modify the equipment in any way. Unauthorized modification may impair the function and / or safety and could affect the life of the equipment.
- DO NOT make any adjustments or repairs on the equipment while the machine is running.
- Keep shields and guards in place. Replace if damaged.
- Operate only with tractor equipped with ROPS (Roll Over Protective System) and seatbelts.

- DO NOT operate rotary cutter in poor visibility conditions such as fog, darkness, or any conditions that limit clear visibility less than 300 feet (100 m) in front of and to the sides of the rotary cutter.
- When conditions make it necessary to slow ground speed, shift to a lower gear rather than reducing engine speed. The engine will maintain rated speed and keep cutter running at optimum cutting speed.
- DO NOT operate in a work area that has not been inspected for foreign debris and obstacles.
- Remove any foreign objects and clearly mark any objects that cannot be removed.

Transport Safety

- Do not exceed 20 mph (32 kph). Reduce speed on rough roads and surfaces.
- Comply with state and local laws governing highway safety and movement of machinery on public roads.
- The use of flashing amber lights is acceptable in most localities. However, some localities prohibit their use. Local laws should be checked for all highway lighting and marking requirements.
- Always install transport locks, pins or brackets before transporting (if applicable).
- Always yield to oncoming traffic in all situations and move to the side of the road so any following traffic may pass.
- Always enter curves or drive up or down hills at a low speed and at a gradual steering angle.
- Never allow riders on either tractor or equipment.
- Keep tractor / towing vehicle in a lower gear at all times when traveling down steep grades.
- Maintain proper brake settings at all times (if equipped).

Safety Rules For Power Take-Off (PTO) Driven Equipment

- Keep PTO shields and all guards in place. Replace damaged or missing shields and guards before operating.
- Follow warnings and instructions on machine signs (decals). Replace damaged or missing decals.
- Do not wear loose or bulky clothing around the PTO or other moving parts.
- Keep bystanders away from PTO driven equipment, and never allow children near machines.
- Read and understand the manuals for the PTO driven equipment and be aware of safe operating procedures and hazards that may not be readily apparent.
- Always walk around equipment to avoid coming near a turning PTO driveline. Stepping over, leaning across or crawling under a turning PTO driveline can cause entanglement.
- Position the machine and equipment hitch correctly to prevent driveline stress and separation.
- Use caution when turning. Turning too sharp can cause driveline damage.
- Use caution when raising PTO driven attachment. Excessive driveline angle can cause driveline damage. Use stops if needed.
- Use increased caution on slopes and near banks and ditches to prevent overturn.
- Make certain that the Slow Moving Vehicle (SMV) emblem is installed so that it is visible and legible. When transporting the equipment, use the flashing warning lights (if equipped) and follow all local regulations.
- Operate this equipment with a machine equipped with an approved Roll-Over Protective Structure (ROPS). Always wear seat belt when the ROPS is up. Serious injury or death could result from falling off the machine.
- Before leaving the operator's position:
 1. Always park on a flat level surface.
 2. Place all controls in neutral.
 3. Engage the parking brake.
 4. Stop engine.
 5. Wait for all moving parts to stop.
- Carry passengers only in designated seating areas. Never allow riders on the machine or equipment. Falling off can result in serious injury or death.
- Start the equipment only when properly seated in the operator's seat. Starting a machine in gear can result in serious injury or death.
- Operate the machine and equipment from the operator's position only.
- The parking brake must be engaged before leaving the operator's seat. Rollaway can occur because the transmission may not prevent machine movement.

Machine Requirements And Capabilities

- Fasten seat belt securely. If equipped with a foldable Roll-Over Protective Structure (ROPS), only fasten seat belt when ROPS is up and locked. DO NOT wear seat belt if ROPS is down.
- Machine's three-point hitch must be equipped with sway bars or chains.
- Stop the machine and engage the parking brake. Install blocks in front of and behind the rear tires of the machine. Install blocks underneath and support the equipment securely before working under raised equipment.
- Keep bystanders clear of moving parts and the work area. Keep children away.

FIRE PREVENTION



Maintenance

The machine and some equipment have components that are at high temperatures under normal operating conditions. The primary source of high temperatures is the engine and exhaust system. The electrical system, if damaged or incorrectly maintained, can be a source of arcs or sparks.

Flammable debris (leaves, straw, etc.) must be removed regularly. If flammable debris is allowed to accumulate, it can cause a fire hazard. Clean often to avoid this accumulation. Flammable debris in the engine compartment is a potential fire hazard.

The operator's area, engine compartment and engine cooling system must be inspected every day and cleaned if necessary to prevent fire hazards and overheating.

All fuels, most lubricants and some coolant mixtures are flammable. Flammable fluids that are leaking or spilled onto hot surfaces or onto electrical components can cause a fire.

Operation

The Farm King machine must be in good operating condition before use.

Check all of the items listed on the service schedule under the 8 hour column. (See "SERVICE SCHEDULE" on page 57.)

Do not use the machine where exhaust, arcs, sparks or hot components can contact flammable material, explosive dust or gases.

Starting

Do not use ether or starting fluids on any engine that has glow plugs. These starting aids can cause explosion and injure you or bystanders.

Use the procedure in the tractor's operator's manual for connecting the battery and for jump starting.

Electrical



Check all electrical wiring and connections for damage. Keep the battery terminals clean and tight. Repair or replace any damaged part or wires that are loose or frayed.

Battery gas can explode and cause serious injury. Do not jump start or charge a frozen or damaged battery. Keep any open flames or sparks away from batteries. Do not smoke in battery charging area.

Hydraulic System

Check hydraulic tubes, hoses and fittings for damage and leakage. Never use open flame or bare skin to check for leaks. Hydraulic tubes and hoses must be properly routed and have adequate support and secure clamps. Tighten or replace any parts that show leakage.

Always clean fluid spills. Do not use gasoline or diesel fuel for cleaning parts. Use commercial nonflammable solvents.

Fueling



Stop the engine and let it cool before adding fuel. No smoking! Do not refuel a machine near open flames or sparks. Fill the fuel tank outdoors.

Spark Arrester Exhaust System

The spark arrester exhaust system is designed to control the emission of hot particles from the engine and exhaust system, but the muffler and the exhaust gases are still hot.

Check the spark arrester exhaust system regularly to make sure it is maintained and working properly. Use the procedure in the machine's Operator's Manual for cleaning the spark arrester muffler (if equipped).

FIRE PREVENTION (CONT'D)**Welding And Grinding**

Always clean the machine and equipment, disconnect the battery, and disconnect the wiring from the machine controls before welding. Cover rubber hoses, battery and all other flammable parts. Keep a fire extinguisher near the machine when welding.

Have good ventilation when grinding or welding painted parts. Wear dust mask when grinding painted parts. Toxic dust or gas can be produced.

Dust generated from repairing nonmetallic parts such as hoods, fenders or covers can be flammable or explosive. Repair such components in a well ventilated area away from open flames or sparks.

Fire Extinguishers

Know where fire extinguishers and first aid kits are located and how to use them. Inspect the fire extinguisher and service the fire extinguisher regularly. Obey the recommendations on the instructions plate.

SAFETY SIGNS (DECALS)

Follow the instructions on all the Signs (Decals) that are on the equipment. Replace any damaged signs (decals) and be sure they are in the correct locations. Equipment signs are available from your Farm King equipment dealer.

Left Rear Corner Of Deck



Right Rear Corner Of Deck



①



p/n 919272

②



p/n 918276

Left Front Corner Of Deck



1

CAUTION

1. Read and understand Operator's Manual. Review annually.
2. Always keep bystanders and co-workers a minimum of 300 ft (100 m) away.
3. Perform routine inspections and corrective/preventative maintenance. Keep all shields and guards in place.
4. Operate only with tractor equipped with ROPS and seatbelts.
5. Before leaving seat: Set brake, stop engine, remove key, and wait until all moving parts have stopped.
6. Always inspect the area before cutting. Remove all foreign debris.
7. Never allow riders, especially children, on tractor or equipment.
8. Stay clear of rotating or moving parts.
9. Never allow the cutter blades to contact solid objects or foreign materials.
10. Inspect blades daily for chips, cracks, wear, and abnormal bends. Unbalanced blades are dangerous. Replace damaged blades in pairs with genuine Farm King blades only.
11. Do not operate with wings above specified operating position. See Operator's Manual for wing operating range.
12. Purge all air from hydraulic system before attempting to raise or lower this implement.
13. Lower the implement and relieve pressure before working on hydraulic system. Use a piece of cardboard or wood when searching for leaks.
14. Securely block up implement on firm ground before working beneath unit.
15. Transport with clean reflectors, SMV, and working lights as required by federal, provincial/state, and local laws.
16. Ensure transport safety chain and all hitch components are secure and in proper working order at all times.
17. Engage all safety locks before transporting.
18. Decrease speed when turning, be careful on slopes or uneven terrain with wings in raised position.
19. Keep mower deck clear of debris. There is a risk of fire if too much debris accumulates.
20. Do not transport above speeds of 20 mph (32 km/h). Exceeding these speeds may result in loss of control.
21. Do not operate in raised position. Objects may be thrown under guards.

918283

2

CAUTION

An OPERATOR'S MANUAL and a WARRANTY REGISTRATION CARD were attached to this implement during final assembly at the factory. If they were not attached at the time of purchase, please contact the selling dealer at once.



- Read and understand the Manual before operating the implement.
- Complete, sign and mail in the Warranty Registration Card immediately.

919219

p/n 919219

3

DANGER



DAMAGED BLADES CAN CAUSE SERIOUS INJURY OR DEATH

- Inspect blades daily for chips, cracks, wear and abnormal bends.
- Replace blades with genuine Farm King blades only.
- Unbalanced blades are dangerous. Replace blades in pairs.

918277

p/n 918277

p/n 918283

Right Front Corner Deck



1

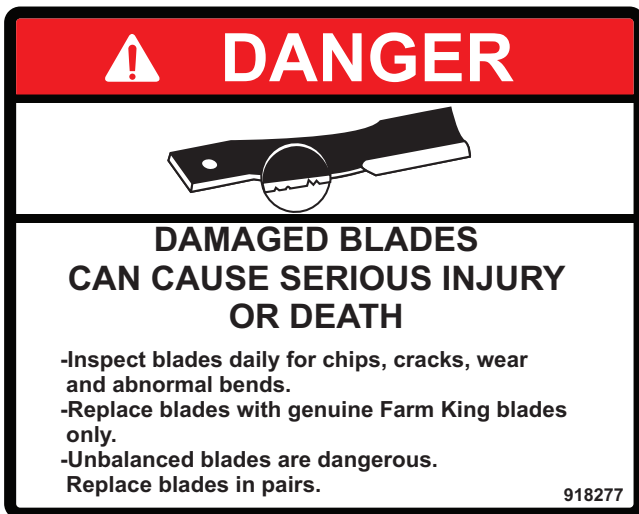

p/n 918277

Front Center Of Deck



1



p/n 918281

2



p/n 108431

3



p/n 918280

Under Gearbox Guard / Shield

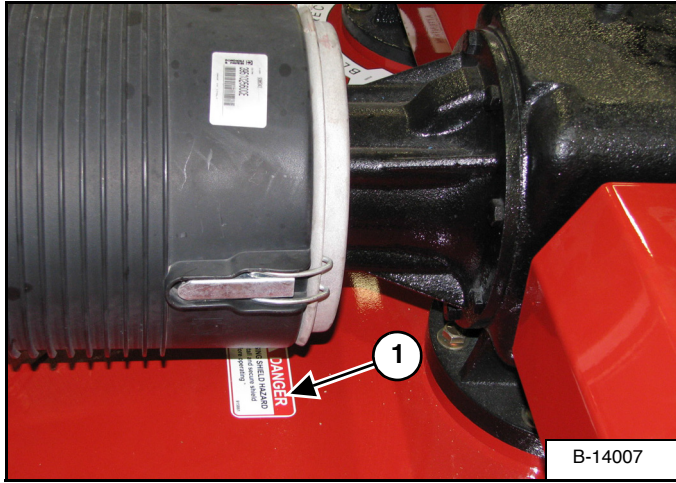

1

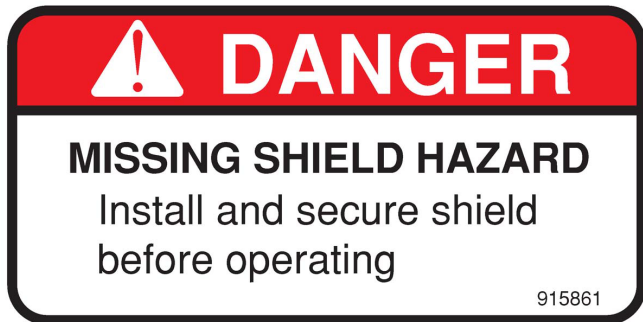

p/n 915861

Under Splitter Gearbox Guard / Shield

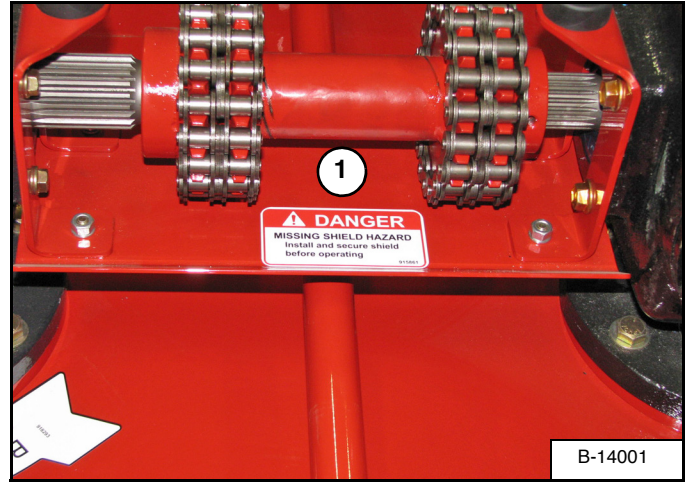

1



p/n 915861

EQUIPMENT DECALS AND SIGNS

NOTE: All safety related decals are shown in the Safety Signs Section. (See "SAFETY SIGNS (DECALS)" on page 20.)

Check and replace any worn, torn, hard to read or missing decals on your equipment.

Part Number 918297



Part Number 918298

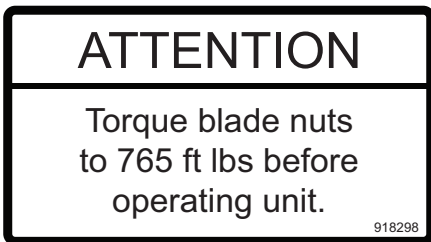

Part Number 918406

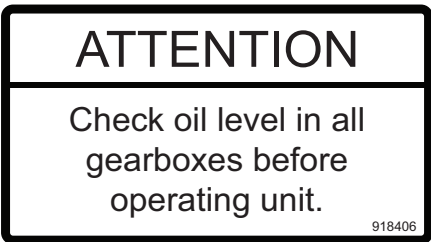

Part Number 967055 (Amber)

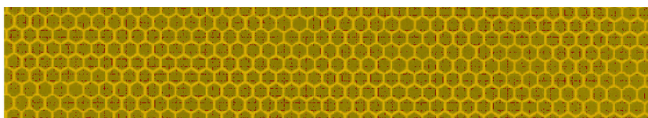

Part Number 967053 (Red)

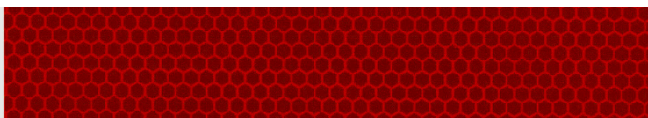

Part Number 918292

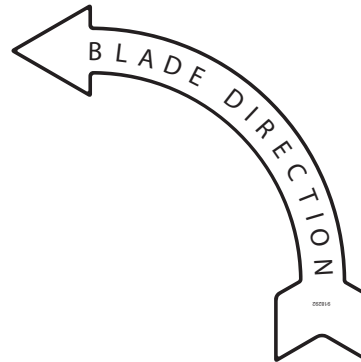

Part Number 918293

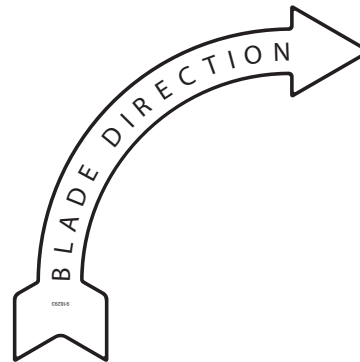

SAFETY SIGN-OFF FORM



Instructions are necessary before operating or servicing equipment. Read and understand the Operator And Parts Manual and safety signs (decals) on equipment. Follow warnings and instructions in the manuals when making repairs, adjustments or servicing. Check for correct function after adjustments, repairs or service. Untrained operators and failure to follow instructions can cause injury or death.

Farm King follows the general Safety Standards specified by the American Society of Agricultural and Biological Engineers (ASABE) and the Occupational Safety and Health Administration (OSHA). Anyone who will be operating and / or maintaining the 820 Rotary Cutter must read and clearly understand ALL Safety, Operating and Maintenance information presented in this manual.

Annually review this information before the season start-up and make these periodic reviews of SAFETY and OPERATION a standard practice for all of your equipment. An untrained operator is unqualified to operate this machine.

The following sign-off sheet is provided for your record and to show that all personnel who will be working with the equipment have read and understand the information in this Operator And Parts Manual and have been instructed in the operation of the equipment.

Table with 3 columns: Date, Employee's Signature, Employer's Signature. Title: SIGN-OFF SHEET

ASSEMBLY

3-POINT HITCH MOUNTED29
 Assembly Instructions29

TRAILING MODEL31
 Assembly Instructions31

Farm King



3-POINT HITCH MOUNTED

Assembly Instructions

Figure 2

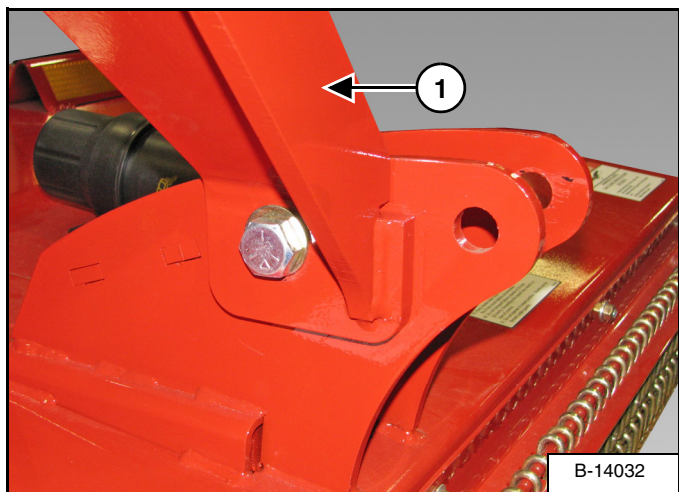

Locate the LHS top link mount weldment (Item 1) [Figure 2]. Align the LHS top link mount weldment with the mounting bracket on the front / left center of the deck.

Install one 3/4" flat washer onto a 3/4" x 2" bolt, then install one bottom link bushing on the bolt. Install the bolt assembly through the LHS top link mount weldment and mounting bracket. Install a 3/4" lock nut onto the bolt.

Repeat procedure for RHS top link mount weldment.

Figure 3

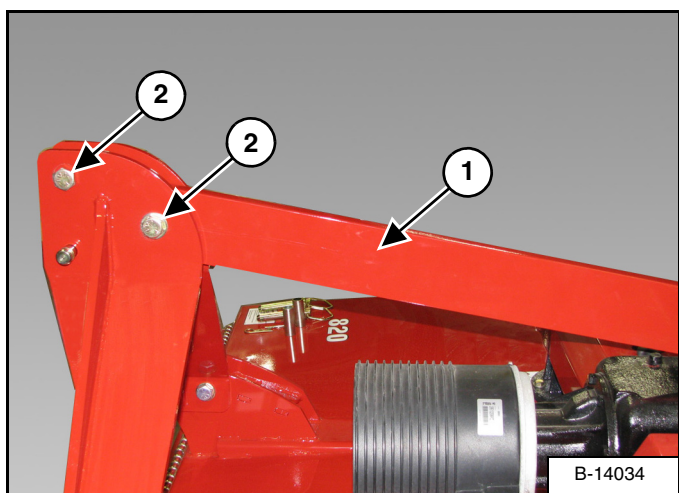

Locate the top hitch brace plate (Item 1) [Figure 3]. Align the top hitch brace plate with the lower rear hole on the LHS & RHS top link mount weldments.

Install the top link bushing onto a 3/4" x 5" bolt, then install the bolt assembly (Item 2) [Figure 3] through the LHS top link mount weldment, top hitch brace plate and RHS top link mount weldment. Install one 3/4" lock nut on the bolt.

Place the one 1" x 2" bushing between the LHS & RHS top link mount weldment, install a 3/4" x 4" bolt through the LHS top link mount weldment, bushing and RHS top link mount weldment. Install one 3/4" lock nut on the bolt.

Figure 4

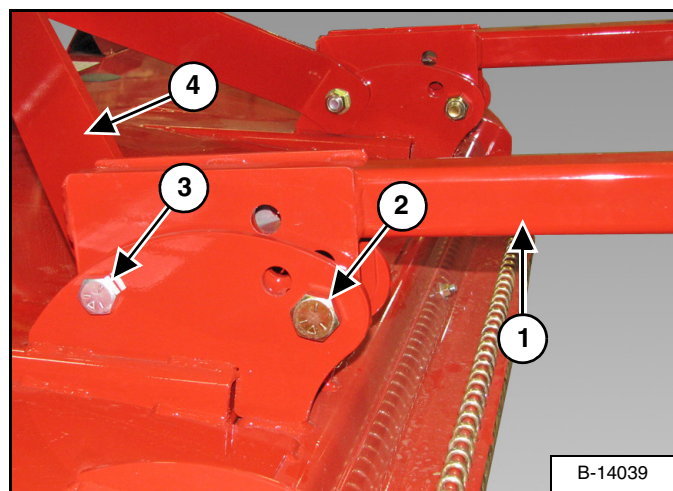

Locate the wheel assembly (Item 1) [Figure 4]. Align the wheel assembly with the mounting brackets on the rear of the deck.

Install one 7/64" W x 1-1/18" x 2-7/8" pin sleeve on a 7/8" x 5" bolt. Install the bolt assembly (Item 2) [Figure 4] through the mounting bracket and wheel assembly (both sides). Install one 7/8" lock nut on the bolt.

Install one 7/64" W x 1-1/18" x 2-7/8" pin sleeve on a 7/8" x 5" bolt. Install the bolt assembly (Item 3) [Figure 4] through the mounting bracket and wheel assembly (both sides).

Locate the two rear hitch brace plates (Item 4). Install one rear hitch brace plate over the front 7/8" x 5" bolt (Item 3) [Figure 4]. Install one 7/8" lock nut on the bolt (both sides).

Figure 5

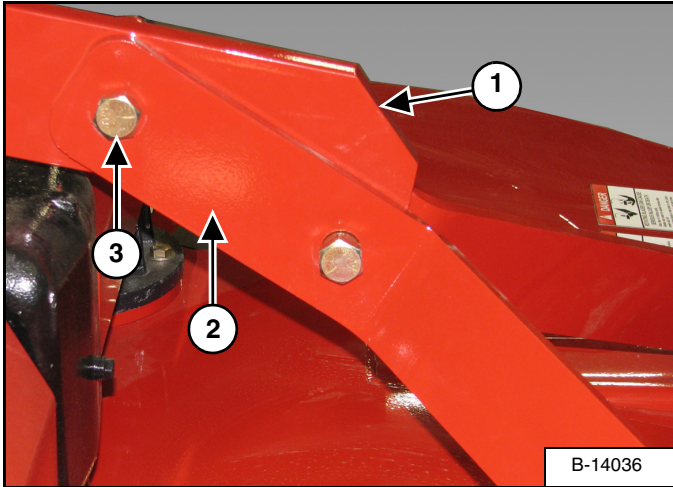

Align the top hitch brace plate (Item 1) and left rear hitch brace plate (Item 2) [Figure 5].

Install one 1" x 0.782" bushing on a 3/4" x 3-1/2" bolt. Install the bolt assembly (Item 3) [Figure 5] through the left rear hitch brace plate and top hitch brace plate. Place the right rear hitch brace plate on the open end of the bolt. Install one 3/4" lock nut on the bolt.

Figure 6

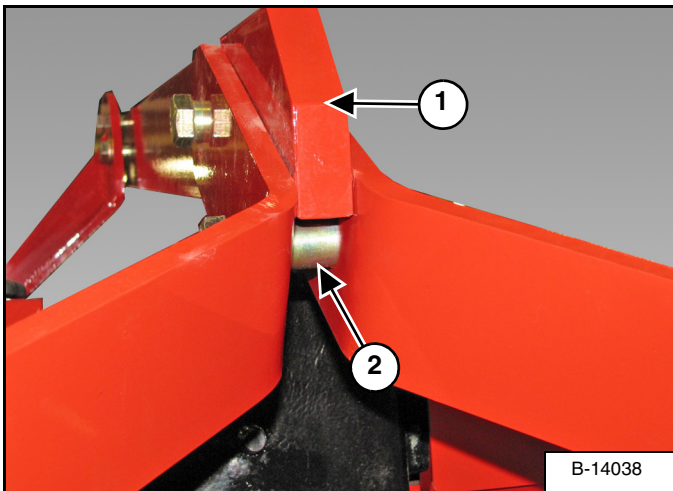

Install one 1" x 0.782" bushing on a 3/4" x 3-1/2" bolt. Move the top hitch brace plate (Item 1) above the rear holes of the left / right rear hitch brace plates. Install the bolt assembly (Item 2) [Figure 6] through the left rear hitch brace plate and right rear hitch brace plate. Install one 3/4" lock nut on the bolt.

Tighten all bolts and lock nuts.

Figure 7

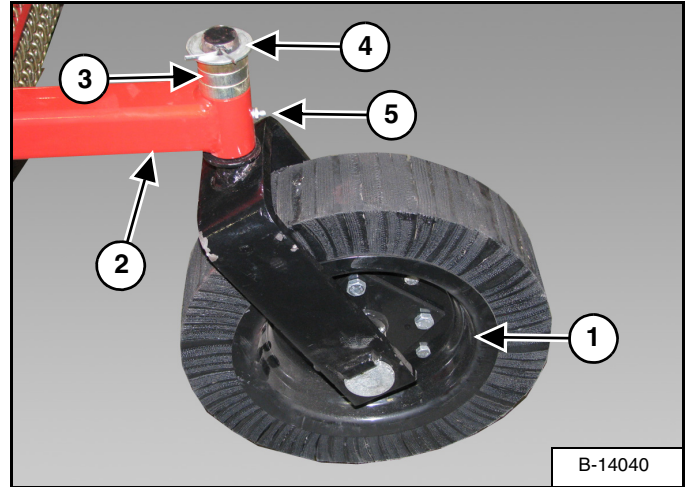

Install one wheel assembly (Item 1) up through the wheel arm weldment (Item 2) [Figure 7].

Install the tail wheel spacers (Item 3) onto the shaft. Install one 1-1/4" washer (Item 4) [Figure 7] onto the shaft and secure the wheel assembly to the wheel arm weldment using a 1/4" x 2" cotter pin

Install grease zerk (Item 5) [Figure 7].

Repeat for remaining wheel assembly.

Figure 8

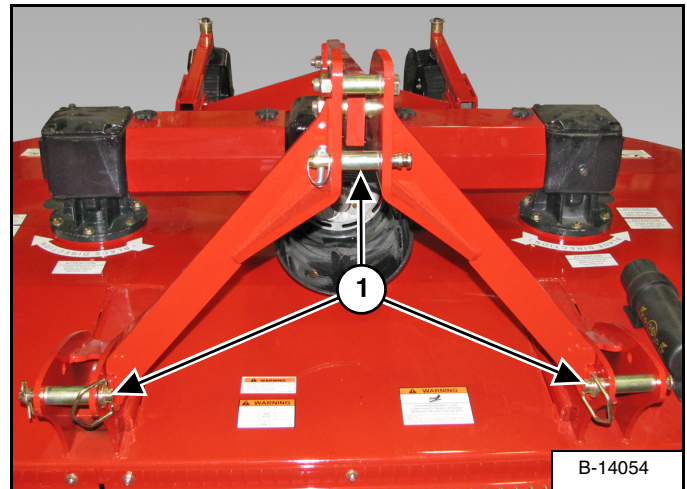

Install one 7/64" W x 1-1/8" x 2-7/8" pin sleeve, hitch pin and #9 hairpin clip (Item 1) [Figure 8] at the three implement mounting locations.

TRAILING MODEL

Assembly Instructions

Figure 9

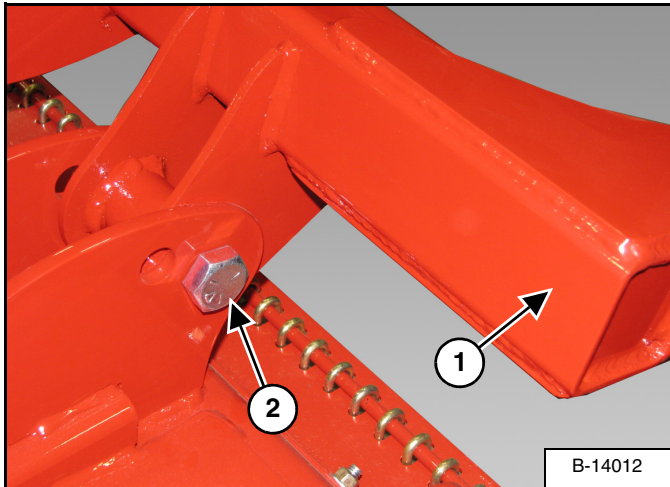

Locate the trailing arm weldment (Item 1) [Figure 9].

Place the trailing arm weldment inside the outer mounting brackets on the rear of the deck (both sides). Install one 7/64" W x 1-1/18" x 2-7/8" pin sleeve on a 7/8" x 5" bolt. Install the bolt assembly (Item 2) [Figure 9] through the mounting bracket and trailing arm weldment (both sides)

Figure 10

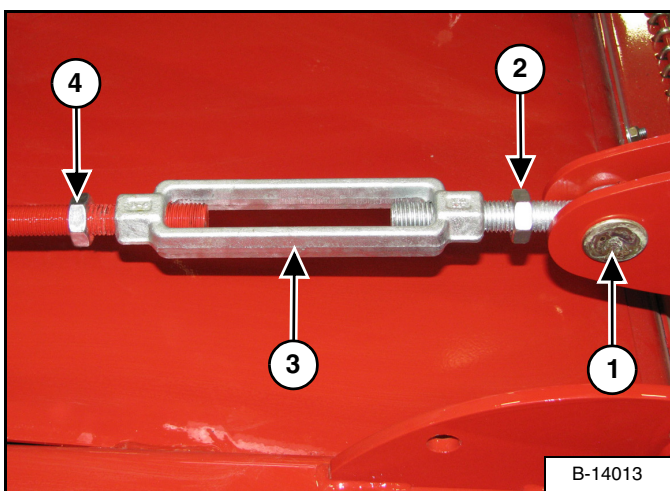

Align one 3/4" x 5" rod end with the inner mounting brackets on the rear of the deck. Install one control rod pin (Item 1) [Figure 10] through the mounting bracket and rod end and secure with one 3/16" x 1-1/2" cotter pin (both sides).

Thread one 3/4" (left hand thread) jam nut (Item 2) [Figure 10] onto the 3/4" x 5" rod end, approximately two inches (both sides).

Thread one 3/4" x 6" turnbuckle (Item 2) [Figure 10] onto the rod end until there is approximately one inch of exposed threads inside the turnbuckle (both sides).

Thread one 3/4" (left hand thread) jam nut (Item 4) [Figure 10] onto the level rod weldment, approximately two inches (both sides).

Thread the level rod weldment into the 3/4" x 6" turnbuckle (Item 3) [Figure 10] until there is approximately one inch of exposed threads inside the turnbuckle (both sides).

Figure 11

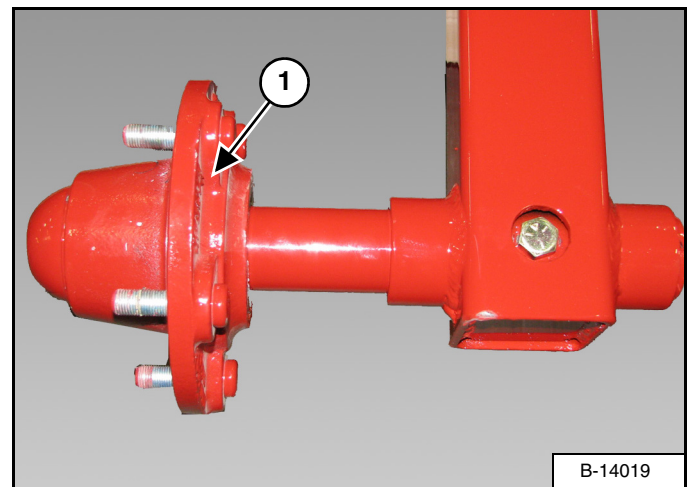

Install one hub assembly (Item 1) [Figure 11] into the trailing arm weldment (with hub to the outside).

Align mounting holes and install one 1/2" x 3" bolt down through the trailing arm weldment and shaft of the hub assembly. Install one 1/2" lock nut onto the bolt and tighten.

Repeat procedure for opposite side.

Figure 12

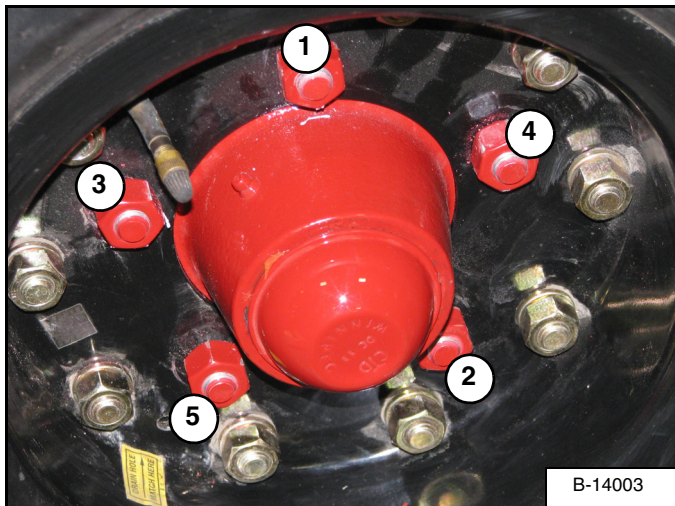

Install the tire assembly and five wheel nuts (Items 1 - 5) [Figure 12] (both sides).

Tighten wheel bolts in a criss-cross pattern [Figure 12]. Tighten wheel bolts to 93 ft. lb. (126 N•m) of torque (both sides).

Figure 13

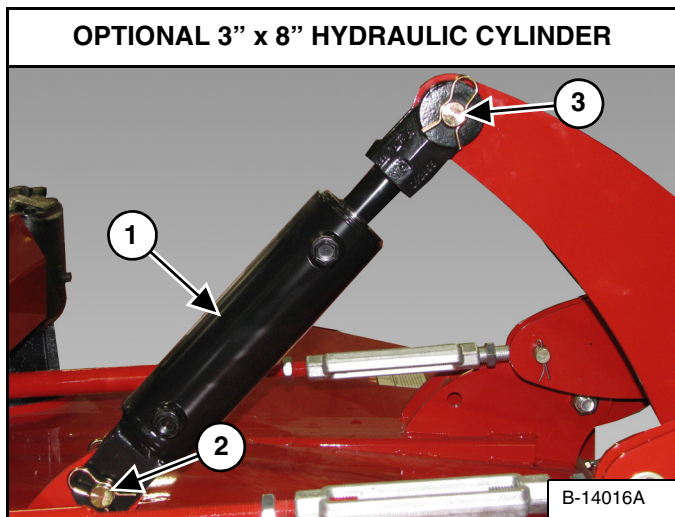

Place the hydraulic cylinder (Item 1) over the mounting plate on the rear of the deck (just behind splitter gearbox). Install one 1" x 4" clevis pin (Item 2) [Figure 13] through the base end of the cylinder and secure in place with two #9 hairpin clips.

Raise / rotate the trailing arm weldment up and align the rod end of the cylinder with the mounting bracket on the trailing arm weldment. Install one 1" x 4" clevis pin (Item 3) [Figure 13] through the rod end of the cylinder and secure in place with two #9 hairpin clips.

Figure 14

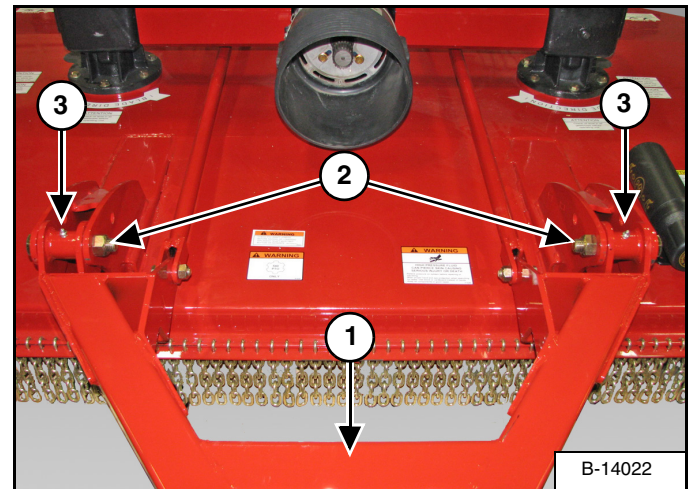

Locate the trailer hitch weldment (Item 1) [Figure 14]. Place the trailer hitch weldment inside the two mounting brackets on the front of the deck.

Install one 7/64" W x 1-1/8" x 2-7/8" pin sleeve onto a 7/8" x 5" bolt. Install the bolt assembly (Item 2) [Figure 14] through the mounting bracket and trailer hitch weldment (both sides). Install one 7/8" lock nut on the two bolts and tighten until the nut contacts the pin sleeve.

Install the two grease zerks (Item 3) [Figure 14].

Figure 15

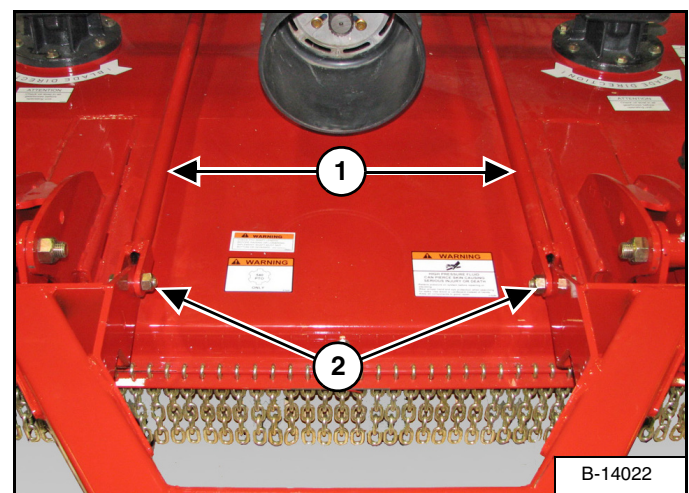

Align the two level rod weldments (Item 1) [Figure 15] with the mounting plates on the trailer hitch weldment.

Install one 5/8" x 2-1/4" Grade 8 bolt (Item 2) [Figure 15] through the level rod weldments and mounting plates on the trailer hitch weldment. Install one 5/8" lock nut on each bolt and tighten.

Figure 16

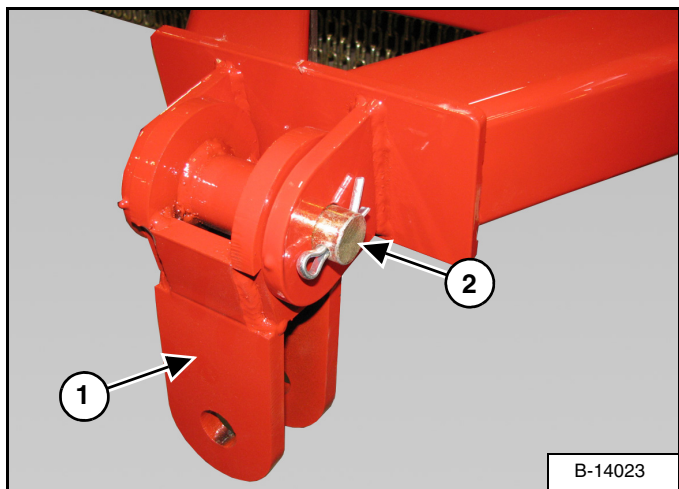

Install the swivel clevis weldment (Item 1) **[Figure 16]** into the mounting bracket on the front of the trailer hitch weldment.

Install one clevis pin (Item 2) **[Figure 16]** through the mounting bracket and swivel clevis weldment, the secure with 1/4" x 1-1/2" cotter pin.

Figure 17

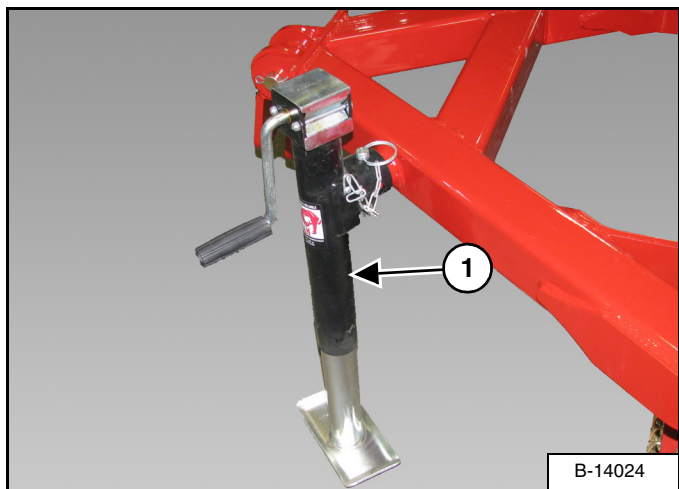

Install the side crank jack (Item 1) **[Figure 17]** onto the left side of the trailer hitch weldment.

Farm King



OPERATION

GENERAL INFORMATION37
 Pre - Operation Checklist37
 Break - In Checklist38
 Tractor Requirements38
 Entering And Leaving The Operator’s Position39
 Connecting The Rotary Cutter To The Tractor40
 Connecting The PTO Driveline41
 PTO Driveline42

PRE OPERATION45
 Recommended Deck Height45

OPERATING THE ROTARY CUTTER46
 Cutting Procedure46
 Cutting Recommendations49

TRANSPORTING50
 Requirements50
 Transporting Guidelines50
 Transporting Procedure51

Farm King



GENERAL INFORMATION

Pre - Operation Checklist

Before operating the Rotary Cutter for the first time and each time thereafter, check the following items:



AVOID INJURY OR DEATH

- Disengage the PTO, engage the machine’s parking brake, stop the engine and make sure all rotating components are completely stopped before connecting, disconnecting, adjusting or cleaning any PTO driven equipment.
- Always keep PTO shields and all guards in place when using PTO driven equipment.
- Disengage PTO for road travel.
- Keep hands, feet and clothing away.



AVOID INJURY OR DEATH

Wear safety glasses to prevent eye injury when any of the following conditions exist:

- When fluids are under pressure.
- Flying debris or loose material is present.
- Engine is running.
- Tools are being used.

1. Lubricate the equipment per the schedule outline in the Maintenance Section. (See “SERVICE SCHEDULE” on page 57.)
2. Check the rotary cutter hitch for damaged, loose or missing parts. Repair as needed before operation.
3. Check that tire pressure (air craft tires only) is 40 psi (276 kpa).

4. Check that wheel bolt torque is 93 ft. lb. (126 N•m).
5. Fully clean the equipment. (See “CLEANING THE ROTARY CUTTER” on page 66.)
6. Inspect all safety reflective decals, slow moving vehicle decals and lights where applicable.

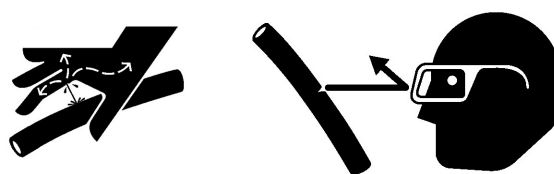

Leaking fluids under pressure can enter the skin and cause serious injury or death. Immediate medical attention is required. Wear goggles. Use cardboard to check for leaks.

7. Check condition of all hydraulic components for leaks. Repair as required.

NOTE: Do not operate with hydraulic leaks.

Break - In Checklist

Check the following mechanical items after 1 hour of operation and again after 10 hours of operation:

1. Check condition of all hydraulic components for leaks. Tighten fittings to correct leaks or replace components. Do not operate with hydraulic leaks.

Figure 18

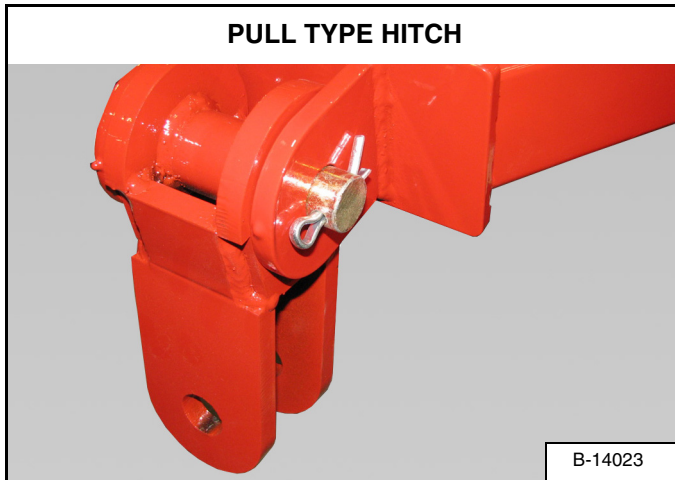
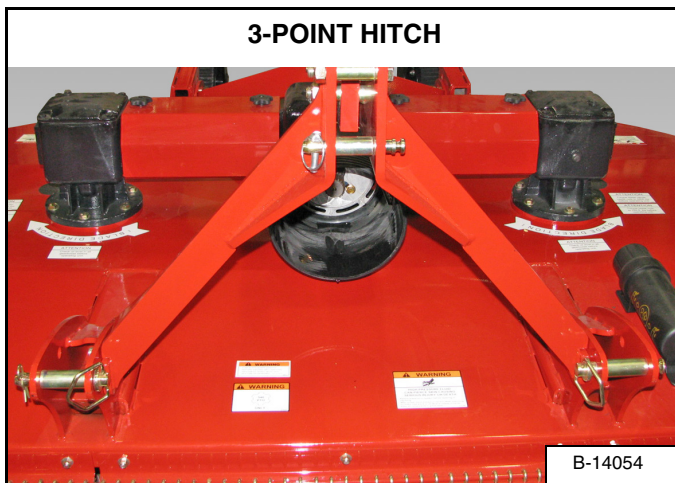

Figure 19



2. Check the rotary cutter hitch for damaged, loose or missing parts [Figure 18] or [Figure 19]. Repair as needed before operation.
3. Check for loose fasteners and hardware. Tighten as required.
4. Check that tire pressure (air craft tires only) is 40 psi (276 kpa).
5. Check that wheel bolt torque is 93 ft. lb. (126 Nm).

Tractor Requirements



AVOID SERIOUS INJURY OR DEATH

The tractor must be equipped with an approved Roll Over Protection Structure (ROPS) and safety belts to help prevent personal injury or death caused by tractor roll over.



- Do NOT exceed 540 RPM PTO (if equipped).
- Keep PTO shields and all guards in place.
- Keep away from moving parts.
- Keep bystanders away.

The rotary cutter will require a tractor with minimum 40 hp (48 kw) and three pair remote hydraulic outlets.



Towing Vehicle / Tractor must have adequate braking capacity to safely control trailing load. Do not exceed 20 mph (32 km/h).

Drawbar Adjustment

Figure 20

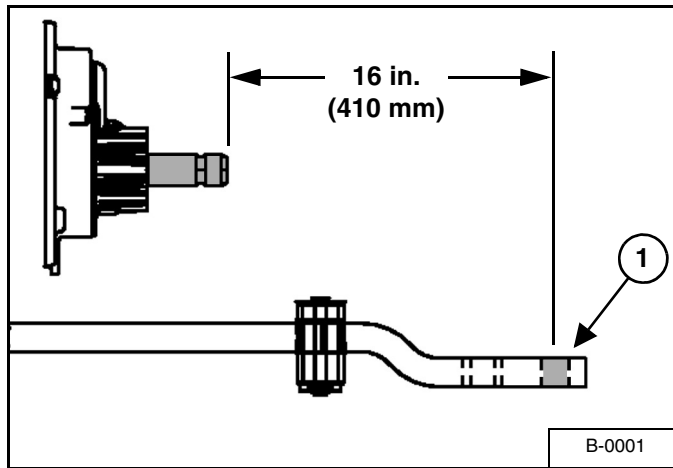

Adjust the tractor's drawbar in / out, until the center of the hitch pin hole (Item 1) [Figure 20] is 16 inches (410 mm) from the end of the tractor's PTO shaft. See your tractor's owner's manual for correct adjustment procedures.

Entering And Leaving The Operator's Position

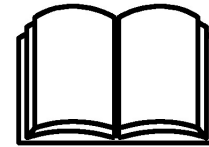

Follow the instructions in your tractor's operation manual for the correct procedure.

Entering The Operator's Position

Move to the operator's position, start the engine and release the parking brake.

Leaving The Operator's Position



AVOID INJURY OR DEATH

Before you leave the operator's position:

- **Always park on a flat level surface.**
- **Place all controls in NEUTRAL.**
- **Engage the park brake.**
- **Stop the engine and remove the key.**
- **Wait for all moving parts to stop.**

Park the tractor / equipment on a flat level surface.

Place all controls in neutral, engage the park brake, stop the engine and wait for all moving parts to stop. Leave the operator's position.

Connecting The Rotary Cutter To The Tractor

Figure 21

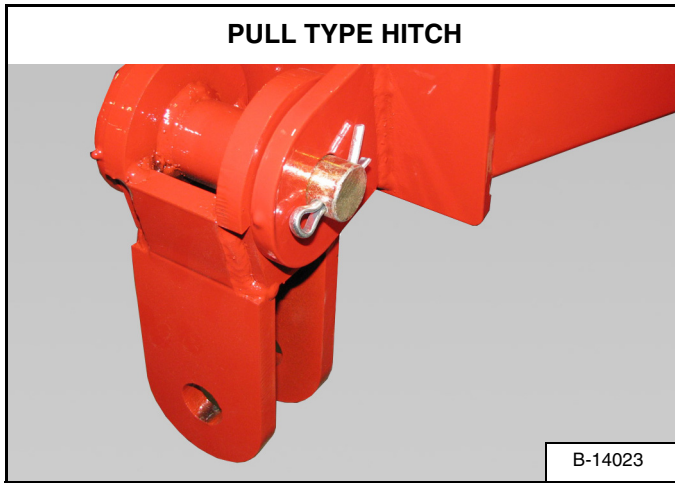
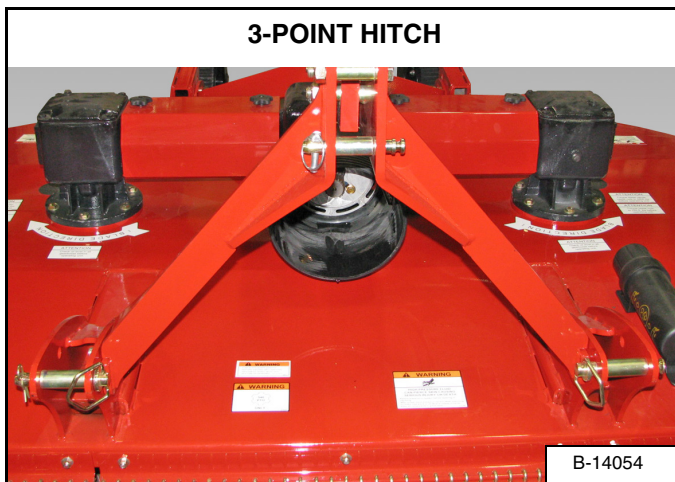

Figure 22



Always inspect the tractor’s drawbar and Rotary Cutter hitch [Figure 21] or [Figure 22] before connecting. See the tractor’s owner’s manual.

Verify that the tractor’s drawbar is adjusted correctly for use with the Rotary Cutter. (See “Drawbar Adjustment” on page 39.)

Enter the operator’s position. (See “Entering The Operator’s Position” on page 39.)

Move the tractor into position in front of the Rotary Cutter.

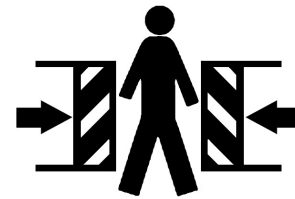

AVOID INJURY OR DEATH

Before moving the tractor, look in all directions and make sure no bystanders, especially small children are in the work area. Do not allow anyone between the tractor and the equipment when backing up to the equipment for connecting.

Move the tractor backwards, aligning the drawbar with the Rotary Cutter hitch.

NOTE: The jack may need to be lowered or raised for proper alignment of the drawbar and hitch.

If the Rotary Cutter hitch needs to be adjusted, stop the tractor when drawbar is just in front of the Rotary Cutter hitch.

Leave the operator’s position. (See “Leaving The Operator’s Position” on page 39.)

Connecting The PTO Driveline



AVOID INJURY OR DEATH

Warnings on the machine and in the manuals are for your safety. Failure to obey warnings can cause serious injury or death.

NOTE: Clean and grease tractor’s PTO shaft and PTO driveline coupling each time driveline is connected.

Stop the engine and leave the operator’s position. (See “Leaving The Operator’s Position” on page 39.)



Improper hitch installation can cause PTO driveline damage.

- Do not modify the hitch or use an unapproved hitch.
- Make sure the PTO driveline is of adequate length and that u-joints are in the correct phase.

Remove the PTO driveline from the storage position (if applicable).

Figure 23

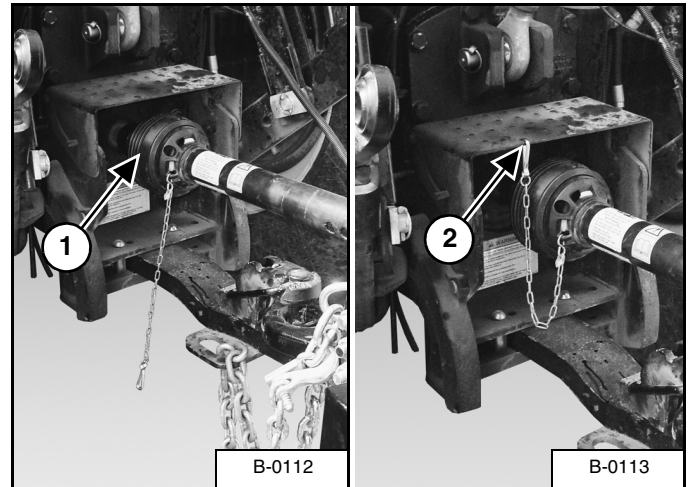

Retract the collar and slide the PTO driveline (Item 1) [Figure 23] onto the tractor PTO shaft until it locks onto the shaft. Push and pull on the PTO driveline to verify it is securely attached to the PTO shaft. Install PTO driveline safety chain (Item 2) [Figure 23].

NOTE: The PTO driveline must have a means to retain it to the PTO shaft on the tractor.



- Do NOT exceed 540 RPM PTO (if equipped).
- Keep PTO shields and all guards in place.
- Keep away from moving parts.
- Keep bystanders away.

PTO Driveline

PTO Driveline Length Check

NOTE: Due to variations in distances between tractor PTO shafts and implement input shafts, drivelines may need to be shortened or a longer shaft may be required. When fitting the implement to the tractor, the PTO driveline, with telescoping sections, must be inspected. When the sections are at the most compressed operating position, the sections must not “bottom out”. At its shortest length, there must be at least 2 in. (50.8 mm) of clearance between each section end and opposite section end at the most compressed operating position. When the sections are at the most extended position, there must be sufficient engagement between the sections. At its farthest operating extension, a minimum section engagement of 33% of shaft length must be maintained.



AVOID INJURY OR DEATH

- Do NOT exceed the rated implement PTO speed.
- Stay clear of rotating driveline.
- Keep bystanders away.
- Keep hands, feet, clothing and long hair away.
- Keep PTO shields and all guards in place.
- Disengage PTO, move the tractor controls to the Neutral position, stop the engine and make sure all rotating components are stopped before leaving the operator’s position.
- Do NOT service the tractor or implement with the PTO engaged.
- Do NOT service the implement in a raised position unless properly blocked and with all rotating components stopped.
- Disengage PTO for road travel.

PTO Driveline Bottoming Out Check

Stop the engine and leave the operator’s position. (See “Leaving The Operator’s Position” on page 39.)

Make sure the PTO driveline and all rotating components have come to a complete stop before leaving the operator’s position (if applicable).

Figure 24

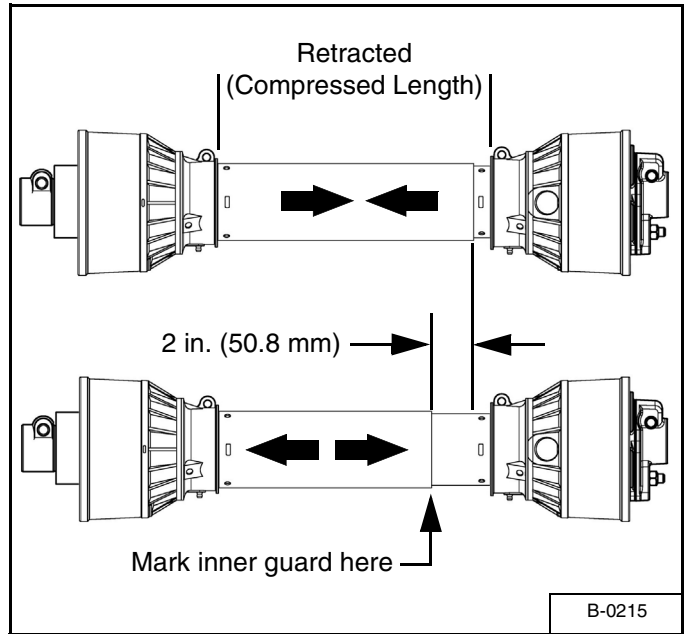

1. Disconnect the PTO driveline from the tractor and slide the PTO driveline together until fully retracted (compressed).
2. Measure the retracted (compressed) length of PTO driveline [Figure 24].
3. Extend the PTO driveline 2 in. (50.8 mm) from the retracted length and place a mark on the inner guard at the end of the outer guard [Figure 24].
4. Reattach the PTO driveline to the tractor PTO shaft.
5. Enter the operator’s position. (See “Entering The Operator’s Position” on page 39.) Start the engine.
6. With the rear PTO DISENGAGED, raise and lower the implement and watch the PTO driveline extend and retract.
7. If the outer PTO driveline guard slides in (retracts) over the mark at any point of travel, the PTO driveline needs to be shortened.

Reducing The PTO Driveline Length

Stop the engine and leave the operator's position. (See "Leaving The Operator's Position" on page 39.)

Make sure the PTO driveline and all rotating components have come to a complete stop before leaving the operator's position.



AVOID INJURY OR DEATH

- Do NOT exceed the rated implement PTO speed.
- Stay clear of rotating driveline.
- Keep bystanders away.
- Keep hands, feet, clothing and long hair away.
- Keep PTO shields and all guards in place.
- Disengage PTO, move the tractor controls to the Neutral position, stop the engine and make sure all rotating components are stopped before leaving the operator's position.
- Do NOT service the tractor or implement with the PTO engaged.
- Do NOT service the implement in a raised position unless properly blocked and with all rotating components stopped.
- Disengage PTO for road travel.

Remove the PTO driveline from the tractor and place in storage position (if equipped).

Enter the operator's position. (See "Entering The Operator's Position" on page 39.) Start the engine.

Raise or lower the Rotary Cutter to get the shortest distance between the tractor PTO shaft and Rotary Cutter gearbox PTO shaft.

Stop the engine and leave the operator's position. (See "Leaving The Operator's Position" on page 39.)

Pull the PTO driveline apart and reinstall each individual section; one half to the tractor PTO shaft and one half to the implement gearbox PTO shaft.

Figure 25

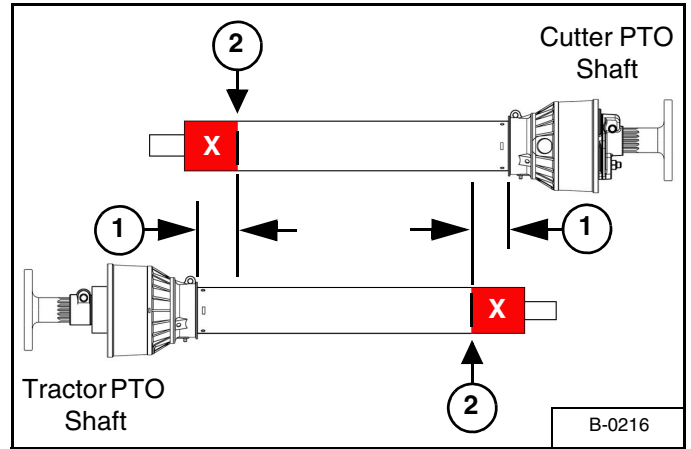

1. Hold PTO driveline sections parallel to one another and measure back 2 in. (50.8 mm) (Item 1) from the yoke of each section and place mark on opposite section. Cut the plastic shield at this length (Item 2) [Figure 25].

Figure 26

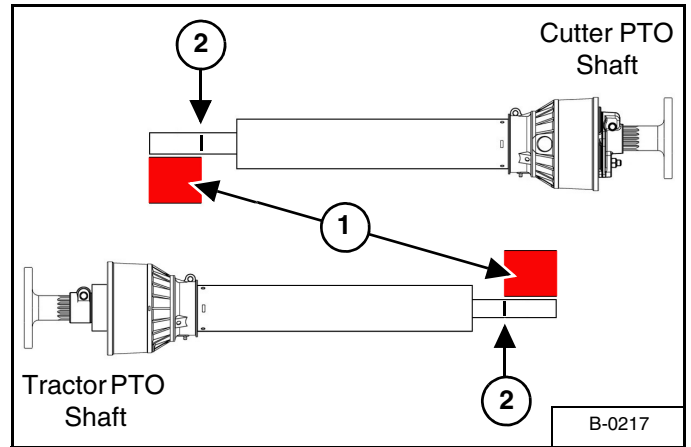

2. Using the plastic guard lengths that were cut off in [Figure 25], align the cut off lengths (Item 1) with the end of the inner & outer shafts. Place a mark (Item 2) [Figure 26] on the inner & outer shafts and cut the inner & outer shafts off at this length.
3. Round off all sharp edges and debur.
4. Thoroughly grease and install the PTO driveline halves together.
5. Recheck for proper operation.

PTO Driveline Engagement Check

Stop the engine and leave the operator’s position. (See “Leaving The Operator’s Position” on page 39.)

Make sure the PTO driveline and all rotating components have come to a complete stop before exiting the compact tractor.



AVOID INJURY OR DEATH

- **Do NOT exceed the rated implement PTO speed.**
- **Stay clear of rotating driveline.**
- **Keep bystanders away.**
- **Keep hands, feet, clothing and long hair away.**
- **Keep PTO shields and all guards in place.**
- **Disengage PTO, move the tractor controls to the Neutral position, stop the engine and make sure all rotating components are stopped before leaving the operator’s position.**
- **Do NOT service the tractor or implement with the PTO engaged.**
- **Do NOT service the implement in a raised position unless properly blocked and with all rotating components stopped.**
- **Disengage PTO for road travel.**

1. Disconnect the PTO driveline from the tractor and fully slide the driveline sections together (retracted).

Figure 27

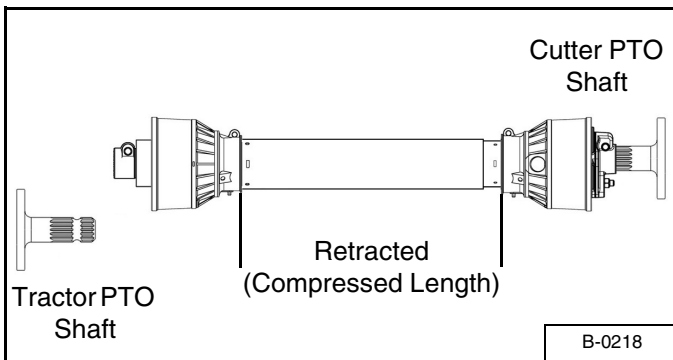

2. Measure the retracted (compressed) length of the PTO driveline between the bases of the plastic guards [Figure 27].

3. Multiply the retracted driveline length by 1.667 to determine the PTO driveline Maximum Operating Length. (i.e.: 25.5 in. (647,7 mm) x 1.667= 42.5 in. (1079,7 mm) Maximum Operating Length).
4. Attach the PTO driveline to the tractor PTO output shaft.
5. Enter the operator’s position. (See “Entering The Operator’s Position” on page 39.)
6. With the PTO driveline attached, position the Rotary Cutter to where the telescoping PTO driveline is at its maximum operating extension.
7. Stop the engine and leave the operator’s position. (See “Leaving The Operator’s Position” on page 39.) Make sure the PTO driveline and all rotating components have come to a complete stop before leaving the operator’s position.

Figure 28

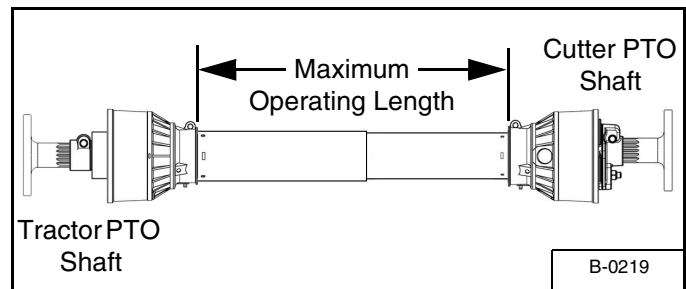

8. Measure the length of the PTO driveline between the bases of the plastic shields [Figure 28] to determine the maximum operating length.

A. If the measured maximum operating length is less than the Maximum Operating Length calculation (from Step 3), the PTO driveline has adequate engagement

B. If the measured maximum operating length is equal to or more than the Maximum Operating Length calculation (from Step 3), the PTO driveline does not have adequate engagement and should be replaced with a longer driveline. See your Farm King dealer for available PTO drivelines.

PRE OPERATION

Recommended Deck Height

! IMPORTANT

- **Adjust the deck height to the tractor's drawbar. Drawbar heights vary depending on the tractor being used.**
 - **The Rotary Cutter usually performs best with the front raised higher than the rear.**
-

Cutting Conditions

Light Material / Normal Cutting - Set front of deck level to one inch (25.4 mm) higher than the rear.

Brush Or Dense Tall Weeds - Set front of deck two - three inches (51 - 76 mm) higher than the rear.

Rough Ground Cutting - Adjust the front of the cutter two - three inches (51 - 76 mm) higher than the rear to hold the front blade up, keeping the front blade from contacting the rough ground.

NOTE: Operator can adjust deck to a height to best obtain the finished cutting desired.

OPERATING THE ROTARY CUTTER

Cutting Procedure

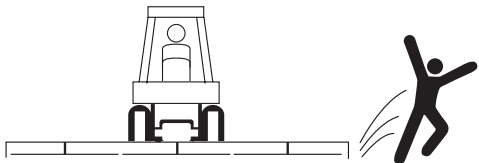

THROWN OBJECT HAZARD

To prevent serious injury or death from thrown objects:

- Stay clear and watch out for bystanders. Stop if bystanders come close to work area. Keep all shields in place. Use protective shields on all discharge openings at front and rear of deck whenever possible.
- Before working on mower: Disengage power, shut off engine, remove key and make sure all blades have stopped turning.



ROTATING BLADES CAN CAUSE SERIOUS INJURY OR DEATH

- Stay clear of rotating parts.
- Blades may rotate for several minutes after power shut off.
- Do not place hands or feet under or into cutter.
- Disengage power, stop engine, set park brake, remove ignition key and make sure blades have stopped turning before leaving cab.

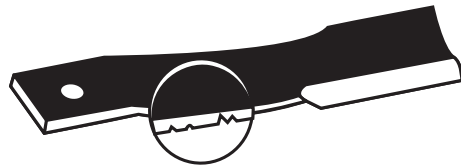

DAMAGED BLADES CAN CAUSE SERIOUS INJURY OR DEATH

- Inspect blades daily for chips, cracks, wear and abnormal bends.
- Replace blades with genuine Farm King blades only.
- Unbalanced blades are dangerous.
- Replace blades in pairs.



AVOID SERIOUS INJURY OR DEATH

Do not operate Rotary Cutter when deck or wings are raised. Exposed rotating blades create a potential hazard of thrown objects which may lead to serious injury or death.

⚠ WARNING

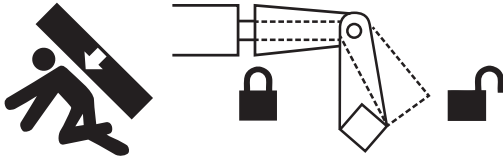

- Purge air from hydraulic system before attempting to raise or lower implement.

⚠ WARNING



- Do NOT exceed 540 RPM PTO speed.
- Keep PTO shields and all guards in place.
- Keep away from moving parts.
- Keep bystanders away.
- Verify that the PTO driveline does not contact the cutter when raising and lowering or when cornering.

⚠ IMPORTANT

Do not allow hydraulic hoses to contact brush, branches, and other objects that could cause damage to the hydraulic hoses.

⚠ IMPORTANT

Do not exceed the rated PTO speed. Excessive speed will cause damage to the drive components.

⚠ IMPORTANT

Avoid making tight turns where the rear tractor tires and three-point arms may contact the rotary cutter hitch, PTO drivelines or wing decks. Fully raise the three-point arms when operating / transporting the rotary cutter.

Connect the rotary cutter to the tractor. (See “Connecting The Rotary Cutter To The Tractor” on page 40.)

Enter the tractor, start the engine and release the parking brake.

Raise the rotary cutter to the travel position.

Move the tractor and rotary cutter to the work area.

Position the tractor and rotary cutter at the starting point of cutting area.

Stop the tractor, engage the parking brake and turn the engine off.

Leave the operator’s position. (See “Entering And Leaving The Operator’s Position” on page 39.)

Adjust the rotary cutter to the desired cutting height. (See “Recommended Deck Height” on page 45.)

Enter the tractor, start the engine and release the parking brake.



WARNING



- **Do NOT exceed 540 RPM PTO (if equipped).**
- **Keep PTO shields and all guards in place.**
- **Keep away from moving parts.**
- **Keep bystanders away.**

540 RPM Operating PTO Speed

Engage the tractor’s PTO, increase tractor PTO speed to 540 rpm when doing normal cutting.

NOTE: If the forward speed is too high, a lower gear can be used.



IMPORTANT

Recommended operating ground speed is 0 - 5 mph (0 - 8 km/h). Use slower speeds when operating on or near steep slopes, ditches, drop-offs, rough terrain, overhead obstructions, power lines, or when avoiding obstacles and other foreign debris.

Cutting Recommendations

NOTE: Loss of power / PTO speed will result in uneven cutting. Adjust travel speed as required for material being cut, while maintaining the rated operating PTO speed (540 rpm / 1000 rpm PTO speed).

Light Material / Normal Cutting

Adjust the front of the cutter one inch (25.4 mm) higher than the rear or level for light / normal cutting.

Brush Or Dense Tall Weeds

Adjust the front of the cutter two - three inches (51 - 76 mm) higher than the rear to better shred brush or dense tall weeds.

Rough Ground Cutting

Adjust the front of the cutter two - three inches (51 - 76 mm) higher than the rear to hold the front blade up, keeping the front blade from contacting the rough ground.

Figure 29

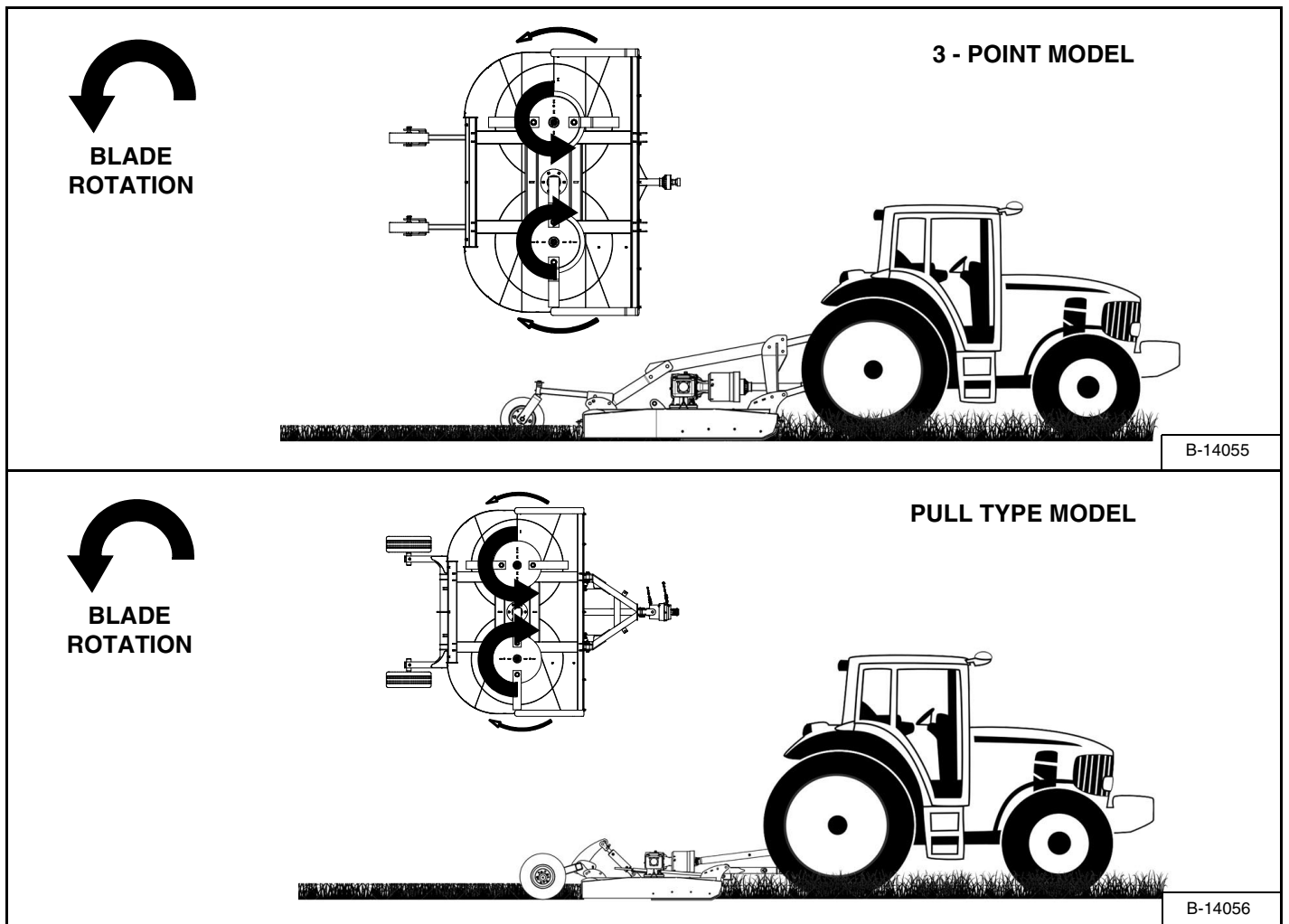

Adjust Rotary Cutter to the desired height, engage the tractor PTO, lower the Rotary Cutter and begin cutting [Figure 29].

**TRANSPORTING
Requirements**



ELECTROCUTION HAZARD

To prevent serious injury or death from electrocution:

- Be aware of overhead power lines.
- Electrocution can occur without direct contact.



Use of an unapproved hitch or tractor / tow vehicle can result in loss of control, leading to serious injury or death.

Tractor / tow vehicle and hitch must have the rated capacity to tow equipment.



- Do not operate the unit before reading and understanding the Operator Manual.
- Make certain everyone is clear of the equipment before applying power or moving the machine.
- Raise unit to the recommended transport position before transporting.
- Disconnect PTO driveline from the tractor before moving or transporting.



Never exceed 20 mph (32 kph).

Comply with federal, state, local and provincial laws regarding the transport of farm equipment on public roadways.

Verify that the tractor / tow vehicle is approved for transporting the equipment and that the equipment is securely attached to the tractor / tow vehicle.

Verify safety chain is installed and properly connected before transporting equipment.

Verify that the SMV (Slow Moving Vehicle) emblem, all lights and reflectors are clean and visible.

Disconnect the PTO driveline from the tractor before transporting.

Transporting Guidelines

The ratio of the tractor / tow vehicle weight to the loaded equipment weight plays an important role in defining acceptable travel speed.

TRAVEL SPEED - Acceptable travel speed.

WEIGHT RATIO - Weight of fully equipped or loaded implement(s) relative to weight of tractor / tow vehicle.

TRAVEL SPEED	WEIGHT RATIO
Up to 20 mph (32 kph)	1 to 1 (or less)
Up to 10 mph (16 kph)	2 to 1 (or less)
DO NOT TOW	More than 2 to 1

Transporting Procedure

Enter the tractor, start the engine and engage the tractor's hydraulics.

Using the tractor's hydraulic controls, fully raise the deck. Run the tractor engine at low idle.

Stop the tractor, engage the parking brake and turn the engine off.

Leave the operator's position. (See "Entering And Leaving The Operator's Position" on page 39.)

Figure 30

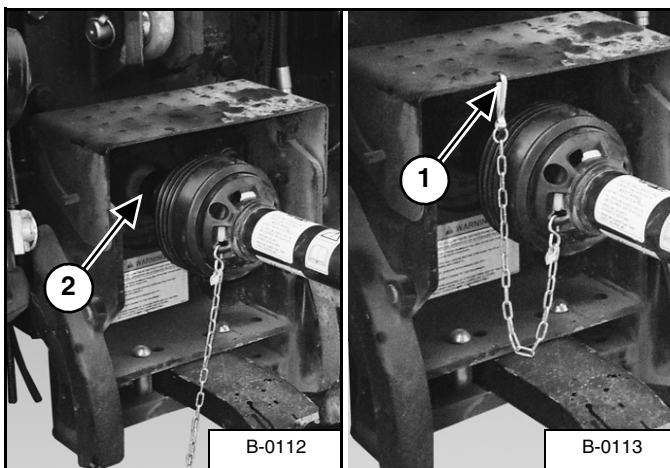

Remove the PTO driveline safety chain (Item 1). Retract the collar (Item 2) [Figure 30] and slide the PTO driveline off the tractor PTO shaft.

Remove the PTO driveline from the gearbox.

Fully raise the jack and rotate into the transport position (horizontal).

Verify that the Rotary Cutter is securely fastened to the tractor / tow vehicle and that the hitch safety chain is properly attached to the Rotary Cutter and tractor / tow vehicle.

Verify that the SMV (Slow Moving Vehicle) sign is attached and visible.

Verify that the amber lights are clean and operating correctly.

Farm King



MAINTENANCE

TRUBLESHOOTING55
 General Chart55
 Blades56

SERVICE SCHEDULE57
 Maintenance Intervals57

LUBRICATION58
 Recommendations58
 Locations58

SPLITTER GEARBOX61
 Checking Gear Oil Level61
 Changing Gear Oil61

BLADES62
 Removal And Installation62

BLADE PAN63
 Removal And Installation63

AXLE65
 Wheel Bolts Torque65
 Tire / Wheel Replacement65
 Wheel Bearings65
 Tire Pressure (Aircraft Type)65

CLEANING THE ROTARY CUTTER66

SAFETY SIGN (DECAL) INSTALLATION66
 Procedure66

STORAGE AND RETURN TO SERVICE67
 Storage67
 Return To Service67

Farm King



TROUBLESHOOTING

General Chart



Instructions are necessary before operating or servicing equipment. Read and understand the Operator And Parts Manual and safety signs (decals) on equipment. Follow warnings and instructions in the manuals when making repairs, adjustments or servicing. Check for correct function after adjustments, repairs or service. Untrained operators and failure to follow instructions can cause injury or death.

NOTE: If a problem is encountered that is difficult to solve, even after having read through this troubleshooting section, please call your local distributor or dealer. Before you call, please have this Operator And Parts Manual and the serial number of your machine at hand.

PROBLEM	CAUSE	CORRECTION
Slip clutches slipping under light load.	Scalping the ground.	Raise cutting height.
	Clutch out of adjustment.	Adjust clutch.
	Worn clutch plates	Replace clutch plates.
	Debris or foreign object caught between clutch plate.	Remove foreign object.
PTO driveline failure.	Slip clutch seized.	Adjust or replace slip clutch.
	Shock load.	Avoid blades from contacting solid objects.
	PTO driveline dry.	Lubricate PTO driveline.
Bent PTO driveline shaft.	PTO driveline contacting cutter frame.	Reduce lift height in transport position.
	PTO driveline tractor draw bar.	Re-position draw bar.
	PTO driveline bottoming out.	Shorten driveline.
	PTO driveline binding.	Lubricate PTO driveline.
PTO driveline telescoping tube failure.	Shock load.	Keep blades from contacting solid objects.
PTO driveline telescoping tube wearing.	PTO driveline dry.	Lubricate PTO driveline.
Gearbox seal leaking.	Gearbox over-filled.	Drain excess gear oil from gearbox.
	Damaged or worn seals.	Replace seals.
	Debris wrapped around shaft.	Remove debris and inspect seals. Replace as needed.
Blade carrier damaged.	Shock load.	Keep blades from contacting solid objects.
Excessive skid wear.	Ground contact.	Adjust cutter height.
	Rotary cutter set too low.	Adjust cutter height.

PROBLEM	CAUSE	CORRECTION
Blades do not rotate.	Blades overlapped when wings raised to transport position.	Separate cutting blades before lowering wings.
	Tractor equipped with instant on PTO.	Engage PTO at low RPMs, then slowly increase engine RPMs to full PTO speed.
	Tractor equipped with instant off PTO.	Decrease engine RPMs slowly to an idle before disengaging PTO.
Excessive blade wear.	Operating on sandy ground.	Adjust cutter height.
	Blades contacting the ground.	Adjust cutter height.
Blades loosen during operation.	Blades not tightened correctly.	Tighten blades.
	PTO operating RPMs too high.	Lower RPMs to correct operating speed.
Damaged or breaking blades.	Contacting solid objects.	Keep blades from contacting solid objects.
Blade carrier loose.	Shaft nut loose.	Tighten shaft nut to correct torque.
	Gearbox bearings or shaft damaged.	Replace bearings, shaft or gearbox as needed.
Damaged blade carrier.	Contacting solid objects.	Avoid blades from contacting solid objects.

Blades

PROBLEM	CAUSE	CORRECTION
Excessive blade wear.	Scalping the ground / contacting solid objects.	Raise cutting height.
Blade bolts loosening.	Blade bolts not torqued properly.	Tighten blade bolts to proper torque.
	Lock nut worn out.	Replace lock nut.
	Cutting in very wet conditions.	Allow work area to dry.
	Cutting too low, scalping ground.	Raise cutting height.
	Cutting too low in rocky conditions.	Raise cutting height.
Blades breaking.	Cutting too low in rocky conditions.	Raise cutting height.
	Damaged or extremely worn blades.	Replace blades.

SERVICE SCHEDULE

Maintenance Intervals

Maintenance work must be done at regular intervals. Failure to do so will result in excessive wear and early failures. The service schedule is a guide for correct maintenance of the 820 Rotary Cutter.



WARNING

Instructions are necessary before operating or servicing equipment. Read and understand the Operator and Parts Manual and safety signs (decals) on equipment. Follow warnings and instructions in the manuals when making repairs, adjustments or servicing. Check for correct function after adjustments, repairs or service. Untrained operators and failure to follow instructions can cause injury or death.

#	DESCRIPTION	SERVICE PROCEDURES					
		Check	Clean	Lube	Change	Adjust	Drain
Daily Maintenance (or every 8 hours)							
1	Tire Pressure	•					
2	Wheel Bolts	•					
3	Gearbox			•			
4	Splitter			•			
5	PTO Drivelines			•			
6	Blades	•					
7	Blade Pan	•					
8	Rubber Springs	•					
9	All Hardware	•					
10	Guards	•					
Weekly (or every 50 hours)							
11	Axle Bearing	•		•			
12	Adjustable Turnbuckle	•		•			
13	Hitch Frame	•		•			
14	Center Axle	•		•			
Annually (or every 500 hours)							
15	Axle Bearings	•		•			

LUBRICATION

Recommendations

Always use a good quality multi-purpose / lithium base grease when lubricating the equipment.



Do not over-grease bearings. Greasing too often can damage seals and lead to premature bearing failure.

- Always use a hand-held grease gun.
- Clean fitting before greasing, to avoid injecting dirt and grit.
- Replace and repair broken fittings immediately.
- If fittings will not take grease, remove and clean thoroughly. Replace fitting if necessary.

Locations



Fluid such as engine oil, hydraulic fluid, coolants, grease, etc. must be disposed of in an environmentally safe manner. Some regulations require that certain spills and leaks on the ground must be cleaned in a specific manner. See local, state and federal regulations for the correct disposal.

Lubricate the following grease locations EVERY 4 HOURS:

Figure 31

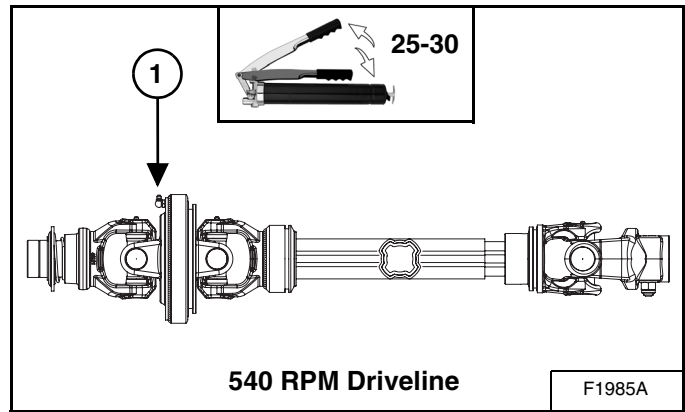

Apply 25-30 pumps of grease to CV (Constant Velocity) body (Item 1) [Figure 31].

Lubricate the following grease locations EVERY 8 HOURS:

Figure 32

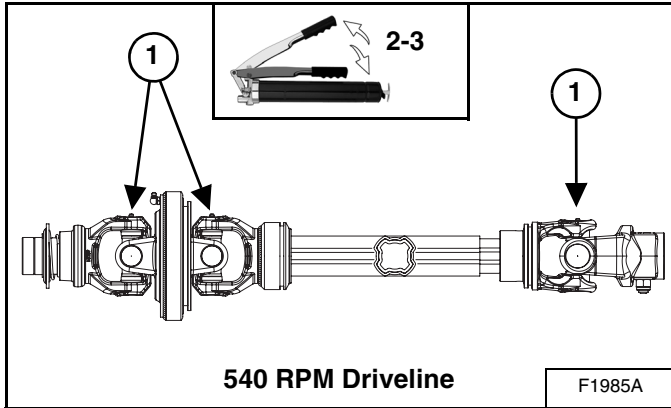

Apply two - three pumps of grease to the u-joints (Item 1) [Figure 32].

Figure 33

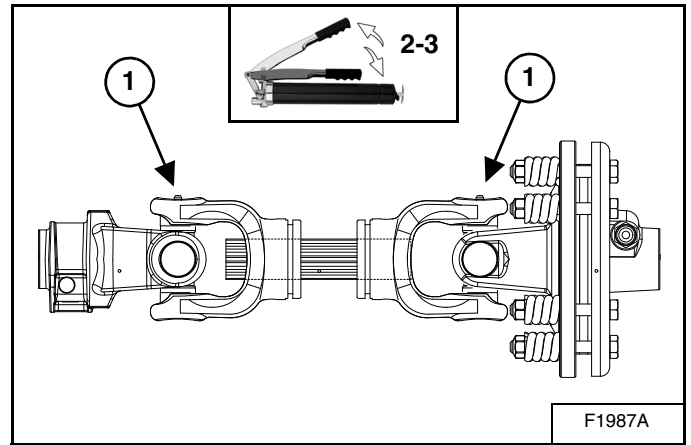

Apply two - three pumps of grease to the u-joints (Item 1) [Figure 33] of the slip clutch driveline.

Figure 34

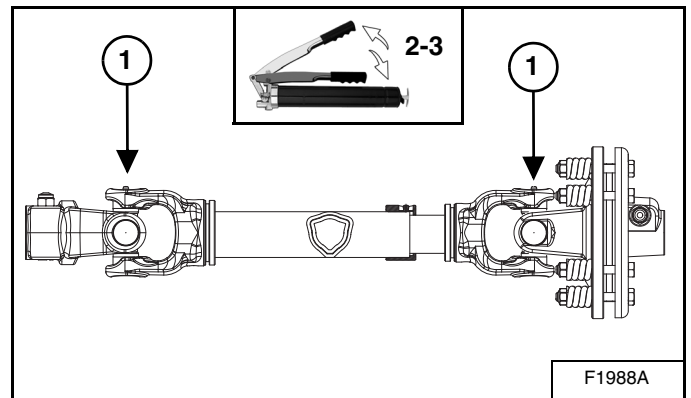

Apply two - three pumps of grease to u-joints (Item 1) [Figure 34] of the splitter driveline.

Figure 35

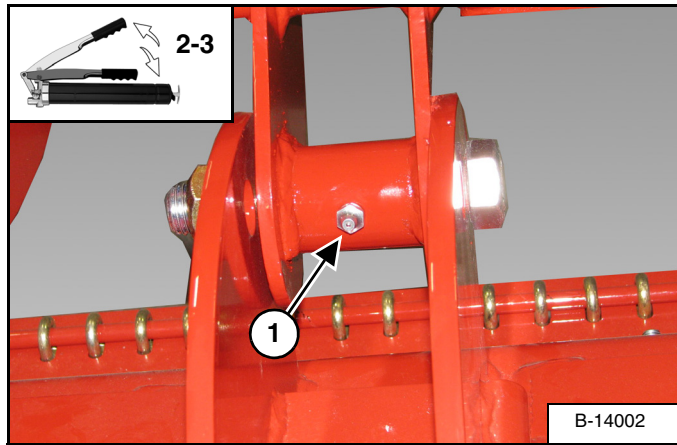

Apply two - three pumps of grease to the axle pivots (Item 1) [Figure 35] (LH & RH locations).

Figure 36

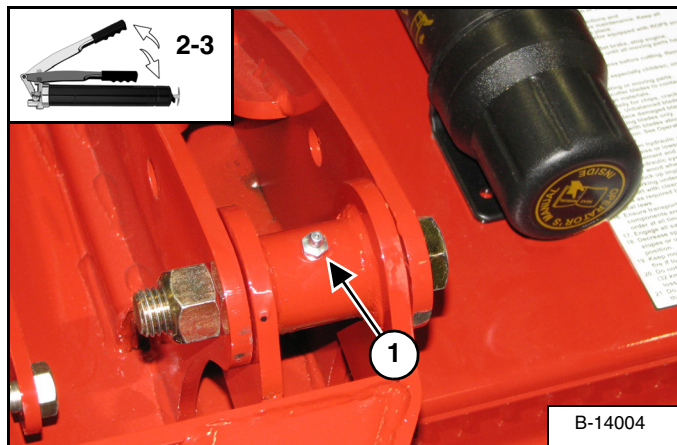

Apply two - three pumps of grease to the hitch pivot pin (Item 1) [Figure 36] (both sides).

Figure 37

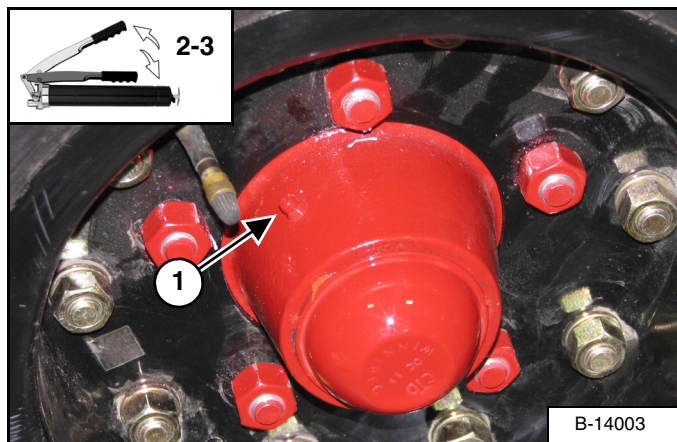

Apply two - three pumps of grease to the wheel bearing (Item 1) [Figure 37].

SPLITTER GEARBOX

Checking Gear Oil Level

Park the tractor and Rotary Cutter on a flat level surface.

! IMPORTANT

Allow gear oil to settle into the bottom cavity of the gearbox for approximately 15-20 min. before checking level on dipstick.

Figure 38

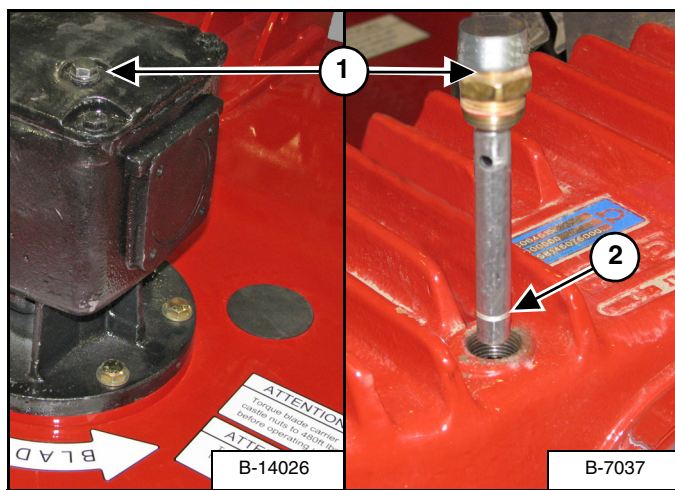

NOTE: To get an accurate reading of oil level, do not screw in the dipstick.

Remove dipstick / vent plug (Item 1) [Figure 38].

Wipe the dipstick clean. Place the dipstick back into the splitter gearbox until the dipstick makes contact with the splitter gearbox. Pull dipstick out and check gear oil level.

The gear oil level should be at the fill line (Item 2) [Figure 38].

Add SAE 80W-90 gear oil until oil reaches the dipstick fill line (Item 2). Install and tighten dipstick / vent plug (Item 1) [Figure 38].

! IMPORTANT

Wait approximately 15-20 min. after filling the splitter gearbox to allow gear oil to settle into the bottom cavity before checking level on dipstick.

Changing Gear Oil

! IMPORTANT

Replace the gear oil in new gearboxes after first 50 hours of operation. Then replace the gear oil annually.

Park the tractor and Rotary Cutter on a flat level surface.

Leave the operator's position. (See "Leaving The Operator's Position" on page 39.)

! WARNING

Always wear proper hand and eye protection when servicing the implement.

! IMPORTANT

Fluid such as engine oil, hydraulic fluid, coolants, grease, etc. must be disposed of in an environmentally safe manner. Some regulations require that certain spills and leaks on the ground must be cleaned in a specific manner. See local, state and federal regulations for the correct disposal.

Figure 39

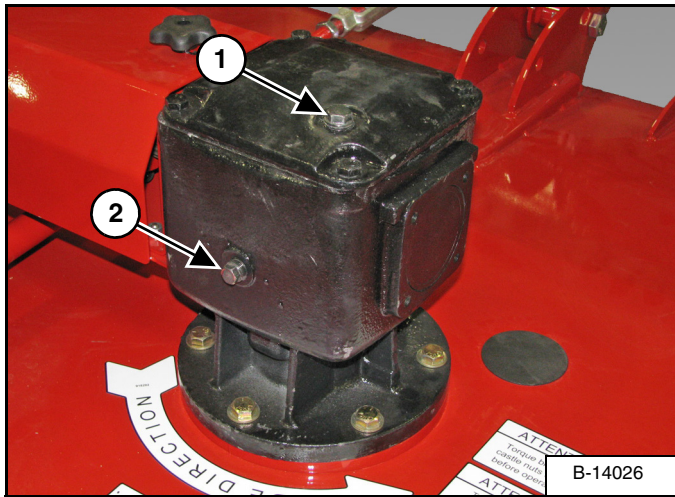

Remove dipstick / vent plug (Item 1) [Figure 39].
Place a collection container under the drain plug (Item 2) [Figure 39]. Remove drain plug and drain the gear oil into the collection container.

Once the oil is drained, install the drain plug.

Figure 40

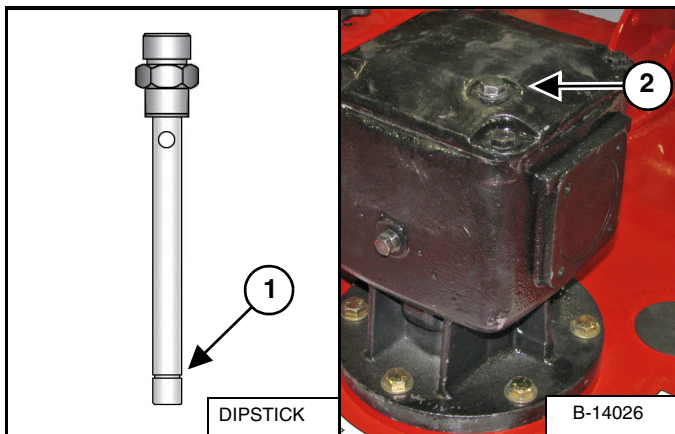

Add SAE 80W-90 gear oil until oil reaches the dipstick fill line (Item 1). Install and tighten dipstick / vent plug (Item 2) [Figure 40].

The gear oil level should be at the fill line (Item 1) [Figure 40].

Place the dipstick / vent plug (Item 2) [Figure 40] back into the splitter gearbox until the dipstick makes contact with the splitter gearbox. Pull dipstick out and check gear oil level.

Once gear oil reaches the fill line, install and tighten the dipstick / vent plug.

BLADES

Removal And Installation

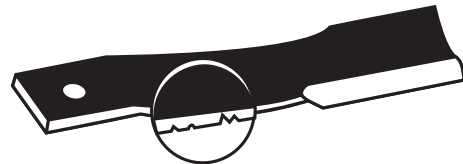

DAMAGED BLADES CAN CAUSE SERIOUS INJURY OR DEATH

- Inspect blades daily for chips, cracks, wear and abnormal bends.
- Do Not modify blades in any way such as sharpening, straightening or welding.
- Replace blades with genuine Farm King blades only.
- Unbalanced blades are dangerous.
- Replace blades in pairs.



- Inspect blades and blade hardware daily for tightness.
- Tighten blade mounting hardware to 765 ft-lb (1037 N•m) torque.
- Always install new blade mounting hardware every time blades are replaced.

Enter the tractor, start the engine and engage the tractor's hydraulics.

Run the tractor engine at low idle. Using the tractor's hydraulic controls, fully raise the deck.

Stop the tractor, engage the parking brake and turn the engine off.

Leave the operator's position. (See "Entering And Leaving The Operator's Position" on page 39.)

Figure 41

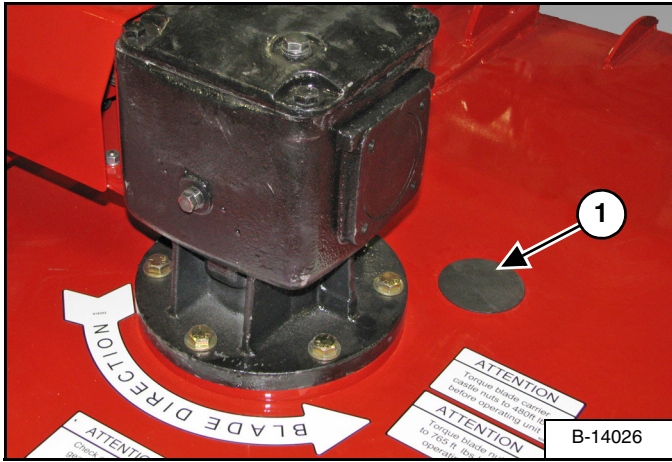

Remove access plug (Item 1) [Figure 41] from the deck (above blades to be replaced).

Figure 42

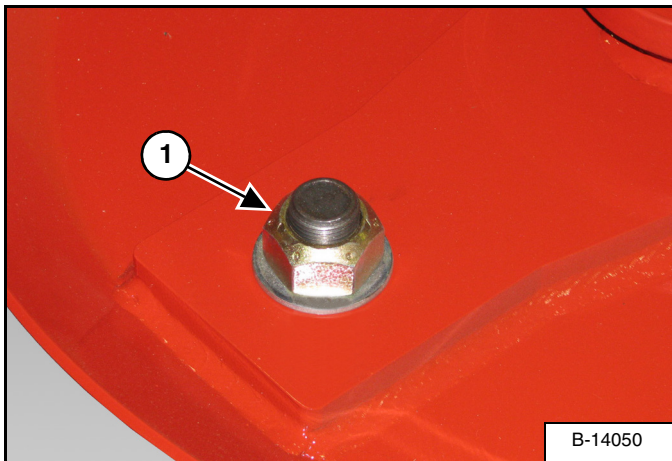

Rotate the blade pan until the desired blade hardware (Item 1) [Figure 42] is visible through the access hole in the deck.

Remove blade nut by placing wrench through the access hole of the deck. Remove blade bolt and blade.

Align new blade with the mounting hole. Using a hammer, tap the new blade bolt in place (flush against blade pan). Install a new blade nut and tighten to 765 ft-lb (1037 N•m) torque.

Repeat as needed until the desired blades have been replaced.

BLADE PAN

Removal And Installation

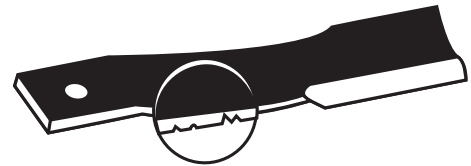

DAMAGED BLADES CAN CAUSE SERIOUS INJURY OR DEATH

- Inspect blades daily for chips, cracks, wear and abnormal bends.
- Do Not modify blades in any way such as sharpening, straightening or welding.
- Replace blades with genuine Farm King blades only.
- Unbalanced blades are dangerous.
- Replace blades in pairs.



- Inspect blades and blade hardware daily for tightness.
- Tighten blade mounting hardware to 765 ft-lb (1037 N•m) torque.
- Always install new blade mounting hardware every time blades are replaced.

Enter the tractor, start the engine and engage the tractor's hydraulics.

Run the tractor engine at low idle. Using the tractor's hydraulic controls, fully raise the deck.

Stop the tractor, engage the parking brake and turn the engine off.

Leave the operator's position. (See "Entering And Leaving The Operator's Position" on page 39.)

Figure 43

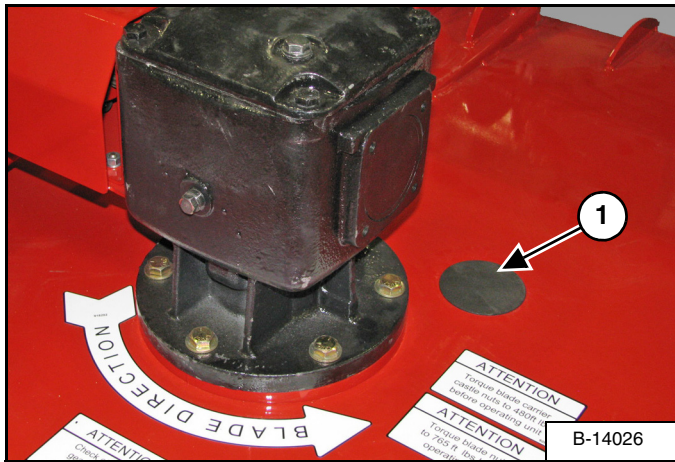

Remove access plug (Item 1) [Figure 43] from the deck (above blades to be replaced).

Figure 44

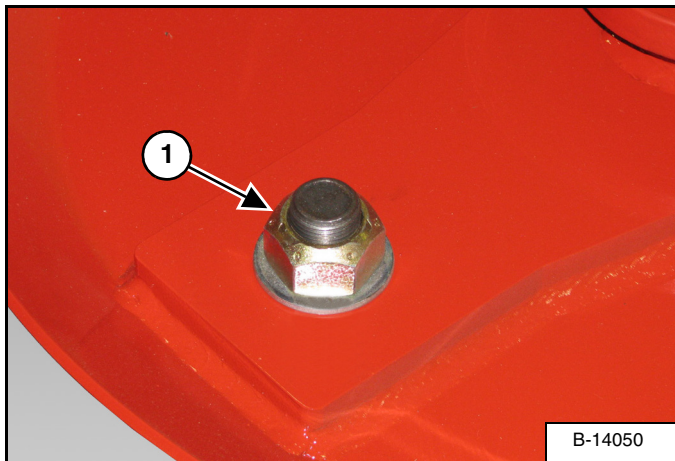

Rotate the blade pan until the desired blade hardware (Item 1) [Figure 44] is visible through the access hole in the deck.

Remove one blade nut by placing wrench through the access hole of the deck. Remove blade bolt and blade.

Rotate blade pan the align second blade hardware.

Remove second blade nut, bolt and blade.

Figure 45

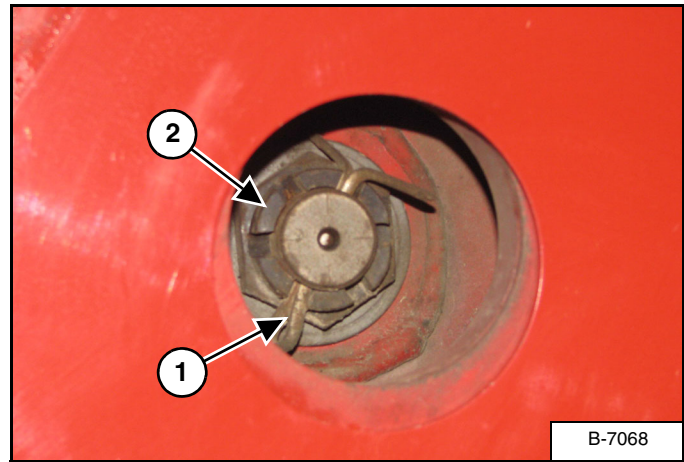

Remove cotter pin (Item 1) and castle nut (Item 2) [Figure 45]. Remove blade pan.

Align new blade pan with the gearbox shaft.

Install castle nut (Item 2) [Figure 45]. Tighten castle nut to 800 ft. lb. (1080 N•m) torque.

Install cotter pin (Item 1) [Figure 45].

Align one new blade with the mounting hole. Using a hammer, tap the new blade bolt in place (flush against blade pan). Install a new blade nut and tighten to 765 ft-lb (1037 N•m) torque.

Rotate blade pan to align second blade hardware.

Align second new blade with the mounting hole. Using a hammer, tap the new blade bolt in place (flush against blade pan). Install a new blade nut and tighten to 765 ft-lb (1037 N•m) torque.

AXLE

Wheel Bolts Torque

Check the torque on wheel bolts daily. Tighten wheel bolts to 93 ft. lb. (126 N•m) torque.

Tire / Wheel Replacement



AVOID INJURY OR DEATH

Before you leave the operator’s position:

- Always park on a flat level surface.
- Place all controls in NEUTRAL.
- Engage the park brake.
- Stop the engine and remove the key.
- Wait for all moving parts to stop.

Park the tractor / equipment on a flat level surface.

Place all controls in neutral, engage the park brake, stop the engine and wait for all moving parts to stop. Leave the operator’s position.



AVOID INJURY OR DEATH

- The parking brake must be engaged before leaving the operator’s position. Rollaway can occur because the transmission may not prevent machine movement.
- Always chock tires before performing any maintenance or service.

Place chock blocks behind and in front of the opposite tire to be removed.

Place a jack under the axle frame close to the tire / wheel being replaced. Raise the jack until the tire / wheel is slightly off the ground.

NOTE: Place blocks under the frame to help secure the Rotary Cutter when tire / wheel is raised off the ground.

Remove the five wheel nuts and remove the tire / wheel.

Figure 46

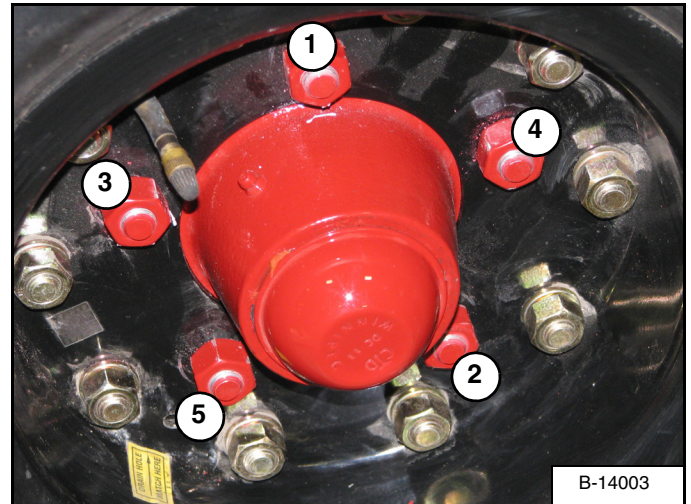

Install the five wheel nuts (Items 1 - 5) [Figure 46]. Tighten wheel bolts in a criss-cross pattern [Figure 46]. Tighten wheel bolts to 93 ft. lb. (126 N•m) of torque.

Wheel Bearings

Inspect and re-pack the wheel bearings annually with a quality SAE multi purpose type grease.

Tire Pressure (Aircraft Type)



When inflating tires, use a clip-on chuck and extension hose long enough to allow you to stand to one side and NOT in front of or over the tire assembly.

Check tire pressure daily. Fill tires to 40 psi (276 kPa).

CLEANING THE ROTARY CUTTER

Fully Clean the Rotary Cutter DAILY:

 **IMPORTANT****AVOID COMPONENT DAMAGE**

- Remove all debris around and under the PTO drivelines.
 - Remove all debris around the gearboxes, blade pans and blades.
-

SAFETY SIGN (DECAL) INSTALLATION**Procedure** **IMPORTANT**

When replacing safety signs (decals), the temperature must be above 10° C (50° F).

- Remove all portions of the damaged safety sign (decal).
- Thoroughly clean the area with glass cleaner. Remove all adhesive residue.
- Allow the area to dry completely before installing the new safety sign (decal).
- Position the safety sign (decal) in the correct location. Remove a small portion of the backing paper on the safety sign (decal).
- Press on the safety sign (decal) where the backing paper has been removed.
- Slowly remove the remaining backing paper, pressing on the safety sign (decal) as the backing paper is removed.
- Using the backing paper, pressing firmly, move the backing paper over the entire safety sign (decal) area.

NOTE: Small air pockets can be pierced with a pin and smoothed out using the piece of the backing paper.

STORAGE AND RETURN TO SERVICE

Storage

Sometimes it may be necessary to store your Farm King Rotary Cutter for an extended period of time. Below is a list of items to perform before storage.



DO NOT permit children to play on or around the stored machine.

- Thoroughly clean the equipment.
- Lubricate the equipment.
- Inspect the hitch and all welds on the equipment for wear and damage.
- Check for loose hardware, missing guards, or damaged parts.
- Check for damaged or missing safety signs (decals). Replace if necessary.
- Replace worn or damaged parts.
- Touch up all paint nicks and scratches to prevent rusting.
- Store the Rotary Cutter in a clean, dry, sheltered area.
- Place the equipment flat on the ground.

Return To Service

After the Farm King Rotary Cutter has been in storage, it is necessary to follow a list of items to return the equipment to service.

- Be sure all shields and guards are in place.
- Lubricate the equipment.
- Inspect and repack wheel bearings with a SAE multi purpose type grease.
- Check that tires / wheels are in good operating condition and wheel nuts are tightened to the proper torque.
- Connect to a tractor and operate equipment, verify all functions operate correctly.
- Check for leaks. Repair as needed.
- Review the Operator's Manual.

Farm King



PARTS IDENTIFICATION

GENERAL INFORMATION71

 3-Point Hitch Assembly72

 3-Point Tail Wheels74

 Pull Type Hitch Assembly76

 3-Point Tire Assembly78

 Pull Type Tire Assembly80

 Gearbox / Blade Assembly82

 Chain Guarding Assembly84

 Pan And Blade Assembly86

 Spindle Assembly87

 540 RPM Driveline (F2116)88

 540 RPM Shaft (F2118)89

Farm King



GENERAL INFORMATION

The parts identification section lists descriptions, part numbers and quantities for the 8' Rotary Cutter. Contact your Farm King dealer for additional 8' Rotary Cutter parts information.

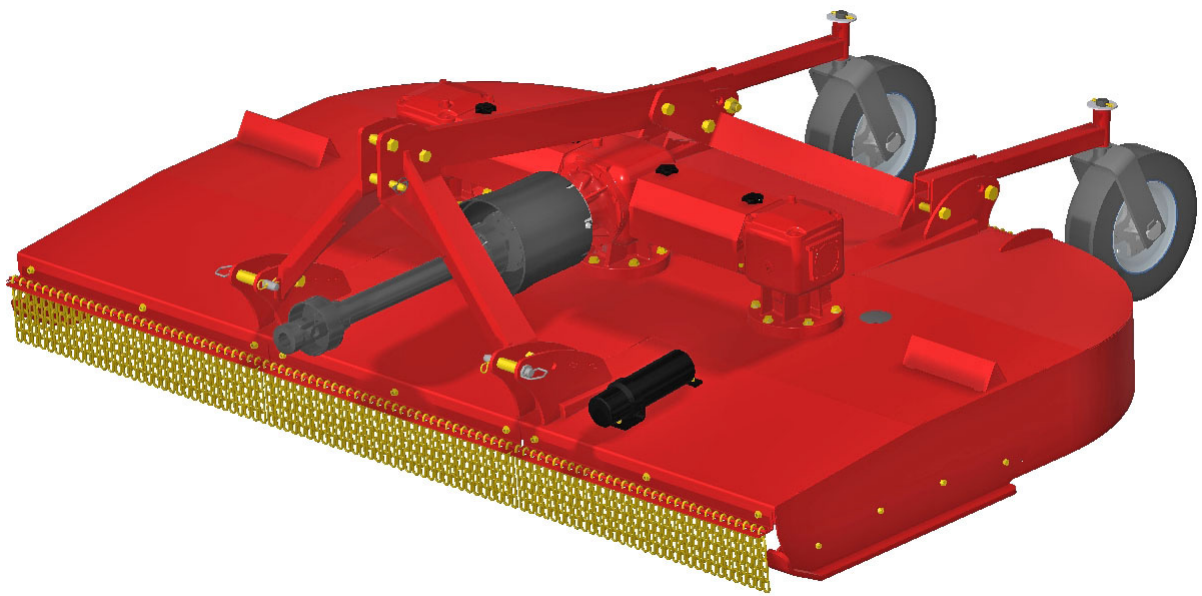

3-Point Hitch Assembly

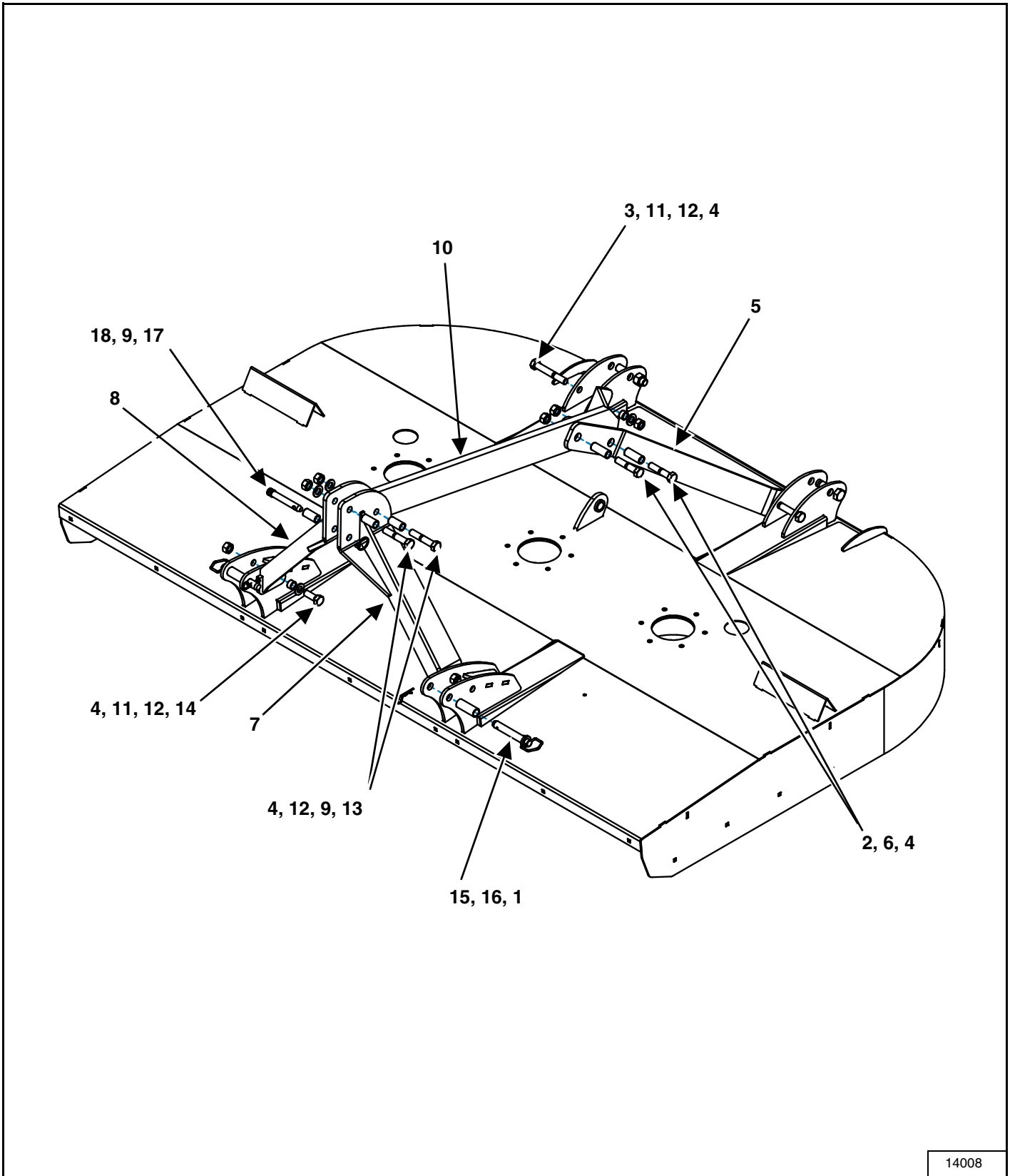

14008

ITEM	PART NUMBER	DESCRIPTION	QTY
1	12779	HAIR PIN CLIP #9	2
2	810149	3/4" x 3-1/2" HEX BOLT (PL)	2
3	811751	3/4" x 5" HEX BOLT (PL)	2
4	812365	3/4" LOCKNUT	8
5	818010	PLATE, REAR HITCH BRACE	2
6	818406	BUSHING, 1.000" OD x 0.782" ID	2
7	818544	WELDMENT, TOP LINK MOUNT RHS	1
8	818545	WELDMENT, TOP LINK MOUNT RHS	1
9	818546	BUSHING, 1.000" OD x 0.782" ID x 2.00"	3
10	818596	BAR - TOP LINKAGE	1
11	818612	BUSHING, 3 PT LINKAGE PIVOT (PL)	4
12	84050	3/4" S.A.E. FLAT WASHER (PL)	6
13	84336	3/4" X 4" HEX BOLT (PL)	2
14	84467	3/4" X 2" HEX BOLT (PL)	2
15	907315	84" HITCH PIN	2
16	907316	PIN SLEEVE 7/64" W X 1 1/8" X 2 7/8"	2
17	965807	CAT. 1 TOP LINK PIN	1
18	965911	LINCH PIN 7/16	1

3-Point Tail Wheels

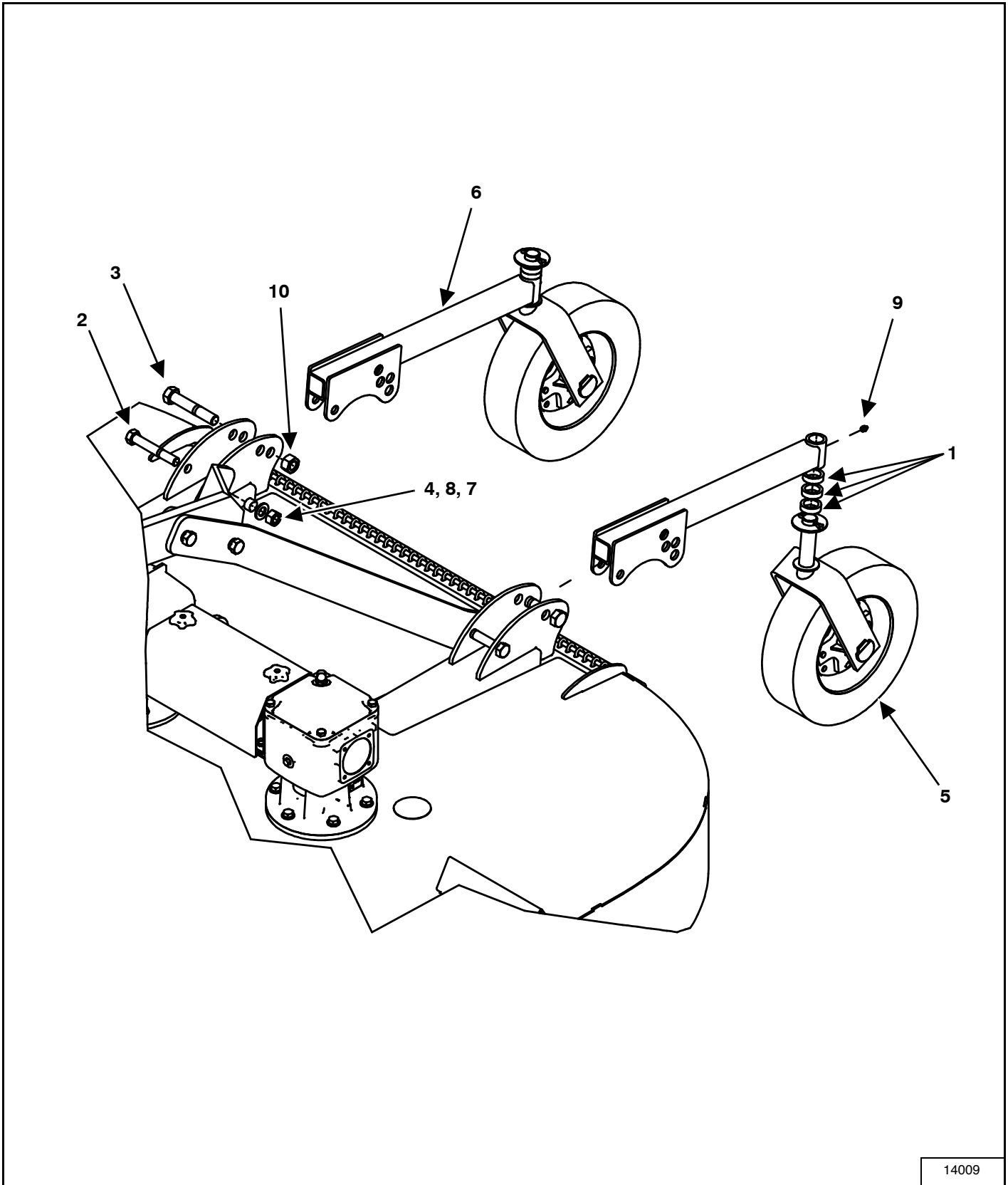

ITEM	PART NUMBER	DESCRIPTION	QTY
1	116786	SPACER 1.2610, TA1LWHEEL 4'RC/S'RC	6
2	811751	3/4" x 5" HEX BOLT (PL)	2
3	811826	7/8" x 5" HEX BOLT (PL)	2
4	812365	3/4" LOCK NUT (PL)	2
5	814432	WHEEL TAIL 15"	2
6	818594	WELDMENT, TAIL WHEEL MOUNT	2
7	818612	BUSHING, 3 PT LINKAGE PIVOT (PL)	2
8	84050	3/4" S.A.E. FLAT WASHER (PL)	2
9	84583	SCREW IN GREASE FITTING	2
10	907674	7/8" LOCK NUT	2

Pull Type Hitch Assembly

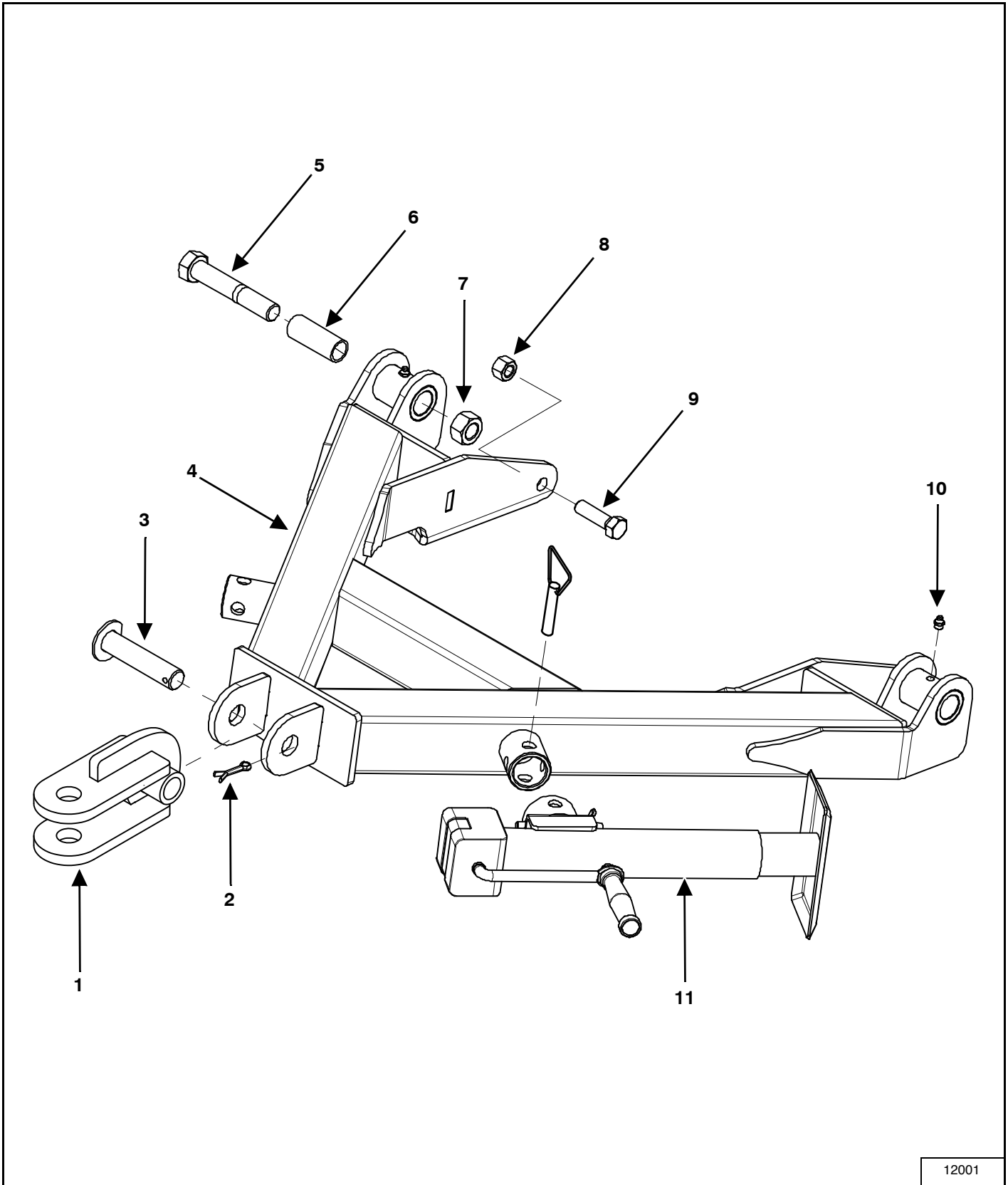

12001

ITEM	PART NUMBER	DESCRIPTION	QTY
1	818823	WELDMENT, CAT II SWIVEL CLEVIS	1
2	9812434	COTTER PIN, 1/4" x 1-1/2" (PL)	1
3	966531	CLEVIS PIN, RC	1
4	818338	TRAILER HITCH WELDMENT	1
5	811826	BOLT, 7/8" x 5" HEX (PL)	2
6	907316	PIN SLEEVE, 7/64" W x 1-1/8" x 2-7/8"	2
7	907674	LOCK NUT, 7/8"	2
8	812482	LOCK NUT, 5/8" (PL)	2
9	967122	BOLT, 5/8" x 2-1/4" HEX GR 8 (PL)	2
10	84583	SCREW IN GREASE FITTING	2
11	921284	JACK, 5000LB CAP SIDE CRANK	1

3-Point Tire Assembly

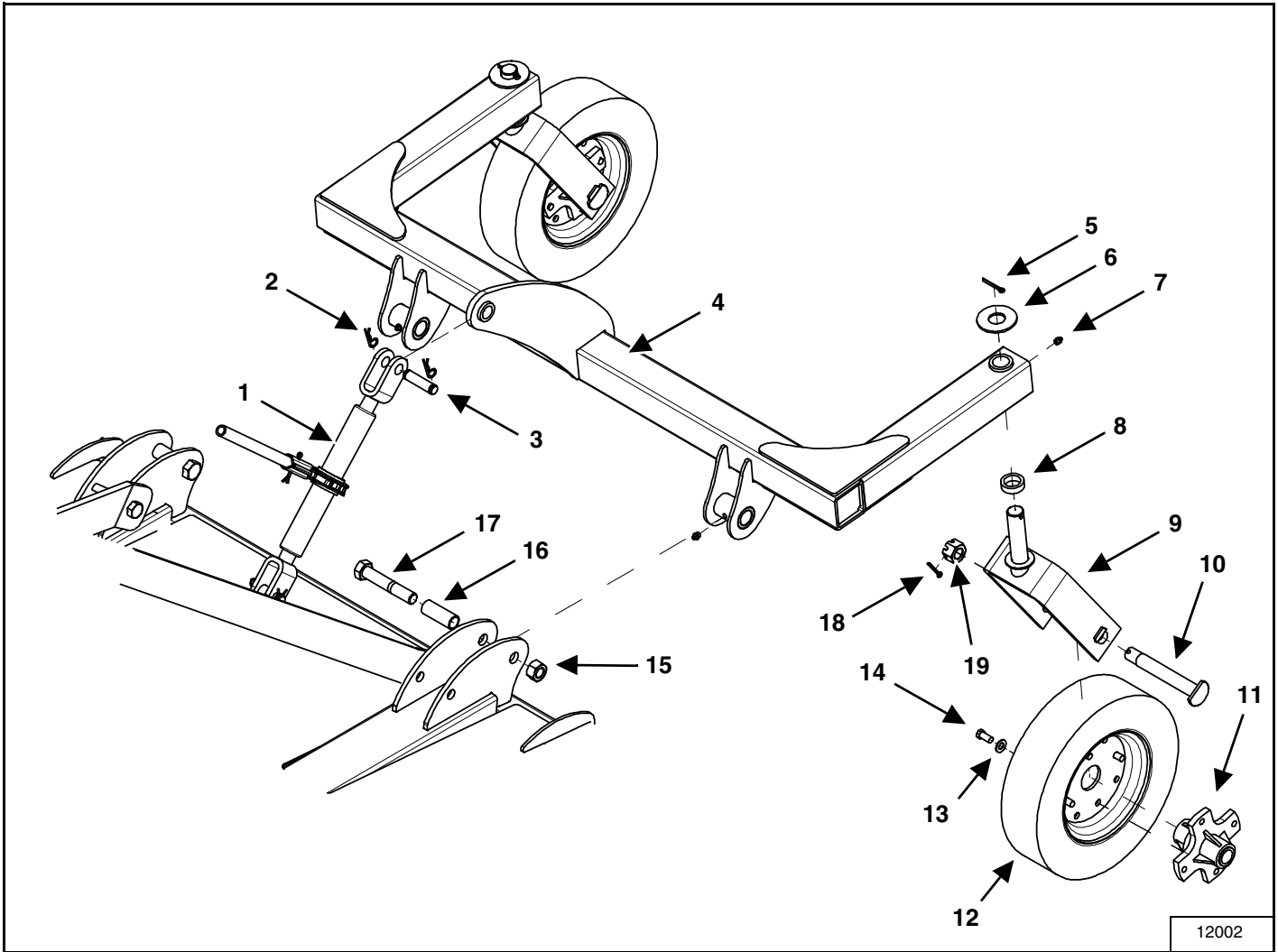

ITEM	PART NUMBER	DESCRIPTION	QTY
1	967499	RATCHET JACK, C/W HARDWARE & HANDLE	1
2	12779	HAIRPIN CLIP, #9	4
3	103753	CLEVIS PIN, 1" x 4" (OPTIONAL)	2
4	818005	TAIL WHEEL ARM WELDMENT	1
5	81210	COTTER PIN, 1/4" x 2" ZNPL	2
6	967110	TAIL WHEEL WASHER, 1-1/4" ID x 4 MM	2
7	84583	SCREW IN GREASE FITTING	2
8	116786	TAIL WHEEL SPACER, 1.26" ID x 4' RC/5' RC (OPTIONAL)	2
9	909767	WHEEL YOKE SERI RC	2
10	909768	SPINDLE BOLT SERI RC	2
11	909772	HUB W/ BUSH RC	2
12	909771	15" SOLID WHEEL & RIM	2
13	909774	HUB FLAT WASHER	8
14	909773	HUB BOLT, M12 HEX	8
15	907674	LOCK NUT, 7/8"	2
16	907316	PIN SLEEVE, 7/64" W x 1-1/8" x 2-7/8"	2
17	811826	BOLT, 7/8" x 5" HEX	2
18	909770	COTTER PIN, 1/4" x 2" ZNPL	2
19	909769	SLOTTED HEX NUT	2

Pull Type Tire Assembly

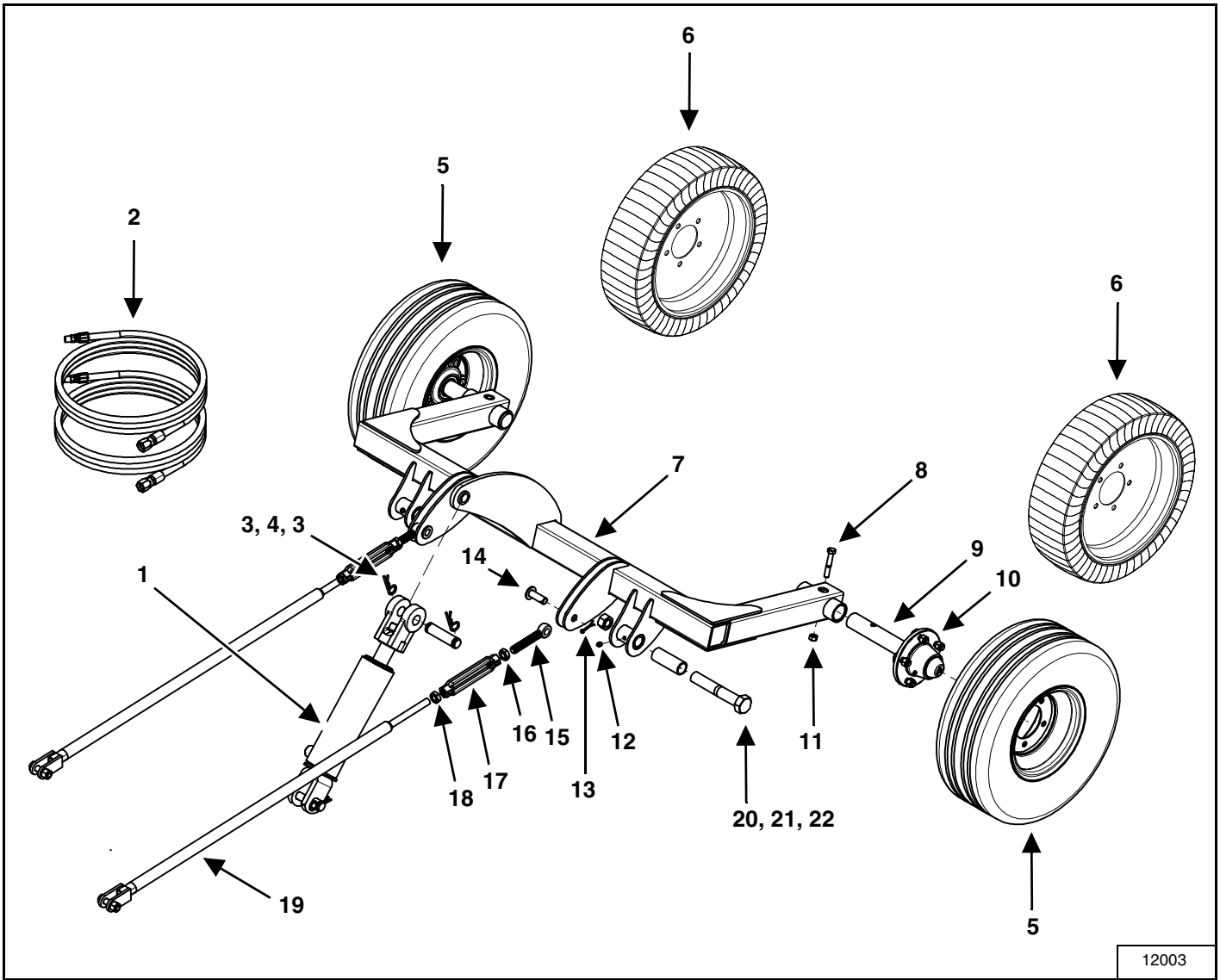

ITEM	PART NUMBER	DESCRIPTION	QTY
1	24791M	CYLINDER, 3" DIA x 8" (OPTIONAL)	1
2	114905	HOSE, 1/2" x 144" (1/2" MNPT x 3/4" MORB)	2
3	12779	HAIRPIN CLIP #9	4
4	103753	CLEVIS PIN 1" x 4" (OPTIONAL)	2
5	F1990	AIRCRAFT TIRE ASSEMBLY (OPTIONAL)	2
6	F1989	LAMINATED WHEEL ASSEMBLY (OPTIONAL)	2
7	818003	TRAILING ARM WELDMENT	1
8	81627	BOLT, 1/2" x 3" HEX (PL)	2
9	915668	REMOVABLE SINGLE SPINDLE SHAFT	2
10	915679	HUB, HA517	2
11	812364	LOCK NUT, 1/2" (PL)	2
12	84583	SCREW IN GREASE FITTING	2
13	9812433	COTTER PIN, 3/16" x 1-1/2"	2
14	966524	CONTROL ROD PIN	2
15	818057	C1035 ROD END, 3/4" - 5" LENGTH	2
16	86111	JAM NUT, 3/4" HEX (PL)	2
17	818059	TURNBUCKLE, 3/4" x 6" UNC	2
18	818061	JAM NUT - 3/4" UNCH LEFT HAND	2
19	818054	LEVEL ROD WELDMENT, RCZ	2
20	811826	BOLT, 7/8" x 5" HEX (PL)	2
21	907316	PIN SLEEVE, 7/64" - 1-1/8" x 2-7/8"	2
22	907674	LOCK NUT, 7/8"	2

Gearbox / Blade Assembly

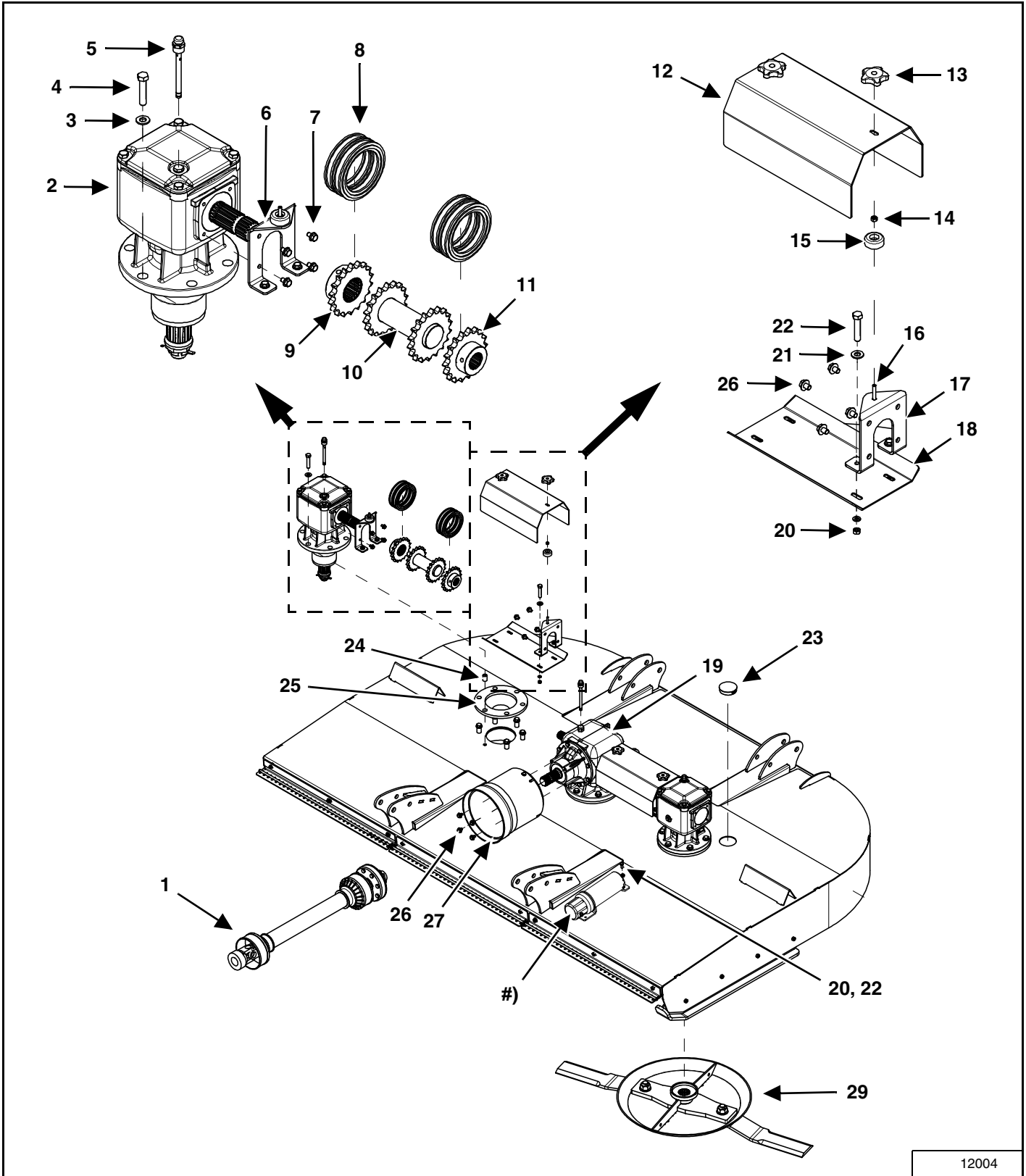

12004

ITEM	PART NUMBER	DESCRIPTION	QTY
1	F2118	PTO DRIVELINE (8' CUTTER - TRAILING)	1
	F2116	PTO DRIVELINE (8' CUTTER - 3 PT)	1
2	924583	GEARBOX, RATIO 1:1.22	2
3	84048	FLAT WASHER, 1/2" SAE (PL)	18
4	811796	BOLT, 1/2" x 2-1/2" HEX GR 5 (PL)	18
5	925178	VENT PLUG, 1/2" GAS OIL FILLER LEVEL	2
6	818012	SHIELD MOUNT PLATE	2
7	818062	BOLT, M 8-1-14" x 12 MM FLANGE	8
8	818327	#60 DOUBLE ROLLER CHAIN, 18 LINKS	4
9	818326	SPROCKET WELDMENT, 18T, 1-3/4" Z21 BORE, #60 CHAIN	2
10	818542	OUTBOARD DRIVESHAFT WELDMENT	2
11	818325	SPROCKET WELDMENT, 18T, 1-3/8" Z21 BORE, #60 CHAIN	2
12	818013	OUTBOARD SHAFT SHIELD PLATE	2
13	920986	KNOB, 2-1/4" DIA THROUGH HOLE	4
14	84498	LOCK NUT, 1/4" (PL)	4
15	920985	BUMPER, 1-1/2" DIA W/WASHER	4
16	920988	FULL CARRIAGE BOLT, 1/4" NC x 1-1/2" GR 5 (PL)	4
17	818064	SPLITTER SHIELD MOUNT PLATE	2
18	818835	PLATE, LOWER SHIELD	2
19	818079	8' TWIN SPINDLE SPLITTER GEARBOX	1
20	812362	LOCKNUT, 5/16" (PL)	10
21	81546	FLAT WASHER, 5/16" (PL)	8
22	81549	BOLT, 5/16" x 3/4" HEX (PL)	10
23	918201	HOLE PLUG, 3" DIA x 1/4" THICK	2
24	818058	GEARBOX BOLT INSERT BUSHING	18
25	818317	GEARBOX MOUNT PLATE	3
26	818063	BOLT, M 10-1-1/2" x 12 MM FLANGE	12
27	925182	SAFETY CONE GUARD, W/FLANGE	1
28	909277	MANUAL HOLDER, 3-1/2" x 12"	1
29	-	COMPLETE BLADE ASSEMBLY	2

Chain Guarding Assembly And Skid Shoe Assembly

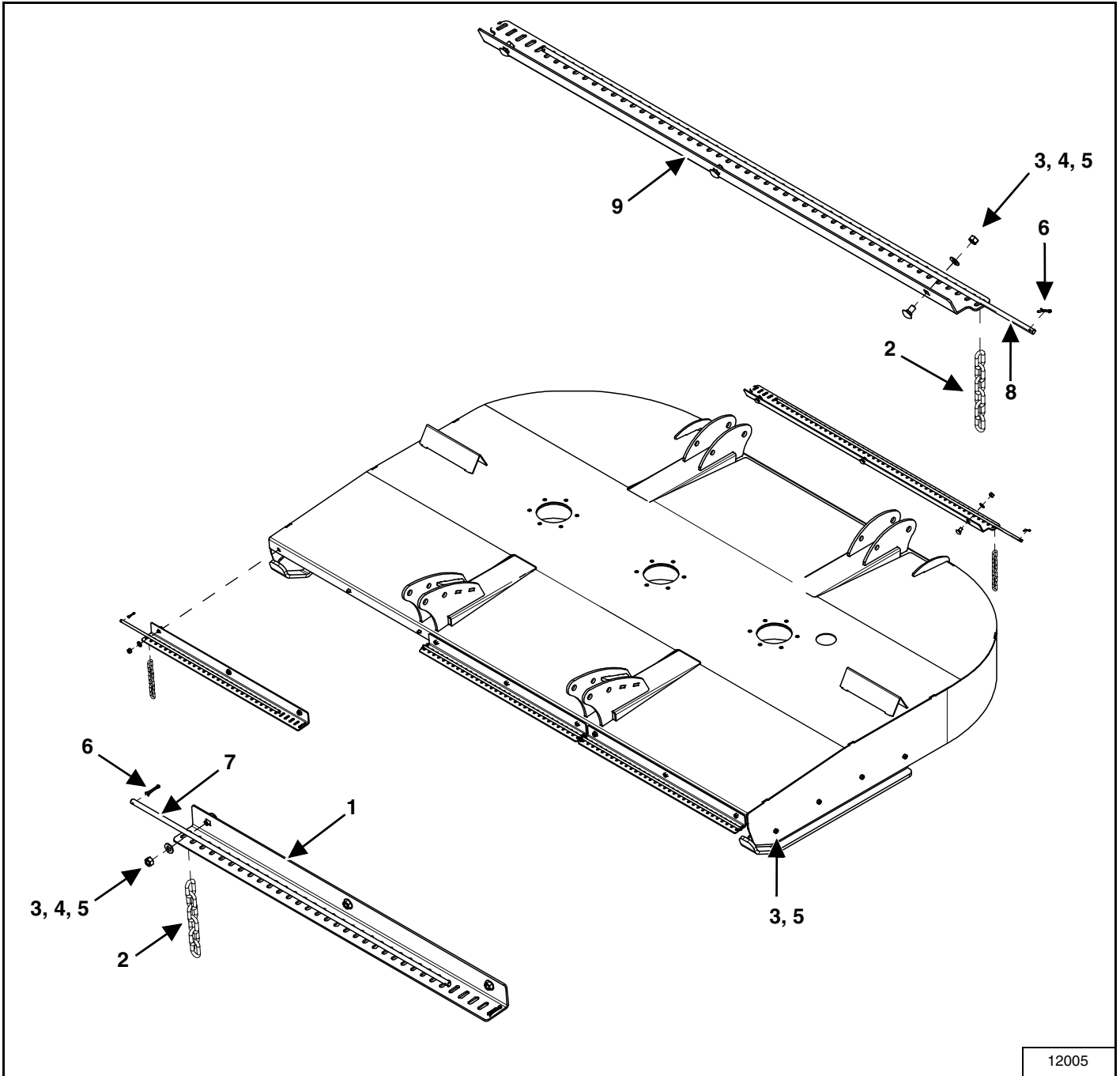

ITEM	PART NUMBER	DESCRIPTION	QTY
1	818192	FRONT CHAIN GUARD MOUNT PLATE	3
2	966591	CHAIN LINK, 1/4" x 6"	154
3	812363	LOCK NUT, 3/8" (PL)	20
4	84039	FLAT WASHER, 3/8" (PL)	12
5	81914	CARRIAGE BOLT, 3/8" x 1" (PL)	20
6	9812430	COTTER PIN, 1/8" x 1" (PL)	8
7	818193	FRONT CHAIN ROD	3
8	818044	REAR MIDDLE CHAIN ROD	1
9	818043	REAR CHAIN GUARD MOUNT PLATE	1

Pan And Blade Assembly

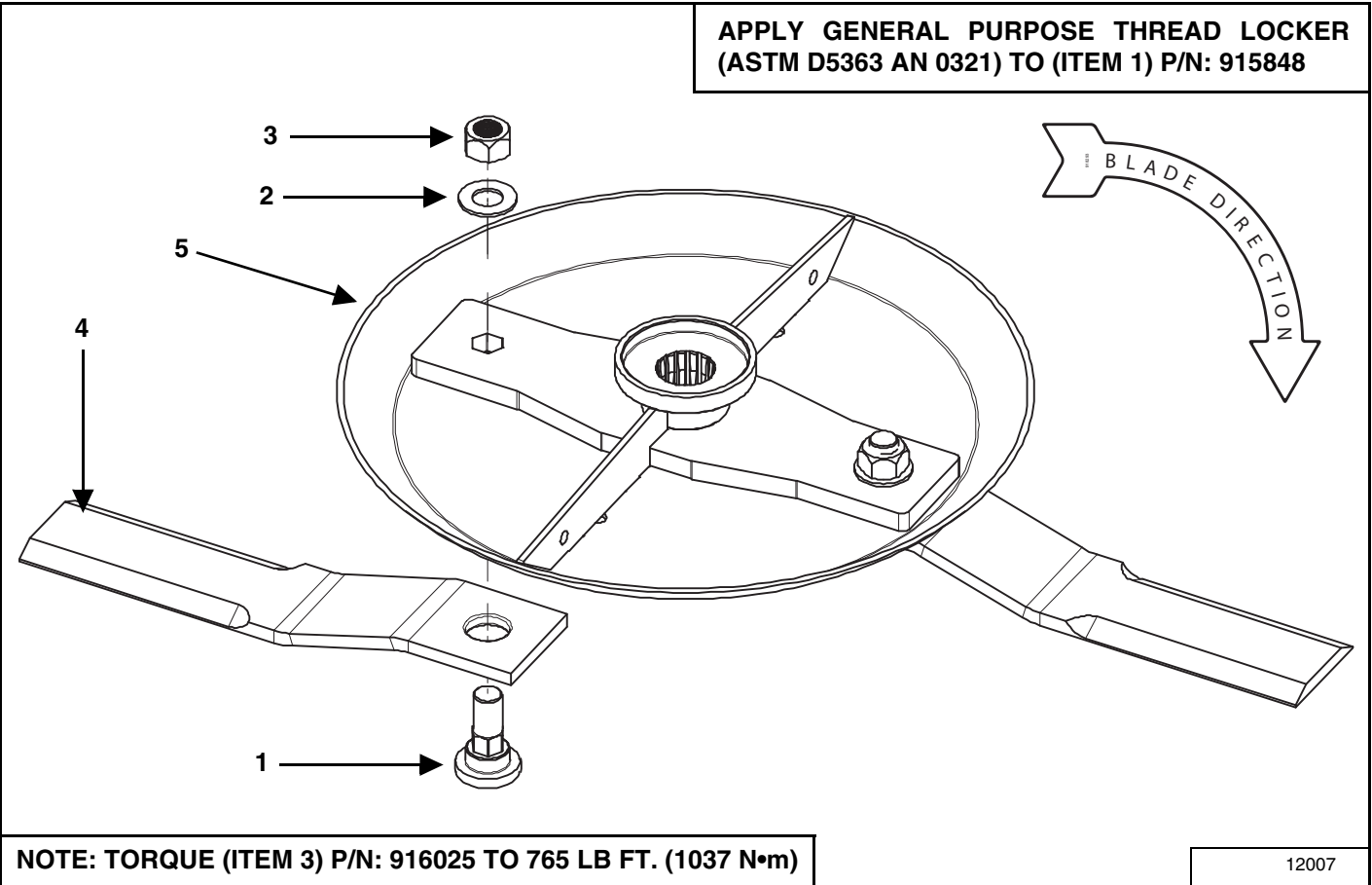

ITEM	PART NUMBER	DESCRIPTION	QTY
1	915848	BLADE HOLE SHOULDER BOLT, 1-1/2" HEX	4
2	84522	FLAT WASHER, 1" ID SAE (PL)	4
3	916025	NUT, 1-14 UNS DEFORMED THREAD	4
4	818000	8' RC TWIN SPINDLE BLADE - 19-1/4"	4
5	818007	8' RC STUMP JUMPER WELDMENT	2

Spindle Assembly

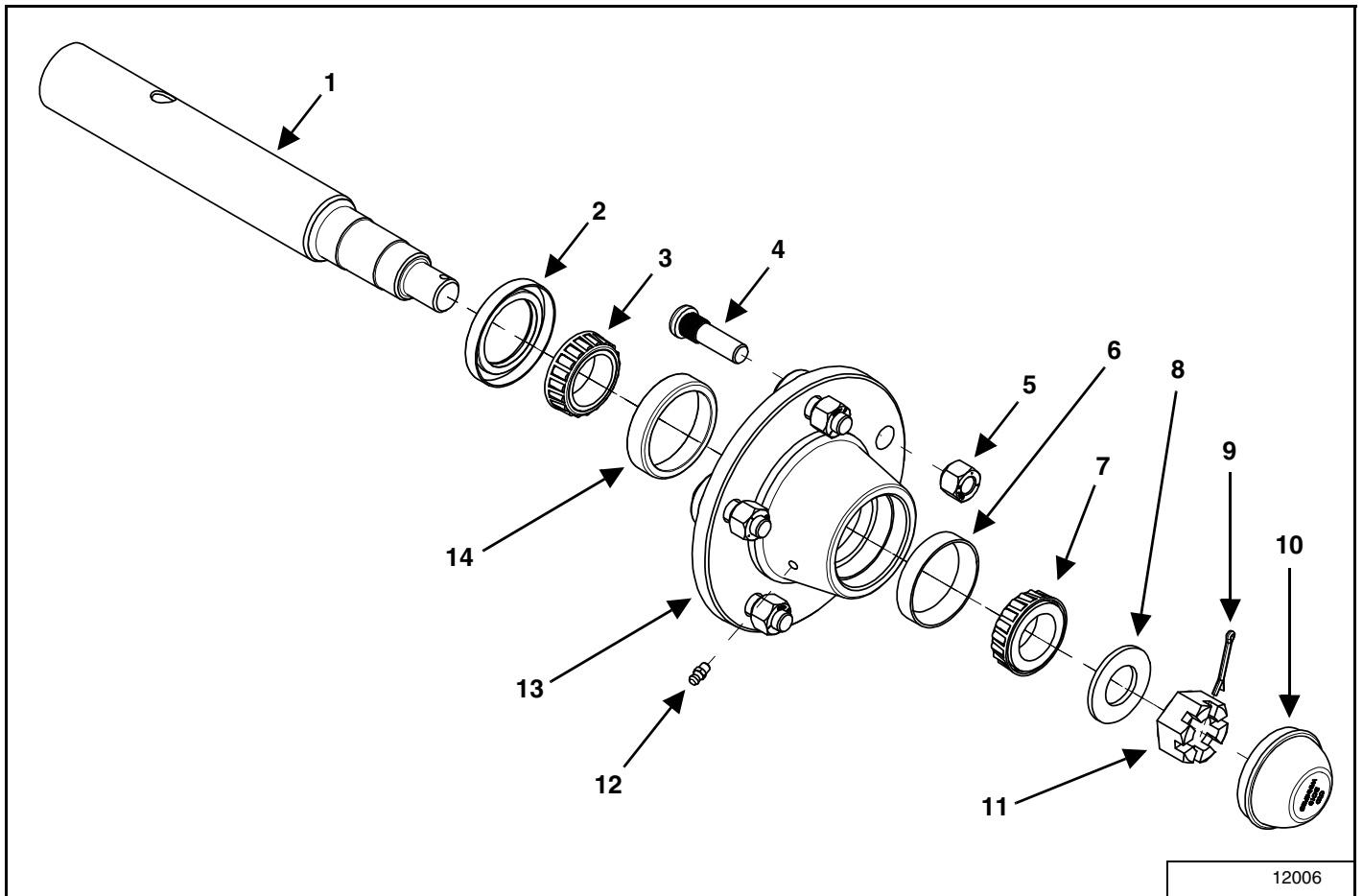

ITEM	PART NUMBER	DESCRIPTION	QTY
1	915668	REMOVABLE SINGLE SPINDLE SHAFT	2
2	967707	OIL SEAL, SE13	2
3	967208	INNER BEARING CONE, 967208 (LM48548)	2
4	919309	WHEEL BOLT, WB16	10
5	915665	WHEEL STUD NUT, WB11	10
6	967711	OUTER BEARING CUP, (LM67010)	2
7	967712	INNER BEARING CONE, (LM67048)	2
8	967713	FLAT WASHER, 7/8" SAE (BR)	2
9	9812486	COTTER PIN, 1/8" x 1-1/2" (BR)	2
10	967716	DUST CAP, DC13	2
11	810010	SLOTTED NUT, 7/8" UNF (BR)	2
12	967900	GREASE FITTING, 1/4"	2
13	919312	HUB, 517-2	2
14	968412	INNER CUP, (LM48510)	2

540 RPM Driveline (F2116)

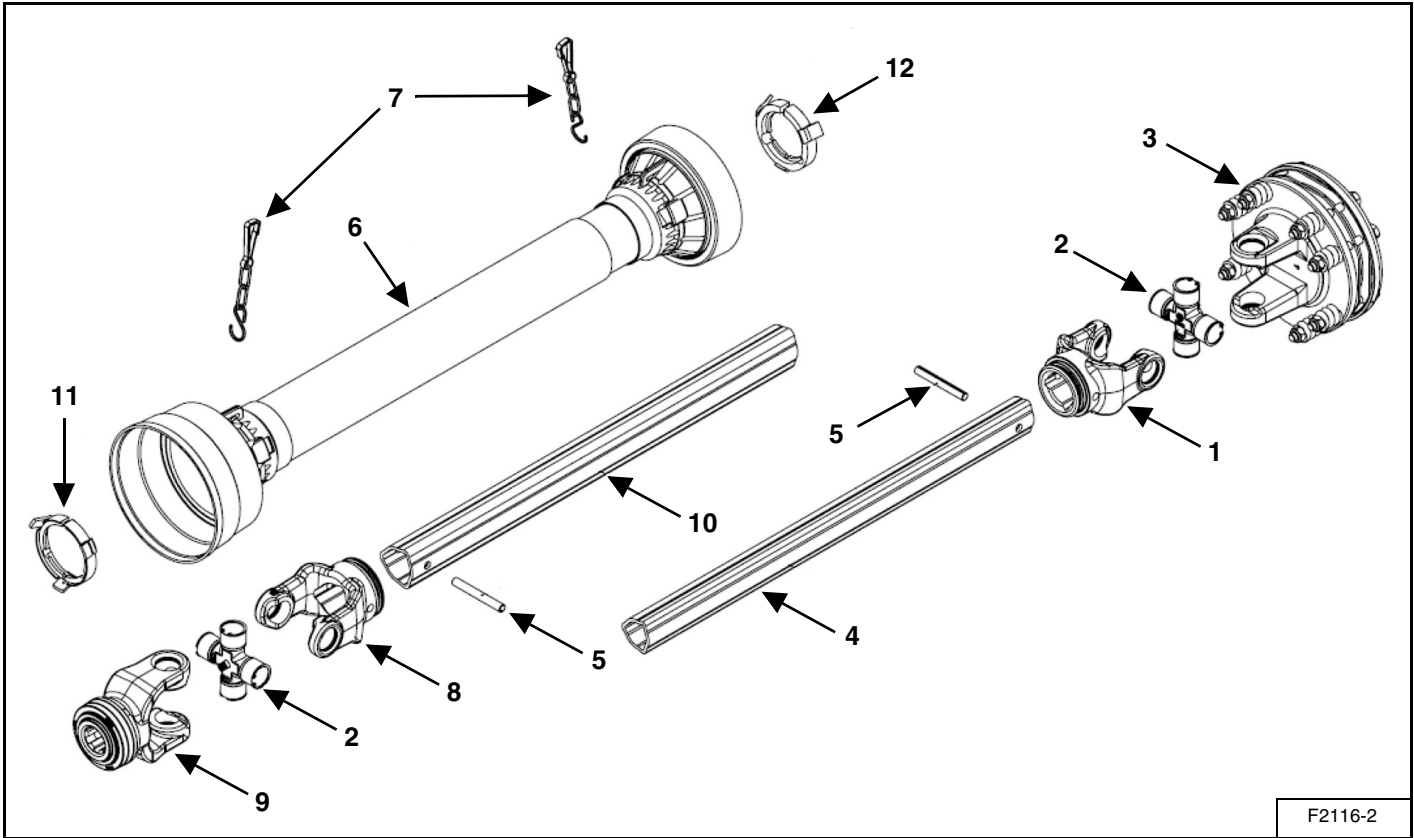

F2116-2

ITEM	PART NUMBER	DESCRIPTION	QTY
1	925308	INBOARD YOKE FOR INNER TUBE	1
2	925293	CROSS KIT WITH GREASE	2
3	818566	FRICTION CLUTCH -1350 N•m	1
4	818567	TRIANGULAR TUBE L=645	1
5	925360	ELASTIC PIN	2
6	818569	SHAFT SHIELD	1
7	817774	CHAIN	2
8	925340	INBOARD YOKE FOR OUTER TUBE	1
9	817804	YOKE WITH QL BALL TYPE	1
10	818573	TRIANGULAR TUBE L=645	1
11	817809	RETAINER	1
12	817808	RETAINER	1

540 RPM Shaft (F2118)

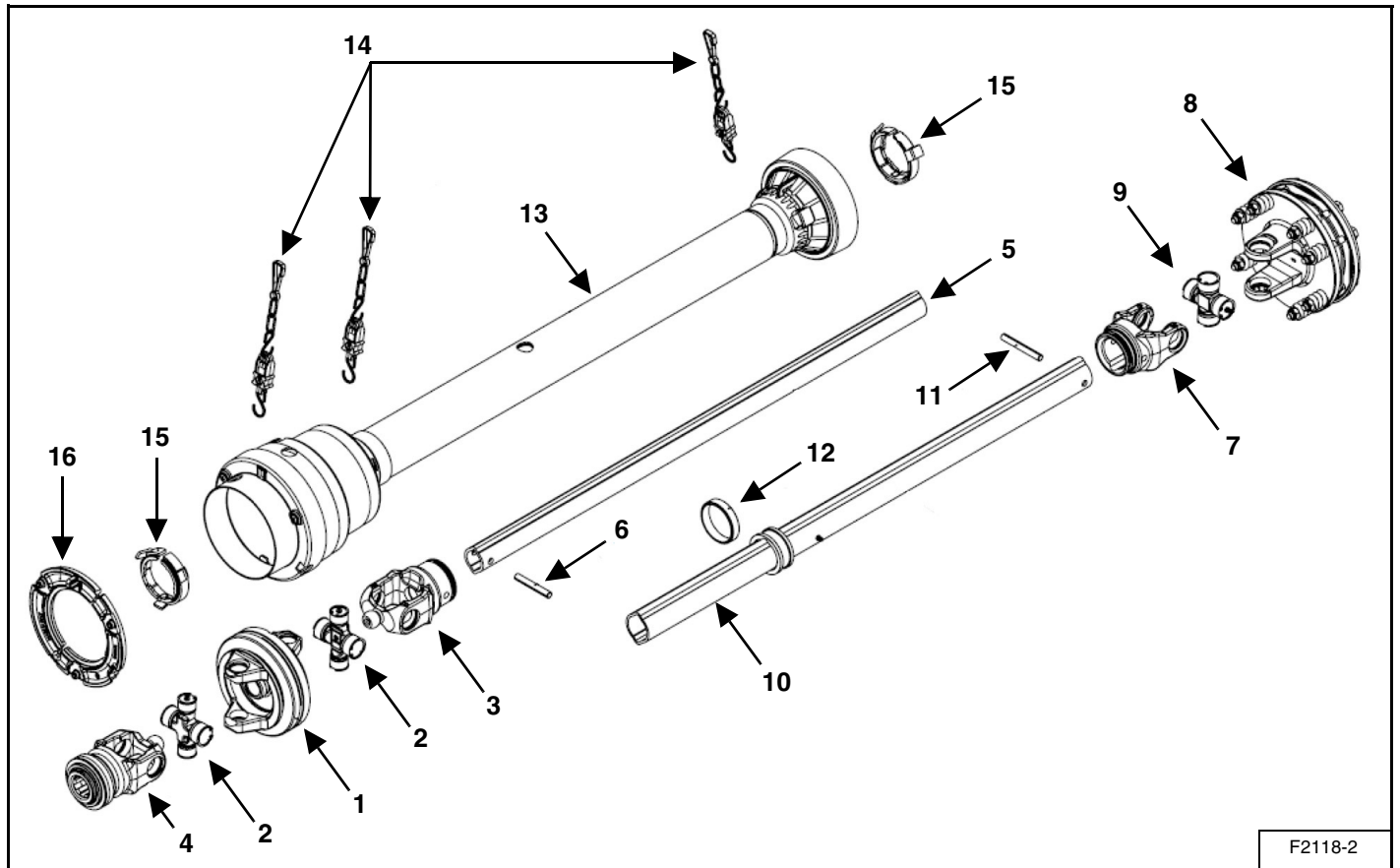

F2118-2

ITEM	PART NUMBER	DESCRIPTION	QTY
1	925366	CV WIDE ANGLE 80 DEG	1
2	925355	CROSS W/ GREASE NPPL ON	2
3	818603	CV WIDE ANGLE INBOARD YOKE FOR INNER TUBE	1
4	818604	CV WIDE ANGLE YOKE WITH QL BALL TYPE	1
5	818605	RILSAN LEMON TUBE L=945	1
6	925358	ELASTIC PIN 10 MM x 70 MM	1
7	818606	INBOARD YOKE FOR OUTER TUBE	1
8	818607	FRICTION CLUTCHES 4 PLATE HP TYPE-F4	1
9	925353	CROSS W/ GREASE NPPL ON BRG CUP	1
10	818608	LEMON TUBE L=945 WITH GREASE NIPPLES, ANTI-VIBRATING SLEEVE	1
11	925360	ELASTIC PIN 10 MM x 80 MM	1
12	818578	RING FOR ANTI-VIBRATING SLEEVE	1
13	818609	WIDE ANGLE SHAFT SHIELD	1
14	925361	PRE DISENGAGEMENT SYSTEM CHAIN	3
15	818610	RETAINER	2
16	925342	WIDE ANGLE RETAINER	1

Farm King



SPECIFICATIONS

SPECIFICATIONS93
 3-Point Model Dimensions93
 Performance93
 Pull Type Model Dimensions94
 Performance94

HARDWARE TORQUE VALUES95
 Metric Chart95
 Imperial Chart96

HYDRAULIC CONNECTION SPECIFICATIONS97
 O-Ring Fitting (Straight Thread)97
 O-ring Face Seal Connection97
 Flare Fitting97
 Port Seal (O-ring Boss) Fitting97
 Tubelines And Hoses97

Farm King



SPECIFICATIONS

3-Point Model Dimensions

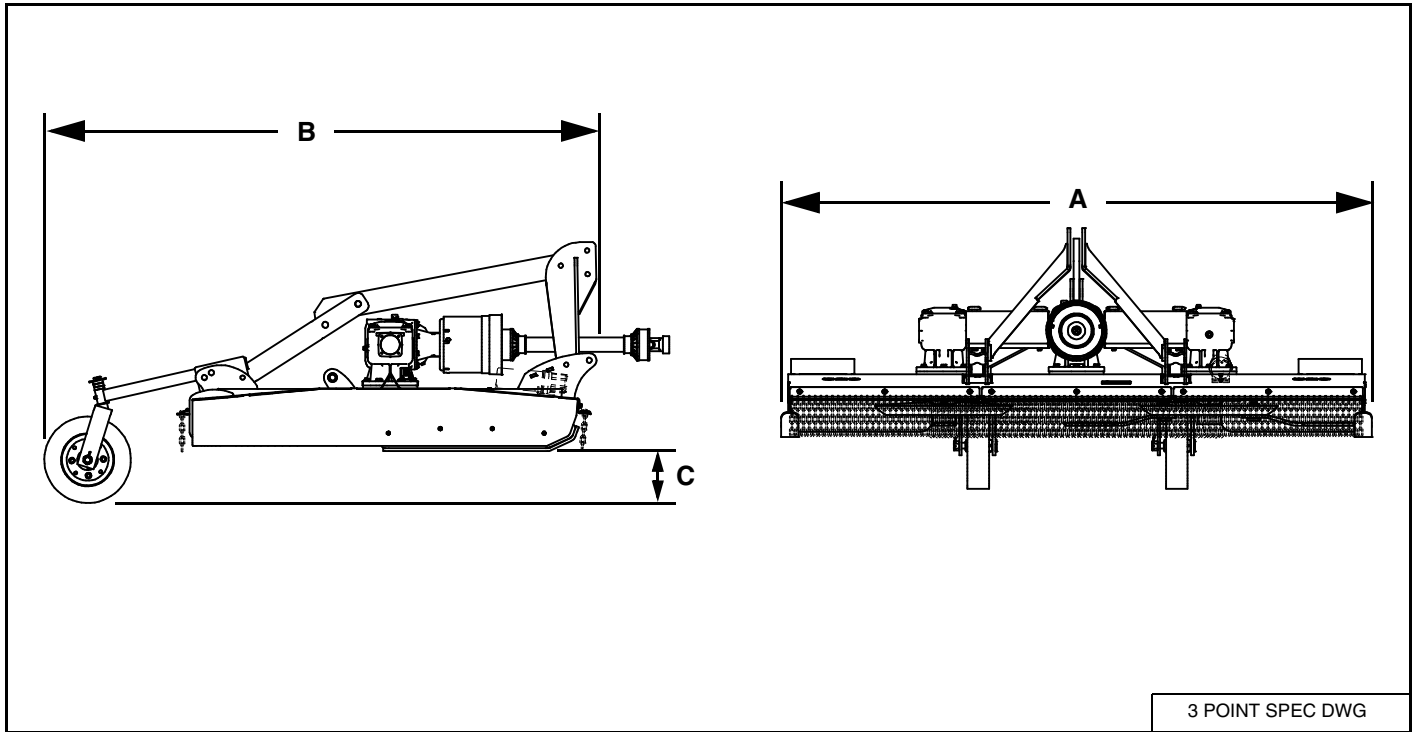

DESCRIPTION	820
Overall Width (A)	102.5 in (3060.7 mm)
Overall Length (B)	95.75 in (2432. mm)
Transport Deck Height (C)	9 in (228.6 mm)

Performance

DESCRIPTION	820
Cutting Height	2 - 11 in. (51 - 279 mm)
Weight	1550 lb (704 kg)
Tractor HP Requirement (Minimum)	40 hp
Blade Tip Speed	16,126 ft/min (8192 m/sec)
Blade Overlap	4 in (177 mm)
Blade	0.5 x 4, Reversible
Stump Jumper	Symmetric die pressed (7 Ga.)
Side Skid	Replaceable
Hitch	Cat I / II 3-Point
Tires	15 in. Solid Rubber Caster Wheels

Pull Type Model Dimensions

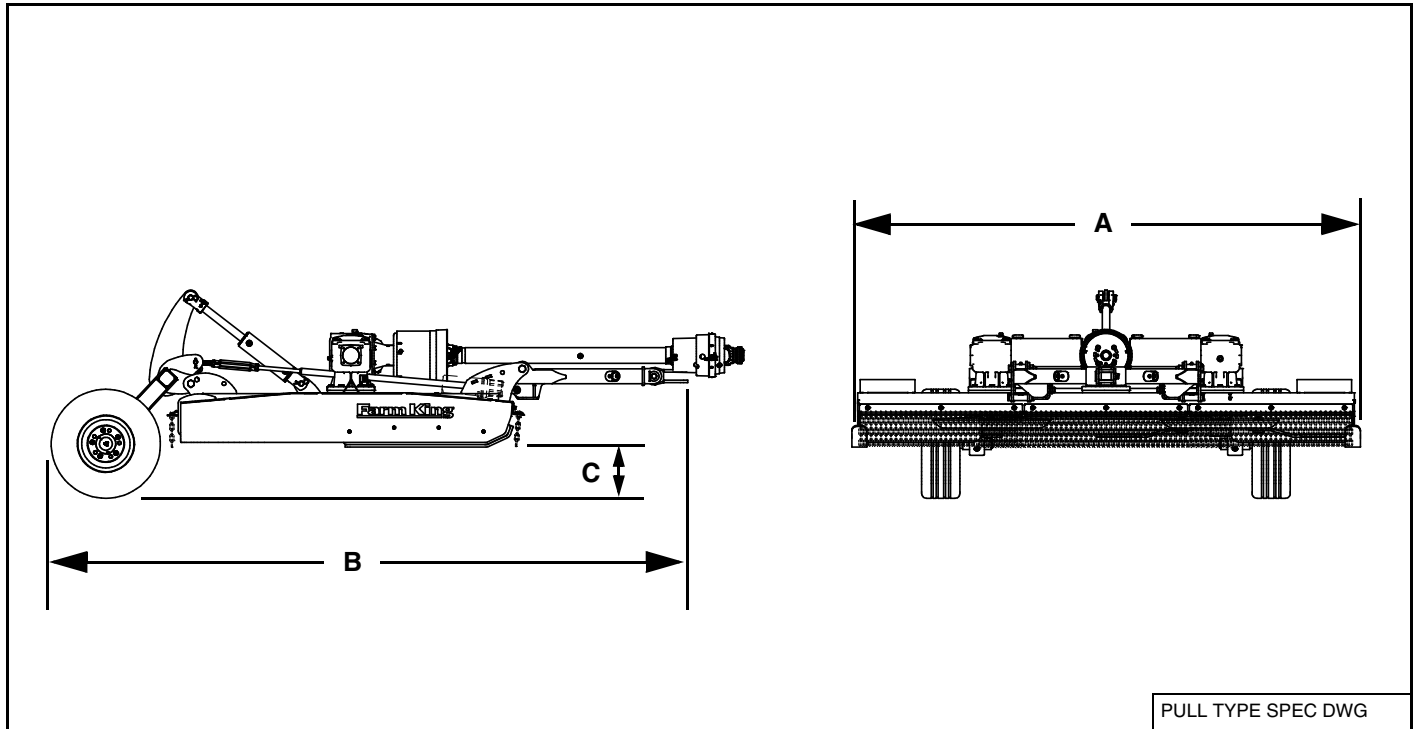

DESCRIPTION	820
Overall Width (A)	102.5 in (3060.7 mm)
Overall Length (B)	128.25 in (3258 mm)
Transport Deck Height (C)	10 in (254 mm)

Performance

DESCRIPTION	820
Cutting Height	2 - 12 in. (51 - 305 mm)
Weight	1640 lb (745 kg)
Tongue Weight	735 lb (334 kg)
Tractor HP Requirement (Minimum)	40 hp
Blade Tip Speed	16,126 ft/min (8192 m/sec)
Blade Overlap	4 in (177 mm)
Blade	0.5 x 4, Reversible
Stump Jumper	Symmetric die pressed (7 Ga.)
Side Skid	Replaceable
Hitch	Swivel Clevis
Tires	24 x 7.7 x 10 Aircraft Tires (Air Filled)
	21 in Laminated Wheels (Solid Rubber)

HARDWARE TORQUE VALUES

Metric Chart

NOTE: Do not use the values listed in the charts if a different torque value or tightening procedure is specified in this manual for a specific application. Torque values listed are for general use only.

Use the following charts to determine the correct torque when checking, adjusting or replacing hardware. **Torque values are listed in newton-meters (inch* or foot pounds) for normal assembly applications.**

Nominal Size	Class 5.8		Class 8.8		Class 10.9		Lock nuts
	Unplated	Plated W / ZnCr	Unplated	Plated W / ZnCr	Unplated	Plated W / ZnCr	CL.8 w/ CL. 8.8 Bolt
M4	1.7 (15*)	2.2 (19*)	2.6 (23*)	3.4 (30*)	3.7 (33*)	4.8 (42*)	1.8 (16*)
M6	5.8 (51*)	7.6 (67*)	8.9 (79*)	12 (102*)	13 (115*)	17 (150*)	6.3 (56*)
M8	14 (124*)	18 (159*)	22 (195*)	28 (248*)	31 (274*)	40 (354*)	15 (133*)
M10	28 (21)	36 (27)	43 (32)	56 (41)	61 (45)	79 (58)	30 (22)
M12	49 (36)	63 (46)	75 (55)	97 (72)	107 (79)	138 (102)	53 (39)
M16	121 (89)	158 (117)	186 (137)	240 (177)	266 (196)	344 (254)	131 (97)
M20	237 (175)	307 (226)	375 (277)	485 (358)	519 (383)	671 (495)	265 (195)
M24	411 (303)	531 (392)	648 (478)	839 (619)	897 (662)	1160 (855)	458 (338)

NOTE: Torque values shown with * are inch pounds.

Identification of Hex Cap Screws and Carriage Bolts - Classes 5 and up

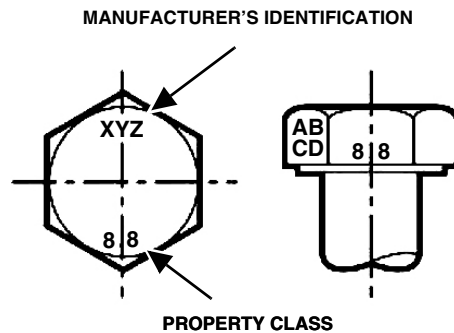

Identification of Hex Nuts and Lock Nuts - Classes 5 and up

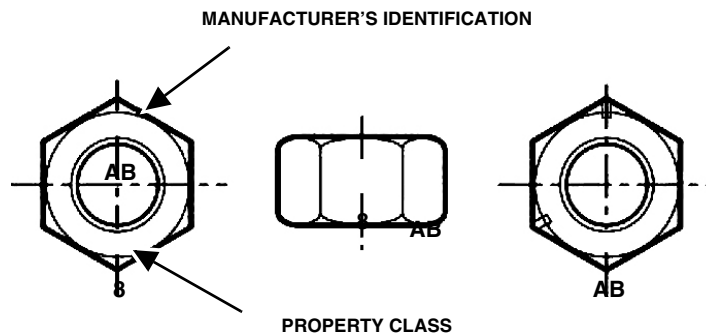

HARDWARE TORQUE VALUES (CONT'D)

Imperial Chart

NOTE: Do not use the values listed in the charts if a different torque value or tightening procedure is specified in this manual for a specific application. Torque values listed are for general use only.

Use the following charts to determine the correct torque when checking, adjusting or replacing hardware. **Torque values are listed in newton-meters (inch* or foot pounds) for normal assembly applications.**

Nominal Size	SAE Grade 5		SAE Grade 8		LOCK NUTS			
	Unplated or Plated Silver	Plated W / ZnCr Gold	Unplated or Plated Silver	Plated W / ZnCr Gold	Unplated or Plated Silver	Plated W / ZnCr Gold	Grade W / Gr. 5 Bolt	Grade W / Gr. 8 Bolt
1/4	6.2 (55*)	8.1 (72*)	9.7 (86*)	12.6 (112*)	13.6 (121*)	17.7 (157*)	6.9 (61*)	9.8 (86*)
5/16	13 (115*)	17 (149*)	20 (178*)	26 (229*)	28 (250*)	37 (324*)	14 (125*)	20 (176*)
3/8	23 (17)	30 (22)	35 (26)	46 (34)	50 (37)	65 (48)	26 (19)	35 (26)
7/16	37 (27)	47 (35)	57 (42)	73 (54)	80 (59)	104 (77)	41 (30)	57 (42)
1/2	57 (42)	73 (54)	87 (64)	113 (83)	123 (91)	159 (117)	61 (45)	88 (64)
9/16	81 (60)	104 (77)	125 (92)	163 (120)	176 (130)	229 (169)	88 (65)	125 (92)
5/8	112 (83)	145 (107)	174 (128)	224 (165)	244 (180)	316 (233)	122 (90)	172 (127)
3/4	198 (146)	256 (189)	306 (226)	397 (293)	432 (319)	560 (413)	217 (160)	306 (226)
7/8	193 (142)	248 (183)	495 (365)	641 (473)	698 (515)	904 (667)	350 (258)	494 (364)
1	289 (213)	373 (275)	742 (547)	960 (708)	1048 (773)	1356 (1000)	523 (386)	739 (545)

NOTE: Torque values shown with * are inch pounds.

Identification of Hex Cap Screws and Carriage Bolts

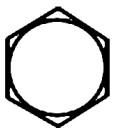

SAE GRADE 2 BOLTS

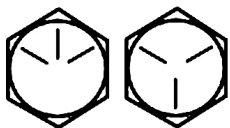

SAE GRADE 5 BOLTS



SAE GRADE 8 BOLTS



SAE GRADE 2 NUTS



SAE GRADE 5 NUTS



SAE GRADE 8 NUTS

Identification of Hex Nuts and Lock Nuts

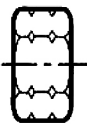

Grade A - No Notches

Grade B - One Circumferential Notch

Grade C - Two Circumferential Notches

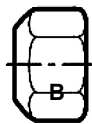

Grade A - No Mark

Grade B - Letter B

Grade C - Letter C

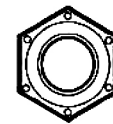

Grade A - No Marks

Grade B - Three Marks

Grade C - Six Marks

(Marks not always located at corners)

HYDRAULIC CONNECTION SPECIFICATIONS

O-Ring Fitting (Straight Thread)

Lubricate the O-ring before installing the fitting. Loosen the jam nut and install the fitting. Tighten the jam nut until the washer is tight against the surface.

O-ring Face Seal Connection

Figure 47

O-ring Face Seal Tightening Torque		
Tubeline O.D.	Thread Size	N•m (ft-lb)
1/4"	9/16" - 18	13 (18)
3/8"	11/16" - 16	22 (30)
1/2"	13/16" - 16	40 (54)
5/8"	1" - 14	60 (81)
3/4"	1-3/16" - 12	84 (114)
7/8"	1-3/16" - 12	98 (133)
1"	1-7/16" - 12	118 (160)
1-1/4"	1-11/16" - 12	154 (209)
1-1/2"	2" - 12	163 (221)

When the fitting is tightened, you can feel when the fitting is tight to eliminate leakage caused by under or over torqued fittings. Use petroleum jelly to hold the O-ring in position until the fittings are assembled.

Flare Fitting

Figure 48

Flare Fitting Tightening Torque		
Tubeline O.D.	Thread Size	N•m (ft-lb)
1/4"	7/16" - 20	13 (18)
5/16"	1/2" - 20	17 (23)
3/8"	9/16" - 18	22 (30)
1/2"	3/4" - 16	40 (54)
5/8"	7/8" - 14	60 (81)
3/4"	1-1/16" - 12	84 (114)
7/8"	1-3/16" - 12	98 (133)
1"	1-5/16" - 12	118 (160)
1-1/4"	1-5/8" - 12	154 (209)
1-1/2"	1-7/8" - 12	163 (221)
2"	2-1/2" - 12	252 (342)

Tighten until the nut makes contact with the seat. Use the chart [Figure 50] to find the correct tightness needed.

NOTE: If the fitting leaks, disconnect and inspect the seat area for damage.

Port Seal (O-ring Boss) Fitting

Figure 49

Port Seal And O-ring Boss Tightening Torque		
Tubeline O.D.	Thread Size	N•m (ft-lb)
1/4"	7/16" - 20	13 (18)
3/8"	9/16" - 18	22 (30)
1/2"	3/4" - 16	40 (54)
5/8"	7/8" - 14	60 (81)
3/4"	1-1/16" - 12	84 (114)
7/8"	1-3/16" - 12	98 (133)
1"	1-5/16" - 12	118 (160)
1-1/8"	1-7/16" - 12	154 (209)
1-1/4"	1-5/8" - 12	163 (221)

NOTE: Port seal and nut, washer and O-ring (O-ring Boss) fittings use the same tightening torque valve chart.

If a torque wrench cannot be used, use the following method.

Tighten the nut until it just makes metal to metal contact, you can feel the resistance.

Tighten the nut with a wrench no more than one hex flat maximum.

Do not over tighten the port seal fitting.

NOTE: If a torque wrench cannot be used, use the hex flat tightening method as an approximate guideline.

NOTE: Port seal fittings are not recommended in all applications. Use O-ring boss fittings in these applications.

Tubelines And Hoses

Replace any tubelines that are bent or flattened. They will restrict flow, which will slow hydraulic action and cause heat.

Replace hoses which show signs of wear, damage or weather cracked rubber.

Always use two wrenches when loosening and tightening hose or tubeline fittings.

Farm King



WARRANTY

WARRANTY101

Farm King



WARRANTY

Farm King

Limited Warranty

BASE LIMITED WARRANTY

Farm King provides this warranty only to original retail purchasers of its products. Farm King warrants to such purchasers that all Farm King manufactured parts and components used and serviced as provided for in the Operator's Manual shall be free from defects in materials and workmanship for a period following delivery to the original retail purchaser of one (1) year. This limited warranty applies only to those parts and components manufactured by Farm King. Parts and components manufactured by others are subject to their manufacturer's warranties, if any.

Farm King will fulfill this limited warranty by, at its option, repairing or replacing any covered part that is defective or is the result of improper workmanship, provided that the part is returned to Farm King within thirty (30) days of the date that such defect or improper workmanship is, or should have been, discovered. Parts must be returned through the selling representative and the buyer must prepay transportation charges.

Farm King will not be responsible for repairs or replacements that are necessitated, in whole or part, by the use of parts not manufactured by or obtained from Farm King. Under no circumstances are component parts warranted against normal wear and tear. There is no warranty on product pump seals, product pump bearings, rubber product hoses, pressure gauges, or other components that require replacement as part of normal maintenance.

REPAIR PARTS LIMITED WARRANTY

Farm King warrants genuine Farm King replacement parts purchased after the expiration of the Farm King Limited Warranty, and used and serviced as provided for in the Operator's Manual, to be free from defects in materials or workmanship for a period of thirty (30) days from the invoice date for the parts. Farm King will fulfill this limited warranty by, at its option, repairing or replacing any covered part that is defective or is the result of improper workmanship, provided that the part is returned to Farm King within thirty (30) days of the date that such defect or improper workmanship is, or should have been, discovered. Such parts must be shipped to the Farm King factory at the purchaser's expense.

WHAT IS NOT COVERED

Under no circumstances does this limited warranty cover any components or parts that have been subject to the following: negligence; alteration or modification not approved by Farm King; misuse; improper storage; lack of reasonable and proper maintenance, service, or repair; normal wear; damage from failure to follow operating instructions; accident; and/or repairs that have been made with parts other than those manufactured, supplied, and / or authorized by Farm King.

AUTHORIZED DEALER AND LABOR COSTS

Repairs eligible for labor under this limited warranty must be made by Farm King or an authorized Farm King dealer. Farm King retains the exclusive discretion to determine whether it will pay labor costs for warranty repairs or replacements, and the amount of such costs that it will pay and the time in which the repairs will be made. If Farm King determines that it will pay labor costs for warranty work, it will do so by issuing a credit to the dealer's or distributor's account. Farm King will not approve or pay invoices sent for repairs that Farm King has not previously approved. Warranty service does not extend the original term of this limited warranty.

Farm King

Limited Warranty

WARRANTY REQUIREMENTS

To be covered by warranty, each new product must be registered with Farm King within thirty (30) days of delivery to original retail purchaser. If the customer decides to purchase replacement components before the warranty disposition of such components is determined, Farm King will bill the customer for such components and then credit the replacement invoice for those components later determined to be covered by this limited warranty. Any such replacement components that are determined not be covered by this limited warranty will be subject to the terms of the invoice and shall be paid for by the purchaser.

EXCLUSIVE EFFECT OF WARRANTY AND LIMITATION OF LIABILITY

TO THE EXTENT PERMITTED BY LAW, FARM KING DISCLAIMS ANY WARRANTIES, REPRESENTATIONS, OR PROMISES, EXPRESS OR IMPLIED, AS TO THE QUALITY, PERFORMANCE, OR FREEDOM FROM DEFECT OF THE COMPONENTS AND PARTS COVERED BY THIS WARRANTY AND NOT SPECIFICALLY PROVIDED FOR HEREIN.

TO THE EXTENT PERMITTED BY LAW, FARM KING DISCLAIMS ANY IMPLIED WARRANTIES OF MERCHANTABILITY AND FITNESS FOR A PARTICULAR PURPOSE ON ITS PRODUCTS COVERED HEREIN, AND DISCLAIMS ANY RELIANCE BY THE PURCHASER ON FARM KING'S SKILL OR JUDGMENT TO SELECT OR FURNISH GOODS FOR ANY PARTICULAR PURPOSE. THE PURCHASER'S ONLY AND EXCLUSIVE REMEDIES IN CONNECTION WITH THE BREACH OR PERFORMANCE OF ANY WARRANTY ON FARM KING'S PRODUCTS ARE THOSE SET FORTH HEREIN. IN NO EVENT SHALL FARM KING BE LIABLE FOR INCIDENTAL OR CONSEQUENTIAL DAMAGES (INCLUDING, BY WAY OF EXAMPLE ONLY AND NOT LIMITATION, LOSS OF CROPS, LOSS OF PROFITS OR REVENUE, OTHER COMMERCIAL LOSSES, INCONVENIENCE, OR COST OF REPLACEMENT OF RENTAL EQUIPMENT). IN NO EVENT SHALL FARM KING'S CONTRACT OR WARRANTY LIABILITY EXCEED THE PURCHASE PRICE OF THE PRODUCT. (Note that some states do not allow limitations on how long an implied warranty lasts or the exclusion or limitation of incidental or consequential damages, so the above limitations and exclusion may not apply to you.) This warranty gives you specific legal rights and you may also have other rights, which vary from state to state.

Farm King neither assumes nor authorizes any person or entity, including its selling representatives, to assume any other obligations or liability in connections with the sale of covered equipment, or to make any other warranties, representations, or promises, express or implied, as to the quality, performance, or freedom from defect of the components and parts covered herein. No one is authorized to alter, modify, or enlarge this limited warranty, or its exclusions, limitations and reservations.

Corrections of defects and improper workmanship in the manner, and for the applicable time periods, provided for herein shall constitute fulfillment of all responsibilities of Farm King to the purchaser, and Farm King shall not be liable in negligence, contract, or on any other basis with respect to the subject equipment.

This limited warranty is subject to any existing conditions of supply which may directly affect Farm King's ability to obtain materials or manufacturer replacement parts.

Buhler Industries Inc. reserves the right to make improvements in design or changes in specifications to its products at anytime, without incurring any obligation to owners of units previously sold.

ALPHABETICAL INDEX

3-POINT HITCH MOUNTED	29
AXLE	65
BLADE PAN	63
BLADES	62
CLEANING THE ROTARY CUTTER	66
EQUIPMENT DECALS AND SIGNS	25
EQUIPMENT IDENTIFICATION	10
FIRE PREVENTION	18
GENERAL INFORMATION	37
GENERAL INFORMATION	71
HARDWARE TORQUE VALUES	95
HYDRAULIC CONNECTION SPECIFICATIONS	97
LUBRICATION	58
OPERATING THE ROTARY CUTTER	46
OWNER'S INFORMATION	9
PRE OPERATION	45
SAFETY INSTRUCTIONS	15
SAFETY SIGN (DECAL) INSTALLATION ..	66
SAFETY SIGN-OFF FORM	26
SAFETY SIGNS (DECALS)	20
SERVICE SCHEDULE	57
SPECIFICATIONS	93
SPLITTER GEARBOX	61
STORAGE AND RETURN TO SERVICE ..	67
TRAILING MODEL	31
TRANSPORTING	50
TROUBLESHOOTING	55
WARRANTY REGISTRATION FORM	5
WARRANTY	101

Farm King



www.farm-king.com

Farm King

1330 43rd Street North
Fargo, ND, 58102
Toll Free: 887.447.6008
E-mail: info@buhler.com
www.farm-king.com

Equipment shown is subject to change without notice.
©2017 Buhler Trading Inc. Printed in USA TSX:BU1

bühler | *a division of Buhler Industries Inc.*