

Farm King

OPERATOR AND PARTS MANUAL

Tandem Disc

8700 LTF Model - Heavy Duty - 3 Section

TTable of Contents

- Introduction5**
- Safety.....6**
 - Safety Instructions6
 - General Safety.....7
 - Assembly Safety7
 - Maintenance Safety8
 - Hydraulic Safety8
 - Transport Safety9
 - Operation Safety9
 - Tire Safety 10
 - Safety Decals..... 10
 - Storage 10
- Specifications..... 11**
 - Tires 11
 - Hydraulic Cylinders..... 11
- Assembly.....13**
 - Hydraulic System for Disc with Super Narrow and Narrow Wing Frames22
 - Hydraulic System for Disc with Wide Wing Frames.....25
 - Gang Beam Chart.....36
 - Gang Pattern - 10-1/2" Spacing - 86/3237
 - Gang Pattern - 10-1/2" Spacing - 90/3237
 - Gang Pattern - 10-1/2" Spacing - 94/3438
 - Gang Pattern - 10-1/2" Spacing - 98/3638
 - Gang Pattern - 12" Spacing - 78/3439
 - Gang Pattern - 12" Spacing - 82/3439
 - Gang Pattern - 12" Spacing - 86/3440
- Operation41**
 - Adjustments46
- Maintenance50**
- Troubleshooting.....58**
- Parts60**
 - Frame and Gang Beam Assembly60
 - Frame and Gang Beam Parts List61
 - Decals (Frame and Gang Beam)66
 - Decals (Frame and Gang Beam) Parts List.....67
 - Hitch and Leveling Crank Assembly68
 - Hitch and Leveling Crank Parts List69

• Rockshaft and Wheel Assembly - w/ Main Frame Walking Beams.....	70
• Rockshaft and Wheel Parts List - w/ Main Frame Walking Beams.....	71
• Rockshaft and Wheel Assembly (Off Highway Option)	74
• Rockshaft and Wheel Parts List (Off Highway Option)	75
• Hydraulic Assembly - Narrow and Super Narrow Wing	76
• Hydraulic Parts List - Narrow and Super Narrow Wing	77
• Hydraulic Assembly - Wide Wing.....	80
• Hydraulic Parts List - Wide Wing.....	81
• Disc Gang - 9" & 10-1/2"	84
• Disc Gang Parts List - 9" & 10-1/2"	85
• Disc Gang - 10-1/2" & 12"	88
• Disc Gang Parts List - 10-1/2" & 12"	89
• Stone Flex Hanger for T2-215 Bearings.....	92
• Stone Flex Hanger for T2-215 Bearings Parts List.....	93
• Standard Scraper and Scraper Bar.....	94
• Standard Scraper and Scraper Bar Parts List	95
• Heavy Duty Scraper and Scraper Bar Assembly	98
• Heavy Duty Scraper and Scraper Bar Parts List	99
• Warning Light Kit	102
• Warning Light Kit Parts List.....	103
• Rockshaft Cylinder	104
• Rockshaft Cylinder Parts List.....	105
• Wing Lift Cylinder	106
• Wing Lift Cylinder Parts List.....	107
Delivery Checklist	109
Warranty	110

Introduction

Keep this manual handy for frequent reference. All new operators or owners must review the manual before using the equipment and at least annually thereafter. Contact your Farm King Dealer if you need assistance, information, or additional copies of the manual. Visit our website at www.buhlerindustries.com/ for a complete list of dealers in your area.

The directions left, right, front and rear, as mentioned throughout this manual, are as seen facing in the direction of travel of the implement.

Safety

Safety Instructions

Remember, YOU are the key to safety. Good safety practices not only protect you, but also the people around you. Make these practices a working part of your safety program. Be certain that everyone operating this equipment is familiar with the recommended operating and maintenance procedures and follows all the safety precautions. Most accidents can be prevented. Do not risk injury or death by ignoring good safety practices.

The alert symbol is used throughout this manual. It indicates attention is required and identifies hazards. Follow the recommended precautions.



The safety alert symbol means...
ATTENTION! BECOME ALERT! YOUR SAFETY IS INVOLVED!



CAUTION

The caution symbol indicates a potentially hazardous situation that, if not avoided, may result in minor or moderate injury. It may also be used to alert against unsafe practices.



WARNING

The Warning Symbol indicates a potentially hazardous situation that, if not avoided, could result in death or serious injury, and includes hazards that are exposed when guards are removed. It may also be used to alert against unsafe practices.



DANGER

The Danger Symbol indicates an imminently hazardous situation that, if not avoided will result in death or serious injury. This signal word is to be limited to the most extreme situations, typically for machine components that, for functional purposes, cannot be guarded.

General Safety

- Have a first-aid kit available for use and know how to use it. Have a fire extinguisher available, stored in a highly visible location, and know how to use it.
- Wear appropriate protective gear. This list may include but is not limited to:
 - hard hat
 - protective shoes with slip resistant soles
 - protective glasses or goggles
 - heavy gloves
 - wet weather gear
 - hearing protection
 - respirator or filter mask
- Read and understand the Operator's Manual and all safety signs before operating, servicing, adjusting, repairing, or unplugging the equipment.
- Do not attempt any unauthorized modifications to your Farm King product as this could affect function or safety, and could affect the life of the equipment.
- Inspect and clean the working area before operating.
- Keep hands, feet, clothing, and hair away from moving parts.
- Ensure bystanders are clear of the area before operating.
- Never allow anyone to ride on the tractor drawbar, or on the disc. The person(s) riding may fall and be seriously or fatally injured.
- Disc should be operated only by persons responsible and qualified to do so.
- Never allow anyone to climb or play on the tractor or disc. They may fall and be seriously injured.
- Only trained competent person(s) shall operate the unit. An untrained operator is not qualified to operate the machine.
- Do not allow riders.
- Lower machine to the ground, place all tractor controls in neutral, stop engine, turn monitor off, set park brake and remove ignition key, before servicing, adjusting, repairing this implement.

Assembly Safety

- When assembling disc, use aligning punch to line up holes. Keep fingers out of holes. Any sudden movement of heavy components will severely injure or sever your fingers.
- Use adequate manpower or hoist to lift the heavy components into place. Attempting to lift heavy components by yourself could cause serious injury.
- Always ensure main and wing frames adequately supported before assembling the components. Inadequate support may result in the heavy components falling and causing serious injury to you or person(s) nearby.
- Be sure all bolts and hydraulic fittings are tight, and all cotter pins are installed in the slotted nuts and pins.
- Do not raise or lower the main or wing frames until all components are securely tightened. Loose components will cause serious damage to the disc and serious injury or death to you and person(s) nearby if the main or wing frames fell.
- Be sure all wheel bolts are checked for tightness during initial transport or when first discing. Loose wheel bolts may result in the wheel falling off, causing serious damage to the disc and may cause serious injury to the operator or person(s) nearby.

- To fill the wing lift cylinders with hydraulic fluid, remove the pin from the shaft end of each wing lift cylinder and pump fluid into the cylinders. Extend and contract the cylinders until they are completely filled with hydraulic fluid. The wings will free-fall if the cylinders are not completely filled with fluid, resulting in serious damage to machine or serious injury or death to person(s) nearby.
- Hydraulic oil escaping under pressure has sufficient force to cause serious injury. Relieve pressure in all hydraulic components before disconnecting any hydraulic components. Before applying pressure to hydraulic system, be sure all connections are tight and components are not damaged. If injured by escaping hydraulic fluid, see a medical doctor immediately.
- When attaching gang assemblies, wear protective gloves to prevent injury from cutting edges of blades.
- Before applying pressure to the hydraulic system, be sure all connections are tight and the components are not damaged.
- Wings will free fall if wing cylinders is not full of oil causing serious damage to machine or serious injury or death to person(s) nearby.
- If hydraulic cylinder shafts are unpinned and cycled to fill them with oil, they can be seriously damaged if clevis of shaft strikes rockshaft arm or wing cylinder.
- Do not stand under folded wings when working on disc. If hydraulic system failed or if hydraulic lever was accidentally operated, wings may fall resulting in serious injury or death to person(s) near disc.
- When assembling gangs ensure adequate support is placed under main frame and wing frame. Do not use lock out valves as safety device to prevent frame from falling. If any hydraulic component failed, disc could drop causing serious injury or death to person(s) nearby.

Maintenance Safety

- Lower machine to the ground, place all tractor controls in neutral, stop engine, turn monitor off, set park brake and remove ignition key before servicing, adjusting, or repairing this disc.
- Follow good shop practices:
 - Keep service area clean and dry.
 - Be sure electrical outlets and tools are properly grounded.
 - Use adequate light for the job at hand.
- Before applying pressure to a hydraulic system, make sure all components are tight and hoses and couplings are in good condition.
- Relieve pressure from hydraulic cylinder before servicing or disconnecting from tractor.
- Clear the area of bystanders when carrying out any maintenance and repairs or making any adjustments.
- Place stands or blocks under the frame before working beneath the machine or when changing tires.
- Use only tools, jacks and hoists of sufficient capacity for the job.

Hydraulic Safety

- Always place all tractor hydraulic controls in neutral before dismounting.
- Make sure that all components in the hydraulic system are kept in good condition and are clean.
- Replace any worn, cut, abraded, flattened or crimped hoses.
- Do not attempt any makeshift repairs to the hydraulic lines, fittings or hoses by using tape, clamps or cements. The hydraulic system operates under extremely high pressure. Such repairs will fail suddenly and create a hazardous and unsafe condition.

- Wear proper hand and eye protection when searching for a high pressure hydraulic leak. Use a piece of wood or cardboard as a backstop instead of hands to isolate and identify a leak.
- If injured by escaping hydraulic fluid, seek medical attention immediately. Serious infection or toxic reaction can develop from hydraulic fluid penetrating the skin surface.
- Before applying pressure to the system, make sure all components are tight and that hoses and couplings are in good condition.

Transport Safety

- Read and understand all the information in the Operator's Manual regarding procedures and safety before operating this disc in the field and/or on the road.
- Check with local authorities regarding transporting this implement on public roads.
- Always transport at a safe speed. Use caution when turning corners or meeting traffic.
- Make sure the SMV (Slow Moving Vehicle) emblem and all the lights and reflectors that are required by the local highway and transport authorities are in place, are clean and can be seen clearly by all overtaking and oncoming traffic.
- Be sure all amber and red lights are working to safeguard against rear end collisions. Daybreak and dusk are particularly dangerous.
- Be sure that the disc is securely attached to the tractor. Always use a safety chain between the machine and the tractor.
- Do not exceed 20 mph (32 km/h). Reduce speed on rough roads and surfaces.
- Always use hazard warning flashers on tractor and when transporting unless prohibited by law.
- Stay away from overhead high voltage electrical lines when transporting disc. Electrocution can occur without direct contact.

Operation Safety

- Lower machine to the ground, place all tractor controls in neutral, stop engine, set park brake and remove ignition key before servicing, adjusting or repairing implement.
- Do not allow riders on the disc or tractor during operation or transporting.
- Clear the area of all bystanders, before moving tractor and disc.
- Stand clear when folding or unfolding wings. Keep others away.
- Clean reflectors, SMV and lights before transporting.
- Attach disc securely to tractor using a hardened pin and a safety chain.
- Do not exceed a safe travel speed.
- Use hazard flasher on tractor and disc when transporting.
- Stay away from overhead power lines when folding or unfolding wings and during transport.
- Before applying pressure to the hydraulic system, make sure all components are tight and that hoses and couplings are in good condition.
- Review safety instructions annually.

Tire Safety

- Failure to follow proper procedures when mounting a tire on a wheel or rim can produce an explosion which may result in serious injury or death.
- Do not attempt to mount a tire unless you have the proper equipment and experience to do the job.
- Have a qualified tire dealer perform required tire maintenance.

Safety Decals

- Keep all decals clean and in good condition to provide you with a constant reminder of safe operating procedures.
- Replace any destroyed, missing or illegible decals.

Storage

- Store unit in an area away from human activity.
- Do not permit children to play on or around parked implement.

Specifications

Model	Blade Spacing	Approx. Cutting Width	# of Blades	# of Gang Bearings	Gang Bearing Type	Approx. Transport Width	Approx. Transport Height
86	10-1/2"	37'	86	32	T2-215	17'0"	13'6"
90	10-1/2"	38-1/2'	90	32	T2-215	17'0"	13'6"
94	10-1/2"	40-1/2'	94	34	T2-215	17'0"	13'6"
98	10-1/2"	42'	98	36	T2-215	17'0"	13'6"
78	12"	38-1/2'	78	34	T2-215	17'0"	13'6"
82	12"	40-1/2'	82	34	T2-215	17'0"	13'6"
86	12"	42-1/2'	86	34	T2-215	17'0"	13'6"

Tires

Tire Location	Tire Sizes	Pressure
Center Frame	4 - 15.0/55-17 - L/R F	85 PSI (586 KPA)
Wing Frame	4 - 12.5L x 15 FI, L/R D	55 PSI (379 KPA)

Hydraulic Cylinders

Application	Size	Required	Machine Size
Center Frame Lift	4" x 24"	1	All Sizes
L.H. Wing Frame Lift	3-1/2" x 24"	1	All Sizes
R.H. Wing Frame Lift	3" x 24"	1	All Sizes
Wing Lift	5" x 36"	4	All Sizes
Outer Flip Wing	4" x 24"	2	All Sizes

**CAUTION**

When inflating tires use a clip-on chuck and hose extension which will allow operator to stand clear of tire and wheel assembly. Do not stand in front or over tire when inflating. Exploding tire and wheel parts can cause serious injury.

Gang Angle

- Front Gang - Fixed - 21°s (Fixed)
- Rear Gang - Fixed - 19°s (Fixed)

Bolt Torques

- Gang bolts - 1-15/16" (49mm) diameter 3200 ft lbs (4339 N.m)
- Gang beam bolts - 1-1/4" (31.7 mm) diameter 840 ft lbs (1139 N.m)
- Leveling crank bolts - 1-1/4" (31mm) diameter 840 ft (1139 N.m)
- Wheel bolts - 9/16" (14mm) diameter 150 ft lbs (203 N.m)
- Bearing hanger u-bolts - 7/8" (22mm) diameter 430 ft lbs (583.0 N.m) (Solid Hangers)

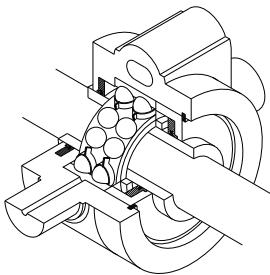
**T2-215 GREASEABLE BEARING**

Assembly Instructions

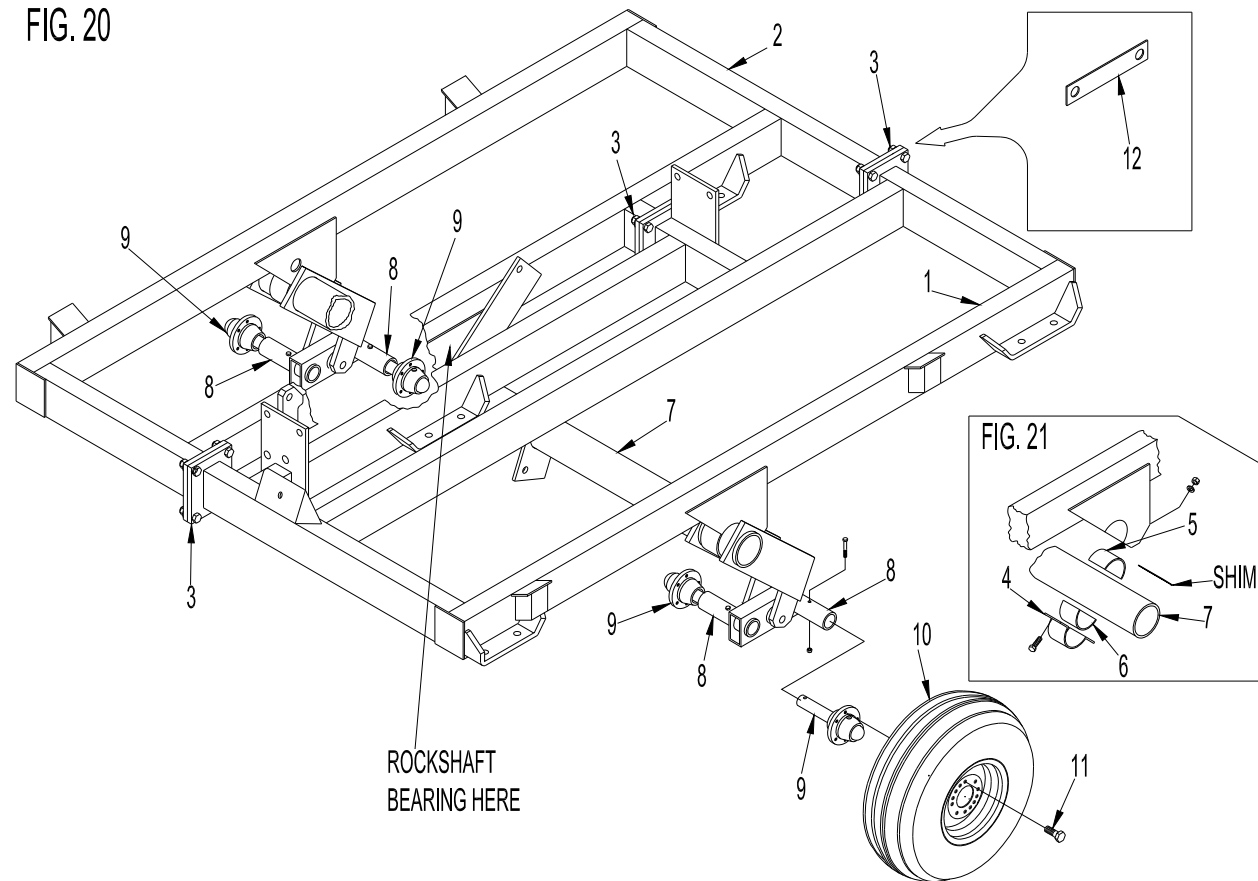

1. See FIG. 20. Fasten L.H. main frame, arrow 1, and R.H. main frame half, arrow 2, together as shown. Main frame halves are fastened with four (4) 1" x 3-1/4" (25.4 mm x 82.6 mm) hex bolts c/w nuts and lockwashers at the front, rear and inner connecting plates, arrow 3. Do not tighten bolts at this time. Bolt should be drawn to point where the lockwasher starts to collapse. Connecting plates should be fully in contact with each other.
2. See FIG. 20. Raise frame assembly, arrow 1 and 2, approximately 46" (1168 mm) from ground and block securely.
3. See FIG. 21. Locate six (6) plastic bearing liners, arrow 5 and 6, the one of the shipping cartons. Choose three (3) with 45° grease fittings and three (3) with straight grease fittings. Place a layer of grease on inside surface of each liner.

- See FIG. 20 and 21. Remove cap, arrow 4, from each of the three rockshaft bearings. Next place one bearing liner, arrow 5, in each bearing using liner with 45° grease fitting. Install rockshaft, arrow 7, into the three bearings on main frame assembly. Position rockshaft so that outside bearings are positioned between wheel legs. Place bearing liner, arrow 6, over rockshaft using liner with straight grease fitting. Then secure rockshaft to each bearing with one bearing cap, arrow 4. Install necessary shims between bearing cap and bearing. Tighten bolts.

NOTE: It will be necessary to install shims between half-clamp, arrow 4, and rockshaft bearing, to allow rockshaft to turn freely in bearing after bolts have been tightened. It is important to install correct number of shims. Normally 2 shims on top and 3 shims on bottom will provide correct clearance. Too many shims will leave a gap between bearing liners and rockshaft, not enough shims will cause bearing to be too tight resulting in premature liner wear. Rockshaft must be snug but free to turn.

- See FIG. 20. The rockshaft is now holding the frame level. Now check if each set of connection plates, arrow 3, are making full contact with each other. If there is a gap between the plates at the top or bottom, place 2" x 8" (50.8mm x 203mm) shim plate, arrow 12, between connector plates. After required shims are installed, tighten all 1" x 3-1/4" (25.4mm x 82.6mm) bolts.

**WARNING**

Support main frame securely before assembling components. Inadequate may result in the heavy components falling and causing serious injury to you or person(s) nearby.

- Installing hub assemblies

G - Walking Beam Type. See FIG. 20. Install four (4) eight bolt hub and spindle assemblies, arrow 9, into walking beam tubes, arrow 8. Fasten each spindle to the tube with one (1) 1/2" x 4" (12.7 mm x 102 mm) N.C. hex bolts complete with 1/2" (12.7 mm) nylon locknut.

H - Australia only: Non-walking beam type. See FIG.22. Install four (4) eight bolt hub and spindle assemblies, arrow 8, into rockshaft, arrow 7. Fasten each spindle with one (1) 1/2" x 4" (12.7 mm x 102 mm) N.C. hex bolt complete with 1/2" (12.7 mm) nylon locknut.

- Installing tire and wheel assemblies

A - Walking beam type. See FIG. 20. Install one (1) eight bolt tire and wheel assembly, arrow 10, to hub assembly, arrow 9, on each side of each wheel leg. Centre frame uses 15.0/55-17 load range I tires. Secure back wheel with eight (8) 9/16" x 1-11/16" (14.2 mm x 42.7 mm) wheel bolts, arrow 11. Tighten wheel bolts to 150 ft. lbs. (203 N.m). Lock each wheel bolt by installing one (1) 9/16" (14.2 mm) N.F. hex nut on thread that extends past hub. Tighten nuts.

B - Optional: Non-walking beam type. See FIG.22. Install one (1) eight bolt tire and wheel assembly, arrow 9, on each side of each wheel lug. Centre frame uses 40 x 19 x 19.5 off highway tires. Secure with eight (8) 9/16" x 1-11/16" (14.2 mm x 42.7 mm) wheel bolts, arrow 10. Tighten wheel bolts to 150 ft lbs. (203 N.m). Lock each wheel bolt by installing one (1) 9/16" (14.2 mm) N.F. hex nut on thread that extends past hub. Tighten nuts.

**WARNING**

Wheel bolts must be kept tight. If bolts are not tight they will loosen causing severe damage to hub, wheel and tire. Check wheel bolts periodically, especially the first few hours of operation, either transport or field work.

**WARNING**

Use adequate manpower or a hoist to lift heavy components in place. Attempting to lift heavy components by yourself could cause serious injury.

**CAUTION**

When assembling disc use aligning punches to line up holes. Keep fingers out of holes.

FIG. 22 (OPTIONAL)

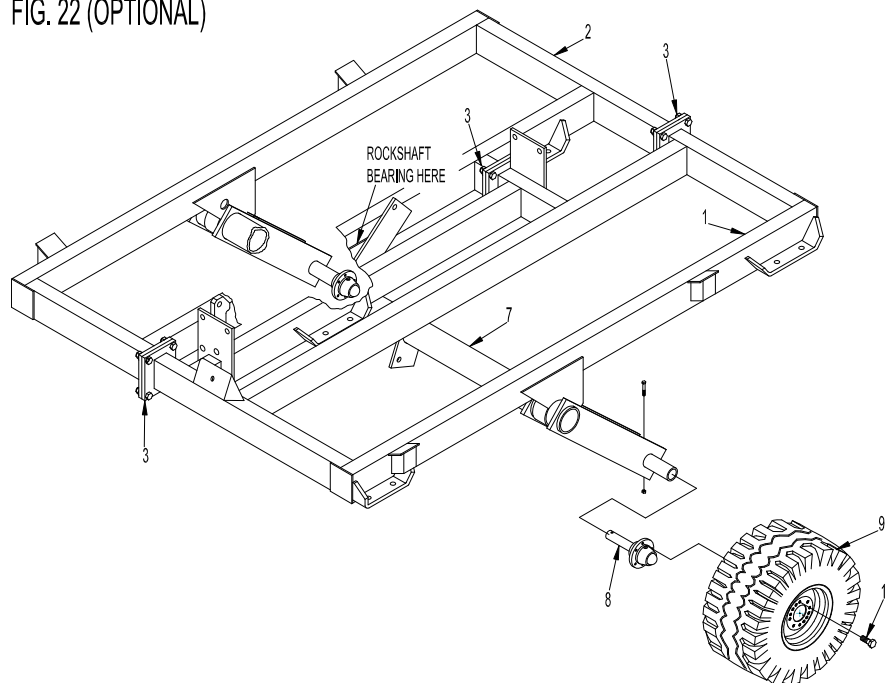
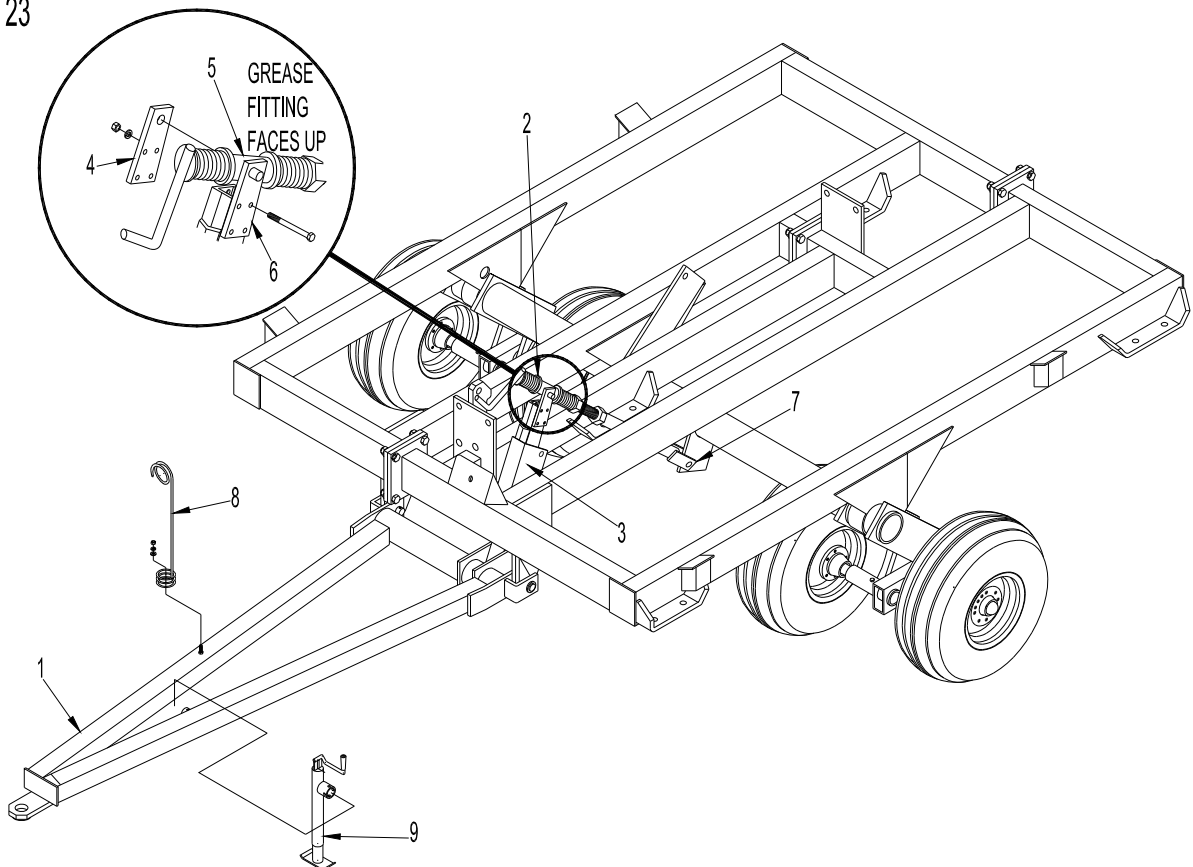

FIG. 23



8. See FIG. 23. Attach hitch assembly, arrow 1, to hitch lugs on main frame with two (2) 1-1/2" dia. x 5" (38.1 mm dia. x 127 mm) pins. Secure each pin with one (1) 7/16" (10.9 mm) lynch pin.
9. See FIG. 23. To attach leveling crank, arrow 2, to leveling arm, arrow 3, remove bolt-on lug, arrow 4, of hitch leveling arm. Next, install 1" (25 mm) diameter pin of bearing tube, arrow 5, into weld-on lug, arrow 6, of levelling arm. Position bearing tube so grease fitting is facing up. Place bolt-on lug, arrow 4, over outside of leveling crank. Install 1" (25 mm) diameter pin of bearing tube into bolt-on lug. Fasten the bolt-on lug to the leveling arm with four (4) 1/2" x 5" (12.7 mm x 127 mm) N.C. hex bolts c/w nuts and lockwashers.
10. See FIG. 23. Attach clevis end of levelling link, arrow 2, to arm, arrow 7, on rockshaft. Fasten with one 1-1/4" x 4-3/4" (31.7 mm x 120.6 mm) bolt c/w nut and lockwasher. Tighten bolt to 840 ft. lbs. (1139 N.m).

NOTE: The 1-1/4" x 4-3/4" (31.7 mm x 120.6 mm) bolt must be tightened so that the clevis is drawn up tight against the ball joint in arm, arrow 7. Tighten bolt to 840 ft lbs (1139 N.m). Ball must also be free to pivot in socket. Lubricate ball with oil and turn in socket to make sure ball is free to pivot.

11. See FIG. 23. Fasten hose support, arrow 8, to a bolt welded to top of hitch. Secure with (1) 5/8" (15.7 mm) nut, (1) 11/16" (17.2 mm) I.D. flatwasher, and (1) 5/8" (15.7 mm) lockwasher.

12. See FIG. 23. Mount hitch jack, arrow 9, on round tube welded to inside of hitch. Jack pivots on mounting tube and can be placed in vertical position for supporting disc hitch or horizontal position while disc is in motion. Lock jack in desired position with pin.

NOTE: Jack must be in horizontal position when disc is in motion. If jack is in vertical position when disc is in motion, jack may strike ground or obstruction on ground, causing severe damage to jack, be sure crank of jack is not hanging below hitch when jack is in horizontal position. Place crank on top of hitch to avoid damage.

FIG. 24

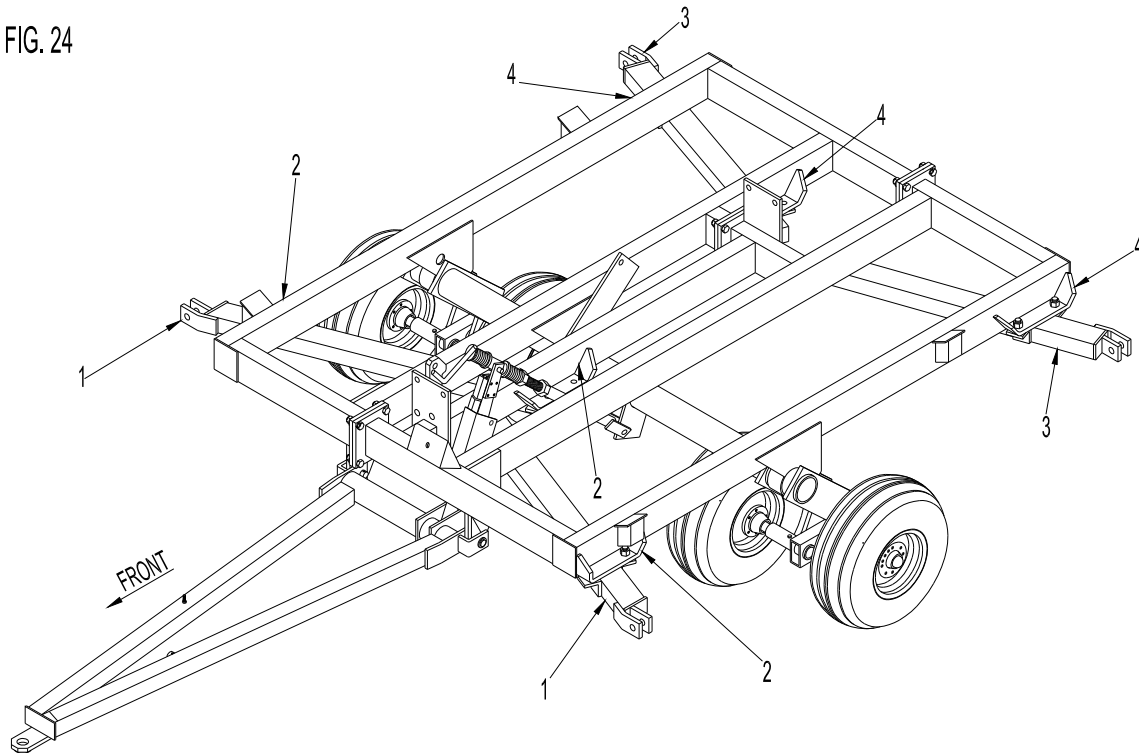

13. Attaching main frame gang beams - See FIG. 24 and 25

NOTE: Determine front and rear main frame gang beams by appearance and length. Main frame gang beams have clevis ends as shown in FIG. 24. The front gang beams are longer than the rear gang beams. For gang beam lengths refer to chart.

A - Attach front gang beams, arrow 1, to mount brackets, arrow 2, welded to inside and outside frame members. Fasten each gang beam with two (2) 1-1/4" x 3-1/2" (31.7 mm x 88.9 mm) N.C. hex bolts c/w nuts and lockwashers at each mount bracket. Front gang beams are L.H. and R.H. and must be positioned as shown. Tighten bolts to 840 ft lbs (1139 N.m).

B - Attach rear gang beams, arrow 3, to mount brackets, arrow 4, welded to inside and outside frame members. Fasten each gang beam with two (2) 1-1/4" x 3-1/2" (31.7 mm x 88.9 mm) N.C. hex bolts c/w nuts and lockwashers at each mount bracket. Rear gang beams are L.H. and R.H. and must be positioned as shown. Tighten bolts to 840 ft lbs (1139 N.m).

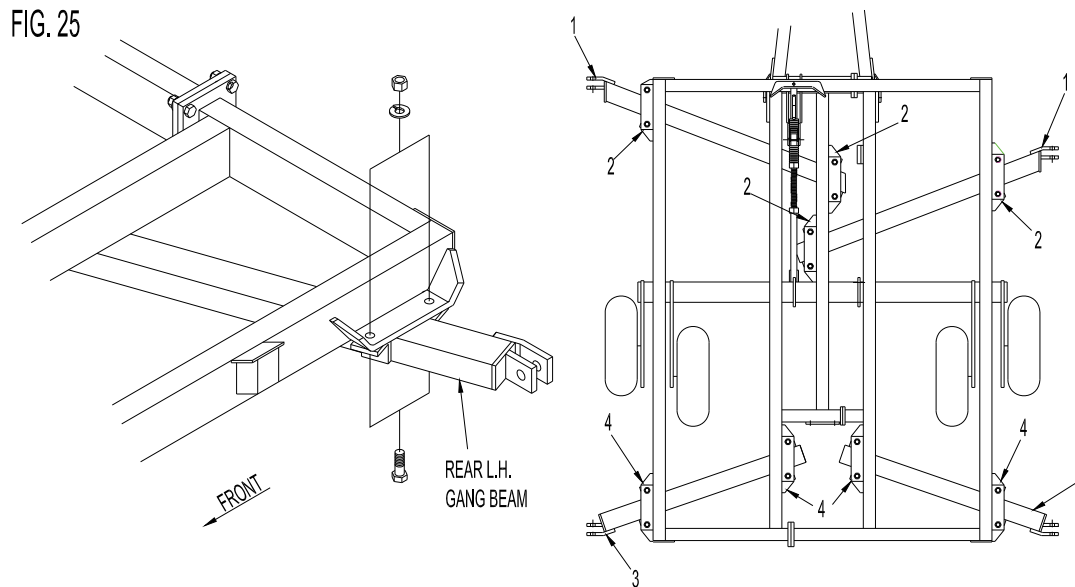

14. See FIG. 26. Raise inner wing frame assemblies, arrow 3 and 4, approximately 36" (914 mm) from ground and block securely. Locate one (1) wing frame on each side of main frame. Wing frames are L.H. and R.H. and must be positioned as shown.

15. Attaching Inner Wing Frame Gang Beams - See FIG. 26

NOTE: Determine front and rear gang beams by appearance and length. Inner wing frame gang beams have tongue type ends as shown in FIG. 26. The front gang beams are shorter than the rear gang beams. For gang beam lengths refer to chart.

A - Attach front gang beams, arrow 1, to mount brackets, arrow 2, welded to inside and outside frame members. Fasten each gang beam with two (2) 1-1/4" x 3-1/2" (31.7 mm x 88.9 mm) N.C. hex bolts c/w nuts and lockwashers at each mount bracket. Front gang beams are L.H. and R.H. and must be positioned as shown. Do not tighten bolts.

B - Attach rear gang beams, arrow 5, to mount brackets, arrow 6, welded to inside and outside frame members. Fasten each gang beam with two (2) 1-1/4" x 3-1/2" (31.7 mm x 88.9 mm) N.C. hex bolts c/w nuts and lockwashers at each mount bracket. Rear gang beams are L.H. and R.H. and must be positioned as shown. Do not tighten bolts.

16. See FIG. 26 - Attach each wing frame assembly to main frame by connecting gang beams. Insert tongue of wing beams into clevis of main frame beams. Bolt each hinge assembly together with one (1) 1-1/2" x 5" (38.1 mm x 127 mm) threaded pin, arrow 7, and slotted nut, arrow 8. Secure slotted nut with one (1) 5/16" x 2" (7.8 mm x 50.8 mm) cotter pin, arrow 9.



WARNING

Use adequate manpower or a hoist to lift heavy components into place. Attempting to lift heavy components by yourself could cause serious injury.

**WARNING**

Support wing frames securely before assembling components. Heavy frames could cause serious injury if it fell.

**CAUTION**

When assembling disc, use aligning punch to line up holes. Keep fingers out of holes.

17. See FIG. 26. Fasten L.H. and R.H. wing rockshafts, arrow 10 and 11, to bottom of L.H. and R.H. wing frames. Be sure correct rockshaft is used. Wheel leg points forward with cylinder arm on top. Secure each rockshaft to two (2) bearing brackets, arrow 16, with two (2) sets of 5-1/2" (139.7 mm) rockshaft bearings, arrow 17. Fasten each rockshaft bearing set to bearing bracket with two (2) 3/4" x 6-1/2" (19 mm x 165 mm) hex bolts c/w nuts and lockwasher. Position top half of rockshaft bearing so grease hole faces front. Position bottom half of rockshaft bearing so grease holes faces the rear. After tightening rockshaft bearing bolts, rockshaft should be free to pivot in bearing.

NOTE: If rockshaft bearing are too tight and don't allow rockshaft to turn freely, place necessary 2" x 3" (50.8 x 76.2) shims, arrow 12, (as required) between bearing halves. Shim(s) are packed in hydraulic hose and fitting box.

NOTE: Before installing rockshaft bearings place a coat of grease on bearing surface.

18. See FIG. 27. Install one (1) grease fitting, arrow 13, in top half of each bearing assembly.
19. See FIG. 26. Install two (2) 6 bolt hub and spindle assemblies, arrow 15, into spindle mounting tubes at bottom of wheel leg of each rockshaft, arrows 10 and 11. Secure each spindle with one (1) 1/2" x 3-1/2" (12.5mm x 89mm) hex bolt c/w nylon lock nut.
20. See FIG. 26. Install one (1) six bolt tire and wheel assembly, arrow 14, to each hub assembly, arrow 15. Secure each wheel with six (6) 9/16" x 1-1/8" (14.2mm x 28.5mm) wheel bolts tighten wheel bolts to 15 ft lbs (203 N.m).
21. See FIG. 26. Raise outer wing frame assemblies, arrow 18 and 19, approximately 36" (914 mm) from ground and block securely. Locate one (1) wing frame on each side of main frame. Wing frames are L.H. and R.H. and must be positioned as shown. Connect each outer wing frame to inner wing frame by placing hinge lugs, arrow 24, of outer wings over hinge lug, arrow 25, of inner wing frame. Bolt each hinge assembly together with one (1) 1-1/2" x 5" (38 x 127mm) threaded pin, arrow 26, and slotted nut, arrow 27. Secure slotted nut with one (1) 5/8" x 2" (16 x 50.8mm) cotter pin, arrow 28.
22. Attaching outer wing frame gang beams - See FIG. 26.

NOTE: Determine front and rear gang beams by appearance and length. Outer wing frame gang beams do not have hinge lugs welded at one end. The front gang beams are shorter than the rear gang beams. For gang beam lengths refer to chart

A - Attach front gang beams, arrow 20, to mount brackets, arrow 21, welded to inside and outside frame members. Fasten each gang beam with two (2) 1-1/4" x 3-1/2" (31.7 mm x 88.9 mm) N.C. hex bolts c/w nuts and lockwashers at each mount bracket. Front gang beams are L.H. and R.H. and must be positioned as shown. Do not tighten bolts.

B - Attach rear gang beams, arrow 22, to mount brackets, arrow 23, welded to inside and outside frame members. Fasten each gang beam with two (2) 1-1/4" x 3-1/2" (31.7 mm x 88.9 mm) N.C. hex bolts c/w nuts and lockwashers at each mount bracket. Rear gang beams are L.H. and R.H. and must be positioned as shown. Do not tighten bolts.

23. Attaching outer wing folding mechanism - See FIG. 27

A - See FIG. 27. Fasten L.H. and R.H. Diamond brackets, arrow 1, to the inner wing hinge beam, arrow 4, with (1) 1-1/4" x 9" (31.7 x 287mm) N.C. hex bolt, arrow 2, c/w 1-1/4" (288.6mm) N.C. locknut, arrow 3.

B - See FIG. 27. Fasten one end of each link strap, arrow 5 and 6, to diamond bracket, arrow 1 with 1" x 8" (25.4 x 203.2mm) N.C. hex bolt, arrow 7, c/w locknut, arrow 8. Fasten other end of each link strap, arrow 5 and 6, to bottom lug, arrow 12, on outer wing. Secure with (1) 1" x 8" (25.4 x 203.2mm) N.C. hex bolt, arrow 7, c/w locknut, arrow 8.

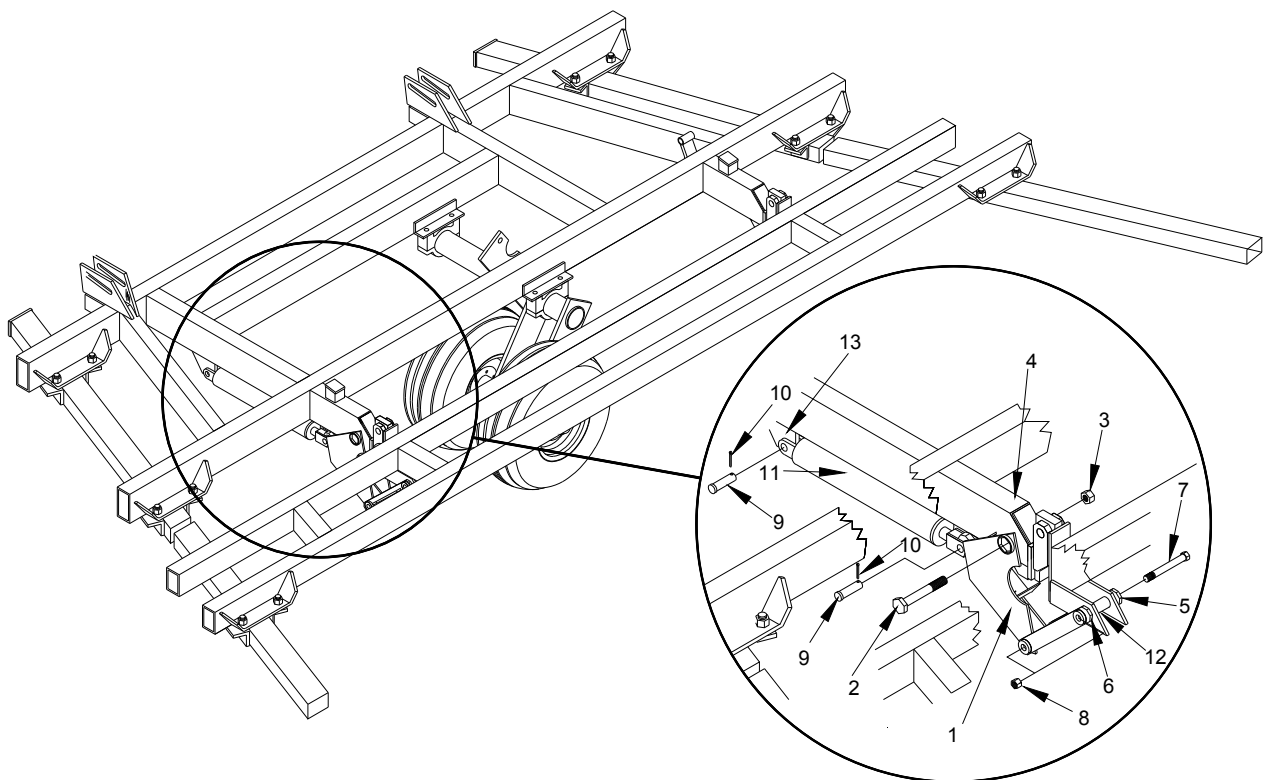

C - See FIG. 27. Fasten barrel end of 4" x 24" (101.6 x 609.6mm) outer wing lift cylinder, arrow 11, to cylinder lug, arrow 13, under inner wing frame. Position cylinder so ports are facing rear of disc. Fasten shaft end of 4" x 24" (101.6 x 609.6mm) outer wing cylinder, arrow 11, to lug on diamond bracket, arrow 1. Secure each end of cylinder with one (1) 1-1/4" x 4-3/16" (31.75 x 120.9mm) pin, arrow 9, c/w 5/16" x 2" (7.9 x 50.8mm) cotter pin arrow 10.

FIG. 28

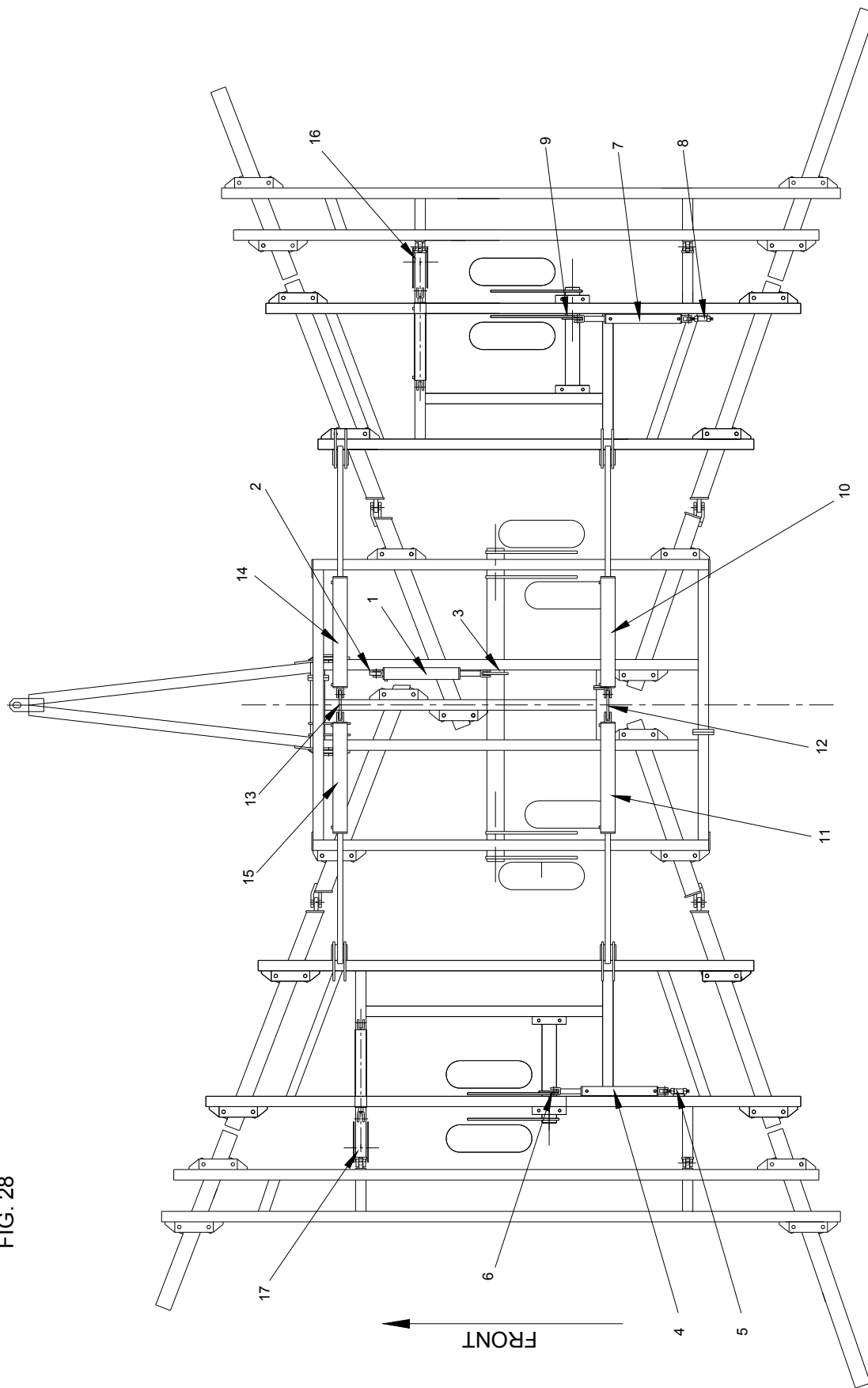

24. See FIG. 28. Fasten one (1) 4" x 24" (101.6 mm x 610 mm) lift cylinder, arrow 1, to main frame and rockshaft arm. Fasten barrel end to cylinder lug, arrow 2. Position so ports face L.H.S. Fasten shaft end to cylinder arm, arrow 3, on rockshaft. Fasten each end of cylinder with one (1) 1-1/4" x 4-3/16" (31.7 mm x 106.4 mm) clevis pin. Secure cylinder pins with one (1) 5/16" x 2" (7.9 mm x 50.8 mm) cotter pin.
25. See FIG. 28. Fasten one (1) 3-1/2" x 24" (88.9 mm x 610 mm) rockshaft cylinder, arrow 4, to L.H. wing frame and rockshaft arm. Fasten barrel end to 1-1/4" x 8" (31.7 mm x 203 mm) I-Bolt, arrow 5. Position so ports face up. Fasten shaft end to cylinder arm, arrow 6, on rockshaft. Fasten each end of cylinder with one(1) 1-1/4" x 4-3/16" (31.7 mm x 106.4 mm) clevis pin. Secure cylinder pins with one (1) 5/16" x 2" (7.9 mm x 50.8 mm) cotter pin.
26. See FIG. 28. Fasten one (1) 3" x 24" (76.2 mm x 610 mm) rockshaft cylinder, arrow 7, to R.H. wing frame and rockshaft arm. Fasten barrel end to 1-1/4" x 8" (31.7 mm x 203 mm) I-Bolt, arrow 8. Position so ports face up. Fasten shaft end to cylinder arm, arrow 9, on rockshaft. Fasten each end of cylinder with one (1) 1-1/4" x 4-3/16" (31.7 mm x 106.4 mm) clevis pin. Secure cylinder pins with one (1) 5/16" x 2" (7.9 mm x 50.8 mm) cotter pin.

NOTE: If cylinder pin on barrel end is not positioned properly, serious damage may occur to cylinder or I-bolt. If cylinder is turned so axis of cylinder pin is not horizontal, cylinder will not be free to pivot up and down when cylinder is activated..

27. Attaching wing lift cylinders - See FIG. 28.

Fasten two (2) 5" x 36" (127 mm x 914 mm) wing lift cylinders, arrow 14 and 15, at front of main frame. Position each cylinder with ports facing towards centre of disc. Fasten barrel end of each cylinder to lug, arrow 13, with one (1) 1-1/4" x 4-3/16" (31.7 mm x 106.4 mm) clevis pin. Secure each pin with one (1) 5/16" x 1-3/4" (7.9 mm x 44.5 mm) cotter pin. Attach shaft end of wing lift cylinder after cylinders have been filled with oil. Do not attach shaft ends at this time.



WARNING

Do not stand under wing while is being raised or lowered. If any component should fail, or if hydraulic lever should accidentally be operated, wing could drop.



CAUTION

Wings will free fall if wing cylinders are not full of oil causing serious damage to machine or serious injury or death to person(s) nearby.



CAUTION

When transporting disc always place hydraulic lock up valves in closed position. If hydraulic lever was accidentally operated, the disc could drop or wings could fall.

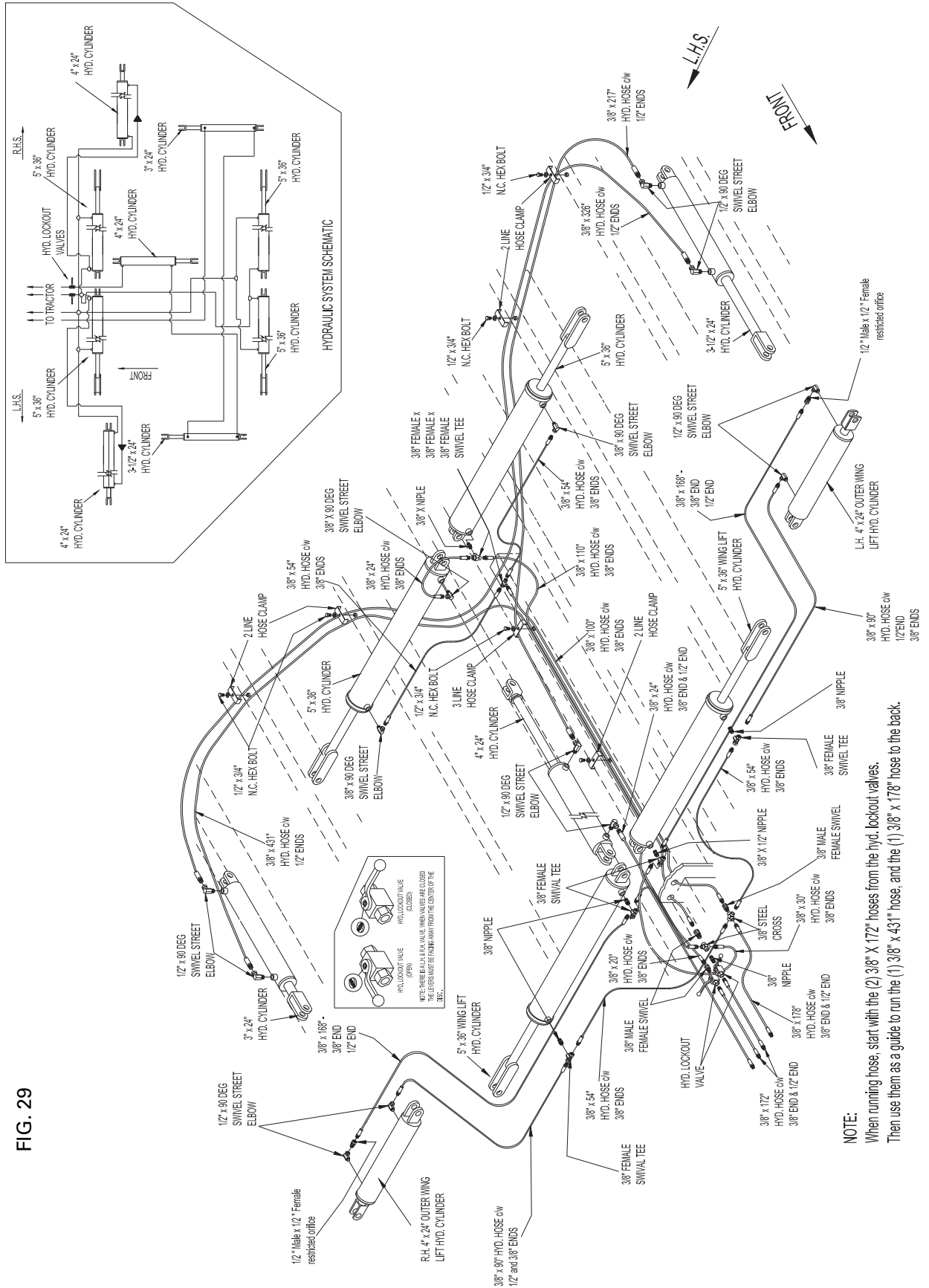

28. See FIG. 30. Place two (2) hydraulic lockup valves, arrow 1 and 2, in bracket, arrow 3, welded to front centre of main frame. Valves are assembled L.H. and R.H. Position valves as shown so Handle moves out when closing valve (as shown) and forward when opening valves. Position valves between front and rear holes in bracket, arrow 3, then installing (2) 1/4" x 4" (6.35 x 101.6mm) N.C. hex bolt c/w nuts and lockwashers in bracket to hold valves in place.

FIG. 30

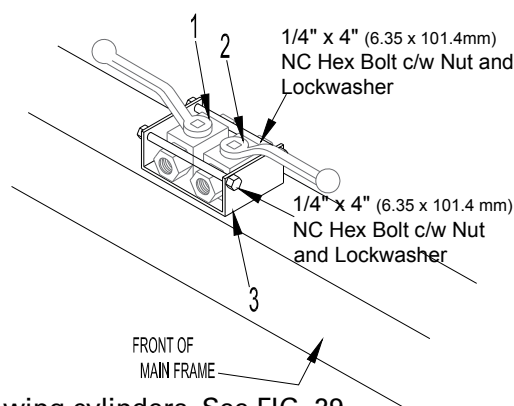

29. Attaching hydraulic hose to rockshaft cylinders and wing cylinders. See FIG. 29.

NOTE: Do not use teflon tape to seal hydraulic hose and fittings. If pieces of tape get into the hydraulic system they may plug orifices.

NOTE: To ensure that the hydraulic system does not leak, seal fittings and hoses with sealing liquid.

A - See FIG. 29. Install one (1) 1/2" x 90° (12.7 mm) swivel street elbow, into the shaft end port of the R.H. 3" x 24" (76.2 mm x 610 mm) wing rockshaft cylinder. Connect one (1) 3/8" x 431" (9.39 mm x 10947.4 mm) hydraulic hose to 1/2" x 90° (12.7 mm) swivel street elbow. Then run the hose across the wing frame to the centre of the main frame, and to front of hitch.

B - See FIG. 29. Install one (1) 1/2" x 90° (12.7 mm) swivel street elbow, in shaft end, port of 3-1/2" x 24" (88.9 mm x 610 mm) L.H. wing rockshaft cylinder. Install one (1) 1/2" x 90° (12.7 mm) swivel street elbow, in the barrel end port of the R.H. 3" x 24" (76.2 mm x 610 mm) wing rockshaft cylinder. Connect one (1) 3/8" x 350" (9.39 mm x 8890 mm) hydraulic hose, to 1/2" x 90° (12.7 mm) swivel elbow, on R.H. cylinder. Next run the hose across frame to 1/2" x 90° (12.7 mm) swivel elbow, on L.H. cylinder.

C - See FIG. 29. Install one (1) 1/2" x 90° (12.7 mm) swivel street elbow, to barrel end port of L.H. 3-1/2" x 24" (88.9 mm x 610 mm) wing rockshaft cylinder. Install one (1) 1/2" x 90° (12.7 mm) swivel street elbow, to shaft end port of 4" x 24" (101.6 mm x 610 mm) main frame rockshaft cylinder. Connect one (1) 3/8" x 217" (9.39 mm x 5511.8 mm) hydraulic hose, to 1/2" x 90° (12.7 mm) swivel elbow, on main frame rockshaft cylinder. Next run the hose across frame to 1/2" x 90° (12.7 mm) swivel elbow on L.H. 3-1/2" x 24" (88.9 mm x 610 mm) wing rockshaft cylinder.

D - See FIG. 29. Install one (1) 1/2" x 90° (12.7 mm) swivel street elbow, into the barrel end port of 4" x 24" (101.6 mm x 610 mm) main frame rockshaft cylinder. Connect one (1) 3/8" x 24" (9.39 mm x 610 mm) hydraulic hose, to rear port of R.H. lock-up valve, with one (1) 3/8" (9.39 mm) male-female swivel. Next connect same hose to 1/2" x 90° (12.7 mm) swivel elbow, on front port of main frame cylinder.

E - See FIG. 29. Install one (1) 3/8" (9.39 mm) male x 3/8" (9.39 mm) male nipple, in the barrel end port of the rear L.H. 5" x 36" (127 mm x 914 mm) wing lift cylinder. Then install one (1) 3/8" x 3/8" x 3/8" (9.39 mm x 9.39 mm x 9.39 mm) tee, to the 3/8" (9.39 mm) union. Install one (1) 3/8" x 90° (12.7 mm) street elbow, into the shaft end of L.H. 5" x 36" (127 mm x 914 mm) wing lift cylinder.

F - See FIG. 29. Install one (1) 3/8" x 90° (9.39 mm) swivel street elbow, into the barrel end port

of the rear R.H. 5" x 36" (127 mm x 914 mm) wing lift cylinder. Install one (1) 3/8" x 90° (12.7 mm) street elbow, into the shaft end port, of rear R.H. 5" x 36" (127 mm x 914 mm) wing lift cylinder.

G - See FIG. 29. Install one (1) 3/8" (9.39 mm) male nipple into one (1) 3/8" (9.39 mm) steel cross, and fasten into the rear port of the L.H. lockup valve. Then fasten one (1) 3/8" (9.39 mm) male-female swivel into the 3/8" (9.39 mm) steel cross. Fasten one (1) 3/8" x 110" (9.39 mm x 2794 mm) hydraulic hose to the 3/8" (9.39 mm) tee on the barrel end of the rear L.H. wing lift cylinder. Fasten opposite end of same hose to the 3/8" (9.39 mm) nipple. Run this hose through the lower R.H. hole in the front wing lift cylinder lug.

H - See FIG. 29. Install one (1) 3/8" nipple in the barrel end port of the front L.H. 5" x 36" (127 mm x 914 mm) wing lift cylinder, next install one (1) 3/8" (9.39 mm) female swivel tee on same nipple. Install one (1) 1/2" x 90° (12.7 mm) swivel street elbow into the shaft end port of the L.H. 4" x 24" (101.6 mm x 609.6 mm) outer wing lift cylinder. Then install (1) 1/2" M/F, restricted swivel adapter in 1/2" x 90° elbow. Fasten one (1) 3/8" x 168" (9.39 mm x 4267.2 mm) hydraulic hose to the 1/2" x 90° swivel elbow (12.7mm) on the shaft end port of the L.H. outer wing lift cylinder. Fasten opposite end of same hose to the 3/8" (9.39 mm) female swivel tee on L.H. front inner wing lift cylinder.

I - See FIG. 29. Install one (1) 3/8" nipple in the barrel end port of the front R.H. 5" x 36" (127 mm x 914 mm) wing lift cylinder, next install one (1) 3/8" (9.39 mm) female swivel tee on same nipple. Install one (1) 1/2" x 90° (12.7 mm) swivel street elbow in the shaft end port of the front R.H. 4" x 24" (101.6 mm x 609.6 mm) outer wing lift cylinder. Then install (1) 1/2" M/F, restricted swivel adapter in 1/2" x 90° elbow. Fasten one (1) 3/8" x 168" (9.39 mm x 4267.2 mm) hydraulic hose to the 1/2" x 90° swivel elbow (12.7mm) on the shaft end of the R.H. outerwing lift cylinder. Fasten opposite end of same hose to the 3/8" (9.39 mm) female swivel tee on R.H. front inner wing lift cylinder.

J - See FIG. 29. Install one (1) 3/8" x 90" (9.39 mm x 2286 mm) hydraulic hose, to the 3/8" (9.39 mm) swivel tee on the shaft end port of the front L.H. 5" x 36" (127 mm x 914 mm) wing lift cylinder, and fasten opposite end to one (1) 3/8" (9.39 mm) steel cross, placed on the L.H.S. of the L.H. lockup valve. Fasten one (1) 1/4" x 54" (6.35 mm x 1372 mm) hydraulic hose, to the 3/8" (9.39 mm) swivel tee on the shaft end port of the front R.H. 5" x 36" (127 mm x 914 mm) wing lift cylinder and fasten opposite end of 3/8" (9.39 mm) steel cross.

K - See FIG. 29. Install one (1) 3/8" x 90" (9.39 mm x 2286 mm) hydraulic hose to the 3/8" (9.39 mm) swivel tee on center tube at rear of main frame fasten opposite end to the 3/8" (9.39 mm) steel cross on front of frame. Run hose through the lower L.H. hole in the front wing lift cylinder lug.

L - See FIG. 29. Install one (1) 3/8" x 30" (9.39 mm x 762 mm) hydraulic hose to the 3/8" (9.39 mm) swivel tee on the barrel end of the front L.H. 5" x 36" (127 mm x 914 mm) wing lift cylinder, and fasten opposite end to the 3/8" (9.39 mm) steel cross attached to the L.H. lockup valve.

M - See FIG. 29. Install one (1) 3/8" x 20" (9.39 mm x 508 mm) hydraulic hose to the 3/8" (9.39 mm) swivel tee on the barrel end of the front R.H. 5" x 36" (127 mm x 914 mm) wing lift cylinder, and fasten opposite end to the 3/8" (9.39 mm) steel cross attached to the L.H. lockup valve.

N - See FIG. 29. Install two (2) 3/8" x 172" (9.39 mm x 4369 mm) hydraulic hoses to the front port of the hydraulic lockup valves, and run hoses to front of hitch.

O - See FIG. 29. Install one (1) 3/8" x 178" (9.39 mm x 4521 mm) hydraulic hose, from the 3/8"

(9.39 mm) steel cross, to the front of disc.

P - See FIG. 29. Install one (1) 3/8" x 90" (9.39 mm x 2286 mm) hydraulic hose to the 3/8" (9.39 mm) swivel tee on shaft end of front L.H. 5" x 36" (127 mm x 914 mm) wing lift cylinder. Fasten opposite end to the 3/8" x 90° (9.39 mm) swivel street elbow into the barrel end port of the L.H. 4" x 24" (101.6 mm x 609.6 mm) outer wing lift cylinder.

Q - See FIG. 29. Install one (1) 3/8" x 90" (9.39 mm x 2286 mm) hydraulic hose to the 3/8" (9.39 mm) swivel tee on shaft end of front R.H. 5" x 36" (127 mm x 914 mm) wing lift cylinder. Fasten opposite end to the 3/8" x 90° (9.39 mm) swivel street elbow into the barrel end port of the R.H. 4" x 24" (101.6 mm x 609.6 mm) outer wing lift cylinder.

30. Securing hydraulic hoses to frame - See FIG. 29. Fasten hoses to frame with one U-shaped hose clamp at each hose hold down point. Each hold down point has a 1/2" (12.7 mm) hex nut welded to the top of frame. The hold down clips are supplied in two widths, one for two hoses and one for four hoses. Place hose clamp over hoses and fasten clamp to weld-on nut with one 1/2" x 3/4" (12.7 mm x 19.0 mm) bolt c/w lockwasher.
31. How main lift rockshaft hydraulic system works - FIG. 29. When raising the disc, oil is pumped into the barrel end port of centre frame cylinder causing the cylinder to extend. Oil is then forced from the shaft end port of same cylinder into the barrel end port of the 3-1/2" x 24" (88.9 mm x 610 mm) cylinder on L.H. side causing wing cylinder to extend. Oil is then forced from the shaft end port of the 3-1/2" x 24" (88.9 mm x 610 mm) cylinder into the piston end port of the 3" x 24" (76.2 mm x 610 mm) wing cylinder on R.H.S. causing wing cylinders to extend. The oil from shaft end port of the 3" x 24" (76.2 mm x 610 mm) cylinder on R.H.S. is returned to the tractor.

When lowering disc, oil flows from tractor to shaft end port of the 3" x 24" (76.2 mm x 610 mm) wing cylinder, causing wing cylinder to contract. Oil forced from piston end port of the 3" x 24" (76.2 mm x 610 mm) wing cylinder flows to shaft end port of L.H. 3-1/2" x 24" (88.9 mm x 610 mm) cylinder, causing cylinder to contract. The oil forced from the piston end port of the L.H. 3-1/2" x 24" (88.9 mm x 610 mm) wing cylinder flows to shaft end port of main frame 4" x 24" (101.6 mm x 610 mm) cylinder causing cylinder to contract. The oil from piston end port of the 4" x 24" (101.6 mm x 610 mm) cylinder is returned to the tractor.

NOTE: lockup valve must be open to allow oil to flow to and from lift cylinders.

All cylinders extend and contract at the same rate because the amount of oil flowing between the shaft end ports and the piston end ports is equal in volume. For example, the 4" x 24" (101.6 mm x 610 mm) main frame cylinder has a 2" (50.8 mm) diameter piston shaft which displaces enough oil from the shaft side to fully extend the 3-1/2" x 24" (88.9 mm x 610 mm) L.H. wing cylinder. The same method is used between the 3-1/2" x 24" (88.9 mm x 610 mm) L.H. wing cylinder and the 3" x 24" (76.2 mm x 610 mm) R.H. wing cylinder.

Each lift (rockshaft) cylinder contains a by-pass to allow oil to flow past piston when each cylinder is fully extended. If all cylinders are not fully extended when disc is raised, continue to pump oil into lift cylinders until all cylinders are fully extended.

32. **NOTE:** Before filling lift cylinders with oil, remove clevis pin from shaft end of each cylinder so that the cylinders may be extended and contracted **WITHOUT ACTUATING** rockshafts. Support cylinders so shafts pass over rockshaft arms and frame components.

See FIG. 29. To fill rockshaft cylinders with oil remove depth control stops to allow cylinders to work full length of stroke. Next, pump oil into the cylinders, extending cylinders. Hold hydraulic lever for (3) minutes allowing all cylinders to fully extend. Next, fully retract all cylinders then fully extend them and hold hydraulic level another (3) minutes. This procedure will purge air from all cylinders and fully synchronize them. Attach shaft end of each cylinder to rockshaft arm with one (1) 1-1/4" x 4-3/4" (31.7 mm x 121 mm) pin. Secure each pin with two (2) 5/16" x 1-3/4" (7.57 mm x 44.4 mm) cotter pins.

33. **NOTE:** Before filling wing cylinders with oil, support cylinder so shaft passes over cylinder lug on wing.

See FIG. 29. Pump oil into all 36" (914 mm) stroke wing cylinders. Extend and contract cylinder shafts until cylinders are completely filled with oil. After cylinders are full of oil, fully extend all of them. Next, place shaft end of each cylinder between two cylinder lugs on each wing frame Pin cylinder shaft to slotted hole in cylinder lugs with one (1) 1-1/4" x 4-3/4" (31.7 mm x 121 mm) pin and two (2) 1-9/32" I.D. flatwashers. Secure each pin with two (2) 5/16" x 1-3/4" (7.87 mm x 44.4 mm) cotter pins.



CAUTION

Hydraulic cylinders can be seriously damaged if clevis of shaft strikes rockshaft arm or wings cylinder lug as cylinders are being cycled to fill them with oil.



CAUTION

If hydraulic cylinder shafts are unpinned and cycled to fill the cylinders with oil, they can be seriously damaged if clevis of shaft strikes rockshaft arm or wing cylinder lug.



CAUTION

Do not disconnect hydraulically operating components under pressure may cause parts and hydraulic fluid to fly out at a high velocity which could cause serious injury



CAUTION

Hydraulic oil escaping under pressure has sufficient force to cause serious injury if injured by escaping fluid, obtain medical treatment immediately. Check hydraulic hoses periodically for signs of rupture and leaks. Use a card board as a backstop to check for escaping high pressure or hot fluid.



CAUTION

Wings will free fall if wing cylinders are not full of oil, causing serious damage.

**CAUTION**

To assemble balance of disc, extend main lift cylinders raising frame. Be sure main lift cylinders are completely filled with oil. Then place adequate support under main frame and each wing frames. Do not use lock out valve as safety device to prevent frame from falling. If any hydraulic component failed disc could drop causing serious injury or death to those nearby.

**WARNING**

Do not stand under wings while wings are being raised or lowered. If any components

34. Attaching gang assemblies - See FIG. 31

NOTE: Remove scraper assemblies and bundling tie bars from gang assemblies. The scraper assembly that is bundled with each gang will be assembled together on the disc. Be sure each gang and its scraper assembly is kept together. The 5/8" x 2" (15.7mm x 50.8mm) U-bolts used to bundle scraper assemblies must be saved to assemble scraper bar to gang beam later.

A - Using gang pattern - Identify the front and rear gangs. Next, determine which gangs are for R.H.S. and which are for L.H.S. For solid hangers L.H and R.H. is determined by the 5/8" x 10" bearing retainer bolt. When the blades are correctly orientated the double nut end of the 5/8" x 10" (15.7mm x 254mm) bolt will face the rear of the disc, see Detail B. If your disc is equipped with stone flex hangers, L.H. and R.H. can also be determined by the opening of the "C" shank. When blades are correctly orientated the open end of "C" shank will face the rear of disc, see Detail A.

B - Rear gangs - Roll rear gang assemblies in place under rear gang beams. The gang assemblies with outrigger blades (small diameter blades) must be positioned at the outside. See FIG. 30 for the direction rear gangs face.

Attach bearing hangers to gang beams with (2) two 7/8" x 6" U-bolts per bearing hanger. Details "B" and "C" illustrates how to attach solid hangers. Leave U-bolt loose. If disc is equipped with optional stone flex bearing hangers, see Step "D" to attach hangers.

C - Roll front gang assemblies in place under front gang beams. See FIG. 30 for the direction the front gangs face.

Attach bearing hangers to gang beams with (2) two 7/8" x 6" U-bolts per bearing hanger. Details "B" and "C" illustrates how to attach solid hangers. Leave U-bolts loose. If disc is equipped with optional stone flex bearing hangers, see Step "C" to attach hangers.

D - See Detail "A", FIG. 31. If disc is equipped with optional stone flex bearing hangers, fasten each spring hanger assembly, arrow 1, to bottom of gang beam, arrow 2, with one backing plate, arrow 3, and 2 U-bolts. Be sure dowel pin of backing plate, arrow 3, is installed in slot of spring shank.

E - See FIG. 31. Set front centre frame gangs, so that the leading edge of inside blades, arrow 4, are approximately 2-1/2" (63.5 mm) past centre of disc frame - centre line of centre frame is shown in FIG. 31.

IMPORTANT: Spacing between gangs, arrow "S" must not be less than blade spacing. If gangs are set too close, the gangs may interfere with each other or frame when wings are folded.

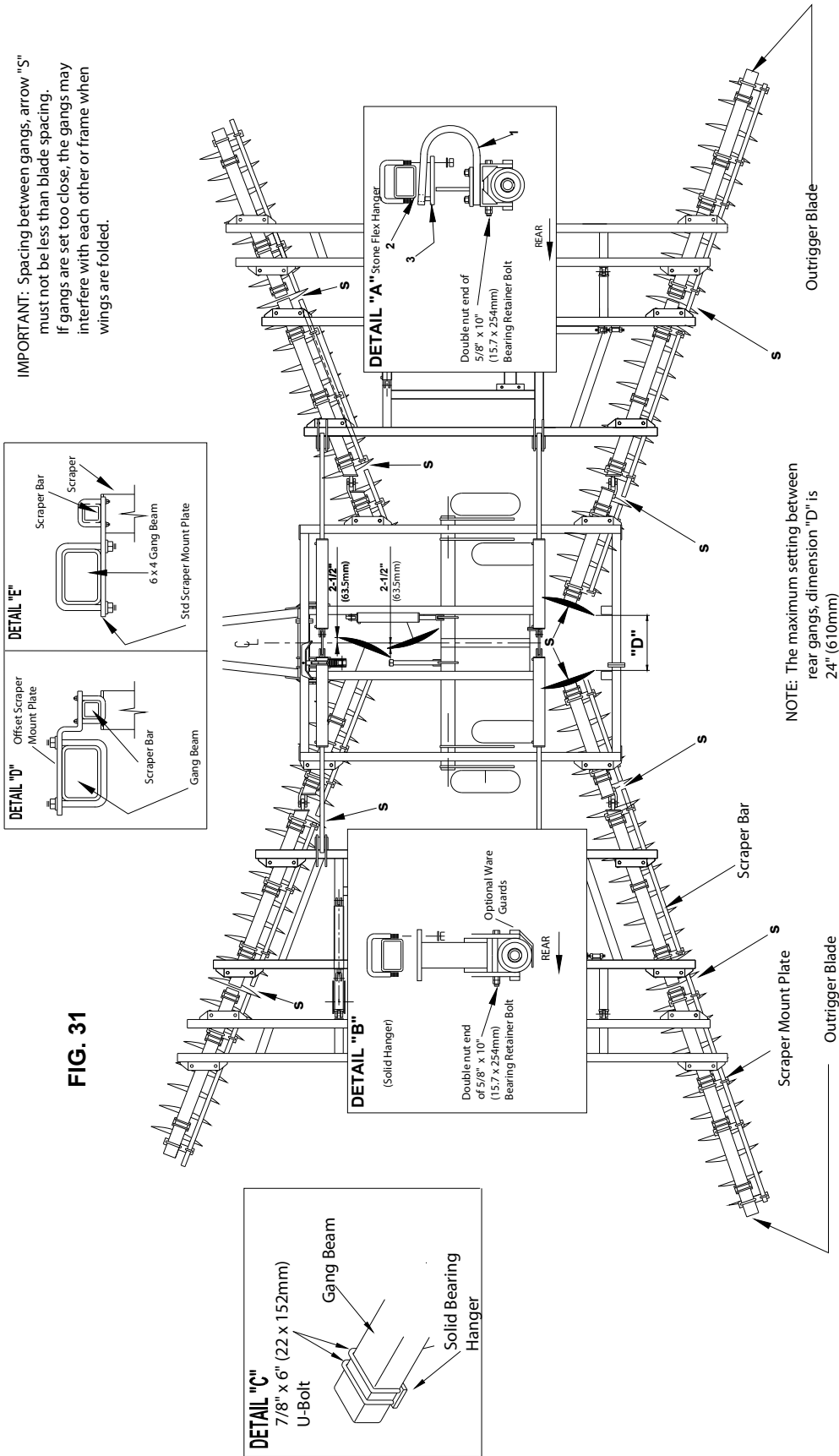

FIG. 31

F - See FIG. 31. Set rear centre frame gangs, arrow 5, so that the distance between the rear edge of the two inside blades, dimension "D" is equal to 2" (50.8 mm) less than diameter of blade to a maximum of 24" (610mm). For example, if your disc is equipped with 26" (660 mm) diameter blades, dimension "D" would be set at 24"(610 mm). If your disc is equipped with 28" (711mm) or 30" (762mm) diameter blades, dimension "D" would be set at a maximum of 24" (610mm). Be sure rear gangs are centered.

G - See FIG. 31. Adjust blade to blade distance between individual gang assemblies. This distance should be the same as the blade spacing of your disc.

NOTE: Space between wing gangs and center frame gangs must not be less than blade spacing. If gangs are set too close, the two gangs may interfere with each other when wings are folded.

H - Before tightening bearing hanger U-bolts, check each bearing hanger to make sure hanger is sitting square under gang beam. Next tighten U-bolts to 430 ft lbs (583.0 N.m).

NOTE: If bearing hangers are not sitting square before tightening u-bolts, thrust will be built into the bearings and the life of the bearing will be shortened.

35. Attaching scraper assemblies - See FIG. 31

A - Identify scraper assembly for each gang. As indicated in Section 34, the gangs were bundled with their corresponding scraper assembly. Scraper assemblies are assembled L.H. and R.H. must be installed on appropriate side.

NOTE: Some gangs use a 90° scraper. Be sure the scraper assemblies with 90° scrapers are installed on the correct gangs.

B - See FIG. 31. Position each scraper assembly on rear side of it's gang with scrapers placed against concave side of blades. Fasten scraper assembly to gang beam with one (1) scraper mount plate for each bearing hanger in the gang. Position outerscraper mount plates as close as possible to the end of the scraper bar. Position the inner scraper mount plate(s) close to a bearing hanger. Locate standard scraper mount plates on bottom side of gang beam and secure with (1) 3/4" x 6" (19.0mm x 152.4mm) U-Bolt c/w nuts and lockwashers as shown in Detail "E". Place scraper bar assembly on top of scraper mount plates and secure scraper bar to plates with one (1) 5/8" x 2" (15.7mm x 50.8mm) U-Bolts c/w nuts and lockwashers.

NOTE: In some cases the standard scraper mount plate, shown in detail "E", can not be installed between frame and a bearing hanger. In these instances an offset scraper mount is provided. This mount plate is placed on top of the gang beam, as shown in detail "D", allowing clearance for installation. All models are supplied with six (6) offset mounts. If they are not used for tight locations, use them in normal locations.

36. **NOTE:** When raising wings for transport for first time after adjusting gangs, raise wings slowly making sure wing gangs clear center frame gangs.

37. See FIG. 32. Adjust scraper bar, arrow 1, and scrapers, arrow 2, of each gang so that each scraper blade is in contact with disc blade.

NOTE: Disc will require less horse power to pull if scrapers are adjusted properly.

	<p>WARNING When attaching gang assemblies, wear protective gloves to help prevent injury from cutting edges of blades.</p>
---	---

FIG. 32

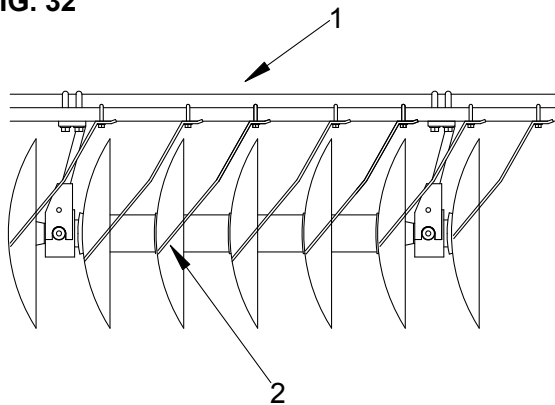
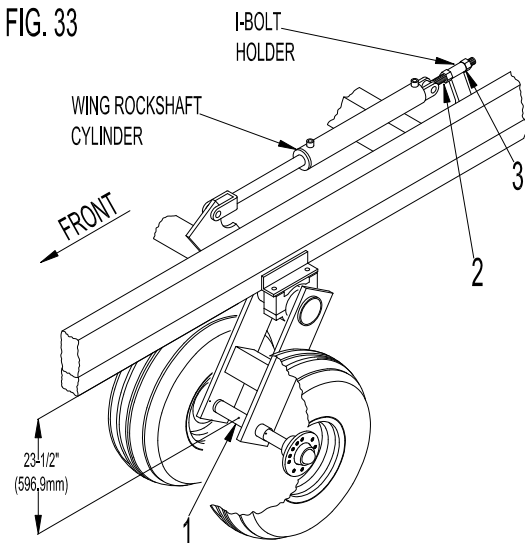

FIG. 33



38. See FIG. 33. Level frames with main frame as follows:

A - Raise disc by extending rockshaft cylinders, be sure wing rockshaft cylinders are fully extended.

B - Check position of the spindle mounting tube, arrow 1, (welded to bottom of rockshaft wheel leg). This distance should be 23-1/2" (596.9mm) from the bottom of wing frame to top of spindle mounting tube.

C - If spindle mounting tube location is not correct, adjust length of wing cylinder I-Bolt, arrow 2. Extending I-Bolt will move spindle mount tube further away from bottom of frame while contracting I-Bolt will move it closer.

D - After adjustments are complete, lock I-Bolt by tightening rear nut, arrow 3, against I-Bolt holder.

NOTE:The above wheel leg settings are initial settings only. If wing gangs do not cut at same depth as main frame gangs, further wing cylinder adjustment will be required.

NOTE: Be sure axis of clevis pin is horizontal and cylinder ports are facing up. If cylinder and I-Bolt are not positioned properly, cylinder will not be free to pivot when activated causing serious damage.

39. Warning light kit mount instructions - See FIG. 34.

**WARNING**

Do not stand under folded wings when working on disc. If hydraulic system failed or if hydraulic lever was accidentally operated, wings may fall resulting in serious injury or death to person(s) near disc.

A - With disc folded, install one lamp support bracket on each side of main frame. Locate each bracket 94" (2387mm) from rear of main frame. Fasten each lamp bracket by placing the vertical legs over the outside tube of frame. Secure with (2) 1/2" x 9" N.C. (12.7mm x 228.6mm) hex bolts c/w nuts and lockwashers. Install the bolts in the top and bottom holes of vertical legs. Tighten bolts.

B - Fasten one (1) amber lamp and one (1) red lamp to the L.H. lamp support bracket. Position amber and red lamps so they face the rear with the amber lamp on the outside. Loosen nut on stem of each lamp and insert each lamp stem into slot of bracket with nut on bottom side of bracket.

C - Fasten one (1) amber lamp to R.H. lamp support bracket. Position so amber lamp faces rear. Loosen nut on stem of lamp and insert lamp stem into outer slot of bracket with nut on bottom side of bracket.

NOTE: Paragraphs "B" and "C" and FIG. 34 describe and show lamp position for North American public roads. For other countries such as Australia, check local laws and regulations for required warning lamp mounting positions.

**CAUTION**

When transporting disc over public roads, use the smv emblem and warning lights for protection of tractor and other motor vehicle operators. Check local laws for width and height maximums.

F1 - See FIG. 35 - Lay wiring harness on hitch and center frame with 7 pin male plug, arrow 4, located at front of hitch.

The wiring harness is tagged L.H.S. (left hand side) and R.H.S. (right hand side) at outer plugs. When laying harness on frame ensure L.H. end of harness is placed on L.H.S. of main frame and R.H. end is placed on R.H.S. of frame. L.H. and R.H. is determined by view of disc from rear.

NOTE: The R.H. and L.H side of harness must be properly positioned to allow signal light to work properly. Run harness along lamp support brackets. Tie harness to frame and lamp support as required with the straps. Next plug in each amber lamp to two wire plug, arrow 2, at outer ends of harness. Plug in red lamp to a 3 wire plug, arrow 1.

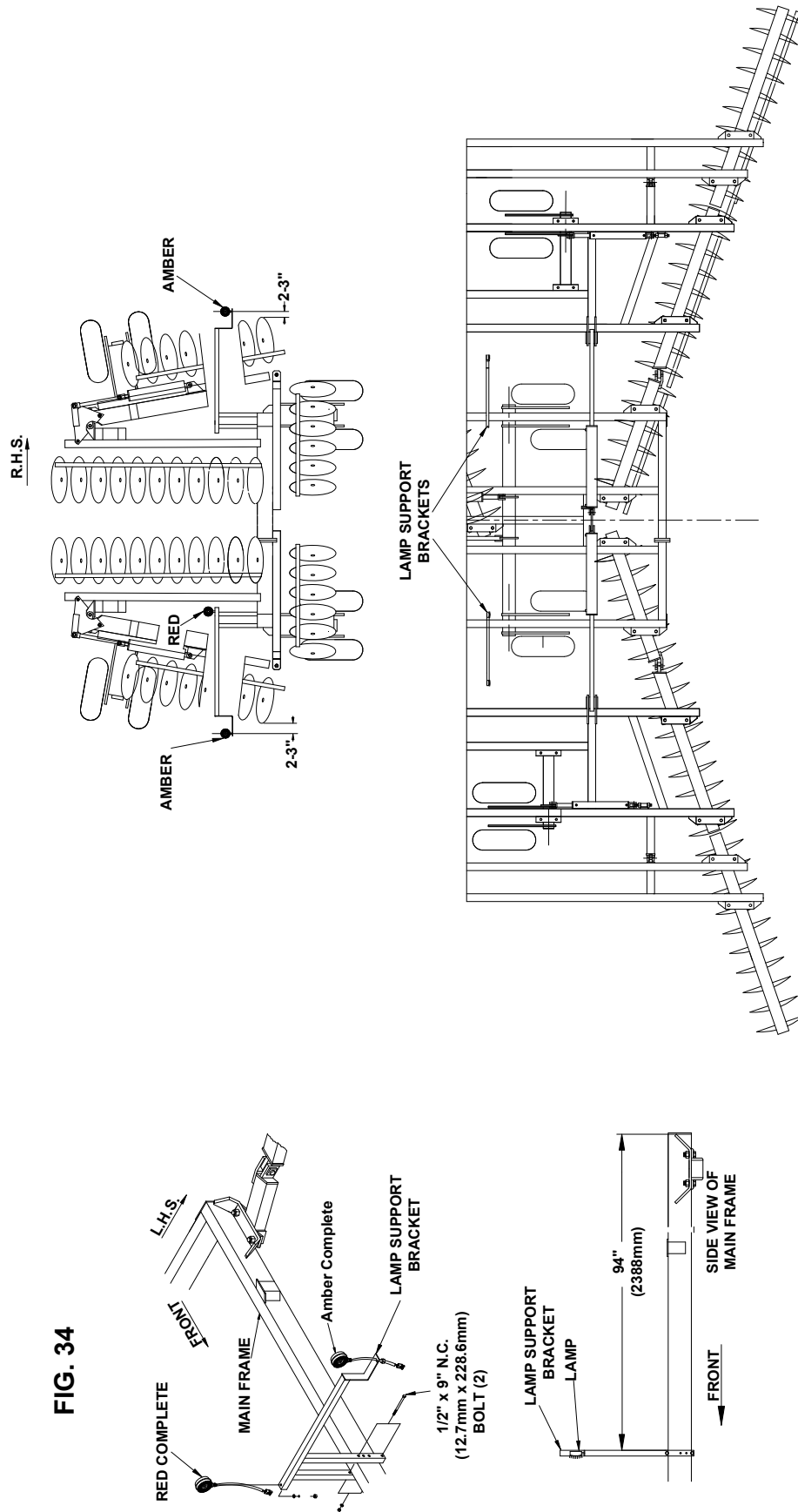
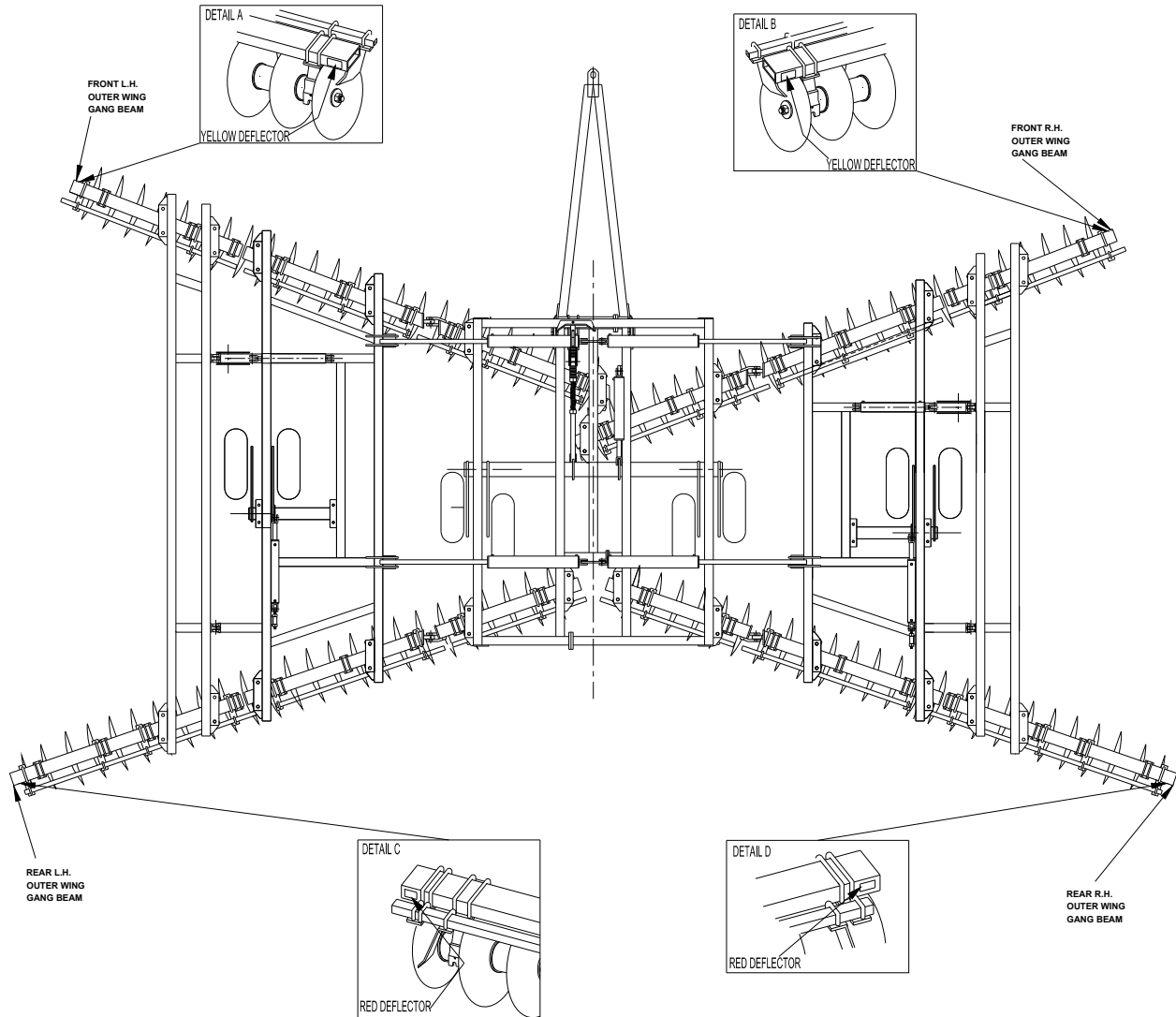

FIG. 34

FIG. 36



40. Reflector decal installation - See FIG. 36.

NOTE: Before installing decals, clean the area they will be placed on.

A - Place one 2" x 9" (50.8 mm x 228.6 mm) red reflector decal on rear side of each rear gang beam. Locate decals approximately 1" (25.4 mm) from end of gang beam. See detail "C" and "D".

B - Place one 2" x 9" (50.8 mm x 228.6 mm) yellow reflector decal on front side of each front gang beam. Locate decals approximately 1" (25.4mm) from end of gang beam. See detail "A" and "B".

Gang Beam Chart

Disc Model	L.H. & R.H. Front Center Frame Beam	L.H & R.H. Rear Center Frame Beam	L.H. & R.H. Front Inner Wing Frame Beam	L.H. & R.H Rear Inner Wing Frame Beam	L.H. & R.H. Front Outer Wing Frame Beam	L.H. & R.H. Rear outer Wing Frame Beam
------------	-------------------------------------	-----------------------------------	---	---------------------------------------	---	--

10-1/2" Spacing						
86 Blade	86-1/2"	69-1/2"	87-1/2"	86"	56"	83"
90 Blade	86-1/2"	69-1/2"	87-1/2"	86"	64"	93"
94 Blade	86-1/2"	69-1/2"	87-1/2"	86"	74"	104"
98 Blade	86-1/2"	69-1/2"	87-1/2"	86"	84"	113"

12" Spacing						
78 Blade	86-1/2"	69-1/2"	87-1/2"	86"	56"	93"
82 Blade	86-1/2"	69-1/2"	87-1/2"	86"	68"	104"
86 Blade	86-1/2"	69-1/2"	87-1/2"	86"	70"	116"

Gang Pattern - 10-1/2" Spacing - 86 Blades/32 Bearings - Approx. 37' Wide

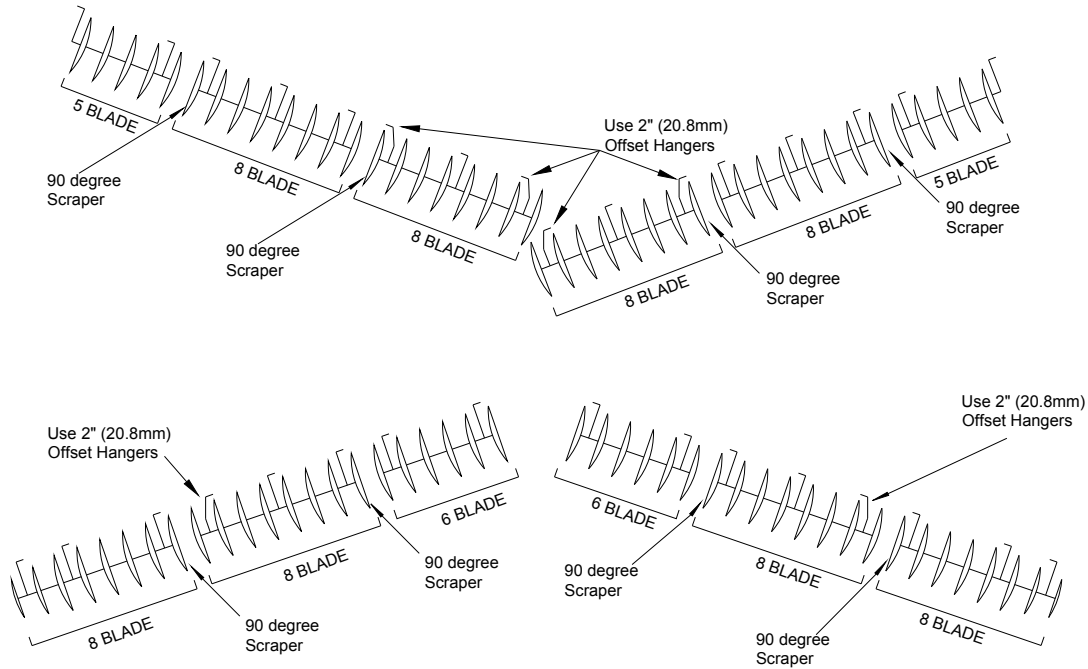

Gang Pattern - 10-1/2" Spacing - 90 Blades/32 Bearings - Approx. 38-1/2' Wide

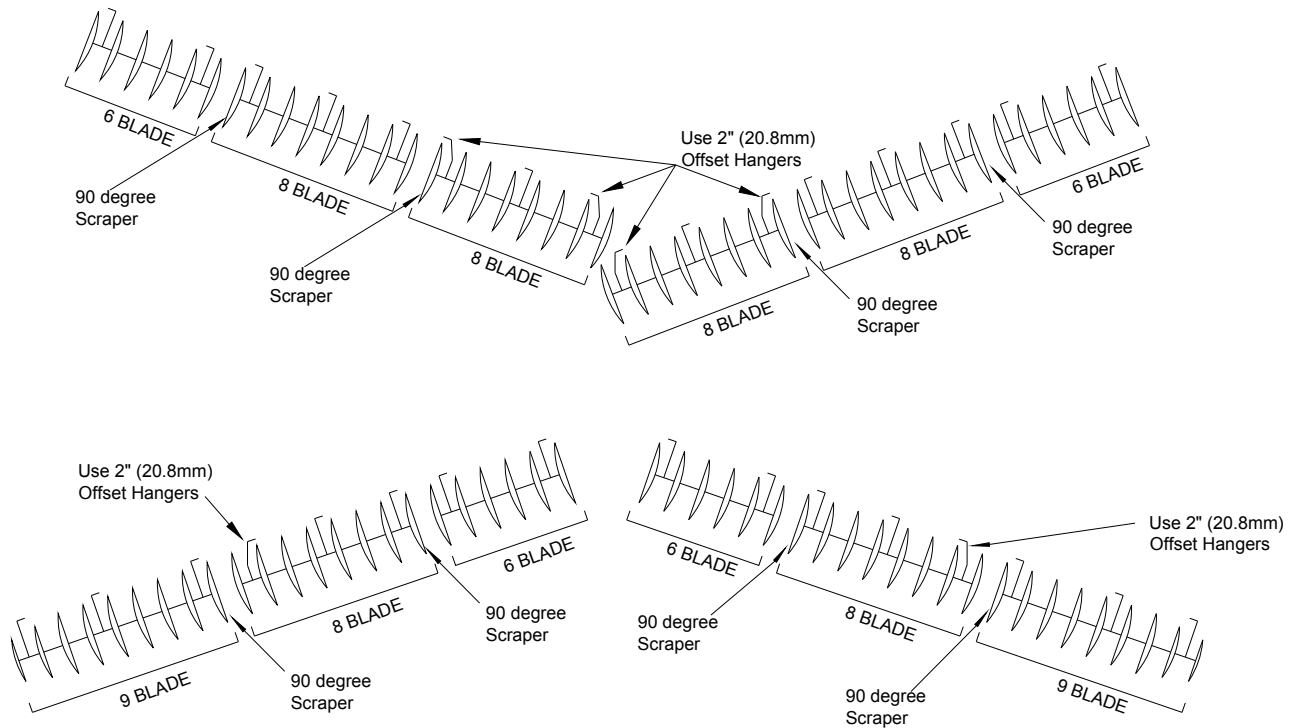

Gang Pattern - 10-1/2" Spacing - 94 Blades/34 Bearings - Approx. 40-1/2' Wide

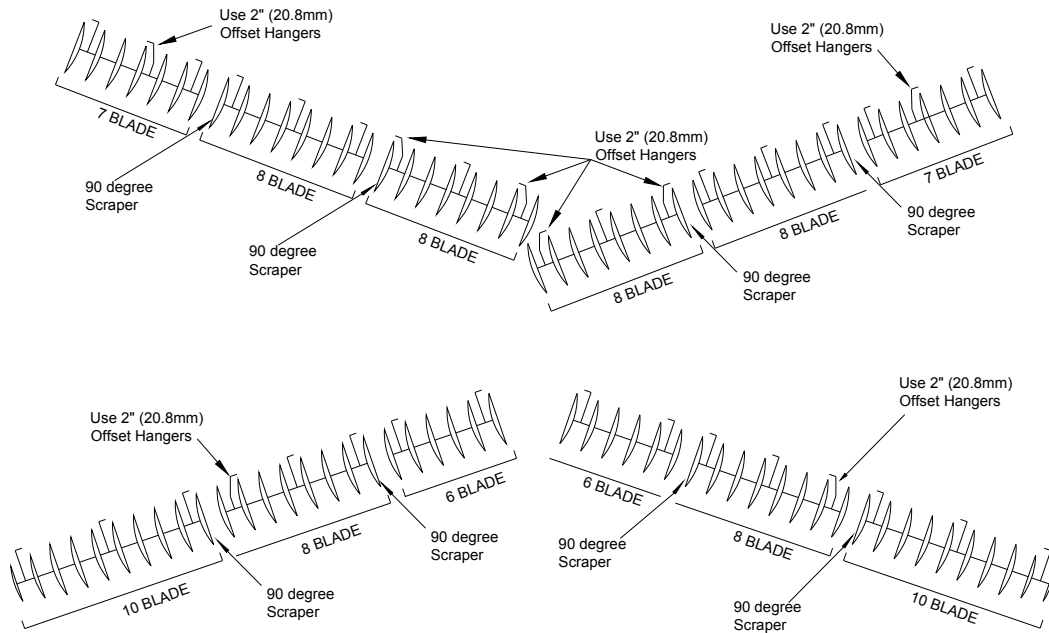

Gang Pattern - 10-1/2" Spacing - 98 Blades/36 Bearings - Approx. 42' Wide

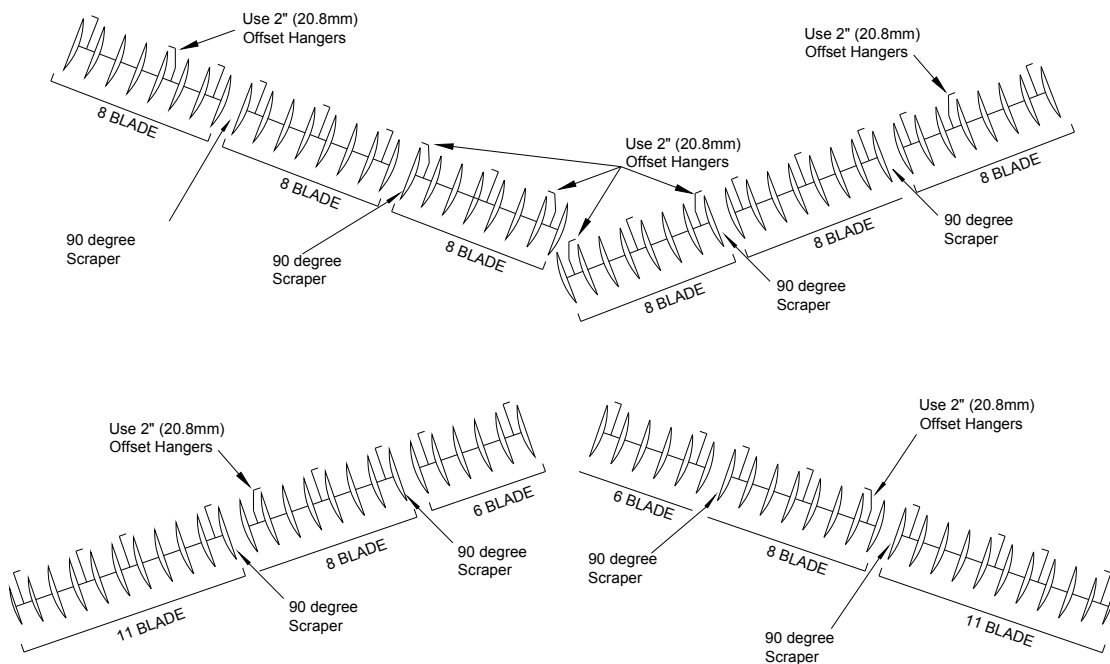

Gang Pattern - 12" Spacing - 78 Blades/34 Bearings - Approx. 38-1/2' Wide

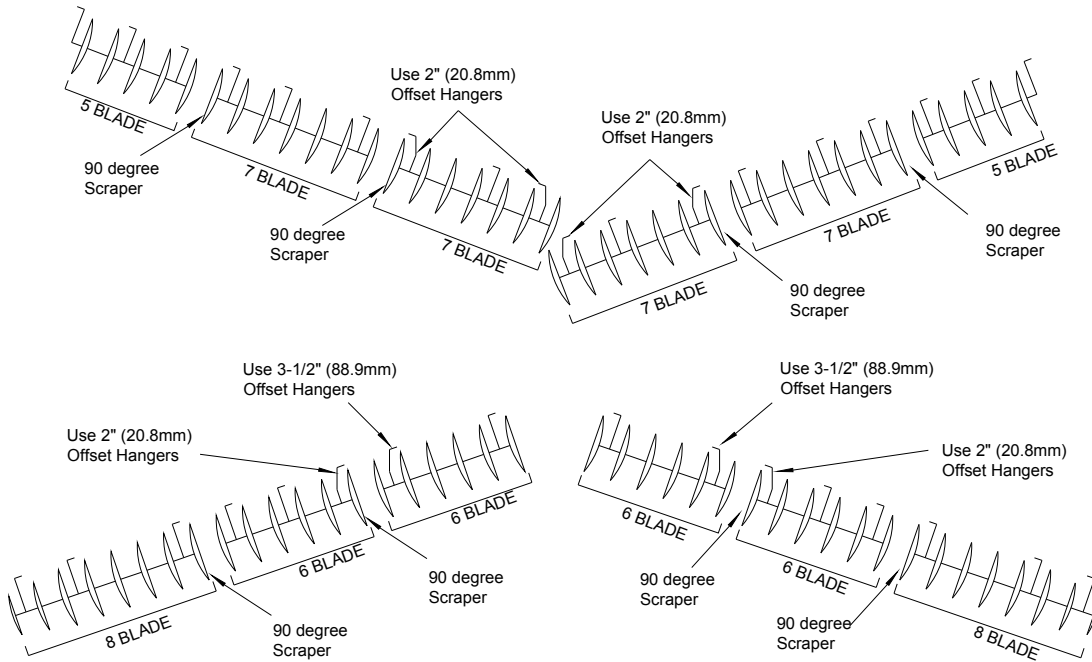

Gang Pattern - 12" Spacing - 82 Blades/34 Bearings - Approx. 40-1/2' Wide

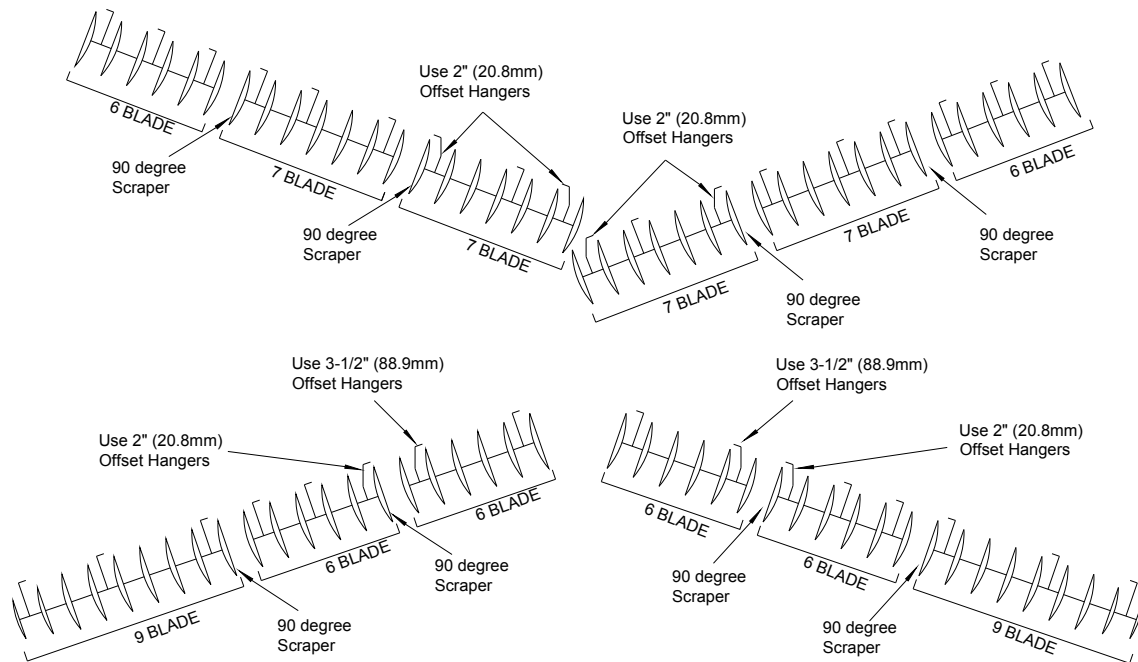

Gang Pattern - 12" Spacing - 86 Blades/34 Bearings - Approx. 42-1/2' Wide

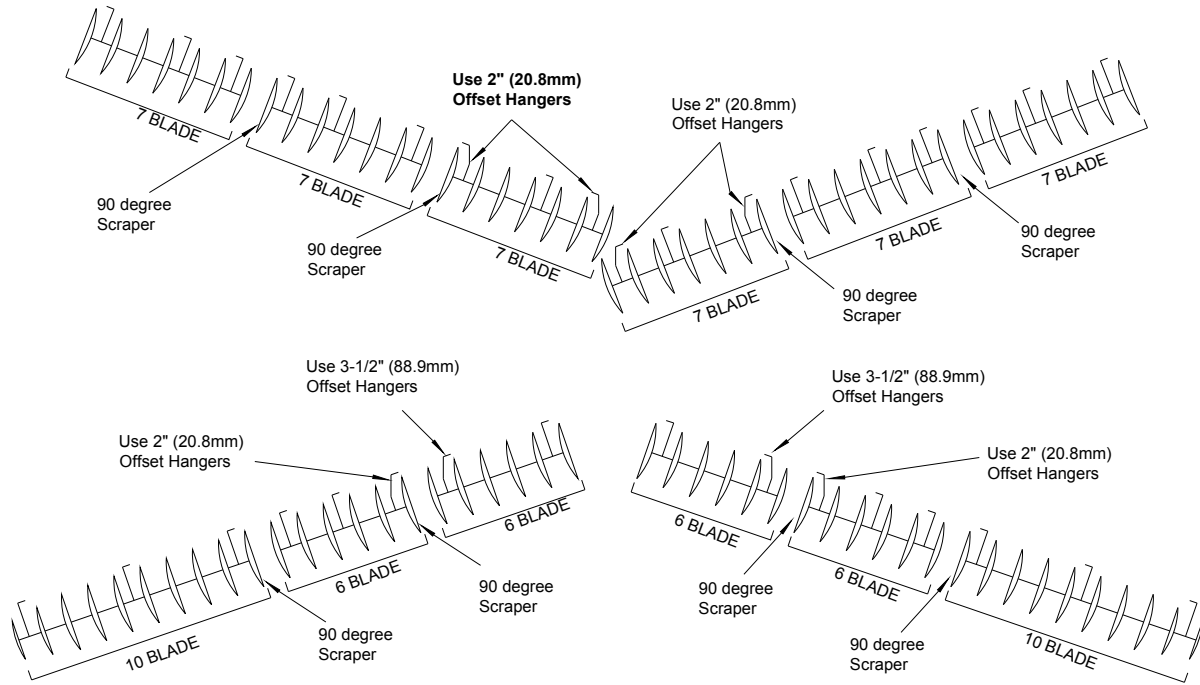

Operation Instructions

1. Before operating disc, familiarize yourself and other operators with all of the Safety Precautions of this Manual. Review safety items applicable to both road transport and field operation of this disc.
2. This machine is a primary tillage implement. By reviewing the recommendations contained in the paragraphs A to J its performance will be enhanced.

A - When lowering wings into working position, be sure wing lift cylinders are fully extended. After wing frame wheels have contacted the ground, continue holding hydraulic control lever for approximately 10 to 15 more seconds.

NOTE: the wing lift cylinders will be fully extended when the outer cylinder pins are approximately at the mid-point position in their slots. If cylinders are not fully extended, wing frames will "hang" and will not permit any downward flex.

B - For best performance, ensure drawbar is pinned at centre of tractor.

C - Check to ensure disc is level both fore and aft and side to side.

D - See FIG. 1. To set working depth, lower disc slowly while moving forward with tractor. Once desired working depth is reached, stop tractor and install required number of depth control stops (on main frame lift cylinder) to maintain this desired cutting depth.

FIG. 1

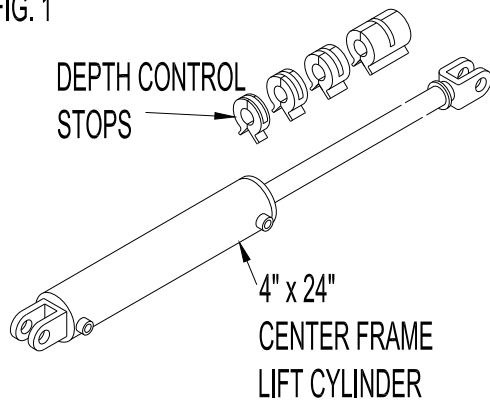

E - Always lift disc before making sharp turns in the field. Sharp turns can seriously damage gang components in addition to leaving an uneven field finish.

NOTE: Always lift disc before making sharp turns in field. Excessive side thrust can damage gang components such as bearings, blades, etc. If discs is not lifted out of ground.

F - The optimum working (field) speed for this disc is 4 to 4.5 MPH (6.4 to 7.2 KMH). Excessive speed will cause ridging and damage to disc gangs and/or frame in rocky conditions.

G - Rephasing rockshaft cylinders - Periodically, the hydraulic lift cylinders on either wing frame will not be synchronized with main frame cylinder and this will result in an uneven working depth across the implement. If this occurs, it will be necessary to re-phase the entire lift cylinder system. Re-phasing is accomplished by lifting the entire disc completely out of the ground and holding the hydraulic control lever until all of the rockshaft cylinders (3) are fully extended. Hydraulic oil must travel through the entire system to “phase” cylinders properly therefore it is very important when attaching your tractor hydraulics that any air that may be in the system is taken out or “purged”. The hydraulic lift system is purged by lifting implement and holding the hydraulic lever for three (3) minutes. Implement should then be lowered and then raised again by engaging hydraulic lever for another three (3) minutes.

NOTE: If air is left in the re-phrasing hydraulic system, several things can happen. When implement is lowered to the ground, one of the wing rockshaft wheels may not move immediately or lag behind the other. Another symptom of air in the system is if any of the cylinders “creep” off the stop. Air acts like an invisible spring and when the weight is taken off the cylinder, this “spring” pushes the cylinder out. Most series hydraulic system problems are due to air in the system. When operating this disc, it is recommended practice to raise the machine to its full height and hold lever for several minutes several times during the day, such as when it is raised to make a turn. This will supply oil to continually purge the system of air when cylinders are completely extended. When relieving the pressure in the hydraulic system or when uncoupling the hydraulic tips, lower implement with the tractor running until the cylinders reach the depth stops. If the machine is lowered with the tractor not running, no oil is pumped back into the system thereby causing the possibility of air getting back into the rephrasing system.

**CAUTION**

When operating on hillsides, always use extra care. Tractor may roll if it encounters a hole, ditch or other irregularity.

NOTE: Do not operate disc when front gangs are cutting deeper than rear gangs. Disc must be level. If front gangs are lower, excessive strain will be placed on blades, gang bearings and frame hitch, which could lead to premature failure of components such as blades and bearings of front gangs.

NOTE: Never operate disc in field with wings folded in transport position. If disc is operated in this manner, excessive weight on main frame will result in premature failure of frame and gang components. Warranty is expressly denied if this occurs.

K - To avoid serious damage to hitch jack, ensure it is locked in horizontal position when disc is moved or being operated.

FIG. 2

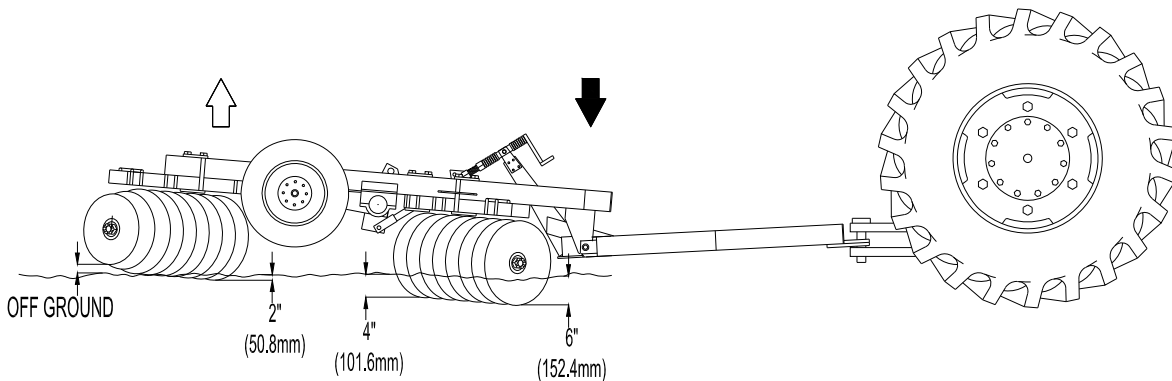

INCORRECT - WHEELS OFF GROUND

FIG. 3

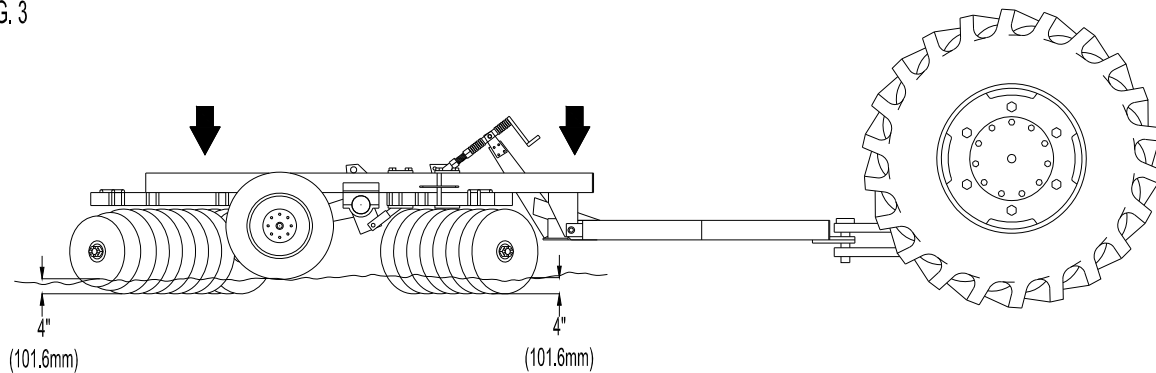

CORRECT - WHEELS ON GROUND GAUGING DISCING DEPTH

L - To keep disc level, do not operate with wheels off the ground as shown in FIG. 2.

If conditions are such that disc cannot penetrate to maximum depth, raising transport wheels off ground as shown in Fig. 2 is NOT recommended. Raising transport wheels off the ground will cause the front of disc to drop thereby causing front gangs to cut deeper than rear gangs. As the wheels are raised, the hitch leveling arm is pulled back allowing hitch to float. Since the rockshaft and the hitch leveling arm are linked, the front of the disc will drop.

When hitch is “floating”; it does not support the front of disc thereby allowing the disc to drop.

With front of disc lower than the rear, the front outside blades will cut considerably deeper than the center blades. This results in most of the weight of the disc being placed on the outer front gangs, forcing them deeper into the ground.

NOTE: Operating disc with transport wheels off ground will result in an uneven field finish and places undue strain on machine which could lead to premature failure. Always operate disc with transport wheels on ground even if soil conditions will not allow disc to penetrate to maximum depth.

3. See FIG. 4. When transporting disc, always place Hydraulic Lock-up Valves in "closed" position. Lockup valves are located at the front end of centre frame.

**CAUTION**

When transporting disc always place both hydraulic lock-up valves in closed position. If hydraulic lever was accidentally operated the disc could drop or wings could fall causing serious injury or death to operator or persons(s) nearby.

4. When transporting disc, do not exceed speed of 20 mph (32 km/h). Reduce speed in hilly or uneven terrain.

**CAUTION**

Do not exceed 20 mph (32 km/h) when transporting disc on smooth roads. Always reduce speed when transporting on rough roads. Excessive speed could cause loss of tractor control and damage to disc and tractor. Do not transport disc with any other vehicle except a tractor.

**WARNING**

When transporting disc, always install the complete set [17" (432 mm)] of depth control stops on shaft of center frame cylinder. If any component of hydraulic system failed, the disc could suddenly drop causing serious injury or death to operator or person(s) near-by.

5. **NOTE:** Do not operate hydraulic lift cylinders to raise disc if blades are frozen to ground. Attempting to lift disc out of frozen ground can cause serious damage to main lift cylinders and/or rockshaft cylinder arms. When disc is being stored for winter, do not allow blades to contact ground that may freeze. Leave disc parked on transport wheels.
6. See FIG. 5. Attach a Safety Chain to the tractor drawbar and to the hitch of disc before transporting. Use a chain with strength rating greater than the gross weight of disc. (Safety chain available as an option).

**DANGER**

Before transporting disc, be sure to attach a safety chain to tractor drawbar and disc hitch. The safety chain will help control the disc should it accidentally separate from the drawbar of the tractor use a chain with a strength rating greater than the gross weight of the towed implement. Serious damage, injury or death could result if the disc separated from the tractor drawbar.

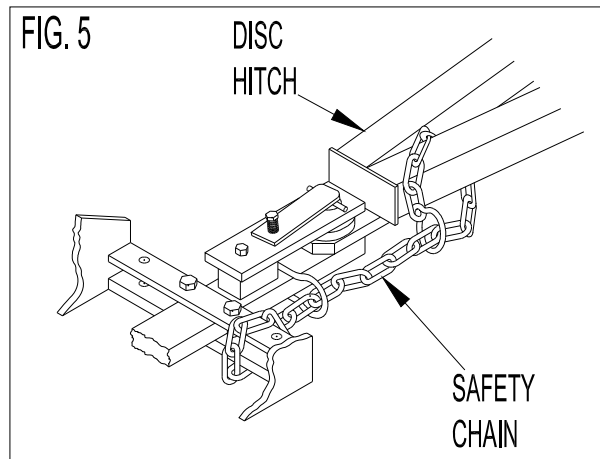
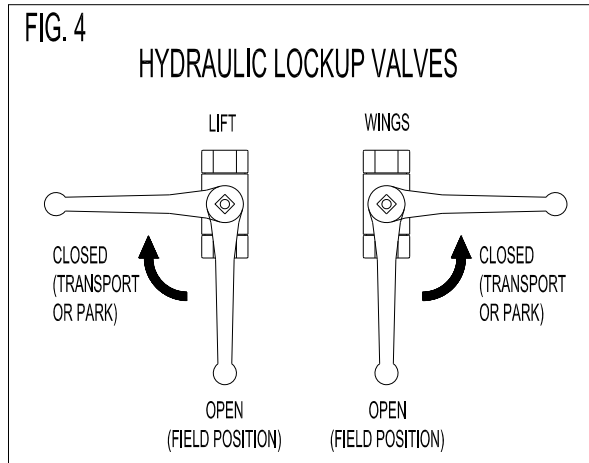



DANGER See FIG.6. Do not stand under the wing(s) while it is being folded or unfolded. If any component of the hydraulic system failed or if the hydraulic lever was accidentally operated, wing(s) could fall causing serious injury or death.

7. See FIG. 7. Install the slow moving vehicle emblem (SMV) in bracket welded to the R.H. rear center frame before transporting the disc.



CAUTION Use the slow moving emblem (SMV) and warning lights for the protection of tractor operator and other motor vehicle operators when transporting the disc over public roads or highways. Always check local laws regarding transporting regulations.



CAUTION When transporting the disc over public roads or highways, always check local laws regarding width, height and weight restrictions.

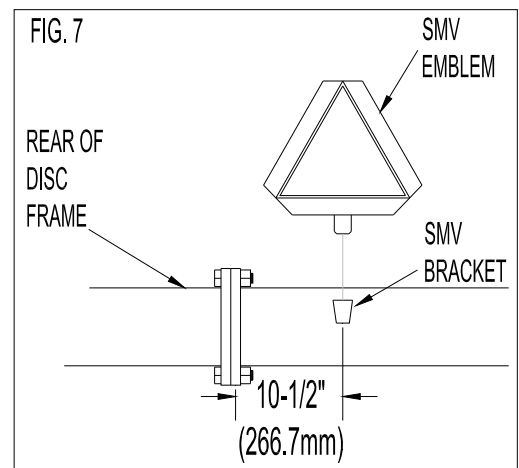
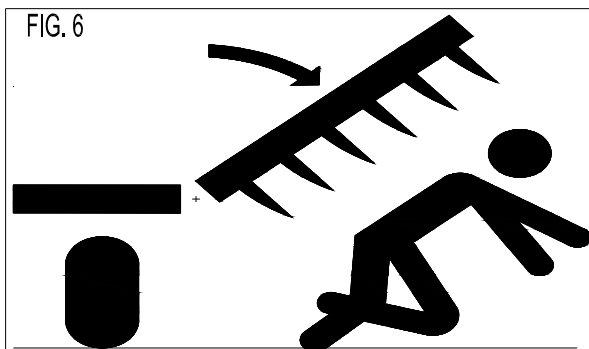

**DANGER**

When transporting disc, always ensure there is sufficient clearance under overhead obstructions. Serious injury or death can result from contact with high voltage electrical lines when moving or operating disc. Models equipped with folding gang beams must be fully folded to give minimum transport height.

**WARNING**

When transporting disc, always place hydraulic lock-up valves in closed positions. If the hydraulic lever was accidentally operated, the disc could suddenly drop or wings could fall causing serious injury or death to operator or person(s) nearby.

**WARNING**

Never allow anyone to ride on drawbar of the tractor or on the disc. There person riding may fall and be seriously injury.

**WARNING**

Always lower the disc to the ground when servicing or making adjustments. If the disc must be serviced or adjusted in the raised position, make sure frame is adequately blocked. Do not rely on hydraulic lock-up valves as a safety device. If any component of the hydraulic system failed, or if the hydraulic lever was accidentally operated, the disc could drop suddenly.

8. **IMPORTANT:** When parking or storing disc, always relieve pressure in hydraulic cylinders. Hydraulic cylinder or other components could fail if thermal expansion of hydraulic oil takes place due to warmer weather or if disc is stored in heated building.

Adjustments

1. Lateral adjustment of the front and rear gangs

A - Front gangs - See FIG. 8 - Loosen bearing hanger U-bolts and adjust front gangs so that leading edge of inside blades are, arrow 1, approximately 2-1/2" (63.5 mm) past centre of disc. The centre line of disc is shown in Fig. 8. If the above adjustment is made correctly, the front gang will not leave any unbroken ground in the middle of disc.

B - See FIG. 9 - To adjust rear gangs, loosen bearing hanger U-bolts.

The opening between the rear gangs Dimension "D" must be set at a distance that will allow furrow left by the front gangs to be filled evenly. The distance the rear gangs are set apart is determined by the operating speed, working depth, gang angle and soil conditions. If rear gangs are set too close together, the rear gangs will leave a ridge at center. If rear gangs are set too far apart, the center furrow (from the front gangs) will not be filled. It is important to note of the amount of soil the rear inside blades are picking up. It may be necessary to increase the distance between rear gangs in order to collect enough soil to fill the furrow. Initially, this distance should be set at 2" (50mm) less than diameter of blades to a maximum of 24" (610mm). For example, if disc is equipped with 26" (660 mm) blades, the opening (Dimension "D") should be 24" (610 mm). If your disc is equipped with 28" (711mm) or 30" (762mm) diameter blades, Dimension "D" would be set at a maximum of 24" (610mm).

An increase in working speed may required rear gangs to be set further apart. A decrease in working speed may require rear gangs to be set closer together.

NOTE: Be sure distance between blades on adjacent gangs are adjusted to match the blade spacing of your disc.

C - When adjustments to gangs are complete, U-Bolts on bearing hangers can now be tightened. Ensure that each bearing hanger is positioned flat under the gang beam to avoid preloading either bearings and/or other gang components. Tighten hanger U-Bolt to 430 ft lbs (583.0 N.m).

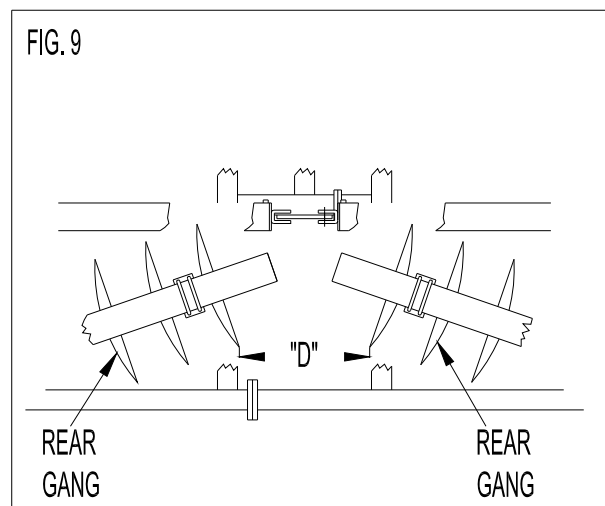
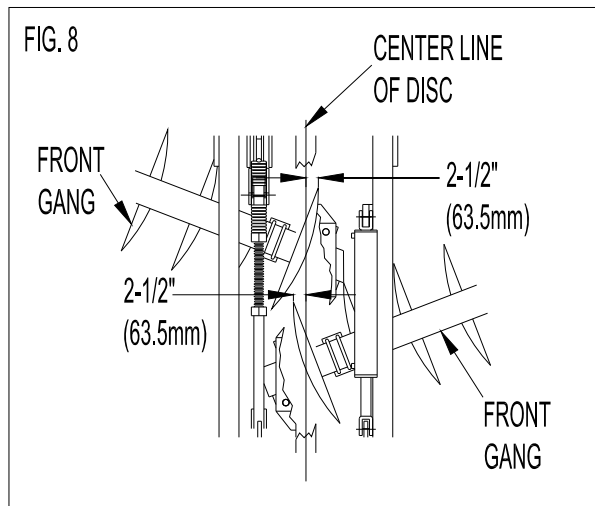

2. Leveling disc - front to rear - See FIG. 10. When disc is being operated, both front and rear gangs should be cutting at same depth. Use leveling crank, arrow 1, to level disc.

To lower front gangs: Turn crank, arrow 1, IN (clockwise)

To raise front gangs: Turn crank, arrow 1, OUT (counter clockwise)

IMPORTANT: Always keep disc level front to rear. Operating disc with front gangs lower than gangs will cause ridging at outside and may cause damage to disc components.

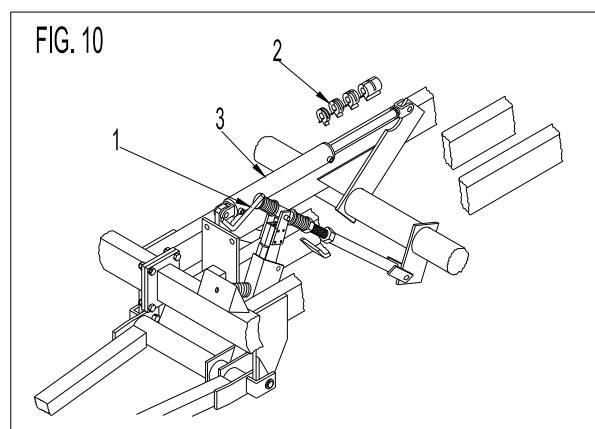

3. Setting working depth - See Fig. 10. To set depth of cut, lower disc into the ground while moving forward until disc reaches desired working depth. Install the necessary depth control stops on centre frame cylinder to maintain the desired cutting depth.
4. Leveling wing frames - See FIG. 11. Before this adjustment is made, be sure centre frame is level front to rear. After adjustments are complete tighten nuts on cylinder I-Bolt.

For even blade penetration, outside of wing frames must be level with centre frame or even 1/2" (12.7 mm) higher than centre frame.

To level either wing frame with centre frame, adjust wing rockshaft cylinder I-Bolt, arrow 1. If outside of wing frame needs to be raised, loosen rear nut of I-Bolt and tighten front nut. This will lower the wheels and raise outside of wing. If outside of wing frame needs to be lowered, loosen front nut of I-Bolt and tighten rear nut. This will raise the wheels and allow outside of wing to operate lower.

NOTE: Be sure axis of clevis pin on wing rockshaft cylinders are horizontal with cylinder ports facing up. If clevis pin is not positioned properly, cylinder will not be free to pivot when activated, causing serious damage.

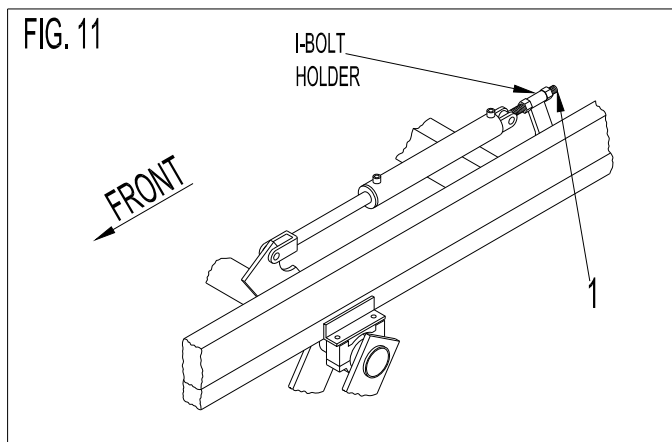

CAUTION

Always place tractor controls in neutral and lock brakes to avoid tractor accidentally rolling backwards when attaching disc.



CAUTION

When operating on hillsides, use extra care. Tractor may tip sideways if it strikes hole, ditch or other irregularity.

5. To remove balk center of disc: Make one or more of the following adjustments:
 - A** - Level disc from front to rear using leveling crank, see section 3 of adjustments.
 - B** - Reduce working speed.
 - C** - Increase distance between rear gangs, see section 1 of adjustments.

6. To remove furrow at center of disc - Make one or more of the following adjustments:
 - A** - Level disc from front to rear using leveling crank, see section 3 of adjustments.
 - B** - Increase working speed.
 - C** - Decrease distance between rear gangs, see section 1 of adjustments.

7. To remove unworked soil left by front gangs: Make the following adjustments:
 - A** - Adjust leading edge of inside blade of each overlapping front gangs so it is 2-1/2" (63mm) past centre of disc, see section 1 of adjustments.

8. To reduce gang plugging: Make the following adjustment:
 - A** - Adjust scrapers so they contact blades.

Maintenance

1. Lubrication - See FIG. 12 - All grease lubricating points on disc are marked with arrow G. The oil lubrication points are marked with arrow O.

G1 - Gang bearing - for T2-215 Series Gang Bearing - Lubricate every 20 hours of operation. Lubricate until grease comes out around seal. Excessive lubrication will not damage seals. Use high quality SAE multi-purpose grease.

G2 - Lubricate leveling crank every 100 hours of operation.

G3 - Lubricate wheels every 50 hours of operation.

G4 - Lubricate top and bottom half of each rockshaft bearing every 20 hours of operation.

G5 - Lubricate wing hinge points every 100 hours of operation.

G6 - Lubricate walking axles every 50 hours of operation.

NOTE: When you receive your new disc, grease all lubricating points before starting to disc.

O1 - Lubricate leveling crank ball joint (with oil) at the end and beginning of each season.

O2 - Lubricate rockshaft cylinder pins (with oil) every 50 hours of operation.

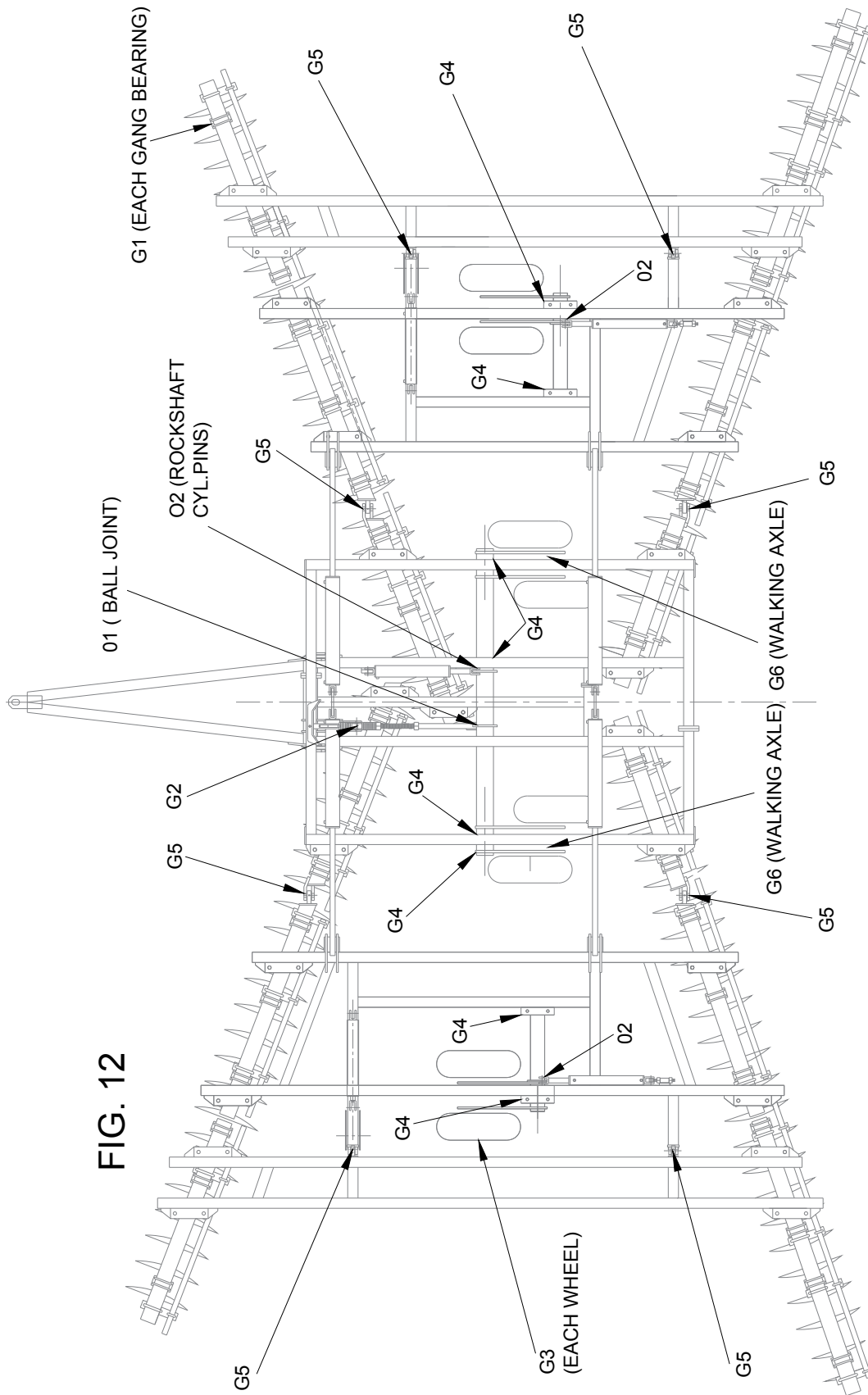

FIG. 12

2. All bolts and nuts should be checked periodically to make sure they are tight. Special attention should be given to gang bolts, bearing bolts and bearing hanger U-bolts, and wheel bolts.

They should be tightened as follows: Gang bolts 1-15/16" (49 mm) diameter -tighten to 3200 ft lbs torque (4339 N.m)

See FIG. 13. To tighten gang bolt to 3200 ft. Lbs (4339N.m) install a 10ft (3.05m) bar in socket wrench and apply 320 lbs (145Kgs) of force to end of bar.

NOTE: After repairing a gang, the gang bolt should be retightened after 2 hours of operation.

IMPORTANT: Severe damage will occur if gang bolts are loose.

Gang bolts - 1-1/4" (31.7 mm) diameter - 840 ft lbs (1139 N.m)

Leveling crank bolt - 1-1/4" (31.7 mm) diameter - 840 ft lbs (1139 N.m)

Wheel bolts 9/16" (14.2 mm) diameter - 150 ft lbs (203 N.m)

Bearing hanger u-bolts 7/8" (22 mm) diameter - 430 ft lbs (583.0 N.m)

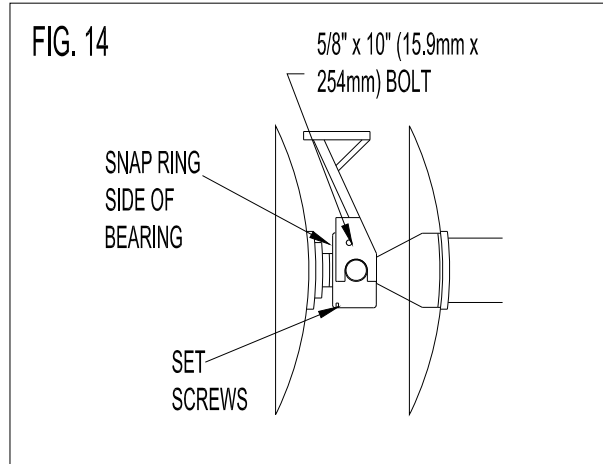
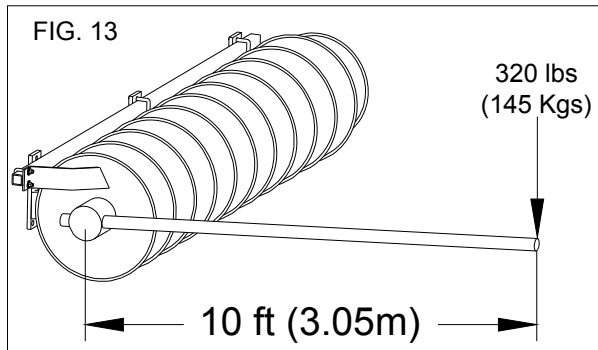

3. When storing disc for a long period of time, grease all lubricating points.

4. **IMPORTANT:** See Fig. 14

A - If T2-215 bearing must be dismantled, ensure double set screws are removed from bottom of housing to remove seal cap.

B - When replacing grease seals in T2-215 bearing, ensure they are installed correctly. The I.D. of the outer shield is larger on one side than the other. Be sure the side with the larger I.D. of both seals are facing outward. The rubber seal may be damaged if grease seal is not installed correctly.

	<p>CAUTION</p>	<p>Do not service disc while it is in motion. You may fall in front of disc and be seriously injured.</p>
---	-----------------------	---



CAUTION

Lower the disc to the ground when servicing or making adjustments. If the disc must be serviced or adjusted in the raised position, place blocks under frame. Do not rely on hydraulic lock up valves as a safety device. If hydraulic system failed, the disc could drop.

5. See FIG. 14. When reinstalling bearing hanger on T2-215 Bearing (if gangs are dismantled) do not over tighten the 5/8" x 10" (15.7 mm x 254 mm) bolts that attaches bearing to hanger. Tighten lock nut only until it is snug against bearing hanger. Over tightening this bolt may cause it to break during field operations.
6. Wing lift cylinder removal - See FIG. 15. If possible lower wings to field position if the wing lift cylinder hydraulic system must be serviced or repaired. If wing lift cylinders must be serviced or repaired with wings in folded position, install a safety chain between each wing frame and main frame to prevent wings from falling down. Always install a chain on both wings even if only one cylinder is being worked on.

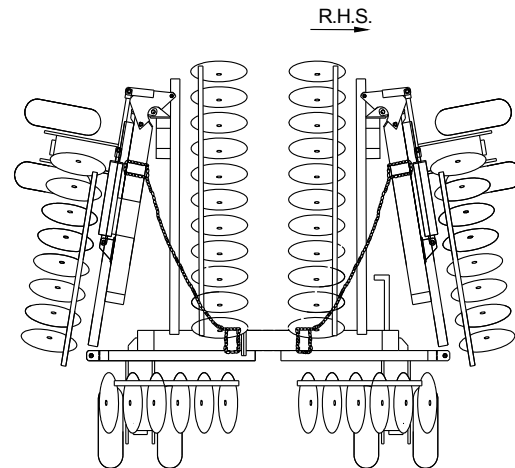

Fig 15.



CAUTION

If wing lift cylinder(s) or wing lift hydraulic hoses are removed when wings are folded into transport position, always install a safety chain between each wing frame and main frame to prevent wings from falling. If wings fell serious injury or death could occur to person(s) nearby and machine would be damaged seriously.

7. Keep all safety decals clean and in good condition to provide a constant reminder of safe operating procedures.
8. Replace any destroyed, missing or illegible decals and reflectors.
9. At the end of each season do following:
 - A - Relieve pressure in all hydraulic cylinders. Disconnect hydraulic hoses from tractor and cap them.
 - B - If disc is to be stored outdoors, cover hydraulic cylinders and hoses with weather proof material and coat all exposed cylinder shafts with grease.
 - C - Set planks under each wheel.
 - D - Lubricate all grease points.

E - Check disc for worn or damaged parts. Replace damaged parts during the off season.

F - Touch up any scratches with paint.



CAUTION

Always relieve the pressure in hydraulic system and close both hydraulic lockup valves when disc is not being used.

G - IMPORTANT - When storing disc do not leave cylinders under hydraulic pressure, especially if cylinders are activated during cool temperatures. The thermal expansion of oil which takes place when the machine is in a warmer environment may cause serious damage to cylinders or hoses. Always release hydraulic pressure and close lockup valves before unhitching from tractor.



CAUTION

Wings may unfold due to thermal expansion of hydraulic oil causing damage to cultivator, property or severe injury or death to person(s) nearby. Release pressure in all cylinders and close hydraulic lockup valves before unhitching from tractor or when parking with tractor.

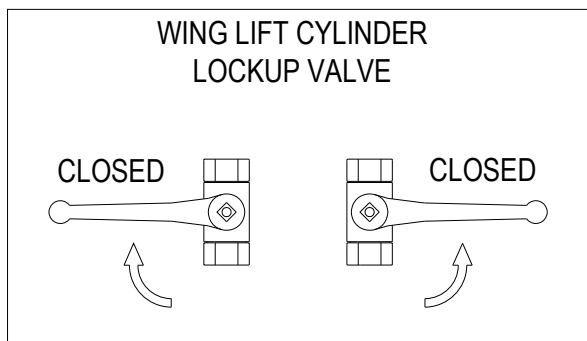

10. Tire maintenance and safety:

A - Keep the pressure equal on all wheels. See specifications for correct tire pressure.

B - Do not inflate tires above recommended pressure.

C - Only experienced personal should attempt to repair a tire or mount tire on a wheel.

D - Do not weld or heat tire and wheel assembly when tire is inflated. The heat may cause an increase in tire pressure causing tire to explode.

E - Periodically check tires for cuts, bulges and damaged rims.



CAUTION

When inflating tires use a clip on chuck and hose extension which will allow operator to stand clear of tire and wheel assembly. Do not stand in front of or over the tire when inflating. Exploding tire and wheel parts can cause serious injury or death.

Troubleshooting

Problem	Possible Cause	Remedy
Outside blades of front wings are cutting too deep causing disc to ridge at outside.	Wheels raised off ground causing front disc to drop.	Lower wheels to ground so the gauge discing depth.
	Tire pressure is low on outer wheels causing disc to cut deep at outside.	Inflate tire, see tire pressures.
	Disc is lower at front than at rear.	Using levelling crank raise front of disc - See FIG. 10.
	Wing wheel not adjusted for proper cutting depth.	Raise outside of wing by adjusting lift cylinder I-bolt.
	Wing rockshaft cylinders are not synchronized with centre from rockshaft cylinders.	Rephase rockshaft cylinders.
Outside blades of front wings are not cutting deep enough.	Disc is higher at front than rear	Using levelling crank raise front of disc.
Outside blades on front and rear gangs are cutting too deep.	Tire pressure is low for wing wheels causing wings to cut deeper.	Check tire inflation for all wheels, see tire pressure.
	Outside of wing frame is lower than main frame.	Raise outside of wing with wing rockshaft cylinder anchor bolt.
	Wing rockshaft cylinders are not synchronized with centre from rockshaft cylinders.	Rephase rockshaft cylinder.
Outside blades on front and rear gangs are not cutting deep enough.	Tire pressure is lower on centre section wheels than wing section wheel causing centre section to cut deeper	Check tire inflation for all wheels, see tire pressure.
	Outside of wing frame(s) is higher than main frame.	Lower outside of wing with wing rockshaft cylinder anchor bolt.
	Wing rockshaft cylinder is not synchronized with main frame rockshaft cylinder	Rephase rockshaft cylinder
Disc is leaving a ridge at center of discing	Rear gangs are cutting deeper than front gangs.	Level disc using levelling crank - See FIG. 10.
	a high discing speed is causing disc to throw dirt further resulting in a pile at centre.	Reduce discing speed.
	Rear gangs are too close together.	Increase distance between rear gangs.

Problem	Possible Cause	Remedy
Rear gangs are not filling furrow left by front gangs at center of disc	Front gangs are cutting deeper than rear gangs	Level disc using levelling crank - See FIG. 10.
	a low discing speed is causing disc to not throw dirt far enough to fill furrow left by front centre blades.	Increase discing speed
	Rear gangs are too far apart.	Decrease distance between rear gangs.
Front gangs are leaving unbroke ground at center of disc.	Front gangs are either overlapped too much or not enough.	Adjust overlap of front gangs.
Disc gangs are plugging	Scrapers are too far from blades.	Adjust scrapers so they are contacting blades.
	Thrash conditions too heavy for your machine cylinder(s).	Contact your dealer.
When raising disc out of ground, main frame comes out of ground while outside of wing(s) lags behind or does not come out of ground..	Piston seals on wing rockshaft cylinder(s) are damaged.	Replace piston seals of wing rockshaft cylinder.
When raising disc out of ground, main frame rockshaft cylinder is fully extended while rockshaft cylinder(s) are not fully extended.	Rockshaft cylinders are not synchronized	Rephrase rockshaft cylinders
When raising disc out of ground wing rockshaft cylinder is fully extended while main frame rockshaft cylinder(s) are not fully extended.	Rockshaft cylinders are not synchronized	Rephrase rockshaft cylinders
Disc will not penetrate soil.	Soil condition too hard for your machine	Contact your dealer.

Troubleshooting

Problem	Possible Cause	Remedy
Outside blades of front wings are cutting too deep causing disc to ridge at outside.	Wheels raised off ground causing front disc to drop.	Lower wheels to ground so the gauge discing depth.
	Tire pressure is low on outer wheels causing disc to cut deep at outside.	Inflate tire, see tire pressures.
	Disc is lower at front than at rear.	Using levelling crank raise front of disc - See FIG. 10.
	Wing wheel not adjusted for proper cutting depth.	Raise outside of wing by adjusting lift cylinder I-bolt.
	Wing rockshaft cylinders are not synchronized with centre from rockshaft cylinders.	Rephase rockshaft cylinders.
Outside blades of front wings are not cutting deep enough.	Disc is higher at front than rear	Using levelling crank raise front of disc.
Outside blades on front and rear gangs are cutting too deep.	Tire pressure is low for wing wheels causing wings to cut deeper.	Check tire inflation for all wheels, see tire pressure.
	Outside of wing frame is lower than main frame.	Raise outside of wing with wing rockshaft cylinder anchor bolt.
	Wing rockshaft cylinders are not synchronized with centre from rockshaft cylinders.	Rephase rockshaft cylinder.
Outside blades on front and rear gangs are not cutting deep enough.	Tire pressure is lower on centre section wheels than wing section wheel causing centre section to cut deeper	Check tire inflation for all wheels, see tire pressure.
	Outside of wing frame(s) is higher than main frame.	Lower outside of wing with wing rockshaft cylinder anchor bolt.
	Wing rockshaft cylinder is not synchronized with main frame rockshaft cylinder	Rephase rockshaft cylinder
Disc is leaving a ridge at center of discing	Rear gangs are cutting deeper than front gangs.	Level disc using levelling crank - See FIG. 10.
	a high discing speed is causing disc to throw dirt further resulting in a pile at centre.	Reduce discing speed.
	Rear gangs are too close together.	Increase distance between rear gangs.

Problem	Possible Cause	Remedy
Rear gangs are not filling furrow left by front gangs at center of disc	Front gangs are cutting deeper than rear gangs	Level disc using levelling crank - See FIG. 10.
	a low discing speed is causing disc to not throw dirt far enough to fill furrow left by front centre blades.	Increase discing speed
	Rear gangs are too far apart.	Decrease distance between rear gangs.
Front gangs are leaving unbroke ground at center of disc.	Front gangs are either overlapped too much or not enough.	Adjust overlap of front gangs.
Disc gangs are plugging	Scrapers are too far from blades.	Adjust scrapers so they are contacting blades.
	Thrash conditions too heavy for your machine cylinder(s).	Contact your dealer.
When raising disc out of ground, main frame comes out of ground while outside of wing(s) lags behind or does not come out of ground..	Piston seals on wing rockshaft cylinder(s) are damaged.	Replace piston seals of wing rockshaft cylinder.
When raising disc out of ground, main frame rockshaft cylinder is fully extended while rockshaft cylinder(s) are not fully extended.	Rockshaft cylinders are not synchronized	Rephrase rockshaft cylinders
When raising disc out of ground wing rockshaft cylinder is fully extended while main frame rockshaft cylinder(s) are not fully extended.	Rockshaft cylinders are not synchronized	Rephrase rockshaft cylinders
Disc will not penetrate soil.	Soil condition too hard for your machine	Contact your dealer.

Frame and Gang Beam Assembly

need drawing here

Item	Part #	Description	Qty
1	DF13018	L.H. Main Frame Half Less Rockshaft Bearing Cap & Spring Cushion Assembly	1
2	DF13019	R.H. Main Frame Half Less Rockshaft Bearing Caps	1
3	DF13020	L.H. Wide Wing Frame - 85" (2159mm) Overall Width Less Cylinder Lug I-bolt, & Wing Lift Cylinder Pins	1
	DF13021	L.H. Narrow Wing Frame - 42-1/2" (1080mm) Overall Width Less Cylinder Lug I-bolt & Wing Lift Cylinder Pins	1
	DF13139	L.H. Super Narrow Wing Frame - 29-1/4" (742mm) Overall Width Less Cylinder Lug I-bolt & Wing Lift Cylinder Pins	1
4	DF13022	R.H. Wide Wing Frame - 85" (2159mm) Overall Width Less Cylinder Lug I-bolt & Wing Lift Cylinder Pins	1
	DF13023	R.H. Narrow Wing Frame - 42-1/2" (1080mm) Overall Width Less Cylinder Lug I-bolt & Wing Lift Cylinder Pins	1
	DF13138	R.H. Super Narrow Wing Frame - 29-1/4" (742mm) Overall Width Less Cylinder Lug I-bolt & Wing Lift Cylinder Pins	1
5	DG13024	L.H. Front Main Frame Gang Beam - 86-1/2" (2197mm) Long	1
6	DG13025	R.H. Front Main Frame Gang Beam - 86-1/2" (2197mm) Long	1
7	DG13026	L.H. Rear Main Frame Gang Beam - 69-1/2" (1765mm) Long	1
8	DG13027	R.H. Rear Main Frame Gang Beam - 69-1/2" (1765mm) Long	1

9" (230mm) Spacing			
9	DG13142	L.H. Front Wing Gang Beam (Solid Type) - 62" (1574mm) Long	*
	DG13143	L.H. Front Wing Gang Beam (Solid Type) - 70" (1778mm) Long	*
	DG13028	L.H. Front Wing Gang Beam (Solid Type) - 79" (2007mm) Long	*
	DG13029	L.H. Front Wing Gang Beam (Solid Type) - 107" (2718mm) Long	*
	DG13036	L.H. Front Wing Gang Beam (Solid Type) - 128" (3251mm) Long	*
	DG13031	L.H. Front Wing Gang Beam (Solid Type) - 145" (3683mm) Long	*
	DG13043	L.H. Front Wing Gang Beam (Solid Type) - 154" (3912mm) Long	*
	DG13170	L.H. Front Wing Gang Beam (Solid Type) - 163" (4140mm) Long	*

10-1/2" (230mm) Spacing			
	DG13144	L.H. Front Wing Gang Beam (Solid Type) - 64" (1626mm) Long	*
	DG13146	L.H. Front Wing Gang Beam (Solid Type) - 72" (1828mm) Long	*
	DG13034	L.H. Front Wing Gang Beam (Solid Type) - 85" (2159mm) Long	*
	DG13029	L.H. Front Wing Gang Beam (Solid Type) - 107" (2718mm) Long	*
	DG13036	L.H. Front Wing Gang Beam (Solid Type) - 128" (3251mm) Long	*
	DG13037	L.H. Front Wing Gang Beam (Solid Type) - 150" (3810mm) Long	*
	DG13038	L.H. Front Wing Gang Beam (Solid Type) - 161" (4089mm) Long	*
	DG13170	L.H. Front Wing Gang Beam (Solid Type) - 168" (4267mm) Long	*

Item	Part #	Description	Qty
------	--------	-------------	-----

12" (305mm) Spacing			
	DG13147	L.H. Front Wing Gang Beam (Solid Type) - 62" (1574mm) long	*
	DG13148	L.H. Front Wing Gang Beam (Solid Type) - 72" (1828mm) long	*
	DG13028	L.H. Front Wing Gang Beam (Solid Type) - 79" (2007mm) long	*
	DG13149	L.H. Front Wing Gang Beam (Solid Type) - 92" (2337mm) long	*
	DG13040	L.H. Front Wing Gang Beam (Solid Type) - 104" (2542mm) long	*
	DG13041	L.H. Front Wing Gang Beam (Solid Type) - 129" (3277mm) long	*
	DG13042	L.H. Front Wing Gang Beam (Solid Type) - 142" (3607mm) long	*
	DG13043	L.H. Front Wing Gang Beam (Solid Type) - 155" (3937mm) long	*
	DG13044	L.H. Front Wing Gang Beam (Solid Type) - 166" (4216mm) long	*

9" (230mm) Spacing			
10	DG13160	R.H. Front Wing Gang Beam (Solid Type) - 62" (1574mm) Long	*
	DG13161	R.H. Front Wing Gang Beam (Solid Type) - 70" (1778mm) Long	*
	DG13045	R.H. Front Wing Gang Beam (Solid Type) - 79" (2007mm) Long	*
	DG13046	R.H. Front Wing Gang Beam (Solid Type) - 107" (2718mm) Long	*
	DG13047	R.H. Front Wing Gang Beam (Solid Type) - 128" (3251mm) Long	*
	DG13048	R.H. Front Wing Gang Beam (Solid Type) - 145" (3683mm) Long	*
	DG13049	R.H. Front Wing Gang Beam (Solid Type) - 154" (3912mm) Long	*
	DG13171	R.H. Front Wing Gang Beam (Solid Type) - 163" (4140mm) Long	*

10-1/2" (230mm) Spacing			
	DG13165	R.H. Front Wing Gang Beam (Solid Type) - 64" (1626mm) Long	*
	DG13166	R.H. Front Wing Gang Beam (Solid Type) - 72" (1828mm) Long	*
	DG13051	R.H. Front Wing Gang Beam (Solid Type) - 85" (2159mm) Long	*
	DG13046	R.H. Front Wing Gang Beam (Solid Type) - 107" (2718mm) Long	*
	DG13052	R.H. Front Wing Gang Beam (Solid Type) - 128" (3251mm) Long	*
	DG13053	R.H. Front Wing Gang Beam (Solid Type) - 150" (3810mm) Long	*
	DG13054	R.H. Front Wing Gang Beam (Solid Type) - 161" (4089mm) Long	*
	DG13171	R.H. Front Wing Gang Beam (Solid Type) - 168" (4267mm) Long	*

Item	Part #	Description	Qty
------	--------	-------------	-----

12" (230mm) Spacing			
	DG13167	R.H. Front Wing Gang Beam (Solid Type) - 62" (1574mm) long	*
	DG13168	R.H. Front Wing Gang Beam (Solid Type) - 72" (1828mm) long	*
	DG13045	R.H. Front Wing Gang Beam (Solid Type) - 79" (2007mm) long	*
	DG13169	R.H. Front Wing Gang Beam (Solid Type) - 92" (2337mm) long	*
	DG13055	R.H. Front Wing Gang Beam (Solid Type) - 104" (2642mm) long	*
	DG13056	R.H. Front Wing Gang Beam (Solid Type) - 129" (3277mm) long	*
	DG13057	R.H. Front Wing Gang Beam (Solid Type) - 142" (3607mm) long	*
	DG13058	R.H. Front Wing Gang Beam (Solid Type) - 155" (3937mm) long	*
	DG13059	R.H. Front Wing Gang Beam (Solid Type) - 166" (4216mm) long	*

9" (230mm) Spacing			
11	DG13176	L.H. Rear Wing Gang Beam (Solid Type) - 89" (2260mm) Long	*
	DG13177	L.H. Rear Wing Gang Beam (Solid Type) - 97" (2463mm) Long	*
	DG13060	L.H. Rear Wing Gang Beam (Solid Type) - 107" (2718mm) Long	*
	DG13061	L.H. Rear Wing Gang Beam (Solid Type) - 135" (3429mm) Long	*
	DG13062	L.H. Rear Wing Gang Beam (Solid Type) - 153" (3886mm) Long	*
	DG13063	L.H. Rear Wing Gang Beam (Solid Type) - 173" (4394mm) Long	*
	DG13064	L.H. Rear Wing Gang Beam (Solid Type) - 181" (4597mm) Long	*
	DG13172	L.H. Rear Wing Gang Beam (Solid Type) - 188" (4775mm) Long	*

10-1/2" (230mm) Spacing			
	DG13178	L.H. Rear Wing Gang Beam (Solid Type) - 90" (2286mm) Long	*
	DG13179	L.H. Rear Wing Gang Beam (Solid Type) - 100" (2540mm) Long	*
	DG13066	L.H. Rear Wing Gang Beam (Solid Type) - 113" (2870mm) Long	*
	DG13061	L.H. Rear Wing Gang Beam (Solid Type) - 135" (3429mm) Long	*
	DG13067	L.H. Rear Wing Gang Beam (Solid Type) - 156" (3962mm) Long	*
	DG13068	L.H. Rear Wing Gang Beam (Solid Type) - 178" (4521mm) Long	*
	DG13069	L.H. Rear Wing Gang Beam (Solid Type) - 189" (4801mm) Long	*
	DG13173	L.H. Rear Wing Gang Beam (Solid Type) - 197" (5004mm) Long	*

Item	Part #	Description	Qty
------	--------	-------------	-----

12" (305mm) Spacing			
	DG13181	L.H. Rear Wing Gang Beam (Solid Type) - 85" (2159mm) Long	*
	DG13182	L.H. Rear Wing Gang Beam (Solid Type) - 97" (2464mm) Long	*
	DG13071	L.H. Rear Wing Gang Beam (Solid Type) - 110" (2794mm) Long	*
	DG13183	L.H. Rear Wing Gang Beam (Solid Type) - 123" (3124mm) Long	*
	DG13061	L.H. Rear Wing Gang Beam (Solid Type) - 135" (3429mm) Long	*
	DG13072	L.H. Rear Wing Gang Beam (Solid Type) - 160" (4064mm) Long	*
	DG13063	L.H. Rear Wing Gang Beam (Solid Type) - 173" (4394mm) Long	*
	DG13073	L.H. Rear Wing Gang Beam (Solid Type) - 186" (4724mm) Long	*
	DG13074	L.H. Rear Wing Gang Beam (Solid Type) - 195" (4953mm) Long	*

9" (230mm) Spacing			
12	DG13187	R.H. Rear Wing Gang Beam (Solid Type) - 89" (2260mm) Long	*
	DG13188	R.H. Rear Wing Gang Beam (Solid Type) - 97" (2463mm) Long	*
	DG13075	R.H. Rear Wing Gang Beam (Solid Type) - 107" (2718mm) Long	*
	DG13076	R.H. Rear Wing Gang Beam (Solid Type) - 135" (3429mm) Long	*
	DG13077	R.H. Rear Wing Gang Beam (Solid Type) - 153" (3886mm) Long	*
	DG13078	R.H. Rear Wing Gang Beam (Solid Type) - 173" (4394mm) Long	*
	DG13079	R.H. Rear Wing Gang Beam (Solid Type) - 181" (4597mm) Long	*
	DG13174	R.H. Rear Wing Gang Beam (Solid Type) - 188" (4775mm) Long	*

10-1/2" (230mm) Spacing			
	DG13189	R.H. Rear Wing Gang Beam (Solid Type) - 90" (2286mm) Long	*
	DG13192	R.H. Rear Wing Gang Beam (Solid Type) - 100" (2540mm) Long	*
	DG13080	R.H. Rear Wing Gang Beam (Solid Type) - 113" (2870mm) Long	*
	DG13076	R.H. Rear Wing Gang Beam (Solid Type) - 135" (3429mm) Long	*
	DG13081	R.H. Rear Wing Gang Beam (Solid Type) - 156" (3962mm) Long	*
	DG13082	R.H. Rear Wing Gang Beam (Solid Type) - 178" (4521mm) Long	*
	DG13083	R.H. Rear Wing Gang Beam (Solid Type) - 189" (4801mm) Long	*
	DG13175	R.H. Rear Wing Gang Beam (Solid Type) - 197" (5004mm) Long	*

Item	Part #	Description	Qty
12" (305mm) Spacing			
	DG13193	R.H. Rear Wing Gang Beam (Solid Type) - 85" (2159mm) Long	*
	DG13194	R.H. Rear Wing Gang Beam (Solid Type) - 97" (2464mm) Long	*
	DG13085	R.H. Rear Wing Gang Beam (Solid Type) - 110" (2794mm) Long	*
	DG13195	R.H. Rear Wing Gang Beam (Solid Type) - 123" (3124mm) Long	*
	DG13086	R.H. Rear Wing Gang Beam (Solid Type) - 135" (3429mm) Long	*
	DG13087	R.H. Rear Wing Gang Beam (Solid Type) - 160" (4064mm) Long	*
	DG13078	R.H. Rear Wing Gang Beam (Solid Type) - 173" (4394mm) Long	*
	DG13088	R.H. Rear Wing Gang Beam (Solid Type) - 186" (4724mm) Long	*
	DG13089	R.H. Rear Wing Gang Beam (Solid Type) - 195" (4953mm) Long	*
13	DFA5041	Rockshaft Bearing Cap - Plain, Non-Reinforced Type	3
14	DR5259	Rockshaft Bearing Liner Half	6
15	DFA9564	1-1/4" (32mm) N.C. I-Bolt Cylinder Lug	2
	DW13339	1-1/4" (32mm) N.C. I-Bolt Cylinder Lug used w/ 15.0/55-17 Tires on M Frame	2
16	DC9615	11" (279mm) Long Compression Spring	1
17	DFA10536	Spring Cushion Plate	1
18	DG13009	1-1/2" (38.1mm) Dia. x 5" (127mm) (Under Head) Wing Hinge Pin	4
19	B100140	1" (25.4mm) x 14" (356mm) N.C. Hex Bolt	1
20	B125035	1-1/4" (31.7mm) x 3-1/2" (88.9mm) N.C. Hex Bolt	32
21	B100325	1" (25.4mm) x 3-1/4" (82.6mm) N.C. Hex Bolt	12
22	B075025	3/4" (19mm) x 2-1/2" (63.5mm) N.C. Hex Bolt	6
23	DH5165	1-1/2" (38.1mm) N.C. Slotted Hex Nut	4
24	BN125	1-1/4" (31.7mm) N.C. Hex Nut	36
25	BN100	1" (25.4mm) N.C. Hex Nut	14
26	BN075	3/4" (19mm) N.C. Hex Nut	6
27	BP31225	5/16" (7.8mm) x 2-1/4" (57mm) Cotter Pin	4
28	10GN1	1/4" (6.35mm) - 28 Straight Grease Fitting - Bottom	7
29	10GN2	1/4" (6.35mm) - 28 - 45° Grease Fitting - Top	3
30	BW125L	1-1/4" (31.7mm) Lockwasher	32
31	BW075L	3/4" (19mm) Lockwasher	6
32	DF5063	Rockshaft Bearing Cap Shim	*
33	DF13224	2" x 12" Shim (50.4mm x 305mm)	*

*as required

Decals (Frame and Gang Beam)

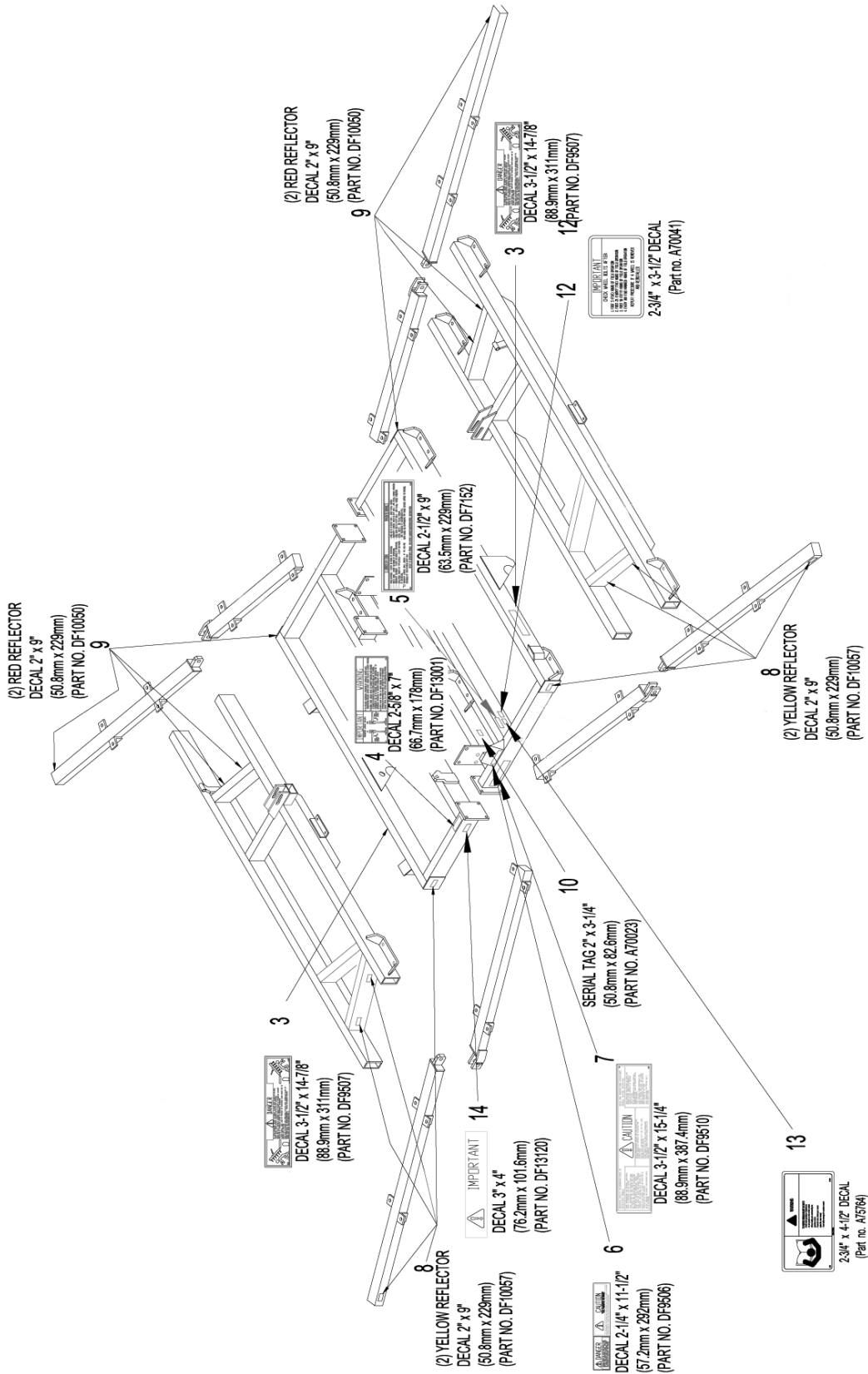

Item	Part #	Description	Qty
1	DF13119	8700 LTF Decal (3-1/4" (82.6mm) x 11" (279mm))	4
2	DF13116	Ezee-On Decal (3" x 19-5/8 (76 x 499mm))	4
3	DF9507	Danger Decal (3-1/2" (88.9mm) x 14-7/8" (311mm))	2
4	DF13001	Hydraulic Lockup Decal (2-5/8" (66.7mm) x 7" (178mm))	1
5	DF7152	Maintenance Decal (2-1/2" (63.5mm) x 9" (229mm))	1
6	DF9506	Danger, Caution Decal (2-1/4" (57.2mm) x 11-1/2" (292mm))	1
7	DF9510	Caution Decal (3-1/2" (88.9mm) x 15-1/4" (387mm))	1
8	DF10057	Yellow Reflector (2" (50.8mm) x 9" (229mm))	6
9	DF10050	Red Reflector (2" (50.8mm) x 9" (229mm))	6
10	A70023	Serial Tag (2" (50.8mm) x 3-1/4" (82.6mm))	1
11	A75764	Read Manual Decal (2-5/16" (58.6mm) x 4-1/2" (114.3mm))	1
12	A70041	Check whl bolt decal - 2-1/4" x 3-1/2" (57.2mm x 88.9mm)	1
13	A75764	Read manual decal - 2-3/4" x 4-1/2" (69.8mm x 114.3mm)	1
14	DF13120	Disc with wings up decal	1
	L001	Ezee-On Yellow Paint - 1 quart	*
	L002	Ezee-On Yellow Paint - 1/2 pint	*
	L015	Black Paint - 1 liter	*
	L016	Black Paint - 1/2 pint	*

* as required

Hitch and Leveling Crank Assembly

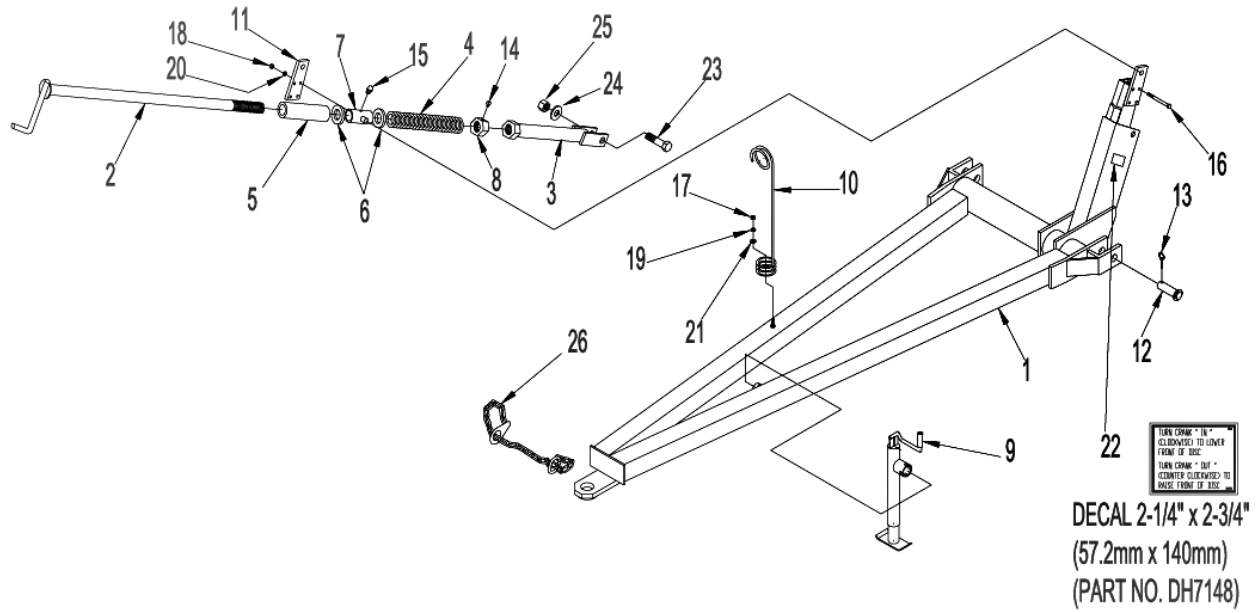

Item	Part #	Description	Qty
1	DHB13097	Hitch c/w item 11, 12, 13 & 18	1
2	DCA9970	Leveling Crank - 50" (1270mm) Long	1
3	DCA5195	Leveling Link (16-3/4" (60.4mm) Pipe Length)	1
4	DC9618	Compression Spring	1
5	DC13098	Spacer Tube -11" (279mm) Long)	1
6	DC15	Thrust Bearing -Timken #T199	2
7	DCA5184	Bearing Tube - Leveling Crank	1
8	DH5	2" (50.8mm) N.C. Heavy Hex Nut - drilled for set screw	1
9	DHB5170	Hitch Jack	1
10	DH9961	Hose Support - Spring Coil Type	1
11	DH5146	Leveling Arm Lug	1
12	DHA9605	Hitch Pin - 1-1/2" (38.1mm) Dia. x 5" (127mm)	2
13	DH12517	7/16" (10.9mm) x 1-7/16" (36.3mm) Lynch Pin	2
14	BO50010S	1/2" (12.7mm) x 1" (25.4mm) N.C. Square Head Set Screw	1
15	10GN1	1/4" (6.35mm) - 28 Straight Grease Fitting	1
16	B050050	1/2" (12.7mm) x 5" (127mm) N.C. Hex Bolt	4
17	BN062	5/8" (15.7mm) N.C. Hex Nut	1
18	BN050	1/2" (12.7mm) N.C. Hex Nut	4
19	BW062L	5/8" (15.7mm) Lockwasher	1
20	BW050L	1/2" (12.7mm) Lockwasher	4
21	BW17506806F	11/16" (17.2mm) I.D. x 1-3/4" (44.4mm) O.D. Flatwasher	1
22	DH7148	Crank Decal (2-1/4" (57.2mm) x 2-3/4" (140mm))	1
23	DR5215	1-1/4" (31.7mm) x 4-3/4" (120.6mm) N.C. Hex Bolt w/special thread length	1
24	BW125L	1-1/4" (31.7mm) Lockwasher	1
25	BN125	1-1/4" (31.7mm) N.C. Hex Nut	1
26	D13090	Safety Chain 20200 lbs up to 32 ft. (9165 Kgs for up to 9.75m)	1
	D13091	Safety Chain 30400 lbs for 35 to 42 ft. (13793 Kgs for 10.67m to 12.8m)	

Rockshaft and Wheel Assembly - w/ Main Frame Walking Beams

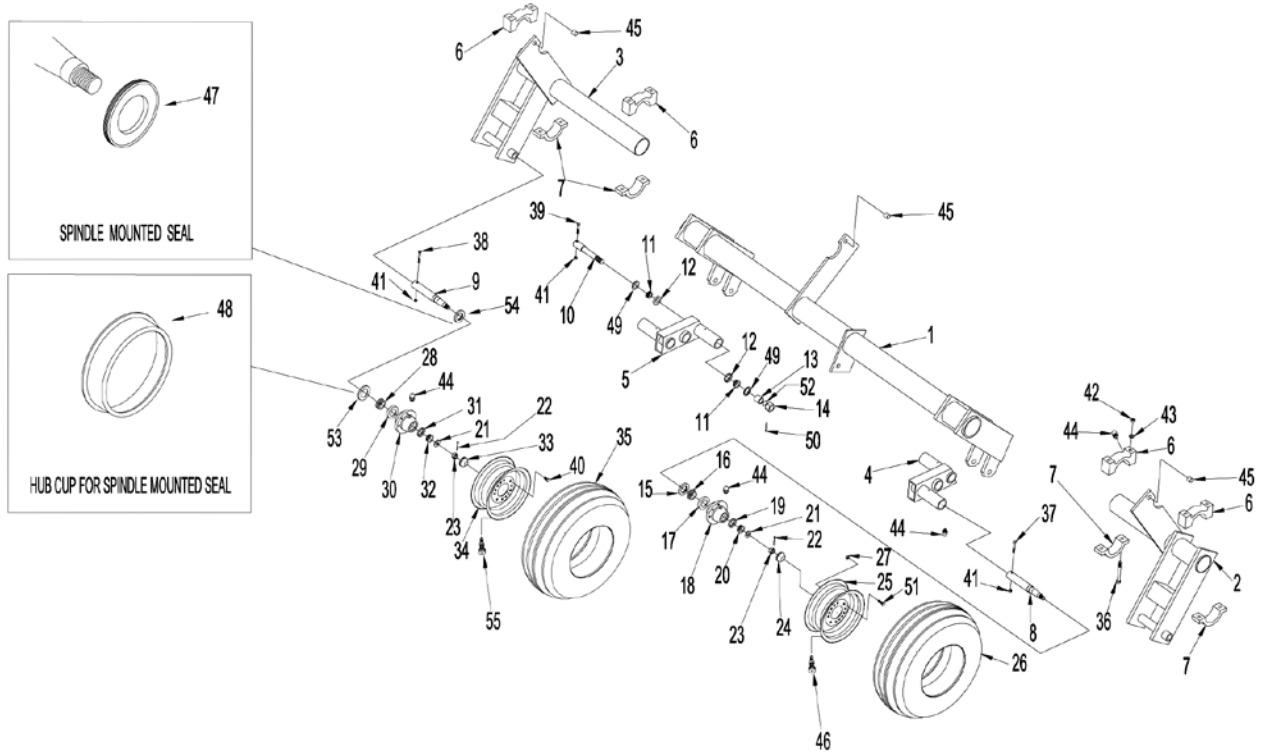

Item	Part #	Description	Qty
1	DRA13092	Main Frame Rockshaft	1
2	DRA13093	L.H. Narrow and Wide Wing Rockshaft - 41"	*
3	DRA13095	R.H. Narrow and Wide Wing Rockshaft - 41"	*
4	DRA13131	L.H. Walking Beam Main Frame	1
5	DRA13130	R.H. Walking Beam Main Frame	1
6	DR8601T	Rockshaft Bearing - Bottom Half	4
7	DR8601B	Rockshaft Bearing - Top Half	4
8	DR13004	812 Spindle - 13-3/4"(348mm)	4
9	DR7156	618 Spindle - 14-1/2" (368mm)	4
10	DR13007	Walking Beam Pivot Bolt - Main Frame	2
11	DR13124	Cone Bearing #25877	4
12	DR13125	Bearing Cup #25821	4
13	DR13008	Sleeve Pivot Pin	2
14	DR13126	1-1/4" (31.7mm) N.F. Slotted Hex Nut	2
15	DR9680	Grease Seal #SE-17	4
16	DR9684	Inner Cone Bearing #3780	4
17	DR9682	Inner Cup #3720	4
18	DRA9679	Hub c/w Cups - 8 Bolt	4
19	DR9683	Outer Cup #2720	4
20	DR9685	Outer Cone Bearing #2790	4
21	BW20010614F	2" (50.8mm) O.D. x 1-1/16" (25.5mm) I.D. x .140" (3.55mm) Flatwasher	4
22	BP18125	3/16" (4.76mm) x 1-1/4" (31.7mm) Cotter Pin	4
23	DR110	1" (25.4mm) N.F. Hex Slotted Nut	4
24	DR9681	Hub Cab	4
25	S81509	15" (381mm) x 10" (254mm) x 8 Bolt Rim	4
26	125L15FIF	12.5L x 15 "F" FITire	4
27	DR9670	9/16" (14.2mm) N.F. Hex Nut	32
28	DR120	Cone Bearing - #LM25580	4
29	DR118	Cup - #LM25520	4
30	DRA9	618 Hub c/w Cups	4
31	DR92	Cup - #LM48510	4
32	DR91	Cone Bearing - #LM48548	4
33	DR123	Hub Cap	4
34	DR5261	15" (381mm) x 8" (203mm) - 6 Bolt Rim - (requires metal valve stem)	4
35	125L15FID	12.5L x 15 "D" F1Tire	4
36	BO75065	3/4" (19mm) x 6-1/2" (165mm) N.C. Hex Bolt	4
37	BO50045	1/2" (12.7mm) x 4-1/2" (114.3mm) N.C. Hex Bolt	4
38	BO50035	1/2" (12.7mm) x 3-1/2" (88.9mm) N.C. Hex Bolt	4
39	BO50030	1/2" (12.7mm) x 3" (76.2mm) N.C. Hex Bolt	4

Item	Part #	Description	Qty
40	DR125	9/16" (14.2mm) N.F. x 1-1/8" (28.5mm) Wheel Bolt	56
41	BN050L	1/2" (12.7mm) N.C. Nylon Locknut	10
42	BN075	3/4" (19mm) N.C. Hex Nut	8
43	BW075L	3/4" (19mm) Lockwasher	8
44	10GN1	1/4" (6.35mm) - 28 Straight Grease Fitting	18
45	10GN3	Grease Fitting - Press in Type	*
46	DR13120	1-1/4" (31.8mm) I.D. x 1-1/4" (31.8mm) Long Steel Insert	3
47	C60154	Valve Stem - Metal	8
48	DR13190	Seal - Spindle Mount Type	4
49	DR13190	Seal Cup - Spindle Mount Type Seal	4
50	DR13121	Seal - P/N 18823	4
51	BP31200	5/16" (7.8mm) x 2" (50.8mm) Cotter Pin	4
52	DR9671	9/16" (14.2mm) N.F. x 1-11/16" (42.7mm) Wheel Bolt	32
	DR13134	1-3/8" I.D. (35mm) x 14 GA Machinery Bushing	*

* as required

Rockshaft and Wheel Assembly (Off Highway Option)

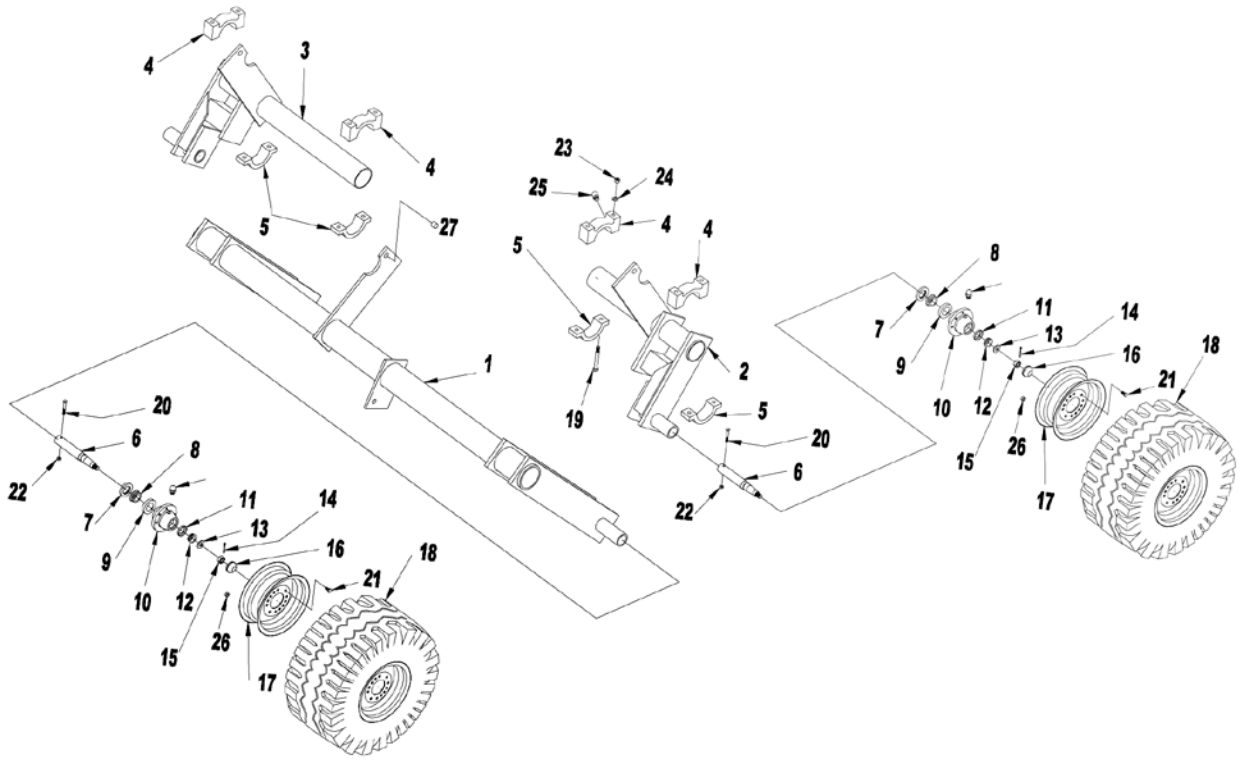

Item	Part #	Description	Qty
1	DRA13107	Main Frame Rockshaft (Australia Only)	1
2	DRA13108	L.H. Narrow Wing Assembly (Australia Only)	*
	DRA13109	L.H. Wide Wing Assembly (Australia Only)	*
3	DRA13110	R.H. Narrow Wing Assembly (Australia Only)	*
	DRA13111	R.H. Wide Wing Assembly (Australia Only)	*
4	DR8601T	Rockshaft Bearing - Bottom Half	4
5	DR8601B	Rockshaft Bearing - Top Half	4
6	A75881	812 Spindle - 18"	6
7	DR9680	Grease Seal #SE-17	6
8	DR9684	Inner Cone Bearing #3780	6
9	DR9682	Inner Cup #3720	6
10	DRA9679	Hub c/w Cups - 8 Bolt	6
11	DR9683	Outer Cup #2720	6
12	DR9685	Outer Cone Bearing #2790	6
13	BW20010318F	2" O.D. x 1-1/32" I.D. x 3/16" (50.8 x 26 x 4.6mm) Flatwasher	6
14	BP18125	3/16" x 1-1/4" (4.6mm x 31.7mm) Cotter Pin	6
15	DR110	1" (25.4mm) N.F. Hex Slotted Nut	6
16	DR9681	Hub Cab	6
17	DR9668	14.00 x 19.5 - 8 Bolt Wheel	6
18	4019195G	40 x 19 x 19.5 Off/Highway Tire	6
19	BO75065	3/4" x 6-1/2" N.C. (19.0mm x 165.1mm) Hex Bolt Gr.5	8
20	BO50040	1/2" x 4" N.C. (12.7mm x 101.6mm) Hex Bolt	6
21	DR9671	9/16" N.F. x 1-11/16" (14.2mm x 42.7mm) Wheel Bolt	48
22	BN050L	1/2" N.C. (12.7mm) Nylon Locknut	6
23	BN075	3/4" N.C. (19.0mm) Hex Nut	8
24	BN075L	3/4" (19.0mm) Lockwasher	8
25	10GN1	1/4" (6.35mm) - 28 Straight Grease Fitting	8
26	DR9670	9/16" N.F. (14.2mm) Wheel Nut	48
27	DR13120	1-1/4" I.D. x 1-1/4" Long (31.7mm x 31.7mm) Steel Insert	*

* as required

Hydraulic Assembly - Narrow and Super Narrow Wing

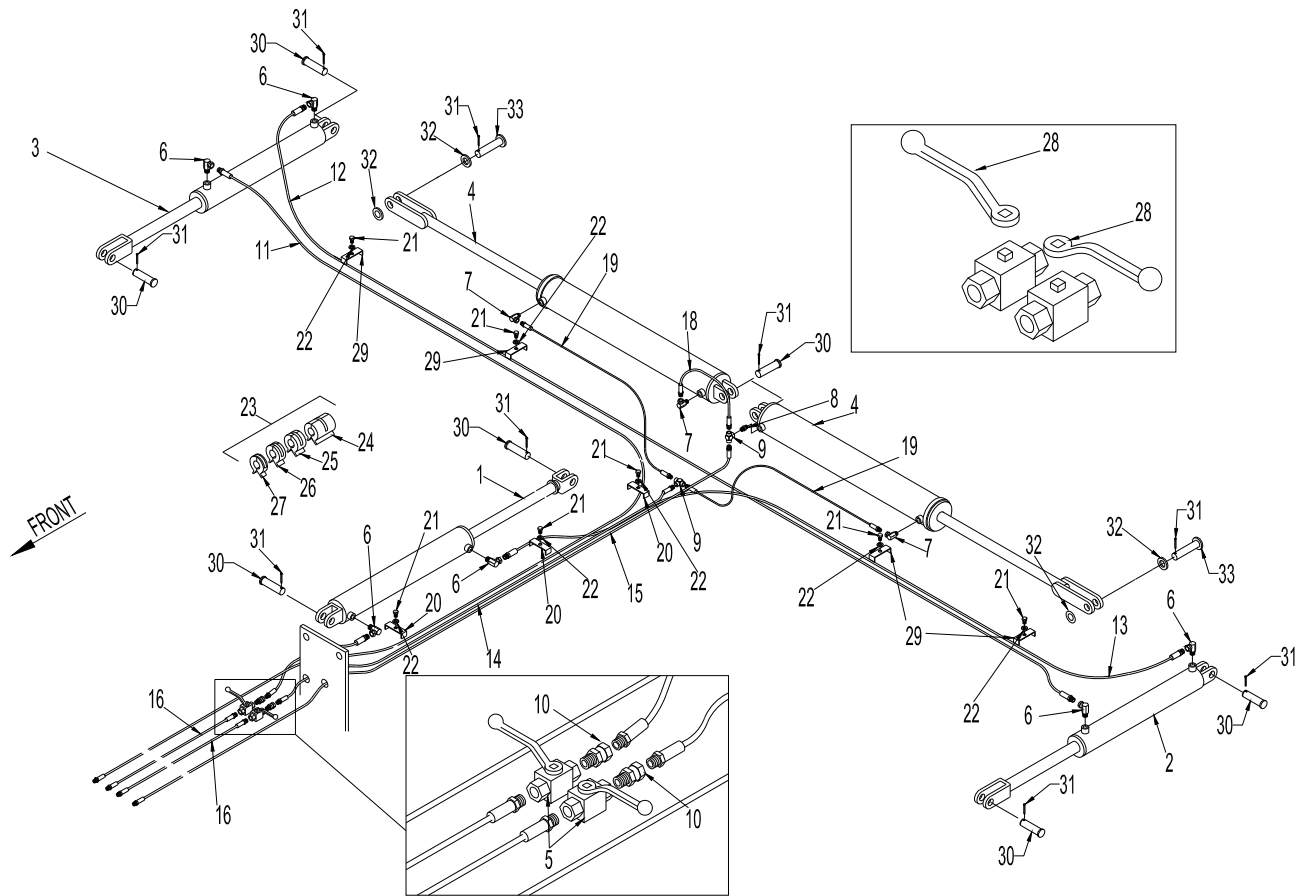

Item	Part #	Description	Qty
1	306	4" x 24" (101.6mm x 610mm) Hydraulic Cylinder	1
2	305	3-1/2" x 24" (88.9mm x 610mm) Hydraulic Cylinder	1
3	304	3" x 24" (76.2mm x 610mm) Hydraulic Cylinder	1
4	248	4" x 36" (101.6mm x 914mm) Wing Lift Cylinder - (used on models 24' to 26-1/2')	2
	242	5" x 36" (127mm x 914mm) Wing Lift Cylinder - (used on 28' models and up)	2
5	DL13099	Hydraulic Lockout Valve	2
6	DL9775	1/2" (12.7mm) x 90° Swivel Street Elbow	6
7	DL9769	3/8" (9.39mm) x 90° Swivel Street Elbow	3
8	S82371	3/8" (9.39mm) Male-Male Union	1
9	DL9767	3/8" x 3/8" x 3/8" (9.39mm x 9.39mm x 9.39mm) Swivel Tee	2
10	L1619	3/8" (9.39mm) Male-Female Swivel	2
11	D4330	3/8" x 418" (9.39mm x 10617mm) Hydraulic Hose c/w 1/2" (12.7mm) Ends for Narrow Wings)	1
	D4499	3/8" x 401"b (9.39 x 10185mm) hydraulic hose c/w 1/2" (12.7mm) ends (for super narrow wings)	1
12	D4331	3/8" x 288" (9.39mm x 7315mm) Hydraulic Hose c/w 1/2" (12.7mm) Ends - (for narrow wings)	1
	D4500	3/8" x 254" (9.39 x 6452mm) Hydraulic Hose c/w 1/2" (12.7mm) Ends (for super narrow wings)	1
13	P4332	3/8" x 207" (9.39mm x 5258mm) Hydraulic Hose c/w 1/2" (12.7mm) Ends - (for narrow wings)	1
	D4501	3/8" x 190" (9.39 x 4826mm) Hydraulic Hose c/w 1/2" (12.7mm) Ends (for super narrow wings)	1
14	D4333	3/8" x 100" (9.39mm x 2540mm) Hydraulic Hose c/w 1/2" (12.7mm) Ends	1
15	D4334	3/8" x 287" (9.39mm x 7290mm) Hydraulic Hose c/w 1/2" (12.7mm) Ends	1
16	D4335	3/8" x 172" (9.39mm x 4369mm) Hydraulic Hose c/w 1/2" and 3/8" (12.7mm and 9.39mm) Ends	2
17	D4336	3/8" x 24" (9.39mm x 610mm) Hydraulic Hose c/w 3/8" (9.39mm) End & 1/2" End	1
18	L2939	3/8" x 24" (9.39mm x 610mm) Hydraulic Hose c/w 3/8" (9.39mm) Ends	1
19	P3027	1/4" x 54" (6.35mm x 1372mm) Hydraulic Hose c/w 3/8" (9.39mm) Ends	2
20	DL13186	4 Line Hose Clamp	3
21	BO50075	1/2" x 3/4" (12.7mm x 19mm) N.C. Hex Bolt (Plated)	7
22	BW050L	1/2" (12.7mm) Lockwasher (Plated)	7
23	C50716	Wadler Universal Stroke Control Segments (8-3/4" (222mm) package)	2
24	C50717	4-1/4" (108mm) Depth Stop	2
25	C50714	2" (50.8mm) Depth Stop	2

Item	Part #	Description	Qty
26	C50712	1-1/2" (38.1mm) Depth Stop	2
27	C50711	1" (25.4mm) Depth Stop	2
28	DL13122	Handle Only - Hyd. Valve Lockout Valve - HBVH040608	2
29	DL9766	2 Line Hose Clamp - 1/2" (12.7mm) Hose	4
30	DR5262	1-1/4" Dia. x 4-3/16" (31.7mm x 106.4mm) Clevis Pin	8
31	BP31175	5/16" x 2" (7.87mm x 50.8mm) Cotter Pin	10
32	DF5068	2" O.D. x 1-5/16" I.D. x 1/4" (50.8mm x 33.3mm x 6.35mm) Flatwasher	4
33	S81856	1-1/4" Dia. x 5-13/16" (31.7mm x 147.6mm) Long (under head to centre of hole) Cylinder Pin	2

Hydraulic Assembly - Wide Wing

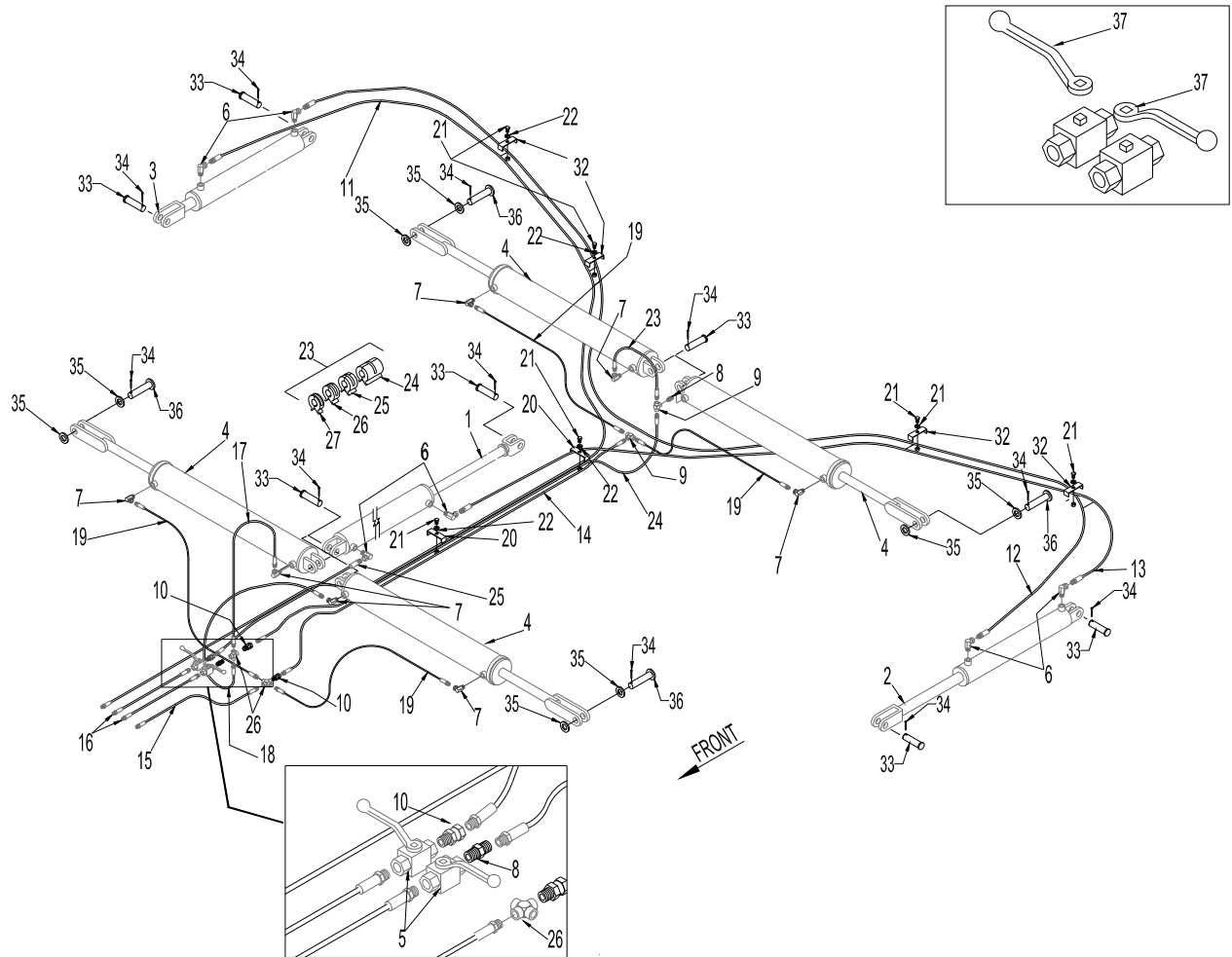

Item	Part #	Description	Qty
1	306	4" x 24" (101 x 610mm) Hydraulic Cylinder	1
2	305	3-1/2" x 24" (89 x 610mm) Hydraulic Cylinder	1
3	304	3" x 24" (76 x 610mm) Hydraulic Cylinder	1
4	242	5" x 36" (127 x 914mm) Wing Lift Cylinder	4
5	DL13099	Hydraulic Lockout Valve	2
6	DL9775	1/2" (12.7mm) x 90° Swivel Street Elbow	6
7	DL9769	3/8" (9.39mm) x 90° Swivel Street Elbow	7
8	S82371	3/8" (9.39mm) Male-Male Union	2
9	DL9767	3/8" x 3/8" x 3/8" (9.39 x 9.39 x 9.39mm) Swivel Tee	2
10	L1619	3/8" (9.39mm) Male-Female Swivel	3
11	D4338	3/8" x 489" (9.39 x 12421mm) Hydraulic Hose c/w 1/2" (12.7mm) Ends	1
12	D4339	3/8" x 402" (9.39 x 10211mm) Hydraulic Hose c/w 1/2" (12.7mm) Ends	1
13	D4340	3/8" x 253" (9.39 x 6426mm) Hydraulic Hose c/w 1/2" (12.7mm) Ends	1
14	D4333	3/8" x 100" (9.39 x 2540mm) Hydraulic Hose c/w 1/2" (12.7mm) Ends	1
15	D4341	3/8" x 178" (9.39 x 4521mm) Hydraulic Hose c/w 1/2" and 3/8" (12.7 and 9.39mm) Ends	1
16	D4335	3/8" x 172" (9.39 x 43691mm) Hydraulic Hose c/w 1/2" and 3/8" (12.7 and 9.39mm) Ends	2
17	D4342	3/8" x 20" (9.39 x 50821mm) Hydraulic Hose c/w 1/2" and 3/8" (12.7 and 9.39mm) Ends	1
18	L2937	3/8" x 30" (9.39 x 762mm) Hydraulic Hose c/w 3/8" (9.39mm) Ends	4
19	D3027	1/4" x 54" (6.35 x 1372mm) Hydraulic Hose w/ 3/8" (9.39mm) Ends	1
20	DL13186	4 Line Hose Clamp	2
21	BO50075	1/2" x 3/4" (12.7 x 19mm) N.C. Hex Bolt (Plated)	6
22	BW050L	1/2" (12.7mm) Lockwasher (Plated)	6
23	L2939	3/8" x 24" (9.39 x 610mm) Hydraulic Hose c/w 3/8" (9.39mm) Ends	1
24	D4344	3/8" x 110" (9.39 x 2794mm) Hydraulic Hose c/w 3/8" (9.39mm) Ends	1
25	D4336	3/8" x 24" (9.39 x 610mm) Hydraulic Hose c/w 3/8" (9.39mm) Ends	1
26	DL9761	3/8" (9.39mm) Steel Cross	2
27	DR13127	Wadler Universal Stroke Control Segments - 8-3/4" (222mm) package	2
28	C50717	4-1/4" (108mm) Depth Stop	2
29	C50714	2" (50.8mm) Depth Stop	2
30	C50712	1-1/2" (38.1mm) Depth Stop	2
31	C50711	1" (25.4mm) Depth Stop	2

Item	Part #	Description	Qty
32	DL9766	2" Line Hose Clamp	4
33	DR5262	1-1/4" Dia. x 4-3/16" (31.7 x 106.4mm) Clevis Pin	10
34	BP31175	5/16" x 2" (7.87 x 50.8mm) Cotter Pin	14
35	DF5068	2" O.D. x 1-5/16" I.D. x 1/4" (50.8 x 33.3 x 6.35mm)	8
36	S81856	1-1/4" Dia. x 5-13/16" (31.7 x 147.6mm) Long - Under Head to Centre of Hole - Cylinder Pin	4
37	DL13122	Handle Only - Hyd. Lock Out Valve - HBVH040608	2

Disc Gang (w/ Standard Hangers for T2-215 Bearings)
9" & 10-1/2" & 12" (230 & 267 & 305mm) Spacing

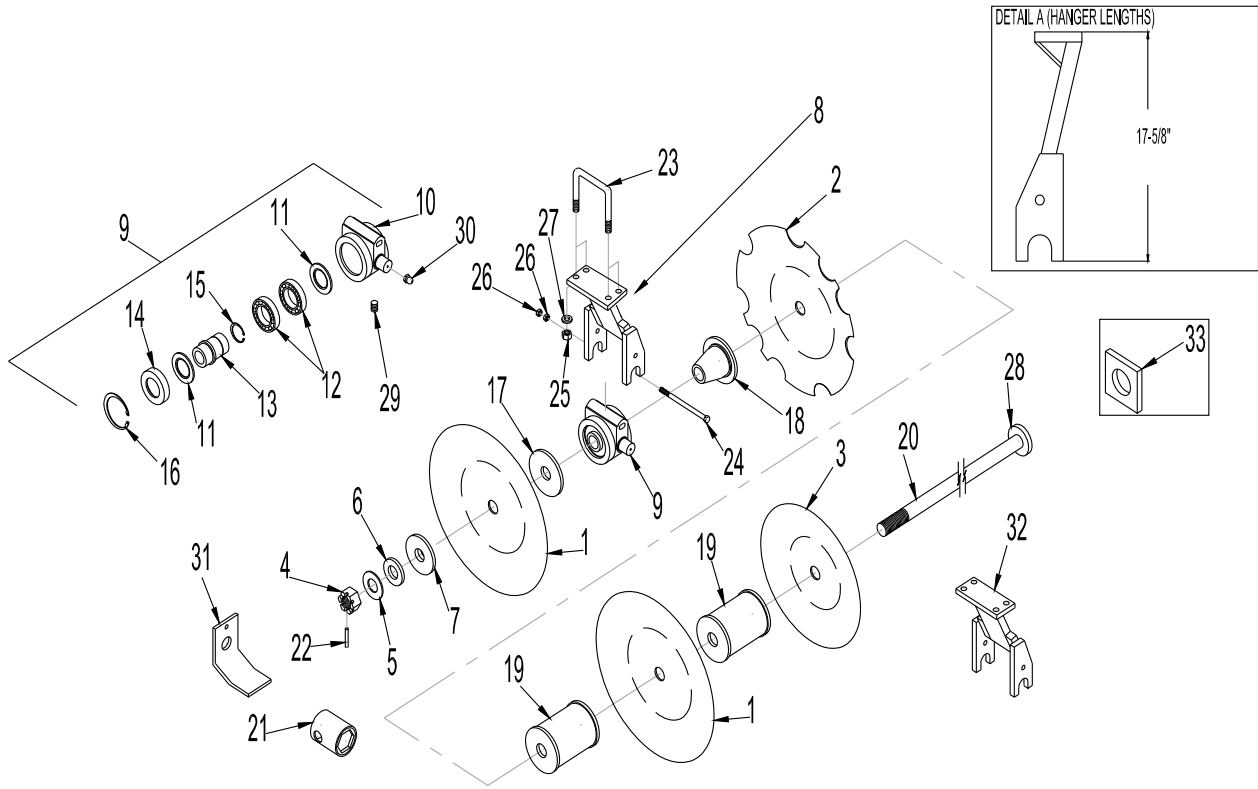

Item	Part #	Description	Qty
1	DG76	24" x 9/32" (610 x 7mm) Plain Blade	*
	DG137	24" x 5/16" (610 x 8mm) Plain Blade	*
	DG74	26" x 5/16" (660 x 8mm) Plain Blade	*
	DG107	26" x 3/8" (660 x 9mm) Plain Blade	*
	DG157	26" x 5/16" (660 x 8mm) Plain Cone Blade	*
	DG130	28" x 9/32" (711 x 9mm) Plain Blade	*
	DG180	30" x 3/8" (762 x 9mm) Plain Blade	*
2	DG138	24" x 5/16" (610 x 8mm) Notched Blade	*
	DG75	26" x 5/16" (660 x 8mm) Notched Blade	*
	DG87	26" x 3/8" (660 x 9mm) Notched Blade	*
	DG159	26" x 9mm (660 x .354) Notched Cone Blade	*
	DG20051	28" x 3/8" (711 x 9mm) Notched Blade	*
	DG181	30" x 3/8" (762 x 9mm) Notched Blade	*
3	DG149	20" x 6mm (508mm x .236") Plain Outrigger Blade	*
	DG64	22" x 6mm (559mm x .236") Plain Outrigger Blade	*
	DG76	24" x 7mm (610mm x .275") Plain Outrigger Blade	*
4	DG82	2" (50.8mm) UNC Heavy Hex Slotted Nut	*
5	DG89	1/4" (6.35mm) Shim Washer	*
6	DG88	1/2" (12.7mm) Shim Washer	*
7	DG78	5-1/2" (138mm) O.D. x 2" (50.8mm) I.D. Head Washer	*
	DG13185	5-1/2" (138mm) O.D. x 2" (50.8mm) I.D. x 3/4" (19.0mm) Head Washer - (used w/24" blades)	*
	DG13184	6" (152mm) O.D. x 2" (50.8mm) I.D. x 1" (25.4mm) Head Washer - (used w/26" & 28" blades)	*
8	DGA13162	Std. Trunion Mounted Bearing Hanger - (See Detail A above for length) - (w/o scraper tail)	*
9	DGB9900	Housing c/w Bearings, Seals, Sleeve, Snap Rings, & Cap (T2-215 Series)	*
10	DG9901	Housing Only (T2-215 Series)	*
11	DG9905	Bearing Seal (National #200322)	*
12	DG9904	#6215 Ball Bearing (Modified)	*
13	DG9906	5" (127mm) Sleeve	*
14	DG9902	Bearing Housing Cap	*
15	DG9911	External Snap Ring (Philip French #D1400-75)	*
16	DG9910	Internal Snap Ring (Philip French #D1300-130)	*
17	DGA10563	9" & 10-1/2" (230 & 267mm) Spacing, Short Half, 1-3/8" (34.9mm) Long (Convex Side) w/6" (152mm) Washer Spool	*
	DGA10572	12" (305mm) Spacing, Short Half, 2-7/8" (73mm) Long (Convex Side) w/ 6" (152mm) Washer Spool	*

Item	Part #	Description	Qty
18	DGA10571	9" (230mm) Spacing, Long Half, 2-11/16" (68mm) Long (Concave Side)	*
	DGA103	10-1/2" (267mm) & 12" (305mm) Spacing, Long Half, 4-3/16" (106mm) Long (Concave Side)	*
	DGA131	12" (305mm) Spacing Long Half, 5-1/4" (133mm) Long (Concave Side) †	*
19	DGA100	9" (230mm) Spacing, Full Spool w/ 6" (152mm) Dia. Washer on Both Ends, Spool	*
	DGA101	10-1/2" (267mm) Spacing, Full Spool w/ 6" (152mm) Dia. Washer on Both Ends, Spool	*
	DGA111	12" (305mm) Spacing, Full Spool w/ 6" (152mm) Dia. Washer on Both Ends, Spool	*

Gang Bolt c/w End Plate Ref. #28 - Unwelded - (for 9" (230mm) Spacing)			
20	DGA127	4 Blade Gang Bolt - 33-1/2" (1099mm) Long	*
	DGA67	7 Blade Gang Bolt - 61-3/4" (1721mm) Long	*
	DGA68	8 Blade Gang Bolt - 80" (2032mm) Long	*
	DGA69	9 Blade Gang Bolt - 92" (2337mm) Long	*
	DGA70	10 Blade Gang Bolt - 43-1/4" (1099mm) Long	*
	DGA71	11 Blade Gang Bolt - 67-3/4" (1721mm) Long	*
	DGA72	12 Blade Gang Bolt - 80" (2032mm) Long	*
	DGA74	14 Blade Gang Bolt - 92" (2337mm) Long	*
	DGA129	15 Blade Gang Bolt - 92" (2337mm) Long	*

Gang Bolt c/w End Plate Ref. #28 - Unwelded - (for 10-1/2" (267mm) Spacing)			
	DGA109	4 Blade Gang Bolt - 43-1/4" (1099mm) Long	*
	DGA76	6 Blade Gang Bolt - 67-3/4" (1721mm) Long	*
	DGA77	7 Blade Gang Bolt - 80" (2032mm) Long	*
	DGA78	8 Blade Gang Bolt - 92" (2337mm) Long	*
	DGA79	9 Blade Gang Bolt - 43-1/4" (1099mm) Long	*
	DGA80	10 Blade Gang Bolt - 67-3/4" (1721mm) Long	*
	DGA81	11 Blade Gang Bolt - 80" (2032mm) Long	*
	DGA82	12 Blade Gang Bolt - 92" (2337mm) Long	*
	DGA83	13 Blade Gang Bolt - 92" (2337mm) Long	*

Item	Part #	Description	Qty
------	--------	-------------	-----

Gang Bolt c/w End Plate Ref. #28 - Unwelded - (for 9" (230mm) Spacing)			
	DGA130	5 Blade Gang Bolt - 66-1/4" (1099mm) Long - Outboard	*
	DGA115	6 Blade Gang Bolt - 67-3/4" (1721mm) Long	*
	DGA69	7 Blade Gang Bolt - 80" (2032mm) Long	*
	DGA79	8 Blade Gang Bolt - 92" (2337mm) Long	*
	DGA118	9 Blade Gang Bolt - 104-3/4" (2661mm) Long	*
	DGA119	10 Blade Gang Bolt - 117" (2972mm) Long	*
	DGA120	11 Blade Gang Bolt - 129" (3277mm) Long	*
	DGA121	12 Blade Gang Bolt - 141-3/4" (3600mm) Long	*
	DGA122	13 Blade Gang Bolt - 153-3/4" (3905mm) Long	*

21	DGA35	Socket Wrench	*
22	DG10310	7/16" (10.9mm) x 3" (76.2mm) Lock Pin	*
23	DG5379	7/8" (22.2mm) x 6" (152mm) x 5-7/8" (149mm) Long U-Bolt (Plated)	*
24	BO62100	5/8" (15.7mm) x 10" (254mm) N.C. Hex Bolt Gr.5 (Plated)- Used on Machines Less Bearing Guard	*
	BO62110	5/8" (15.7mm) x 11" (279.4mm) N.C. Hex Bolt Gr. 5 (Plated) - Used on Machines Equipped w/ Bearing Guard	*
25	BN087	7/8" (22.2mm) N.C. Hex Nut (Plated)	*
26	BN062L	5/8" (15.7mm) N.C. Hex Nylon Lock Nut (Plated)	*
27	BW087L	7/8" (22.2mm) Lockwasher (Plated)	*
28	DGA5370	5-1/2" (139.7mm) End Plate - Weld On	*
29	DG9912	Set Screw - 1/4" (6.35mm) N.C. x 1/2" (12.7mm) Long	*
30	10GN1	1/4" (6.35mm) - 28 Straight Grease Fitting	*
31	DG10590	Bearing Guard - T2-215 Bearing	*
32	DGA13163	2" (50.8mm) Offset Trunion Mounted Bearing Hanger - (See Detail A for Length) - (w/o Scraper Tail)	*
	DGA13164	3-1/2" (88.9mm) Offset Trunion Mounted Bearing Hanger - (See Detail A above for length) - (w/o scraper tail)	*
33	DG5371	Wrench Drive Plate - 1/2" x 3-1/2" x 3-1/2" (12.7 x 88.9 x 88.9 mm)	*

* as required

† When ordering 12" (305mm) spacing 1/2 spools, measure length to determine correct spool.

**Disc Gang (w/ Standard Hangers for T2-215 Bearings)
10-1/2" & 12" (267 & 305mm) Spacing**

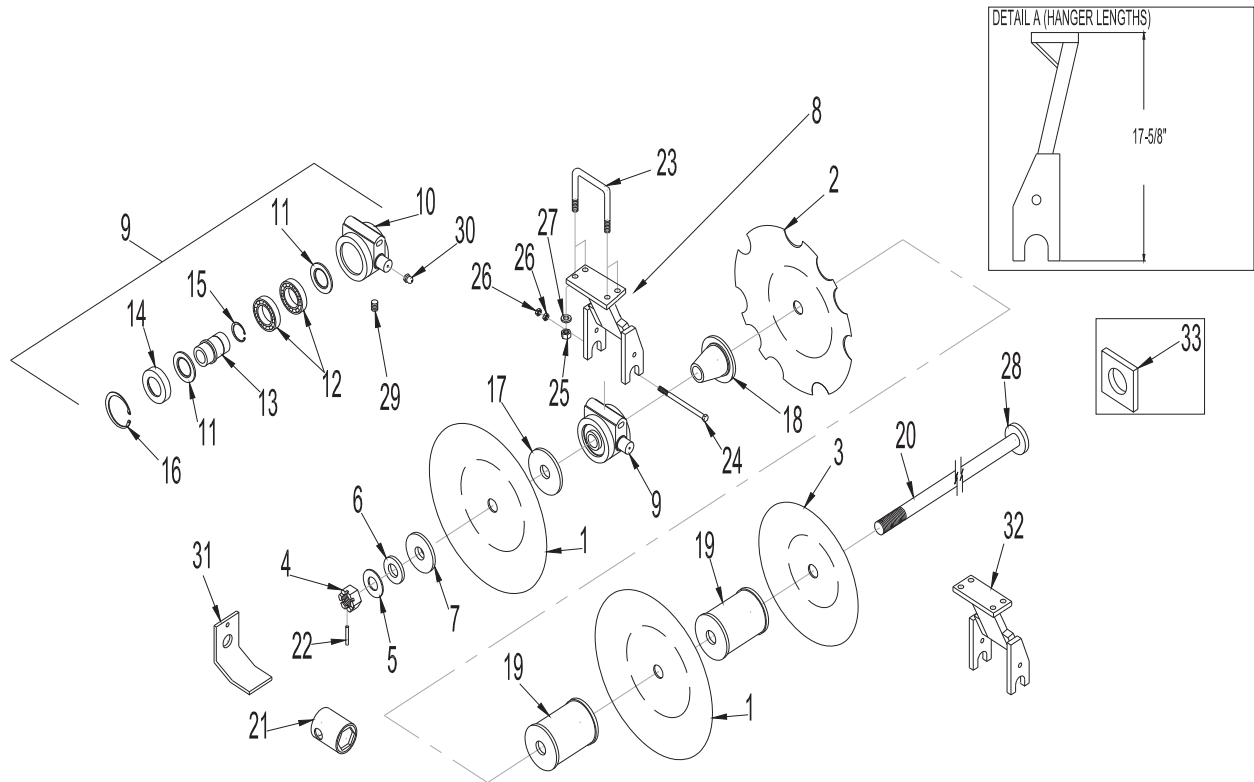

Item	Part #	Description	Qty
4	DG82	2" (50.8mm) UNC Heavy Hex Slotted Nut	*
5	DG89	1/4" (6.35mm) Shim Washer	*
6	DG88	1/2" (12.7mm) Shim Washer	*
7	DG78	5-1/2" (138mm) O.D. x 2" (50.8mm) I.D. Head Washer	*
	DG13185	5-1/2" (138mm) O.D. x 2" (50.8mm) I.D. x 3/4" (19.0mm) Head Washer - (used w/ 24" blades)	*
	DG13184	6" (152mm) O.D. x 2" (50.8mm) I.D. x 1" (25.4mm) Head Washer - (used w/26" & 28" blades)	*
8	DGA13162	Std. Trunion Mounted Bearing Hanger - (See Detail A Above for Length) - (w/o Scraper Tail)	*
9	DGB9940	Housing c/w Bearings, Seals, Sleeve, Snap Rings, & Cap (T2-215 Series)	*
10	DG9901	Housing Only (T2-215 Series)	*
11	DG9905	Bearing Seal (National #200322)	*
12	DG9904	#6215 Ball Bearing (Modified)	*
13	DG9922	9" (229mm) Steel Sleeve	*
14	DG9902	Bearing Housing Cap	*
15	DG9911	External Snap Ring (Philip French #D1400-75)	*
16	DG9910	Internal Snap Ring (Philip French #D1300-130)	*
17	DG9919	10-1/2" & 12" (267 & 305mm) Spacing (Press On) Short Half Spool (Convex Side)	*
18	DG9918	10-1/2" (267mm) Spacing, (Press On) Long Half Spool (Concave Side)	*
	DG9917	12" (305mm) Spacing (Press On) Long Half Spool (Concave Side)	*
19	DGA101	10-1/2" (267mm) Spacing, Full Spool w/6" (152mm) Dia. Washer on Both Ends, Spool	*
	DGA111	12" (305mm) Spacing, Full Spool w/ 6" (152mm) Dia. Washer on Both Ends, Spool	*
20	DGA35	Socket Wrench	*
21	DG10310	7/16" (10.9mm) x 3" (76.2mm) Lock Pin	*
22	DG5379	7/8" (22.2mm) x 6" (152mm) x 5-7/8" (149mm) Long U-Bolt (Plated)	*
23	BO62100	5/8" (15.7mm) x 10" (254mm) N.C. Hex Bolt Gr.5 (Plated) - Used on machines less bearing guard	*
24	BO62110	5/8" (15.7mm) x 11" (279.4mm) N.C. Hex Bolt Gr. 5 (Plated) - Used on Machines Equipped w/ Bearing Guard	*
25	BN087	7/8" (22.2mm) N.C. Hex Nut (Plated)	*

Item	Part #	Description	Qty
26	BN062L	5/8" (15.7mm) N.C. Hex Nylon Lock Nut	*
27	BW087L	7/8" (22.2mm) Lockwasher (Plated)	*
28	DGA5370	5-1/2" (139.7mm) End Plate - Weld On	*
29	DG9912	Set Screw - 1/4" (6.35mm) N.C. x 1/2" (12.7mm) Long	*
30	10GN1	1/4" (6.35mm) - 28 Straight Grease Fitting	*
31	DG10590	Bearing Guard - T2-215 Bearing	*
32	DGA13163	2" (50.8mm) Offset Trunion Mounted Bearing Hanger - (See Detail A for Length) - (w/o Scraper Tail)	*
	DGA13164	3-1/2" (88.9mm) Offset Trunion Mounted Bearing Hanger - (See Detail A for length) - (w/o Scraper Tail)	*
33	DG5371	Wrench Drive Plate - 1/2" x 3-1/2" x 3-1/2" (12.7 x 88.9 x 88.9mm)	*

* as required

Stone Flex Hanger for T2-215 Bearings (Optional)

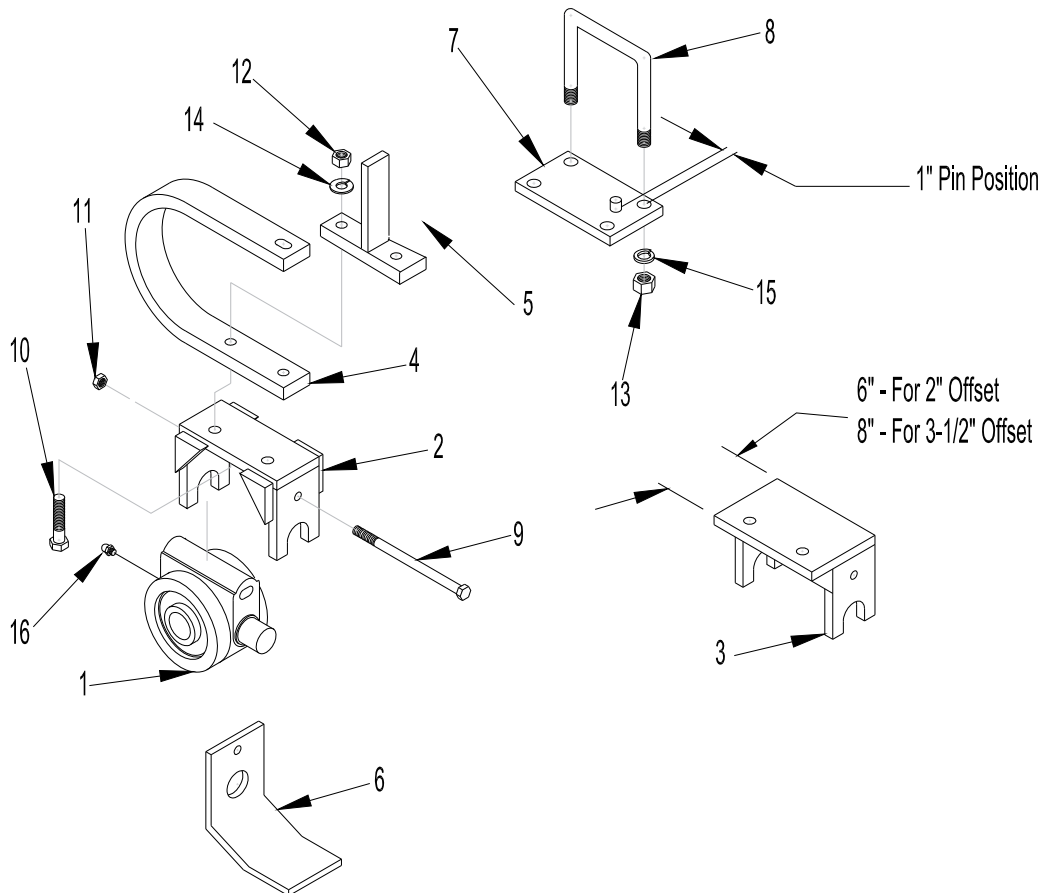

Item	Part #	Description	Qty
1	DGB9900	T2-215 Bearing Assembly	*
	DGB9990	T2-215 Bearing Assembly w/ 9" Interlocking sleeve	*
2	DGA10570	Standard Mounting Bracket	*
3	DGA10575	2" (50.8mm) Offset Mounting Bracket	*
	DCA10576	3-1/2" (88.9mm) Offset Mounting Bracket	*
4	DG5313	1-1/4" (31.8mm) x 2-1/2" (63.5mm) Spring Shank	*
5	DGA5330	Shank Stop	*
6	DGA5336	Scraper Bar Support Bracket - For 2" (50.8mm) Offset Mounting Bracket - Frt. L.H. & Rear R.H.	*
	DGA5337	Scraper Bar Support Bracket - For 2" (50.8mm) Offset Mounting Bracket - Frt. R.H. & Rear L.H.	*
7	DGA5328	Backing Plate - Hanger Mounted Scraper Only	*
8	DG5378	7/8" (22.2mm) x 7" (178mm) x 7-1/8" (181mm) Long U-Bolt	*
9	BO62100	5/8" (15.7mm) x 10" (254mm) N.C. Hex. Bolt - Gr.5	*
10	BO75035	3/4" (19mm) x 3-1/2" (88.9mm) N.C. Hex. Bolt - Gr.5	*
11	BN062	5/8" (15.7mm) N.C. Hex Nylon Lock Nut	*
12	BN075	3/4" (19mm) N.C. Hex Nut	*
13	BN087	7/8" (22.2mm) N.C. Hex Nut	*
14	BW075L	3/4" (19mm) Lockwasher	*
15	BW087L	7/8" (22.2mm) Lockwasher	*
16	10GN1	1/4" (6.35mm) - 28 Straight Grease Fitting	*
17	DG10590	Bearing Guard - T2-215 Bearing	*

* as required

Standard Scraper and Scraper Bar

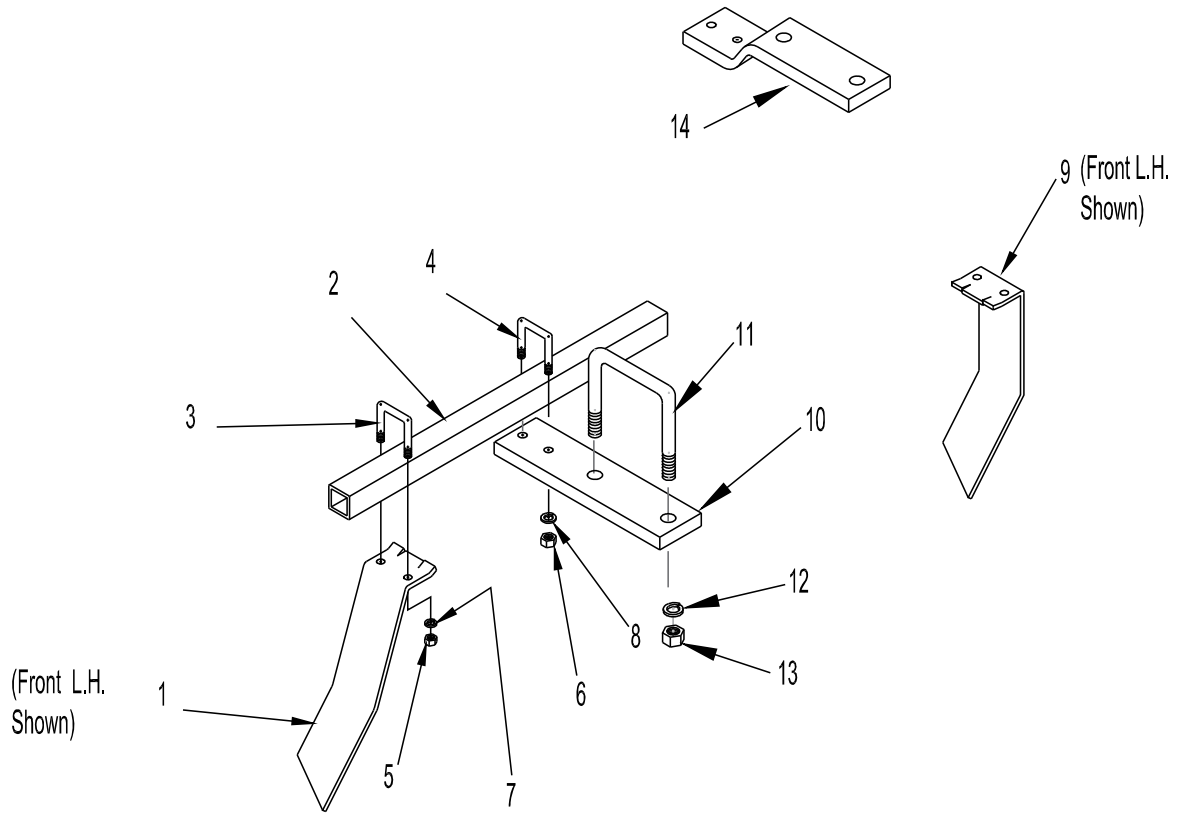

Item	Part #	Description	Qty
1	DG5292	Scraper (Std) - Front L.H. & Rear R.H.	*
	DG5293	Scraper (Std) - Front R.H. & Rear L.H.	*

Scraper Bars for 9" (230mm) Spacing			
2	DS48	4 Blade Gang Scraper Bar - 48-1/2" (1232mm)	*
	DS67	7 Blade Gang Scraper Bar - 67" (1702mm)	*
	DS63	7 Blade Gang Scraper Bar - 63" (1600mm) - (90° Scraper)	*
	DS76	8 Blade Gang Scraper Bar - 76-1/4" (1937mm)	*
	DS85	9 Blade Gang Scraper Bar - 85" (2159mm)	*
	DS81	9 Blade Gang Scraper Bar - 81-1/2" (2070mm) - (90° Scraper)	*
	DS95	10 Blade Gang Scraper Bar - 95" (2413mm)	*
	DS91	10 Blade Gang Scraper Bar - 91-1/2" (2324mm) - (90° Scraper)	*
	DS104	11 Blade Gang Scraper Bar - 104-1/2" (2654mm)	*
	DS99	11 Blade Gang Scraper Bar - 99-1/2" (2527mm) - (90° Scraper)	*
	DS113	12 Blade Gang Scraper Bar - 113" (2870mm)	*
	DS108	12 Blade Gang Scraper Bar - 108" (2743mm) - (90° Scraper)	*
	DS132	14 Blade Gang Scraper Bar - 132-1/2" (3366mm)	*
	DS142	15 Blade Gang Scraper Bar - 142" (3607mm)	*
	DS138	15 Blade Gang Scraper Bar - 138" (3505mm) - (90° Scraper)	*

Scraper Bars for 10-1/2" (267mm) Spacing			
	DS43	4 Blade Gang Scraper Bar - 43" (1092mm)	*
	DS65	6 Blade Gang Scraper Bar - 65-1/2" (1664mm)	*
	DS61	6 Blade Gang Scraper Bar - 61" (1549mm) - (90° Scraper)	*
	DS69	6 Blade Gang Scraper Bar - 69" (1753mm) - for Rear Centre M/F 6 Blade Gang Only	*
	DS76	7 Blade Gang Scraper Bar - 76-1/2" (1943mm)	*
	DS73	7 Blade Gang Scraper Bar - 73" (1854mm) - (90° Scraper)	*
	DS87	8 Blade Gang Scraper Bar - 87" (2210mm)	*
	DS82	8 Blade Gang Scraper Bar - 82-1/2" (2096mm) - (90° Scraper)	*
	DS97	9 Blade Gang Scraper Bar - 97-1/2" (2477mm)	*
	DS93	9 Blade Gang Scraper Bar - 93" (2362mm) - (90° Scraper)	*
	DS108	10 Blade Gang Scraper Bar - 108" (2743mm)	*
	DS107	10 Blade Gang Scraper Bar - 107-1/2" (2731mm) - (90° Scraper)	*
	DS118	11 Blade Gang Scraper Bar - 118-1/2" (3010mm)	*
	DS114	11 Blade Gang Scraper Bar - 114-1/2" (2908mm) - (90° Scraper)	*
	DS130	12 Blade Gang Scraper Bar - 130-1/2" (3315mm)	*
	DS141	13 Blade Gang Scraper Bar - 141" (3581mm)	*
	DS137	13 Blade Gang Scraper Bar - 137" (3480mm) - (90° Scraper)	*

Item	Part #	Description	Qty
Scraper Bar for 12" (305mm) Spacing			
	DS48	4 Blade Gang Scraper Bar - 48-1/2" (1232mm)	*
	DS73	6 Blade Gang Scraper Bar - 73" (1854mm)	*
	DS69	6 Blade Gang Scraper Bar - 69" (1753mm) - (90° Scraper)	*
	DS85	7 Blade Gang Scraper Bar - 85" (2159mm)	*
	DS81	7 Blade Gang Scraper Bar - 81" (2057mm) - (90° Scraper)	*
	DS97	8 Blade Gang Scraper Bar - 97-1/2" (2477mm)	*
	DS93	8 Blade Gang Scraper Bar - 93" (2362mm) - (90° Scraper)	*
	DS110	9 Blade Gang Scraper Bar - 110" (2794mm)	*
	DS106	9 Blade Gang Scraper Bar - 106" (2692mm) - (90° Scraper)	*
	DS123	10 Blade Gang Scraper Bar - 123" (3124mm)	*
	DS128	11 Blade Gang Scraper Bar - 128" (3251mm)	*
	DS135	11 Blade Gang Scraper Bar - 135" (3429mm)	*
	DS147	12 Blade Gang Scraper Bar - 147" (3734mm)	*
	DS159	13 Blade Gang Scraper Bar - 159" (4039mm)	*
	DS155	13 Blade Gang Scraper Bar - 155" (3937mm) - (90° Scraper)	*
	DG5308	1/2" (12.7mm) x 2" (50.8mm) U-Bolt	*
3	DG5309	5/8" (15.7mm) x 2" (50.8mm) U-Bolt	*
4	BN050	1/2" (12.7mm) N.C. Hex Nut	*
5	BN062	5/8" (15.7m) N.C. Hex Nut	*
6	BW050L	1/2" (12.7mm) Lockwasher	*
7	BW062L	5/8" (15.7mm) Lockwasher	*
8	DG5297	90° Scraper Std - Frt. L.H. & Rear R.H.	*
9	DG5298	90° Scraper Std - Frt. R.H. & Rear L.H.	*
10	DG5296	Straight Scraper Mount Plate	*
11	DG13145	3/4" x 6-7/8" cc x 5-3/4" (19.0mm x 174.5mm x 146.0mm) U-Bolt	*
12	BW075L	3/4" (19.0mm) Lockwasher	*
13	BN075	3/4" (19.0mm) N.C. Hex Nut	*
14	DG5303	Offset Scraper Mount Plate	*

* as required

Heavy Duty Scraper and Scraper Bar Assembly

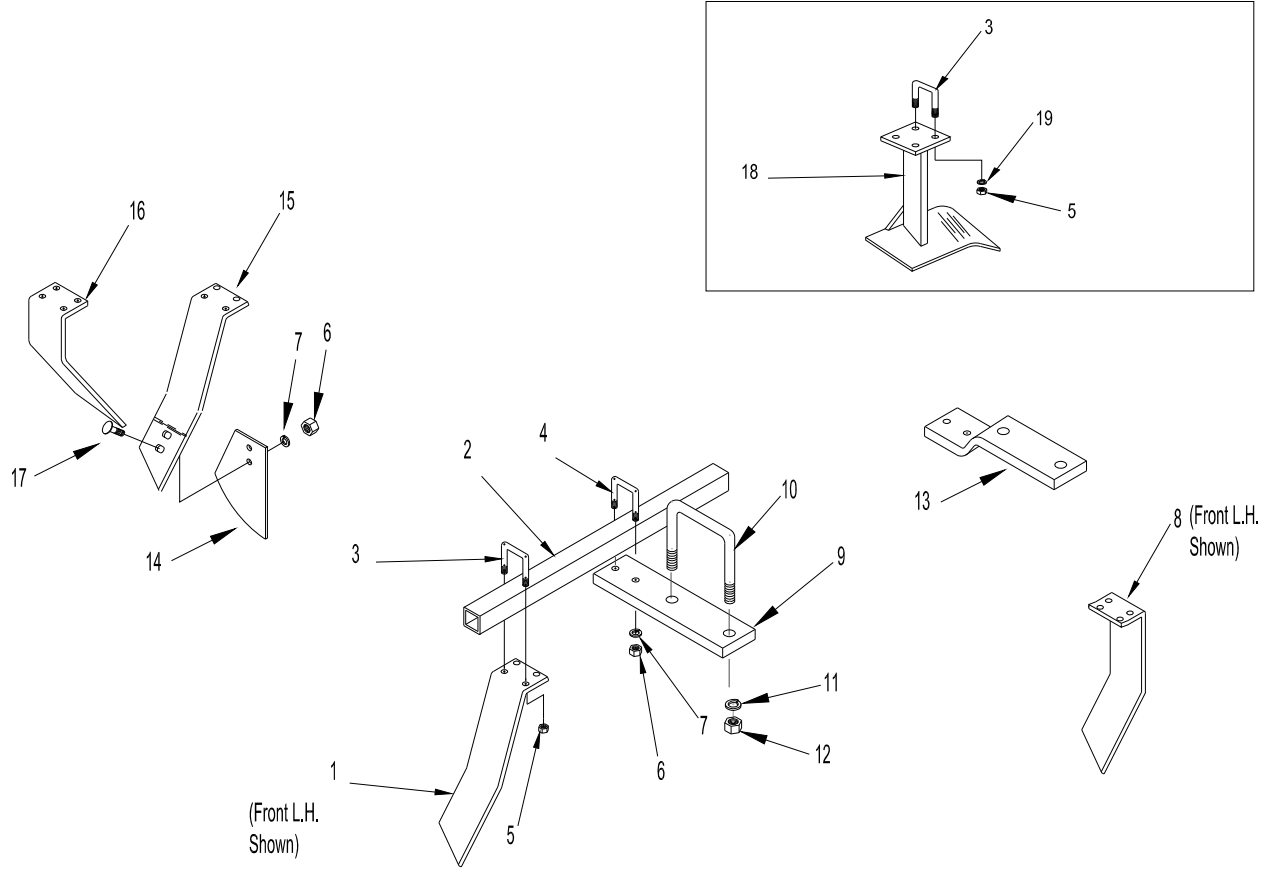

Item	Part #	Description	Qty
1	DG13215	Heavy Duty Scraper - 1/2" x 4" (12.7 x 101.6mm) - Front L.H. & Rear R.H.	*
	DG13216	Heavy Duty Scraper - 1/2" x 4" (12.7 x 101.6mm) - Front R.H. & Rear L.H.	*

Scraper Bars for 9" (230mm) Spacing - 3/16" Wall Tubing			
2	DS45 - 4	4 Blade Gang Scraper Bar - 45-1/2" (1156mm)	*
	DS64 - 4	7 Blade Gang Scraper Bar - 64" (1626mm)	*
	DS63 - 4	7 Blade Gang Scraper Bar - 63" (1600mm) - 90° Scraper)	*
	DS73 - 4	8 Blade Gang Scraper Bar - 73-1/4" (1861mm)	*
	DS82 - 4	9 Blade Gang Scraper Bar - 82" (2083mm)	*
	DS81 - 4	9 Blade Gang Scraper Bar - 82" (2083mm) - (90° Scraper)	*
	DS92 - 4	10 Blade Gang Scraper Bar - 92" (2337mm)	*
	DS88-4	10 Blade Gang Scraper Bar - 88-1/2" (2248mm) - (90° Scraper)	*
	DS101 - 4	11 Blade Gang Scraper Bar - 101-1/2" (2578mm)	*
	DS99 - 4	11 Blade Gang Scraper Bar - 99" (2515mm) - (90° Scraper)	*
	DS110 - 4	12 Blade Gang Scraper Bar - 110" (2794mm)	*
	DS108 - 4	12 Blade Gang Scraper Bar - 108" (2743mm) - (90° Scraper)	*
	DS129 - 4	14 Blade Gang Scraper Bar - 129-1/2" (3289mm)	*
	DS139 - 4	15 Blade Gang Scraper Bar - 139" (3531mm)	*
	DS135-4	15 Blade Gang Scraper Bar - 135" (3429mm) - (90° Scraper)	*

Scraper Bars for 9" (230mm) Spacing - 3/16" Wall Tubing			
	DS62 - 4	6 Blade Gang Scraper Bar - 62-1/2" (1588mm)	*
	DS61 - 4	6 Blade Gang Scraper Bar - 61" (1664mm) - (90° Scraper)	*
	DS73 - 4	7 Blade Gang Scraper Bar - 73-1/2" (1867mm)	*
	DS70 - 4	7 Blade Gang Scraper Bar - 70" (1778mm) - (90° Scraper)	*
	DS84-4	8 Blade Gang Scraper Bar - 84" (2134mm)	*
	DS82 - 4	8 Blade Gang Scraper Bar - 82-1/2" (2095mm) - (90° Scraper)	*
	DS94 - 4	9 Blade Gang Scraper Bar - 94-1/2" (2400mm)	*
	DS93 - 4	9 Blade Gang Scraper Bar - 93" (2362mm) - (90° Scraper)	*
	DS105 - 4	10 Blade Gang Scraper Bar - 105" (2667mm)	*
	DS107 - 4	10 Blade Gang Scraper Bar - 105" (2667mm) - (90° Scraper)	*
	DS115 - 4	11 Blade Gang Scraper Bar - 115-1/2" (2934mm)	*
	DS114 - 4	11 Blade Gang Scraper Bar - 115" (2921mm) - (90° Scraper)	*
	DS127-4	12 Blade Gang Scraper Bar - 127-1/2" (3239mm)	*
	DS138 - 4	13 Blade Gang Scraper Bar - 138" (3505mm)	*
	DS134 - 4	13 Blade Gang Scraper Bar - 138" (3505mm) - (90° Scraper)	*

Item	Part #	Description	Qty
Scraper Bars for 12" (305mm) Spacing - 3/16" Wall Tubing			
	DS45 - 4	4 Blade Gang Scraper Bar - 45-1/2" (1156mm)	*
	DS70 - 4	6 Blade Gang Scraper Bar - 70" (1778mm)	*
	DS66-4	6 Blade Gang Scraper Bar - 66" (1676mm) - (90° Scraper)	*
	DS82 - 4	7 Blade Gang Scraper Bar - 82" (2083mm)	*
	DS78 - 4	7 Blade Gang Scraper Bar - 78" (1981mm) - (90° Scraper)	*
	DS94 - 4	8 Blade Gang Scraper Bar - 94-1/2" (2400mm)	*
	DS90-4	8 Blade Gang Scraper Bar - 90" (2286mm) - (90° Scraper)	*
	DS107 - 4	9 Blade Gang Scraper Bar - 107" (2718mm)	*
	DS103-4	9 Blade Gang Scraper Bar - 103" (2616mm) - (90° Scraper)	*
	DS120 - 4	10 Blade Gang Scraper Bar - 120" (3048mm)	*
	DS103-4	10 Blade Gang Scraper Bar - 120" (3048mm) - (90° Scraper)	*
	DS132 - 4	11 Blade Gang Scraper Bar - 132" (3353mm)	*
	DS128 - 4	11 Blade Gang Scraper Bar - 128" (3264mm) - (90° Scraper)	*
	DS144 - 4	12 Blade Gang Scraper Bar - 144" (3658mm)	*
	DS156 - 4	13 Blade Gang Scraper Bar - 156" (3962mm)	*
	DS152 - 4	13 Blade Gang Scraper Bar - 152" (3861mm) - (90° Scraper)	*
3	DG5308	1/2" (12.7mm) x 2" (50.8mm) U-Bolt	*
4	DG5309	5/8" (15.7mm) x 2" (50.8mm) U-Bolt	*
5	BN050	1/2" (12.7mm) N.C. Hex Nut	*
6	BN062	5/8" (15.7mm) N.C. Hex Nut	*
7	BW062L	5/8" (15.7mm) Lockwasher	*
8	DG13217	90° Heavy Duty Scraper - 1/2" x 4" (12.7 x 101.6mm) - Frt. L.H. & Rear R.H.	*
	DG13218	90° Heavy Duty Scraper - 1/2" x 4" (12.7 x 101.6mm) - Frt. R.H. & Rear L.H.	*
9	DG5296	Straight Scraper Mount Plate	*
10	DG13145	3/4" x 6-7/8" cc x 5-3/4" (19.0mm x 174.5mm x 146.0mm) U-Bolt	*
11	BW075L	3/4" (19.0mm) Lockwasher	*
12	BN075	3/4" (19.0mm) N.C. Hex Nut	*
13	DG5303	Offset Scraper Mount Plate	*
14	DG7190	Wide Pan Scraper	*
15	DG7194	Heavy Duty Scraper Holder - Wide Pan	*
16	DG7195	90 Deg. Heavy Duty Scraper Holder - Wide Pan	*
17	BO50012C	1/2" x 1-1/4" (12.7mm x 32mm) N.C. Carriage Bolt	*
18	DGA13225	Front L.H. Rear R.H. Bearing Trash Guard - 12" Spacing Only	*
	DGA13226	Front R.H. Rear L.H. Bearing Trash Guard - 12" Spacing Only	*

Item	Part #	Description	Qty
	DGA13227	Front L.H. Rear R.H. Bearing Trash Guard - 10-1/2" Spacing Only	*
	DGA13228	Front R.H. Rear L.H. Bearing Trash Guard - 10-1/2" Spacing Only	*
	BW050L	1/2" (12.7mm) Lockwasher	*

* as required

Warning Light Kit

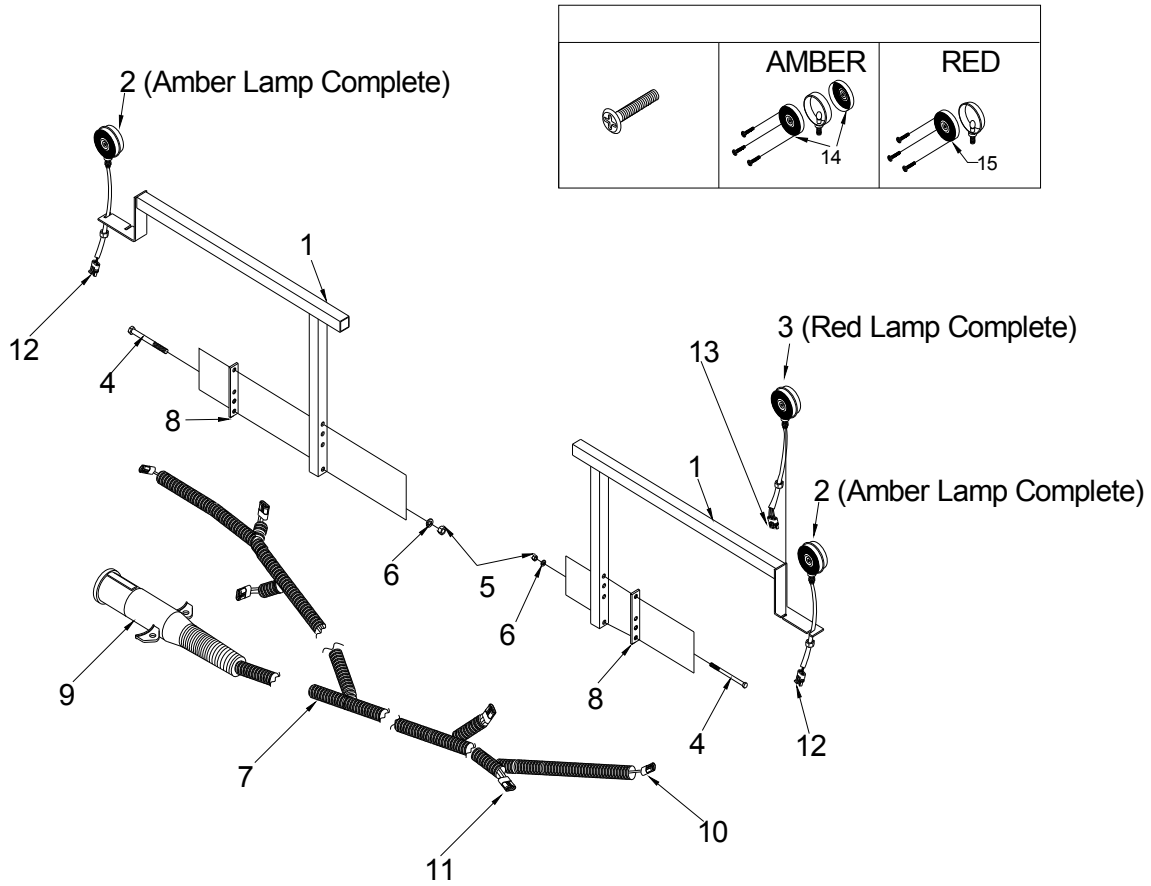

Item	Part #	Description	Qty
1	LK6411	Light Bracket	2
2	LK6426	Amber Lamp c/w Washers, Nut and 2 Pin Plug	2
3	LK6425	Red Lamp c/w Washers, Nut and 3 Pin Plug	1
4	BO50085	1/2" (12.7mm) x 7-1/2" (191mm) N.C. Hex Bolts (Plated)	4
5	BN050	1/2" (12.7mm) N.C. Hex Nut (Plated)	
6	BW050L	1/2" (12.7mm) Lockwasher (Plated)	8
7	LK6427	Wiring Harness	1
8	LK6404	Backing Plate	2
9	LK6423	Male Plug Complete	1
10	A75919	2 Pin Plug - Female	2
11	A75899	3 Pin Plug - Female	2
12	A75918	2 Pin Plug - Male	2
13	A75920	3 Pin Plug - Male	1
14	LK6429	Amber Lens	4
15	LK6430	Red Lens	1

Rockshaft Cylinder

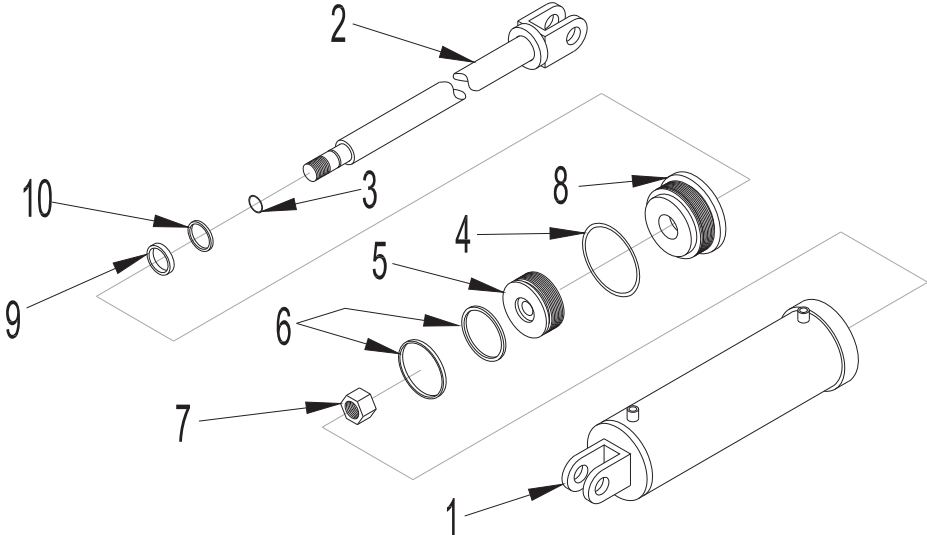

Item	Part #	Description	Qty
Main Rockshaft Cylinder - 4" (101.6mm) x 24" (610mm) Cylinder - #306			
1	40TU10	Tube Assembly - 4" (101.6mm) x 24" (610mm)	1
2	10SH60	Shaft - 2" (50.8mm) x 24" (610mm)	1
3	10OR18	1" (25.4mm) O.D. x 7/8" (22.2mm) I.D. O-Ring	1
4	10OR17	4" (101.6mm) O.D. x 3/16" (4.76mm) O-Ring	1
5	40PB8	Piston - 4" (101.6mm) O.D. x 1" (25.4mm) I.D.	1
6	40PS1	4" (101.6mm) O.D. Piston Seal Assembly	1
7	10NU4	1" (25.4mm) - 14 N.F. Hex Nut	1
8	40HP5	Head Plate - 4" (101.6mm) O.D. x 2" (50.8mm) I.D.	1
9	10RS2	Rod Seal - 2-3/8" (60.2mm) O.D. x 2" (50.8mm) I.D. x 3/8" (9.39mm)	1
10	10WS6	Wiper Seal - 2-1/2" (63.5mm) O.D. x 2" (50.8mm) I.D. x 3/8" (9.39mm) - All Urethane	1
L.H. Wing Rockshaft Cylinder - 3-1/2" (88.9mm) x 24" (610mm) Cylinder - #305			
	35TU15	Tube Assembly - 3-1/2" (88.9mm) x 24" (610mm)	1
	10SH59	Shaft - 1-3/4" (44.4mm) x 24" (610mm)	1
	10OR18	1" (25.4mm) O.D. x 7/8" (22.2mm) I.D. O-Ring	1
	10OR8	3-1/2" (88.9mm) O.D. x 3/16" (4.76mm) O-Ring	1
	35PB8	Piston - 3-1/2" (88.9mm) O.D. x 1" (25.4mm) I.D.	1
	35PS1	Piston Seal Assembly	1
	10NU4	1" (25.4mm) - 14 N.F. Hex Nut	1
	35HP9	Head Plate - 3-1/2" (88.9mm) O.D. x 1-3/4" (44.4mm) I.D.	1
	10RS3	Rod Seal - 1-3/4" (44.4mm) I.D. x 2-1/8" (54.0mm) O.D. x 3/8" (9.39mm)	1
	10WS10	All Urethane Wiper Seal - 1-3/4" (44.4mm) I.D. x 2-1/8" (54.0mm) O.D. x 1/4" (6.35mm)	1
R.H. Wing Rockshaft Cylinder - 3" (76.2mm) x 24" (610mm) Cylinder - #304			
1	30TU34	Tube Assembly - 3" (76.2mm) x 24" (610mm)	1
2	10SH59	Shaft - 1-3/4" (44.4mm) x 24" (610mm)	1
3	10OR18	1" (25.4mm) O.D. x 7/8" (22.2mm) I.D. O-Ring	1
4	10OR3	3" (76.2mm) O.D. x 3/16" (4.76mm) O-Ring	1
5	30PB4	Piston - 3" (76.2mm) O.D. x 1" (25.4mm) I.D.	1
6	30PS1	Piston Seal Assembly	1
7	10NU4	1" (25.4mm) - 14 N.F. Hex Nut	1
8	30HP15	Head Plate - 3" (76.2mm) O.D. x 1-3/4" (44.4mm) I.D.	1
9	10RS3	Rod Seal - 1-3/4" (44.4mm) I.D. x 2-1/8" (54.0mm) O.D. x 3/8" (9.39mm)	1
10	10WS10	All Urethane Wiper Seal - 1-3/4" (44.4mm) I.D. x 2-1/8" (54.0mm) O.D. x 1/4" (6.35mm) All Urethane Wiper Seal	1

* as required

Wing Lift Cylinder 4" x 36"

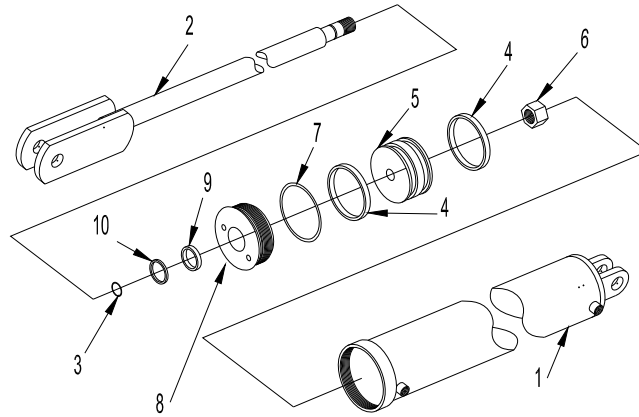

Wing Lift Cylinder 5" x 36"

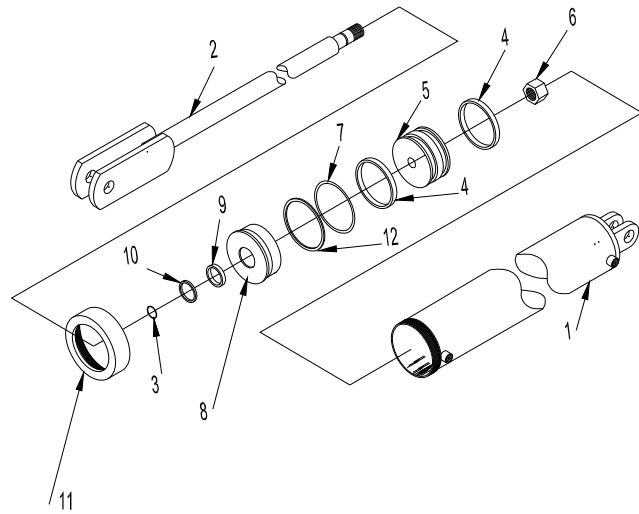

Item	Part #	Description	Qty
------	--------	-------------	-----

Wing Lift Cylinder - 4" x 36" (102 x 914mm) Cylinder - #248			
1	40TU8	Tube Assembly - 4" x 36" (102 x 914mm)	1
2	10SH36	Shaft - 1-3/4" x 36" (44.4 x 914mm)	1
3	10OR19	1-1/8" I.D. x 1-1/4" O.D. (28.5 x 31.8mm) O-Ring	1
4	40CU3	4" (101.6mm) U-Cup	2
5	40PB7	4" O.D. x 1-1/4" I.D. (101.6 x 31.7mm) Piston	1
6	10NU3	1-1/4" (31.8mm) U.N.F. Hex Lock Nut	1
7	10OR17	3-5/8" I.D. x 4" O.D. (92.1 x 101.6mm) O-Ring	1
8	40HP4	4" O.D. x 1-3/4" I.D. (101.6 x 44.4mm) Head Plate	1
9	10RS3	1-3/4" I.D. x 2-1/8" O.D. x 3/8" (44.4 x 54.0 x 9.39mm) Rod Seal	1
10	10WS3	1-3/4" I.D. x 2-1/8" O.D. x 3/16" (44.4 x 54.0 x 4.76mm) Wiper Seal	1

Wing Lift Cylinder - 5" x 36" (127 x 914mm) Cylinder - #332			
1	50TU11	N3 Tube Assembly - 5" x 36" (127 x 914mm)	1
2	10SH36	Shaft - 1-3/4" x 36" (44.4 x 914mm)	1
3	10OR19	1-1/8" I.D. x 1-1/4" O.D. (28.5 x 31.8mm) O-Ring	1
4	50CU1	4-1/2" I.D. x 5" O.D. x 1/2" (29.9 x 127 x 12.7mm) U-Cup	2
5	50PB2	5" O.D. x 1-1/4" I.D. (127 x 31.8mm) Piston	1
6	10NU3	1-1/4" (31.8mm) U.N.F. Hex Lock Nut	1
7	10OR14	4-1/2" I.D. x 5" O.D. (29.9 x 127mm) O-Ring	1
8	50HP5	5" O.D. x 1-3/4" O.D. (127 x 44.4mm) N3 Head Plate	1
9	10RS3	1-3/4" I.D. x 2-1/8" O.D. x 3/8" (44.4 x 54.0 x 9.39mm) Rod Seal	1
10	10WS3	1-3/4" I.D. x 2-1/8" O.D. x 3/16" (44.4 x 54.0 x 4.76mm) Wiper Seal	1
11	50HN1	5" N3 Type Head Nut	1
12	50BR1	5" O.D. x 4-1/2" I.D. (127 x 114mm) Backup Ring	1

Seal Kit - 5017N3 - Cylinder #332			
	50CU1	4-1/2" I.D. x 5" O.D. x 1/2" (114 x 127mm x 12.7mm) U-Cup	2
	10OR14	4-1/2" I.D. x 5" O.D. (114 x 127mm) O-Ring	1
	10OR19	1-1/8" I.D. x 1-1/4" O.D. (28.5 x 31.8mm) O-Ring	1
	10ORS3	1-3/4" I.D. x 2-1/8" O.D. x 3/8" (44.4 x 54.0 x 9.39mm) Rod Seal	1
	10WS3	1-3/4" I.D. x 2-1/8" O.D. x 3/16" (44.4 x 54.0 x 4.76mm) Wiper Seal	1
	10OR13	1" O.D. x 1-1/4" O.D. O-Ring (25.4 x 31.8mm)	1
	50BR1	5" O.D. x 4-1/2" I.D. Back Up Ring (127mm x 114mm)	1

Item	Part #	Description	Qty
------	--------	-------------	-----

Seal Kit - 4017N4 - Cylinder #248			
	40CU3	4" (101.6mm) U-Cup	2
	100R17	3-5/8" I.D. x 4" O.D. (92.1 x 101.6mm) O-Ring	1
	100R19	1-1/8" I.D. x 1-1/4" O.D. (28.4 x 31.7mm) O-Ring	1
	100RS3	1-3/4" I.D. x 2-1/8" O.D. x 3/8" (44.4 x 54.0 x 9.39mm) Rod Seal	1
	10WS3	1-3/4" I.D. x 2-1/8" O.D. x 3/16" (44.4 x 54.0 x 4.76mm) Wiper Seal	1
	100R13	1" O.D. x 1-1/4" O.D. O-Ring (25.4 x 31.8mm)	1

Seal Kit - 4020N4-0 - Cylinder #306			
	100R18	1" O.D. x 7/8" I.D. (25.4 x 22.2mm) O-Ring	1
	100R17	4" O.D. x 3/16" (101.6 x 4.76mm) O-Ring	1
	40PS1	4" (101.6mm) Piston Seal Assembly	1
	10RS2	2-3/8" O.D. x 2" I.D. x 3/8" (60.2 x 50.8 x 9.39mm) Rod Seal	1
	10WS6	2-1/2" O.D. x 2" I.D. x 3/8" (63.5 x 50.8 x 9/39mm) All Urethane Wiper Seal	1

Seal Kit - 3517N4-0 - Cylinder #305			
	100R18	1" O.D. x 7/8" I.D. (25.4 x 22.2mm) O-Ring	1
	100R8	3-1/2" O.D. x 3/16" (88.9 x 4.76mm) O-Ring	1
	35PS1	3-1/2" (88.9mm) Piston Seal Assembly	1
	10RS3	1-3/4" I.D. x 2-1/8" O.D. x 3/8" (44.4 x 54.0 x 9.39mm) Rod Seal	1
	10WS10	1-3/4" I.D. x 2-1/8" O.D. x 1/4" (44.4 x 54.0 x 6.35mm) All Urethane Wiper Seal	1

Seal Kit - 3017N4-0 - Cylinder #304			
	100R18	1" O.D. x 7/8" (25.4 x 22.2mm) I.D. O-Ring	1
	100R3	3" O.D. x 3/16" (76.2 x 4.76mm) O-Ring	1
	30PS1	3" (76.2mm) Piston Seal Assembly	1
	10RS3	1-3/4" I.D. x 2-1/8" O.D. x 3/8" (44.4 x 54.0 x 9.39mm) Rod Seal	1
	10WS10	1-3/4" I.D. x 2-1/8" O.D. x 1/4" (44.4 x 54.0 x 6.35mm) All Urethane Wiper Seal	1

Delivery Checklist

Pre-Delivery

- Torque all wheel bolts/lug nuts to specifications.
- Check tire pressures are correct. (Affects leveling process)
- Level machine. Refer to Operator's Manual for detailed instructions.
- Lubricate the entire machine as recommended in the Operator's Manual.
- Check tightness of all bolts.
- Check the correct # of depth stops are installed on mounting bar. (5)
*Model 395 Offset takes (8) depth stops.
- Set front and rear gangs at medium angle.
- Adjust scrapers so they come into contact with blades.
- Check Operator's Manual to ensure all decals are correctly installed.
- Connect disc to tractor with a suitable pin and then lift the hitch jack.
- Check hydraulic hoses are leak free and hydraulic cylinders are filled with oil.
- Adjust mounted harrows as required (if equipped).
- Check overlap measurement of front gangs.
- Check opening measurement between two inner blades of rear main frame gangs.
- Check all electrical components (safety lights) and connections.
- Ensure hydraulic lockout valves function properly.

Dealer Representative:

Date:

Customer Delivery

- Give the Operator's Manual to your customer.
- Inform your customer of all safety precautions, maintenance procedures, and proper operation of the disc.
- Verify correct serial number.
- Attach disc to tractor.
- Ensure hitch jack is in transport position.
- Connect hydraulics, wiring harness, safety chain, etc.
- Ensure machine functions properly. (Fold/unfold, no leaks, lights work, etc)
- Take the disc to a field (preferably where the ground is level, if possible) and perform all required leveling adjustments. Follow the Operator's Manual.
- Explain warranty and fill out registration
- Start tractor and run all controls so your customer understands the correct operation of the disc and ensure all functions of the disc are working properly.

Dealer Representative:

Date:

Farm King Limited Warranty

This document limits your warranty rights.

Base Limited Warranty

Buhler Industries Inc. provides this warranty only to original retail purchasers of its product. Buhler Industries Inc. warrants to such purchasers that all Buhler Industries Inc. manufactured parts and components used and serviced as provided for in the Operator's Manual shall be free from defects in materials and workmanship for a period following delivery to the original retail purchaser of 12 months (80 days for commercial applications). This limited warranty applies only to those parts and components manufactured by Buhler Industries Inc. Parts and components manufactured by others are subject to their manufacturer's warranties, if any.

Buhler Industries Inc. will fulfill this limited warranty by, at its option, repairing or replacing any covered part that is defective or is the result of improper workmanship, provided that the part is returned to Buhler Industries Inc. within thirty (30) days of the date that such defect or improper workmanship is, or should have been, discovered. Buhler Industries Inc. reserves the right to either inspect the product at the buyer's location or have it returned to the factory for inspection. Parts must be returned through the selling representative and the buyer must prepay transportation charges.

Buhler Industries Inc. will not be responsible for repairs or replacements that are necessitated, in whole or part, by the use of parts not manufactured by or obtained from Buhler Industries Inc. Under no circumstances are component parts warranted against normal wear and tear. There is no warranty on product pump seals, product pump bearings, rubber product hoses, pressure gauges, or other components that require replacement as part of normal maintenance. Also: Buckets and Bucket Tines carry no warranty, Bent Spears carry no warranty, Snowblower Fan Shafts carry no warranty, Mower Blades carry no warranty, Portable Auger Parts Have Two (2) Year Warranty, Loader Parts Have Two (2) Year Warranty. The purchaser is solely responsible for determining suitability of goods sold. This warranty is expressly in lieu of all other warranties expressed or implied. Buhler Industries Inc. will in no event be liable for any incidental or consequential damages whatsoever. Nor for any sum in excess of the price received for the goods for which liability is claimed.

Repair Parts Limited Warranty

Buhler Industries Inc. warrants Farm King replacement parts purchased after the expiration of the Buhler Industries Inc. Limited Warranty, and used and serviced as provided for in the Operator's Manual, to be free from defects in materials or workmanship for a period of thirty (30) days from the invoice date for the parts. Buhler Industries Inc. will fulfill this limited warranty by, at its option, repairing or replacing any covered part that is defective or is the result of improper workmanship, provided that the part is returned to Buhler Industries Inc. within thirty (30) days of the date that such defect or improper workmanship is, or should have been, discovered. Such parts must be shipped to Buhler Industries Inc. at the purchaser's expense.

What is Not Covered

Under no circumstances does this limited warranty cover any components or parts that have been subject to the following: negligence; alteration or modification not approved by Buhler Industries Inc.; misuse; improper storage; lack of reasonable and proper maintenance, service, or repair; normal wear; damage from failure to follow operating instructions; accident; and/or repairs that have been made with parts other than those manufactured, supplied, and or authorized by Buhler Industries Inc.

Authorized Dealer and Labor Costs

Repairs eligible for labor under this limited warranty must be made by Buhler Industries Inc. or an authorized Farm King dealer. Buhler Industries Inc. retains the exclusive discretion to determine whether it will pay labor costs for warranty repairs or replacements, and the amount of such costs that it will pay and the time in which the repairs will be made. If Buhler Industries Inc. determines that it will pay labor costs for warranty work, it will do so by issuing a credit to the dealer's or distributor's account. Buhler Industries Inc. will not approve or pay invoices sent for repairs that Buhler Industries Inc. has not previously approved. Warranty service does not extend the original term of this limited warranty.

Warranty Requirements

To be covered by warranty, each Farm King new product must be registered with Buhler Industries Inc. within thirty (30) days of delivery to original retail purchaser. If the customer decides to purchase replacement components before the warranty disposition of such components is determined, Buhler Industries Inc. will bill the customer for such components and then credit the replacement invoice for those components later determined to be covered by this limited warranty. Any such replacement components that are determined not be covered by this limited warranty will be subject to the terms of the invoice and shall be paid for by the purchaser.

Warranty Claims:

Warranty requests must be prepared on Buhler Industries Inc. Warranty Claim Forms with all requested information properly completed. Warranty Claims must be submitted within a thirty (30) day period from date of failure repair.

Warranty Labor:

Any labor subject to warranty must be authorized by Buhler Industries Inc. The labor rate for replacing defective parts, where applicable, will be credited at 100% of the dealer's posted shop rate.

Exclusive Effect of Warranty and Limitation of Liability

TO THE EXTENT PERMITTED BY LAW, BUHLER INDUSTRIES INC. DISCLAIMS ANY WARRANTIES, REPRESENTATIONS, OR PROMISES, EXPRESS OR IMPLIED, AS TO THE QUALITY, PERFORMANCE, OR FREEDOM FROM DEFECT OF THE COMPONENTS AND PARTS COVERED BY THIS WARRANTY AND NOT SPECIFICALLY PROVIDED FOR HEREIN.

TO THE EXTENT PERMITTED BY LAW, BUHLER INDUSTRIES INC. DISCLAIMS ANY IMPLIED WARRANTIES OF MERCHANTABILITY AND FITNESS FOR A PARTICULAR PURPOSE ON ITS PRODUCTS COVERED HEREIN, AND DISCLAIMS ANY RELIANCE BY THE PURCHASER ON BUHLER INDUSTRIES INC.'S SKILL OR JUDGMENT TO SELECT OR FURNISH GOODS FOR ANY PARTICULAR PURPOSE. THE PURCHASER'S ONLY AND EXCLUSIVE REMEDIES IN CONNECTION WITH THE BREACH OR PERFORMANCE OF ANY WARRANTY ON PRODUCTS MANUFACTURED BY BUHLER INDUSTRIES INC. ARE THOSE SET FORTH HEREIN. IN NO EVENT SHALL BUHLER INDUSTRIES INC. BE LIABLE FOR INCIDENTAL OR CONSEQUENTIAL DAMAGES (INCLUDING, BY WAY OF EXAMPLE ONLY AND NOT LIMITATION, LOSS OF CROPS, LOSS OF PROFITS OR REVENUE, OTHER COMMERCIAL LOSSES, INCONVENIENCE, OR COST OF REPLACEMENT OF RENTAL EQUIPMENT). IN NO EVENT SHALL FARM KING'S CONTRACT OR WARRANTY LIABILITY EXCEED THE PURCHASE PRICE OF THE PRODUCT.

(Note that some provinces or states do not allow limitations on how long an implied warranty lasts or the exclusion or limitation of incidental or consequential damages, so the above limitations and exclusion may not apply to you.) This warranty gives you specific legal rights and you may also have other rights, which vary from province to province or state to state.

Buhler Industries Inc. neither assumes nor authorizes any person or entity, including its selling representatives, to assume any other obligations or liability in connections with the sale of covered equipment, or to make any other warranties, representations, or promises, express or implied, as to the quality, performance, or freedom from defect of the components and parts covered herein. No one is authorized to alter, modify, or enlarge this limited warranty, or its exclusions, limitations and reservations.

Corrections of defects and improper workmanship in the manner, and for the applicable time periods, provided for herein shall constitute fulfillment of all responsibilities of Buhler Industries Inc. to the purchaser, and Buhler Industries Inc. shall not be liable in negligence, contract, or on any other basis with respect to the subject equipment.

This limited warranty is subject to any existing conditions of supply which may directly affect Buhler Industries Inc.'s ability to obtain materials or manufacture replacement parts.

Buhler Industries Inc. reserves the right to make improvements in design or changes in specifications to its products at anytime, without incurring any obligation to owners of units previously sold.

Government Legislation:

Warranty terms and conditions are subject to provincial or state legislation.

Important Note: This warranty does not apply to rentals.

www.farm-king.com

Farm King

5110 - 62nd Street
Vegreville, Alberta Canada, T9C 1N6
Ph.: 204.822.4467 | Fax: 204.822.6348
Toll Free: 888.524.1004
E-mail: info@buhler.com
www.farm-king.com

Equipment shown is subject to change without notice.
©2011 Buhler Trading Inc. Printed in Canada TSX:BU1

bühler | a division of Buhler Industries Inc.