

Farm King

OPERATOR AND PARTS MANUAL

Tandem Disc

4590 Model - Medium Duty - 3 Section

Table of Contents

Introduction	5
Safety.....	6
• Safety Instructions	6
• General Safety.....	7
• Assembly Safety	7
• Maintenance Safety	8
• Transport Safety	9
• Operation Safety	9
• Safety Decals.....	10
• Storage	10
Specifications.....	11
• Tires	11
• Hydraulic Cylinders.....	11
Assembly.....	12
• Hydraulic System	20
• Wing Beam Extensions	33
• Gang Pattern - 8" Spacing - 82/22	34
• Gang Pattern - 8" Spacing - 94/24.....	34
• Gang Pattern - 8" Spacing - 106/30	35
• Gang Pattern - 8" Spacing - 114/30.....	35
• Gang Pattern - 8" Spacing - 122/34	36
• Gang Pattern - 9" Spacing - 74/22	37
• Gang Pattern - 9" Spacing - 82/22	37
• Gang Pattern - 9" Spacing - 86/24.....	38
• Gang Pattern - 9" Spacing - 94/28.....	38
• Gang Pattern - 9" Spacing - 102/30	39
• Gang Pattern - 9" Spacing - 106/30	39
Operation	40
Maintenance	48

Troubleshooting	52
Parts	54
• Frame Assembly	54
• Frame Assembly Parts List.....	55
• Gang Beam Assembly	56
• Gang Beam Assembly Parts List.....	57
• Decals (Frame and Gang Beam)	58
• Decals (Frame and Gang Beam) Parts List.....	59
• Hitch and Leveling Crank Assembly.....	60
• Hitch and Leveling Crank Assembly	61
• Rockshaft and Wheel Assembly	62
• Rockshaft and Wheel Assembly Parts List.....	63
• Hydraulic Assembly - Wide and Narrow Wing.....	66
• Hydraulic Assembly - Wide and Narrow Wing Parts List	67
• Scraper Assembly	70
• Scraper Assembly Parts List.....	71
• Disc Gang Assembly.....	72
• Disc Gang Assembly Parts List	73
• Stone Flex Hanger Assembly.....	76
• Stone Flex Hanger Assembly Parts List	77
• Warning Light Kit (Optional)	78
• Warning Light Kit (Optional) Parts List.....	79
• Stabilizer Beam Assembly.....	80
• Stabilizer Beam Assembly Parts List	81
• Rockshaft Cylinder	82
• Rockshaft Cylinder Parts List.....	83
• Wing Lift Cylinder	84
• Wing Lift Cylinder Parts List.....	85
• Wing Weights	86
• Wing Weights	87
Delivery Checklist	88
Warranty	90

Introduction

Keep this manual handy for frequent reference. All new operators or owners must review the manual before using the equipment and at least annually thereafter. Contact your Farm King Dealer if you need assistance, information, or additional copies of the manual. Visit our website at www.buhlerindustries.com/ for a complete list of dealers in your area.

The directions left, right, front and rear, as mentioned throughout this manual, are as seen facing in the direction of travel of the implement.

Safety

Safety Instructions

Remember, YOU are the key to safety. Good safety practices not only protect you, but also the people around you. Make these practices a working part of your safety program. Be certain that everyone operating this equipment is familiar with the recommended operating and maintenance procedures and follows all the safety precautions. Most accidents can be prevented. Do not risk injury or death by ignoring good safety practices.

The alert symbol is used throughout this manual. It indicates attention is required and identifies hazards. Follow the recommended precautions.



The safety alert symbol means...
ATTENTION! BECOME ALERT! YOUR SAFETY IS INVOLVED!



CAUTION

The caution symbol indicates a potentially hazardous situation that, if not avoided, may result in minor or moderate injury. It may also be used to alert against unsafe practices.



WARNING

The Warning Symbol indicates a potentially hazardous situation that, if not avoided, could result in death or serious injury, and includes hazards that are exposed when guards are removed. It may also be used to alert against unsafe practices.



DANGER

The Danger Symbol indicates an imminently hazardous situation that, if not avoided will result in death or serious injury. This signal word is to be limited to the most extreme situations, typically for machine components that, for functional purposes, cannot be guarded.

General Safety

- Have a first-aid kit available for use and know how to use it. Have a fire extinguisher available, stored in a highly visible location, and know how to use it.
- Wear appropriate protective gear. This list may include but is not limited to:
 - hard hat
 - protective shoes with slip resistant soles
 - protective glasses or goggles
 - heavy gloves
 - wet weather gear
 - hearing protection
 - respirator or filter mask
- Read and understand the Operator's Manual and all safety signs before operating, servicing, adjusting, repairing, or unplugging the equipment.
- Do not attempt any unauthorized modifications to your Farm King product as this could affect function or safety, and could affect the life of the equipment.
- Inspect and clean the working area before operating.
- Keep hands, feet, clothing, and hair away from moving parts.
- Ensure bystanders are clear of the area before operating.
- Never allow anyone to ride on the tractor drawbar, or on the disc. The person(s) riding may fall and be seriously or fatally injured.
- Disc should be operated only by persons responsible and qualified to do so.
- Never allow anyone to climb or play on the tractor or disc. They may fall and be seriously injured.

Assembly Safety

- When assembling disc, use aligning punch to line up holes. Keep fingers out of holes. Any sudden movement of heavy components will severely injure or sever your fingers.
- Use adequate manpower or hoist to lift the heavy components into place. Attempting to lift heavy components by yourself could cause serious injury.
- Be sure all bolts and hydraulic fittings are tight, and all cotter pins are installed in the slotted nuts and pins.
- Support the main and wing frames securely before assembling the components. Inadequate support may result in the heavy components falling and causing serious injury to you or person(s) nearby.
- Be sure all wheel bolts are checked for tightness during initial transport or when first discing. Loose wheel bolts may result in the wheel falling off, causing serious damage to the disc and may cause serious injury to the operator or person(s) nearby.
- To fill the wing lift cylinders with hydraulic fluid, remove the pin from the shaft end of each wing lift cylinder and pump fluid into the cylinders. Extend and contract the cylinders until they are completely filled with hydraulic fluid. The wings will free-fall if the cylinders are not completely filled with fluid, resulting in serious damage to machine or serious injury or death to person(s) nearby.
- Do not raise or lower the main or wing frames until all components are securely tightened. Loose components will cause serious damage to the disc and serious injury or death to you and person(s) nearby if the main or wing frames fell.

- Hydraulic oil escaping under pressure has sufficient force to cause serious injury. Relieve pressure in all hydraulic components before disconnecting any hydraulic components. Before applying pressure to hydraulic system, be sure all connections are tight and components are not damaged. If injured by escaping hydraulic fluid, see a medical doctor immediately.
- When attaching gang assemblies, wear protective gloves to prevent injury from cutting edges of blades.
- Before applying pressure to the hydraulic system, be sure all connections are tight and the components are not damaged.
- Wings will free fall if wing cylinders is not full of oil causing serious damage to machine or serious injury or death to person(s) nearby.
- If hydraulic cylinder shafts are unpinned and cycled to fill them with oil, they can be seriously damaged if clevis of shaft strikes rockshaft arm or wing cylinder lug.
- Do not stand under folded wings when working on disc. If hydraulic system failed or if hydraulic lever was accidentally operated, wings may fall resulting in serious injury or death to person(s) near disc.
- When assembling gangs ensure adequate support is placed under main frame and wing frame. Do not use lock out valves as safety devise to prevent frame from falling. If any hydraulic component failed, disc could drop causing serious injury or death to person(s) nearby.

Maintenance Safety

- Do not loosen or disassemble hydraulic components when there is pressure within those components. Hydraulic components under pressure may cause parts and hydraulic fluid to fly out at a high velocity, which could cause serious injury. Always relieve the pressure in the hydraulic system before making adjustments to the hydraulic system. If injured by escaping hydraulic fluid, see a medical doctor immediately.
- Check all hydraulic hoses periodically for signs of ruptures and leaks. Always use wood or cardboard as a backstop, and wear gloves and eye protection when searching the hydraulic system for leaks. Spurting hydraulic fluid can cause injury if it penetrates the skin or the eyes. If injured by escaping hydraulic fluid, see a medical doctor immediately.
- Always relieve the pressure in the hydraulic system when the disc is not being operated.
- Always permit parts which contain hot fluid to cool to a safe temperature before handling or disconnecting these parts.
- Always wear safety glasses or goggles and gloves when working on the hydraulic system.
- To fill wing lift cylinders with hydraulic oil, extend and contract cylinder within slot on wing until cylinders are completely filled with oil. Do not fold wing until cylinder is completely filled, wing will free fall if cylinders are not filled with oil, causing serious damage to machine or serious injury or death to person(s) nearby.
- Lower the disc to the ground when servicing or making adjustments. If the disc must be serviced in the raised position, place blocks under frame. Do not rely on hydraulics lock up valves as a safety device. If the hydraulic system failed, or if the hydraulic lever was accidentally operated, the disc could drop.
- Do not lubricate disc while it is in motion. You may fall in front of disc and be seriously or fatally injured.
- Always place all tractor controls in neutral and lock brakes when hitching disc to tractor. Tractor could roll backwards when hitching disc.

- If a wing lift cylinders or wing lift hydraulic hoses are removed when wings are folded into transport position, always install a safety chain between wing frame and main frame to prevent wings from falling. If wings fell serious injury or death could occur to person(s) nearby and machine would be damaged severely.
- When inflating tires use a clip-on chuck and air hose extension which will allow operator to stand clear of tire and wheel assembly. Do not stand in front of or over tire when inflating. Exploding tire and wheel parts can cause serious injury or death.

Transport Safety

- When trailing the disc over public roads, use the SMV emblem and warning light for protection of tractor and other motor vehicle operators. Check local laws for width and height maximums.
- When transporting disc always place both hydraulic lock up valves in "closed" position. If hydraulic lever was accidentally operated the disc could drop or wings could fall causing serious injury or death to operator or person(s) nearby.
- Do not exceed 10 mph (16 km/h) when transporting the disc on smooth surfaces. Reduce speed when transporting on rough surfaces. Excessive speed could cause loss of tractor control and damage to disc and tractor. Do not transport the disc with any other vehicle except a tractor.
- When transporting disc always install the complete package of depth control stops (17" long) on shaft of main frame cylinder. If any component of hydraulic system failed disc could drop causing serious injury or death to operator or person(s) nearby.
- Disc may fall rearward suddenly and hitch may rise abruptly if disc is unpinned from tractor when disc is fully raised and wings unfolded. Always use caution and be sure other person(s) are not standing near disc when unhitching from tractor.
- When transporting the disc with the wings folded (UP), be sure there is sufficient clearance under all power lines and other overhead obstructions. Serious injury or death can result from contact with electrical lines. Use care to avoid contact with electrical lines when moving or operating the disc.
- Always attach a safety chain to the tractor drawbar and the disc hitch before transporting the disc. The safety chain will help control disc should it accidentally separate from the drawbar. Use a chain with a strength rating greater than the gross weight of the towed machine. Serious damage, injury or death could result from the disc separating from the tractor drawbar.
- Check all reflectors and visibility and cleanliness before transporting the disc. It is important that the reflectors are clean and visible, especially during the evening hours.
- Regulate your speed on hillsides and curves when transporting the disc. Loss of tractor control could result in serious damage to the disc and possible serious injury or death to you or person(s) nearby.
- Never allow anyone to ride on drawbar of the tractor or on the disc. The person riding may fall and be seriously injured.

Operation Safety

- Be sure person(s) are standing clear before starting or moving the tractor and disc.
- Only one (1) person (the operator) should be permitted on the tractor when the disc is in operation, and he/she should be familiar with repair procedures and temporary first aid treatment.
- Never stand between the tractor and disc when hitching disc to the tractor UNLESS all tractor controls are in neutral and the park brake is set. The tractor could roll backwards, which could result in serious injury or death to you or person(s) nearby.
- When operating on hillsides, use extreme care. The tractor may tip over if it strikes a hole, ditch or other irregularity.
- To avoid personal injury or death, always stay clear of the folding wing when it is being raised, lowered or in the folded position. If the hydraulic system failed, or if the hydraulic lever was accidentally operated, the wing could drop, resulting in serious injury or death to you or those nearby.
- Do not stand under wing while wing is being raised or lowered. If any components of hydraulic system should fail, or if hydraulic lever should accidentally be operated, wing could drop causing serious injury or death.
- Always relieve the pressure in the hydraulic system and close both hydraulic lockup valves when the disc is not being operated.

Safety Decals

- Keep all decals clean and in good condition to provide you with a constant reminder of safe operating procedures.
- Replace any destroyed, missing or illegible decals.

Storage

- Wings may unfold due to thermal expansion of hydraulic oil causing damage to disc, property or severe injury or death to person(s) nearby. Release pressure in all cylinders then close hydraulic lockup valves before unhitching from tractor or when parking with tractor.

Specifications

Model	Wing Width	Blade Spacing	Approx. Cutting Width	# of Blades	# of Gang Bearings	Gang Bearing Type	Approx. Transport Width	Approx. Transport Height
62N	Narrow	8"	28'	6.3e+2	2.22e+2	4.104e+29	17'0"	12'3"
94N	Narrow	8"	32'	2			17'0"	14'4"
106W	Wide	8"	35-1/2'				17'0"	15'8"
114W	Wide	8"	38'				17'0"	17'1"
122W	Wide	8"	40-1/2'				17'0"	17'9"
74N	Narrow	9"	28'				17'0"	12'7"
86N	Narrow	9"	32-1/2'				17'0"	14'2"
94W	Wide	9"	35-1/2'				17'0"	15'10"
102W	Wide	9"	38-1/2'				17'0"	17'5"
106W	Wide	9"	40'				17'0"	18'3"

Tires

Tire Location	Tire Sizes	Pressure
Center Frame - 28' to 35-1/2'	4 - 11L x 15 FI - Load Range D	50 PSI (345 KPA)
Center Frame - 38' to 40-1/2'	4 - 11L x 15 FI - Load Range F	60 PSI (414 KPA)
Wing Frame - 28' to 35-1/2"	2 - 11L x 15 FI - Load Range C	45 PSI (310 KPA)
Wing Frame - 38' to 40-1/2"	4 - 11L x 15 FI - Load Range C	45 PSI (310 KPA)

Hydraulic Cylinders

Application	Size	Required
Center Frame Lift	4" x 24" Rephasing	1
L.H. Wing Frame Lift	3-1/2" x 24" Rephasing	1
R.H. Wing Frame Lift	3" x 24" Rephasing	1
Wing Lift	5" x 36"	1

Gang Angle

- Front Gang - Fixed - 21 Degrees (Fixed)
- Rear Gang - Fixed - 19 Degrees (Fixed)

Bolt Torques

- Gang bolts - 1-15/16" (49mm) diameter 3200 ft lbs (4336 N.m)
- Leveling crank bolts - 1-1/4" (31mm) diameter 840 ft (1138.2 N.m)
- Wheel bolts - 9/16" (14mm) diameter 150 ft lbs (203.25 N.m)
- Bearing hanger u-bolts - 5/8" (15mm) diameter 150 ft lbs (203.25 N.m) (Solid Hangers)
- Bearing hanger u-bolts - 3/4" (19mm) diameter (352.3 N.m) (Solid Flex Hanger)

Assembly Instructions

fig 20 - need a drawing to go here

1. See FIG 20. Fasten L.H. center frame, arrow 1, and R.H. center frame half, arrow 2, together as shown. Center frame halves are fastened with four (4) 1" x 3-1/4" (25.4mm x 82.3mm) hex. bolts c/w nuts and lockwashers at each front, rear and inner connecting plates, arrow 3. Do not tighten bolts until after rockshaft bearings have been installed.
2. See FIG 20. Raise frame assembly, arrow 1 and 2, approximately 36" (914.4mm) from ground and block securely.
3. See FIG. 20. Fasten center frame rockshaft assembly, arrow 4, to bottom of main frame, with three (3) sets of 5-1/2" (139.7mm) rockshaft bearing halves, arrow 5. Position rockshaft so that outside bearings are positioned between wheel legs. Fasten each rockshaft bearing assembly to bearing bracket, arrow 6, with two (2) 3/4" x 6-1/2" (19.1mm x 165.1mm) hex bolts c/w nuts and lockwashers.

NOTE: Position top half bearing so grease hole is on rear side of rockshaft and bottom half so grease hole is on front side of rockshaft.

4. See FIG. 20. Tighten bolts which fasten rockshaft bearing halves, arrow 5, to frame. Next, tighten bolts which fasten frame connecting plates, arrow 3. If there is a gap between the plates, arrow 3, at top or bottom, install a 1-1/2" x 5" (38.1mm x 125.5mm) shim, arrow 9, to take up this gap.

NOTE: If gap is closed by tightening bolts, a preload will be placed on rockshaft bearing. Frame must be level after frame connecting plate bolts have been tightened.

NOTE: After tightening rockshaft bearing bolts, rockshaft should be free to pivot in bearings. If bearings are too tight, place two (2) 2" x 3" (50.8mm x 76.8mm) shim(s), arrow 7, (as required) between bearing halves, arrow 5.

NOTE: Before installing rockshaft bearings, place a coat of grease on bearing surface.



CAUTION

Support center frame securely before assembling components. Inadequate support may result in the heavy components falling and causing serious injury to you or person(s) nearby.

5. See FIG. 20. Install one (1) 1/4" x 28 (6.35mm x 28) grease fitting, arrow 8, in each top rockshaft bearing half. Install one (1) 1/4" x 28 (6.35mm x 28) grease fitting, arrow 9, in each bottom rockshaft bearing half.
6. See FIG. 20. Install one (1) eight bolt tire and wheel assembly, arrow 10, to hub assembly, arrow 11, on each side of each wheel leg. Center frame uses four (4) 12.5L x 15FI, range F tires. Secure with eight (8) 9/16" x 1-11/16" (14.3mm x 17.5mm) wheel bolts, arrow 12. Tighten wheel bolts to 130 ft. Lbs (176.3 N.m). Lock each wheel bolt by installing one (1) 9/16" (14.3mm) N.F. hex nut, arrow 13, on thread that extends past hub. Tighten nuts.

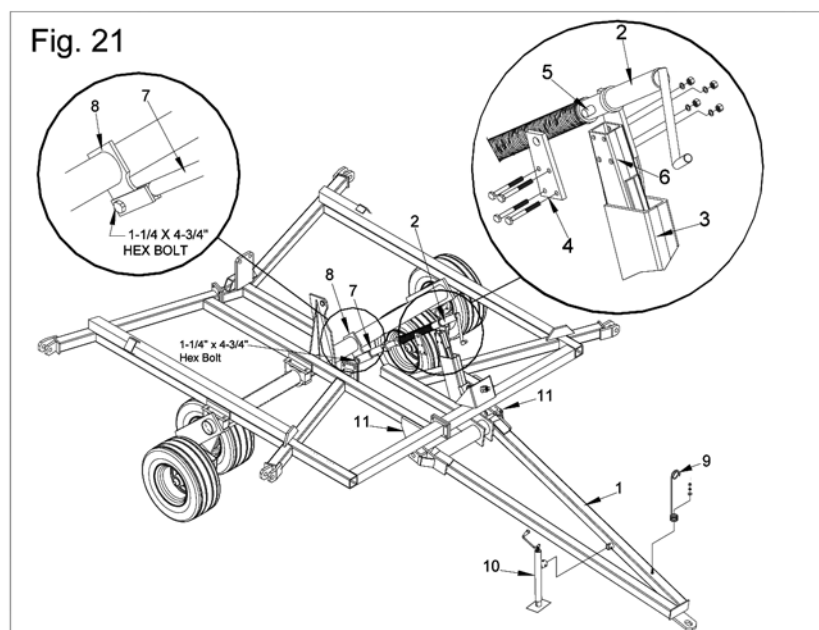

7. See FIG. 21. Attach hitch assembly, arrow 1, to hitch lugs, arrow 11, on center frame with two (2) 1-1/2" dia. x 5" (31.8mm x 127mm) pins. Secure each pin with one (1) 7/16" (11.1mm) lynch pin.
8. See FIG. 21. To attach levelling crank, arrow 2, to levelling arm, arrow 3, remove bolt-on lug, arrow 4, of hitch levelling arm. Next, install 1" (25.4mm) diameter pin of bearing tube, arrow 5, into weld-on lug, arrow 6, of leveling arm. Position bearing tube so grease fitting is facing up. Place bolt on lug, arrow 4, over outside of levelling arm. Install 1" diameter pin of bearing tube into bolt on lug. Fasten the bolt-on lug to the levelling arm with four (4) 1/2" x 5" (12.7mm x 127mm) N.C. hex bolts c/w nuts and lockwashers. Tighten bolts.
9. See FIG. 21. Attach clevis end of levelling link, arrow 7, to arm, arrow 8, on rockshaft. Fasten with one (1) 1-1/4" x 4-3/4" (31.8mm x 120.7mm) hex bolt c/w nut and lockwasher. Tighten bolt to 840 foot pounds (1139 N.m).

NOTE: The 1-1/4" x 4-3/4" (31.6mm x 120.7mm) bolt must be tightened so that the clevis is drawn up tight against the ball joint in arm, arrow 7. Tighten bolt to 840 foot pounds (1139 N.m). Ball must also be free to pivot in socket. Lubricate ball with oil and turn in socket to make sure ball is free to pivot.

10. See FIG. 21. Fasten hose support, arrow 9, to a bolt welded to top of hitch. Secure with one (1) 5/8" (15.9mm) nut, one (1) 11/16" (17.5mm) I.D. flatwasher, and one (1) 5/8" (15.9mm) lockwasher. Tighten nut.
11. See FIG 21. Mount hitch jack, arrow 10, on round tube welded to inside of hitch. Jack pivots on mounting tube can be placed in vertical position for supporting disc hitch or horizontal position while disc is in motion. Lock jack in desired position with pin.

NOTE: Jack must be in horizontal position when disc is in motion. If jack is in vertical position when disc is in motion, jack may strike ground or obstruction on ground, causing severe damage to jack, be sure the crank of jack is not hanging below hitch when jack is in horizontal position. Place crank on top of hitch to avoid damage.

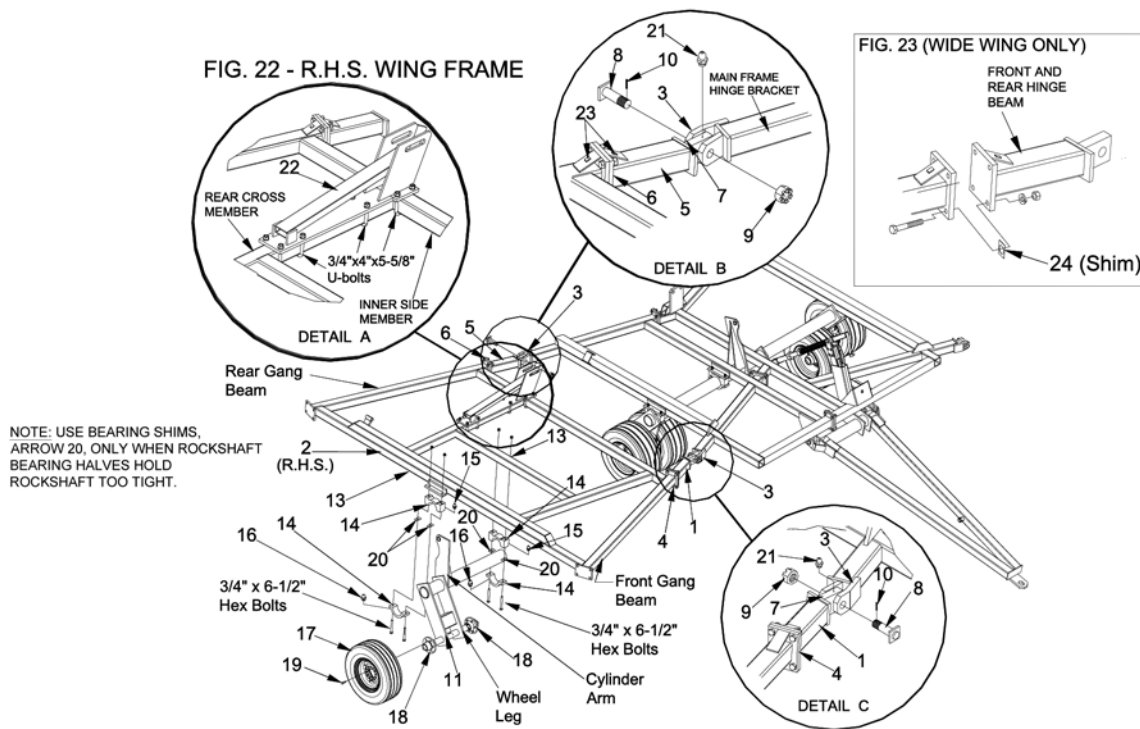

NOTE: There are two types of wing frames, wide wing and narrow wing. Wide wing machines use bolt-on type hinge beams, arrows 5 and 6. Narrow wing machines have beams that are part of the frame.

- See FIG. 22 and detail C. FOR WIDE WING DISCS ONLY. Fasten rear hinge beam, arrow 5, to a four (4) hole attaching plate, arrow 6, at rear inside of R.H. wing frame, arrow 2. The rear hinge beams are made L.H. and R.H., be sure R.H. beam is used for R.H. wing. Rear hinge beam can be identified by locating a small plate, arrow 23, that is welded to top connecting plate brace. The same type of plate is welded to connecting plate brace on wing frame. Fasten hinge beam with four (4) 1" x 3-1/4" (25.4mm x 82.6mm) hex bolts c/w lockwasher.

NOTE: See FIG. 22. Before tightening bolts check rear hinge beam alignment. Hinge beam must be aligned and level with rear gang beam of wing frame. Install shim(s), arrow 24, as required between attaching plates to align hinge beams. Tighten bolts.

- See FIG. 22 and detail C. FOR WIDE WING DISCS ONLY. Fasten front hinge beam, arrow 1, to a four (4) hole attaching plate, arrow 4, at front inside of R.H. wing frame, arrow 2. The front hinge beams are made L.H. and R.H., be sure R.H. beam is used for R.H. wing. The front hinge beam does not have a small plate, arrow 23, welded to top connecting plate brace like rear beam. Fasten hinge beam with four (4) 3/4" x 2-1/2" (19.1mm x 63.5mm) hex bolts c/w nuts and lockwashers.

NOTE: See FIG. 22. Before tightening bolts check front hinge beam alignment. Hinge beams must be aligned and level with front gang beam of wing frame. Install shim(s), arrow 24, as required between attaching plates to align hinge beams. Tighten bolts.

- See FIG. 22 and detail B and C. Fasten R.H. wing assembly, arrow 2, to center frame by connecting wing hinge brackets to center frame hinge brackets, arrow 3. Insert hinge lug, arrow 7, of wing frame into clevis of center frame hinge brackets. Fasten each hinge assembly to center frame with one (1) 1-1/2" x 5" (38.1mm x 120.7mm) threaded pin, arrow 8, and slotted nut, arrow 9. Install front bolt from front side and install rear bolt from rear side. Secure slotted nuts with one (1) 5/16" x 2" (7.94mm x 50.8mm) cotter pin, arrow 10. See details B and C.
- See FIG. 22. Fasten R.H. wing rockshafts, arrow 11, to bottom of R.H. wing frame. Be sure correct rockshaft is used for each wing. Wheel leg must point forward with cylinder arm on top. Secure each rockshaft to two (2) bearing brackets, arrow 13, with two (2) sets of 5-1/2" (139.7mm) rockshaft bearing halves, arrow 14. Fasten each rockshaft bearing assembly with two (2) 3/4" x 6-1/2" (19mm x 165mm) hex bolts c/w nuts and lockwasher. Position top half of rockshaft bearing so grease hole is at front. Position bottom half of rockshaft bearing so grease hole is at rear. Tighten rockshaft bearing bolts.

After tightening rockshaft bearing bolts, rockshaft should be free to pivot in bearings. If bearings are too tight, place two (2) 2" x 3" (50.8mm x 76.2mm) shim(s), arrow 20, (as required) between bearing halves.

NOTE: Before installing rockshaft bearings, place a coat of grease on bearing surface.

- See FIG. 22. Install one (1) 1/4" x 28 (6.35mm x 28) grease fitting, arrow 21, in each hinge lug, arrow 7, of front and rear wing hinge brackets. See details B and C.
- See FIG. 22. Install one (1) 1/4" x 28 (6.35mm x 28) grease fitting, arrow 15, in each top rockshaft bearing half. Install one (1) 1/4" x 28 (6.35mm x 28) grease fitting, arrow 16, in each bottom rockshaft bearing half.

18. See FIG. 22. Install one (1) 6 bolt tire and wheel assembly, arrow 17, to hub assembly, arrow 18, on each side of wheel leg. Wing frames use 11L x 15 FI Range C Tires. Secure with six (6) 9/16" x 1-1/8" (14.9mm x 28.6mm) wheel bolts, arrow 19. Tighten wheel bolts to 130 ft. Lbs.(176.3 N.m).
19. See FIG. 22 and Detail A. Fasten wing lift bracket, arrow 22 to top of rear cross member of each wing frame, arrows 1 and 2. Position bracket as shown. Secure each bracket with five (5) 3/4" x 4" x 5-5/8" (19mm x 101.6mm x 142.9mm) U-Bolts c/w nuts and lockwashers. Three (3) U-Bolts are used to fasten bracket to rear cross member and two (2) U-Bolts are used to fasten bracket to inner side member. Tighten U-Bolts.



WARNING Use adequate manpower or a hoist to lift heavy components into place. Attempting to lift heavy components by yourself could cause serious injury.



WARNING Support main frame securely before assembling components. Heavy frame could cause serious injury if it fell.



CAUTION When assembling disc, use aligning punch to line up holes. Keep fingers out of holes.

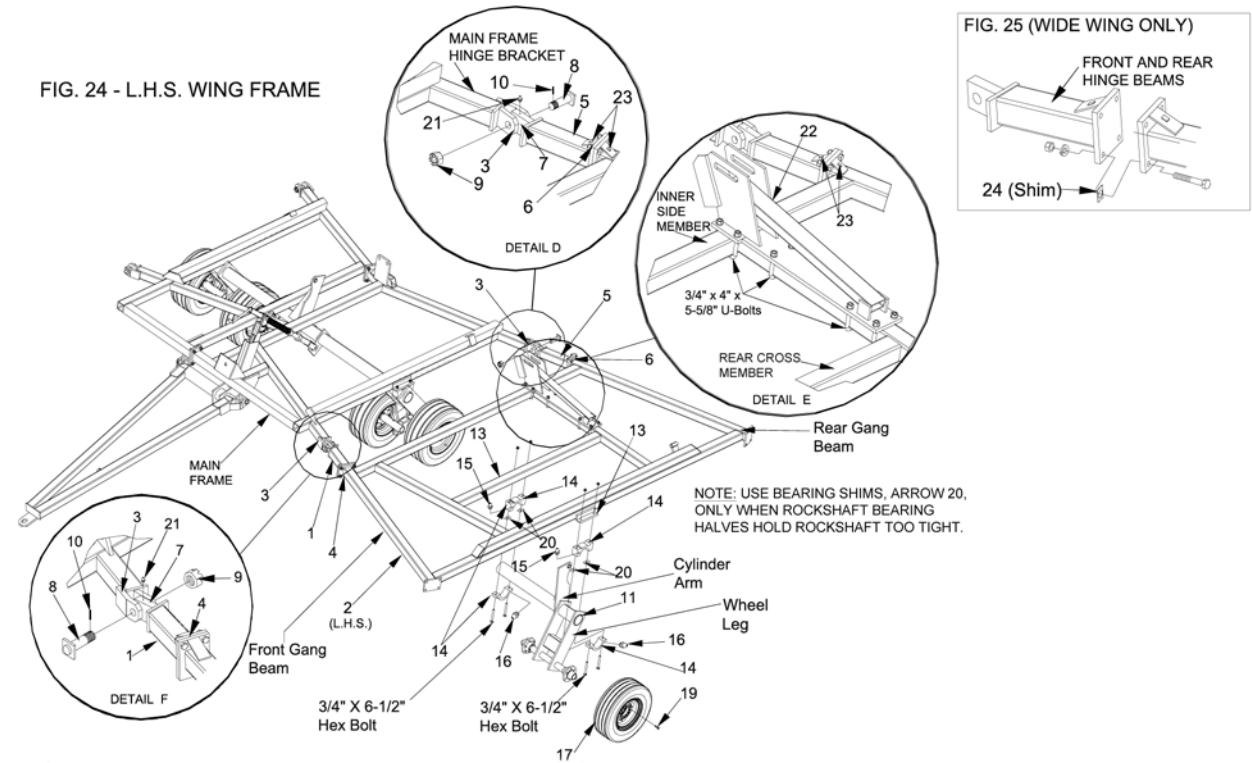

NOTE: There are two types of wing frames, wide wing and narrow wing. Wide wing machines use bolt-on type hinge beams, arrows 5 and 6. Narrow wing machines have beams that are part of the frame. Refer to specifications to determine type of wing your machine uses.

20. See FIG. 24 and Detail D. **For wide wing discs only.** Fasten rear hinge beam, arrow 5, to a four (4) hole attaching plate, arrow 6, at rear inside of R.H. wing frame, arrow 2. The rear hinge beams are made L.H. and R.H., be sure R.H. beam is used for R.H. wing. Rear hinge beam can be identified by locating a small plate, arrow 23, that is welded to top connecting plate brace. The same type of plate is welded to connecting plate brace on wing frame. Fasten hinge beam with four (4) 1" x 3-1/4" (25.4mm x 82.6mm) hex bolts c/w lockwasher.

NOTE: See FIG. 22. Before tightening bolts check rear hinge beam alignment. Hinge beams must be aligned and level with rear gang beam of wing frame. Install shim(s), arrow 24, as required between attaching plates to align hinge beams. Tighten bolts.

21. See FIG. 24 and Detail F. **For wide wing discs only.** Fasten front hinge beam, arrow 1, to a four (4) hole attaching plate, arrow 4, at front inside of R.H. wing frame, arrow 2. The front hinge beams are made L.H. and R.H., be sure R.H. beam is used for R.H. wing. The front hinge beam does not have a small plate, arrow 23, welded to top of connecting plate brace like rear beam. Fasten hinge beam with four (4) 3/4" x 2-1/2" (19.1mm x 63.5mm) hex bolts c/w nuts and lockwashers.

NOTE: See FIG. 22. Before tightening bolts check front hinge beam alignment. Hinge beams must be aligned and level with front gang beam of wing frame. Install shim(s), arrow 24, as required between attaching plates to align hinge beams. Tighten bolts

22. See FIG. 24 and Detail D and F. Fasten R.H. wing assembly, arrow 2, to center frame by connecting wing hinge brackets to center frame hinge brackets, arrow 3. Insert hinge lug, arrow 7, of wing frame into clevis of center frame hinge brackets. Fasten each hinge assembly to center frame with one (1) 1-1/2" x 5" (38.1mm x 120.7mm) threaded pin, arrow 8, and slotted nut, arrow 9. Install front bolt from front side and install rear bolt from rear side. Secure slotted nuts with one (1) 5/16" x 2" (7.94mm x 50.8mm) cotter pin, arrow 10. See Detail D and F.

23. See FIG. 24. Fasten R.H. wing rockshafts, arrow 11, to bottom of R.H. wing frame. Be sure correct rockshaft is used for each wing. Wheel leg must point forward with cylinder arm on top. Secure each rockshaft to two (2) bearing brackets, arrow 13, with two (2) sets of 5-1/2" (139.7mm) rockshaft bearing halves, arrow 14. Fasten each rockshaft bearing assembly with two (2) 3/4" x 6-1/2" (19mm x 165mm) hex bolts c/w nuts and lockwasher. Position top half of rockshaft bearing so grease hole is at front. Position bottom half of rockshaft bearing so grease hole is at rear. Tighten rockshaft bearing bolts. After tightening rockshaft bearing bolts, rockshaft should be free to pivot in bearings. If bearings are too tight, place two (2) 2" x 3" (50.8mm x 76.2mm) shim(s), arrow 19, (as required) between bearing halves.

NOTE: Before installing rockshaft bearings place a coat of grease on bearing surface.

24. See FIG. 24. Install one (1) 1/4" x 28 (6.35mm x 28) grease fitting, arrow 21, in each hinge lug, arrow 7, of front and rear wing hinge brackets. See Details D and F.
25. See FIG. 24. Install one (1) 1/4" x 28 (6.35mm x 28) grease fitting, arrow 15, in each top rockshaft bearing half. Install one (1) 1/4" x 28 (6.35mm x 28) grease fitting, arrow 16, in each bottom rockshaft bearing half.
26. See FIG. 24. Install one (1) 6 bolt tire and wheel assembly, arrow 17, to hub assembly, arrow 18, on each side of wheel leg. Wing frames use 11L x 15 FI Range C Tires. Secure with six (6) 9/16" x 1-1/8" (14.9mm x 28.6mm) wheel bolts, arrow 19. Tighten wheel bolts to 130 ft. lbs. (176.3 N.m).

27. See FIG. 24 and Detail E. Fasten wing lift bracket, arrow 22, to top of rear cross member of each wing frame, arrows 1 and 2. Position bracket as shown. Secure each bracket with five (5) 3/4" x 4" x 5-5/8" (19mm x 101.6mm x 142.9mm) U-Bolts c/w nuts and lockwashers. Three (3) U-Bolts are used to fasten bracket to rear cross member and two (2) U-Bolts are used to fasten bracket to inner side member. Tighten U-Bolts.



WARNING

Use adequate manpower or a hoist to lift heavy components into place. Attempting to lift heavy components by yourself could cause serious injury.



WARNING

Support main frame securely before assembling components. Heavy frame could cause serious injury if it fell.



CAUTION

When assembling disc, use aligning punch to line up holes. Keep fingers out of holes.

28. See FIG. 26. Fasten one (1) 4" x 24" (101.6mm x 609.6mm) lift cylinder, arrow 1, to main frame and rockshaft arm. Attach barrel end of cylinder to lug, arrow 2, Position cylinder so ports face L.H.S. Attach shaft end of cylinder to rockshaft arm, arrow 3. Fasten each end of cylinder with one (1) 1-1/4" x 4-3/4" (31.8mm x 120.7mm) pin. Secure cylinder pins with two (2) 5/16" x 2" (7.94mm x 50.8mm) cotter pins.
29. See FIG. 26. Fasten one (1) 3-1/2" x 24" (88.9mm x 609.6mm) rockshaft cylinder, arrow 4, to L.H. wing frame and rockshaft arm. Attach barrel end of cylinder to 1-1/4" x 8" (31.8mm x 203.2mm) I-Bolt, arrow 5. Position cylinder so ports face up. Attach shaft end of cylinder to rockshaft arm, arrow 6. Fasten each end of cylinder with one (1) 1-1/4" x 4-3/4" (31.8mm x 120.7mm) pin. Secure cylinder with two (2) 5/16" x 2" (7.94mm x 50.8mm) cotter pins.
30. See FIG. 26. Fasten one 3" x 24" (76.2mm x 609.6mm) rockshaft cylinder, arrow 7, to R.H. wing frame and rockshaft arm. Attach barrel end of cylinder to 1-1/4" x 8" (31.8mm x 203.2mm) I-Bolt, arrow 8. Position cylinder so ports face up. Attach shaft end of cylinder to rockshaft arm, arrow 9. Fasten each end of cylinder with one (1) 1-1/4" x 4-3/4" (31.8mm x 120.7mm) pin. Secure cylinder pins with two (2) 5/16" x 2" (7.94mm x 50.8mm) cotter pins.
31. See FIG. 26. Fasten two (2) 5" x 36" (120.7mm x 914.4mm) wing lift cylinders, arrows 10 and 11, to each side of lug, arrow 12, at rear of main frame. Position each cylinder so ports face towards front of disc. Fasten barrel end to each cylinder with one (1) 1-1/4" x 4-3/4" (31.8mm x 120.7mm) pin. Secure each pin with two (2) 5/16" x 2" (7.94mm x 50.8mm) cotter pins. Do not attach shaft ends at this time.



WARNING

Do not stand under wing while wing is being raised or lowered. If any component should fail, or if hydraulic lever should accidentally be operated, wing could drop.

	<p>CAUTION Wing will free fall if wing cylinders are not full of oil, causing serious damage.</p>
---	--

	<p>CAUTION When transporting disc, always place hydraulic lock up valves on "closed" position. If hydraulic lever was accidentally operated, disc could drop or wings could fall.</p>
---	--

FIG 26



Hydraulic System

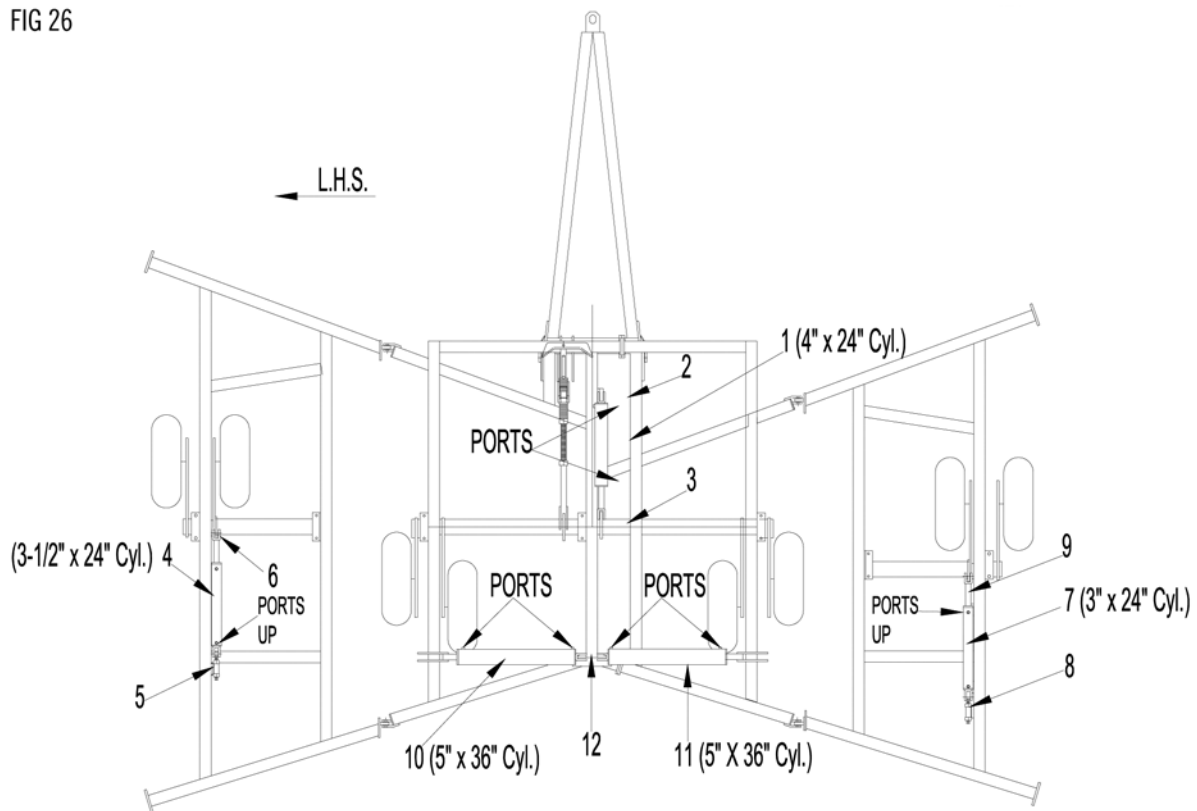
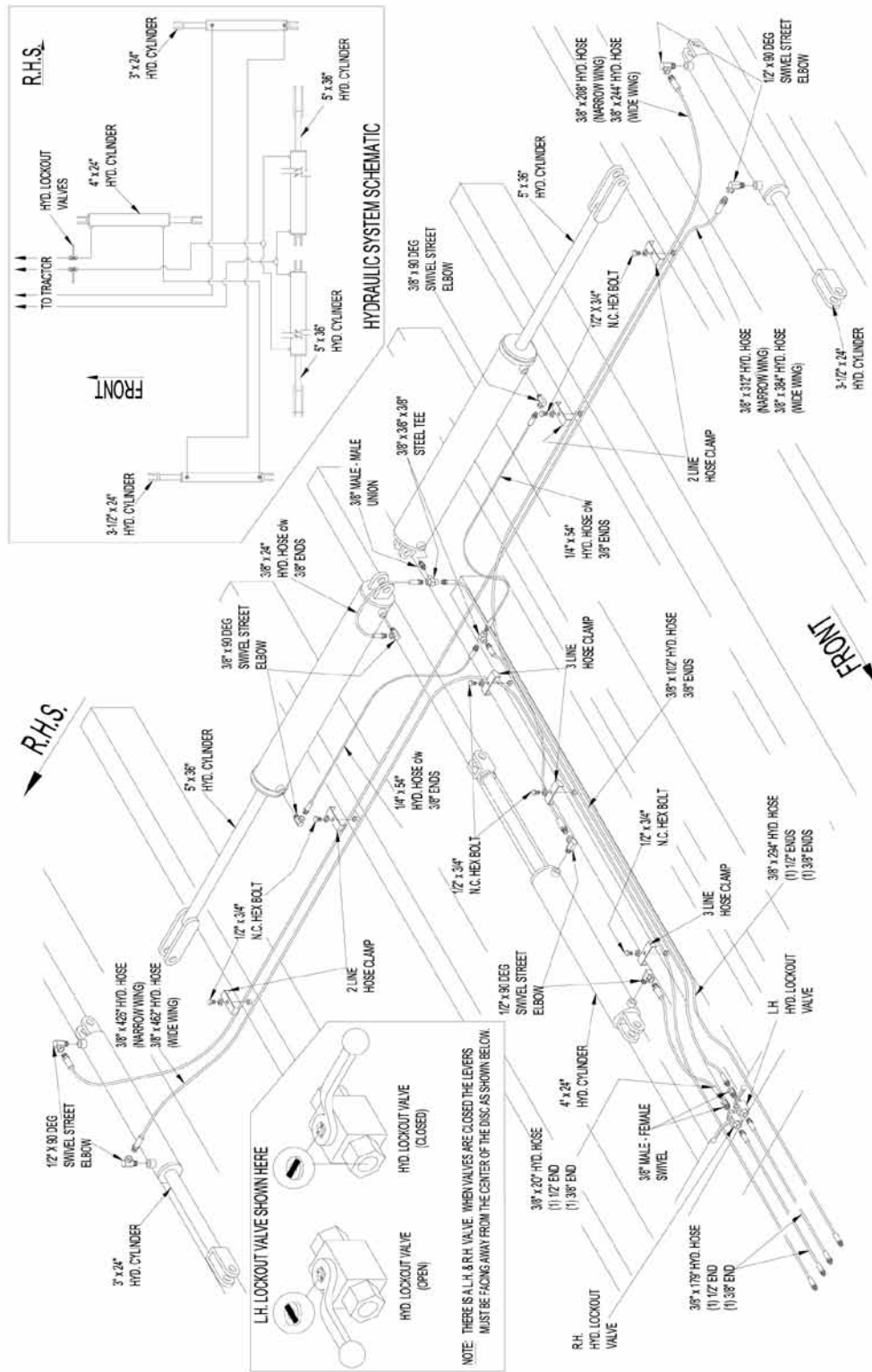

FIG. 27.

32. See FIG. 28. Place two (2) hydraulic lockup valves, arrows 1 and 2, between brackets, arrow 3, welded to front center of main frame. Each valve is held in place with incoming hoses.
33. Attaching hydraulic hoses to rockshaft cylinders and wing cylinders - See FIG. 19.

NOTE: Do not use teflon tape to seal hydraulic hoses and fittings. If pieces of tape get into the hydraulic system they may plug small orifices.

NOTE: To determine if your machine has a narrow or wide wing frame see specifications chart.

NOTE: To ensure that the hydraulic system does not leak, seal fittings and hoses with sealing liquid.

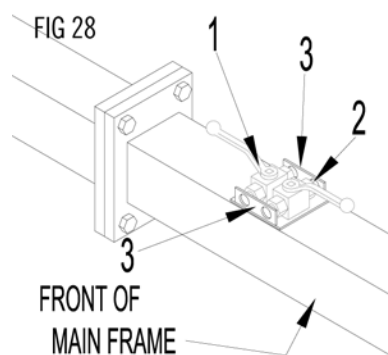

A - See FIG. 27. Install one (1) 1/2" (12.7mm) x 90 degree swivel street elbow, into the shaft end port of the 3" x 24" (76.2mm x 609.6mm) cylinder on R.H. wing. Connect one (1) 3/8" x 426" (9.53mm x 10820mm) hydraulic hose to the 1/2" (12.7mm) x 90 degree swivel street elbow. Narrow wing machines use a 3/8" x 426" (9.53mm x 10820mm) hose and wide wing machines use 3/8" x 462" (9.53mm x 11735mm) hose. Then run the hose across the wing frame to the center of the main frame, and to front of hitch.

B - See FIG. 27. Install one (1) 1/2" (12.7mm) x 90 degree swivel street elbow in shaft end port of the 3-1/2" x 24" (88.9mm x 609.6mm) cylinder on L.H. wing. Install one (1) 1/2" (12.7mm) x 90 degree swivel street elbow, in the barrel end port of the 3" x 24" (76.2mm x 609.6mm) cylinder on L.H. wing. Connect one (1) hydraulic hose, to swivel elbow, on R.H. cylinder. Narrow wing machines use a 3/8" x 312" (9.53mm x 7925mm) hose and wide wing machines use 3/8" x 384" (9.53mm x 9754mm) hose. Next, run hose across frame to the 1/2" (12.7mm) x 90 degree swivel elbow on L.H. cylinder.

C - See FIG. 27. Install one (1) 1/2" (12.7mm) x 90 degree swivel street elbow to barrel end port of the 3-1/2" x 24" (88.9mm x 609.6mm) cylinder on L.H. wing. Install one (1) 1/2" (12.7mm) x 90 degree swivel street elbow to shaft end port of 4" x 24" (101.6mm x 609.6mm) cylinder on main frame. Connect one (1) hydraulic hose, to swivel elbow, on main frame cylinder. Narrow wing machines use a 3/8" x 208" (9.53mm x 5283mm) hose and wide wing machines use 3/8" x 294" (9.53mm x 7468mm) hose. Next run same hose across frame to the 1/2" (12.7mm) x 90 degree swivel elbow on the 3-1/2" x 24" (88.9mm x 609.6mm) wing rockshaft cylinder.

D - See FIG. 27. Install one (1) 1/2" (12.7mm) x 90 degree swivel street elbow to barrel end port of 4" x 24" (101.6mm x 609.6mm) cylinder on main frame. Connect one (1) 3/8" x 20" (9.53mm x 508mm) hydraulic hose, to rear port of R.H. lock-up, with one (1) 3/8" (9.53mm) malefemale swivel. Next connect same hose to 1/2" (12.7mm) x 90 degree swivel elbow on front port of main frame cylinder.

E - See FIG. 27. Install one (1) 3/8" (9.53mm) male x 3/8" (9.53mm) male union, in the barrel end port of the 5" x 36" (127mm x 914.4mm) L.H. wing lift cylinder. Then install one (1) 3/8" x 3/8" x 3/8" (9.53mm) tee, to the 3/8" (9.53mm) union. Install one (1) 3/8" (9.53mm) x 90 degree street elbow into the shaft end of the 5" x 36" (127mm x 914.4mm) L.H. wing lift cylinder.

F - See FIG. 27. Install one (1) 3/8" (9.53mm) x 90 degree swivel street elbow into barrel end port of the 5" x 36" (127mm x 914.4mm) R.H. wing lift cylinder. Install one (1) 3/8" (9.53mm) x 90 degree street elbow into the shaft end port of same cylinder.

G - See FIG. 27. Install one (1) 1/4" x 54" (6.35mm x 1372mm) hydraulic hose to the shaft end port of the 5" x 36" (127mm x 914.4mm) L.H. wing lift cylinder and fasten opposite end to one (1) 3/8" x 3/8" x 3/8" (9.53mm) tee. Fasten one (1) 1/4" x 54" (6.35mm x 1372mm) hydraulic hose to the shaft end port of the 5" x 36" (127mm x 914.4mm) R.H. wing lift cylinder and fasten opposite end to same 3/8" x 3/8" x 3/8" (9.53mm) tee.

H - See FIG. 27. Install one (1) 3/8" x 24" (9.53mm x 609.6mm) hydraulic hose, to the barrel end port of the L.H. 5" x 36" (127mm x 914.4mm) wing lift cylinder and fasten opposite end to the barrel end port of the R.H. 5" x 36" (127mm x 914.4mm) wing lift cylinder.

I - See Fig. 27. Install one (1) 3/8" male x 3/8" (9.53mm) female swivel adapter, in to the L.H. lockup valve. Fasten one (1) 3/8" x 102" (9.53mm x 2591mm) hydraulic hose in 3/8" (9.53mm) tee. Fasten opposite end of same hose to the 3/8" male x 3/8" (9.53mm) female swivel adapter in lockup valve.

J - See FIG. 27. Install two (2) 3/8" x 179" (9.53mm x 4547mm) hydraulic hoses to the front port of hydraulic lockup valves, and run hoses to front of hitch.

K - See FIG. 27. Install one (1) 3/8" x 294" (9.53mm x 7468mm) hydraulic hose, from the 3/8" tee, to front of disc.

34. Securing hydraulic hoses to frame - See FIG. 27

Fasten hoses to frame with one U-shaped hose clamp at each hose hold down point. Each hold down point has a 1/2" (12.7mm) hex nut welded to the top of frame. The hold down clips are supplied in two widths, one for two hoses and the other for three hoses. Place hose clamp over hoses and fasten clamp to weld-on nut with one 1/2" x 3/4" (12.7mm x 19.1mm) bolt.

35. How main lift hydraulic system works - See FIG. 27

When raising the disc, oil is pumped into the barrel end port of center frame cylinder causing the cylinder to extend. Oil is then forced from the shaft end port of same cylinder into the barrel end port of the 3-1/2" x 24" (88.9mm x 610mm) cylinder on L.H. side causing wing cylinder to extend. Oil is then forced from the shaft end port of the 3-1/2" x 24" (88.9mm x 610mm) cylinder into the piston end port of the 3" x 24" (76.2mm x 610mm) wing cylinder on R.H.S. causing wing cylinders to extend. The oil from shaft end port of the 3" x 24" (76.2mm x 610mm) cylinder on R.H. S. is returned to the tractor.

When lowering the disc, oil flows from tractor to shaft end port of the 3" x 24" (76.2mm x 610mm) wing cylinder, causing wing cylinder to contract. Oil forced from piston end port of the 3" x 24" (76.2mm x 610mm) wing cylinder flows to shaft end port of L.H. 3-1/2" x 24" (88.9mm x 610mm) cylinder, causing cylinder to contract. The oil forced from the piston end port of the L.H. 3-1/2" x 24" (88.9mm x 610mm) wing cylinder flows to shaft end port of main frame 4" x 24" (101.6mm x 610mm) cylinder causing cylinder to contract. The oil from piston end port of the 4" x 24" (101.6mm x 610mm) cylinder is returned to the tractor.

NOTE: Lockup valve must be open to allow oil flow to and from lift cylinders.

All cylinders extend and contract at the same rate because the amount of oil flowing between the shaft end ports and the piston end ports is equal in volume. For example, the 4" x 24" (101.6mm x 610mm) main frame cylinder has a 2" (50.8mm) diameter piston shaft which displaces enough oil from the shaft side to fully extend the 3-1/2" x 24" (88.9mm x 610mm) L.H. wing cylinder. The same method is used between the 3- 1/2" x 24" (88.9mm x 610mm) L.H. wing cylinder and the 3" x 24" (76.2mm x 610mm) R.H. wing cylinder.

Each lift (rockshaft) cylinder contains a by-pass to allow oil to flow past piston when each cylinder is fully extended. If all cylinders are not fully extended when disc is raised, continue to pump oil into lift cylinders until all cylinders are fully extended.

36. Filling hydraulic cylinders with oil - See FIG. 27

NOTE: Before filling cylinders with oil, remove clevis pins from shaft end of each lift cylinder so that the cylinders may be extended and contracted without actuating rockshaft. Also place blocks under each hydraulic cylinder so shafts do not strike disc component when cylinders are extended.

A - Lift cylinders - To fill rockshaft cylinders with oil remove depth control stops to allow cylinders to work full length of stroke. Next, pump oil into the cylinders, extending cylinders. Hold hydraulic lever for (3) minutes allowing all cylinders to fully extend. Next, fully retract all cylinders then fully extend them and hold hydraulic level another (3) minutes. This procedure will purge air from all cylinders and fully synchronize them. Attach shaft end of each cylinder to rockshaft arm with one (1) 1-1/4" x 4-3/4" (31.7 mm x 121 mm) pin. Secure each pin with two (2) 5/16" x 1-3/4" (7.57 mm x 44.4 mm) cotter pins.

B - Wing lift cylinder - Pump oil in each direction into wing lift cylinders. After cylinders are completely filled with oil, fully extend them and fasten shaft end of each cylinder to wing lift bracket bolted to wings. Place clevis of cylinder shaft between two lugs which have slotted holes. Secure each cylinder shaft to slotted holes with one (1) 1-1/4" x 6" (31.8mm x 152.4mm) pin. Place one (1) 1-5/16" (33.3mm) I.D. flatwasher over pin on outside of cylinder lug. Secure each pin with one (1) 5/16" x 2" (7.94mm x 50.8mm) cotter pins.

**CAUTION**

Do not disconnect hydraulically operating components when there is pressure within those components. Hydraulic components under pressure may cause parts and hydraulic fluid to fly out at a high velocity which could cause serious injury.

**CAUTION**

Hydraulic oil escaping under pressure has sufficient force to cause serious injury. If injured by escaping fluid, obtain medical treatment immediately. Check hydraulic hoses periodically for signs of rupture and leaks. Use a cardboard backstop to check for escaping high pressure or hot fluid.

**CAUTION**

Wings will free fall if wing lift cylinders are not full of oil, causing serious damage.

**WARNING**

To assemble balance of disc, extend main lift cylinders raising frame. Be sure main lift cylinders are completely filled with oil. Next place adequate support under center frame and each wing frame. Do not use lock out valve as safety device prevent frame from falling. If any hydraulic component failed disc could drop causing serious injury or death to person(s) nearby.

**WARNING**

Do not stand under wings while wings are being raised or lowered. If any components of hydraulic system should fail or if hydraulic lever should accidentally be operated, wings could drop.

FIG 28

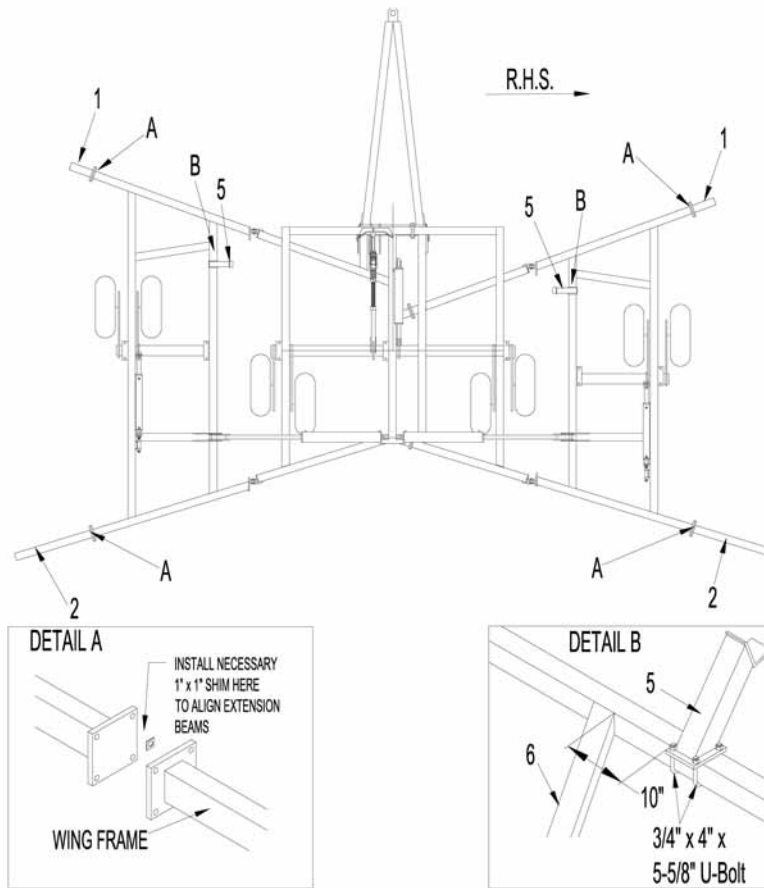

37. Attaching gang beam extensions - See FIG. 28

NOTE: See gang beam chart to determine length of gang beam extensions for the size of your disc.

A - Front wing - Attach front gang beam extension, arrow 1, to attaching plates that are welded to each wing frame. Fasten with four (4) 3/4" x 2-1/2" (19mm x 254mm) hex bolts c/w nuts and lockwashers. Tighten bolts.

B - Rear wing - Attach rear gang beam extension, arrow 2, to attaching plates that are welded to each wing frame. Fasten with four (4) 3/4" x 2-1/2" (19mm x 254mm) hex bolts c/w nuts and lockwashers. Tighten bolts.

NOTE: Use necessary 1" x 1" (25.4mm x 25.4mm) shim plates to align and level each beam extension. See FIG. 20, Detail A.

	<p>CAUTION To prevent serious injury or death from falling frames, always place adequate supports under all three frames.</p>
---	--

38. Installing front wing supports - Wide wing discs only - See. FIG. 28.

NOTE: See specifications to determine if your disc uses a wide wing frame.

Attach one (1) front wing support, arrow 5, to each wing frame with two (2) 3/4" x 4" x 5-5/8" (19.1mm x 101.6mm x 142.9mm) U-bolts c/w nuts and lockwashers. Locate attaching plate approximately 10" (254mm) from inside of front cross tube, arrow 6. Tighten U-bolts.

FIG. 29

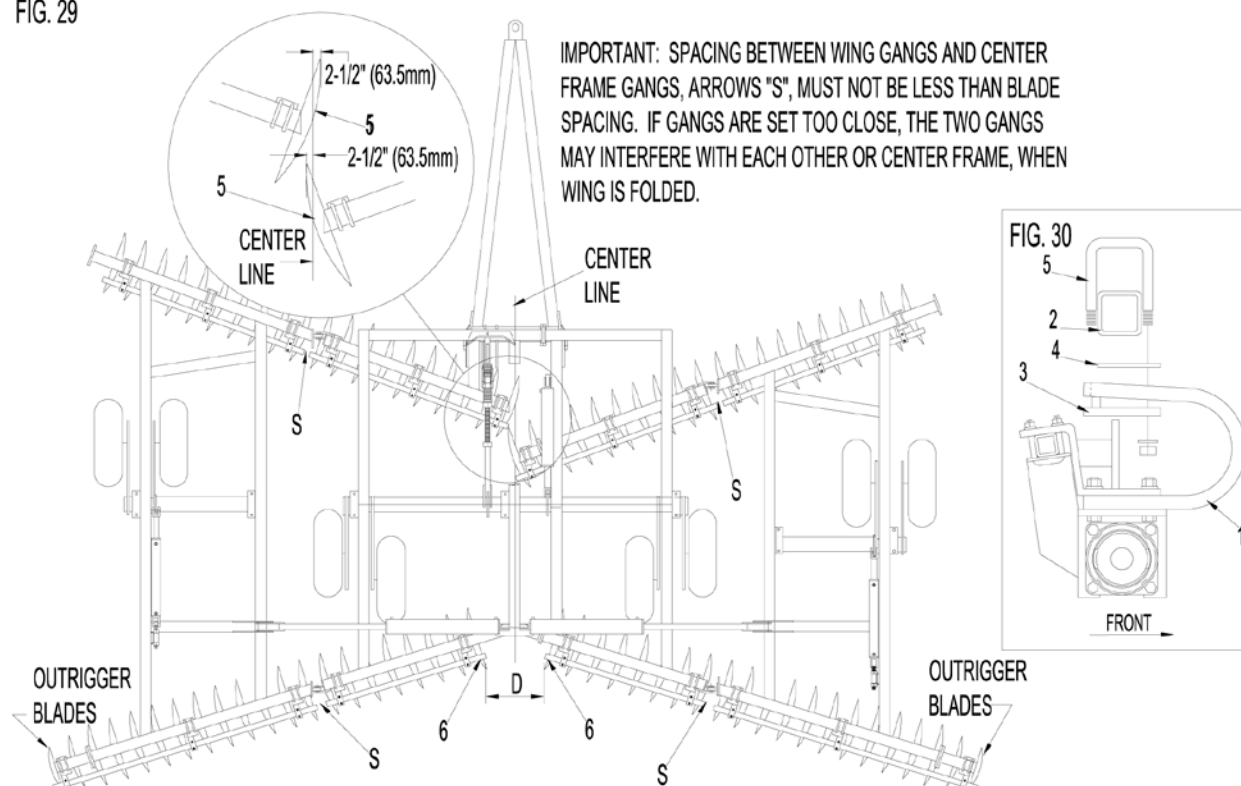

39. Attaching gang assemblies - See FIG. 29

NOTE: See gang patterns to determine gang position for your disc.

A - Rear gangs - Roll rear gang assemblies in place under rear gang beams of main and wing frames. Position rear gangs so that the scrapers are at the rear. The gang assemblies with outrigger blades (small diameter blades) must be positioned at the outside. See FIG. 29 for the direction rear gangs face. Attach bearing hangers to gang beams with two (2) U-bolts per bearing hanger. Leave U-bolts loose. If disc is equipped with optional stone flex bearing hangers, see Step "C" below to attach hangers.

B - Front gangs - Roll front gang assemblies in place under front gang beams of main and wing frames. Position gang assemblies so that the scrapers are at the rear. See FIG. 29 for the direction the front gangs face. Attach bearing hangers to the gang beams with two (2) U-bolts per bearing hanger. Leave U-bolts loose. If disc is equipped with optional stone flex bearing hangers, see Step "C" below to attach hangers.

C - See FIG. 30. Optional stone flex bearing hanger - Fasten each stone flex hanger assembly, arrow 1, to bottom of gang beam, arrow 2, with one (1) backing plate, arrow 3, two (2) 3/4" x 4" x 7" (19 x 102 x 178mm) U-bolts and one (1) bearing plate, arrow 4. The bearing plate is placed between bottom of gang beam and top of spring shank. When installing U-bolts, be sure rear leg of each U-bolt is installed through a hole in bearing plate. Be sure the pin on backing plate, arrow 3, is inserted in slot of shank.

NOTE: Keep bearing hanger U-Bolts tight.

D - See FIG. 29. Set front center frame gangs, so that the leading edge of inside blade, arrow 5, on rear gang is 2-1/2" (63.5mm) past center of disc frame (center line of center frame is shown in FIG. 29).

E - See FIG. 29. Set rear center frame gangs, arrow 6, so that the distance between the rear edge of the two inside blades, dimension "D", is equal to 2" less than diameter of blade. For example, if your disc is equipped with 24" diameter blades, dimension "D" would be set at 22". Be sure rear gangs are centered on frame.

F - See FIG. 29. Adjust spacing between each individual gang assembly. This spacing should be the same as the blade spacing of the gang assemblies.

NOTE: Space between wing gangs and center frame gangs must not be less than blade spacing. If gangs are set too close the two gangs may interfere with each other when wings are folded.

G - Before tightening bearing hanger U-Bolts, loosen U-bolts which fasten scraper bar bearing hanger. Then check each bearing hanger to make sure hanger is sitting square under gang beam. Also, be sure hanger is not turned to one side. Tighten U-Bolts. If your disc is equipped with solid bearing hanger, tighten U-Bolts to 150 ft. lbs (203.25 N.m). If your disc is equipped with stone flex hangers, tighten U-bolts to 260 ft. lbs (352.3 N.m).

NOTE: If bearing hangers are not sitting square before tightening U-Bolts, thrust will be built into the bearings and the life of the bearing will be shortened.

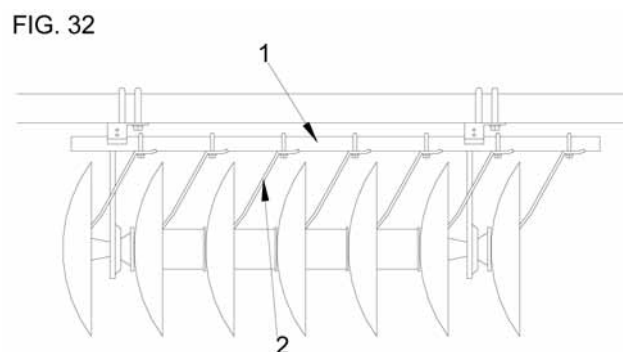
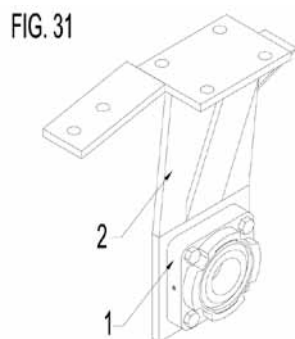

40. See FIG. 31. Loosen all the bolts, arrow 1, which fastens the bearings to the hangers, arrow 2. Then turn the disc blades to allow the bearings to align themselves. Next, tighten all the bolts. This will ensure proper bearing alignment, increasing bearing life.

41. **NOTE:** When raising wings for transport for first time after adjusting gangs, raise wings slowly making sure wing gangs clear center frame gangs.
42. See FIG. 32. Adjust scraper bar, arrow 1, and scrapers, arrow 2, of each gang so that each scraper blade is in contact with disc blade. Tighten U-Bolts.

NOTE: Disc will require less horse power to pull if scrapers are adjusted properly.

	<p><u>CAUTION</u> When attaching gang assemblies, wear protective gloves to help prevent injury from cutting edges of blades.</p>
---	--

FIG. 33



43. See FIG. 33. Mount the SMV bracket, arrow 1, to the main frame's rear inside bearing hanger on the L.H. rear gang. Secure to the top of the scraper bar support with the same U-Bolt used to fasten the scraper bar to the bearing hanger. Tighten nut.

44. See FIG. 34. Level wing frame with main frame as follows:

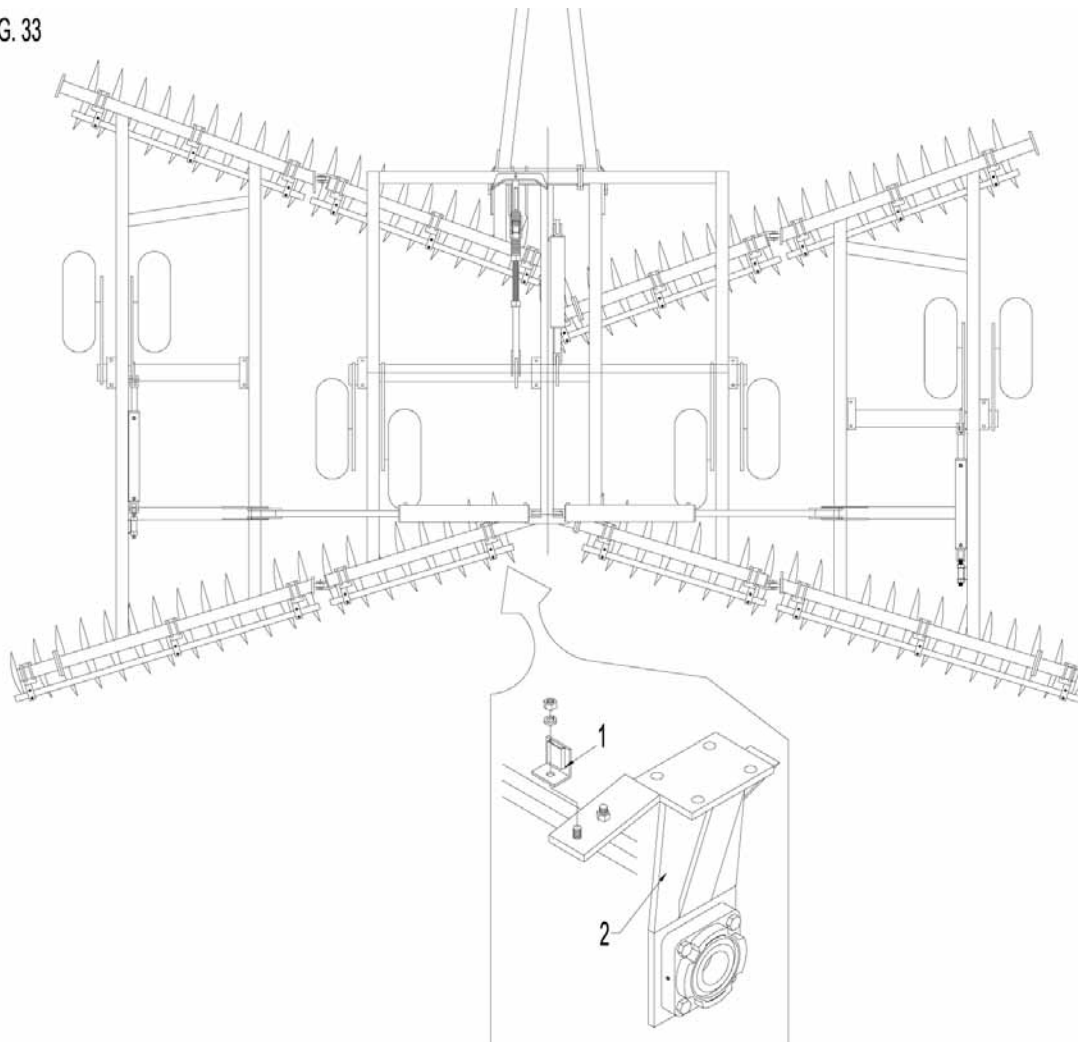
1 - Raise disc by extending rockshaft cylinder. Be sure wing rockshaft cylinders are fully extended.

2 - Check the distance the spindle mounting tube, arrow 1, (welded to bottom of rockshaft wheel leg) is from the bottom of each wing frame. This distance should be 25" (635mm).

3 - If spindle mounting tube location is not correct, adjust length of wing cylinder, I-bolt, arrow 2.

4 - After adjustment is complete, lock I-Bolt by tightening front nut, arrow 3, against I-Bolt holder.

NOTE: The above wheel leg setting is an initial setting only. If wing gangs do not cut at same depth as the main frame gangs, further wing cylinder adjustment will be required.

NOTE: Be sure axis of barrel end pin is horizontal and cylinder points are facing up. If cylinder and I-Bolt are not positioned properly, cylinder will not be free to pivot when activated causing serious damage.

FIG. 34

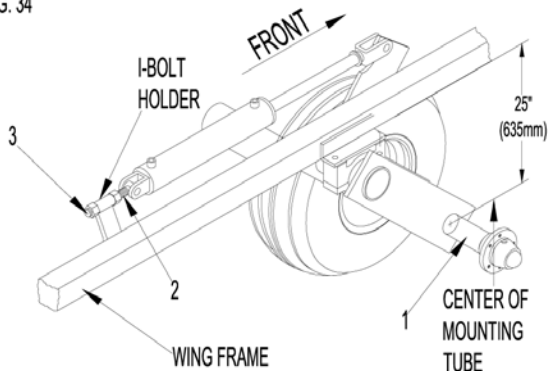
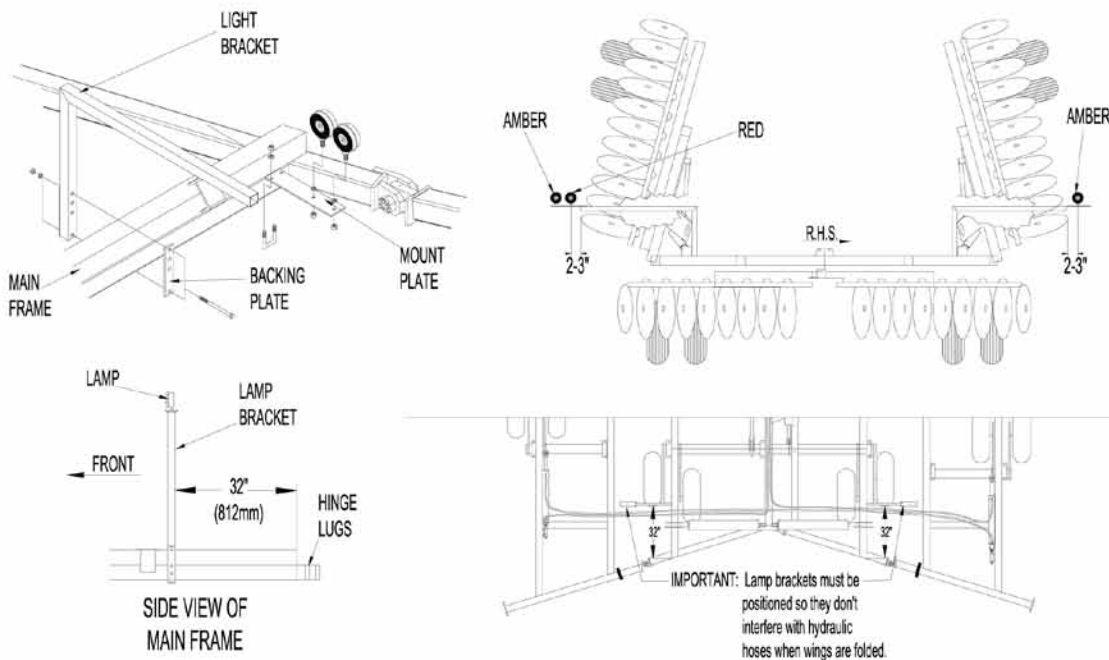

FIG. 35



45. Warning light kit (optional) - Mount instructions - See FIG. 35.

**WARNING**

Do not stand under wings when working on disc. If hydraulic system failed or if hydraulic lever was accidentally operated, wings may fall resulting in serious injury or death to person(s) near disc.

A - With disc folded, install one lamp support bracket on each side of main frame. Locate each bracket on inside of double 4" x 4" (101.6mm x 101.6mm) tubes 32" (812mm) from rear of main frame. Fasten each support with two (2) 1/2" x 7-1/2" (12.7mm x 190.5mm) hex bolts c/w nuts and lockwashers and one (1) backing plate.

NOTE: Lamp brackets must be positioned as shown in ILL. 35 so they don't interfere with the hydraulic hoses when wings are folded.

B - Fasten one (1) mount plate to top of each lamp support bracket with one (1) 1/2" x 2" x 3" (12.7mm x 50.8mm x 76.2mm) U-Bolt c/w nuts and lockwasher. Do not tighten U-Bolt at this time.

C - Fasten one (1) amber lamp and one (1) red lamp to the L.H. mount plate. Position amber and red lamps so they face the rear with the amber lamp on the outside. Install lamps through 3/4" (19.1mm) holes in mount plate. Secure with nuts. Leave nuts loose on amber lamp so ring connector on wiring can be installed later.

D - Fasten one (1) amber lamp to R.H. mount plate. Position so amber lamp faces rear. Install lamp through 3/4" (19.1mm) hole in mount plate. Secure with nuts.

NOTE: Paragraphs "C" and "D" and FIG. 35 describe and show lamp positions for North American public roads. For other countries such as Australia, check local laws and regulations for required warning light mounting positions.

E - Loosen U-Bolt of each mount plate, then with disc folded for transport, position L.H. lamps so center of red lamp is 2 to 3" (50.8mm to 76.2mm) outside widest point of machine. Position R.H. amber lamp so it is 2 to 3" (50.8mm to 76.2mm) outside widest point of machine. Warning lamps must be visible from the front and the rear of the machine. Tighten mount plate U-Bolts.

**CAUTION**

When transporting disc over public roads, use the emblem and warning light for protection of tractor and other motor vehicle operators. Check local laws for width and height maximums.

F - Install electrical wiring as follows:

F1 - See Fig. 36 - Run four (4) wire cables (brown, white, yellow, and green) from tractor socket receptacle to rear of disc. Split off green wire and run it to the R.H. amber lamp. Next run white wire to amber lamp on L.H. side, then run yellow wire to L.H. amber lamp and run brown wire to red lamp on L.H. side. Strip wires and fasten ring connector to each wire. Install ring connector of each wire to threaded stem of each lamp.

F2 - Next, disassemble male plug, then insert all wires through spring end of male plug. Strip wires and insert each wire into specific terminal of outer half of male plug. Use FIG. 36 to match wire color to proper terminal number. Reassemble both halves of male plug.

F3 - Insert male plug into tractor's socket receptacle. Activate warning light switch and check if all lamps are flashing.

F4 - NOTE: Run wires along frame member. Do not run wires across open spaces. Wires that are run across open space will be damaged during discing operations by people working on the disc.

F5 - Install a 1/2" I.D. x 8' (12.7mm x 2.4m) long plastic loom over wires that run from male plug shown in FIG. 36. The plastic loom is installed by pushing the wires into the opening that runs the length of the loom.

FIG 36

(A): Power Source (Tractor)

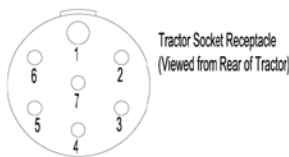

IMPORTANT: Ensure tractor receptacle (socket) is configured as shown at left prior to installing Safety Light Kit.

- #1 - White - Ground
- #2 - Black
- #3 - Yellow - L.H. Flashing
- #4 - Red
- #5 - Green - R.H. Flashing
- #6 - Brown
- #7 - Blue

NOTE: Wiring diagrams shown follow standardized industry wiring connections used in the manufacture of agricultural machinery.

NOTE: White wire is common ground

(B): Basic Light Kit
- For 1st Implement

Crimp Ring Connector (yellow) on White wire (Ground) and install on stem of Amber Light

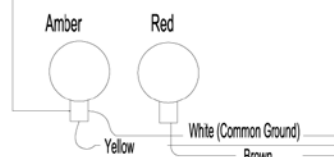

AUSTRALIAN NOTE: TO INSTALL RED LAMP ON RIGHT SIDE SPLIT OFF BROWN & GREEN WIRES TOGETHER.

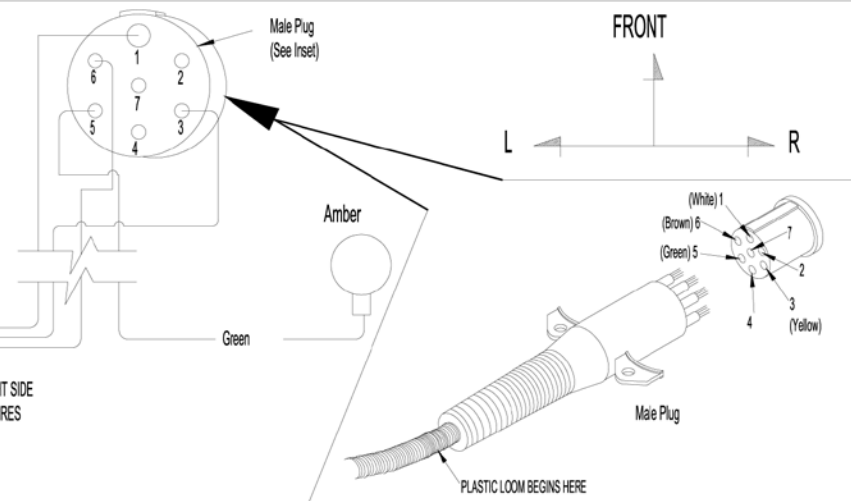

Components: Basic Light Kit

- 1 - 7 pin male plug c/w 55ft. (13.7m) 14/4" rib wire
- 3 - Nylon connectors (closed end)
- 2 - Lamps - amber both sides
- 10 - Cable ties

- 1- 8' (24.4m) 1/2" (12.7mm) plastic loom
- 1- Ground Connector - ring type (7/16" - 1/2") (11.1mm - 12.7mm)
- 1- Lamp - red one side

FIG 37

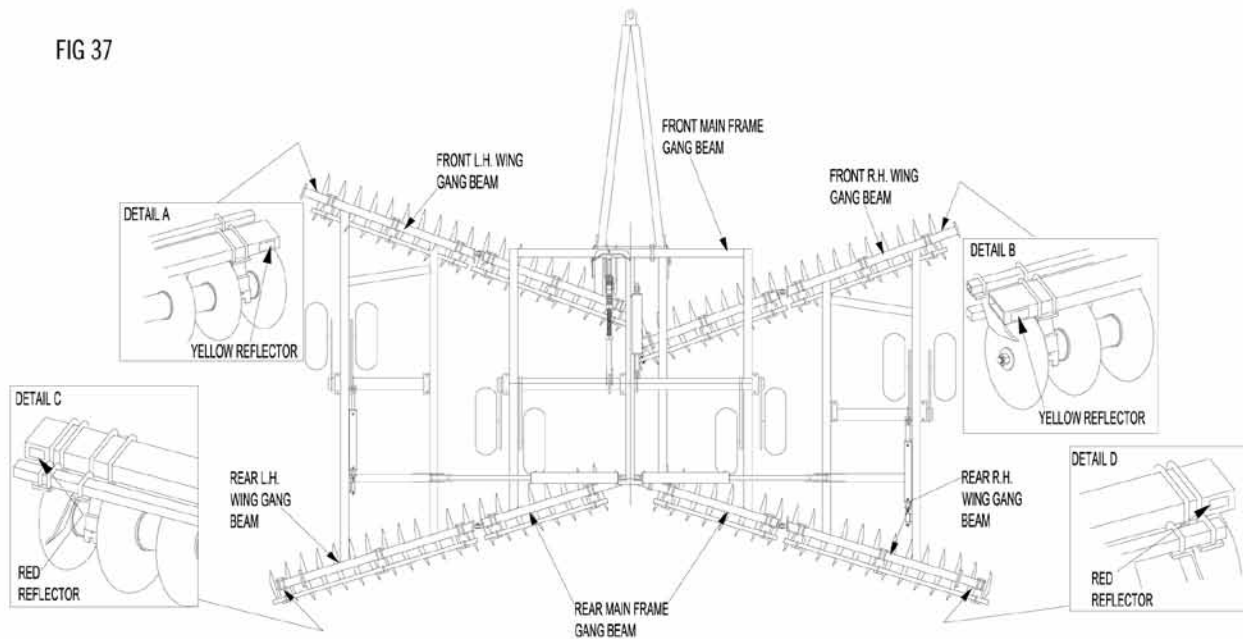

46. Reflector decal installation - See FIG. 37.

NOTE: Before installing decals, clean the area they will be placed on.

A - Place one (1) 2" x 9" (50.8mm x 228.6mm) red reflector decal on rear side of each rear gang beam. Locate decals approximately 1" (25.4mm) from end of gang beam. See detail "C" and "D".

B - Place one 2" x 9" (50.8mm x 228.6mm) yellow reflector decal on front side of each front gang beam. Locate decals approximately 1" (25.4mm) from end of gang beam. See detail "A" and "B".

Wing Beam Extensions

Model	Front Extension Length	Rear Extension Length	Front Extension Length	Rear Extension Length
	8" Spacing		9" Spacing	
82B	-	12" Solid	-	-
94B	12" Solid	42" Solid	-	-
106B	18" Solid	42" Solid	-	-
114B	36" Solid	60" Solid	-	-
122B	50" Solid	78" Solid		
74B	-	-	-	16" Solid
86B	-	-	16" Solid	42" Solid
94B	-	-	16" Solid	42" Solid
102B	-	-	36" Solid	60" Solid
106B	-	-	42" Solid	72" Solid

Gang Pattern - 8" Spacing - 82 Blades/22 Bearings - Front

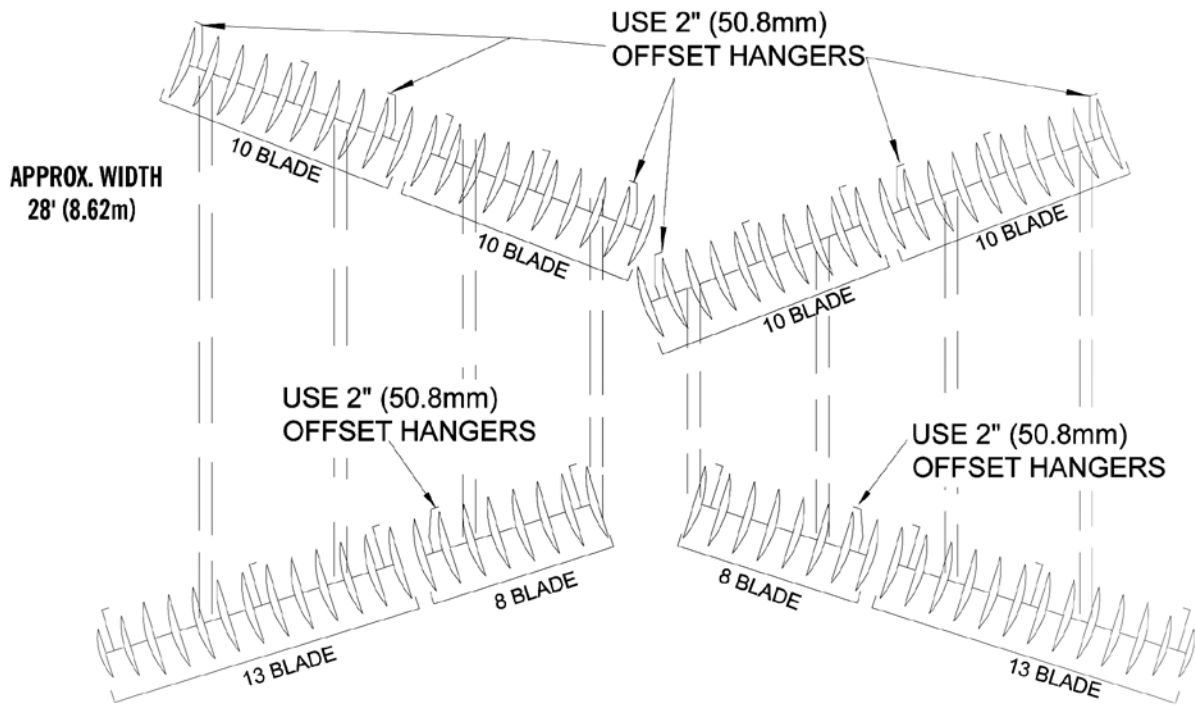

Gang Pattern - 8" Spacing - 94 Blades/24 Bearings - Front

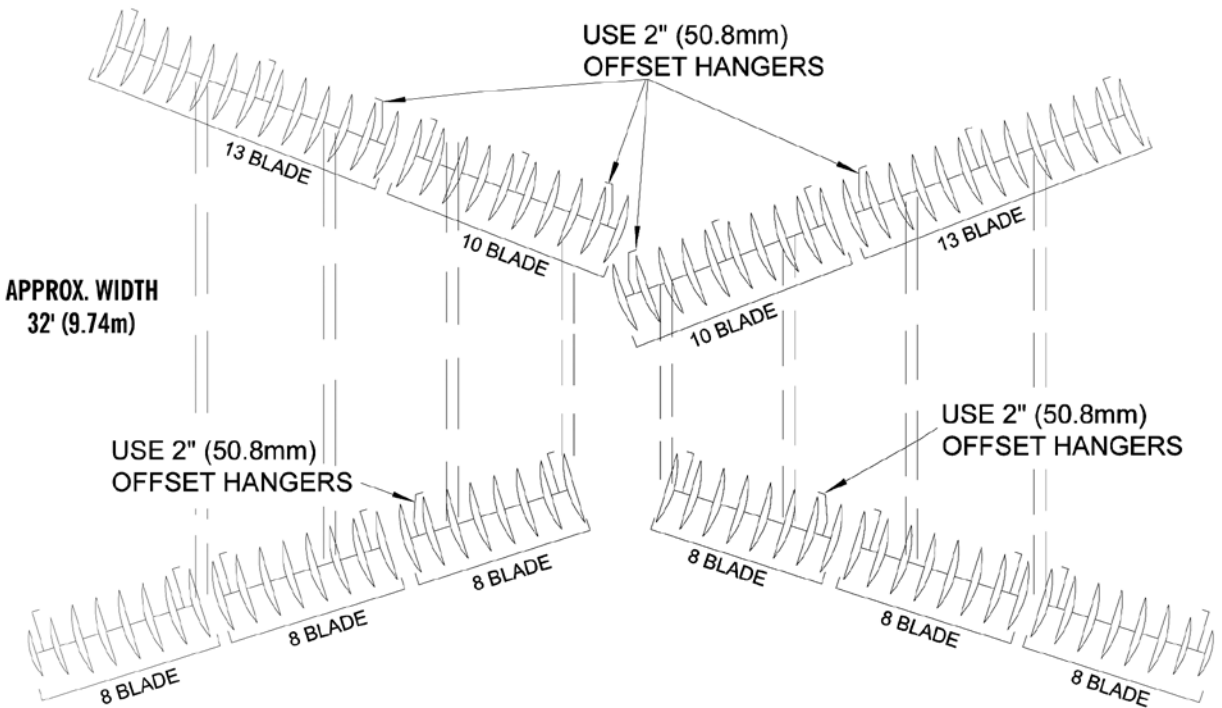

Gang Pattern - 8" Spacing - 106 Blades/30 Bearings - Front

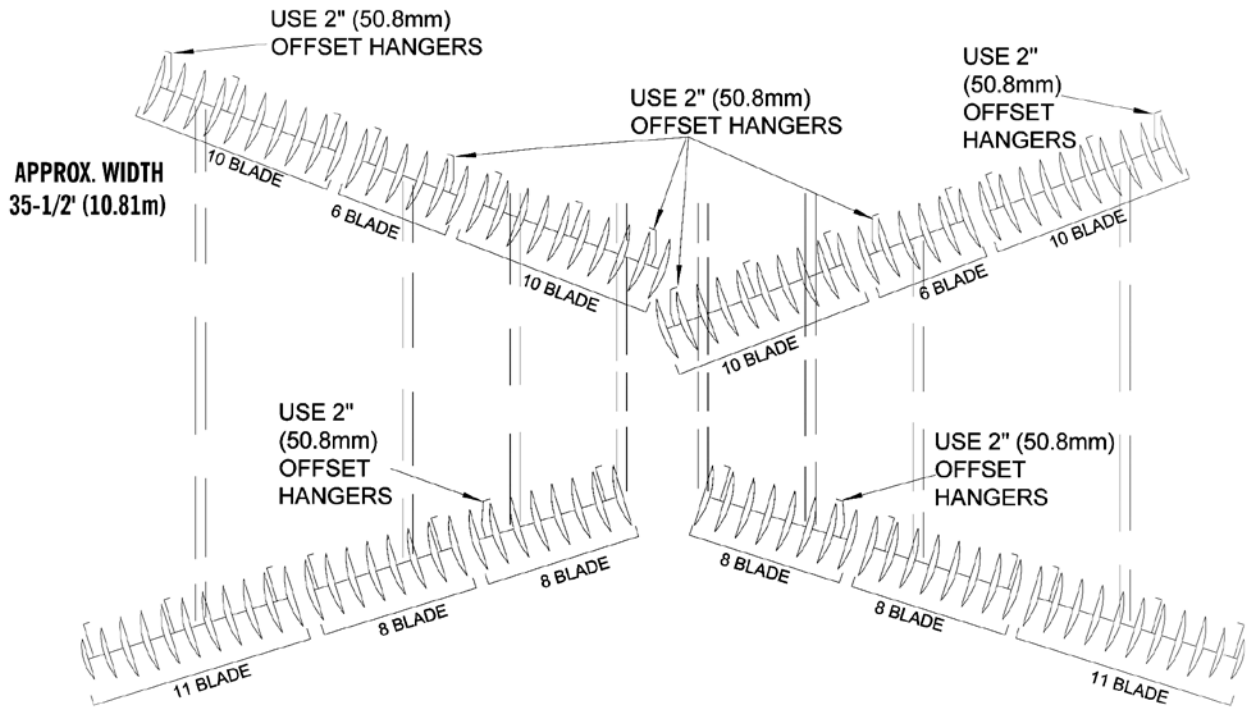

Gang Pattern - 8" Spacing - 114 Blades/30 Bearings - Front

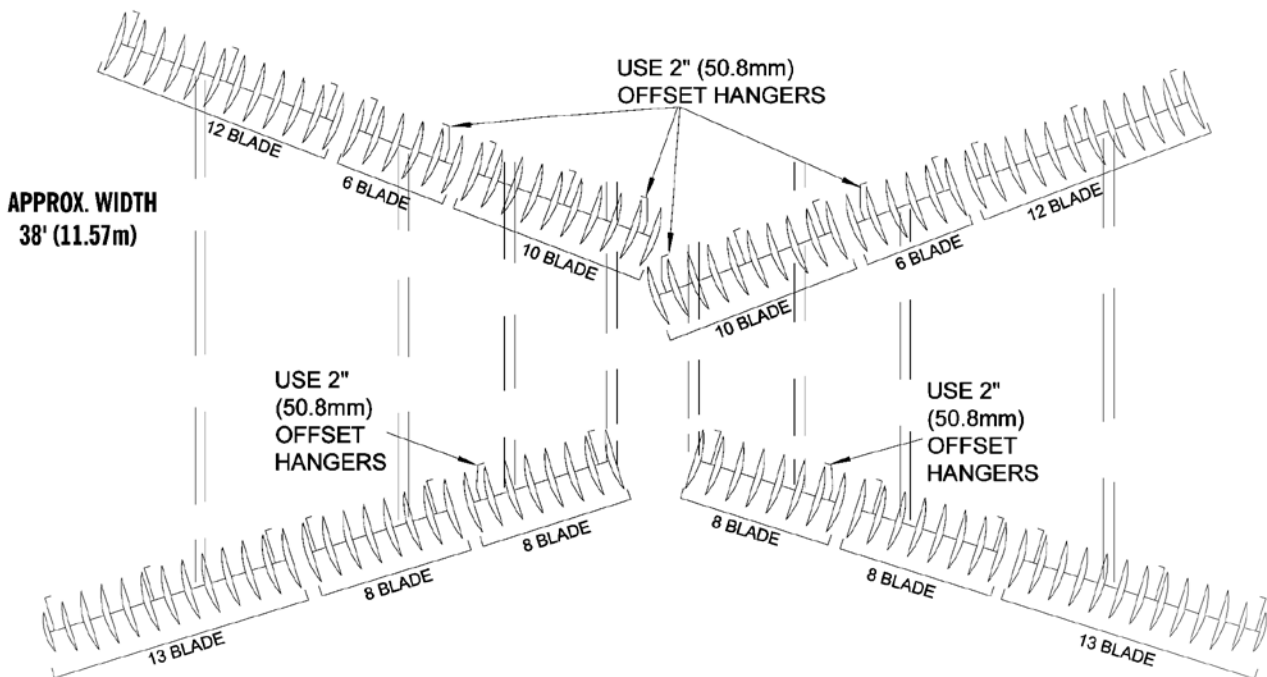

Gang Pattern - 8" Spacing - 122 Blades/34 Bearings - Front

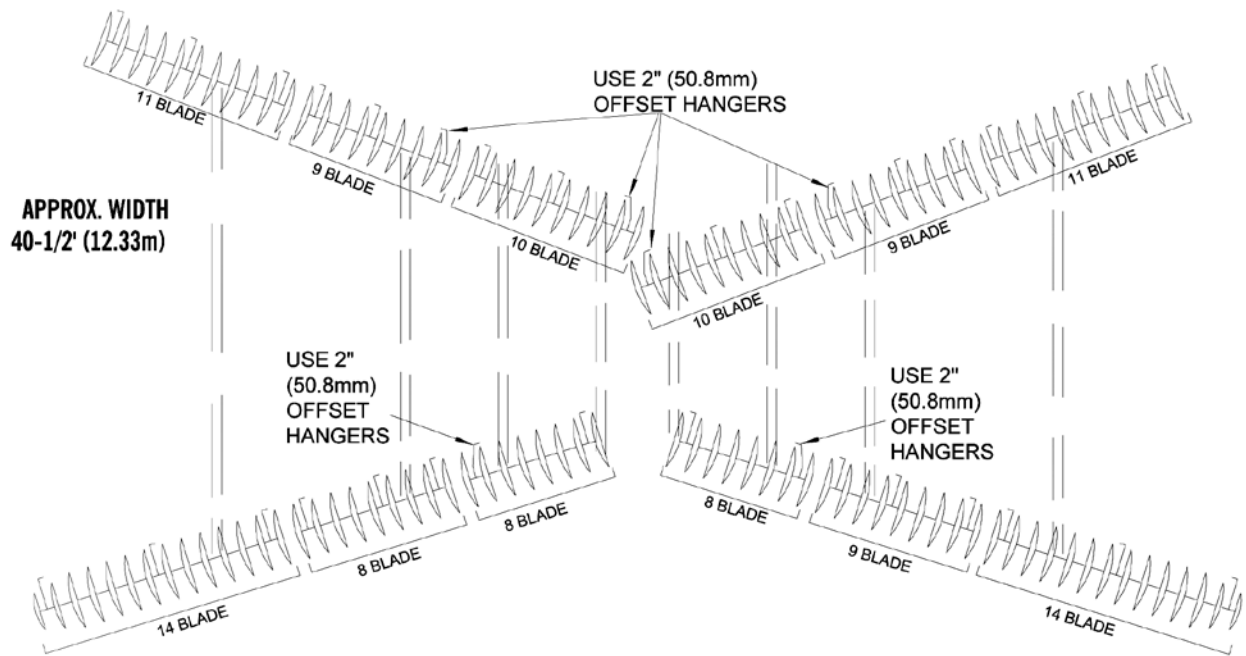

Gang Pattern - 9" Spacing - 74 Blades/22 Bearings - Front

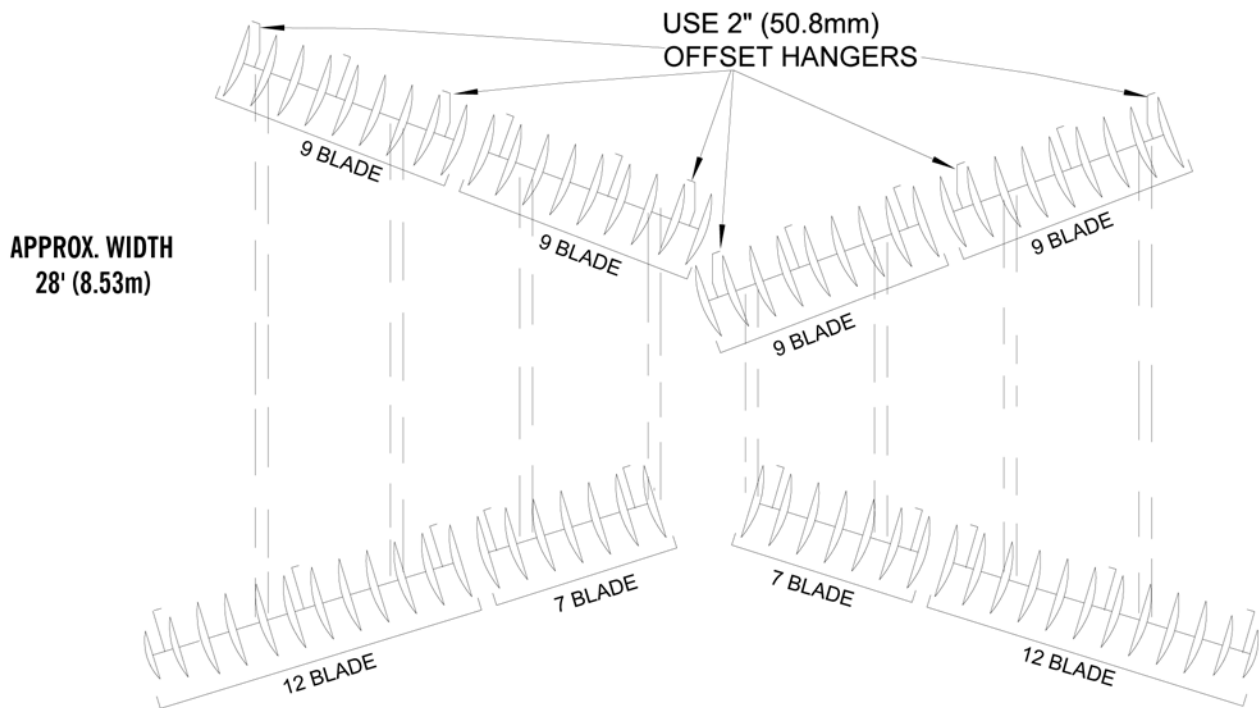

Gang Pattern - 9" Spacing - 82 Blades/22 Bearings - Front

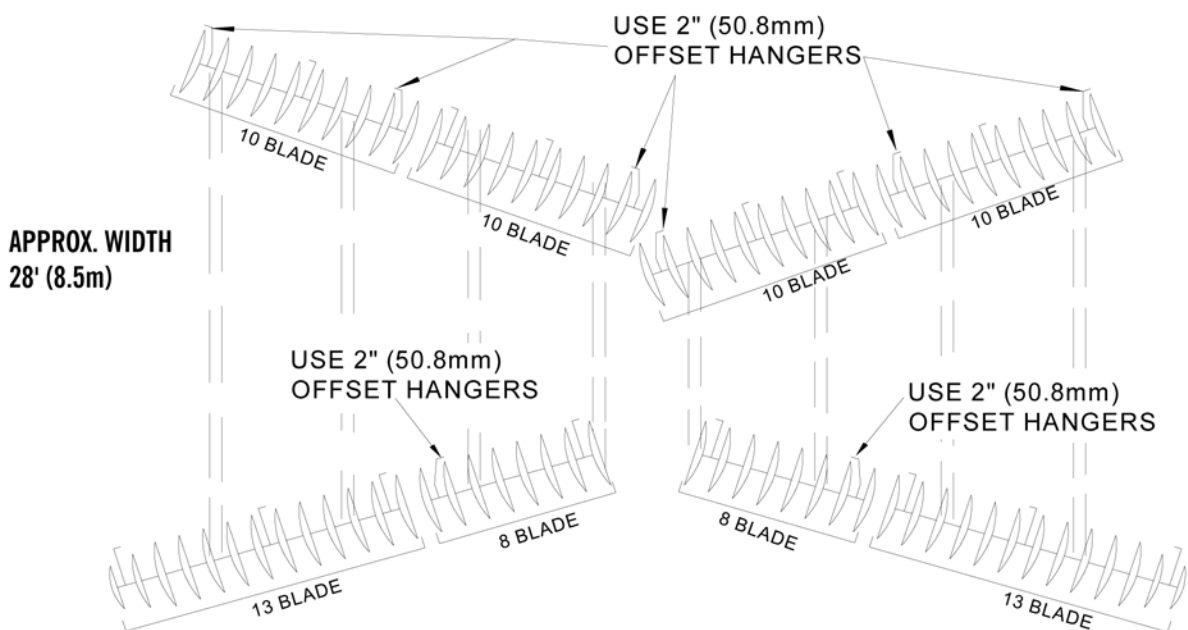

Gang Pattern - 9" Spacing - 86 Blades/24 Bearings - Front

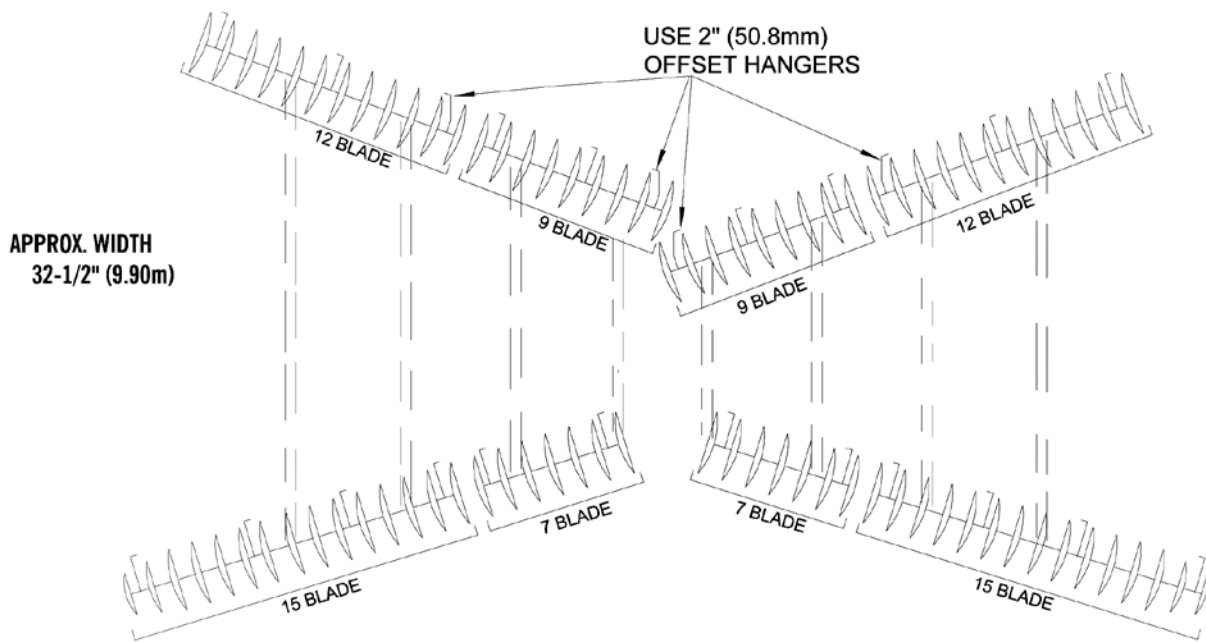

Gang Pattern - 9" Spacing - 94 Blades/28 Bearings - Front

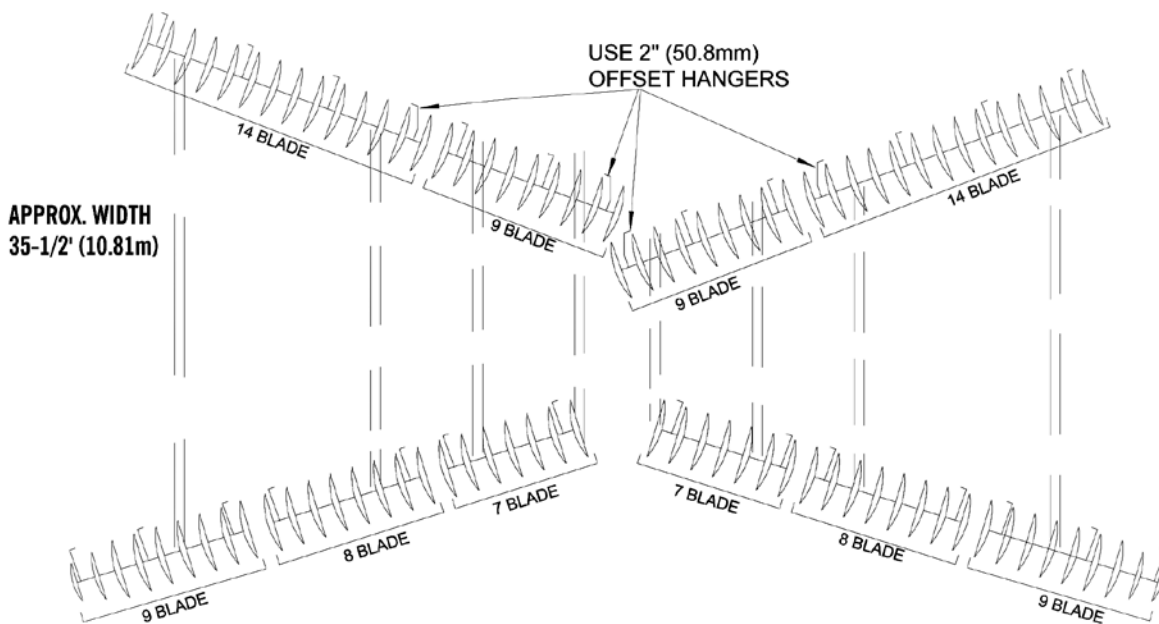

Gang Pattern - 9" Spacing - 102 Blades/30 Bearings - Front

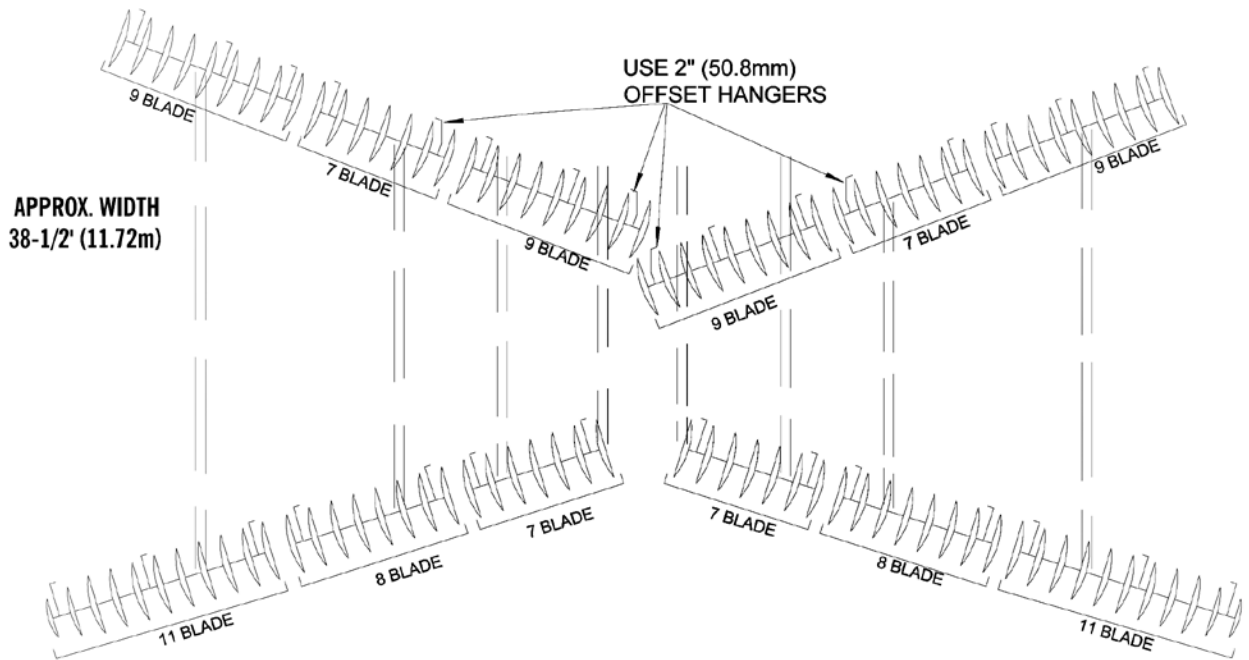

Gang Pattern - 9" Spacing - 106 Blades/30 Bearings - Front

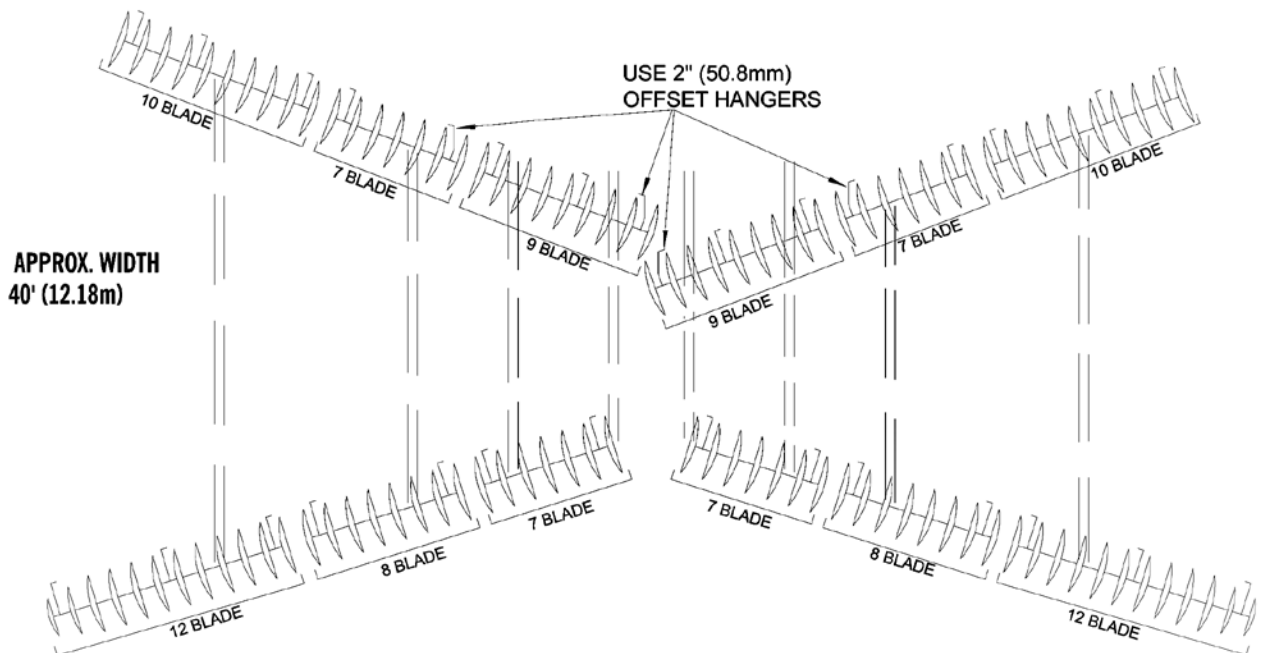

Operation Instructions

1. Before operating disc, refer to safety precautions. Review disc safety items applicable to road transport and field operation of disc.
2. **NOTE:** When lowering wing to field position, be sure wing lift cylinders are fully extended. After wing tires have hit the ground continue to hold hydraulic lever. There will be a short pause before cylinders fully extend. If cylinders are not fully extended, the wing will hang on cylinders and will not flex down.



CAUTION

Never stand between the tractor and disc when hitching disc to the tractor unless all tractor controls are in neutral and the brake is set. The tractor could roll backwards which could result in serious injury or death to you or the persons nearby.

3. Do not make sharp turns with the disc in ground. Sharp turns put excess pressure on the gangs.

It is advisable to always lift machine out of ground for making sharp turns. Excessive side thrust is applied to bearings and machine if disc is turned while it is in the ground.

4. For best performance, the tractor drawbar should be pinned at center of tractor.
5. Ensure disc is level fore and aft and side to side and cutting depth is properly adjusted.
6. See FIG. 1. When transporting disc, always place hydraulic lockup valves in closed position. Lockup valves are located at the front end of centre frame.

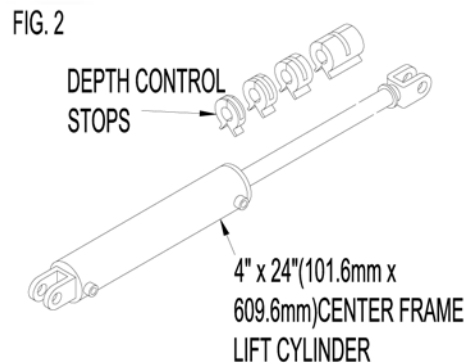
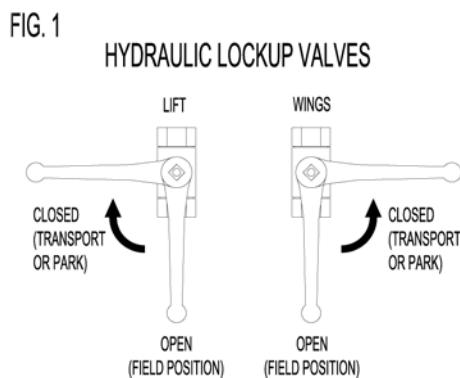

CAUTION

When transporting disc always place both hydraulic lockup valves in "closed position". If hydraulic lever was accidentally operated the disc could drop or wings could fall causing serious injury or death to operator or person(s) nearby.

7. See FIG. 2. When transporting disc always place the complete depth control package 17" (431.80 mm) long on shaft of 4" x 24" (102 mm x 610 mm) centre frame lift cylinder.

**WARNING**

When transporting disc always install the complete package of depth control stops 17" (432 mm) long on shaft of center frame cylinder. If any component of hydraulic system failed disc could drop causing serious injury or death to operator or persons nearby.

8. **NOTE:** When transporting disc, do not exceed speed of 10 mph (16 km/h).
9. **NOTE:** Do not operate disc in field with wings folded in transport position. Severe damage will occur when discing with wings folded.
10. **NOTE:** Do not disc with front gangs cutting deeper than rear gangs. Disc must be level. If front gangs are lower, excessive strain will be placed on blades, gang bearings and frame hitch, which could lead to premature parts failure, especially outside blades of front gangs.
11. **NOTE:** When disc is parked with blades resting on frozen ground, do not attempt to lift disc out of frozen ground by lowering transport wheels. Lifting disc out of frozen ground with transport wheels may cause serious damage to disc components. Damage will most likely occur to main lift cylinders and rockshaft cylinder arms.

Do not park disc with blades on ground that may freeze. Leave disc parked on transport wheels.

12. To avoid serious damage to hitch jack, be sure jack is locked in horizontal position and crank of jack is not hanging below hitch when disc is in motion.
13. See FIG. 3. Attach a safety chain to the tractor drawbar and to the disc's hitch before transporting the disc. Use a chain with strength rating greater than the gross weight of disc. (Safety chain available as an option).

**DANGER**

When transporting a disc, be sure to attach a safety chain to tractor drawbar and disc hitch. The safety chain will help control disc should it accidentally separate from the drawbar. Use a chain with a strength rating greater than the gross weight of the towed machine. Serious damage, injury or death could result from the disc separating from the tractor drawbar.

**DANGER**

See FIG. 4. Do not stand under the wing(s) while it is being raised or lowered. If any component of the hydraulic system failed or if the hydraulic lever was accidentally operated, wing could fall causing serious injury or death.

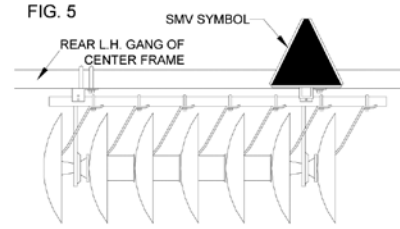
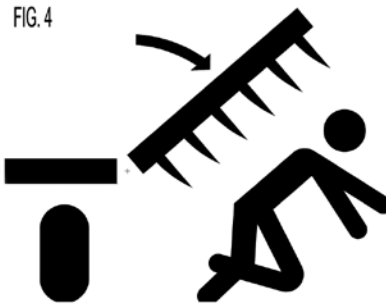
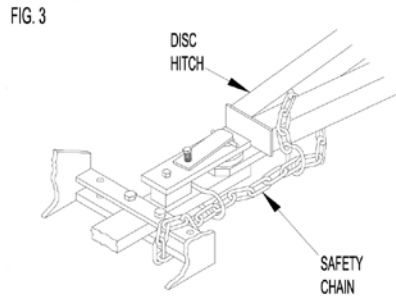



14. See FIG. 5. Install the "SMV" emblem in the "SMV" bracket bolted to rear L.H. gang of centre frame.

	<p><u>CAUTION</u></p>	<p>Use the SMV emblem and warning lights for the protection of tractor and other motor vehicle operators when transporting the cultivator over public roads. Check local laws regarding transporting regulations.</p>
---	------------------------------	---

	<p><u>CAUTION</u></p>	<p>Disc may fall rearward suddenly and hitch may rise abruptly if disc is unpinned from tractor when disc is fully raised and wings unfolded.</p>
--	------------------------------	---

	<p><u>CAUTION</u></p>	<p>Always use caution and ensure other person(s) are not standing near disc when unhitching from tractor. Always use caution and ensure other person(s) are not standing near disc when unhitching from tractor.</p>
---	------------------------------	--

	<p><u>CAUTION</u></p>	<p>When trailing the disc over public roads, use the SMV emblem and warning lights for protection of tractor and other motor vehicle operators. Check local laws for width and weight maximums and height maximums.</p>
---	------------------------------	---

	<p><u>CAUTION</u></p>	<p>Do not exceed 10mph (16km/h) when transporting disc on smooth roads, reduce speed when transporting on rough roads. Excessive speed could cause loss of tractor control and damage to disc and tractor. Do not transport disc with any other vehicle except tractor.</p>
---	------------------------------	---



DANGER

When transporting disc with wings raised, be sure there is sufficient clearance under all powerlines and other overhead obstructions. Serious injury or death can result from contact with electrical lines. Use care to avoid contact with electrical lines when moving or operating disc. Models equipped with folding gang beams must have these beams folded to give minimum transport height.



WARNING

When transporting disc, always place hydraulic lockup valves in "closed position". If the hydraulic lever was accidentally operated, the disc could drop or wings could fall causing injury to operator and person(s) nearby.

15. Rephasing rockshaft cylinders - Periodically, the hydraulic lift cylinders on wing frame will not be synchronized with center frame cylinder. This will cause uneven cutting depth. If this happens it will be necessary to rephase the lift cylinders. Rephasing is done by lifting disc completely out of the ground and holding the hydraulic control lever until all (3) three rockshaft cylinders are fully extended.



WARNING

Never allow anyone to ride on drawbar of the tractor or on the disc. The person riding may fall and be seriously injured.



WARNING

Lower the disc to the ground when servicing or making adjustments. If the disc must be serviced or adjusted in the raised position, place block under frame. Do not rely on hydraulic lockup valves as a safety device. If the hydraulic system failed, or if the hydraulic lever was accidentally operated, the disc could drop.



CAUTION

When operating on hillsides, use extra care. Tractor may tip sideways if it strikes a hole, ditch or other irregularities.

16. **NOTE:** When parking disc always release pressure in hydraulic cylinders. Serious damage could occur to hydraulic cylinder if thermal expansion of hydraulic oil takes place due to warmer weather or if disc is stored in heated building.
17. **NOTE:** When parking disc always place both hydraulic lockup valves in "closed position"

18. In discing conditions where extreme wing flexibility is required, remove cylinder pin from shaft end of each wing lift cylinder and retract cylinders.

When reattaching shaft end of wing lift cylinders to wing frame, be sure cylinder shaft does not strike cylinder lug on wing frame. Serious damage may occur to cylinder if cylinder shaft strikes cylinder lug. Before extending cylinder shafts block up cylinder so that cylinder shaft passes over cylinder lugs.

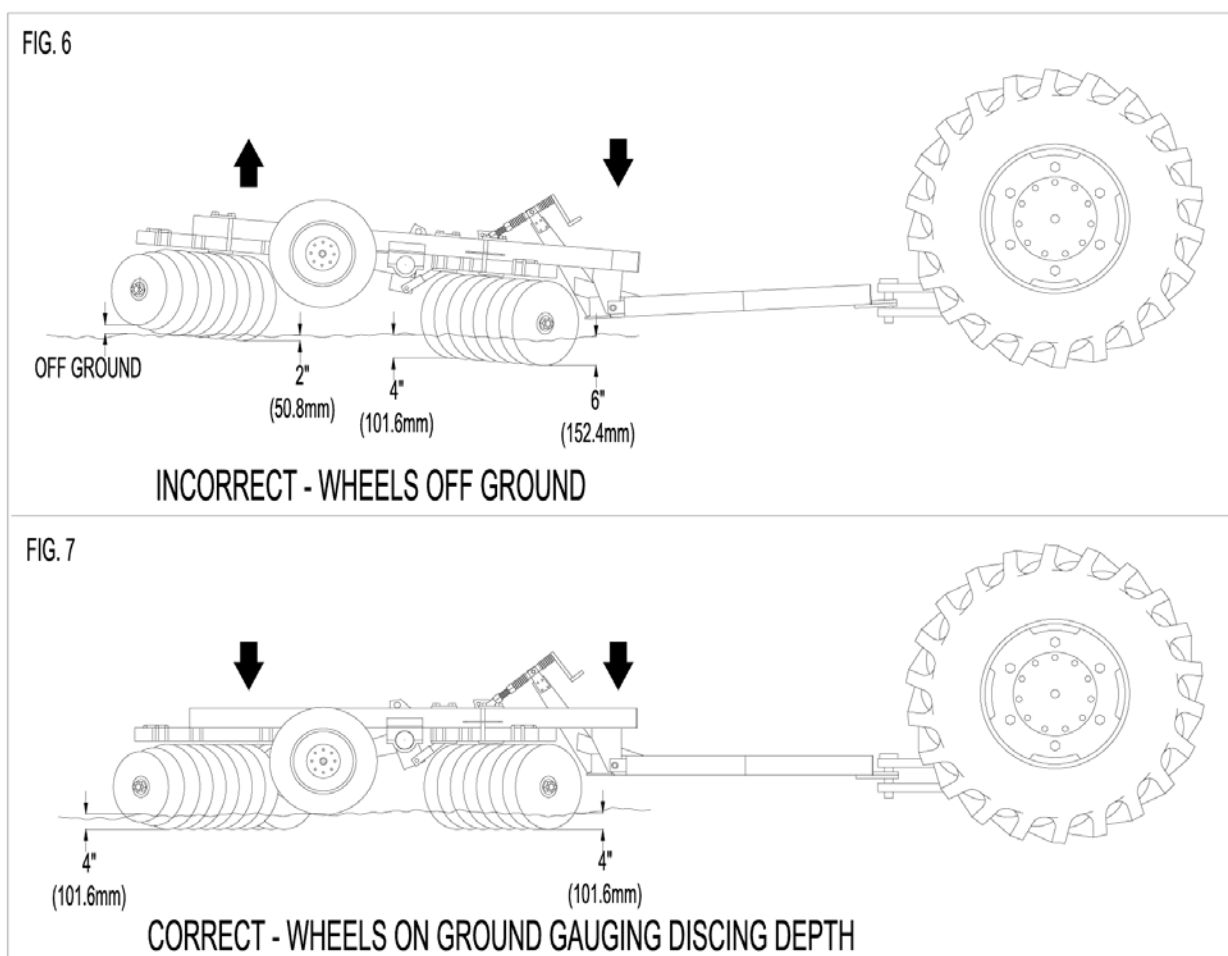

19. To keep disc level transport wheels must be riding on ground gauging desired discing depth, as shown in Fig. 7.

If conditions are such that disc can not penetrate to maximum depth, do not raise transport wheels off ground as shown in Fig. 6. Raised transport wheels may cause front of disc to drop causing front gangs to cut deeper than rear gangs.

Front of disc may drop because rockshaft and hitch levelling arm is linked. As the wheels are raised, the hitch levelling arm is pulled back allowing hitch to float. If hitch is allowed to float it will not support front of disc allowing front gang to drop.

With front of disc lower than the rear, the front outside blades will cut much deeper than the front inside blades. This means that more of the disc's weight is placed on the front outside blades, forcing them deeper into the ground.

Uneven and deep front gang penetration in tough conditions will place excessive strain on blades, gang bearings, frame and hitch, and will lead to a premature failure of parts especially outside blades and bearings of front gangs.

NOTE: Operating disc with transport wheels off ground will cause uneven discing job and place undue strain on machine which could lead to parts failure. Always operate disc with transport wheels on ground even if soil conditions will not allow disc to penetrate to maximum depth.

Adjustments

1. Lateral adjustment of the front and rear gangs

A - Front gangs - See FIG. 8. Loosen bearing hanger U-Bolts and adjust front gangs so that leading edge of inside blades are, arrow 1, approximately 2-1/2" (63.5 mm) past centre of disc. The centre of disc is shown in FIG. 8. If the above adjustment is made correctly, the front gang will not leave any unbroken ground at centre of disc.

B - Rear gangs - See FIG. 9. To adjust rear gangs, loosen bearing hanger U-Bolts.

The opening between the rear gang dimensions "D" must be set at a distance that will allow furrow left by the front gangs to be filled evenly. The distance the rear gangs are set apart is determined by the discing speed, discing depth, gang angle and soil conditions. If the rear gangs are set too close together, the rear gangs will leave a ridge at centre. If rear gangs are set too far apart, the furrow at centre left by the front gangs will not be filled. Take note of the amount of soil the rear inside blades are packing up. It may be necessary to increase distance between rear gangs in order to collect enough soil to fill furrow. To start with this, distance should be set at 2" (50.8 mm) less than diameter of blades. For example, if your machine's equipped with 24" (610 mm) blades then the opening (Dimension "D") should be 22" (559 mm).

An increase in discing speed may required rear gangs to be set further apart. A decrease in discing speed may require rear gangs to be set closer together.

NOTE: Be sure the blade to blade distance between individual gangs are adjusted to match your disc's blade spacing.

C - When gang adjustments are complete, tighten all bearing hanger U-Bolts. Before tightening bearing hanger U-Bolts, check each hanger to make sure hanger is sitting square under gang beam. Also ensure hangers are not turned to one side. Tighten U-Bolt to 430 ft lbs (583.0 Nm).

2. **NOTE:** When raising wings for transport for the first time after adjusting gangs, raise wings slowly making sure wing gangs clear center frame gangs.

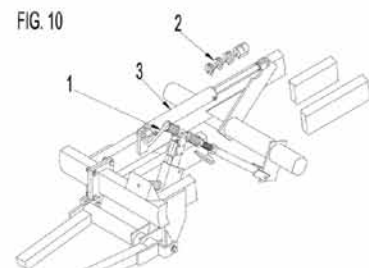
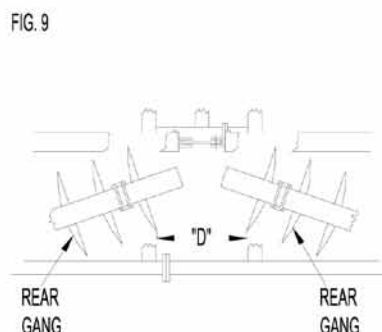
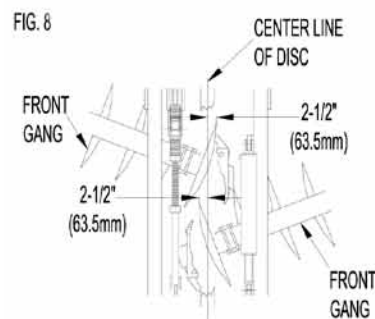

3. Levelling disc - Front to rear - See FIG. 10. When discing, the front and rear gangs should be cutting at same depth. The levelling crank, arrow 1, is used to level disc.

To lower front gangs - Turn crank, arrow 1, "IN" (clockwise)

To raise front gangs - Turn crank, arrow 1, "OUT" (counter clockwise)

NOTE: Always keep disc level from front to rear discing with front gangs lower than rear gangs will cause ridging at outside and may cause damage to disc components.

4. Setting discing depth - See FIG. 10. To set discing depth, lower disc into the ground while moving forward until disc reaches desired discing depth. Install the necessary depth control stops on centre frame lift cylinder shaft to maintain the desired cutting depth.

5. Levelling wing frames - See FIG. 11.

Before this adjustment is made, be sure centre frame is level from front to rear. After adjustments are complete tighten nuts on cylinder I-Bolt.

For even blade penetration, outside of wing frames must be level with centre frame or even 1/2" (12.7 mm) higher than centre frame.

To level wing frame with centre frame, adjust wing rockshaft cylinder I-Bolt, arrow 1. If outside of wing frame needs to be raised, loosen rear nut of I-Bolt and tighten front nut. This will lower the wheels raising outside of wing. If outside of wing frame needs to be lowered, loosen front nut of I-Bolt and tighten rear nut. This will raise the wheels allowing outside of wing lower. After adjustments are complete, lock I-Bolt by tightening rear nut against I-Bolt holder.

NOTE: Be sure axis of clevis pin is horizontal and cylinder ports are facing up. If cylinder and I-Bolt are not positioned properly, cylinder will not be free to pivot when activated, causing serious damage.

6. Remove ridge at center of disc - Make one or more of the following adjustments:
 - A - Level disc from front to rear using levelling crank.
 - B - Reduce discing speeds.
 - C - Increase distance between rear gangs.
7. Remove furrow at center of disc - Make one or more of the following adjustments:
 - A - Level disc from front to rear using levelling crank.
 - B - Increase discing speed.
 - C - Decrease distance between rear gangs.
8. Remove unbroken ground left by front gangs - Make the following adjustments:
 - A - Adjust leading edge of inside blade of each front gang so it is 2-1/2" (63.5mm) past centre of disc.
9. Reduce gang plugging - Make the following adjustment:
 - A - Adjust scrapers so they contact blades.

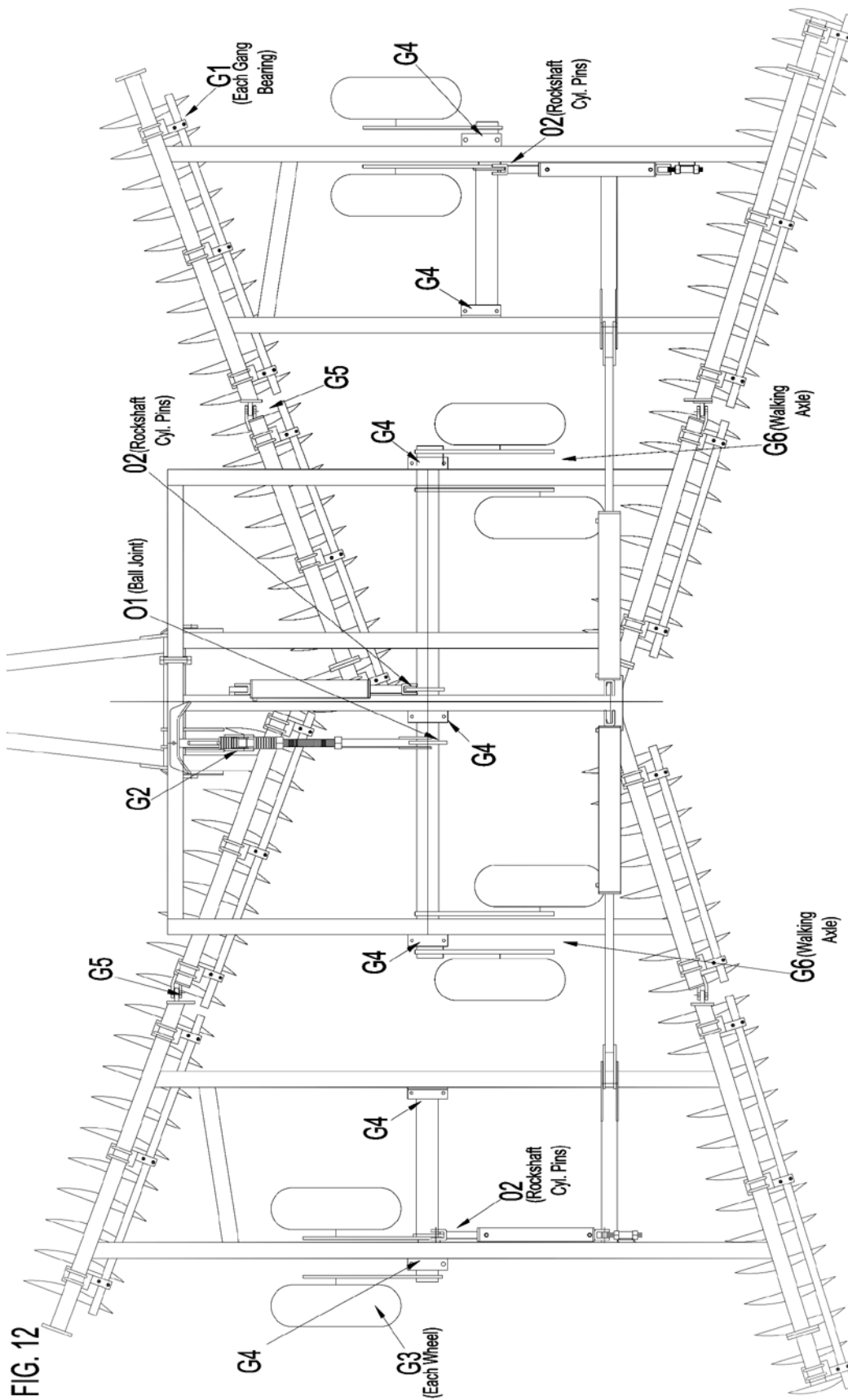

FIG. 12

Maintenance

1. Lubrication - See FIG. 12 - All grease lubricating points on disc are marked with arrow G, use high quality SAE multi-purpose grease. The oil lubrication points are marked with arrow O.

G1 - 410 series gang bearings - lubricate every 20 hours of operation with 6 to 10 strokes of hand grease gun.



CAUTION

For 410 bearings only. If gang bearings are over lubricated, there is a possibility that the seals can be pushed out. This is more likely to happen when bearings are new.

G2 - Lubricate levelling crank every 100 hours of operation.

G3 - Lubricate wheels every 50 hours of operation.

G4 - Lubricate top and bottom half of each rockshaft bearing every 20 hours of operation.

G5 - Lubricate wing hinge points every 100 hours of operation.

G6 - Lubricate walking axles every 50 hours of operation.

NOTE: When you receive your new disc, grease all lubricating points before starting to disc. However, use caution when lubricating 410 series gang bearings. These gang bearings are filled with grease at the factory and seals may be damaged if over lubricated.

01 - Lubricate levelling crank ball joint (with oil) at the end and beginning of each season.

02 - Lubricate rockshaft cylinder pins (with oil) every 50 hours of operation.

2. All bolts and nuts should be checked periodically to make sure they are tight. Special attention should be given to gang bolts, bearing bolts and bearing hanger U-Bolts and wheel bolts.

They should be tightened as follows:

- Gang bolts 1-15/16" (49 mm) diameter - tighten to 3200 ft lbs torque (4339N.m)

See FIG. 13. To tighten gang bolt to 3200 ft lbs (4339N.m) install a 10ft (3.048m) bar in socket wrench and apply 320 lbs (145Kgs) of force to end of bar.

NOTE: After repairing a gang, the gang bolt should be retightened after 2 hours of operation.

FIG. 13

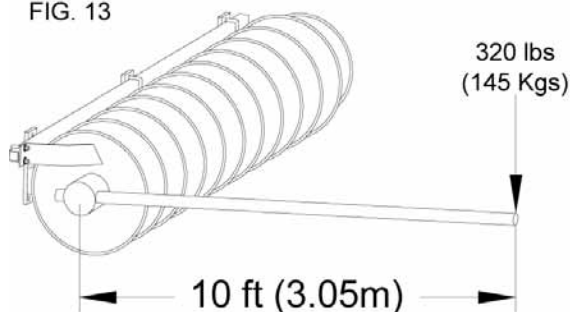



CAUTION

Severe damage will occur if gang bolts are loose.

- Levelling crank bolt 1-1/4" (31.7 m) diameter - 840 ft lbs torque (minimum/maximum) (1139 N.m)
- Wheel bolts 9/16" (14.2 m) diameter - 130 ft lbs torque (176.2 N.m)
- Bearing hanger U-Bolts - 5/8" (15.7mm) diameter - 150 ft lbs torque (20.75m.kgs) - solid hangers
 - 3/4" (19mm) diameter - 260 ft. lbs torque (36m. kgs) - stone flex hangers

3. When storing disc for a long period of time, grease all lubricating points.
4. Keep the pressure equal on all wheels. See specifications for tire pressure. Check the tire tread periodically for nicks, cuts or abrasions.



CAUTION

Do not service disc while it is in motion. You may fall in front of disc and be seriously injured.



CAUTION

Lower the disc to the ground when servicing or making adjustments. If the disc must be serviced or adjusted in raised position, place blocks under frame. Do not rely on hydraulic lock up valve as a safety device. If the hydraulic system failed, the disc could drop.

5. Wing lift cylinder removal - See FIG. 14. If possible lower wings to field position if the wing lift cylinder hydraulic system must be serviced or repaired. If wing lift cylinder hydraulic system must be serviced or repaired with wings in folded position, install a safety chain between each wing frame and main frame to prevent wings from falling down. Always install a chain on both wings even if only one cylinder is being worked on.

FIG. 14

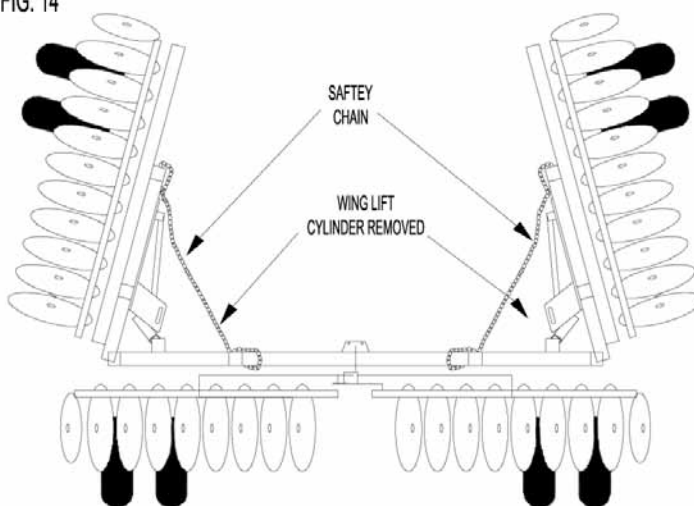

6. Keep all safety decals clean and in good condition to provide a constant reminder of safe operating procedures
7. Replace any destroyed, missing or illegible decals and reflectors.

	<p><u>CAUTION</u> Always relieve the pressure in hydraulic system and close both hydraulic lockup valves when the disc is not being operated.</p>
---	--

8. At the end of each season do following:

A - Relieve pressure in all hydraulic cylinders. Disconnect hydraulic hoses from tractor and cap them.

B - If disc is to be stored outdoors, cover hydraulic cylinders and hoses with weather proof material and coat all exposed cylinder shafts with grease.

C - Set planks under each wheel.

D - Lubricate all grease points.

E - Check disc for worn or damaged parts. Replace damaged parts during the off season.

F - Touch up any scratches with red paint.

NOTE: When storing disc, do not leave cylinders under hydraulic pressure, especially if cylinders are activated during cool temperatures. The thermal expansion of oil which takes place when machine is in a warmer environment may cause serious damage to cylinders or hoses. Always release hydraulic pressure and close lockup valves before unhitching from tractor.

	<p><u>CAUTION</u> Wings may unfold due to thermal expansion of hydraulic oil causing damage to disc, property or severe injury or death to person(s) nearby. Release pressure</p>
---	--

WING LIFT CYLINDER LOCKUP VALVE

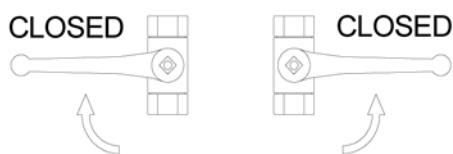

9. Tire maintenance and safety:

- A** - Keep the pressure equal on all wheels. See specifications for correct tire pressure.
- B** - Do not inflate tires above recommended pressure.
- C** - Only experienced personal should attempt to repair a tire or mount a tire on wheel.
- D** - Do not weld or heat tire and wheel assembly when tire is inflated. The heat may cause an increase in tire pressure causing tire to explode.
- E** - Periodically check tires for cuts, bulges and damaged rims.



CAUTION

When inflating tires use a clip on chuck and hose extension which will allow operator to stand clear of tire and wheel assembly. DO not stand in front of or over tire when inflating. Exploding tire and wheel parts can cause serious injury or death.

Troubleshooting

Problem	Possible Cause	Remedy
Outside blades of front gangs are cutting too deep causing disc to ridge at outside.	Wheel raised off ground causing front of disc to drop.	Lower wheels to ground so they gauge discing depth.
	Tire pressure is low on outer wheels causing disc to cut deep at outside.	Inflate tire.
	Disc is lower at front than rear.	Using levelling crank raise front of disc.
	Wing wheel not adjusted for proper cutting depth	Raise outside of wing by adjusting lift cylinder I-Bolt
	Wing rockshaft cylinders are not synchronized with center from rockshaft cylinders	Rephase rockshaft cylinders
Outside blades of front wings are not cutting deep enough	Disc is higher at front than at rear	Using levelling crank raise front of disc
Outside blades on and rear gangs are cutting too deep.	Tire pressure is low for wing wheels causing wings too cut deeper	Check tire inflation for all wheels, see tire pressure
	Outside of wing frame(s) is lower than main frame.	raise outside of wing with wing rockshaft cylinder anchor bolt
	wing rockshaft cylinder(s) is not synchronized with main frame rockshaft cylinder.	Rephrase rockshaft cylinder(s)
Outside blades on front and rear gangs are not cutting deep enough.	Tire pressure is lower on centre section wheels than wing section wheel causing centre section to cut deeper	Check tire inflation for all wheels
	Outside of wing frame is higher than main frame.	Lower outside of wing with wing rockshaft cylinder anchor bolt.
	wing rockshaft cylinder(s) is not synchronized with main frame rockshaft cylinder.	Rephrase rockshaft cylinder(s).
Disc is leaving a ridge at centre of discing.	Rear gangs are cutting deeper than front gangs.	Level disc using levelling crank.
	A high discing speed is causing disc to throw dirt further resulting in a pile at centre.	Reduce discing speed.
	Rear gangs are too close together.	Increase distance between rear gangs.

Problem	Possible Cause	Remedy
rear gangs are not filling furrow left by front gangs at center of disc	Front gangs are cutting deeper than rear gangs.	Level disc using levelling crank.
	A low discing speed is causing disc to not throw dirt far enough to fill furrow left by front centre blades.	Increase discing speed.
	Rear gangs are too far apart.	Decrease distance between rear gangs.
Front gangs are leaving unbroken ground at centre of disc.	Scrapers are too far from blades.	Adjust overlap of front gangs.
Disc gangs are plugging	Piston seals on wing rockshaft cylinder(s) are damaged	Replace piston seals of wing rockshaft cylinder
When raising disc out of ground, outside of wing comes out of ground while main frame lags behind or does not come out of ground.	Piston seals on main frame rockshaft cylinder is damaged	Replace piston seals of main frame rockshaft cylinder.
When raising disc out of ground, main frame rockshaft cylinder is fully extended while wing rockshaft cylinder is not fully extended.	Rockshaft cylinders are not synchronized.	Rephrase rockshaft cylinder.
When raising disc out of ground, wing rockshaft cylinder is fully extended while main frame rockshaft cylinder is not fully extended.	Rockshaft cylinders are not synchronized.	Rephrase rockshaft cylinder.
Outer wing blades will not penetrate soil	Soil condition too hard for your machine	Add weights to outside of wing frame
All section of disc will not penetrate soil	Soil condition too hard for your machine	Contact your dealer

Frame Assembly

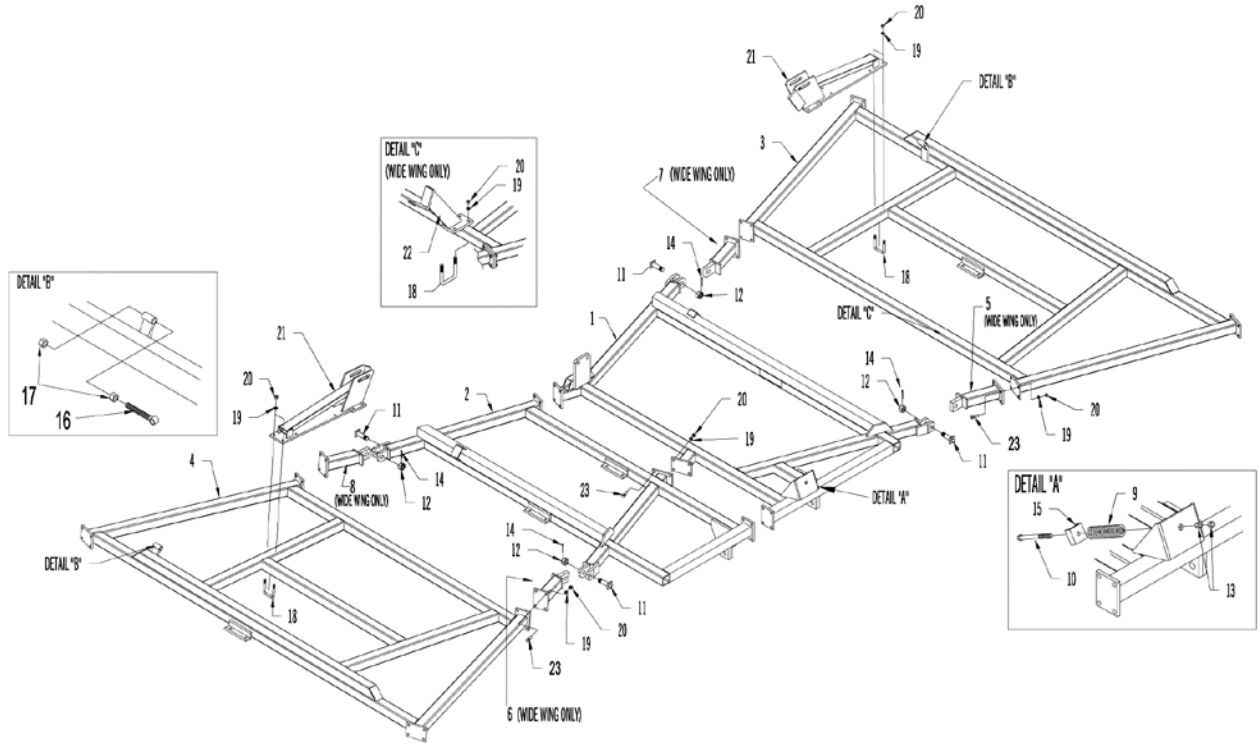

Item	Part #	Description	Qty
1	DF13502	L.H. Main frame half (c/w ref. #'s 6, 7, 8, 9, 10, 11 and 12)	1
2	DF13504	R.H. Main Frame half (c/w ref. #'s 8, 9, and 11)	1
3	DW13506	L.H. Wide Wing Frame - 93" (2362 mm) overall width for 28' (8.53m) models and larger (c/w gang beam shims and 3/4" (19.1 mm) x 2-1/2" (63.5 mm) gang beam bolts, with nuts and lockwashers)	1
	DW13507	L.H. Narrow Wing Frame - 65" (1651 mm) overall width for 27' (8.23m) models and smaller (c/w gang beam shims and 3/4" (19.1 mm) x 2-1/2" (63.5 mm) gang beam bolts, with nuts and lockwashers)	1
4	DW13508	R.H. Wide Wing Frame - 93" (2362 mm) overall width for 28' (8.53m) models and larger (c/w gang beam shims and with 3/4" (19.1 mm) x 2-1/2" (63.5 mm) gang beam bolts, with nuts and lockwashers)	1
	DW13509	R.H. Narrow Wing Frame - 65" (1651 mm) overall width for 27' (8.23m) models and smaller (c/w gang beam shims and 3/4" (19.1 mm) x 2-1/2" (63.5mm) gang beam bolts, with nuts and lockwashers)	1
5	DWA13540	Hinge Arm - Front L.H. - Wide Wing Only	2
6	DWA13541	Hinge Arm - Front R.H. - Wide Wing Only	2
7	DWA13544	Hinge Arm - Rear L.H. - Wide Wing Only	2
8	DWA13545	Hinge Arm - Rear R.H. - Wide Wing Only	2
9	DC9615	10-7/8" (276.2 mm) long compression	1
10	B100140	1" (25.4 mm) x 14" (355.6 mm) N.C. hex bolt - Gr. 5	1
11	DG13009	1-1/2" (38.1mm) x 5" (127mm) Hinge Pin	4
12	DH5165	1-1/2" (38.1 mm) N.C. hex slotted nut	4
13	BN100	1" (25.4 mm) N.C. hex nut	2
14	BP31225	5/16" (7.94mm) x 2-1/4" (57.2mm) Cotter Pin	4
15	DFA10536	Single Spring Cushion Plate	1
16	DFA9564	1-1/4" (31.7mm) N.C. I-Bolt Cylinder Lug	2
17	BN125	1-1/4" (31.7mm) N.C. Hex Nut	4
18	C55203	3/4" (19.1mm) x 4" (101.6mm) x 5-5/16" (134.9mm) U-Bolts	10
19	BW075L	3/4" (19.1mm) Lockwasher	48
20	BN075	3/4" (19/1mm) N.C. Hex Nut	48
21	DF13536	Wing Lift Bracket	2
22	DF13537	Front Wing Support (Wide Wing Only)	2
23	BO75025	3/4" (19.1mm) x 2-1/2" (63.5mm) hex head bolt	6

Gang Beam Assembly

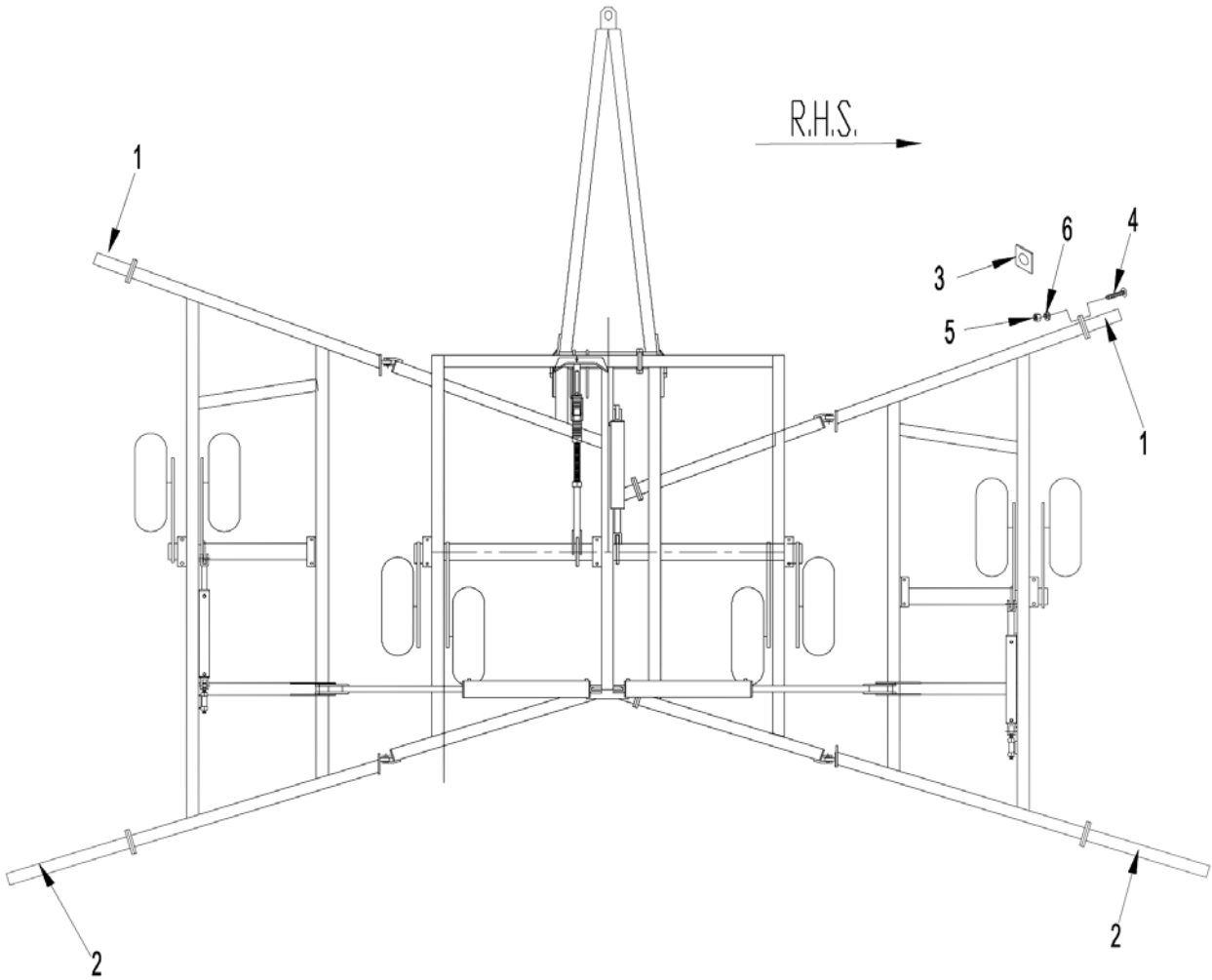

Item	Part #	Description	Qty
1		8" Spacing	
	DG13511	12" (304.8mm) Front Wing Gang Beam - 94 blade	2
	DG13512	18" (457.2mm) Front Wing Gang Beam - 106 blade	2
	DWA10198	36" (914.4mm) Front Wing Gang Beam - 114 blade	2
	DG13513	50" (1270mm) Front Wing Gang Beam - 122 blade	2
	DG13514	60" (1524mm) Front Wing Gang Beam - 126 blade	2
		9" Spacing	
	DWA10192	16" (406.4 mm) Front Wing Gang Beam - 86 & 94 blade	2
	DWA10198	36" (914.4mm) Front Wing Gang Beam - 102 Blade	2
	DWA10202	42" (1066.8 mm) Front Wing Gang Beam - 106 blade	2
	DG13515	60" (1524mm) Front Wing Gang Beam - 114 blade	2
2		8" Spacing	
	DG13516	12" (304.8mm) Rear Wing Gang Beam - 82 blade	2
	DWA10202	42" (1066.8 mm) Rear Wing Gang Beam - 94 & 106 blade	2
	DG13517	60" (1524mm) Rear Wing Gang Beam - 114 blade	2
	DG13518	78" (1981mm) Rear Wing Gang Beam - 122 blade	2
	DG13519	90" (2286mm) Rear Wing Gang Beam - 126 blade	2
		9" Spacing	
	DG13526	16" (406.4mm) Rear Wing Gang Beam - 74 blade	2
	DWA10202	42" (1066.8mm) Rear Wing Gang Beam - 86 & 94 blade	2
	DG13527	60" (1524mm) Rear Wing Gang Beam - 102 Blade	2
	DG13528	72" (1829mm) Rear Wing Gang Beam - 106 blade	2
	DG13529	90" (2286mm) Rear Wing Gang Beam - 114 blade	2
3	DF10046	Gang Beam Shim	*
4	BO75025	3/4" (19.1 mm) x 2-1/2" (63.5 mm) N.C. hex bolt Gr. 5 (plated)	32
5	BN075	3/4" (19.1 mm) N.C. hex nut (plated)	32
6	BW075L	3/4" (19.1 mm) Lockwasher (plated)	32

Decals (Frame and Gang Beam)

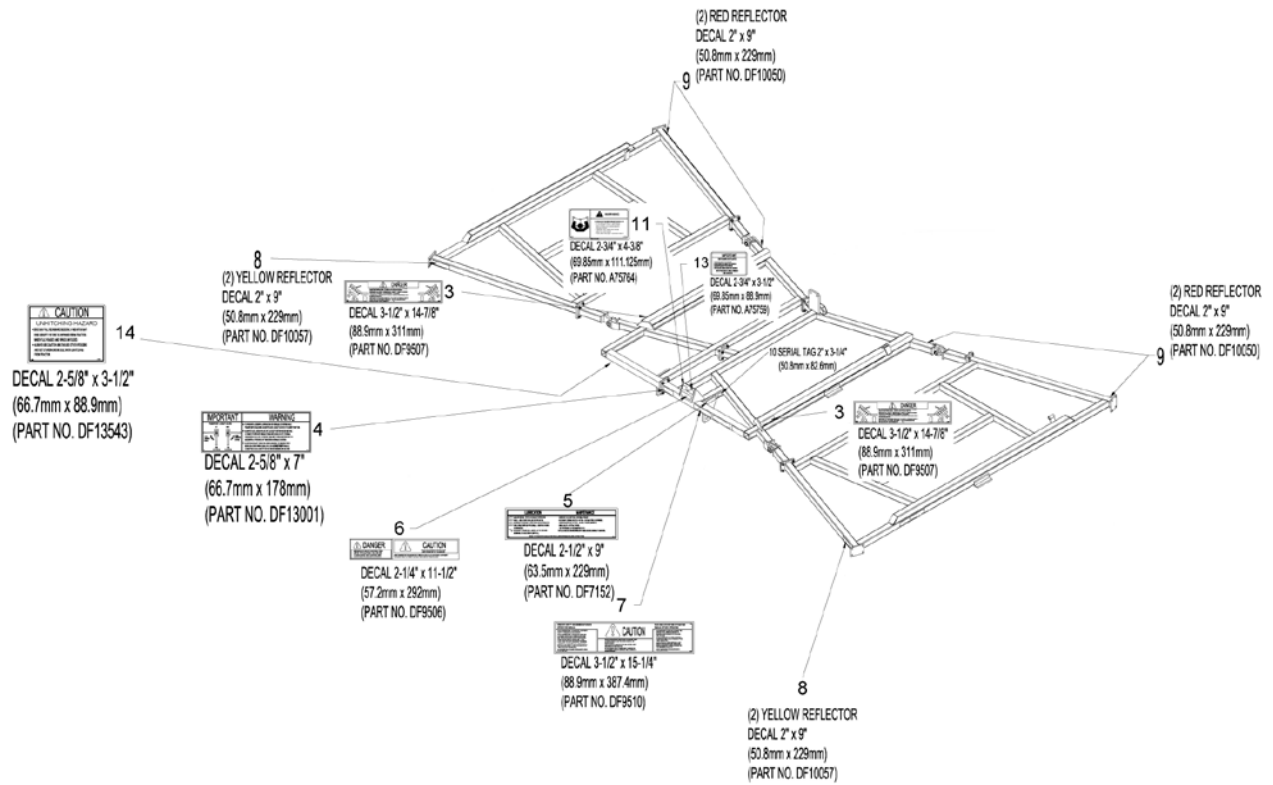

Item	Part #	Description	Qty
3	DF9507	Danger Decal (3-1/2" (88.9mm) x 14-7/8" (311mm))	2
4	DF13001	Hydraulic Lockup Decal (2-5/8" (66.7mm) x 7" (178mm))	1
5	DF7152	Maintenance Decal (2-1/2" (63.5mm) x 9" (229mm))	1
6	DF9506	Danger, Caution Decal (2-1/4" (57.2mm) x 11-1/2" (292mm))	1
7	DF9510	Caution Decal (3-1/2" (88.9mm) x 15-1/4" (387mm))	1
8	DF10057	Yellow Reflector (2" (50.8mm) x 9" (228.6mm))	6
9	DF10050	Red Reflector (2" (50.8mm) x 9" (228.6mm))	6
10	A70023	Serial Tag (2" (50.8mm) x 3-1/4" (82.6mm))	1
11	A75764	Read Manual Decal (2-5/16" (58.6mm) x 4-1/2" (114.3mm))	1
12	DF9510	Safety Recommendation Decal (3-1/2" (88.9mm) x 15-1/4" (387.4mm))	1
13	A75759	Important Decal (2-5/8" (66.7mm) x 4-3/4" (120.7mm))	1
14	DF13543	Caution Decal (2-5/8" (66.7mm) x 3-1/2" (88.9mm))	1
	L010	1 Liter black paint	*
	L016	1/2 pint black paint	*

*as required

Hitch and Leveling Crank Assembly

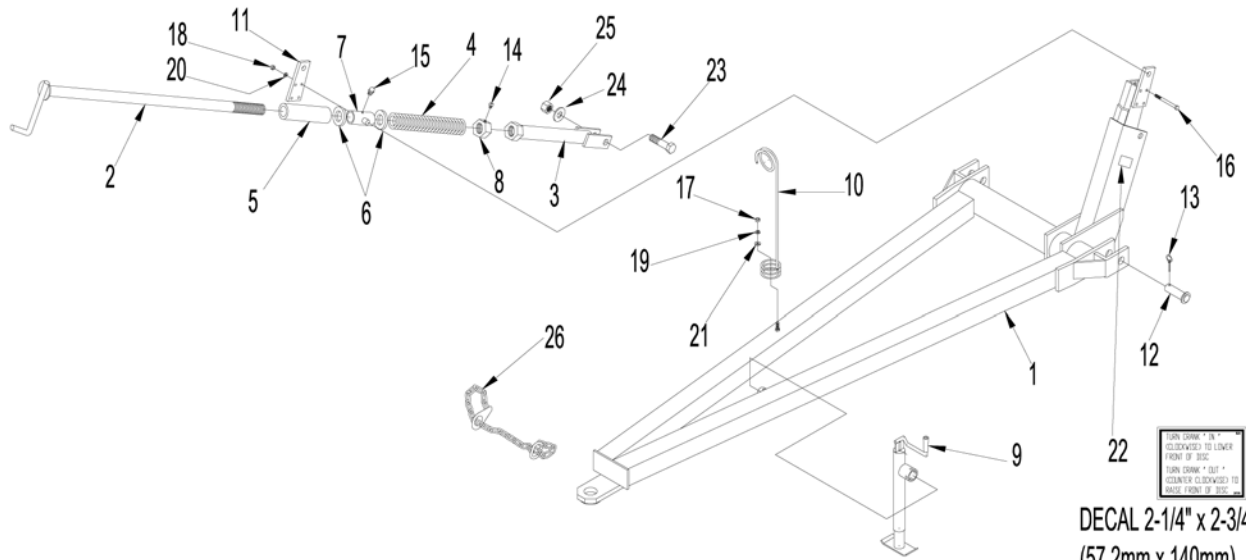

Item	Part #	Description	Qty
1	DHB13097	Hitch c/w items 11, 12, 13 and 18	1
2	DCA9970	Leveling Crank - 50" (1270mm) Long	1
3	DC13530	Leveling Link (11-1/2" (291.2 mm) Pipe Length)	1
4	DC9618	Compression Spring	1
5	DC13098	Spacer Tube (2-3/8" (60.2mm) O.D. x 3/16" (4.76mm) I.D. x 11" (279mm) Long)	1
6	DC15	Thrust Bearing - Timken #T199	2
7	DCA5184	Bearing Tube - leveling crank	1
8	DH5	2" (50.8mm) N.C. Heavy Hex Nut - drilled for set screw	1
9	DHB5170	Hitch Jack	1
10	DH9961	Hose Support - spring coil type	1
11	DH5146	Leveling Arm Lug	1
12	DHA960S	Hitch Pin - 1-1/2" (38.1mm) Dia. x 5" (127mm)	2
13	DH12517	7/16" (10.9mm) x 1-7/16" (36.3mm) Lynch pin	2
14	BO50010S	1/2" (12.7mm) x 1" (25.4mm) N.C. Square Head Set Screw	1
15	10GN1	1/4" (6.35mm) - 28 Straight Grease Fitting	1
16	BO50050	1/2" (12.7mm) x 5" (127mm) N.C. Hex Bolt	4
17	BN062	5/8" (15.7mm) N.C. Hex Nut	1
18	BN050	1/2" (12.7mm) N.C. Hex Nut	4
19	BW062L	5/8" (15.7mm) Lockwasher	1
20	BW050L	1/2" (12.7mm) Lockwasher	4
21		11/16" (17.2mm) I.D. x 1-3/4" (44.4mm) O.D. Flatwasher	1
22	DH7148	Crank Decal (2-1/4" (57.2mm) x 2-3/4" (140mm))	1
23	DR5215	1-1/4" (31.7mm) x 4-3/4" (120.6mm) N.C. Hex Bolt w/ special thread length	1
24	BW125L	1-1/4" (31.7mm) Lockwasher	1
25	BN125	1-1/4" (31.7mm) N.C. Hex Nut	1
26	D13090	Safety Chain - 20200 lbs	1

Rockshaft and Wheel Assembly

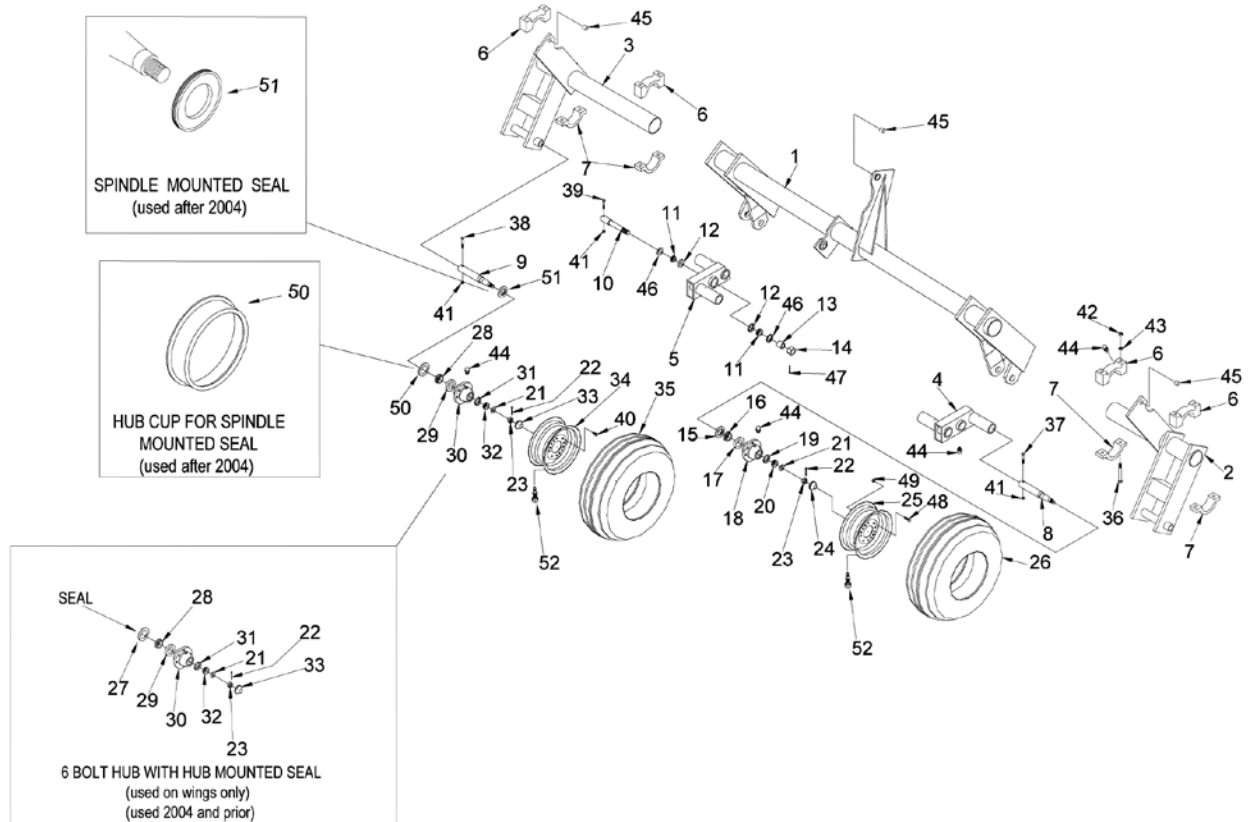

Item	Part #	Description	Qty
1	DRA13531	Main Frame Rockshaft	1
2	DRA13532	L.H. Wing Rockshaft Assembly - 50"	1
3	DRA13533	R.H. Wing Rockshaft Assembly - 50"	1
4	DRA13131	L.H. Walking Beam Main Frame	1
5	DRA13130	R.H. Walking Beam Main Frame	1
6	DR8601T	Rockshaft Bearing - Top Half	4
7	DR8601B	Rockshaft Bearing - Bottom half	4
8	DR13004	812 Spindle - 13-3/4" (348mm)	4
9	DR7156	618 Spindle - 14-1/2" (368mm)	4
10	DR13007	Pivot Bolt - Main Frame Walking Beam	2
11	DR13124	Cone Bearing # 25877	4
12	DR13125	Bearing Cup #25821	4
13	DR13008	Sleeve-Pivot Pin	2
14	DR13126	1-1/4" (31.7mm) N.F. Slotted Hex Nut	2
15	DR9680	Grease Seal #SE-17	4
16	DR9684	Inner Cone Bearing #3780	4
17	DR9682	Inner Cup #3720	4
18	DRA9679	Hub c/w Cups - 8 Bolt	4
19	DR9683	Outer Cup #2720	4
20	DR9685	Outer Cone Bearing #2790	4
21	BW20010612F	2" (50.8mm) O.D. x 1-1/16" (25.5mm) I.D. x 1/8" (3.18mm) Flatwasher	4
22	BP18125	3/16" (4.76mm) x 1-1/4" (31.7mm) Cotter Pin	4
23	DR110	1" (25.4mm) N.F. Hex Slotted Nut	4
24	DR9681	Hub Cap	4
25	S81509	15" (381mm) x 10" (254mm) x 8 Bolt Rim	4
26	--	11L x 15 F FITire	4
27	DR122	Grease Seal - (used 2004 and prior)	4
28	DR120	Cone Bearing - #LM25580	4
29	DR118	Cup - #LM25520	4
30	DRA9	618 Hub c/w Cups	4
31	DR92	Cup - #LM48510	4
32	DR91	Cone Bearing - #LM48548	4
33	DR123	Hub Cap	4
34	DR5261	15" (381mm) x 8" (203mm) - 6 Bolt Rim - (requires metal valve stem)	4
35	--	11L x 15 D F1Tire	4
36	BO75065	3/4" (19mm) x 6-1/2" (165mm) N.C. Hex Bolt Gr.5 (plated)	4
37	BO50045	1/2" (12.7mm) x 4-1/2" (114.3mm) N.C. Hex Bolt (plated)	4
38	BO50035	1/2" (12.7mm) x 3-1/2" (88.9mm) N.C. Hex Bolt (plated)	4
39	BO50030	1/2" (12.7mm) x 3" (76.2mm) N.C. Hex Bolt (plated)	4

Item	Part #	Description	Qty
40	DR125	9/16" (14.2mm) N.F. x 1-1/8" (28.5mm) Wheel Bolt	56
41	BN050L	1/2" (12.7mm) N.C. Nylon Locknut (plated)	10
42	BN075	3/4" (19mm) N.C. Hex Nut (plated)	8
43	BW075L	3/4" (19mm) Lockwasher (plated)	8
44	10GN1	1/4" (6.35mm) - 28 Straight Grease Fitting	18
45	10GN3	Grease Fitting - Press in Type	8
46	DR13120	1-1/4" (31.8mm) I.D. x 1-1/4" (31.8mm) Long Steel Insert	3
47	DR13121	Seal - P/N 18823	1
48	BP31200	5/16" (7.8mm) x 2" (50.8mm) Cotter Pin	1
49	DR9671	9/16" N.F. x 1-11/16" Wheel Bolt	32
50	DR9672	9/16" N.F. Hex Nut	32
51	DR13191	Seal Cup - Spindle Mount Type Seal - (used after 2004)	4
52	DR13190	Seal - Spindle Mount Type - (used after 2004)	4
	C60154	Valve Stem - Metal	8

*as required

Hydraulic Assembly - Wide and Narrow Wing

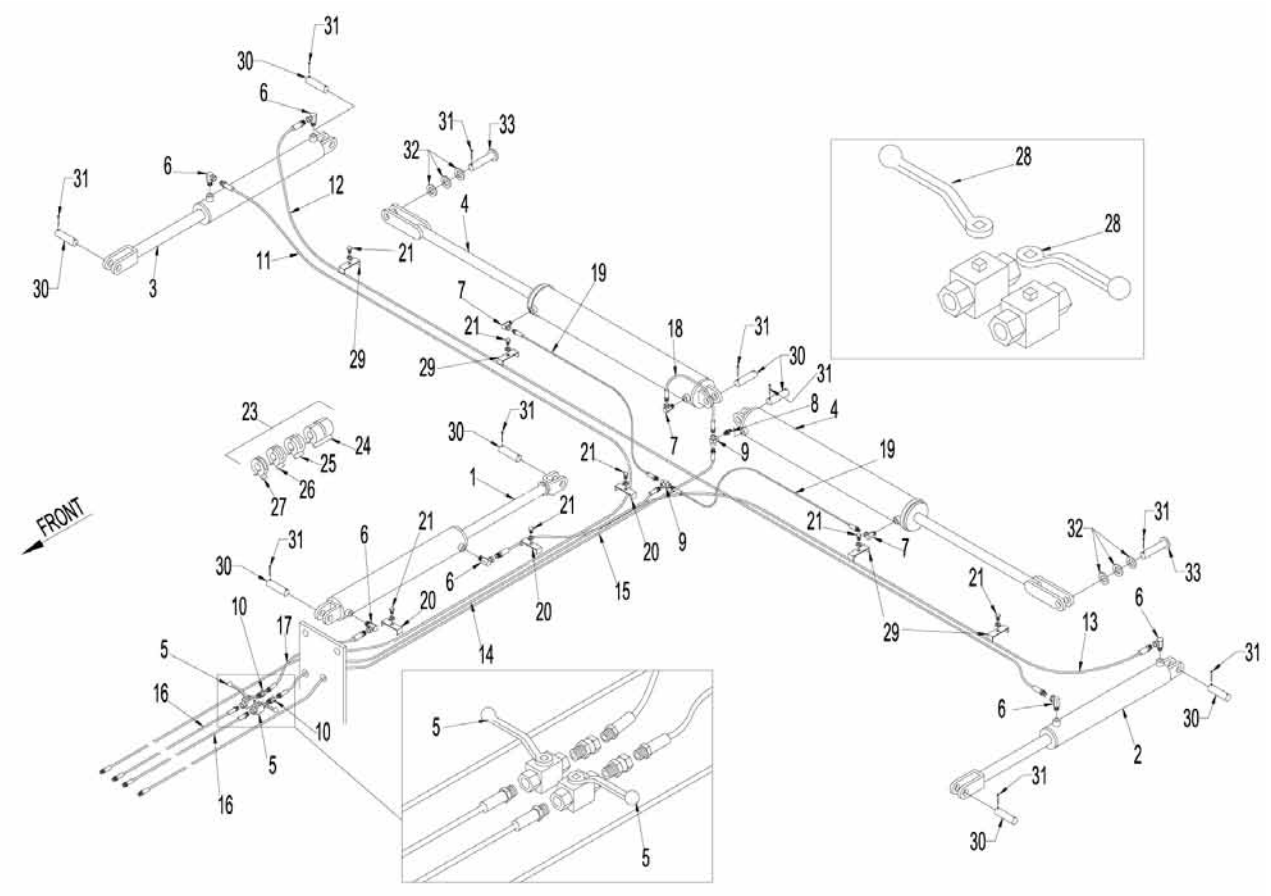

Item	Part #	Description	Qty
1	306	4" (101.6mm) x 24" (610mm) Hydraulic Cylinder	1
2	305	3-1/2" (88.9mm) x 24" (610mm) Hydraulic Cylinder	1
3	304	3" (76.2mm) x 24" (610mm) Hydraulic Cylinder	1
4	242	5" (127mm) x 36" (914mm) Wing Lift Cylinder	2
5	DL13099	Hydraulic Lockout Valve	2
6	DL9775	1/2" (12.7mm) x 90 Degree Swivel Street Elbow	6
7	DL9769	3/8" (9.39mm) x 90 Degree Swivel Street Elbow	3
8	S82371	3/8" (9.39mm) Male-Male Union	1
9	DL9767	3/8" (9.39mm) x 3/8" (9.39mm) x 3/8" (9.39mm) Swivel Tee	2
10	L1619	3/8" (9.39mm) Male-Female Swivel	2
11	D4375	3/8" (9.39mm) x 426" (10820mm) Hydraulic Hose c/w 1/2" (12.7mm) Ends (Narrow Wing)	1
	D4376	3/8" (9.39mm) x 462" (11735mm) Hydraulic Hose c/w 1/2" (12.7mm) Ends (Wide Wing)	1
12	D4377	3/8" (9.39mm) x 312" (7925mm) Hydraulic Hose c/w 1/2" (12.7mm) Ends (Narrow Wing)	1
	D4378	3/8" (9.39mm) x 384" (9754mm) Hydraulic Hose c/w 1/2" (12.7mm) Ends (Wide Wing)	1
13	P4332	3/8" (9.39mm) x 208" (5283mm) Hydraulic Hose c/w 1/2" (12.7mm) Ends (Narrow Wing)	1
	D4379	3/8" (9.39mm) x 244" (6198mm) Hydraulic Hose c/w 1/2" (12.7mm) Ends (Wide Wing)	1
14	D4380	3/8" (9.39mm) x 102" (2591mm) Hydraulic Hose c/w 3/8" (9.39mm) Ends	1
15	D4381	3/8" (9.39mm) x 294" (7468mm) Hydraulic Hose c/w 3/8" (9.39mm) Ends	1
16	D4382	3/8" (9.39mm) x 179" (4547mm) Hydraulic Hose c/w 3/8" (9.39mm) Ends	2
17	P4336	3/8" (9.39mm) x 20" (508mm) Hydraulic Hose c/w 3/8" (9.39mm) End & 1/2" (12.7mm) End	1
18	L2939	3/8" (9.39mm) x 24" (610mm) Hydraulic Hose c/w 3/8" (9.39mm) Ends	1
19	P3027	1/4" (6.35mm) x 54" (1372mm) Hydraulic Hose c/w 3/8" (9.39mm) Ends	2
20	DL13186	4 Line Hose Clamp	3
21	BO50075	1/2" (12.7mm) x 3/4" (19mm) N.C. Hex Bolt (Plated)	8
23	DR13127	Wadler Universal Stroke Control Segments (8-3/4" (222mm) package)	2
24	C50717	4-1/4" (108mm) Depth Stop	2
25	C50714	2" (50.8mm) Depth Stop	2

Item	Part #	Description	Qty
26	C50712	1-1/2" (38.1mm) Depth Stop	2
27	C50711	1" (25.4mm) Depth Stop	2
28	DL13122	Hyd. Valve Lockout Valve Handle Only - HBVH040608	2
29	DL9766	2 Line Hose Clamp- 1/2" Hose	5
30	DR5262	1-1/4 (31.75mm) x 4-3/4" (120.65mm) Pin	8
31	BP31175	5/16" (8mm) x 1- 3/4" (44mm) Cotter Pin	12
32	--	2" (50.8mm) O.D. x 1-3/4 (31.75mm) I.D. x 1/4" (6.35mm) Flat Washer	6
33	C50727	1-1/4" (31.75mm) x 6-1/4" (158.75mm) Pin	2

Scraper Assembly

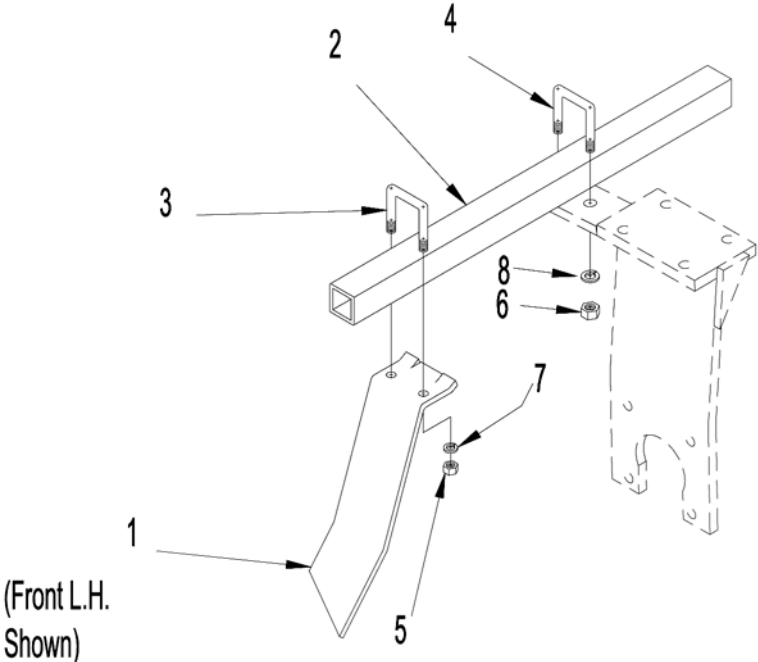

Item	Part #	Description	Qty
1	DG6083	Front R.H., Rear L.H. Scraper	*
	DG6084	Front L.H., Rear R.H. Scraper	*

2		Scraper Bar - 8" (203.2 mm) Spacing	
	DS49	6 Blade Scraper Bar - 49" (1245 mm)	*
	DS65	8 Blade Scraper Bar - 65-1/2" (1664 mm)	*
	DS73	9 Blade Scraper Bar - 73-1/2" (1867 mm)	*
	DS82	10 Blade Scraper Bar - 82" (2083 mm)	*
	DS90	11 Blade Scraper Bar - 90" (2286 mm)	*
	DS99	12 Blade Scraper Bar - 99" (2515 mm)	*
	DS107	13 Blade Scraper Bar - 107" (2718 mm)	*
	DS115	14 Blade Scraper Bar - 115-1/2" (2934 mm)	*
	DS123	15 Blade Scraper Bar - 123-1/2" (3137 mm)	*

		Scraper Bar - 9" (228.6 mm) Spacing	
	DS64	7 Blade Scraper Bar - 64" (1626 mm)	*
	DS73	8 Blade Scraper Bar - 73-1/2" (1867 mm)	*
	DS82	9 Blade Scraper Bar - 82" (2083 mm)	*
	DS92	10 Blade Scraper Bar - 92" (2337 mm)	*
	DS101	11 Blade Scraper Bar - 101-1/2" (2578 mm)	*
	DS110	12 Blade Scraper Bar - 110" (2794 mm)	*
	DS120	13 Blade Scraper Bar - 120" (3048 mm)	*
	DS129	14 Blade Scraper Bar - 129-1/2" (3289 mm)	*
	DS139	15 Blade Scraper Bar - 139" (3531mm)	*

3	DG5308	1/2" (12.7 mm) x 2" (50.8 mm) U-Bolt - Plated	*
4	DG5309	5/8" (15.9 mm) x 2" (50.8 mm) U-Bolt - Plated	*
5	BN050	1/2" (12.7 mm) N.C. Hex Nut - Plated	*
6	BN062	5/8" (15.9 mm) N.C. Hex Nut - Plated	*
7	BW050L	1/2" (12.7 mm) Lockwasher - Plated	*
8	BW062L	5/8" (15.9 mm) Lockwasher - Plated	*

* as required

Disc Gang Assembly

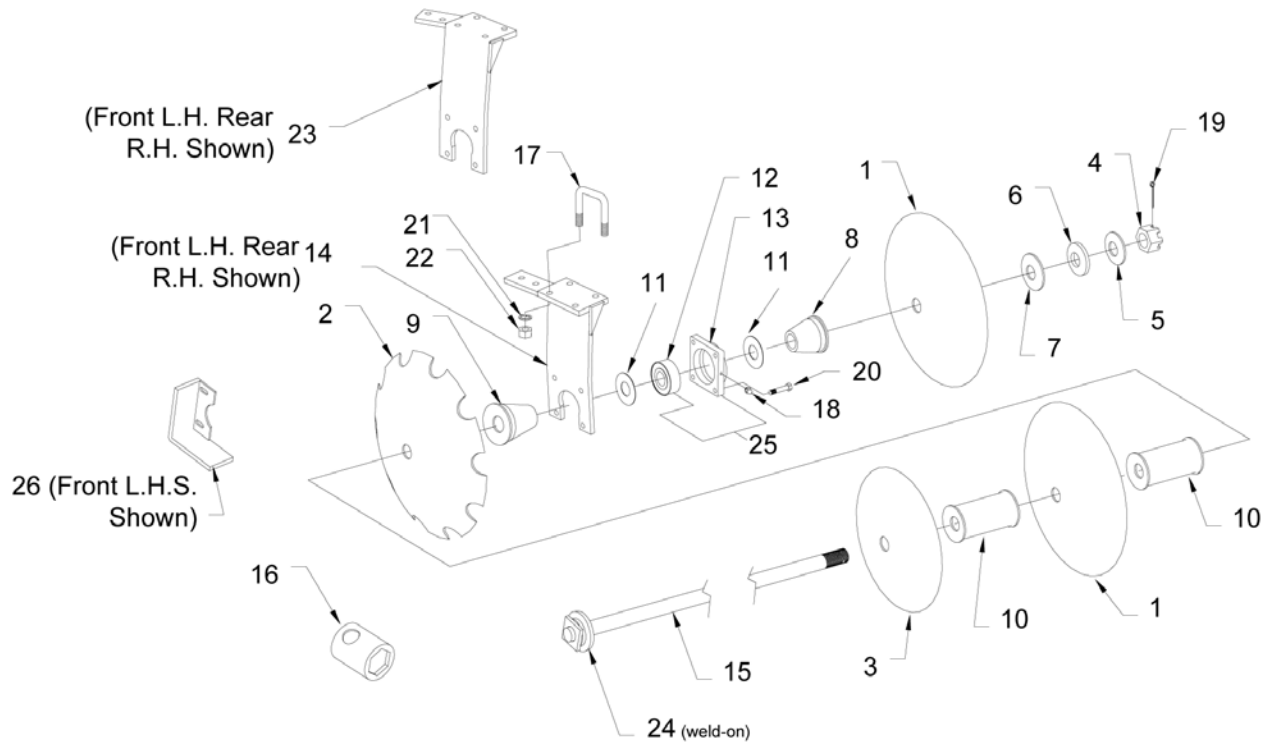

Item	Part #	Description	Qty
1	DG60	22" (558.8 mm) x 7mm (.275) Plain Blade	*
	DG76	24" (609.6 mm) x 7mm (.275) Plain Blade	*
	DG137	24" (609.6 mm) x 8mm (5/16) Plain Blade	*
	DG74	26" (660.4mm) x 8mm (5/16") Plain Blade (Australia Only)	*
2	DG61	22" (558.8 mm) x 7mm (.275) Notched Blade	*
	DG138	24" (609.6 mm) x 8mm (5/16) Notched Blade	*
	DG75	26" (660.4mm) x 8mm (5/16") Notched Blade (Australia Only)	*
3	DG84	16" (406.4 mm) x 4mm (.157) Plain Outrigger Blade	*
	DG133	18" (457.2 mm) x 5mm (.197) Plain Outrigger Blade	*
	DG149	20" (508 mm) x 6mm (.236) Plain Outrigger Blade	*
4	DG82	2" (50.8 mm) Heavy Hex Slotted Nut	*
5	DG89	1/4" (6.35 mm) Shim Washer	*
6	DG88	1/2" (12.7 mm) Shim Washer	*
7	DG78	5" (127mm) O.D. x 2" (50.8mm) I.D. x 5/8" (15.9mm) Head Washer – (used prior to 2003)	*
	DG13184	5-1/2" O.D. x 2" I.D. x 3/4" (139.7mm x 50.8mm x 19.0mm) Head Washer (used with 22" and 24" blades) - used 2003 and later	*
	DG13185	6" O.D. x 2" I.D. x 1" (152.4mm x 50.8mm x 25.4mm) Head Washer (used with 26" blades) - used 2003 and later	*
8	DGA108	8" (203.2mm) Spacing Short Half Spool - 2-3/8" (69.9mm) Long	*
	DGA97	9" (228.6mm) Spacing Short Half Spool - 3-1/4" Long w/ 5" (127mm) Washer	*
9	DGA103	8" or 9" (228.6mm) Spacing Long Half Spool - 4-3/16" (106.3mm) Long for EZ410N Brg	*
	DGA136	8" or 9" (228.6mm) Spacing Long Half Spool - 3-11/16" (93.5mm) for 410WSS Brg	*
10	DGA113	8" (203.2mm) Spacing Full Spool - 8" (203.2mm) Long	*
	DGA98	9" (228.6mm) Spacing Full Spool - 9"(228.6mm) Long w/ 5" (127mm) Washer	*
11	DG236	3-1/2" (88.9 mm) O.D. x 2" (50.8 mm) I.D. x 1/16" (1.59 mm) Bearing Shield - EZ410N Only	*
12	DG5364	EZ410N Series Greaseable Bearing (1-9/16" (39.6mm) wide) – used in USA and Australia prior to June 2005 and used in Canada prior to August 2006.	*
	DG108	410WSS Series Greaseable Bearing (2-1/16" (52.9mm) wide) – used in USA and Australia after June 2005 and used in Canada after August 2006.	*
13	DG96	EZ410N and 410WSS Bearing Housing Only	*
14	DGA10280	Front L.H., Rear R.H. Straight Bearing Hanger - EZ410N & 410WSS Bearing	*
	DGA10281	Front R.H., Rear L.H. Straight Bearing Hanger - EZ410N & 410WSS Bearing	*

Item	Part #	Description	Qty
	DGA13560	Front L.H., Rear R.H. Straight Bearing Hanger - EZ410N & 410WSS Bearing (For 26" (660.4mm) - April 2001 and later Australia only)	*
	DGA13561	Front R.H., Rear L.H. Straight Bearing Hanger - EZ410N & 410WSS Bearing (For 26" (660.4mm) - April 2001 and later Australia only)	*

15		Gang Bolts - 8" (203.2 mm) Spacing	
	DGA86	6 Blade Gang Bolt - 47" (1194mm) Long	*
	DGA88	8 Blade Gang Bolt - 64" (1626mm) Long	*
	DGA89	9 Blade Gang Bolt - 72-1/4" (1835mm) Long	*
	DGA90	10 Blade Gang Bolt - 80-3/4" (2051mm) Long	*
	DGA91	11 Blade Gang Bolt - 89-1/2" (2273mm) Long	*
	DGA92	12 Blade Gang Bolt - 97-1/4" (2470mm) Long	*
	DGA93	13 Blade Gang Bolt - 105-1/2" (2678mm) Long	*
	DGA94	14 Blade Gang Bolt - 113-3/4" (2889mm) Long	*

		Gang Bolts - 9" (228.6 mm) Spacing	
	DGA67	7 Blade Gang Bolt - 61-3/4" (1569mm) Long	*
	DGA68	8 Blade Gang Bolt - 71" (1803mm) Long	*
	DGA69	9 Blade Gang Bolt - 80" (2032mm) Long	*
	DGA70	10 Blade Gang Bolt - 89-1/2" (2273mm) Long	*
	DGA71	11 Blade Gang Bolt - 98-3/4" (2508mm) Long	*
	DGA72	12 Blade Gang Bolt - 108" (2743mm) Long	*
	DGA73	13 Blade Gang Bolt - 117-1/2" (2985mm) Long	*
	DGA74	14 Blade Gang Bolt - 127-1/2" (3239mm) Long	*
	DGA129	15 Blade Gang Bolt - 135-1/4" (3435mm) Long	*

16	DGA35	Socket Wrench	1
17	DG6080	5/8" (15.9mm) x 4" (101.6mm) x 4-7/16" (112.7mm) Long U-Bolt	*
18	10GN1	1/4" (6.35mm) x 28 Grease Fitting	*
19	DG10310	7/16" (11.1mm) x 3" (76.2mm) Lock Pin	*
20	BO50022	1/2" (12.7mm) x 2-1/4" (57.2mm) N.C. Hex Bolt - 211 Bearing - Plated	*
	BO62022	5/8" (15.9mm) x 2-1/4" (57.2mm) N.C. Hex Bolt - 410 Bearing - Plated	*
21	BW050L	1/2" (12.7mm) Lockwasher - 211 Bearing	*
	BW062L	5/8" (15.9mm) Lockwasher - 410 Bearing	*

Item	Part #	Description	Qty
22	BN050	1/2" (12.7mm) Hex Nut - 211 Bearing	*
	BN062	5/8" (15.9mm) Hex Nut - 410 Bearing	*
23	DGA10282	Front R.H., Rear L.H. 2" (50.8mm) Offset Hanger - EZ410N & 410WSS Series	*
	DGA10283	Front L.H., Rear R.H. 2" (50.8mm) Offset Hanger - EZ410N & 410WSS Series	*
	DGA13562	410WSS Series Front L.H., Rear R.H. 2" (50.8mm) Offset Hanger - EZ410N & 410WSS Bearing (For 26" (660.4mm) - April 2001 and later Australia only)	*
	DGA13563	Front R.H., Rear L.H. 2" (50.8mm) Offset Hanger - EZ410N & 410WSS Bearing (For 26" (660.4mm) - April 2001 and later Australia only)	*
24	DGA5370	5-1/2" (139.7 mm) Gang Washer - Weld-on	*
25	DGB5363	EZ410N Housing c/w Bearing and Grease Fitting - used in USA and Australia prior to June 2005 and used in Canada prior to August 2006.	*
	DGB109	410WSS Housing c/w Bearing and Grease Fitting - used in USA	*
26	DGA40	and Australia after June 2005 and used in Canada after August 2006.	*
		Bearing Guard EZ410N & 410WSS Bearing - Front L.H. & Rear R.H.	*
		Bearing Guard EZ410N & 410WSS Bearing - Front R.H. & Rear L.H.	*

* as required

Stone Flex Hanger Assembly

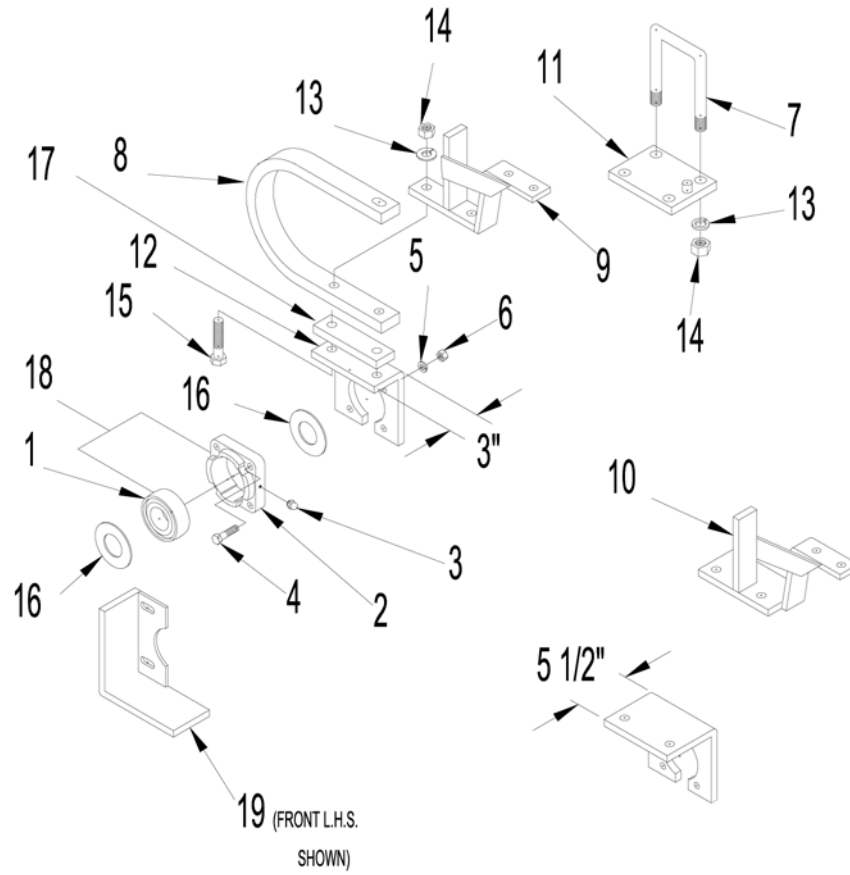

Item	Part #	Description	Qty
1	DG5364	EZ410N series greaseable bearing - 1-9/16" (39.6mm) wide - used in USA and Australia prior to June 20085 and used in Canada prior to August 2006	*
	DG108	410WSS series greaseable bearing - 2-1/16" (52.9mm) wide - used in USA and Australia after June 2005 and used in Canada after August 2006.	*
2	DG96	EZ410N and 410WSS Bearing Housing Only	*
3	10GN1	1/4" (6.35mm) x 23 grease fitting	*
4	BO62022	5/8" (15.9mm) x 2-1/4" (57.2mm) N.C. Hex Bolt - Plated	*
5	BW062L	5/8" (15.9mm) Lockwasher - Plated	*
6	BN062	5/8" (15.9mm) Hex Nut - Plated	*
7	DG10290	3/4" (19.1mm) x 4" (101.6mm) x 7" (177.8mm) Long U-Bolt	*
8	DG8150	1-1/4" (31.2mm) x 2" (50.8mm) Spring Shank	*
9	DGA8612	Scraper Bar Support Bracket - STD Stone Flex Hanger - Front L.H. & Rear R.H.	*
	DGA8611	Scraper Bar Support Bracket - STD Stone Flex Hanger - Front L.H. & Rear R.H.	*
10	DGA8623	Scraper Bar Support Bracket - Offset Stone Flex Hanger - Front L.H. or Rear R.H.	*
	DGA8624	Scraper Bar Support Bracket - Offset Stone Flex Hanger - Front R.H. or Rear L.H.	*
11	DGA10295	Backing Plate - Stone Flex Hanger - 3/4" (19.1mm) U-Bolt	*
12	DGA5324	Mounting Bracket - EZ410N & 410WSS Series - STD Stone Flex Hanger	*
13	BW075L	3/4" (19.1mm) Lockwasher - Plated	*
14	BN075	3/4" (19.1mm) N.C. Hex Nut - Plated	*
15	BO75035	3/4" (19.1mm) x 3-1/2" (88.9mm) N.C. Hex Bolt - Plated (Used when spacer, item 17, is not used)	*
	BO75045	3/4" (19.1mm) x 4-1/2" (114.3mm) N.C. Hex Bolt (Used when spacer, item 17, is used)	*
16	DG236	3-1/2" (88.9mm) O.D. x 2" (50.8mm) I.D. x 1/16" (1.59mm) Bearing Shield - EZ410N Only	*
17	DG5332	Spacer Plate - 3/4" x 2" x 7" (19.1mm x 50.8mm x 177.8mm) - used with 26"	*
18	DGB5363	(660.4mm) Blades on 9" (228.6mm) Spacing (Australia Only)	*
	DGB109	EZ410N Housing c/w Bearing and Grease Fitting - used in USA and Australia prior to June 2005 and used in Canada prior to August 2006.	*
19	DGA40	410WSS Housing c/w bearing and grease fitting - used in USA and Australia after June 2005 and used in Canada after August 2006.	*
	DGA39	Bearing Guard- EZ410N & 410WSS Bearing - Front L.H. & Rear R.H.	*
20	DGA5341	Bearing Guard - EZ410N & 410WSS Bearing - Front R.H. & Rear L.H	*
		Mounting Bracket - 2" (50.8mm) Offset Stone Flex Hanger	*

* as required

Warning Light Kit (Optional)

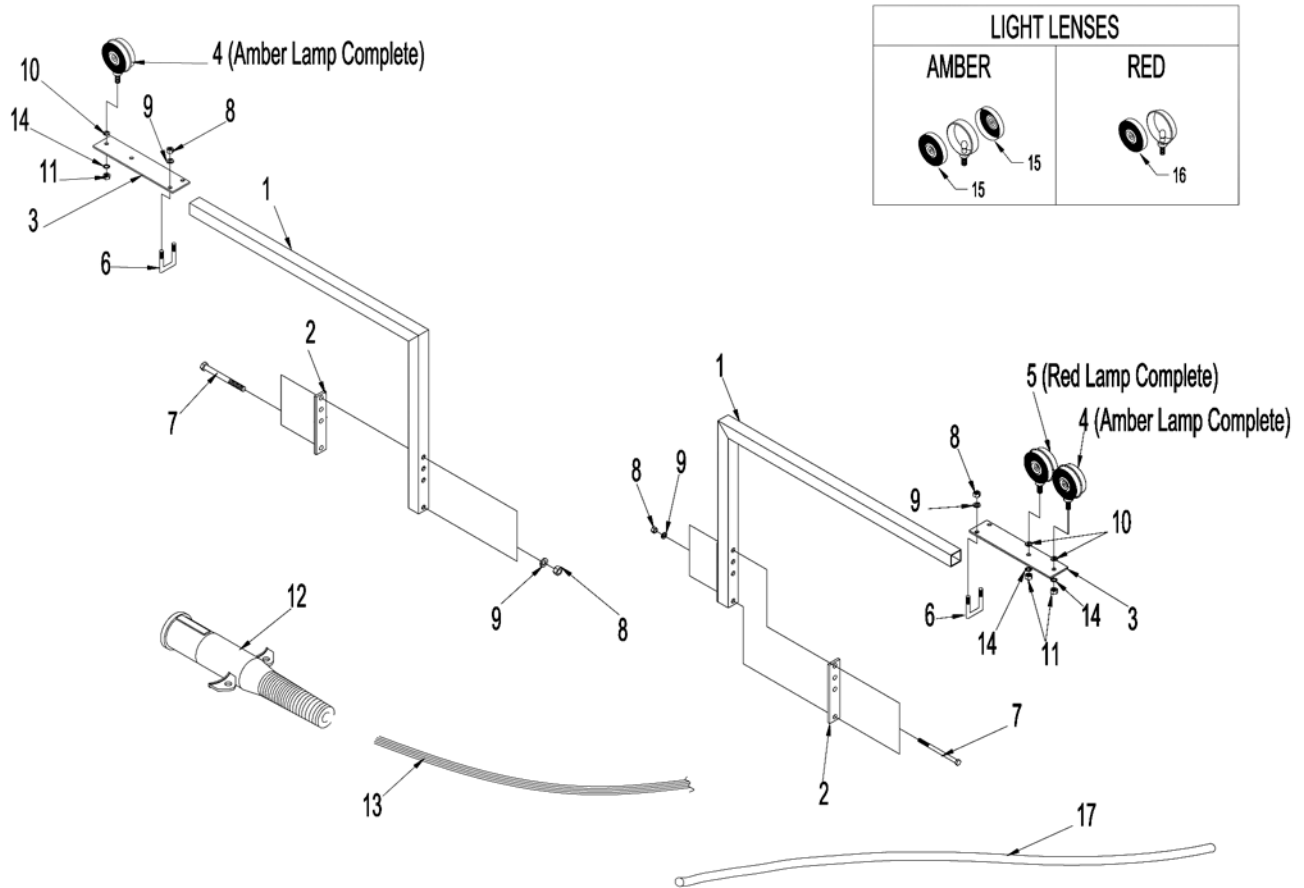

Item	Part #	Description	Qty
1	D13101	Light bracket	2
2	D13102	Backing Plate	2
3	LK6422	Light Mount Plate	2
4	LK6401	Amber Lamp c/w Washers and Nut	2
5	LK6400	Red Lamp c/w Washers and Nuts	1
6	DG5308	1/2" (12.7mm) x 2" (50.8mm) x 3" (76.2mm) U Bolt	2
7	BO50075	1/2" (12.7mm) x 7-1/2" (191mm) N.C. Hex Bolts - Plated	4
8	BN050	1/2" (12.7mm) N.C. Hex Nut - Plated	8
9	BW050L	1/2" (12.7mm) Lockwasher - Plated	8
10	LK6406	1-1/8" (28.6mm) x 1/2" (12.7mm) Rubber Washer	3
11	LK6407	1/2" (12.7mm) Hex Nut - N.F. Fine Thread	3
12	LK6423	Male Plug Complete	1
13	LK6408	55 ft Electrical Wire (White/Yellow/Brown/Green) - Supplied in Bulk - Stripping & Cutting Required	1
14	--	1/2" (12.7mm) Starwasher	3
15	LK6409	Amber Lens - For Red Lamps	4
16	LK6410	Red Lens - For Red Lamps	1
17	D13117	Plastic Loom - 25' (7.6m) - 1/2" (12.7mm) Loom	1
		Plastic Loom - 12' (3.7m) - 3/8" (9.4mm) Loom	1

Stabilizer Beam Assembly

- Used on 40' and 40-1/2' (12.9 m & 12.34m) Sizes Only

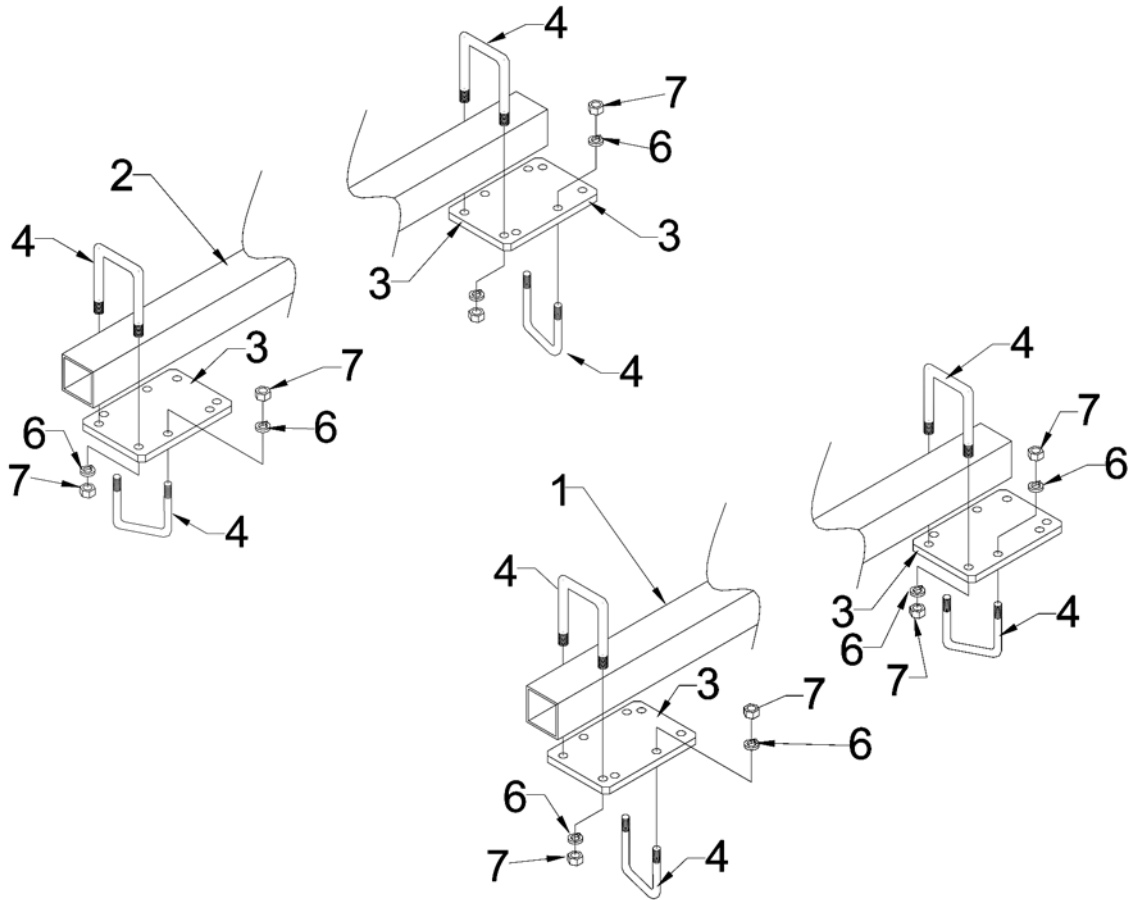

Item	Part #	Description	Qty
1	DG13538	Stabilizer beam 242" - R.H.	1
2	DG13539	Stabilizer beam 220" - L.H.	1
3	DG13542	Mount plate	4
4	C55203	3/4" (19.1mm) x 4" (101.6mm) x 5-5/8" (142.8mm) U-Bolt	16
5	BN075	3/4" (19.1mm) N.C. Hex Nut	32
6	BW075L	3/4" (19.1mm) Lockwasher	32

* as required

Rockshaft Cylinder

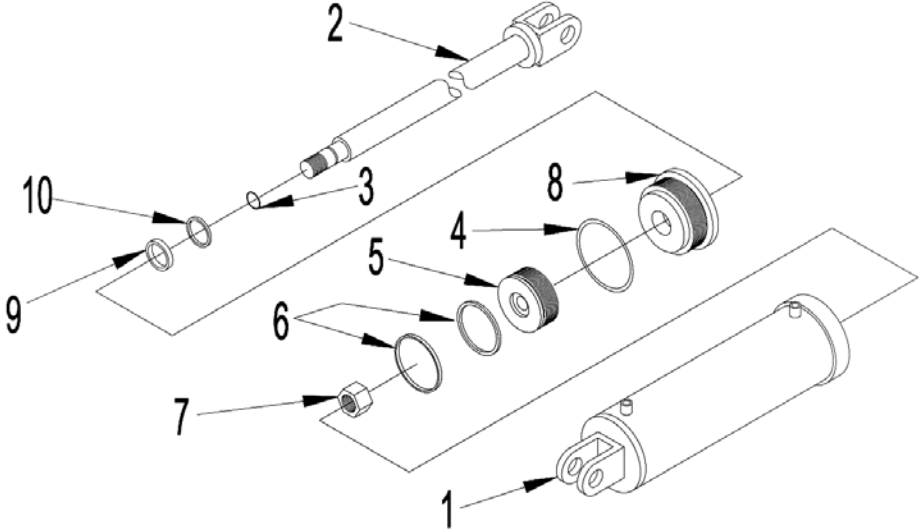

Item	Part #	Description	Qty
------	--------	-------------	-----

R.H. Main Rockshaft Cylinder - 4" (101.6 mm) x 24" (610 mm) Rephasing Cylinder #306			
1	40TU10	Tube Assembly - 4" (101.6mm) x 24" (610mm)	1
2	10SH60	Shaft - 2" (50.8mm) x 24" (610mm)	1
3	10OR18	1" (25.4mm) O.D. x 7/8" (22.2mm) I.D. O-Ring	1
4	10OR17	4" (101.6mm) O.D. x 3/16" (4.76mm) O-Ring	1
5	40PB8	Piston - 4" (101.6mm) O.D. x 1" (25.4mm) I.D.	1
6	40PS1	4" (101.6mm) O.D. Piston Seal Assembly	1
7	10NU4	1" (25.4mm) - 14 N.F. Hex Nut	1
8	40HP5	Head Plate - 4" (101.6) O.D. x 2" (50.8mm) I.D. w/ Flat Head	1
9	10RS2	Rod Seal - 2-3/8" (60.2mm) O.D. x 2" (50.8mm) I.D. x 3/8" (9.39mm)	1
10	10WS6	Wiper Seal - 2-1/2" (63.5mm) O.D. x 2" (50.8mm) I.D. x 3/8" (9.39mm) - All Urethane	1

L.H. Wing Rockshaft Cylinder - 3-1/2" (88.9 mm) x 24" (610 mm) Rephasing Cylinder #305			
1	35TU15	Tube Assembly - 3-1/2" (88.9mm) x 24" (610mm)	1
2	10SH59	Shaft - 1-3/4" (44.4mm) x 24" (610mm)	1
3	10OR18	1" (25.4mm) O.D. x 7/8" (22.2mm) I.D. O-Ring	1
4	10OR8	3-1/2" (88.9mm) O.D. x 3/16" (4.76mm) O-Ring	1
5	35PB8	Piston - 3-1/2" (88.9mm) O.D. x 1" (25.4mm) I.D.	1
6	35PS1	Piston Seal Assembly	1
7	10NU4	1" (25.4mm) - 14 N.F. Hex Nut	1
8	35HP9	Head Plate - 3-1/2" (88.9mm) O.D. x 1-3/4" (44.4mm) I.D.	1
9	10RS3	Rod Seal - 1-3/4" (44.4mm) I.D. x 2-1/8" (54.0mm) O.D. x 3/8" (9.39mm)	1
10	10WS10	All Urethane Wiper Seal - 1-3/4" (44.4mm) I.D. x 2-1/8" (54.0mm) O.D. x 1/4" (6.35mm) All Urethane Wiper Seal	1

R.H. Wing Rockshaft Cylinder - 3" (76.2 mm) x 24" (610 mm) Rephasing Cylinder #304			
1	30TU34	Tube Assembly - 3" (76.2mm) x 24" (610mm)	1
2	10SH59	Shaft - 1-3/4" (44.4mm) x 24" (610mm)	1
3	10OR18	1" (25.4mm) O.D. x 7/8" (22.2mm) I.D. O-Ring	1
4	10OR3	3" (76.2mm) O.D. x 3/16" (4.76mm) O-Ring	1
5	30PB4	Piston - 3" (76.2mm) O.D. x 1" (25.4mm) I.D.	1
6	30PS1	Piston Seal Assembly	1
7	10NU4	1" (25.4mm) - 14 N.F. Hex Nut	1
8	30HP15	Head Plate - 3" (76.2mm) O.D. x 1-3/4" (44.4mm) I.D.	1
9	10RS3	Rod Seal - 1-3/4" (44.4mm) I.D. x 2-1/8" (54.0mm) O.D. x 3/8" (9.39mm)	1
10	10WS10	All Urethane Wiper Seal - 1-3/4" (44.4mm) I.D. x 2-1/8" (54.0mm) O.D. x 1/4" (6.35mm) All Urethane Wiper Seal	1
		Wiper Seal	

Wing Lift Cylinder - 5" (127 mm) x 36" (914 mm) Cylinder #242

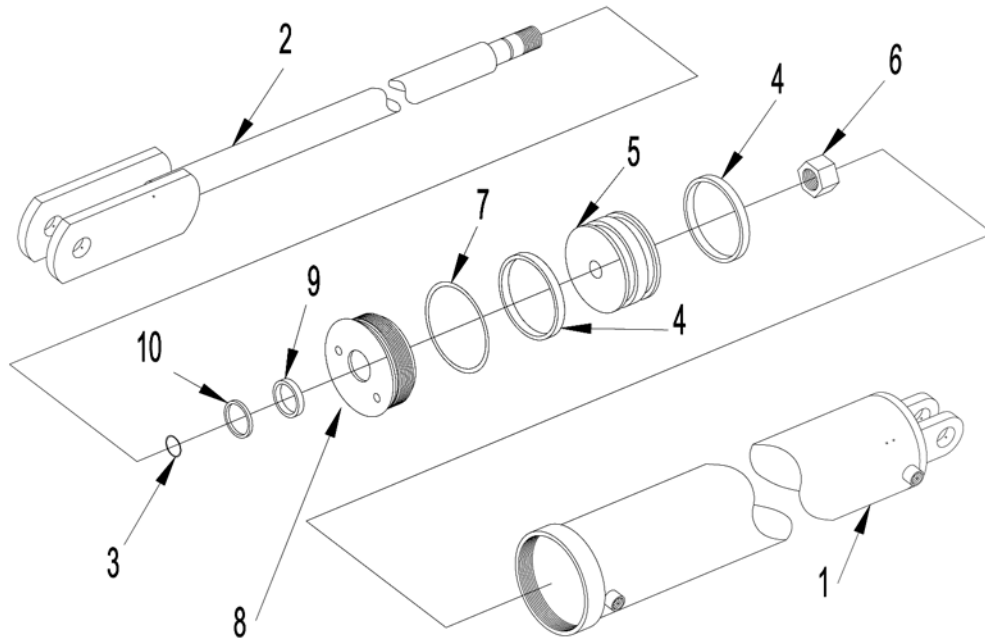

Item	Part #	Description	Qty
Wing Lift Cylinder - 5" (127 mm) x 36" (914mm) Cylinder #242			
1	50TU8	Tube Assembly - 5" (127mm) x 36" (914mm) (for cylinder #242)	1
2	10SH36	Shaft - 1-3/4" (44.4mm) x 36" (914mm) (for 1-1/4" (31.8mm) nut)	1
3	10OR19	1-1/8" (28.5mm) I.D. x 1-1/4" (31.8mm) O.D. O-Ring (for 1-1/4" (31.8mm) nut)	1
4	50CU1	4-1/2" (29.9mm) I.D. x 5" (127mm) O.D. x 1/2" (12.7mm) U-Cup	2
5	50PB2	5" (127mm) Piston (for 1-1/4" (31.8mm) nut)	1
6	10NU3	1-1/4" (31.8mm) x 12" (305mm) U.N.F. Hex Lock Nut	1
7	10OR14	4-1/2" (29.9mm) I.D. x 5" (127mm) O.D. O-Ring	1
8	50HP1	5" (127mm) Head Plate	1
9	10RS3	1-3/4" (44.4mm) I.D. x 2-1/8" (54.0mm) O.D. x 3/8" (9.39mm) Rod Seal	1
10	10WS3	1-3/4" (44.4mm) I.D. x 2-1/8" (54.0mm) O.D. x 3/16" (4.76mm) Wiper Seal	1

Item	Part #	Description	Qty
------	--------	-------------	-----

	5017N4	Seal Kit - Cylinder #242	
	50CU1	4-1/2" (114mm) I.D. x 5" (127mm) O.D. x 1/2" (12.7mm) U-Cup	2
	10OR14	4-1/2" (114mm) I.D. x 5" (127mm) O.D. O-Ring	1
	10OR19	1-1/8" (28.5mm) I.D. x 1-1/4" (31.8mm) O.D. O-Ring (1-1/4" (31.8mm) nut)	1
	10ORS3	1-3/4" (44.4mm) I.D x 2-1/8" (54.0mm) O.D. x 3/8" (9.39mm) Rod Seal	1
	10WS3	1-3/4" (44.4mm) I.D. x 2-1/8" (54.0mm) O.D. x 3/16" (4.76mm) Wiper Seal	1
	10OR13	1" (25.4mm) O.D. x 1-1/4" (31.8mm) O.D. O-Ring (1" (25.4mm) nut)	1

	4020N4-0	Seal Kit - Cylinder #306	
	10OR18	1" (25.4mm) O.D. x 7/8" (22.2mm) I.D. O-Ring	1
	10OR17	4" (101.6mm) O.D. x 3/16" (4.76mm) O-Ring	1
	40PS1	4" (101.6mm) Piston Seal Assembly	1
	10RS2	2-3/8" (60.2mm) O.D. x 2" (50.8mm) I.D. x 3/8" (9.39mm) Rod Seal	1
	10WS6	2-1/2" (63.5mm) O.D. x 2" (50.8mm) I.D. x 3/8" (9.39mm) All Urethane Wiper Seal	1

	3517N4-0	Seal Kit - Cylinder #305	
	10OR18	1" (25.4mm) O.D. x 7/8" (22.2mm) I.D. O-Ring	1
	10OR8	3-1/2" (88.9mm) O.D. x 3/16" (4.76mm) O-Ring	1
	35PS1	3-1/2" (88.9mm) Piston Seal Assembly	1
	10RS3	1-3/4" (44.4mm) I.D. x 2-1/8" (54.0mm) O.D. x 3/8" (9.39mm) Rod Seal	1
	10WS10	1-3/4" (44.4mm) I.D. x 2-1/8" (54.0mm) O.D. x 1/4" (6.35mm) All Urethane Wiper Seal	1

	3017N4-0	Seal Kit - Cylinder #304	
	10OR18	1" (25.4mm) O.D. x 7/8" (22.2mm) I.D. O-Ring	1
	10OR8	3-1/2" (88.9mm) O.D. x 3/16" (4.76mm) O-Ring	1
	35PS1	3-1/2" (88.9mm) Piston Seal Assembly	1
	10RS3	1-3/4" (44.4mm) I.D. x 2-1/8" (54.0mm) O.D. x 3/8" (9.39mm) Rod Seal	1
	10WS10	1-3/4" (44.4mm) I.D. x 2-1/8" (54.0mm) O.D. x 1/4" (6.35mm) All Urethane Wiper Seal	1

Wing Weights

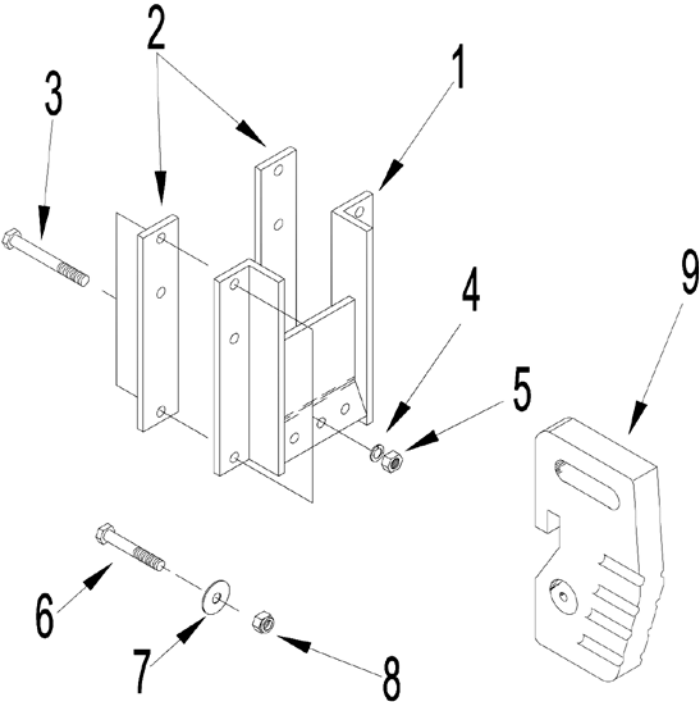

Item	Part #	Description	Qty
1	DW13547	Weight Carrier	1
2	DW13548	Backing Plate	2
3	BO62060	5/8" x 6" N.C. (15.7 x 152mm) Hex Bolt	4
4	BW062L	5/8" (15.7mm) Lockwasher	4
5	BN062	5/8" (15.7mm) Nut	4
6	BO62045	5/8" x 4-1/2" N.C. (15.7 x 114mm) Hex Bolt	3
7		5/8" I.D. (15.7mm) Flatwasher	3
8	BN062L	5/8" (15.7mm) Nylon Locknut	3
9	DW13546	78 LBS (35.4 Kg) Weight Segments	*

* as required

Delivery Checklist

Pre-delivery

- Torque all wheel bolts/lug nuts to specifications.
- Check tire pressures are correct. (Affects leveling process)
- Level machine. Refer to Operator's Manual for detailed instructions.
- Lubricate the entire machine as recommended in the Operator's Manual.
- Check tightness of all bolts.
- Check the correct # of depth stops are installed on mounting bar. (5)
*Model 81225 Offset takes (8) depth stops.
- Set front and rear gangs at medium angle.
- Adjust scrapers so they come into contact with blades.
- Check Operator's Manual to ensure all decals are correctly installed.
- Connect disc to tractor with a suitable pin and then lift the hitch jack.
- Check hydraulic hoses are leak free and hydraulic cylinders are filled with oil.
- Adjust mounted harrows as required (if equipped).
- Check overlap measurement of front gangs.
- Check opening measurement between two inner blades of rear main frame gangs.
- Check all electrical components (safety lights) and connections.
- Ensure hydraulic lockout valves function properly.

Dealer Representative:

Date:

Customer Delivery

- Give the Operator's Manual to your customer.
- Inform your customer of all safety precautions, maintenance procedures, and proper operation of the disc.
- Verify correct serial number.
- Attach disc to tractor.
- Ensure hitch jack is in transport position.
- Connect hydraulics, wiring harness, safety chain, etc.
- Ensure machine functions properly. (Fold/unfold, no leaks, lights work, etc)
- Take the disc to a field (preferably where the ground is level, if possible) and perform all required leveling adjustments. Follow the Operator's Manual.
- Explain warranty and fill out registration
- Start tractor and run all controls so your customer understands the correct operation of the disc and ensure all functions of the disc are working properly.

Dealer Representative:

Date:

Farm King Limited Warranty

This document limits your warranty rights.

Base Limited Warranty

Buhler Industries Inc. provides this warranty only to original retail purchasers of its product. Buhler Industries Inc. warrants to such purchasers that all Buhler Industries Inc. manufactured parts and components used and serviced as provided for in the Operator's Manual shall be free from defects in materials and workmanship for a period following delivery to the original retail purchaser of 12 months (80 days for commercial applications). This limited warranty applies only to those parts and components manufactured by Buhler Industries Inc. Parts and components manufactured by others are subject to their manufacturer's warranties, if any.

Buhler Industries Inc. will fulfill this limited warranty by, at its option, repairing or replacing any covered part that is defective or is the result of improper workmanship, provided that the part is returned to Buhler Industries Inc. within thirty (30) days of the date that such defect or improper workmanship is, or should have been, discovered. Buhler Industries Inc. reserves the right to either inspect the product at the buyer's location or have it returned to the factory for inspection. Parts must be returned through the selling representative and the buyer must prepay transportation charges.

Buhler Industries Inc. will not be responsible for repairs or replacements that are necessitated, in whole or part, by the use of parts not manufactured by or obtained from Buhler Industries Inc. Under no circumstances are component parts warranted against normal wear and tear. There is no warranty on product pump seals, product pump bearings, rubber product hoses, pressure gauges, or other components that require replacement as part of normal maintenance. Also: Buckets and Bucket Tines carry no warranty, Bent Spears carry no warranty, Snowblower Fan Shafts carry no warranty, Mower Blades carry no warranty, Portable Auger Parts Have Two (2) Year Warranty, Loader Parts Have Two (2) Year Warranty. The purchaser is solely responsible for determining suitability of goods sold. This warranty is expressly in lieu of all other warranties expressed or implied. Buhler Industries Inc. will in no event be liable for any incidental or consequential damages whatsoever. Nor for any sum in excess of the price received for the goods for which liability is claimed.

Repair Parts Limited Warranty

Buhler Industries Inc. warrants Farm King replacement parts purchased after the expiration of the Buhler Industries Inc. Limited Warranty, and used and serviced as provided for in the Operator's Manual, to be free from defects in materials or workmanship for a period of thirty (30) days from the invoice date for the parts. Buhler Industries Inc. will fulfill this limited warranty by, at its option, repairing or replacing any covered part that is defective or is the result of improper workmanship, provided that the part is returned to Buhler Industries Inc. within thirty (30) days of the date that such defect or improper workmanship is, or should have been, discovered. Such parts must be shipped to Buhler Industries Inc. at the purchaser's expense.

What is Not Covered

Under no circumstances does this limited warranty cover any components or parts that have been subject to the following: negligence; alteration or modification not approved by Buhler Industries Inc.; misuse; improper storage; lack of reasonable and proper maintenance, service, or repair; normal wear; damage from failure to follow operating instructions; accident; and/or repairs that have been made with parts other than those manufactured, supplied, and or authorized by Buhler Industries Inc.

Authorized Dealer and Labor Costs

Repairs eligible for labor under this limited warranty must be made by Buhler Industries Inc. or an authorized Farm King dealer. Buhler Industries Inc. retains the exclusive discretion to determine whether it will pay labor costs for warranty repairs or replacements, and the amount of such costs that it will pay and the time in which the repairs will be made. If Buhler Industries Inc. determines that it will pay labor costs for warranty work, it will do so by issuing a credit to the dealer's or distributor's account. Buhler Industries Inc. will not approve or pay invoices sent for repairs that Buhler Industries Inc. has not previously approved. Warranty service does not extend the original term of this limited warranty.

Warranty Requirements

To be covered by warranty, each Farm King new product must be registered with Buhler Industries Inc. within thirty (30) days of delivery to original retail purchaser. If the customer decides to purchase replacement components before the warranty disposition of such components is determined, Buhler Industries Inc. will bill the customer for such components and then credit the replacement invoice for those components later determined to be covered by this limited warranty. Any such replacement components that are determined not be covered by this limited warranty will be subject to the terms of the invoice and shall be paid for by the purchaser.

Warranty Claims:

Warranty requests must be prepared on Buhler Industries Inc. Warranty Claim Forms with all requested information properly completed. Warranty Claims must be submitted within a thirty (30) day period from date of failure repair.

Warranty Labor:

Any labor subject to warranty must be authorized by Buhler Industries Inc. The labor rate for replacing defective parts, where applicable, will be credited at 100% of the dealer's posted shop rate.

Exclusive Effect of Warranty and Limitation of Liability

TO THE EXTENT PERMITTED BY LAW, BUHLER INDUSTRIES INC. DISCLAIMS ANY WARRANTIES, REPRESENTATIONS, OR PROMISES, EXPRESS OR IMPLIED, AS TO THE QUALITY, PERFORMANCE, OR FREEDOM FROM DEFECT OF THE COMPONENTS AND PARTS COVERED BY THIS WARRANTY AND NOT SPECIFICALLY PROVIDED FOR HEREIN.

TO THE EXTENT PERMITTED BY LAW, BUHLER INDUSTRIES INC. DISCLAIMS ANY IMPLIED WARRANTIES OF MERCHANTABILITY AND FITNESS FOR A PARTICULAR PURPOSE ON ITS PRODUCTS COVERED HEREIN, AND DISCLAIMS ANY RELIANCE BY THE PURCHASER ON BUHLER INDUSTRIES INC.'S SKILL OR JUDGMENT TO SELECT OR FURNISH GOODS FOR ANY PARTICULAR PURPOSE. THE PURCHASER'S ONLY AND EXCLUSIVE REMEDIES IN CONNECTION WITH THE BREACH OR PERFORMANCE OF ANY WARRANTY ON PRODUCTS MANUFACTURED BY BUHLER INDUSTRIES INC. ARE THOSE SET FORTH HEREIN. IN NO EVENT SHALL BUHLER INDUSTRIES INC. BE LIABLE FOR INCIDENTAL OR CONSEQUENTIAL DAMAGES (INCLUDING, BY WAY OF EXAMPLE ONLY AND NOT LIMITATION, LOSS OF CROPS, LOSS OF PROFITS OR REVENUE, OTHER COMMERCIAL LOSSES, INCONVENIENCE, OR COST OF REPLACEMENT OF RENTAL EQUIPMENT). IN NO EVENT SHALL FARM KING'S CONTRACT OR WARRANTY LIABILITY EXCEED THE PURCHASE PRICE OF THE PRODUCT.

(Note that some provinces or states do not allow limitations on how long an implied warranty lasts or the exclusion or limitation of incidental or consequential damages, so the above limitations and exclusion may not apply to you.) This warranty gives you specific legal rights and you may also have other rights, which vary from province to province or state to state.

Buhler Industries Inc. neither assumes nor authorizes any person or entity, including its selling representatives, to assume any other obligations or liability in connections with the sale of covered equipment, or to make any other warranties, representations, or promises, express or implied, as to the quality, performance, or freedom from defect of the components and parts covered herein. No one is authorized to alter, modify, or enlarge this limited warranty, or its exclusions, limitations and reservations.

Corrections of defects and improper workmanship in the manner, and for the applicable time periods, provided for herein shall constitute fulfillment of all responsibilities of Buhler Industries Inc. to the purchaser, and Buhler Industries Inc. shall not be liable in negligence, contract, or on any other basis with respect to the subject equipment.

This limited warranty is subject to any existing conditions of supply which may directly affect Buhler Industries Inc.'s ability to obtain materials or manufacture replacement parts.

Buhler Industries Inc. reserves the right to make improvements in design or changes in specifications to its products at anytime, without incurring any obligation to owners of units previously sold.

Government Legislation:

Warranty terms and conditions are subject to provincial or state legislation.

Important Note: This warranty does not apply to rentals.

www.farm-king.com

Farm King

5110 - 62nd Street
Vegreville, Alberta Canada, T9C 1N6
Ph.: 204.822.4467 | Fax: 204.822.6348
Toll Free: 888.524.1004
E-mail: info@buhler.com
www.farm-king.com

Equipment shown is subject to change without notice.
©2011 Buhler Trading Inc. Printed in Canada TSX:BUI

bühler | a division of Buhler Industries Inc.