

Farm King

OPERATOR AND PARTS MANUAL

Rotary Cutter

Flex-Wing Models 1030 and 1530

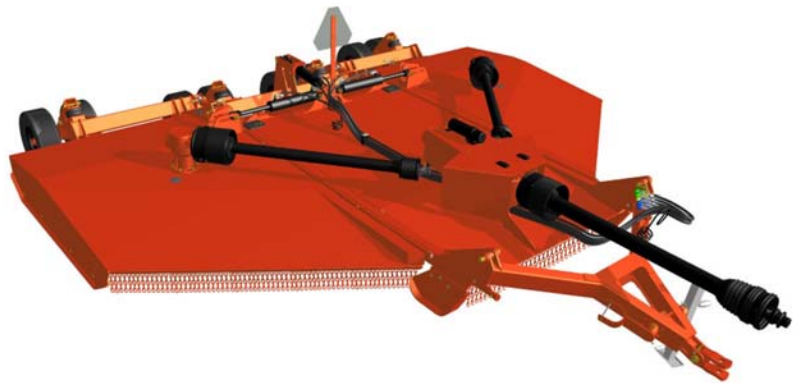

TABLE OF CONTENTS

Manufacturer’s Statement: For technical reasons, Buhler Industries Inc. reserves the right to modify machinery design and specifications provided herein without any preliminary notice. Information provided herein is of descriptive nature. Performance quality may depend on contour of ground, thickness of grass, weather conditions

INTRODUCTION 7

SAFETY13

ASSEMBLY29

OPERATION35

MAINTENANCE61

PARTS IDENTIFICATION83

SPECIFICATIONS137

WARRANTY151

ALPHABETICAL INDEX155

Farm King



WARRANTY REGISTRATION FORM

This form must be filled out by the dealer and signed by both the dealer and the customer at the time of delivery.

Customer Name:

Dealer Name:

Customer Address:

Dealer Address:

City:

Prov / State:

City:

Prov / State:

Postal / Zip Code:

Phone:

Postal / Zip Code:

Phone:

Equipment Name Model:

Serial Number:

Delivery Date:

I have thoroughly instructed the buyer on the above described equipment which review included the Operator's Manual content, equipment care, adjustments, safe operation and applicable warranty policy.

Dealer Inspection Report

- Gearbox Oil Level
- Lubricate Machine
- Wheel Bolt Torque
- Fasteners Tight
- Adjustment Link
- Hydraulic Hoses
- Electrical Harnesses (If Equipped)
- Tire Pressure

Safety

- All Lights And Reflectors Installed
- All Lights And Reflectors Cleaned And Working
- Safety Chain On Hitch
- All Decals Installed
- Guards And Shields Installed And Secure
- Review Operating And Safety Instructions
- General Adjustment And Set-up Procedures
- Transportation Requirements And Regulations

Date:

Dealer Rep. Signature:

The above equipment and Operator And Parts Manual have been received by me and I have been thoroughly instructed as to care, adjustments, safe operation and applicable warranty policy.

Date:

Customer / Owner's Signature:

Remove this Warranty Registration Form from the Operator And Parts Manual. Make two copies of the form. Send original Warranty Registration Form to Farm King. Give one copy to the customer and the dealer will keep one copy.

Farm King



INTRODUCTION

This Operator And Parts Manual was written to give the owner / operator instructions on the safe operation, maintenance and part identification of the Farm King equipment. **READ AND UNDERSTAND THIS OPERATOR AND PARTS MANUAL BEFORE OPERATING YOUR FARM KING EQUIPMENT.** If you have any questions, see your Farm King dealer. This manual may illustrate options and accessories not installed on your Farm King equipment.

OWNER'S INFORMATION 9

 Serial Number Location 9

 Manual Storage 9

EQUIPMENT IDENTIFICATION10

 1030 Component Location10

 1530 Component Location11

Farm King



OWNER’S INFORMATION

Thank you for your decision to purchase a Farm King Rotary Cutter. To ensure maximum performance of your equipment, it is mandatory that you thoroughly study the Operator And Parts Manual and follow the recommendations. Proper operation and maintenance are essential to maximize equipment life and prevent personal injury.

Operate and maintain this equipment in a safe manner and in accordance with all applicable local, state, and federal codes, regulations and / or laws. Follow all on-product labeling and instructions.

Make sure that all personnel have read this Operator and Parts Manual and thoroughly understand safe and correct operating, installation and maintenance procedures.

Farm King is continually working to improve its products. Farm King reserves the right to make any improvements or changes as deemed practical and possible without incurring any responsibility or obligation to make any changes or additions to equipment sold previously.

Although great care has been taken to ensure the accuracy of this publication, Farm King makes no warranty or guarantee of any kind, written or expressed, implied or otherwise with regard to the information contained within this manual. Farm King assumes no responsibility for any errors that may appear in this manual and shall not be liable under any circumstances for incidental, consequential or punitive damages in connection with, or arising from the use of this manual.

Keep this manual available for frequent reference. All new operators or owners must review the manual before using the equipment and annually thereafter. Contact your Farm King Dealer if you need assistance, information, or additional copies of the manual. Visit our website at www.farm-king.com for a complete list of dealers in your area.

The directions left, right, front and rear, as mentioned throughout this manual, are as viewed from the rear of the equipment.

Serial Number Location

Please enter the model and serial number in the space provided for easy reference.

Figure 1

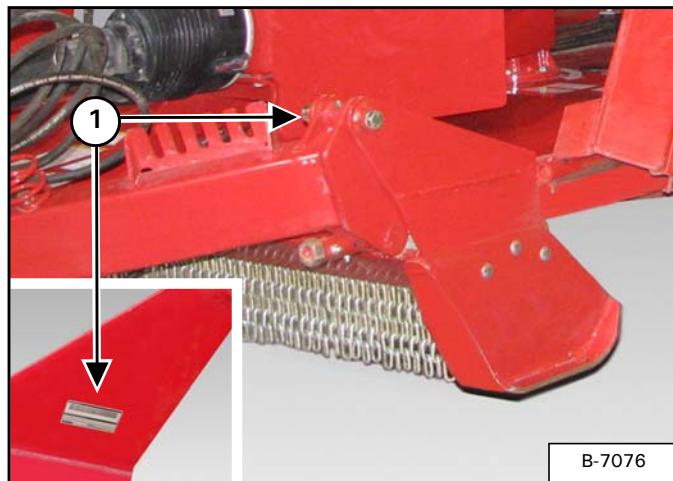

Model Number: _____

Serial Number: _____

The serial number plate (Item 1) [Figure 1] is located on the inside of the left hitch mounting plate.

Always use your serial number when requesting information or when ordering parts.

Manual Storage

Figure 2

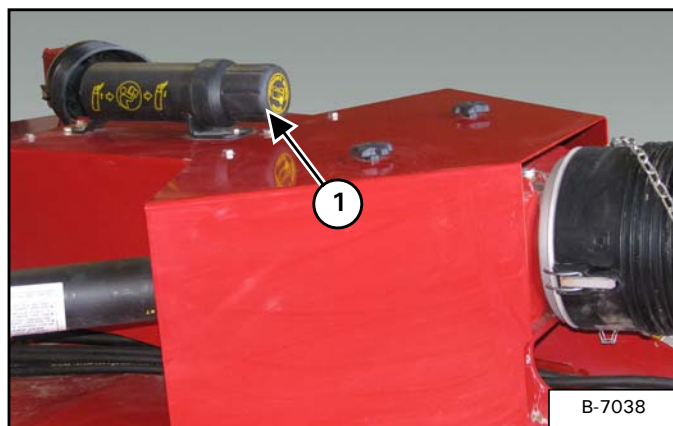

The Operator And Parts Manual and other documents can be stored in the canister (Item 1) [Figure 2] located on the top of the splitter gearbox guard.

EQUIPMENT IDENTIFICATION

1030 Component Location

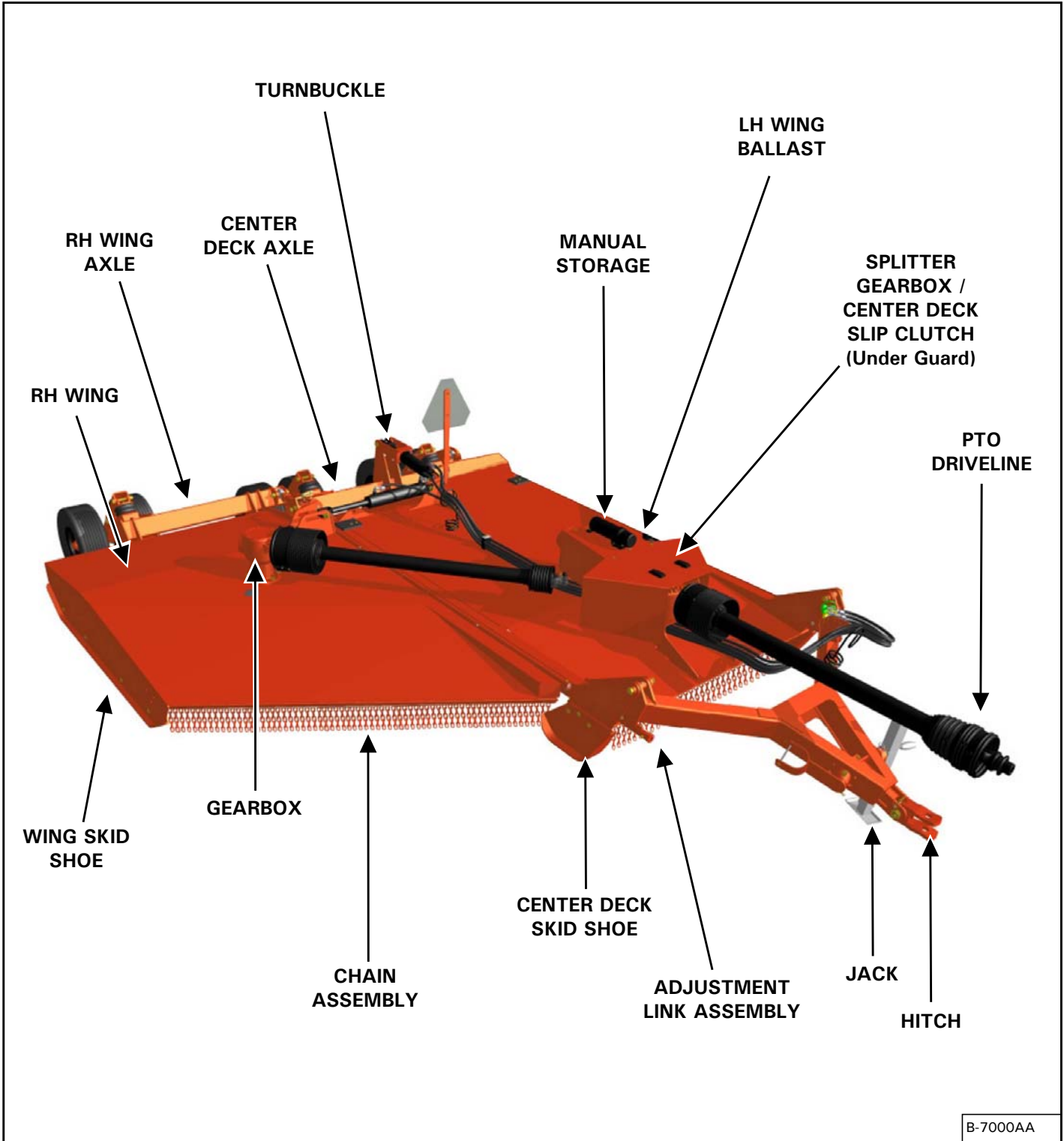

1530 Component Location

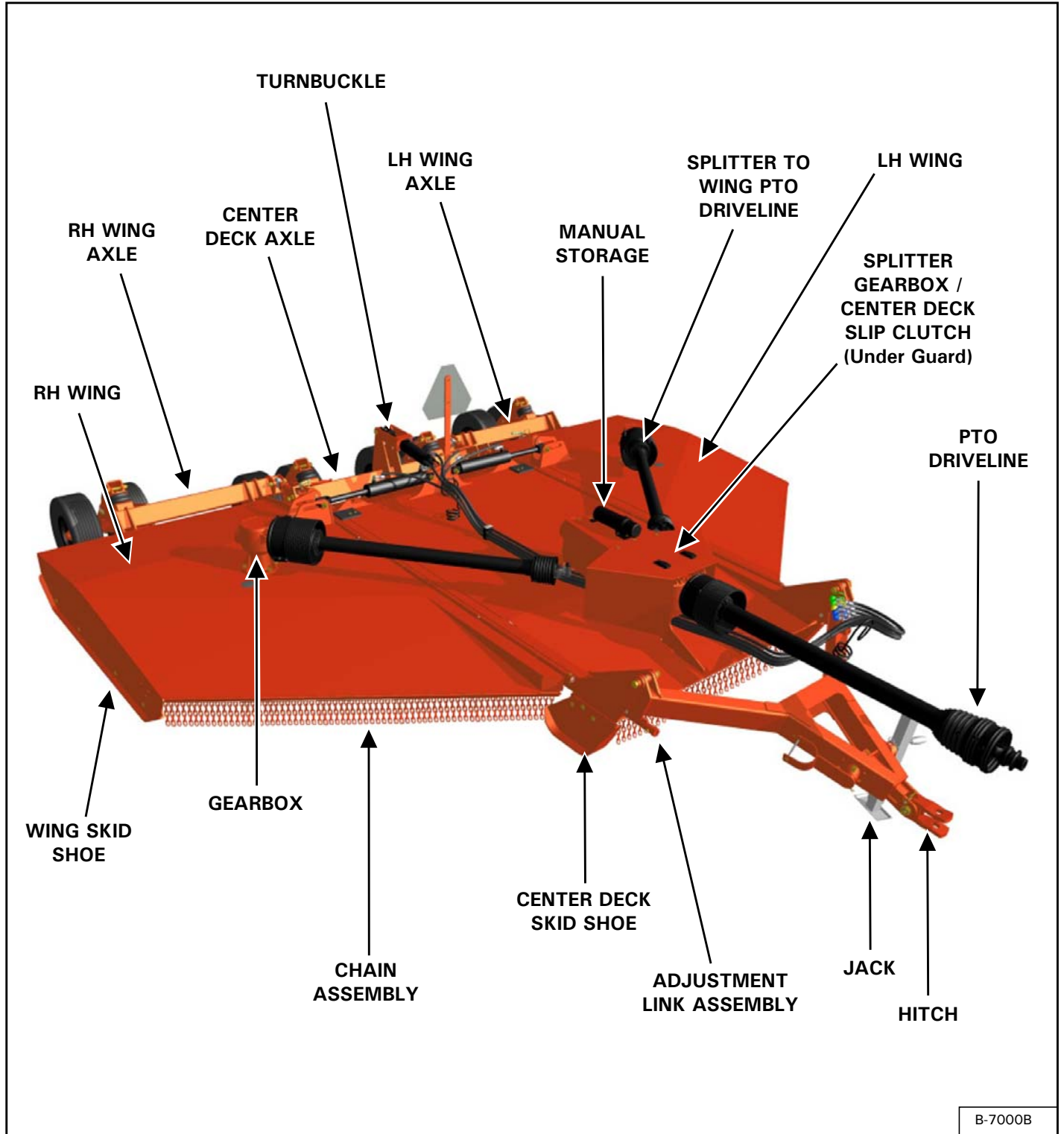

Farm King



SAFETY

SAFETY INSTRUCTIONS15

- Safe Operation Is The Operator’s Responsibility15
- Safe Operation Needs A Qualified Operator15
- Use Safety Rules16
- Transport Safety16
- Safety Rules For Power Take-Off (PTO) Driven Equipment17
- Machine Requirements And Capabilities17

FIRE PREVENTION18

- Maintenance18
- Operation18
- Starting18
- Electrical18
- Hydraulic System18
- Fueling18
- Spark Arrester Exhaust System18
- Welding And Grinding19
- Fire Extinguishers19

SAFETY SIGNS (DECALS)20

EQUIPMENT DECALS AND SIGNS26

SAFETY SIGN-OFF FORM27

Farm King



SAFETY INSTRUCTIONS

Safe Operation Is The Operator’s Responsibility

	<p>Safety Alert Symbol</p>
<p>This symbol with a warning statement means: “Warning, be alert! Your safety is involved!” Carefully read the message that follows.</p>	



CAUTION

The signal word **CAUTION** on the machine and in the manuals indicates a potentially hazardous situation which, if not avoided, may result in minor or moderate injury. It may also be used to alert against unsafe practices.



DANGER

The signal word **DANGER** on the machine and in the manuals indicates a hazardous situation which, if not avoided, will result in death or serious injury.



WARNING

The signal word **WARNING** on the machine and in the manuals indicates a potentially hazardous situation which, if not avoided, could result in death or serious injury.



IMPORTANT

This notice identifies procedures which must be followed to avoid damage to the machine.

Safe Operation Needs A Qualified Operator



WARNING

Operators must have instructions before operating the machine. Untrained operators can cause injury or death.

For an operator to be qualified, he or she must not use drugs or alcoholic drinks which impair alertness or coordination while working. An operator who is taking prescription drugs must get medical advice to determine if he or she can safely operate a machine and the equipment.

A Qualified Operator Must Do The Following:

Understand the Written Instructions, Rules and Regulations

- The written instructions from Farm King include the Warranty Registration, Dealer Inspection Report, Operator And Parts Manual and machine signs (decals).
- Check the rules and regulations at your location. The rules may include an employer’s work safety requirements. Regulations may apply to local driving requirements or use of a Slow Moving Vehicle (SMV) emblem. Regulations may identify a hazard such as a utility line.

Have Training with Actual Operation

- Operator training must consist of a demonstration and verbal instruction. This training is given by the machine owner prior to operation.
- The new operator must start in an area without bystanders and use all the controls until he or she can operate the machine safely under all conditions of the work area. Always fasten seat belt before operating.

Know the Work Conditions

- Clear working area of all bystanders, especially small children and all obstacles that might be hooked or snagged, causing injury or damage.
- Know the location of any overhead or underground power lines. Call local utilities and have all underground power lines marked prior to operation.
- Wear tight fitting clothing. Always wear safety glasses when doing maintenance or service.

SAFETY INSTRUCTIONS (CONT'D)**Use Safety Rules**

- Read and follow instructions in this manual and the tractor's Operators Manual before operating.
- Under no circumstances should young children be allowed to work with this equipment.
- This equipment is dangerous to children and persons unfamiliar with its operation.
- If the elderly are assisting with work, their physical limitations need to be recognized and accommodated.
- Stay clear of overhead power lines when lowering or raising the wings. Electrocutation can occur without direct contact.
- Check for overhead and / or underground lines before operating equipment (if applicable).
- In addition to the design and configuration of equipment, hazard control and accident prevention are dependent upon the awareness, concern, prudence and proper training of personnel involved in the operation, transport, maintenance and storage of equipment.
- Check that the equipment is securely fastened to the tractor / towing vehicle.
- Make sure all the machine controls are in the NEUTRAL position before starting the machine.
- Operate the equipment only from the operator's position.
- Operate the equipment according to the Operator And Parts Manual.
- When learning to operate the equipment, do it at a slow rate in an area clear of bystanders, especially small children.
- DO NOT permit personnel to be in the work area when operating the equipment.
- The equipment must be used ONLY on approved tractors / transport vehicles.
- DO NOT modify the equipment in any way. Unauthorized modification may impair the function and / or safety and could affect the life of the equipment.
- DO NOT make any adjustments or repairs on the equipment while the machine is running.
- Keep shields and guards in place. Replace if damaged.

- Operate only with tractor equipped with ROPS (Roll Over Protective System) and seatbelts.
- DO NOT drive into or out of a ditch or on a steep incline with wings in raised position.
- Decrease speed when turning, be careful on slopes or uneven terrain with wings in raised position.
- DO NOT operate rotary cutter in poor visibility conditions such as fog, darkness, or any conditions that limit clear visibility less than 300 feet (100 m) in front of and to the sides of the rotary cutter.
- When conditions make it necessary to slow ground speed, shift to a lower gear rather than reducing engine speed. The engine will maintain rated speed and keep cutter running at optimum cutting speed.
- DO NOT operate in a work area that has not been inspected for foreign debris and obstacles.
- Remove any foreign objects and clearly mark any objects that cannot be removed.

Transport Safety

- Do not exceed 20 mph (32 kph). Reduce speed on rough roads and surfaces.
- Comply with state and local laws governing highway safety and movement of machinery on public roads.
- The use of flashing amber lights is acceptable in most localities. However, some localities prohibit their use. Local laws should be checked for all highway lighting and marking requirements.
- Always install transport locks, pins or brackets before transporting (if applicable).
- Always yield to oncoming traffic in all situations and move to the side of the road so any following traffic may pass.
- Always enter curves or drive up or down hills at a low speed and at a gradual steering angle.
- Never allow riders on either tractor or equipment.
- Keep tractor / towing vehicle in a lower gear at all times when traveling down steep grades.
- Maintain proper brake settings at all times (if equipped).
- Stay away from overhead power lines when lowering or raising the wings. Electrocutation can occur without direct contact.

Safety Rules For Power Take-Off (PTO) Driven Equipment

- Keep PTO shields and all guards in place. Replace damaged or missing shields and guards before operating.
- Follow warnings and instructions on machine signs (decals). Replace damaged or missing decals.
- Do not wear loose or bulky clothing around the PTO or other moving parts.
- Keep bystanders away from PTO driven equipment, and never allow children near machines.
- Read and understand the manuals for the PTO driven equipment and be aware of safe operating procedures and hazards that may not be readily apparent.
- Always walk around equipment to avoid coming near a turning PTO driveline. Stepping over, leaning across or crawling under a turning PTO driveline can cause entanglement.
- Position the machine and equipment hitch correctly to prevent driveline stress and separation.
- Use caution when turning. Turning too sharp can cause driveline damage.
- Use caution when raising PTO driven attachment. Excessive driveline angle can cause driveline damage. Use stops if needed.

Machine Requirements And Capabilities

- Fasten seat belt securely. If equipped with a foldable Roll-Over Protective Structure (ROPS), only fasten seat belt when ROPS is up and locked. DO NOT wear seat belt if ROPS is down.
- Machine's three-point hitch must be equipped with sway bars or chains.
- Stop the machine and engage the parking brake. Install blocks in front of and behind the rear tires of the machine. Install blocks underneath and support the equipment securely before working under raised equipment.
- Keep bystanders clear of moving parts and the

work area. Keep children away.

- Use increased caution on slopes and near banks and ditches to prevent overturn.
- Make certain that the Slow Moving Vehicle (SMV) emblem is installed so that it is visible and legible. When transporting the equipment, use the flashing warning lights (if equipped) and follow all local regulations.
- Operate this equipment with a machine equipped with an approved Roll-Over Protective Structure (ROPS). Always wear seat belt when the ROPS is up. Serious injury or death could result from falling off the machine.
- Before leaving the operator's position:
 1. Always park on a flat level surface.
 2. Place all controls in neutral.
 3. Engage the parking brake.
 4. Stop engine.
 5. Wait for all moving parts to stop.
- Carry passengers only in designated seating areas. Never allow riders on the machine or equipment. Falling off can result in serious injury or death.
- Start the equipment only when properly seated in the operator's seat. Starting a machine in gear can result in serious injury or death.
- Operate the machine and equipment from the operator's position only.
- The parking brake must be engaged before leaving the operator's seat. Rollaway can occur because the transmission may not prevent machine movement.

FIRE PREVENTION



Maintenance

The machine and some equipment have components that are at high temperatures under normal operating conditions. The primary source of high temperatures is the engine and exhaust system. The electrical system, if damaged or incorrectly maintained, can be a source of arcs or sparks.

Flammable debris (leaves, straw, etc.) must be removed regularly. If flammable debris is allowed to accumulate, it can cause a fire hazard. Clean often to avoid this accumulation. Flammable debris in the engine compartment is a potential fire hazard.

The operator’s area, engine compartment and engine cooling system must be inspected every day and cleaned if necessary to prevent fire hazards and overheating.

All fuels, most lubricants and some coolant mixtures are flammable. Flammable fluids that are leaking or spilled onto hot surfaces or onto electrical components can cause a fire.

Operation

The Farm King machine must be in good operating condition before use.

Check all of the items listed on the service schedule under the 8 hour column. (See “SERVICE SCHEDULE” on page 65.)

Do not use the machine where exhaust, arcs, sparks or hot components can contact flammable material, explosive dust or gases.

Starting

Do not use ether or starting fluids on any engine that has glow plugs. These starting aids can cause explosion and injure you or bystanders.

Use the procedure in the tractor’s operator’s manual for connecting the battery and for jump starting.

Electrical



Check all electrical wiring and connections for damage. Keep the battery terminals clean and tight. Repair or replace any damaged part or wires that are loose or frayed.

Battery gas can explode and cause serious injury. Do not jump start or charge a frozen or damaged battery. Keep any open flames or sparks away from batteries. Do not smoke in battery charging area.

Hydraulic System

Check hydraulic tubes, hoses and fittings for damage and leakage. Never use open flame or bare skin to check for leaks. Hydraulic tubes and hoses must be properly routed and have adequate support and secure clamps. Tighten or replace any parts that show leakage.

Always clean fluid spills. Do not use gasoline or diesel fuel for cleaning parts. Use commercial nonflammable solvents.

Fueling



Stop the engine and let it cool before adding fuel. No smoking! Do not refuel a machine near open flames or sparks. Fill the fuel tank outdoors.

Spark Arrester Exhaust System

The spark arrester exhaust system is designed to control the emission of hot particles from the engine and exhaust system, but the muffler and the exhaust gases are still hot.

Check the spark arrester exhaust system regularly to make sure it is maintained and working properly. Use the procedure in the machine’s Operator’s Manual for cleaning the spark arrester muffler (if equipped).

FIRE PREVENTION (CONT'D)**Welding And Grinding**

Always clean the machine and equipment, disconnect the battery, and disconnect the wiring from the machine controls before welding. Cover rubber hoses, battery and all other flammable parts. Keep a fire extinguisher near the machine when welding.

Have good ventilation when grinding or welding painted parts. Wear dust mask when grinding painted parts. Toxic dust or gas can be produced.

Dust generated from repairing nonmetallic parts such as hoods, fenders or covers can be flammable or explosive. Repair such components in a well ventilated area away from open flames or sparks.

Fire Extinguishers

Know where fire extinguishers and first aid kits are located and how to use them. Inspect the fire extinguisher and service the fire extinguisher regularly. Obey the recommendations on the instructions plate.

SAFETY SIGNS (DECALS)

Follow the instructions on all the Signs (Decals) that are on the equipment. Replace any damaged signs (decals) and be sure they are in the correct locations. Equipment signs are available from your Farm King equipment dealer.

Left Rear Corner Of LH Deck



Right Rear Corner Of RH Deck



1



p/n 919272

2



p/n 918276

Rear Center Deck



1

2

DANGER

**FALLING WING
CAN CAUSE SERIOUS INJURY
OR DEATH**

- Always secure wing transport locks before transporting, servicing, or parking the cutter.
- Stand clear when lowering or raising wings.

918275

p/n 918275

WARNING

**CRUSHING HAZARD
CAN CAUSE SERIOUS INJURY
OR DEATH**

- Engage transport locks.
- Block up before servicing.
- Purge air from hydraulic system before attempting to raise or lower implement.

918279

p/n 918279

3

DANGER

Engage frame lock bracket and retainer before transporting, storing or working under frame to prevent machine from falling down and crushing someone.

919274

p/n 919274

Rear Of Hitch (1030)

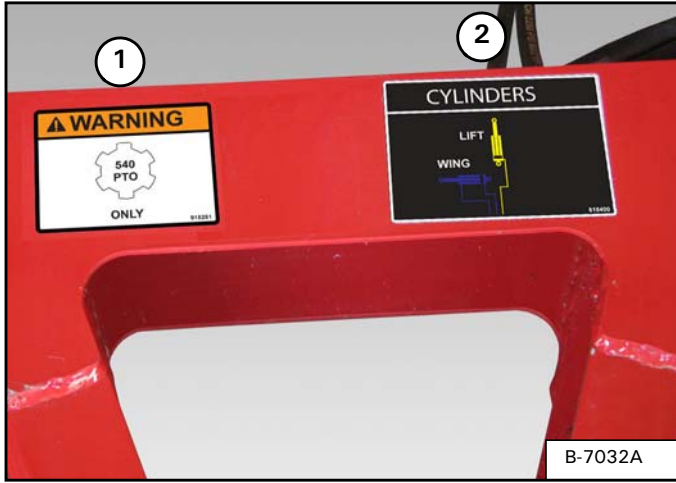

Rear Of Hitch (1530)

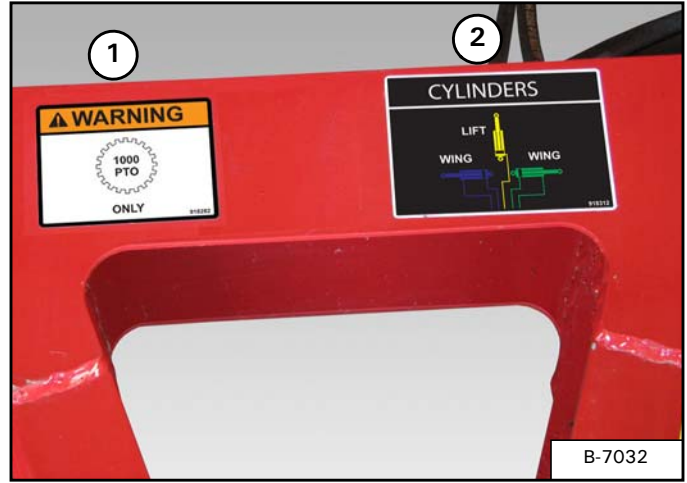

1



p/n 918281

1



p/n 918282

2

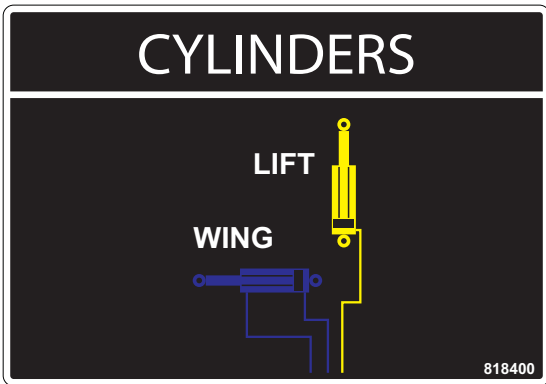

p/n 818400

2

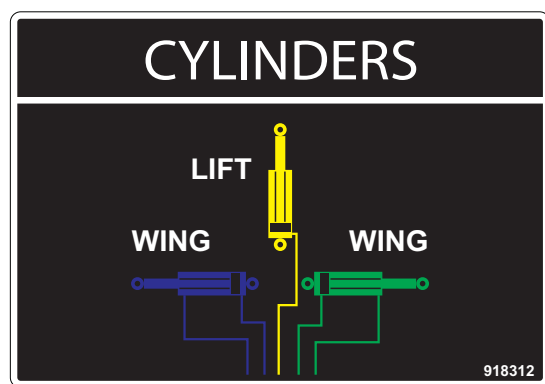

p/n 918312

Splitter Gearbox Guard / Shield



Under Splitter Gearbox Guard / Shield

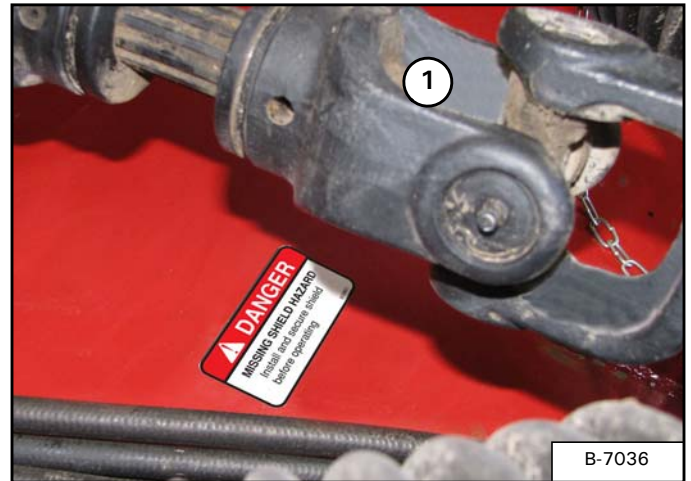

①



p/n 918272

①



p/n 915861

Right Side Splitter Gearbox Guard / Shield (Model 1030, 1530)

1

CAUTION

An OPERATOR'S MANUAL and a WARRANTY REGISTRATION CARD were attached to this implement during final assembly at the factory. If they were not attached at the time of purchase, please contact the selling dealer at once.

-Read and understand the Manual before operating the implement.

-Complete, sign and mail in the Warranty Registration Card immediately.

919219

p/n 919219

2

CAUTION

1. Read and understand Operator's Manual. Review annually.
2. Always keep bystanders and co-workers a minimum of 300 ft (100 m) away.
3. Perform routine inspections and corrective/preventative maintenance. Keep all shields and guards in place.
4. Operate only with tractor equipped with ROPS and seatbelts.
5. Before leaving seat: Set brake, stop engine, remove key, and wait until all moving parts have stopped.
6. Always inspect the area before cutting. Remove all foreign debris.
7. Never allow riders, especially children, on tractor or equipment.
8. Stay clear of rotating or moving parts.
9. Never allow the cutter blades to contact solid objects or foreign materials.
10. Inspect blades daily for chips, cracks, wear, and abnormal bends. Unbalanced blades are dangerous. Replace damaged blades in pairs with genuine Farm King blades only.
11. Do not operate with wings above specified operating position. See Operator's Manual for wing operating range.
12. Purge all air from hydraulic system before attempting to raise or lower this implement.
13. Lower the implement and relieve pressure before working on hydraulic system. Use a piece of cardboard or wood when searching for leaks.
14. Securely block up implement on firm ground before working beneath unit.
15. Transport with clean reflectors, SMV, and working lights as required by federal, provincial/state, and local laws.
16. Ensure transport safety chain and all hitch components are secure and in proper working order at all times.
17. Engage all safety locks before transporting.
18. Decrease speed when turning, be careful on slopes or uneven terrain with wings in raised position.
19. Keep mower deck clear of debris. There is a risk of fire if too much debris accumulates.
20. Do not transport above speeds of 20 mph (32 km/h). Exceeding these speeds may result in loss of control.
21. Do not operate in raised position. Objects may be thrown under guards.

918283

p/n 918283

3 1 2

4 5

B-7101

3

WARNING

HIGH PRESSURE FLUID CAN PIERCE SKIN CAUSING SERIOUS INJURY OR DEATH

-Relieve pressure on system before repairing or adjusting.
-Wear proper hand and eye protection when searching for leaks. Use wood or cardboard instead of hands.
-Keep all components in good repair.

918280

p/n 918280

4

WARNING

ROLL OVER HAZARD CAN CAUSE SERIOUS INJURY OR DEATH

-Decrease speed when turning.
-Be careful on slopes with wings raised.
-Do not operate with raised wings.

918278

p/n 918278

5

DANGER

DAMAGED BLADES CAN CAUSE SERIOUS INJURY OR DEATH

-Inspect blades daily for chips, cracks, wear and abnormal bends.
-Replace blades with genuine Farm King blades only.
-Unbalanced blades are dangerous. Replace blades in pairs.

918277

p/n 918277

Left Side Splitter Gearbox Guard / Shield (Model 1030, 1530)

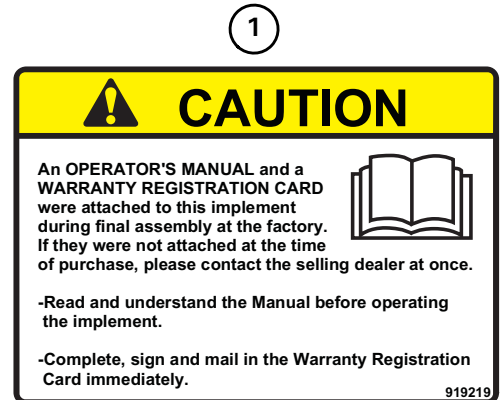
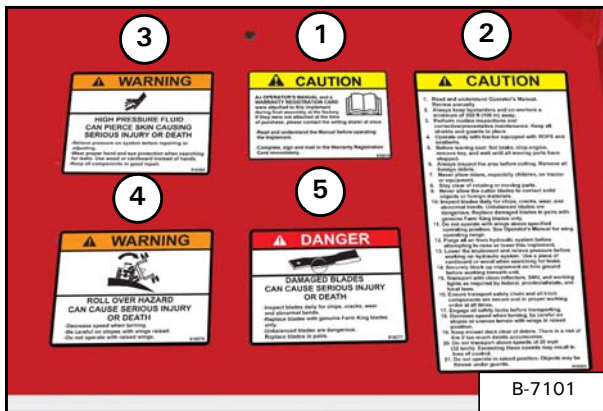

p/n 919219

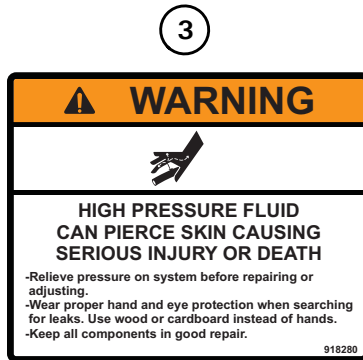

p/n 918280



p/n 918278



p/n 918277

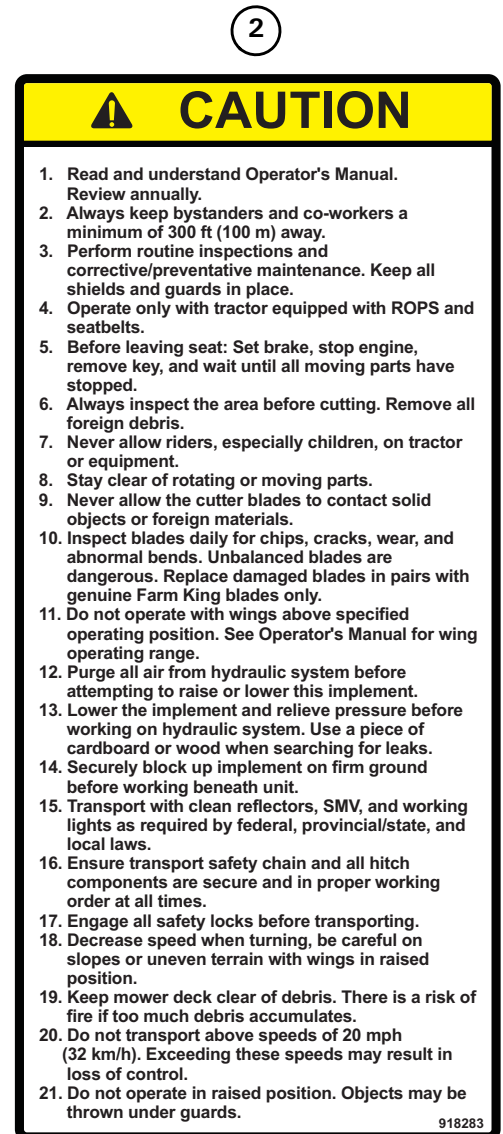

p/n 918283

EQUIPMENT DECALS AND SIGNS

NOTE: All safety related decals are shown in the Safety Signs Section. (See "SAFETY SIGNS (DECALS)" on page 20.)

Check and replace any worn, torn, hard to read or missing decals on your equipment.

Part Number 926844

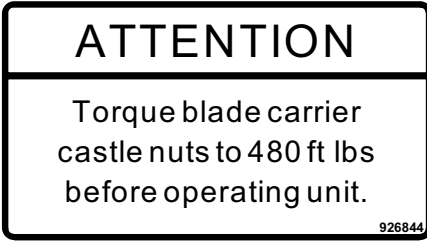

Part Number 918298

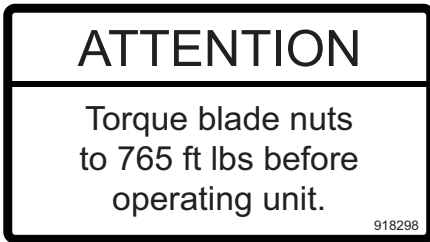

Part Number 918406

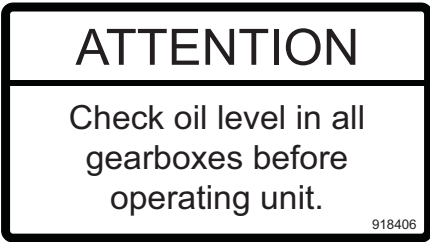

Part Number 967055 (Amber)



Part Number 967053 (Red)



Part Number 918312 - 1530 Model

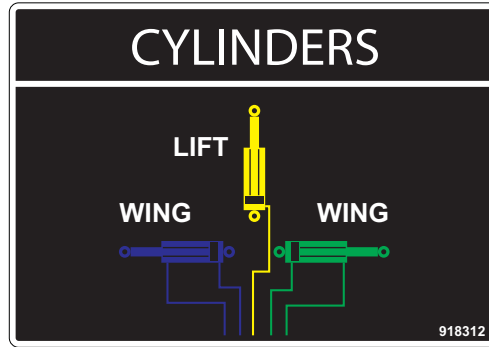

Part Number 818400 - 1030 Model

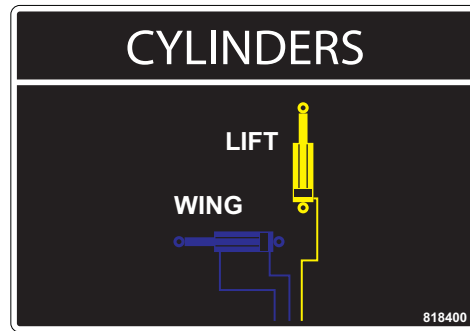

Part Number 918292

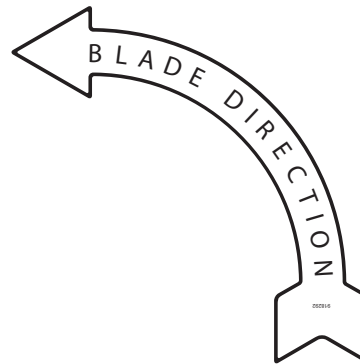

Part Number 918293

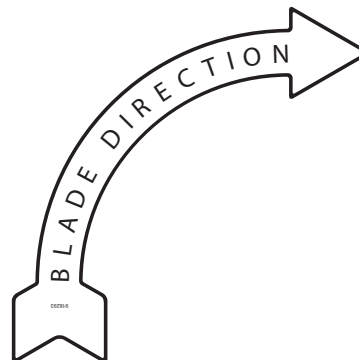

Farm King



ASSEMBLY

LIGHT KIT INSTALLATION31
 Dimensions31
 Procedure32

Farm King



LIGHT KIT INSTALLATION

Dimensions

Figure 3

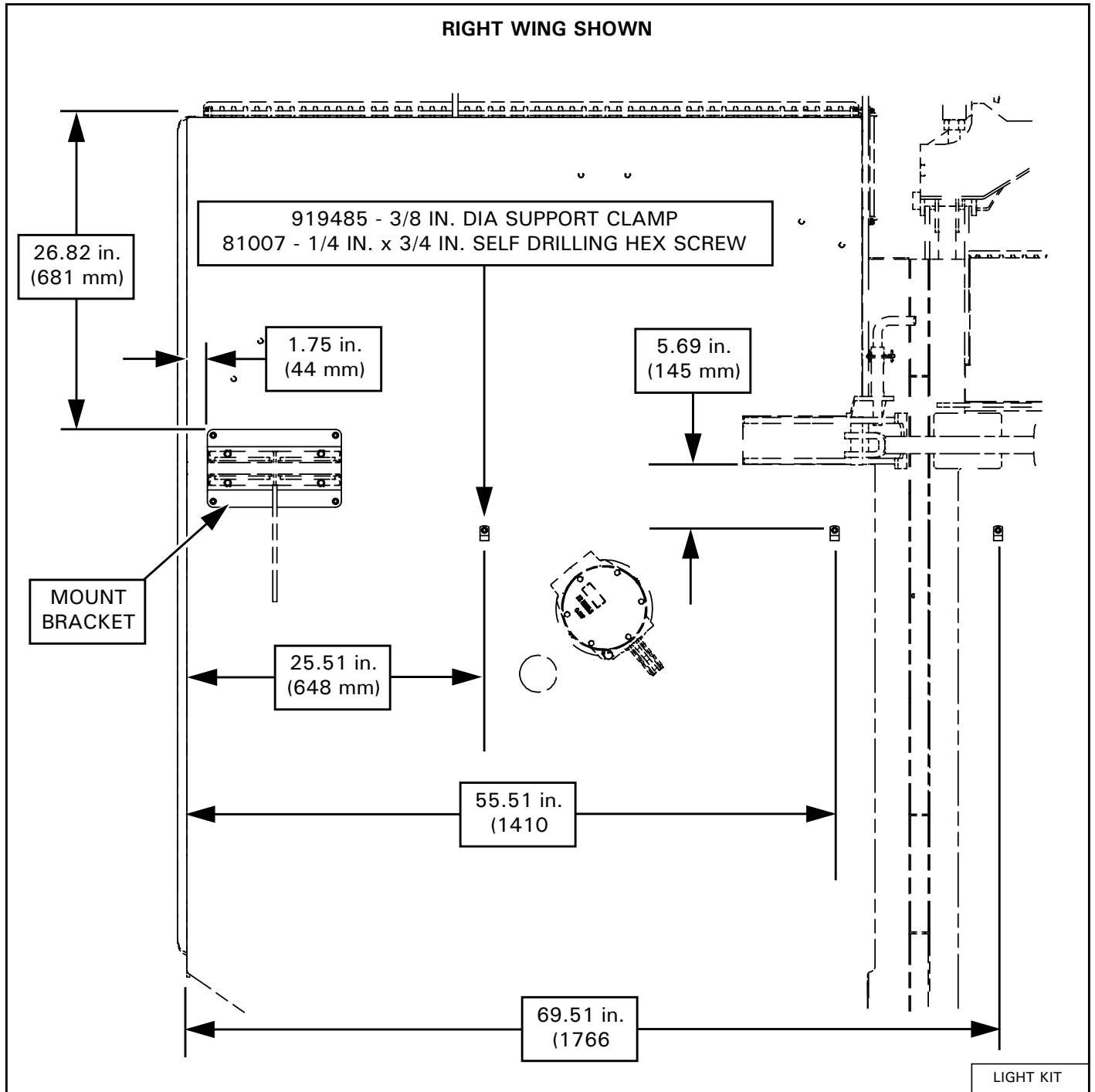

Using the dimensions [Figure 3], measure and mark the locations where individual light kit components will be installed.

Procedure

NOTE: The following images show installing the RH tail lamp / warning lamp light. The procedure is the same for the LH tail lamp / warning lamp light.

Figure 4

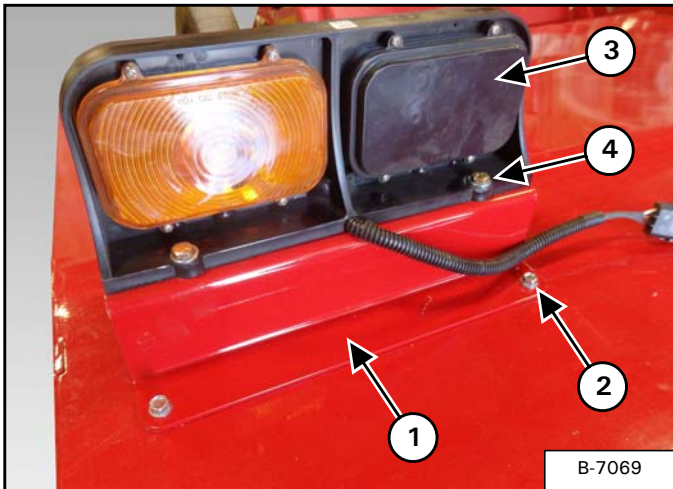

Place the tail lamp mount bracket (Item 1) [Figure 4] at the pre measured / marked location on the RH wing.

Install one 1/4" x 3/4" self drilling screw (Item 2) [Figure 4] through the tail lamp mount bracket and into the RH wing deck (four locations).

Place the RH tail lamp / warning lamp light (Item 3) [Figure 4] onto the tail lamp mount bracket (amber light to the outside).

Install one 1/4" flat washer onto four 1/4" x 1" bolts (Item 4) [Figure 4]. Install the four bolts through the RH tail lamp / warning lamp light and tail lamp mount bracket. Install one 1/4" lock nut on each of the four bolts. Tighten bolts and lock nuts to secure the RH tail lamp / warning lamp light to the tail lamp mount bracket.

Model 1530 Only

Repeat procedure to install the LH tail lamp / warning lamp light and tail lamp mount bracket.

Figure 5

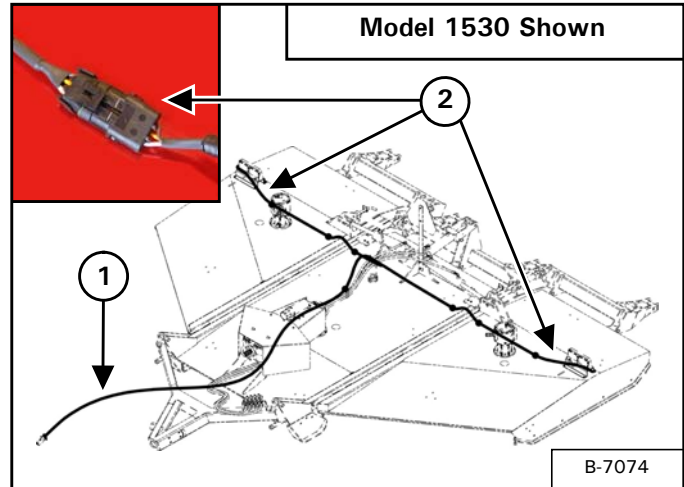

Route the wire harness (Item 1) [Figure 5] to the front of the Rotary Cutter with hydraulic hoses and to the RH & LH tail lamp / warning lamp lights.

Connect the wire harness (as needed) to the RH & LH tail lamp / warning lamp light pig tails (Item 2) [Figure 5].

Figure 6

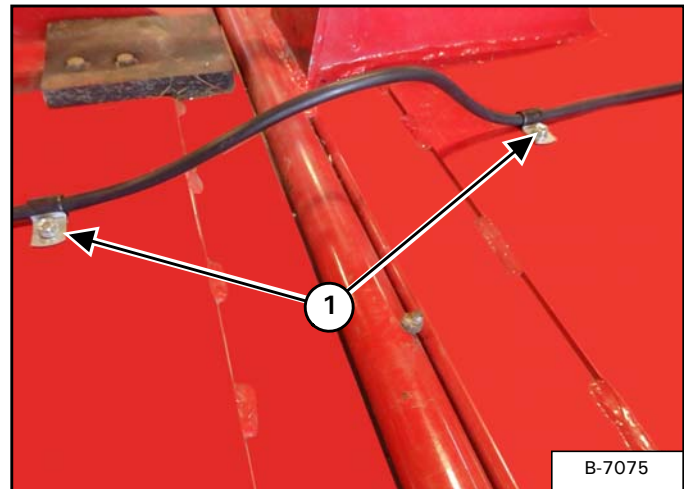

Install the 3/8" clamps (Item 1) [Figure 6] around the wire harness at the pre measured / marked locations.

Secure 3/8" clamps to the center section and wings using 1/4" x 3/4" self drilling screws.

NOTE: Before securing the 3/8" clamps to Rotary Cutter, make sure to leave a loop in the wire harness to allow wings to fold / unfold without damaging the wire harness

Figure 7

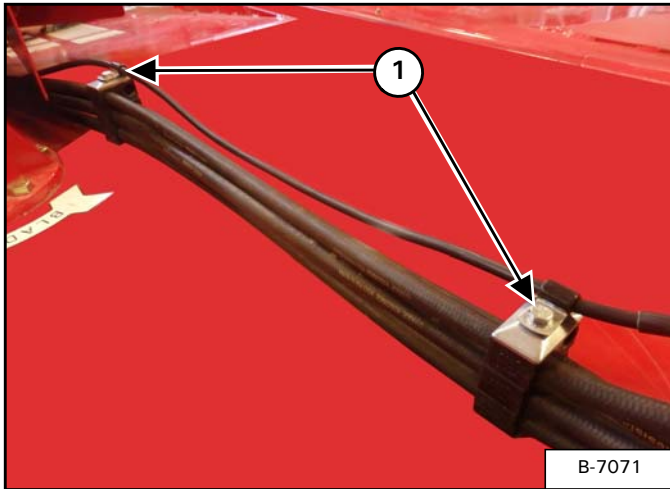

Remove bolts (Item 1) [Figure 7] on the hydraulic hose clamps. Place a 3/8" clamp around the wire harness and along with hydraulic hose clamp hole. Re-install the bolt (all locations to the front).

Figure 8

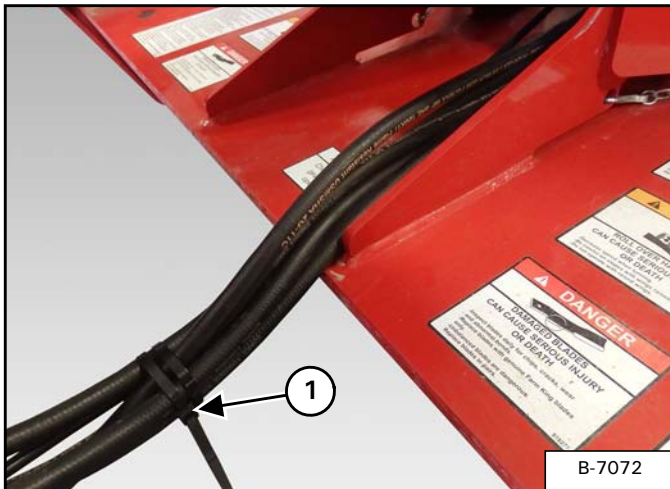

Install cable ties (Item 1) [Figure 8] around the hydraulic hoses and wire harness as needed.

Figure 9

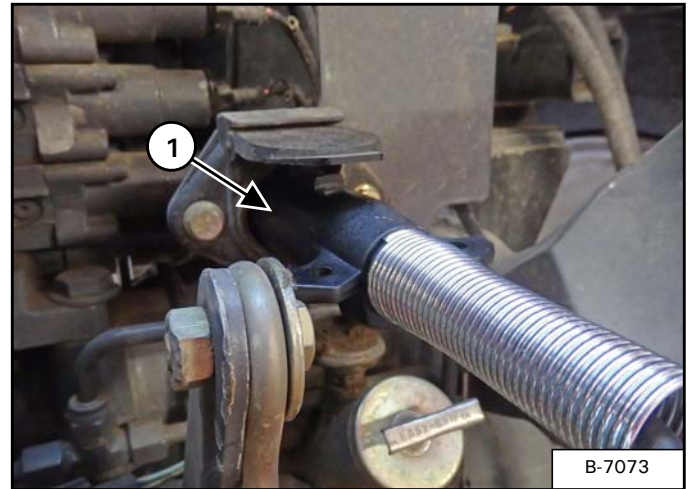

Connect the wire harness (Item 1) [Figure 9] to the tractor.

Test the RH & LH tail lamp / warning lamp lights for correct operation.

Farm King



OPERATION

GENERAL INFORMATION37
 Pre - Operation Checklist37
 Break - In Checklist38
 Tractor Requirements38
 Entering And Leaving The Operator’s Position39

INITIAL SET-UP40
 Frame Lock40
 Wing Transport Locks41
 Connecting The Rotary Cutter To The Tractor42
 Connecting The PTO Driveline44
 PTO Driveline45
 Connecting Hydraulic Hoses48
 Purging The Hydraulic System49

PRE OPERATION49
 Recommended Deck Height49
 Leveling The Center Deck50
 Leveling The RH & LH Wings51

OPERATING THE ROTARY CUTTER53
 Cutting Procedure53
 Wing Float Position55
 Cutting Angles56
 Cutting Recommendations57

TRANSPORTING58
 Requirements58
 Transporting Guidelines58
 Transporting Procedure59

Farm King



GENERAL INFORMATION

Pre - Operation Checklist

Before operating the Rotary Cutter for the first time and each time thereafter, check the following items:



AVOID INJURY OR DEATH

- Disengage the PTO, engage the machine’s parking brake, stop the engine and make sure all rotating components are completely stopped before connecting, disconnecting, adjusting or cleaning any PTO driven equipment.
- Always keep PTO shields and all guards in place when using PTO driven equipment.
- Disengage PTO for road travel.
- Keep hands, feet and clothing away.



AVOID INJURY OR DEATH

Wear safety glasses to prevent eye injury when any of the following conditions exist:

- When fluids are under pressure.
 - Flying debris or loose material is present.
 - Engine is running.
 - Tools are being used.
-
1. Lubricate the equipment per the schedule outline in the Maintenance Section. (See “SERVICE SCHEDULE” on page 65.)
 2. Check the rotary cutter hitch for damaged, loose or missing parts. Repair as needed before operation.
 3. Check that tire pressure (air craft tires only) is 40 psi (276 kpa).

4. Check that wheel bolt torque is 93 ft. lb. (126 N•m).
5. Fully clean the equipment. (See “CLEANING THE ROTARY CUTTER” on page 80.)
6. Inspect all safety reflective decals, slow moving vehicle decals and lights where applicable.



Leaking fluids under pressure can enter the skin and cause serious injury or death. Immediate medical attention is required. Wear goggles. Use cardboard to check for leaks.

7. Check condition of all hydraulic components for leaks. Repair as required.

NOTE: Do not operate with hydraulic leaks.

8. Verify that the wing transport locks have been removed and securely stored.
9. Verify that the rotary cutter is properly connected to the tractor with the safety chain.

Break - In Checklist

Check the following mechanical items after 1 hour of operation and again after 10 hours of operation:

1. Check condition of all hydraulic components for leaks. Tighten fittings to correct leaks or replace components. Do not operate with hydraulic leaks.

Figure 10



2. Check the rotary cutter hitch for damaged, loose or missing parts [Figure 10]. Repair as needed before operation.
3. Check for loose fasteners and hardware. Tighten as required.
4. Check that tire pressure (air craft tires only) is 40 psi (276 kpa).
5. Check that wheel bolt torque is 93 ft. lb. (126 Nm).

Tractor Requirements



AVOID SERIOUS INJURY OR DEATH

The tractor must be equipped with an approved Roll Over Protection Structure (ROPS) and safety belts to help prevent personal injury or death caused by tractor roll over.



- Do NOT exceed 540 RPM PTO (if equipped).
- Do NOT exceed 1000 RPM PTO (if equipped).
- Keep PTO shields and all guards in place.
- Keep away from moving parts.
- Keep bystanders away.

The rotary cutter will require a tractor with minimum 65 hp (48 kw) and three pair remote hydraulic outlets.



Towing Vehicle / Tractor must have adequate braking capacity to safely control 5900 lb. (2676 kg) GVW trailing load. Do not exceed 20 mph (32 km/h).

Drawbar Adjustment

Figure 11

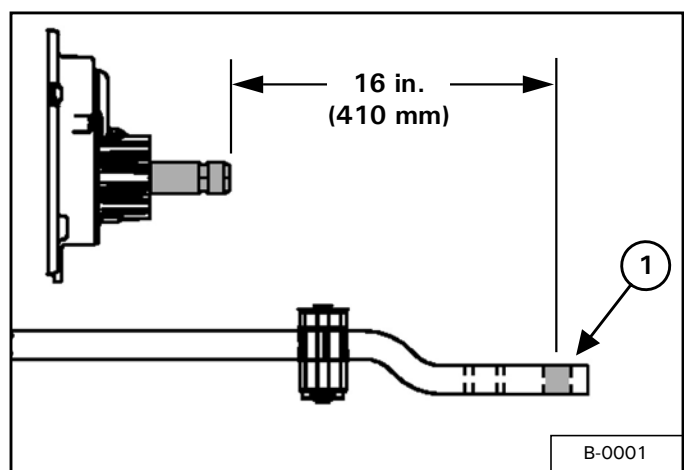

Adjust the tractor's drawbar in / out, until the center of the hitch pin hole (Item 1) [Figure 11] is 16 inches (410 mm) from the end of the tractor's PTO shaft. See your tractor's owner's manual for correct adjustment procedures.

Entering And Leaving The Operator's Position

 **IMPORTANT**

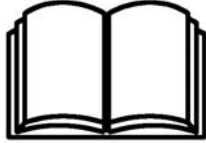

Follow the instructions in your tractor's operation manual for the correct procedure.

Entering The Operator's Position

Move to the operator's position, start the engine and release the parking brake.

Leaving The Operator's Position

 **WARNING**

AVOID INJURY OR DEATH

Before you leave the operator's position:

- **Always park on a flat level surface.**
 - **Place all controls in NEUTRAL.**
 - **Engage the park brake.**
 - **Stop the engine and remove the key.**
 - **Wait for all moving parts to stop.**
-

Park the tractor / equipment on a flat level surface.

Place all controls in neutral, engage the park brake, stop the engine and wait for all moving parts to stop. Leave the operator's position.

INITIAL SET-UP

Frame Lock

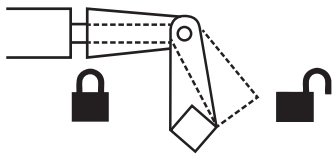

Engage frame lock bracket and retainer before transporting, storing or working under frame to prevent machine from falling down and crushing someone.

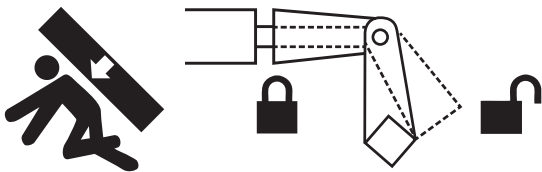

CRUSHING HAZARD CAN CAUSE SERIOUS INJURY OR DEATH

- Engage transport locks.
- Block up before servicing.
- Purge air from hydraulic system before attempting to raise or lower implement.

Frame Lock Engaged

Figure 12

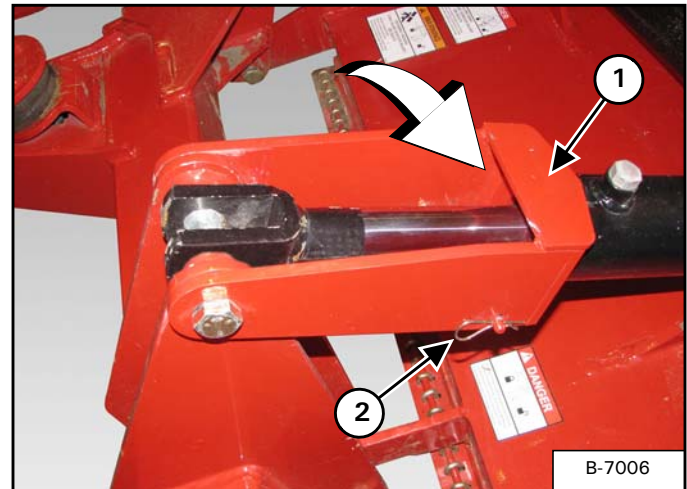

When transporting, storing or working under rotary cutter the frame lock bracket (Item 1) must be rotated over the lift cylinder shaft and secured in position with the rod and retaining clip (Item 2) [Figure 12].

Frame Lock Disengaged

Figure 13

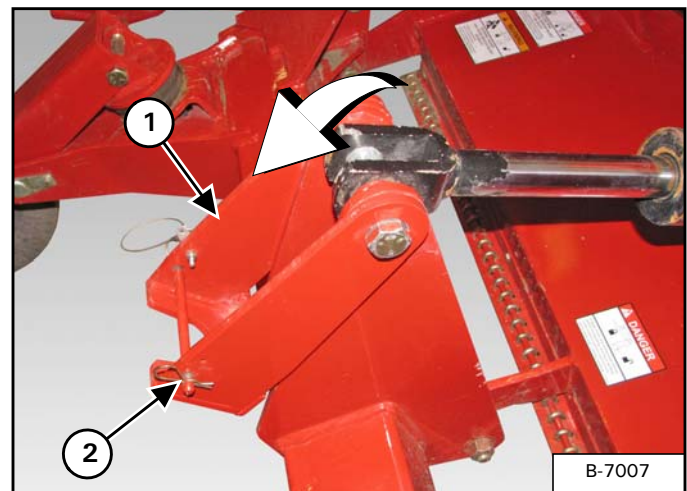

When operating the rotary cutter, remove the rod and retaining clip (Item 2) [Figure 12].

Rotate the frame lock bracket (Item 1) back against the lift cylinder mount on the center axle. Re-install the rod and retaining clip (Item 2) [Figure 13].

Wing Transport Locks



FALLING WING CAN CAUSE SERIOUS INJURY OR DEATH

- Always secure wing transport locks before transporting, servicing, or parking the cutter.
- Stand clear when lowering or raising wings.

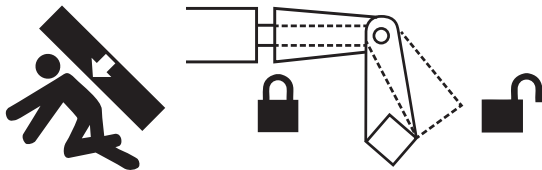

CRUSHING HAZARD CAN CAUSE SERIOUS INJURY OR DEATH

- Engage transport locks.
- Block up before servicing.
- Purge air from hydraulic system before attempting to raise or lower implement.

Wing Transport Lock Engaged

Figure 14

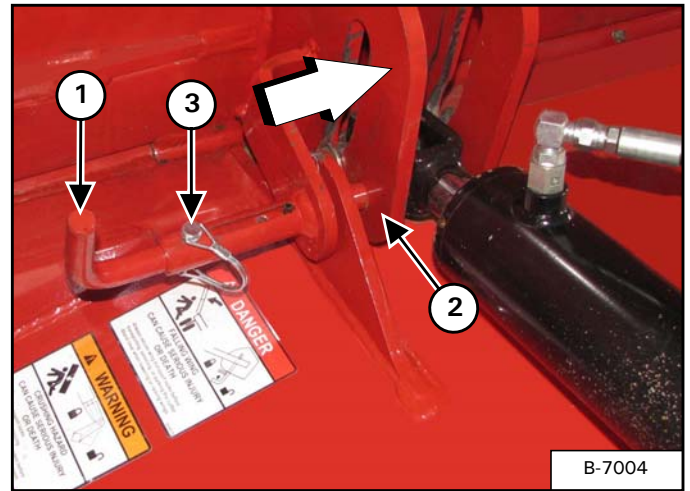

When transporting, storing or working under rotary cutter the wing transport lock (Item 1) (both sides) must be pushed forward until the wing transport lock fully engages the hole (Item 2) [Figure 14] in the wing cylinder mounting bracket.

Install retaining pin (Item 3) [Figure 14] to secure the wing transport lock in the engaged position.

Wing Transport Lock Disengaged

Figure 15

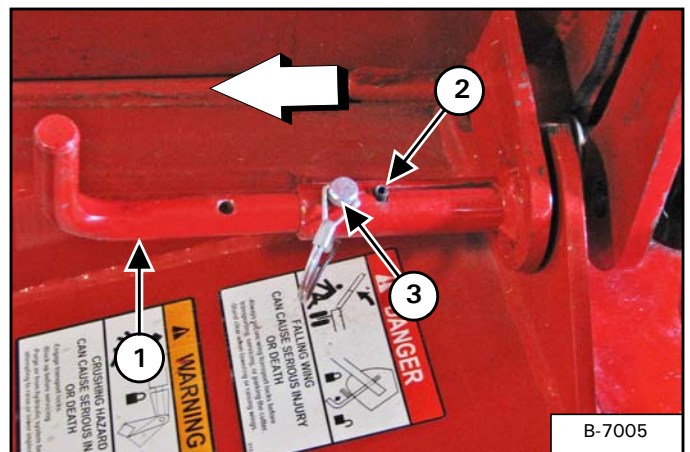

Before lowering the wings, remove the retaining pin (Item 3) [Figure 14].

Pull the wing transport lock (Item 1) back until the roll pin (Item 2) stops the wing transport lock. Re-install the retaining pin (Item 3) [Figure 15] to secure the wing transport lock in the disengaged position.

Connecting The Rotary Cutter To The Tractor

Always inspect the tractor’s drawbar and Rotary Cutter hitch before connecting. See the tractor’s owner’s manual.

Verify that the tractor’s drawbar is adjusted correctly for use with the Rotary Cutter. (See “Drawbar Adjustment” on page 38.)

Figure 16

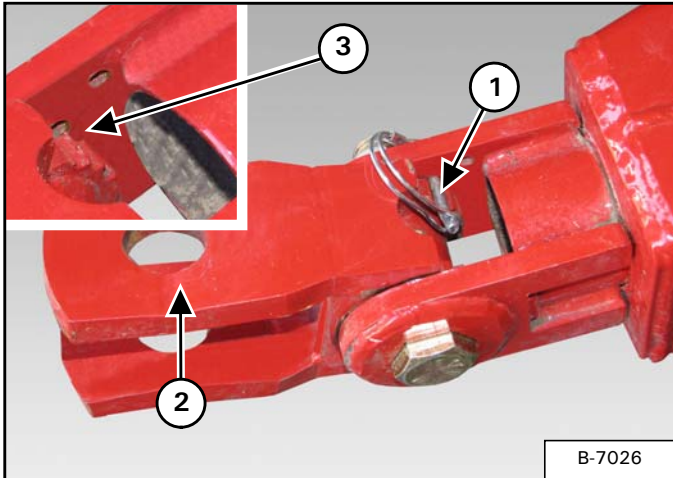

Remove snapper clip (Item 1) and rotate the clevis (Item 2) up or down until the clevis is parallel to the ground. Align the closest notch (Item 3) [Figure 16] on the clevis with hole and re-install the snapper clip.

Enter the operator’s position. (See “Entering The Operator’s Position” on page 39.)

Move the tractor into position in front of the Rotary Cutter.



AVOID INJURY OR DEATH

Before moving the tractor, look in all directions and make sure no bystanders, especially small children are in the work area. Do not allow anyone between the tractor and the equipment when backing up to the equipment for connecting.

Move the tractor backwards, aligning the drawbar with the Rotary Cutter hitch.

NOTE: The jack may need to be lowered or raised for proper alignment of the drawbar and hitch.

If the Rotary Cutter hitch needs to be adjusted, stop the tractor when drawbar is just in front of the Rotary Cutter hitch.

Leave the operator’s position. (See “Leaving The Operator’s Position” on page 39.)

Figure 17

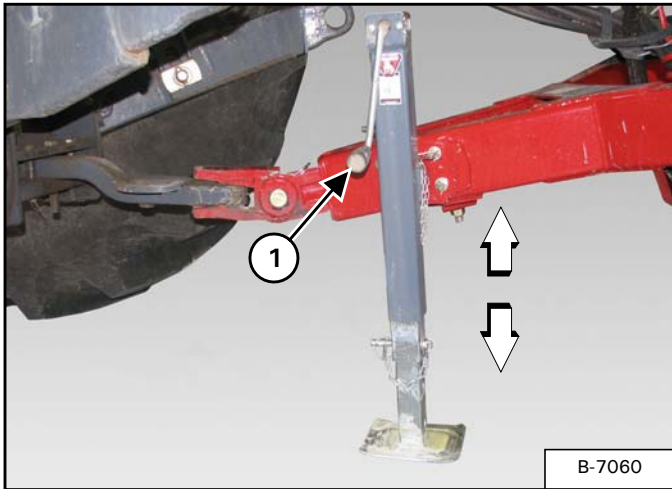

Turn the handle (Item 1) [Figure 17] clockwise to raise the hitch or counterclockwise to lower the hitch.

Lower or raise the Rotary Cutter hitch until aligned with the tractor's drawbar.

Move to the operator's seat, start the engine and release the parking brake.

Move the tractor backwards, aligning the drawbar hitch pin hole with the Rotary Cutter hitch pin hole(s).

Stop the tractor and leave operator's position.



AVOID INJURY OR DEATH

Keep fingers and hands out of pinch points when connecting and disconnecting equipment.

NOTE: Always use a hitch pin of adequate size and strength and a retaining pin with a locking device.

Figure 18

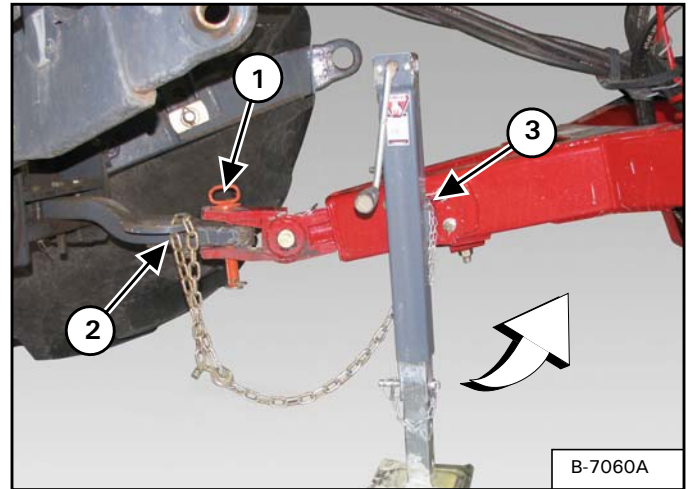

Install the hitch pin (Item 1) [Figure 18] and retaining pin to securely fasten the Rotary Cutter hitch to the tractor drawbar.

Attach the safety chain (Item 2) [Figure 18] around the drawbar.

Remove retaining pin (Item 3) [Figure 18], rotate the jack into the operation / storage position. Re-install retaining pin.

Figure 19

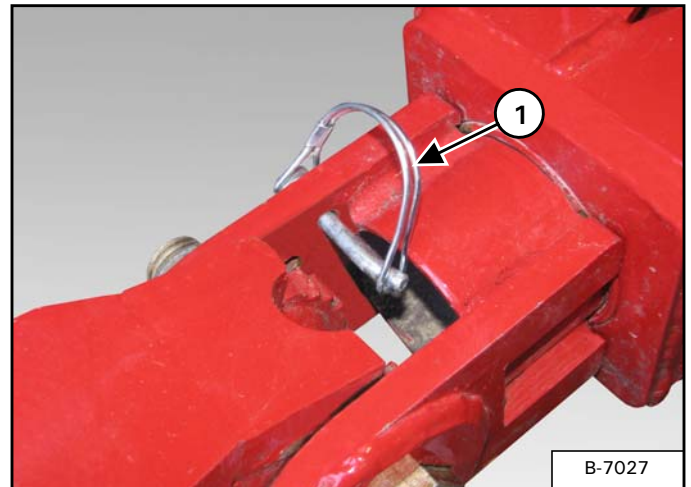

Remove snapper clip (Item 1) [Figure 19] and re-install in the storage hole on the hitch.

Connecting The PTO Driveline



AVOID INJURY OR DEATH

Warnings on the machine and in the manuals are for your safety. Failure to obey warnings can cause serious injury or death.

NOTE: Clean and grease tractor's PTO shaft and PTO driveline coupling each time driveline is connected.

Stop the engine and leave the operator's position. (See "Leaving The Operator's Position" on page 39.)



Improper hitch installation can cause PTO driveline damage.

- Do not modify the hitch or use an unapproved hitch.
- Make sure the PTO driveline is of adequate length and that u-joints are in the correct phase.

Remove the PTO driveline from the storage position (if applicable).

Figure 20

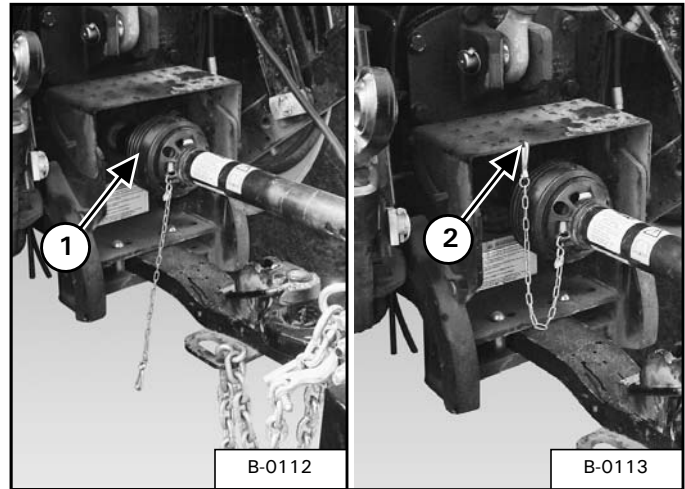

Retract the collar and slide the PTO driveline (Item 1) [Figure 20] onto the tractor PTO shaft until it locks onto the shaft. Push and pull on the PTO driveline to verify it is securely attached to the PTO shaft. Install PTO driveline safety chain (Item 2) [Figure 20].

NOTE: The PTO driveline must have a means to retain it to the PTO shaft on the tractor.



- Do NOT exceed 540 RPM PTO (if equipped).
- Do NOT exceed 1000 RPM PTO (if equipped).
- Keep PTO shields and all guards in place.
- Keep away from moving parts.
- Keep bystanders away.

PTO Driveline

PTO Driveline Length Check

NOTE: Due to variations in distances between tractor PTO shafts and implement input shafts, drivelines may need to be shortened or a longer shaft may be required. When fitting the implement to the tractor, the PTO driveline, with telescoping sections, must be inspected. When the sections are at the most compressed operating position, the sections must not “bottom out”. At its shortest length, there must be at least 2 in. (50.8 mm) of clearance between each section end and opposite section end at the most compressed operating position. When the sections are at the most extended position, there must be sufficient engagement between the sections. At its farthest operating extension, a minimum section engagement of 33% of shaft length must be maintained.



WARNING

AVOID INJURY OR DEATH

- Do NOT exceed the rated implement PTO speed.
- Stay clear of rotating driveline.
- Keep bystanders away.
- Keep hands, feet, clothing and long hair away.
- Keep PTO shields and all guards in place.
- Disengage PTO, move the tractor controls to the Neutral position, stop the engine and make sure all rotating components are stopped before leaving the operator’s position.
- Do NOT service the tractor or implement with the PTO engaged.
- Do NOT service the implement in a raised position unless properly blocked and with all rotating components stopped.
- Disengage PTO for road travel.

PTO Driveline Bottoming Out Check

Stop the engine and leave the operator’s position. (See “Leaving The Operator’s Position” on page 39.)

Make sure the PTO driveline and all rotating components have come to a complete stop before leaving the operator’s position (if applicable).

Figure 21

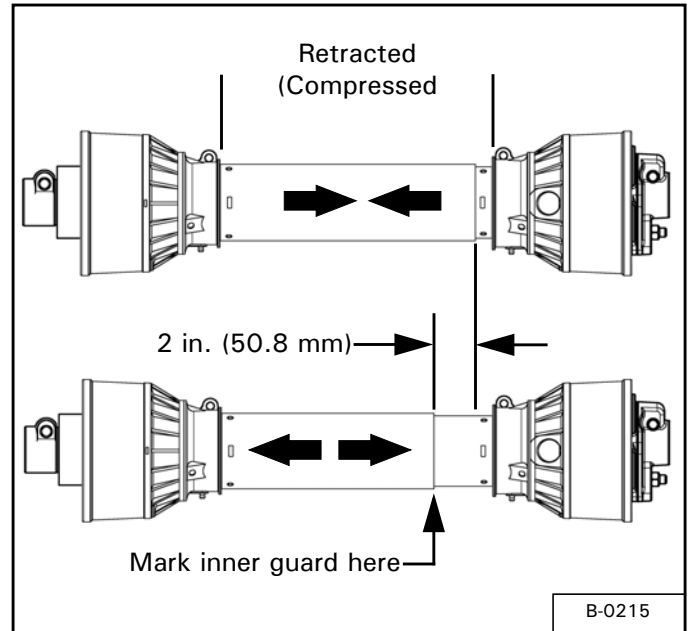

1. Disconnect the PTO driveline from the tractor and slide the PTO driveline together until fully retracted (compressed).
2. Measure the retracted (compressed) length of PTO driveline [Figure 21].
3. Extend the PTO driveline 2 in. (50.8 mm) from the retracted length and place a mark on the inner guard at the end of the outer guard [Figure 21].
4. Reattach the PTO driveline to the tractor PTO shaft.
5. Enter the operator’s position. (See “Entering The Operator’s Position” on page 39.) Start the engine.
6. With the rear PTO DISENGAGED, raise and lower the implement and watch the PTO driveline extend and retract.
7. If the outer PTO driveline guard slides in (retracts) over the mark at any point of travel, the PTO driveline needs to be shortened.

Reducing The PTO Driveline Length

Stop the engine and leave the operator's position. (See "Leaving The Operator's Position" on page 39.)

Make sure the PTO driveline and all rotating components have come to a complete stop before leaving the operator's position.



AVOID INJURY OR DEATH

- Do NOT exceed the rated implement PTO speed.
- Stay clear of rotating driveline.
- Keep bystanders away.
- Keep hands, feet, clothing and long hair away.
- Keep PTO shields and all guards in place.
- Disengage PTO, move the tractor controls to the Neutral position, stop the engine and make sure all rotating components are stopped before leaving the operator's position.
- Do NOT service the tractor or implement with the PTO engaged.
- Do NOT service the implement in a raised position unless properly blocked and with all rotating components stopped.
- Disengage PTO for road travel.

Remove the PTO driveline from the tractor and place in storage position (if equipped).

Enter the operator's position. (See "Entering The Operator's Position" on page 39.) Start the engine.

Raise or lower the Rotary Cutter to get the shortest distance between the tractor PTO shaft and Rotary Cutter gearbox PTO shaft.

Stop the engine and leave the operator's position. (See "Leaving The Operator's Position" on page 39.)

Pull the PTO driveline apart and reinstall each individual section; one half to the tractor PTO shaft and one half to the implement gearbox PTO shaft.

Figure 22

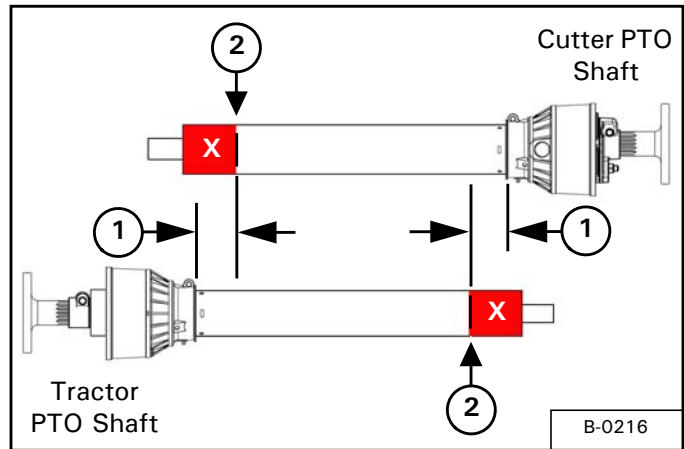

1. Hold PTO driveline sections parallel to one another and measure back 2 in. (50.8 mm) (Item 1) from the yoke of each section and place mark on opposite section. Cut the plastic shield at this length (Item 2) [Figure 22].

Figure 23

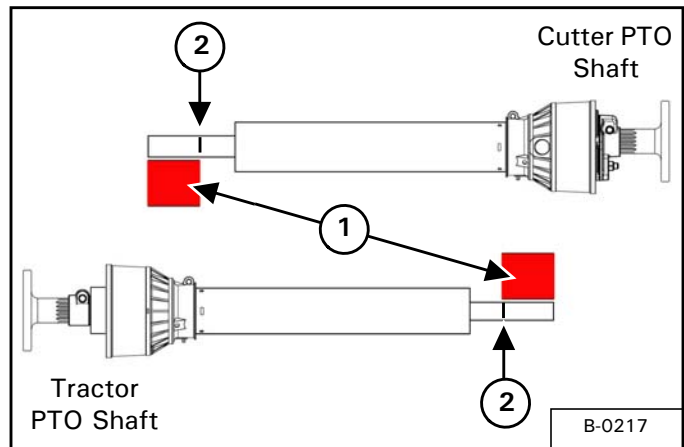

2. Using the plastic guard lengths that were cut off in [Figure 22], align the cut off lengths (Item 1) with the end of the inner & outer shafts. Place a mark (Item 2) [Figure 23] on the inner & outer shafts and cut the inner & outer shafts off at this length.
3. Round off all sharp edges and debur.
4. Thoroughly grease and install the PTO driveline halves together.
5. Recheck for proper operation.

PTO Driveline Engagement Check

Stop the engine and leave the operator’s position. (See “Leaving The Operator’s Position” on page 39.)

Make sure the PTO driveline and all rotating components have come to a complete stop before exiting the compact tractor.



AVOID INJURY OR DEATH

- Do NOT exceed the rated implement PTO speed.
- Stay clear of rotating driveline.
- Keep bystanders away.
- Keep hands, feet, clothing and long hair away.
- Keep PTO shields and all guards in place.
- Disengage PTO, move the tractor controls to the Neutral position, stop the engine and make sure all rotating components are stopped before leaving the operator’s position.
- Do NOT service the tractor or implement with the PTO engaged.
- Do NOT service the implement in a raised position unless properly blocked and with all rotating components stopped.
- Disengage PTO for road travel.

1. Disconnect the PTO driveline from the tractor and fully slide the driveline sections together (retracted).

Figure 24

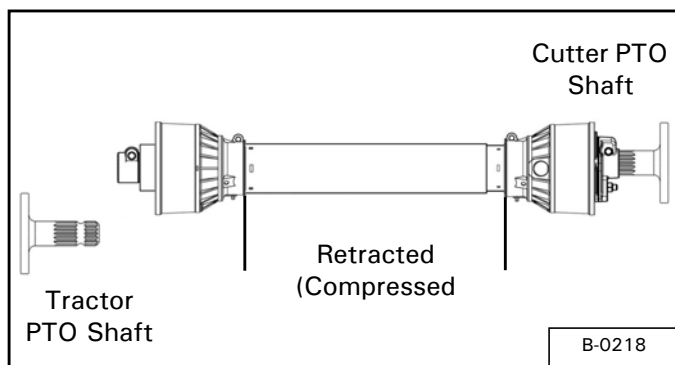

2. Measure the retracted (compressed) length of the PTO driveline between the bases of the plastic guards [Figure 24].

3. Multiply the retracted driveline length by 1.667 to determine the PTO driveline Maximum Operating Length. (i.e.: 25.5 in. (647,7 mm) x 1.667 = 42.5 in. (1079,7 mm) Maximum Operating Length).
4. Attach the PTO driveline to the tractor PTO output shaft.
5. Enter the operator’s position. (See “Entering The Operator’s Position” on page 39.)
6. With the PTO driveline attached, position the Rotary Cutter to where the telescoping PTO driveline is at its maximum operating extension.
7. Stop the engine and leave the operator’s position. (See “Leaving The Operator’s Position” on page 39.) Make sure the PTO driveline and all rotating components have come to a complete stop before leaving the operator’s position.

Figure 25

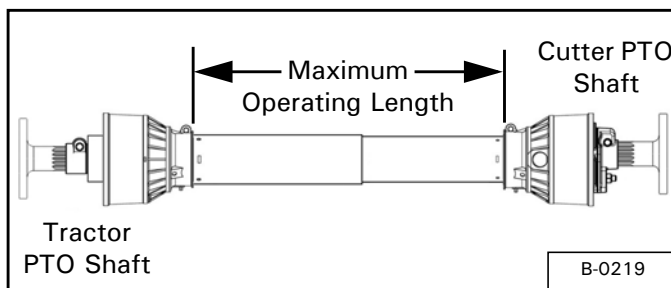

8. Measure the length of the PTO driveline between the bases of the plastic shields [Figure 25] to determine the maximum operating length.

A. If the measured maximum operating length is less than the Maximum Operating Length calculation (from Step 3), the PTO driveline has adequate engagement

B. If the measured maximum operating length is equal to or more than the Maximum Operating Length calculation (from Step 3), the PTO driveline does not have adequate engagement and should be replaced with a longer driveline. See your Farm King dealer for available PTO drivelines.

Connecting Hydraulic Hoses



HIGH PRESSURE FLUID HAZARD

To prevent serious injury or death from high pressure fluid:

- Relieve pressure on system before repairing or adjusting.
- Wear proper hand and eye protection when searching for leaks. Use wood or cardboard instead of hands.
- Keep all components in good repair.



- Contain and dispose of any oil leakage in an environmentally safe manner.
- Thoroughly clean the quick couplers before making connections. Dirt can quickly damage the system.

NOTE: Make sure the quick couplers are fully engaged. If the quick couplers do not fully engage, check to see that the couplers are the same size and type.

To Connect:

Figure 26

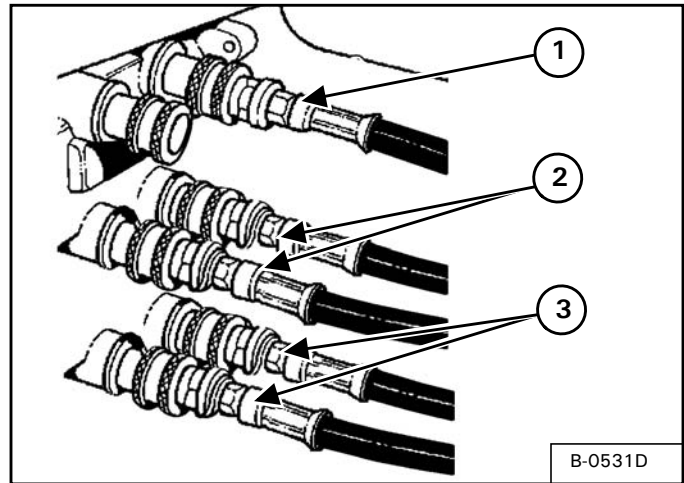

Pull back on the collar of the female coupler, push couplers together, release the collar when the couplers are fully engaged and locked [Figure 26].

Install the lift cylinder quick coupler hose (Item 1) [Figure 26] (Yellow dust cap).

Install the RH wing cylinder quick coupler hoses (Item 2) [Figure 26] (Blue dust cap).

Model 1530

Install the LH wing cylinder quick coupler hoses (Item 3) [Figure 26] (Green dust cap).

To Disconnect:



AVOID BURNS

Hydraulic fluid, tubes, fittings and quick couplers can get hot when running equipment. Be careful when connecting and disconnecting quick couplers.

Pull back on the collar and pull the male coupler out to disconnect.

Lower jack until weight of equipment is resting on tractor drawbar. Pull retaining pin on jack and remove. Mount jack to storage bracket and secure with retaining pin.

Purging The Hydraulic System

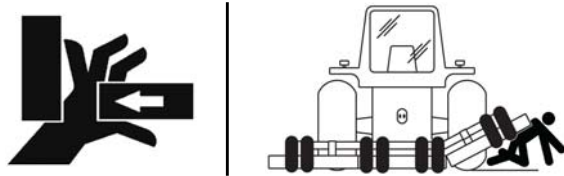

PINCHING / CRUSHING HAZARD

To prevent serious injury or death from pinching or crushing:

- Air in the hydraulic system will cause the wings to drop suddenly when lowering.
- Keep away from wings when engine is running.
- Keep bystanders away.

Enter the tractor. (See “Entering The Operator’s Position” on page 39.)

Start the engine and engage the tractor auxiliary hydraulics.

Using the individual tractor auxiliary controls:

Fully extend and retract RH & LH wing hydraulic cylinders to remove any air in the hydraulic system.

Fully extend and retract lift hydraulic cylinder to remove any air in the hydraulic system.

Fully unfold RH & LH wings and lower the rotary cutter frame until the skid shoes contact the ground.

Turn tractor engine off and exit the tractor. (See “Leaving The Operator’s Position” on page 39.)

PRE OPERATION

Recommended Deck Height



- Adjust the deck height to the tractor’s drawbar. Drawbar heights vary depending on the tractor being used.
- The Rotary Cutter usually performs best with the front raised higher than the rear.

Cutting Conditions

Light Material / Normal Cutting - Set front of deck level to one inch (25.4 mm) higher than the rear.

Brush Or Dense Tall Weeds - Set front of deck two - three inches (51 - 76 mm) higher than the rear.

Rough Ground Cutting - Adjust the front of the cutter two - three inches (51 - 76 mm) higher than the rear to hold the front blade up, keeping the front blade from contacting the rough ground.

NOTE: Operator can adjust deck to a height to best obtain the finished cutting desired.

Leveling The Center Deck

Connect the rotary cutter to the tractor. (See "Connecting The Rotary Cutter To The Tractor" on page 42.)

Enter the tractor, start the engine and engage tractor auxiliary hydraulics.

Fully raise RH & LH wings and center deck (if required).

Move the tractor and rotary cutter to a flat level surface.

Engage the tractor's parking brake, turn tractor engine off and exit the tractor. (See "Leaving The Operator's Position" on page 39.)

Figure 27

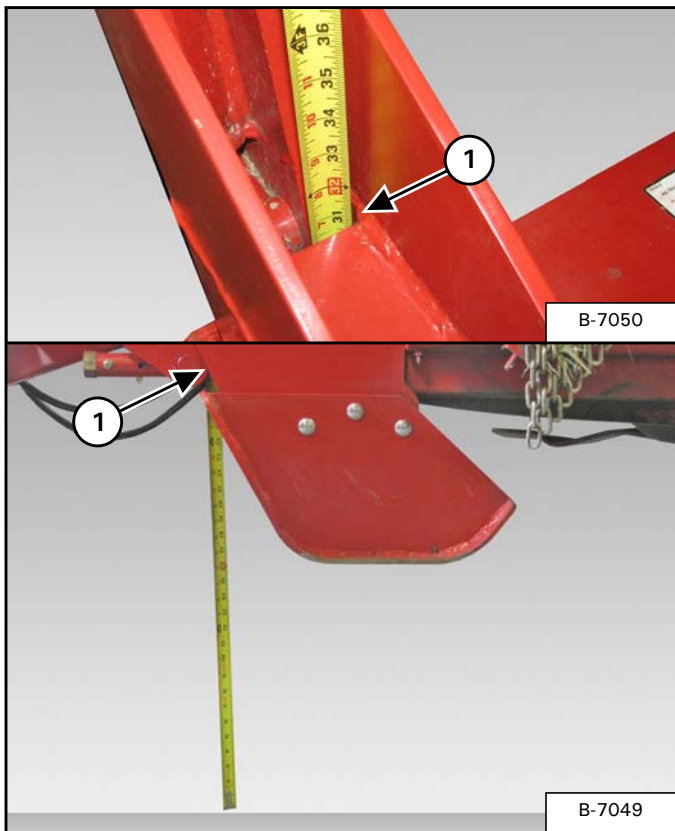

Measure the distance from the ground to the top of the front deck tube (Item 1) [Figure 27] (both sides). Record measurement.

Figure 28

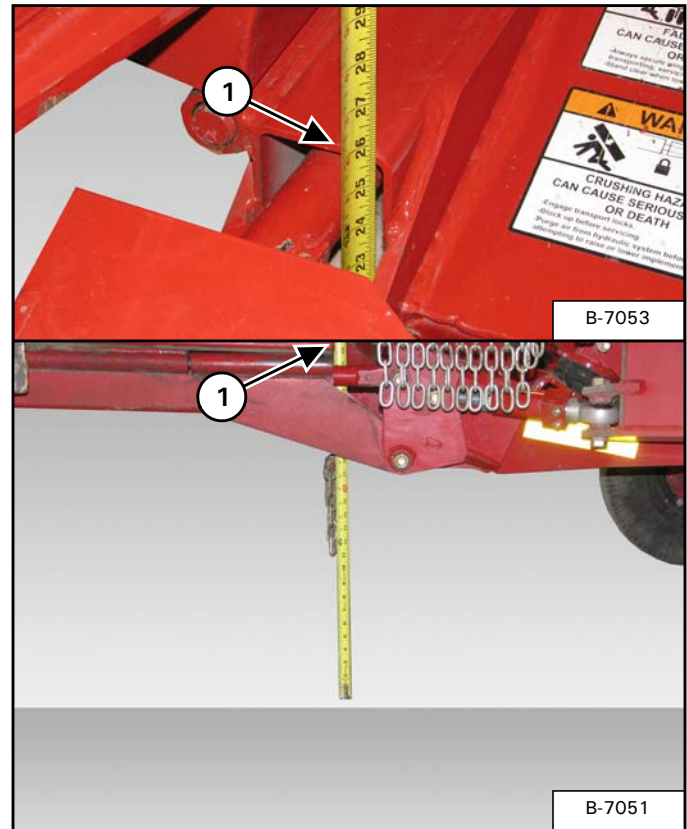

Measure the distance from the ground to the top of the rear deck tube (Item 1) [Figure 28] (both sides). Record measurement.

Figure 29

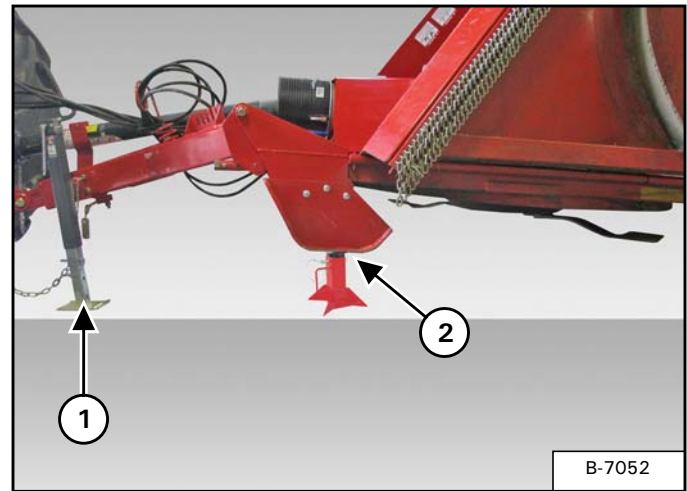

Lower the jack (Item 1), place a jack stand (Item 2) [Figure 29] under the skid shoe (both sides).

Disconnect the Rotary Cutter from the tractor.

Figure 30

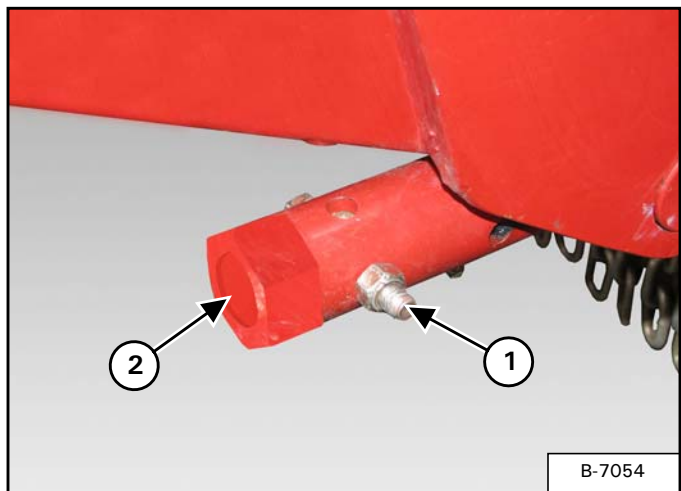

Remove 3/8" bolt (Item 1) [Figure 30] and lock nut.

To Raise The Front Of The Deck

Turn the adjustment rod (Item 2) [Figure 30] clockwise to raise the front of the deck (both sides).

To Lower The Front Of The Deck

Turn the adjustment rod (Item 2) [Figure 30] counter-clockwise to lower the front of the deck (both sides).

! IMPORTANT

Turn LH & RH adjustment rods evenly.

Leveling The RH & LH Wings

Level center deck prior to leveling wings. (See "Leveling The Center Deck" on page 50.)

! IMPORTANT

The top of the RH & LH wings must be level with the top of the middle deck.

Connect the rotary cutter to the tractor. (See "Connecting The Rotary Cutter To The Tractor" on page 42.)

Enter the tractor, start the engine and engage tractor auxiliary hydraulics.

Using the tractor controls, fully raise the center deck.

Move the tractor and Rotary Cutter to a flat level surface.

Engage the tractor's parking brake, turn tractor engine off and exit the tractor. (See "Leaving The Operator's Position" on page 39.)

Place jack stands under center deck.

Remove frame lock from transport position. (See "Frame Lock" on page 40.)

Remove wing transport locks from transport position. (See "Wing Transport Locks" on page 41.)

Enter the tractor, start the engine and engage tractor auxiliary hydraulics.

Using the tractor controls, fully lower RH & LH wings.

Engage the tractor's parking brake, turn tractor engine off and exit the tractor. (See "Leaving The Operator's Position" on page 39.)

Apply down pressure / bounce the wings to settle the wings.

Figure 31

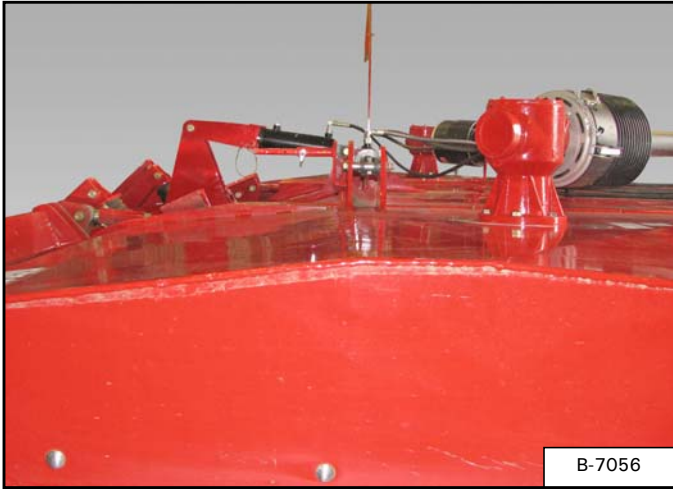

Visually sight across the top of the wings and center deck to verify that the wings are level with the center deck [Figure 31].

Lowering Outer Edge / Side Of Wing

Figure 32

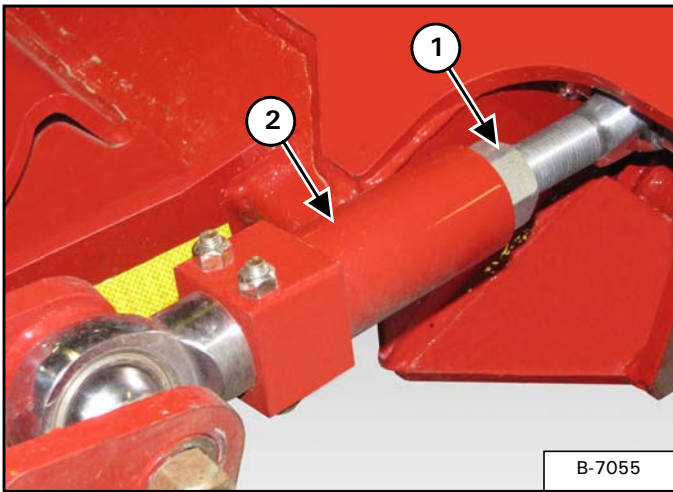

Loosen the jam nut (Item 1). Rotate the turnbuckle assembly (Item 2) [Figure 32] clockwise to lower the outer edge / side of the wing.

Rotate turnbuckle assembly until the wing is level with the center deck or at the desired height. Tighten jam nut.

Repeat for opposite wing.

Raising Outer Edge / Side Of Wing

Loosen the jam nut (Item 1). Rotate the turnbuckle assembly (Item 2) [Figure 32] counter-clockwise to raise the outer edge / side of the wing.

Rotate turnbuckle assembly until the wing is level with the center deck or at the desired height. Tighten jam nut.

Repeat for opposite wing.

OPERATING THE ROTARY CUTTER

Cutting Procedure

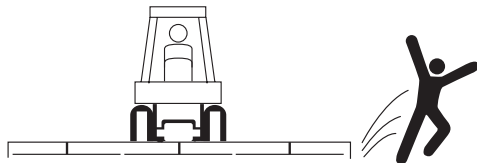

THROWN OBJECT HAZARD

To prevent serious injury or death from thrown objects:

- Stay clear and watch out for bystanders. Stop if bystanders come close to work area. Keep all shields in place. Use protective shields on all discharge openings at front and rear of deck whenever possible.
- Before working on mower: Disengage power, shut off engine, remove key and make sure all blades have stopped turning.



ROTATING BLADES CAN CAUSE SERIOUS INJURY OR DEATH

- Stay clear of rotating parts.
- Blades may rotate for several minutes after power shut off.
- Do not place hands or feet under or into cutter.
- Disengage power, stop engine, set park brake, remove ignition key and make sure blades have stopped turning before leaving cab.

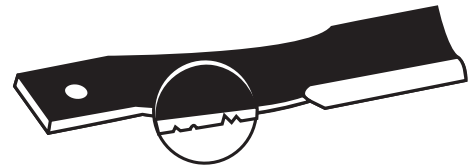

DAMAGED BLADES CAN CAUSE SERIOUS INJURY OR DEATH

- Inspect blades daily for chips, cracks, wear and abnormal bends.
- Replace blades with genuine Farm King blades only.
- Unbalanced blades are dangerous.
- Replace blades in pairs.



FALLING WING CAN CAUSE SERIOUS INJURY OR DEATH

- Always secure wing transport locks before transporting, servicing, or parking the cutter.
- Stand clear when lowering or raising wings.



AVOID SERIOUS INJURY OR DEATH

Do not operate Rotary Cutter when deck or wings are raised. Exposed rotating blades create a potential hazard of thrown objects which may lead to serious injury or death.

⚠ WARNING

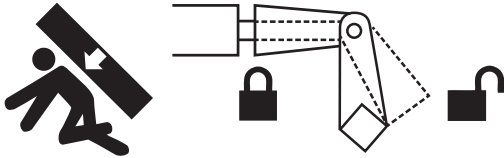

- Purge air from hydraulic system before attempting to raise or lower implement.

⚠ WARNING



ROLL OVER HAZARD CAN CAUSE SERIOUS INJURY OR DEATH

- Decrease speed when turning.
- Be careful on slopes with wings raised.
- Do not operate with raised wings.

⚠ WARNING



- Do NOT exceed 540 RPM PTO speed.
- Do NOT exceed 1000 RPM PTO speed.
- Keep PTO shields and all guards in place.
- Keep away from moving parts.
- Keep bystanders away.
- Verify that the PTO driveline does not contact the cutter when raising and lowering or when cornering.

⚠ IMPORTANT

Do not allow hydraulic hoses to contact brush, branches, and other objects that could cause damage to the hydraulic hoses.

⚠ IMPORTANT

Do not exceed the rated PTO speed. Excessive speed will cause damage to the drive components.

⚠ IMPORTANT

Avoid making tight turns where the rear tractor tires and three-point arms may contact the rotary cutter hitch, PTO drivelines or wing decks. Fully raise the three-point arms when operating / transporting the rotary cutter.

Connect the rotary cutter to the tractor. (See “Connecting The Rotary Cutter To The Tractor” on page 42.)

Enter the tractor, start the engine and release the parking brake.

Raise the rotary cutter to the travel position.

Move the tractor and rotary cutter to the work area.

Position the tractor and rotary cutter at the starting point of cutting area.

Stop the tractor, engage the parking brake and turn the engine off.

Leave the operator’s position. (See “Entering And Leaving The Operator’s Position” on page 39.)

Remove frame lock. (See “Frame Lock” on page 40.)

Remove transport locks. (See “Wing Transport Locks” on page 41.)

Enter the tractor and start the engine.

Using the tractor controls, lower the wings.

Stop the tractor, engage the parking brake and turn the engine off.

Leave the operator’s position. (See “Entering And Leaving The Operator’s Position” on page 39.)

Adjust the rotary cutter to the desired cutting height. (See “Recommended Deck Height” on page 49.)

Enter the tractor, start the engine and release the parking brake.

 **WARNING**



- **Do NOT exceed 540 RPM PTO (if equipped).**
- **Do NOT exceed 1000 RPM PTO (if equipped).**
- **Keep PTO shields and all guards in place.**
- **Keep away from moving parts.**
- **Keep bystanders away.**

540 RPM Operating PTO Speed

Engage the tractor’s PTO, increase tractor PTO speed to 540 rpm when doing normal cutting.

NOTE: If the forward speed is too high, a lower gear can be used.

1000 RPM Operating PTO Speed

Engage the tractor’s PTO, increase tractor PTO speed to 1000 rpm when doing normal cutting.

NOTE: If the forward speed is too high, a lower gear can be used.

 **IMPORTANT**

Recommended operating ground speed is 0 - 5 mph (0 - 8 km/h). Use slower speeds when operating on or near steep slopes, ditches, drop-offs, rough terrain, overhead obstructions, power lines, or when avoiding obstacles and other foreign debris.

Wing Float Position

It is recommended whenever possible to operate both LH & RH wings (if applicable) in the float position allowing the cylinder to be free to extend or retract allowing the Rotary Cutter to follow the contour of the work area.

Cutting Angles



It is not recommended to operate Rotary Cutter wings raised at an angle greater than 25 degrees to prevent damage to the PTO drivelines and help prevent personal injury from thrown objects or debris.

Figure 33

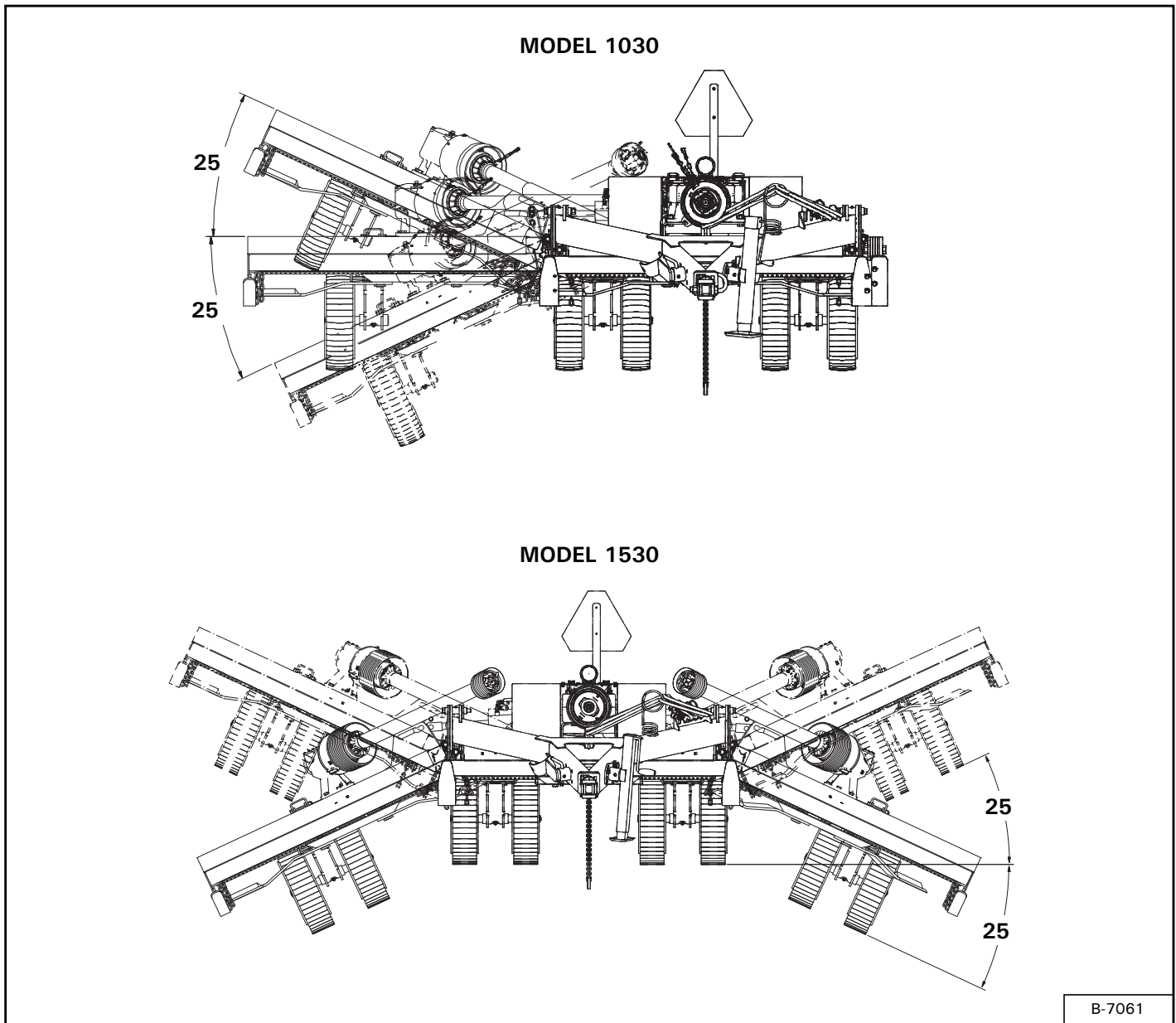

The LH & RH Rotary Cutter wings can be operated at angles of up to 25 degrees down and 25 degrees up [Figure 33].

Cutting Recommendations

NOTE: Loss of power / PTO speed will result in uneven cutting. Adjust travel speed as required for material being cut, while maintaining the rated operating PTO speed (540 rpm / 1000 rpm PTO speed).

Light Material / Normal Cutting

Adjust the front of the cutter one inch (25.4 mm) higher than the rear or level for light / normal cutting.

Brush Or Dense Tall Weeds

Adjust the front of the cutter two - three inches (51 - 76 mm) higher than the rear to better shred brush or dense tall weeds.

Rough Ground Cutting

Adjust the front of the cutter two - three inches (51 - 76 mm) higher than the rear to hold the front blade up, keeping the front blade from contacting the rough ground.

Figure 34

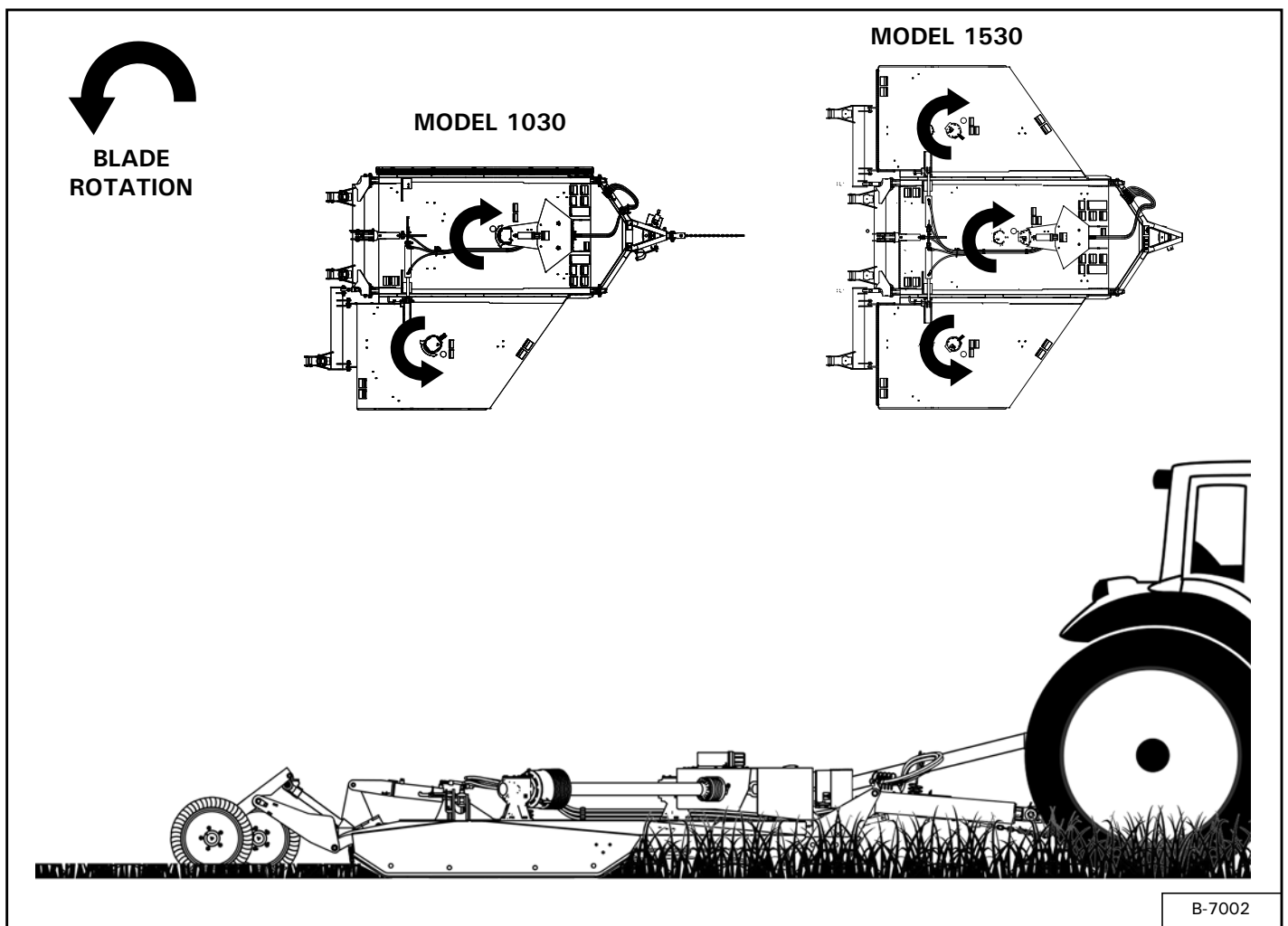

Adjust Rotary Cutter to the desired height, engage the tractor PTO, lower the Rotary Cutter and begin cutting [Figure 34].

TRANSPORTING

Requirements



ELECTROCUTION HAZARD

To prevent serious injury or death from electrocution:

- Be aware of overhead power lines.
- Keep away from power lines when transporting or raising Rotary Cutter wings.
- Electrocution can occur without direct contact.



Use of an unapproved hitch or tractor / tow vehicle can result in loss of control, leading to serious injury or death.

Tractor / tow vehicle and hitch must have the rated capacity to tow equipment.



- Do not operate the unit before reading and understanding the Operator Manual.
- Make certain everyone is clear of the equipment before applying power or moving the machine.
- Raise unit to the recommended transport position before transporting.
- Disconnect PTO driveline from the tractor before moving or transporting.



Never exceed 20 mph (32 kph).



Do not move or transport the Rotary Cutter unless the wings are in the raised / transport position and securely locked before transporting.

Comply with federal, state, local and provincial laws regarding the transport of farm equipment on public roadways.

Verify that the tractor / tow vehicle is approved for transporting the equipment and that the equipment is securely attached to the tractor / tow vehicle.

Verify safety chain is installed and properly connected before transporting equipment.

Verify that the SMV (Slow Moving Vehicle) emblem, all lights and reflectors are clean and visible.

Disconnect the PTO driveline from the tractor before transporting.

Transporting Guidelines

The ratio of the tractor / tow vehicle weight to the loaded equipment weight plays an important role in defining acceptable travel speed.

TRAVEL SPEED - Acceptable travel speed.

WEIGHT RATIO - Weight of fully equipped or loaded implement(s) relative to weight of tractor / tow vehicle.

TRAVEL SPEED	WEIGHT RATIO
Up to 20 mph (32 kph)	1 to 1 (or less)
Up to 10 mph (16 kph)	2 to 1 (or less)
DO NOT TOW	More than 2 to 1

Transporting Procedure

Enter the tractor, start the engine and engage the tractor’s hydraulics.

Using the tractor’s hydraulic controls, fully raise the center deck, then fully raise the wings. Run the tractor engine at low idle.

Stop the tractor, engage the parking brake and turn the engine off.

Leave the operator’s position. (See “Entering And Leaving The Operator’s Position” on page 39.)

Lock wings in the transport position. (See “Wing Transport Locks” on page 41.)

Engage the frame lock. (See “Frame Lock” on page 40.)

Figure 35

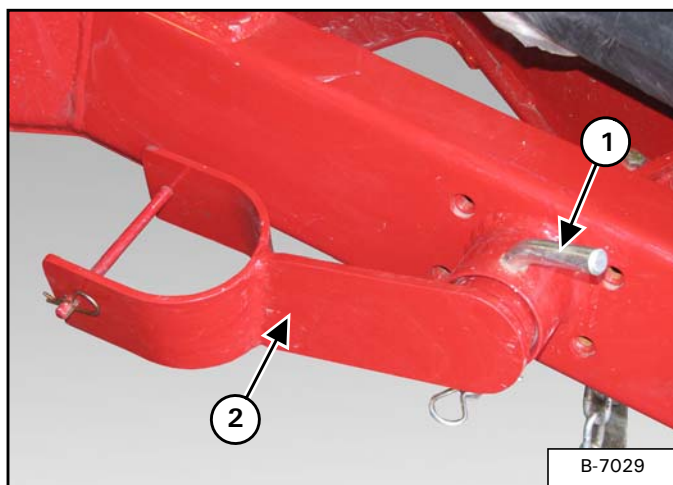

Remove the retaining clip and pin (Item 1) [Figure 35].

Rotate the PTO driveline holder (Item 2) [Figure 35] up 90° to the transport position. Re-install pin and retaining clip.

Figure 36

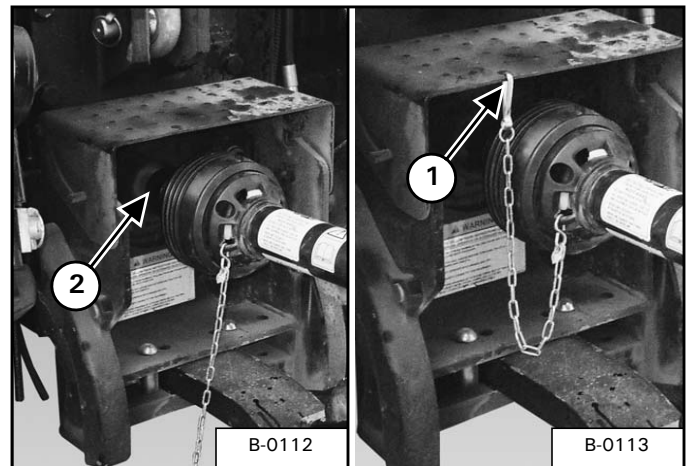

Remove the PTO driveline safety chain (Item 1). Retract the collar (Item 2) [Figure 36] and slide the PTO driveline off the tractor PTO shaft.

Figure 37

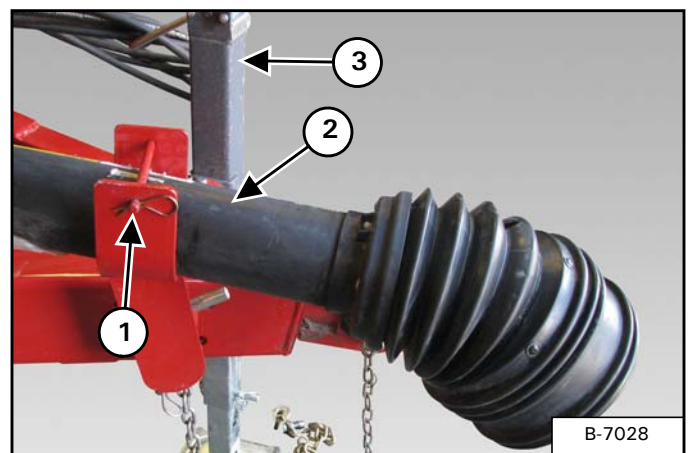

Remove the retaining clip and pin (Item 1) [Figure 37].

Place the PTO driveline (Item 2) [Figure 37] in the holder. Re-install pin and retaining clip.

Fully raise the jack (Item 3) [Figure 37] and rotate into the transport position (horizontal).

Verify that the Rotary Cutter is securely fastened to the tractor / tow vehicle and that the hitch safety chain is properly attached to the Rotary Cutter and tractor / tow vehicle.

Verify that the SMV (Slow Moving Vehicle) sign is attached and visible.

Verify that the amber lights are clean and operating correctly.

Farm King



MAINTENANCE

TROUBLESHOOTING63
 General Chart63
 Blades64
SERVICE SCHEDULE65
 Maintenance Intervals65
LUBRICATION66
 Recommendations66
 Locations66
SPLITTER GEARBOX70
 Checking Gear Oil Level70
 Changing Gear Oil71
RIGHT ANGLE GEARBOX74
 Checking Gear Oil Level74
 Changing Gear Oil74
BLADES75
 Removal And Installation75
BLADE PAN77
 Removal And Installation77
AXLE79
 Wheel Bolts Torque79
 Tire / Wheel Replacement79
 Wheel Bearings79
 Tire Pressure (Aircraft Type)79
CLEANING THE ROTARY CUTTER80
SAFETY SIGN (DECAL) INSTALLATION80
 Procedure80
STORAGE AND RETURN TO SERVICE81
 Storage81
 Return To Service81

Farm King



TROUBLESHOOTING

General Chart



Instructions are necessary before operating or servicing equipment. Read and understand the Operator And Parts Manual and safety signs (decals) on equipment. Follow warnings and instructions in the manuals when making repairs, adjustments or servicing. Check for correct function after adjustments, repairs or service. Untrained operators and failure to follow instructions can cause injury or death.

NOTE: If a problem is encountered that is difficult to solve, even after having read through this troubleshooting section, please call your local distributor or dealer. Before you call, please have this Operator And Parts Manual and the serial number of your machine at hand.

PROBLEM	CAUSE	CORRECTION
Slip clutches slipping under light load.	Scalping the ground.	Raise cutting height.
	Clutch out of adjustment.	Adjust clutch.
	Worn clutch plates	Replace clutch plates.
	Debris or foreign object caught between clutch plate.	Remove foreign object.
PTO driveline failure.	Slip clutch seized.	Adjust or replace slip clutch.
	Shock load.	Avoid blades from contacting solid objects.
	PTO driveline dry.	Lubricate PTO driveline.
Bent PTO driveline shaft.	PTO driveline contacting cutter frame.	Reduce lift height in transport position.
	PTO driveline tractor draw bar.	Re-position draw bar.
	PTO driveline bottoming out.	Shorten driveline.
	PTO driveline binding.	Lubricate PTO driveline.
PTO driveline telescoping tube failure.	Shock load.	Keep blades from contacting solid objects.
PTO driveline telescoping tube wearing.	PTO driveline dry.	Lubricate PTO driveline.
Gearbox seal leaking.	Gearbox over-filled.	Drain excess gear oil from gearbox.
	Damaged or worn seals.	Replace seals.
	Debris wrapped around shaft.	Remove debris and inspect seals. Replace as needed.
Blade carrier damaged.	Shock load.	Keep blades from contacting solid objects.
Excessive skid wear.	Ground contact.	Adjust cutter height.
	Rotary cutter set too low.	Adjust cutter height.

PROBLEM	CAUSE	CORRECTION
Blades do not rotate.	Blades overlapped when wings raised to transport position.	Separate cutting blades before lowering wings.
	Tractor equipped with instant on PTO.	Engage PTO at low RPMs, then slowly increase engine RPMs to full PTO speed.
	Tractor equipped with instant off PTO.	Decrease engine RPMs slowly to an idle before disengaging PTO.
Excessive blade wear.	Operating on sandy ground.	Adjust cutter height.
	Blades contacting the ground.	Adjust cutter height.
Blades loosen during operation.	Blades not tightened correctly.	Tighten blades.
	PTO operating RPMs too high.	Lower RPMs to correct operating speed.
Damaged or breaking blades.	Contacting solid objects.	Keep blades from contacting solid objects.
Blade carrier loose.	Shaft nut loose.	Tighten shaft nut to correct torque.
	Gearbox bearings or shaft damaged.	Replace bearings, shaft or gearbox as needed.
Damaged blade carrier.	Contacting solid objects.	Avoid blades from contacting solid objects.
Wings raise and lower slowly.	Plugged orifice.	Unplug or replace orifice.

Blades

PROBLEM	CAUSE	CORRECTION
Excessive blade wear.	Scalping the ground / contacting solid objects.	Raise cutting height.
Blade bolts loosening.	Blade bolts not torqued properly.	Tighten blade bolts to proper torque.
	Lock nut worn out.	Replace lock nut.
	Cutting in very wet conditions.	Allow work area to dry.
	Cutting too low, scalping ground.	Raise cutting height.
	Cutting too low in rocky conditions.	Raise cutting height.
Blades breaking.	Cutting too low in rocky conditions.	Raise cutting height.
	Damaged or extremely worn blades.	Replace blades.

SERVICE SCHEDULE

Maintenance Intervals

Maintenance work must be done at regular intervals. Failure to do so will result in excessive wear and early failures. The service schedule is a guide for correct maintenance of the 1030 / 1530 Rotary Cutter.



Instructions are necessary before operating or servicing equipment. Read and understand the Operator and Parts Manual and safety signs (decals) on equipment. Follow warnings and instructions in the manuals when making repairs, adjustments or servicing. Check for correct function after adjustments, repairs or service. Untrained operators and failure to follow instructions can cause injury or death.

#	DESCRIPTION	SERVICE PROCEDURES					
		Check	Clean	Lube	Change	Adjust	Drain
Daily Maintenance (or every 8 hours)							
1	Tire Pressure	•					
2	Wheel Bolts	•					
3	Gearbox			•			
4	Splitter			•			
5	PTO Drivelines			•			
6	Blades	•					
7	Blade Pan	•					
8	Rubber Springs	•					
9	All Hardware	•					
10	Guards	•					
Weekly (or every 50 hours)							
11	Axle Bearing	•		•			
12	Adjustable Turnbuckle	•		•			
13	Hitch Frame	•		•			
14	Center Axle	•		•			
15	Wing Axle	•		•			
Annually (or every 500 hours)							
16	Axle Bearings	•		•			
17	Gearbox Oil				•		

LUBRICATION

Recommendations

Always use a good quality multi-purpose / lithium base grease when lubricating the equipment.



Do not over-grease bearings. Greasing too often can damage seals and lead to premature bearing failure.

- Always use a hand-held grease gun.
- Clean fitting before greasing, to avoid injecting dirt and grit.
- Replace and repair broken fittings immediately.
- If fittings will not take grease, remove and clean thoroughly. Replace fitting if necessary.

Locations



Fluid such as engine oil, hydraulic fluid, coolants, grease, etc. must be disposed of in an environmentally safe manner. Some regulations require that certain spills and leaks on the ground must be cleaned in a specific manner. See local, state and federal regulations for the correct disposal.

Lubricate the following grease locations EVERY 8 HOURS:

Figure 38

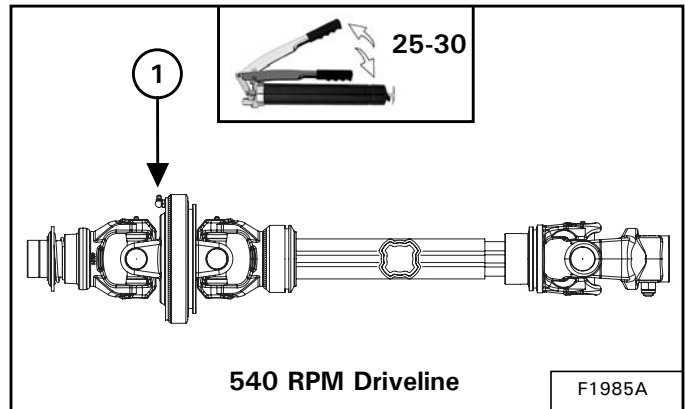

Apply 25-30 pumps of grease to CV (Constant Velocity) body (Item 1) [Figure 38].

Figure 39

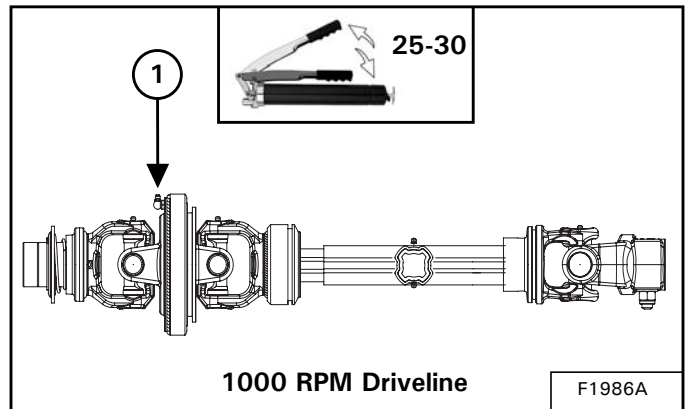

Apply 25-30 pumps of grease to CV (Constant Velocity) body (Item 1) [Figure 39].

Lubricate the following grease locations EVERY 8 HOURS:

Figure 40

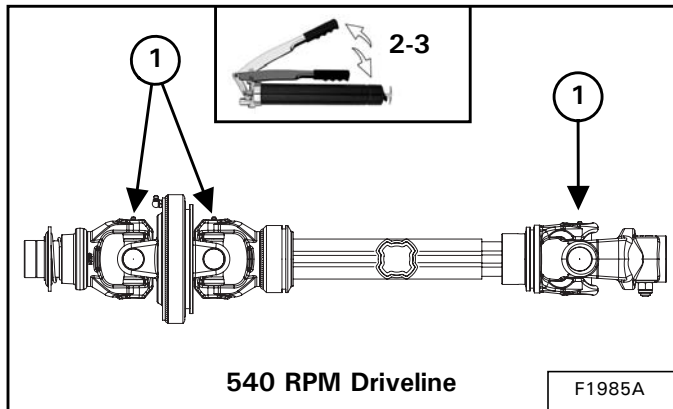

Apply two - three pumps of grease to the u-joints (Item 1) [Figure 40].

Figure 41

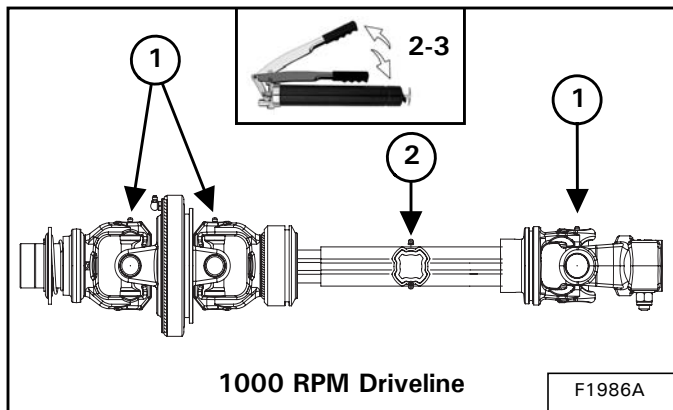

Apply two - three pumps of grease to the u-joints (Item 1) and shaft (Item 2) [Figure 41].

Figure 42

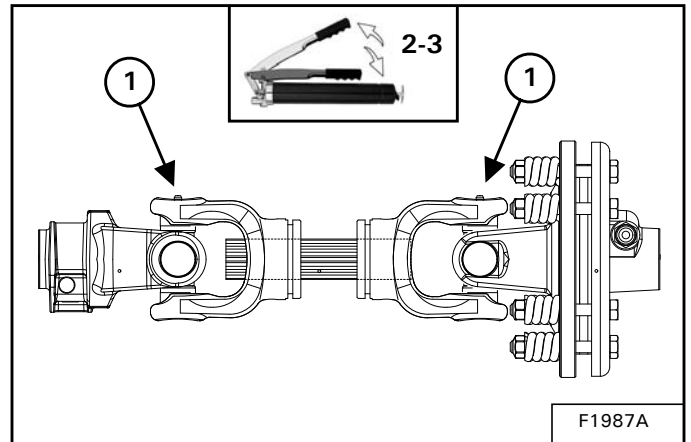

Apply two - three pumps of grease to the u-joints (Item 1) [Figure 42] of the slip clutch driveline.

Figure 43

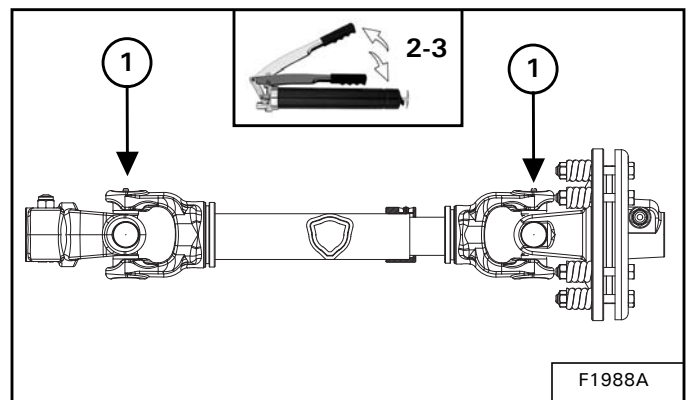

Apply two - three pumps of grease to u-joints (Item 1) [Figure 43] of the splitter driveline.

Figure 44

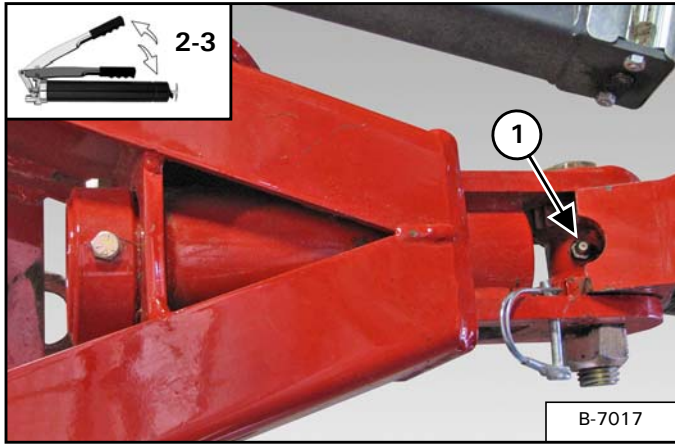

Apply two - three pumps of grease to the clevis pivot (Item 1) [Figure 44].

Figure 46

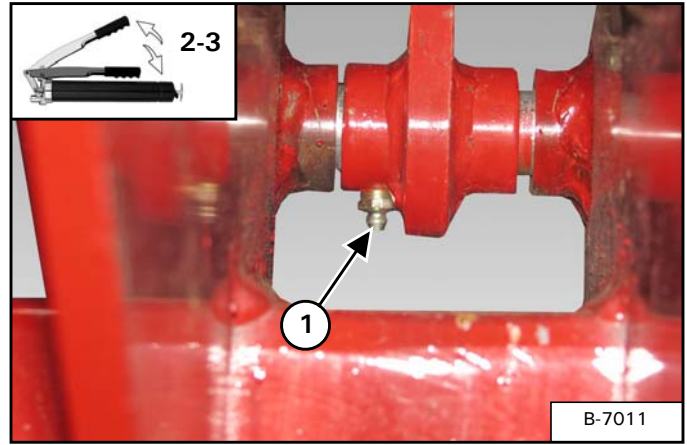

Apply two - three pumps of grease to the axle pivots (Item 1) [Figure 46] (LH & RH locations).

Figure 45

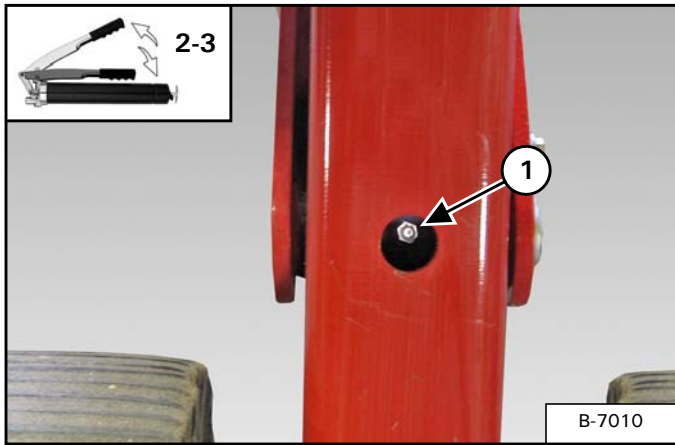

Apply two - three pumps of grease to the suspension arm (Item 1) [Figure 45] (all locations).

Figure 47

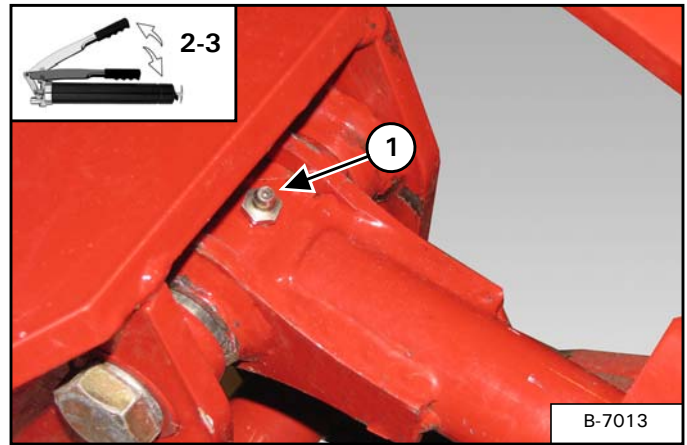

Apply two - three pumps of grease to the center axle pivots (Item 1) [Figure 47].

Figure 48

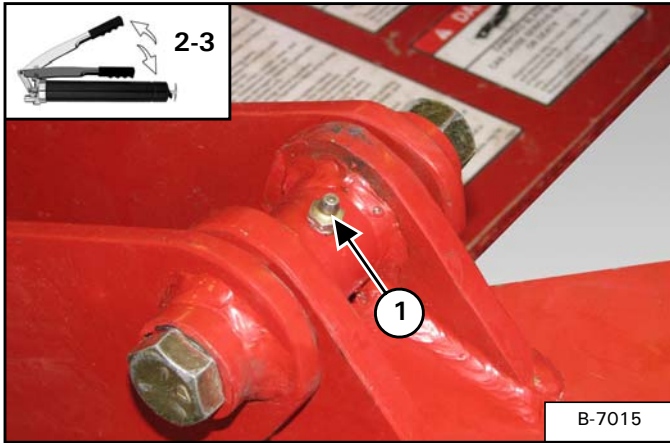

Apply two - three pumps of grease to the hitch pivot pin (Item 1) [Figure 48] (both sides).

Figure 49

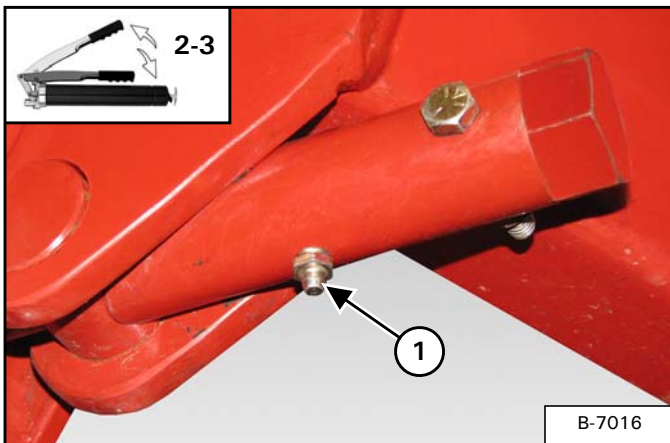

Apply two - three pumps of grease to the adjustment rod (Item 1) [Figure 49].

Figure 50

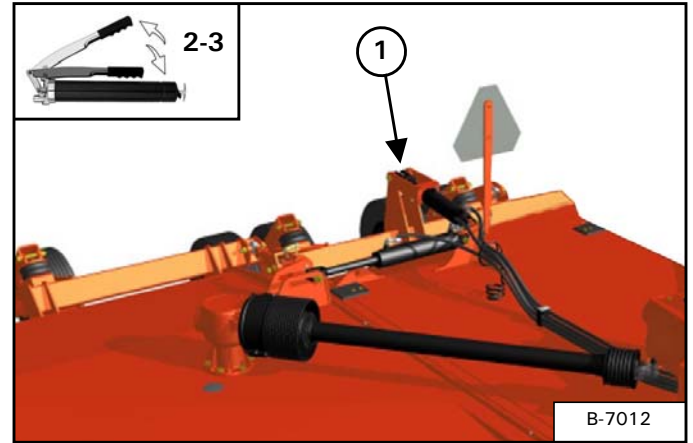

Apply two - three pumps of grease to the turnbuckle (Item 1) [Figure 50] (both locations).

Figure 51

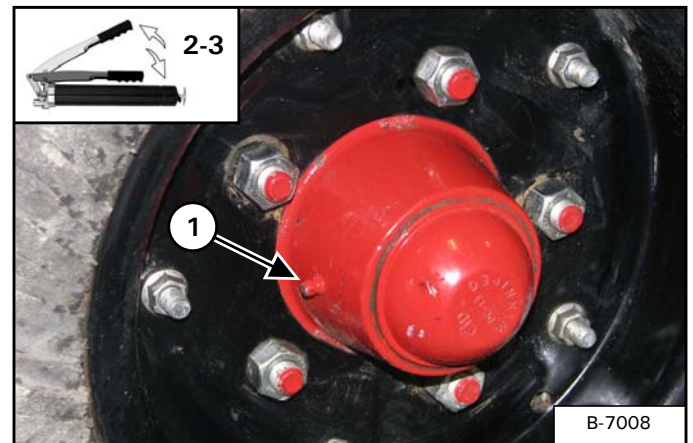

Apply two - three pumps of grease to the wheel bearing (Item 1) [Figure 51].

SPLITTER GEARBOX

Checking Gear Oil Level

Park the tractor and Rotary Cutter on a flat level surface.



Allow gear oil to settle into the bottom cavity of the gearbox for approximately 15-20 min. before checking level on dipstick.

Figure 52

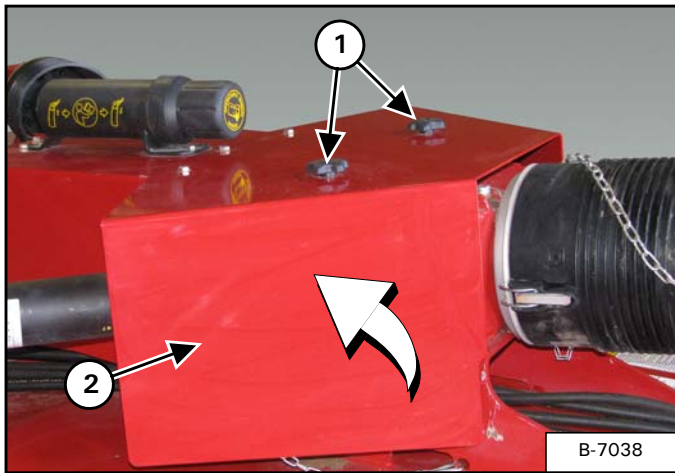

Remove the two knobs (Item 1) and rotate guards (Item 2) [Figure 52] to the rear.

Figure 53

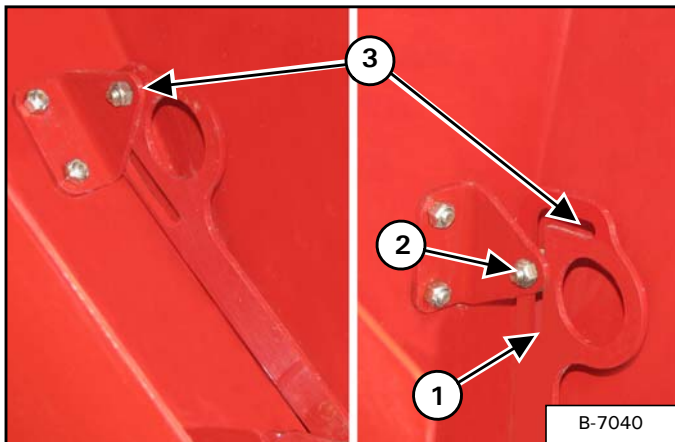

Rotate guards allowing latch plate (Item 1) to slide on the latch bolt (Item 2) and into the vertical slot (Item

3) [Figure 53] on the latch plate holding the guards open.

Figure 54

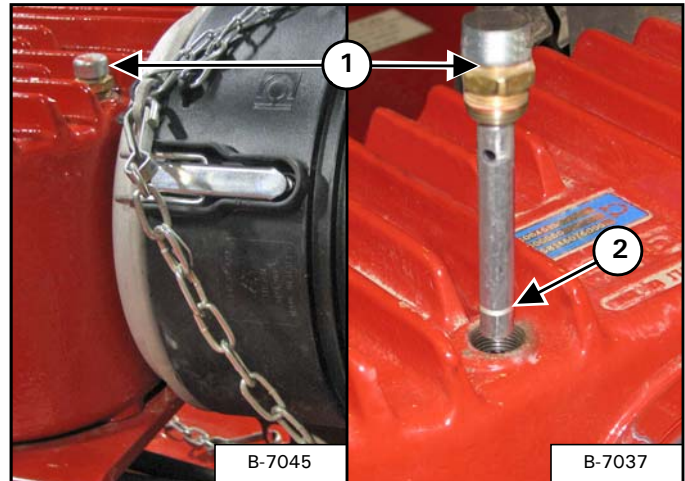

NOTE: To get an accurate reading of oil level, do not screw in the dipstick.

Remove dipstick / vent plug (Item 1) [Figure 54].

Wipe the dipstick clean. Place the dipstick back into the splitter gearbox until the dipstick makes contact with the splitter gearbox. Pull dipstick out and check gear oil level.

The gear oil level should be at the fill line (Item 2) [Figure 54].

Add SAE 80W-90 gear oil until oil reaches the dipstick fill line (Item 2). Install and tighten dipstick / vent plug (Item 1) [Figure 54].



Wait approximately 15-20 min. after filling the splitter gearbox to allow gear oil to settle into the bottom cavity before checking level on dipstick.

Changing Gear Oil



Replace the gear oil in new gearboxes after first 50 hours of operation. Then replace the gear oil annually.

Park the tractor and Rotary Cutter on a flat level surface.

Leave the operator's position. (See "Leaving The Operator's Position" on page 39.)



Always wear proper hand and eye protection when servicing the implement.

Figure 55

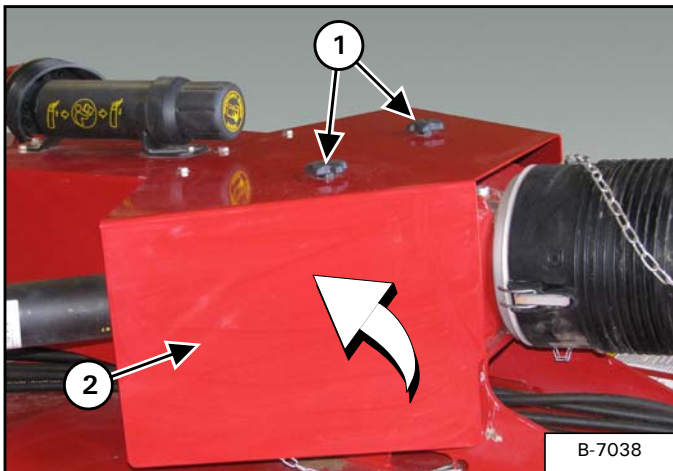

Remove the two knobs (Item 1) and rotate guards (Item 2) [Figure 55] to the rear.

Figure 56

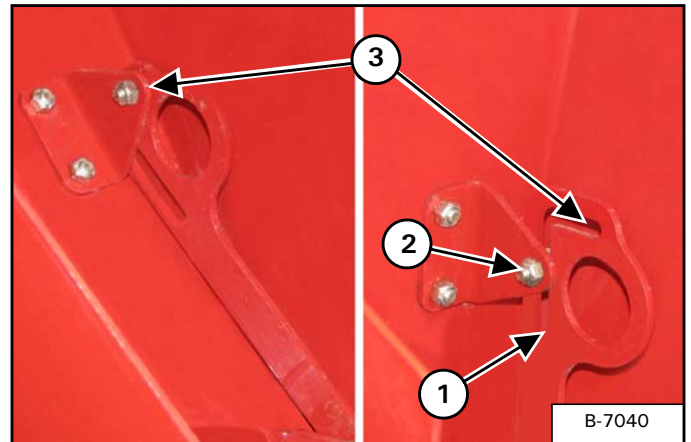

Rotate guards allowing latch plate (Item 1) to slide on the latch bolt (Item 2) and into the vertical slot (Item 3) [Figure 56] on the latch plate holding the guards open.

Figure 57

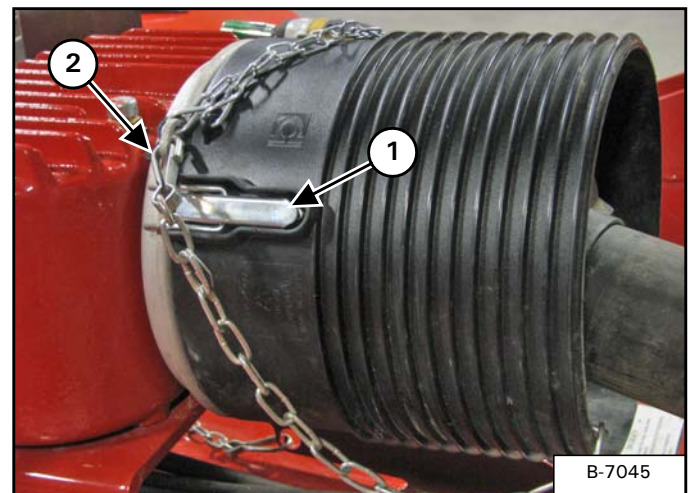

Release PTO driveline guard latches (Item 1) and disconnect safety chain (Item 2) [Figure 57]. Slide PTO driveline guard away from splitter gearbox.

Figure 58

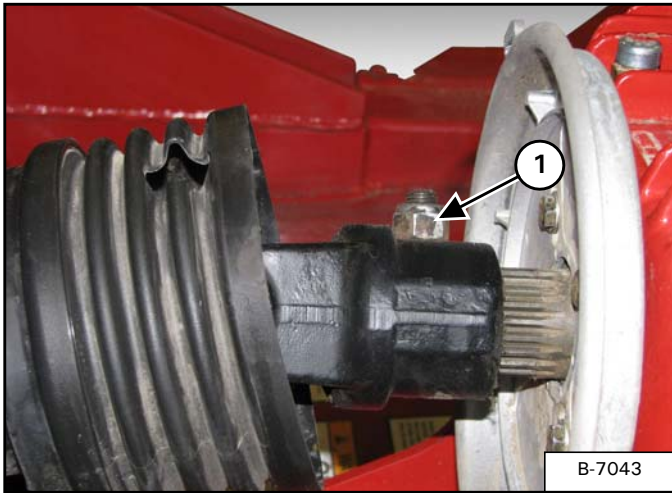

Remove lock nut (Item 1) [Figure 58] and bolt. Remove driveline from splitter gearbox shaft.

Figure 59

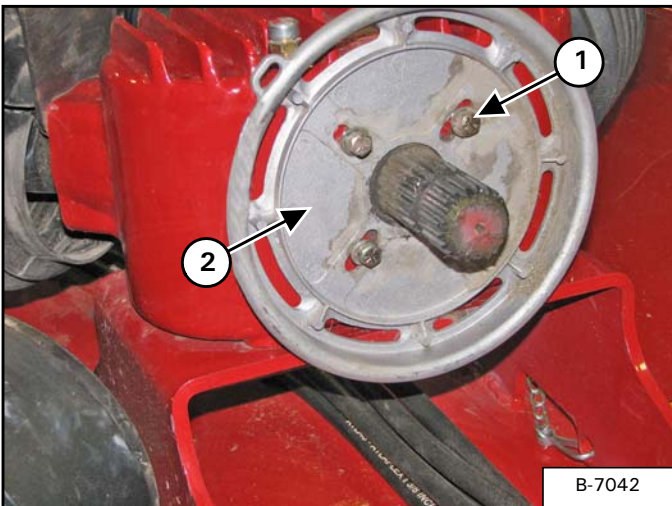

Remove the four 5/16" x 3/4" bolts and flat washers (Item 1). Remove guard plate (Item 2) [Figure 59].

! IMPORTANT

Fluid such as engine oil, hydraulic fluid, coolants, grease, etc. must be disposed of in an environmentally safe manner. Some regulations require that certain spills and leaks on the ground must be cleaned in a specific manner. See local, state and federal regulations for the correct disposal.

Figure 60

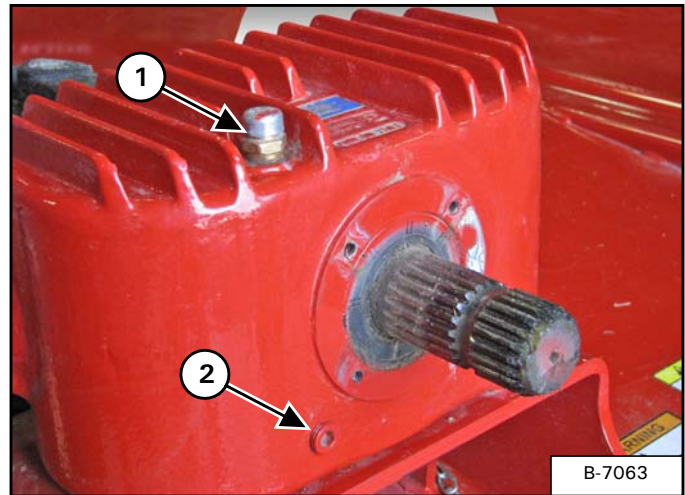

Remove dipstick / vent plug (Item 1) [Figure 60].

Place a collection container under the drain plug (Item 2) [Figure 60]. Remove drain plug and drain the gear oil into the collection container.

Once the oil is drained, install the drain plug.

Figure 61

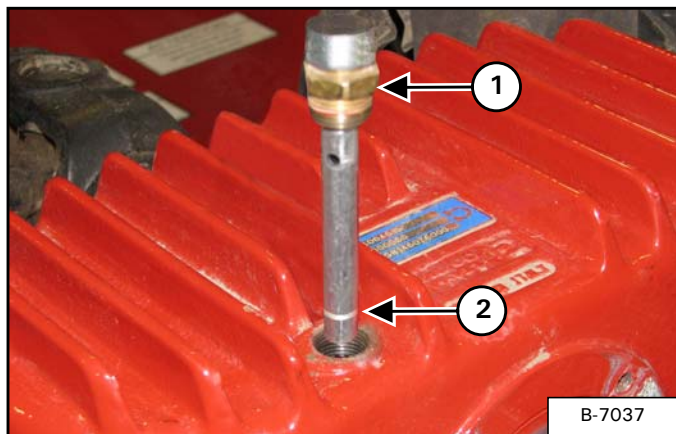

Add SAE 80W-90 gear oil until oil reaches the dipstick fill line (Item 2). Install and tighten dipstick / vent plug (Item 1) [Figure 61].

The gear oil level should be at the fill line (Item 2) [Figure 61].

Place the dipstick / vent plug (Item 1) [Figure 61] back into the splitter gearbox until the dipstick makes contact with the splitter gearbox. Pull dipstick out and check gear oil level.

Once gear oil reaches the fill line, install and tighten the dipstick / vent plug.

Figure 62

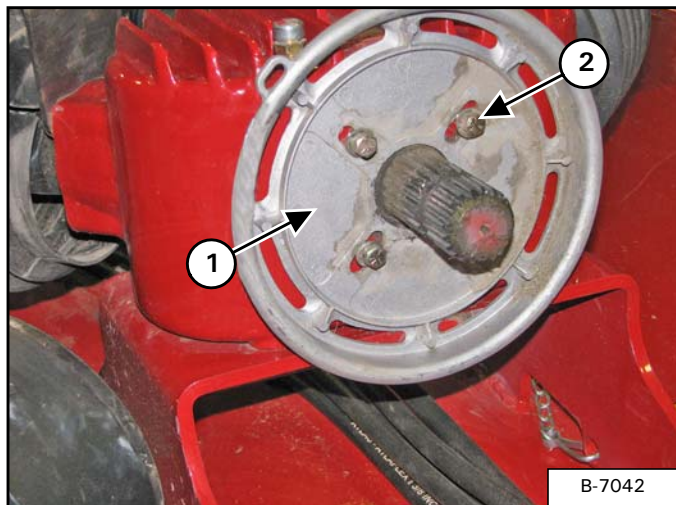

Align the guard plate (Item 1) with the mounting holes on the splitter gearbox. Install and tighten four 5/16" x 3/4" bolts and 5/16" flat washers (Item 2) [Figure 62] through the guard plate and into the splitter gear box.

Figure 63

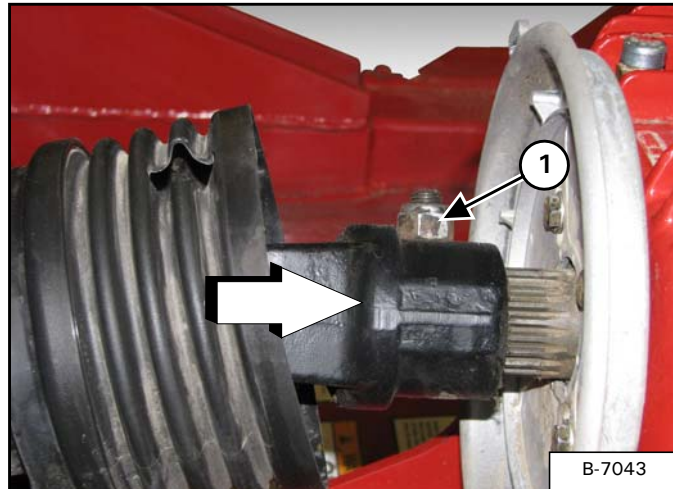

Slide PTO driveline onto the splitter gearbox shaft. Align PTO driveline and shaft bolt holes. Install bolt and lock nut (Item 1) [Figure 63] and bolt. Tighten until lock nut makes contact with the PTO driveline collar.

Figure 64

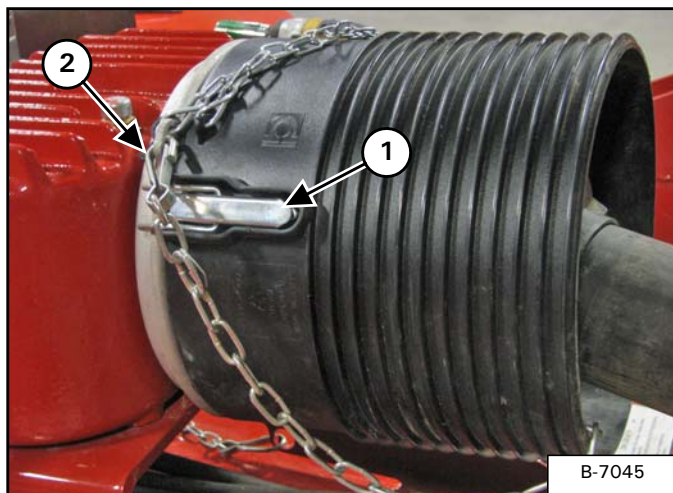

Slide PTO guard over the guard plate. Hook latches (Item 1) to secure the PTO guard to the guard plate. Connect safety chain (Item 2) [Figure 64] to the guard plate.

RIGHT ANGLE GEARBOX

Checking Gear Oil Level

Park the tractor and Rotary Cutter on a flat level surface.

! IMPORTANT

Allow gear oil to settle into the bottom cavity of the gearbox for approximately 15-20 min. before checking level on dipstick.

Figure 65

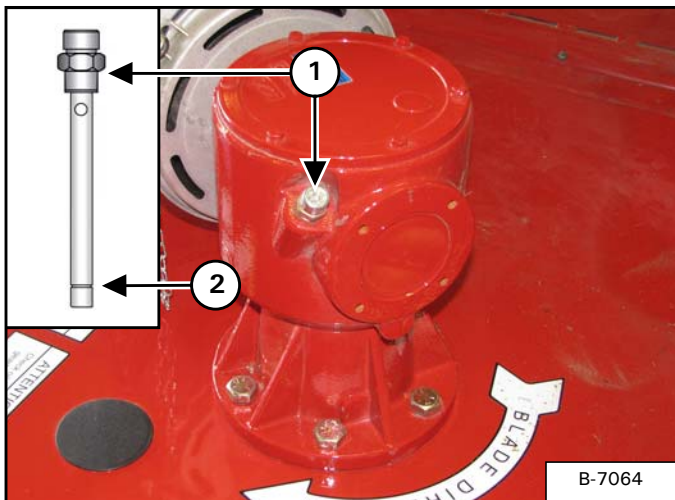

NOTE: To get an accurate reading of oil level, do not screw in the dipstick.

Remove dipstick / vent plug (Item 1) [Figure 65].

Wipe the dipstick clean. Place the dipstick back into the gearbox until the dipstick makes contact with the gearbox. Pull dipstick out and check gear oil level.

The gear oil level should be at the fill line (Item 2) [Figure 65].

Add SAE 80W-90 gear oil until oil reaches the dipstick fill line (Item 2). Install and tighten dipstick / vent plug (Item 1) [Figure 65].

Changing Gear Oil

! IMPORTANT

Replace the gear oil in new gearboxes after first 50 hours of operation. Then replace the gear oil annually.

Park the tractor and Rotary Cutter on a flat level surface.

Leave the operator's position. (See "Leaving The Operator's Position" on page 39.)

! WARNING

Always wear proper hand and eye protection when servicing the implement.

! IMPORTANT

Fluid such as engine oil, hydraulic fluid, coolants, grease, etc. must be disposed of in an environmentally safe manner. Some regulations require that certain spills and leaks on the ground must be cleaned in a specific manner. See local, state and federal regulations for the correct disposal.

Figure 66

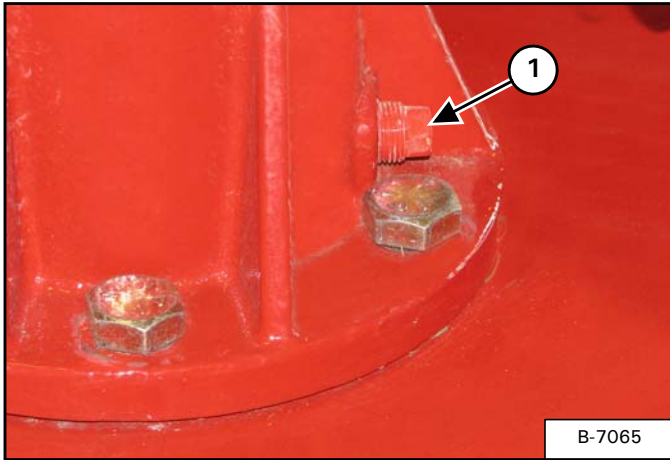

Place a collection container under the drain plug (Item 1) [Figure 66]. Remove drain plug and drain the gear oil into the collection container.

Once the oil is drained, install the drain plug.

Figure 67

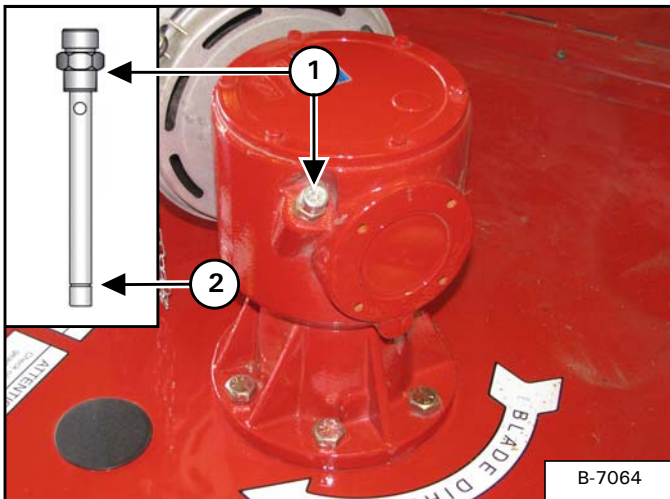

NOTE: To get an accurate reading of oil level, do not screw in the dipstick.

Remove dipstick / vent plug (Item 1) [Figure 67].

Wipe the dipstick clean. Place the dipstick back into the gearbox until the dipstick makes contact with the gearbox. Pull dipstick out and check gear oil level.

The gear oil level should be at the fill line (Item 2) [Figure 67].

Add SAE 80W-90 gear oil until oil reaches the dipstick fill line (Item 2). Install and tighten dipstick / vent plug (Item 1) [Figure 67].

BLADES

Removal And Installation

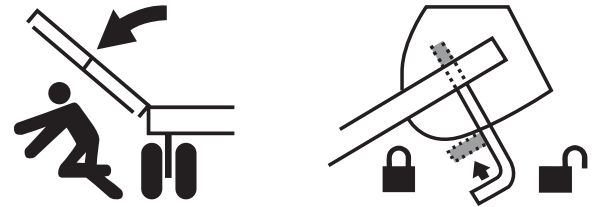

FALLING WING CAN CAUSE SERIOUS INJURY OR DEATH

- Always secure wing transport locks before transporting, servicing, or parking the cutter.
- Stand clear when lowering or raising wings.

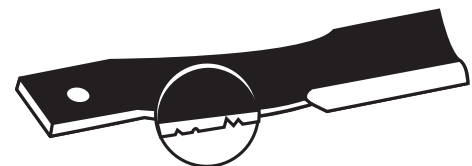

DAMAGED BLADES CAN CAUSE SERIOUS INJURY OR DEATH

- Inspect blades daily for chips, cracks, wear and abnormal bends.
- Do Not modify blades in any way such as sharpening, straightening or welding.
- Replace blades with genuine Farm King blades only.
- Unbalanced blades are dangerous.
- Replace blades in pairs.

! IMPORTANT

- Inspect blades and blade hardware daily for tightness.
- Tighten blade mounting hardware to 765 ft-lb (1037 N•m) torque.
- Always install new blade mounting hardware every time blades are replaced.

Enter the tractor, start the engine and engage the tractor’s hydraulics.

Run the tractor engine at low idle. Using the tractor’s hydraulic controls, fully raise the center deck, then fully raise the wings.

Stop the tractor, engage the parking brake and turn the engine off.

Leave the operator’s position. (See “Entering And Leaving The Operator’s Position” on page 39.)

Lock wings in the transport position. (See “Wing Transport Locks” on page 41.)

Engage the frame lock. (See “Frame Lock” on page 40.)

Figure 68

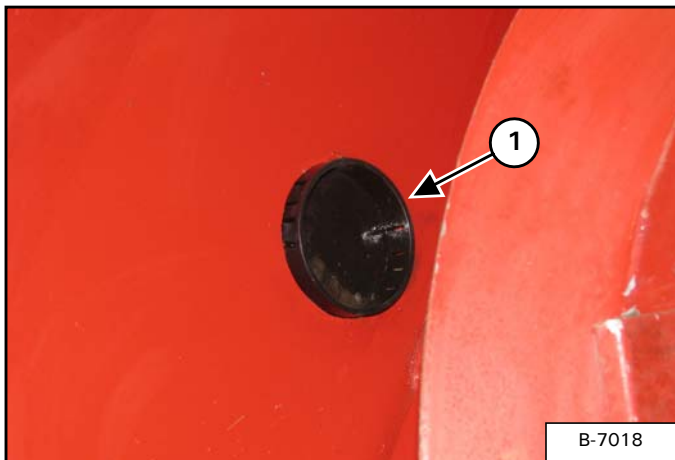

Remove access plug (Item 1) [Figure 68] from the deck (above blades to be replaced).

Figure 69

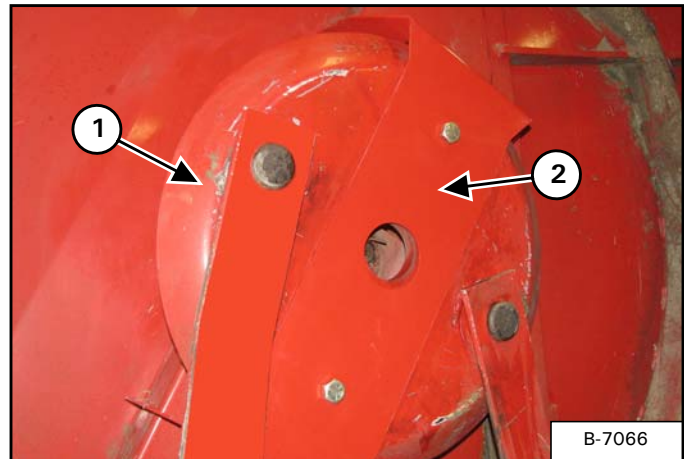

Rotate the blade pan (Item 1) [Figure 69] until the desired blade hardware is visible through the access hole in the deck.

Install the blade pan locking bracket (Item 2) [Figure 69] over the blade pan and between the blades.

Figure 70

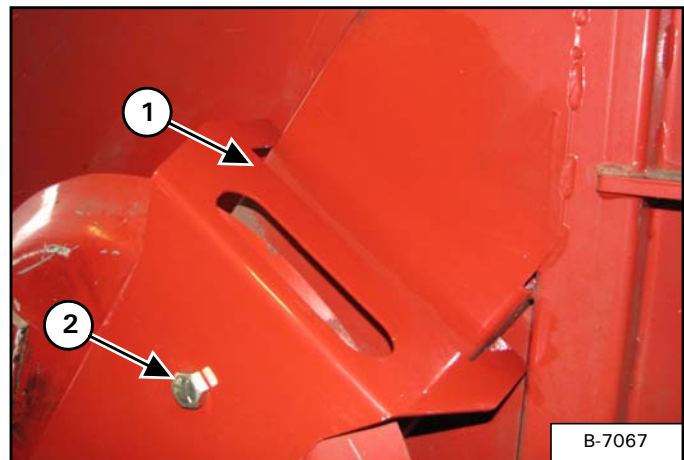

Position the blade pan locking bracket (Item 1) over the support on the under side of the deck. Secure the blade pan locking bracket in place with two 3/4” x 1-1/2” bolts (Item 2) [Figure 70], 3/4” flat washers, and 3/4” nuts.

Remove blade nut by placing wrench through the access hole of the deck. Remove blade bolt and blade.

Align new blade with the mounting hole. Using a hammer, tap the new blade bolt in place (flush against blade pan). Install a new blade nut and tighten to 765 ft-lb (1037 N•m) torque.

Repeat as needed until the desired blades have been replaced.

BLADE PAN

Removal And Installation

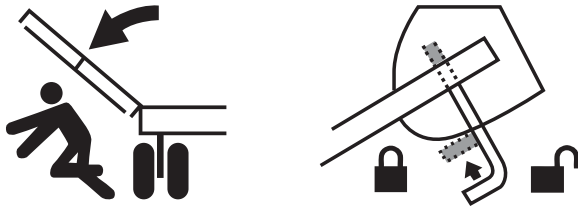

FALLING WING CAN CAUSE SERIOUS INJURY OR DEATH

- Always secure wing transport locks before transporting, servicing, or parking the cutter.
- Stand clear when lowering or raising wings.

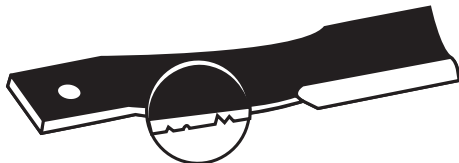

DAMAGED BLADES CAN CAUSE SERIOUS INJURY OR DEATH

- Inspect blades daily for chips, cracks, wear and abnormal bends.
- Do Not modify blades in any way such as sharpening, straightening or welding.
- Replace blades with genuine Farm King blades only.
- Unbalanced blades are dangerous.
- Replace blades in pairs.



- Inspect blades and blade hardware daily for tightness.
- Tighten blade mounting hardware to 765 ft-lb (1037 N•m) torque.
- Always install new blade mounting hardware every time blades are replaced.

Enter the tractor, start the engine and engage the tractor’s hydraulics.

Run the tractor engine at low idle. Using the tractor’s hydraulic controls, fully raise the center deck, then fully raise the wings.

Stop the tractor, engage the parking brake and turn the engine off.

Leave the operator’s position. (See “Entering And Leaving The Operator’s Position” on page 39.)

Lock wings in the transport position. (See “Wing Transport Locks” on page 41.)

Engage the frame lock. (See “Frame Lock” on page 40.)

Figure 71

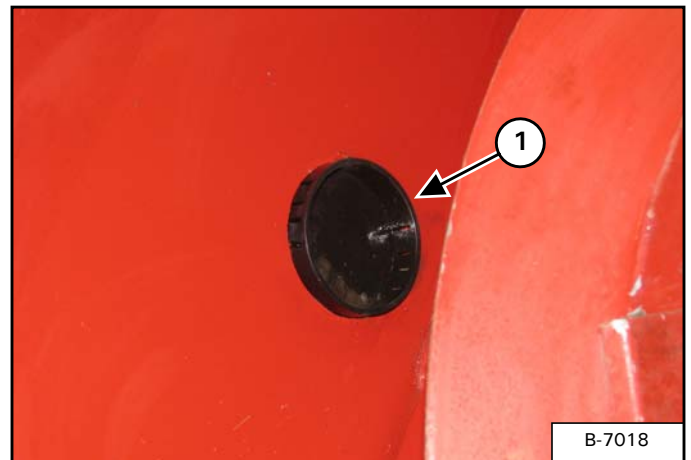

Remove access plug (Item 1) [Figure 71] from the deck (above blades to be replaced).

Figure 72

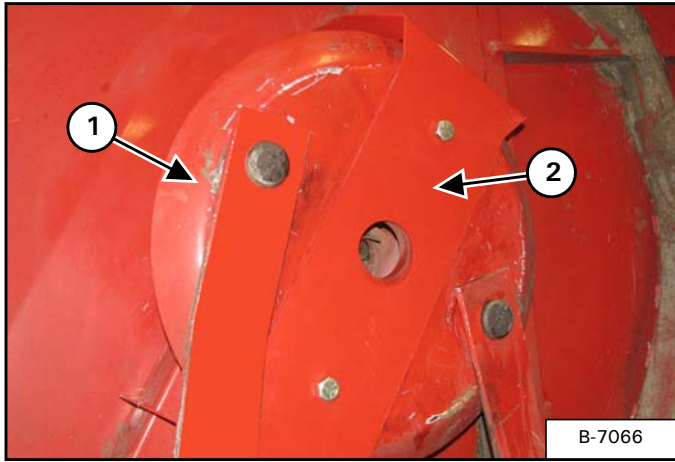

Rotate the blade pan (Item 1) [Figure 72] until the desired blade hardware is visible through the access hole in the deck.

Install the blade pan locking bracket (Item 2) [Figure 72] over the blade pan and between the blades.

Figure 73

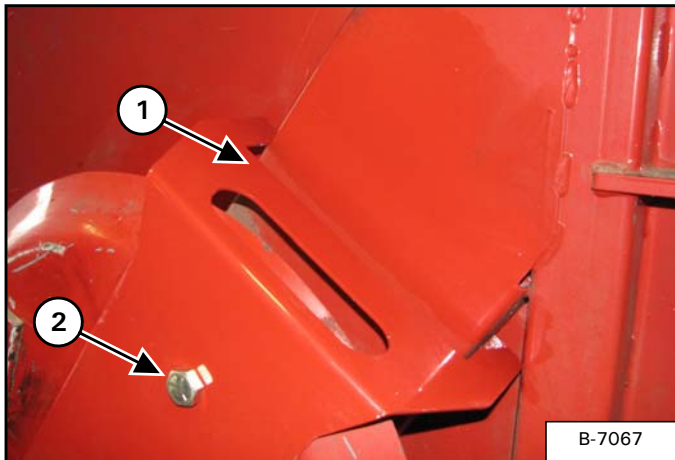

Position the blade pan locking bracket (Item 1) over the support on the under side of the deck. Secure the blade pan locking bracket in place with two 3/4" x 1-1/2" bolts (Item 2) [Figure 73], 3/4" flatwashers, and 3/4" nuts.

Remove one blade nut by placing wrench through the access hole of the deck. Remove blade bolt and blade.

Remove blade pan locking bracket.

Rotate blade pan and align second blade hardware. Re-install blade pan locking bracket.

Remove second blade nut, bolt and blade. Remove blade pan locking bracket and blade pan.

Figure 74

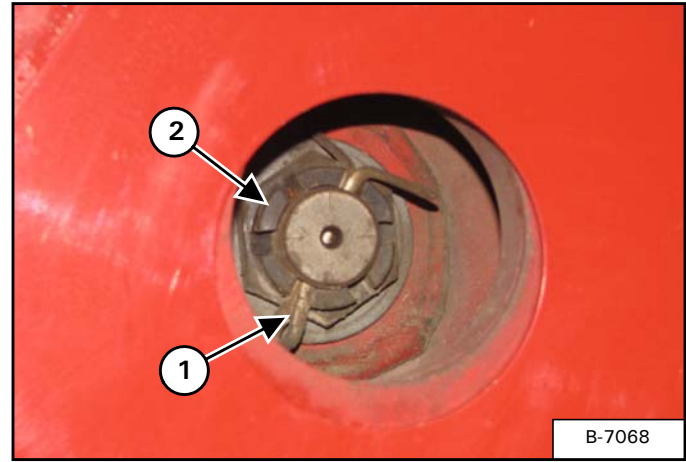

Remove cotter pin (Item 1) and castle nut (Item 2) [Figure 74]. Remove blade pan.

Align new blade pan with the gearbox shaft.

Install castle nut (Item 2) [Figure 74]. Tighten castle nut to 480 ft. lb. (651 N•m) torque.

Install cotter pin (Item 1) [Figure 74].

Re-install blade pan locking bracket.

Align one new blade with the mounting hole. Using a hammer, tap the new blade bolt in place (flush against blade pan). Install a new blade nut and tighten to 765 ft. lb. (1037 N•m) torque.

Remove blade pan locking bracket.

Rotate blade pan to align second blade hardware.

Re-install blade pan locking bracket.

Align second new blade with the mounting hole. Using a hammer, tap the new blade bolt in place (flush against blade pan). Install a new blade nut and tighten to 765 ft. lb. (1037 N•m) torque.

AXLE

Wheel Bolts Torque

Check the torque on wheel bolts daily. Tighten wheel bolts to 93 ft. lb. (126 N•m) torque.

Tire / Wheel Replacement



AVOID INJURY OR DEATH

Before you leave the operator’s position:

- Always park on a flat level surface.
- Place all controls in **NEUTRAL**.
- Engage the park brake.
- Stop the engine and remove the key.
- Wait for all moving parts to stop.

Park the tractor / equipment on a flat level surface.

Place all controls in neutral, engage the park brake, stop the engine and wait for all moving parts to stop. Leave the operator’s position.



AVOID INJURY OR DEATH

- The parking brake must be engaged before leaving the operator’s position. Rollaway can occur because the transmission may not prevent machine movement.
- Always chock tires before performing any maintenance or service.

Place chock blocks behind and in front of the opposite tire to be removed.

Place a jack under the axle frame close to the tire / wheel being replaced. Raise the jack until the tire / wheel is slightly off the ground.

NOTE: Place blocks under the frame to help secure the Rotary Cutter when tire / wheel is raised off the ground.

Remove the five wheel nuts and remove the tire / wheel.

Figure 75

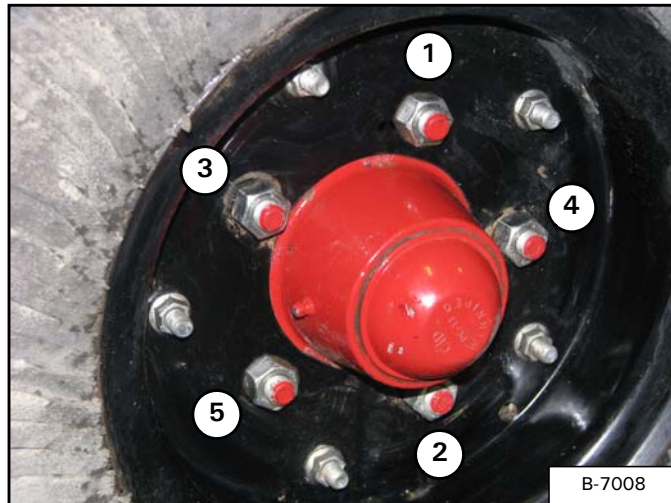

Install the five wheel nuts (Items 1 - 5) [Figure 75].

Tighten wheel bolts in a criss-cross pattern [Figure 75]. Tighten wheel bolts to 93 ft. lb. (126 N•m) of torque.

Wheel Bearings

Inspect and re-pack the wheel bearings annually with a quality SAE multi purpose type grease.

Tire Pressure (Aircraft Type)



When inflating tires, use a clip-on chuck and extension hose long enough to allow you to stand to one side and NOT in front of or over the tire assembly.

Check tire pressure daily. Fill tires to 40 psi (276 kPa).

CLEANING THE ROTARY CUTTER

Fully Clean the Rotary Cutter DAILY:



AVOID COMPONENT DAMAGE

- Remove all debris around and under the PTO drivelines.
- Remove all debris around the gearboxes, blade pans and blades.

SAFETY SIGN (DECAL) INSTALLATION

Procedure



When replacing safety signs (decals), the temperature must be above 10° C (50° F).

- Remove all portions of the damaged safety sign (decal).
- Thoroughly clean the area with glass cleaner. Remove all adhesive residue.
- Allow the area to dry completely before installing the new safety sign (decal).
- Position the safety sign (decal) in the correct location. Remove a small portion of the backing paper on the safety sign (decal).
- Press on the safety sign (decal) where the backing paper has been removed.
- Slowly remove the remaining backing paper, pressing on the safety sign (decal) as the backing paper is removed.
- Using the backing paper, pressing firmly, move the backing paper over the entire safety sign (decal) area.

NOTE: Small air pockets can be pierced with a pin and smoothed out using the piece of the backing paper.

STORAGE AND RETURN TO SERVICE

Storage

Sometimes it may be necessary to store your Farm King Rotary Cutter for an extended period of time. Below is a list of items to perform before storage.



DO NOT permit children to play on or around the stored machine.

- Thoroughly clean the equipment.
- Lubricate the equipment.
- Inspect the hitch and all welds on the equipment for wear and damage.
- Check for loose hardware, missing guards, or damaged parts.
- Check for damaged or missing safety signs (decals). Replace if necessary.
- Replace worn or damaged parts.
- Touch up all paint nicks and scratches to prevent rusting.
- Store the Rotary Cutter in a clean, dry, sheltered area.
- Place the equipment flat on the ground.

Return To Service

After the Farm King Rotary Cutter has been in storage, it is necessary to follow a list of items to return the equipment to service.

- Be sure all shields and guards are in place.
- Lubricate the equipment.
- Inspect and repack wheel bearings with a SAE multi purpose type grease.
- Check that tires / wheels are in good operating condition and wheel nuts are tightened to the proper torque.
- Connect to a tractor and operate equipment, verify all functions operate correctly.
- Check for leaks. Repair as needed.
- Review the Operator's Manual.

Farm King



PARTS IDENTIFICATION

GENERAL INFORMATION85

BASE FRAME85

 Rotary Cutter Assembly - 103085

 Left Wing Ballast Assembly - 103086

 Rotary Cutter Assembly - 153087

 Hitch Assembly88

 Center Deck Assembly - 103090

 Center Deck Assembly - 153096

 Deck Hinge Assembly102

 LH Wing Deck Assembly104

 RH Wing Deck Assembly106

 Chain Kit Assembly108

 Front Wing Chain Holder Assembly (# 915542)109

 Rear Wing Chain Holder Assembly (# 915543)109

 Rear Wing Short Chain Holder Assembly (# 916310)109

 Front Middle Chain Guard Assembly (#916282)109

 Rear Middle Chain Guard Assembly (# 915763)109

 Front Middle Double Chain Holder Assembly (# 923912)111

 Rear Middle Double Chain Holder Assembly (# 923913)111

 Rear Wing Short Double Chain Holder Assembly (# 923938)111

 Front Wing Double Chain Guard Assembly (#923939)111

 Rear Wing Double Chain Guard Assembly (# 923940)111

AXLE112

 Laminated Tire Assembly - 1030112

 Laminated Tire Assembly - 1530112

 Aircraft Tire Assembly - 1030113

 Aircraft Tire Assembly - 1530113

 LH Axle Assembly - 1530114

 RH Axle Assembly115

 Center Axle Assembly116

 Double Spindle Assembly118

 LH Single Spindle Assembly119

 RH Single Spindle Assembly120

 LH Walking Axle Assembly121

 RH Walking Axle Assembly122

DRIVELINE, HYDRAULICS, LIGHT KIT, OTHER123

 Driveline 540 RPM123

 Driveline 1000 RPM124

 Wing Driveline125

 Slip Clutch Driveline126

 Hydraulic Pressure Line Assembly - 1030128

Hydraulic Pressure Line Assembly - 1530	130
Light Kit Assembly	132
Lock Bracket W/ Stump Jumper / Blades Assembly	133
Cat 2 Clevis Hitch Assembly	134
Cat 2 Precision Hitch Assembly	135

GENERAL INFORMATION

The parts identification section lists descriptions, part numbers and quantities for the Rotary Cutter 1030 & 1530. Contact your Farm King dealer for additional Rotary Cutter 1030 & 1530 parts information.

BASE FRAME

Rotary Cutter Assembly - 1030

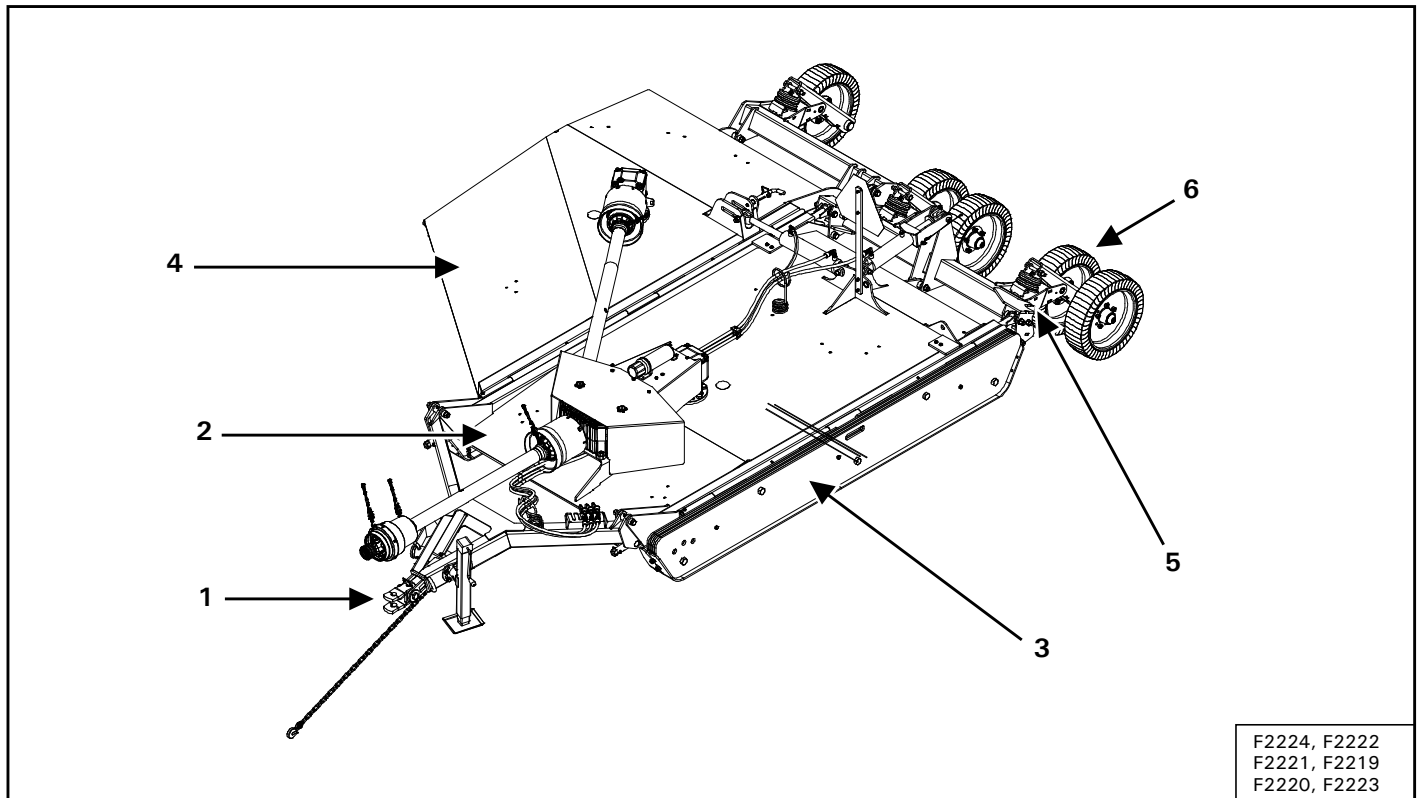

ITEM	PART NUMBER		DESCRIPTION
	540 PTO	1000 PTO	
1	F2358		HITCH ASSEMBLY
2	F2350	F2351	CENTER DECK ASSEMBLY
3	F2115		LH WING BALLAST ASSEMBLY
4	F2354	F2355	RH WING DECK ASSEMBLY
5	923942		LH SINGLE SPINDLE ASSEMBLY
	923943		RH SINGLE SPINDLE ASSEMBLY
	916205		DOUBLE SPINDLE ASSEMBLY
	923829		LH WALKING AXLE ASSEMBLY
	923880		RH WALKING AXLE ASSEMBLY
6	F1989		LAMINATED WHEEL ASSEMBLY
	F1990		AIRCRAFT WHEEL ASSEMBLY

Left Wing Ballast Assembly - 1030

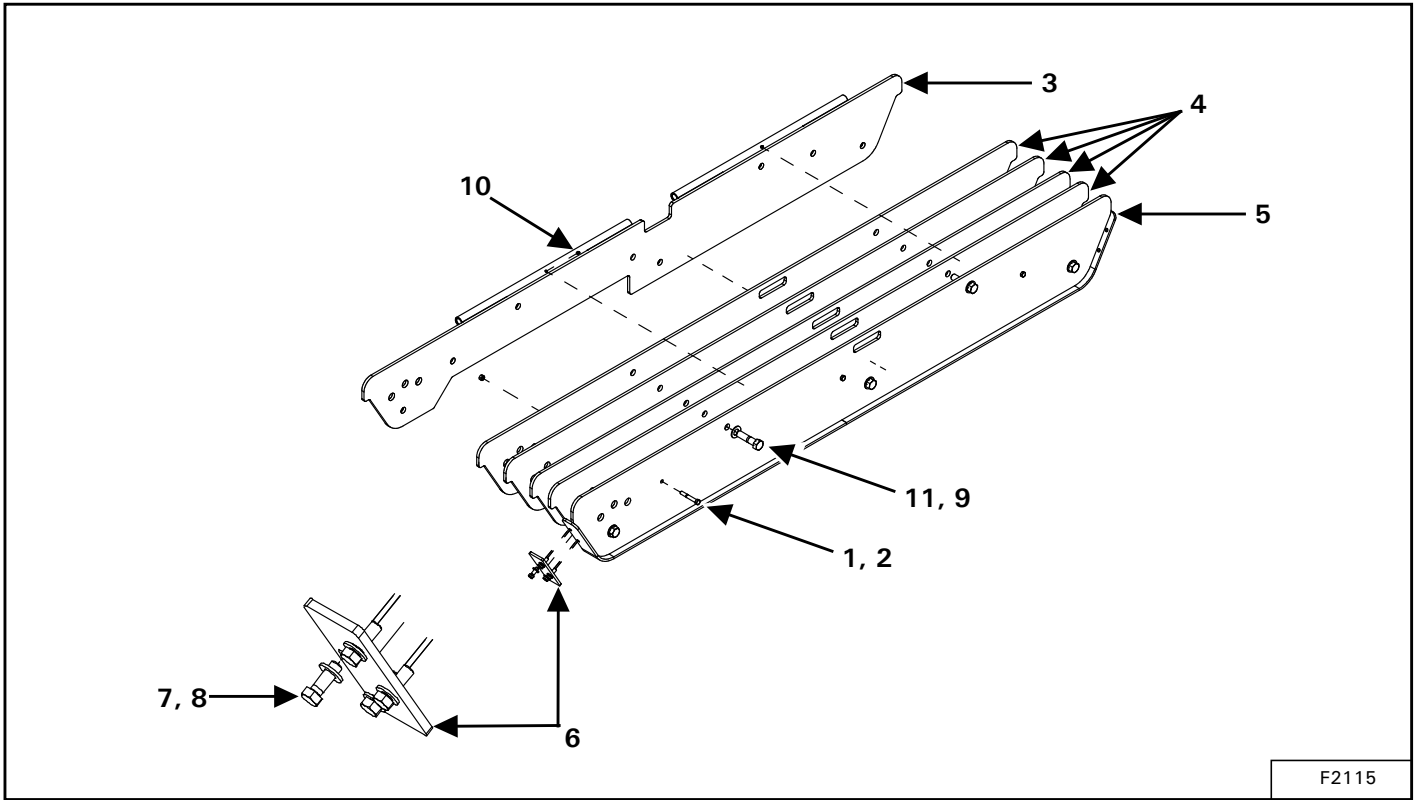

ITEM	PART NUMBER	DESCRIPTION	QTY
1	81629	BOLT, 1/2" x 3-1/2" HEX (PL)	3
2	81636	NUT, 1/2" HEX (PL)	3
3	818254	LEFT WING WELDMENT	1
4	818255L	INNER BALLAST PLATE	4
5	818263	SKID SHOE WING WELDMENT	1
6	818341	SKID SUPPORT WELDMENT	1
7	84048	FLAT WASHER, 1/2" SAE (PL)	4
8	84277	BOLT, 1/2" x 1-1/2" HEX (PL)	4
9	84522	FLAT WASHER, 1" ID SAE (PL)	5
10	967164	DRIVE-IN GREASE ZERK	2
11	818588	BOLT, 1" X 4.5" HEX GR5 (PL)	5

Rotary Cutter Assembly - 1530

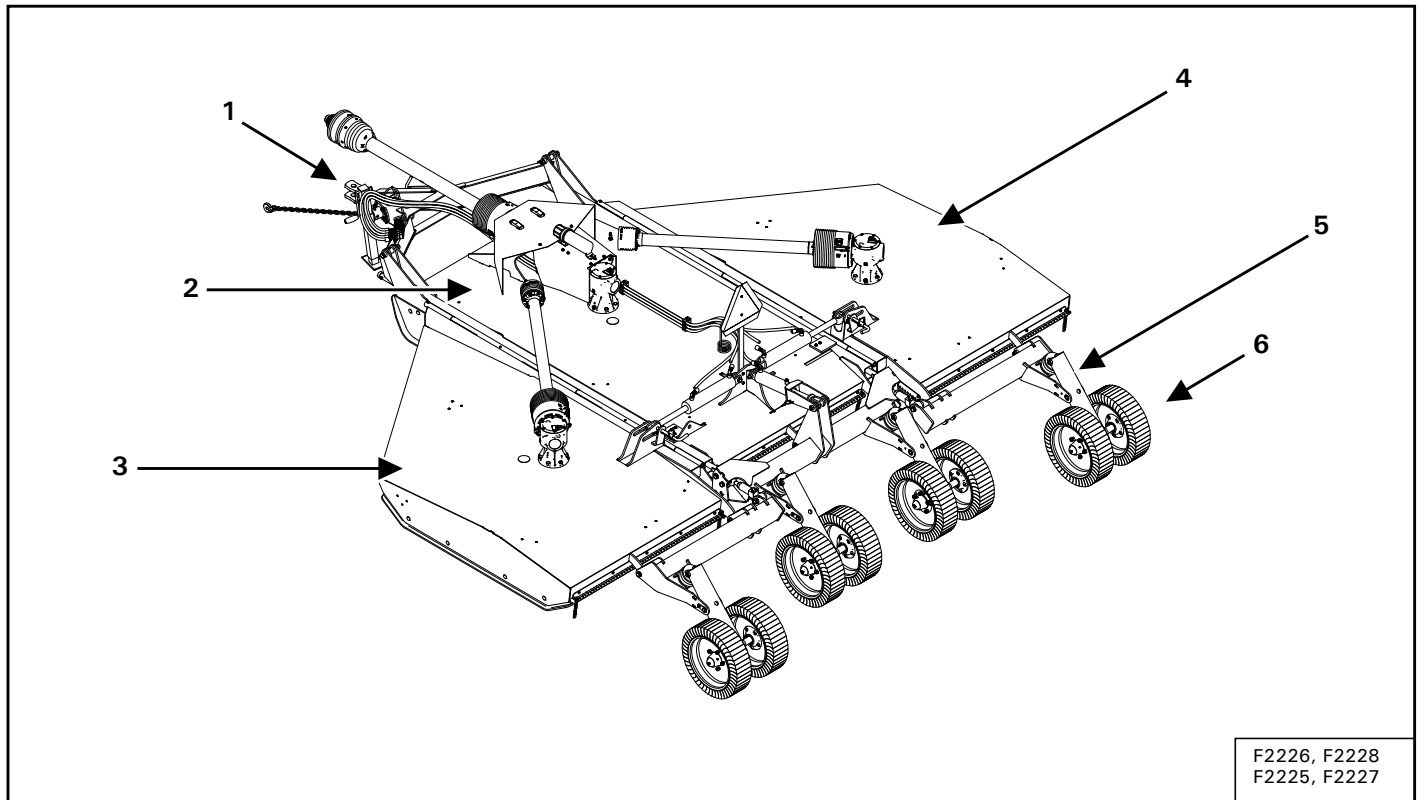

ITEM	PART NUMBER		DESCRIPTION
	540 PTO	1000 PTO	
1	F2358		HITCH ASSEMBLY
2	F2352	F2353	CENTER DECK ASSEMBLY
3	F2356	F2357	LH WING DECK ASSEMBLY
4	F2354	F2355	RH WING DECK ASSEMBLY
5	923942		LH SINGLE SPINDLE ASSEMBLY
	923943		RH SINGLE SPINDLE ASSEMBLY
	916205		DOUBLE SPINDLE ASSEMBLY
	923829		LH WALKING AXLE ASSEMBLY
	923880		RH WALKING AXLE ASSEMBLY
6	F1989		LAMINATED WHEEL ASSEMBLY
	F1990		AIRCRAFT WHEEL ASSEMBLY

Hitch Assembly

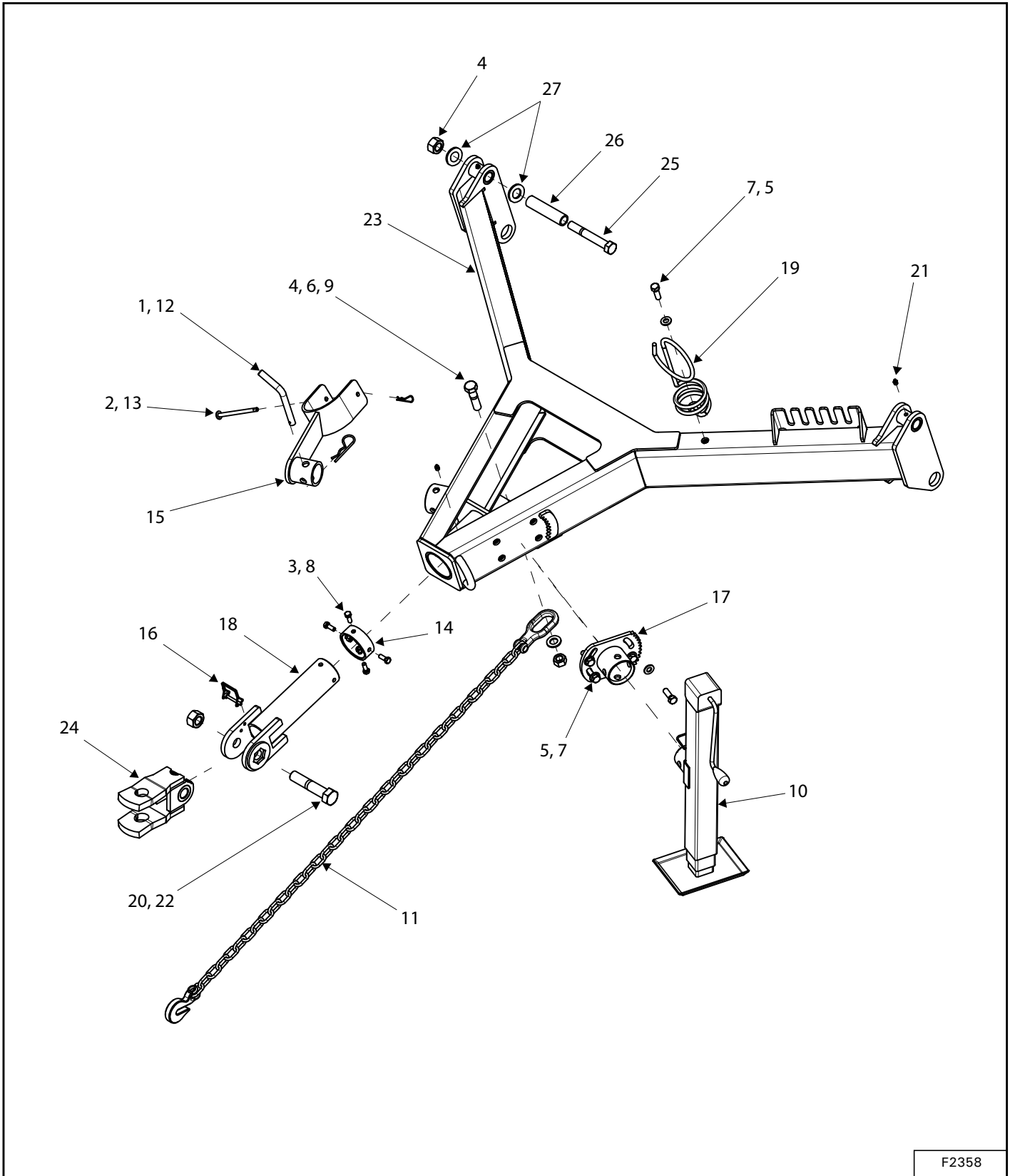

F2358

ITEM	PART NUMBER	DESCRIPTION	QTY
1	12779	#9 HAIR PIN CLIP (PL)	1
2	12780	#7 HAIR PIN CLIP	1
3	812363	3/8" LOCK NUT (PL)	4
4	812365	3/4" LOCK NUT (PL)	3
5	84048	1/2" SAE FLAT WASHER (PL)	5
6	84050	3/4" S.A.E. FLAT WASHER (PL)	1
7	84277	1/2" X 1 1/2" HEX BOLT (PL)	5
8	86170	3/8" X 1" HEX BOLT GR.5 (PL)	4
9	88742	3/4" X 3" HEX BOLT GR.5 (PL)	1
10	909195	JACK	1
11	910287	HOOK & SAFETY CHAIN ASSEMBLY	1
12	910288	LOCKING PIN	1
13	913029	WELDMENT-CLEVIS PIN	1
14	915703	TUBE-HITCH PRECISION STOP	1
15	916168	WELDT-PTO HOLDER	1
16	916976	SNAPPER CLIP	1
17	917112	WELDT-JACK STAND MOUNT	1
18	919144	WELDT-HITCH PRECISION	1
19	966314	HYDRAULIC HOSE HOLDER	1
20	967148	1" LOCK NUT (PL)	1
21	967164	DRIVE-IN GREASE ZERK	3
22	967527	1" X 5" HEX BOLT (PL)	1
23	F1991	WELDT-HITCH ROTARY CUTTER	1
24	F2017	ASSY-CAT 2 CLEVIS HITCH	1
25	84215	BOLT, 3/4" x 6" HEX GR 5 (PL)	2
26	916252	BUSHING, 1.00" OD x 0.76" ID x 5.13"	2
27	84522	FLAT WASHER, 1" ID SAE (PL)	4

Center Deck Assembly - 1030

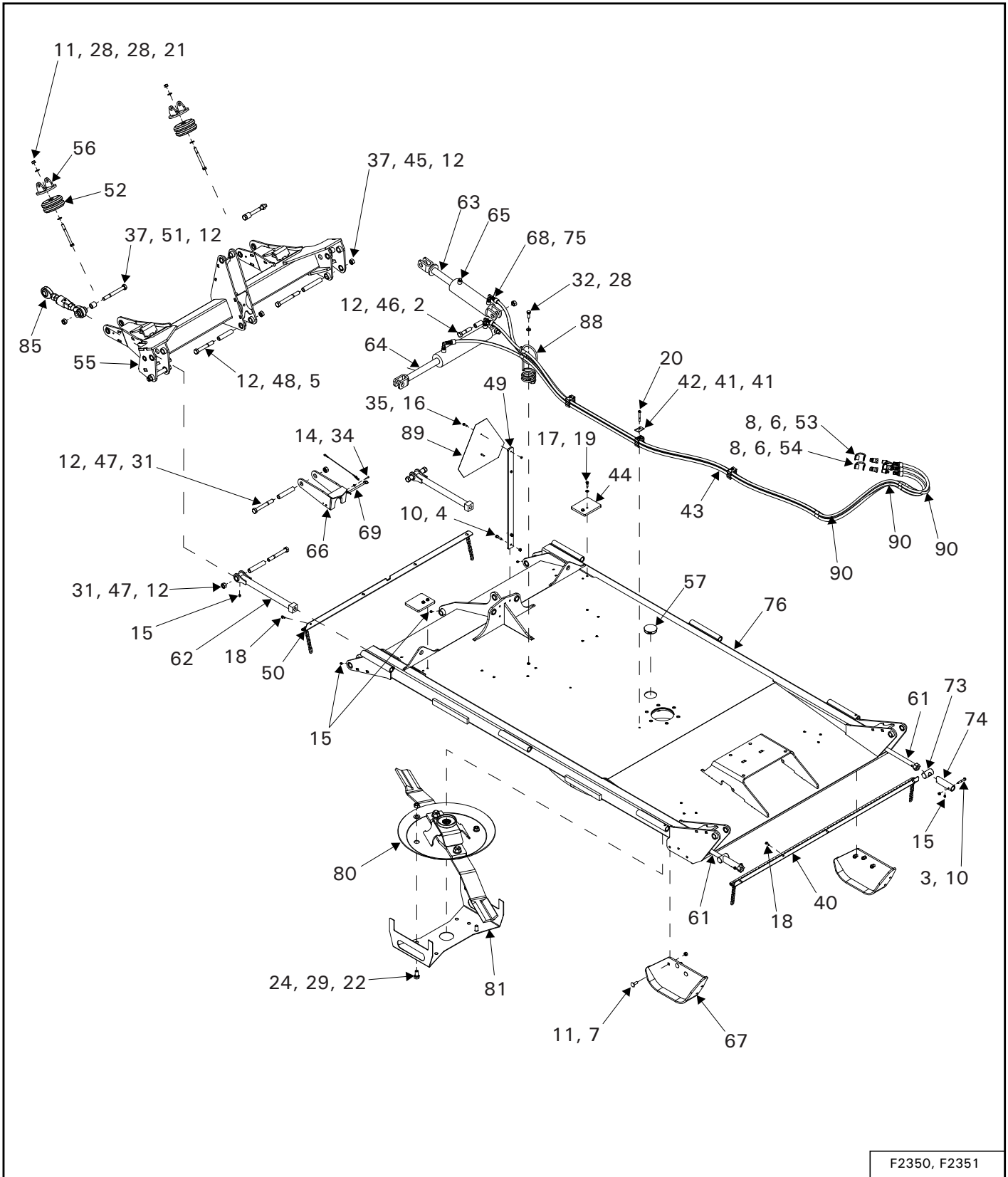

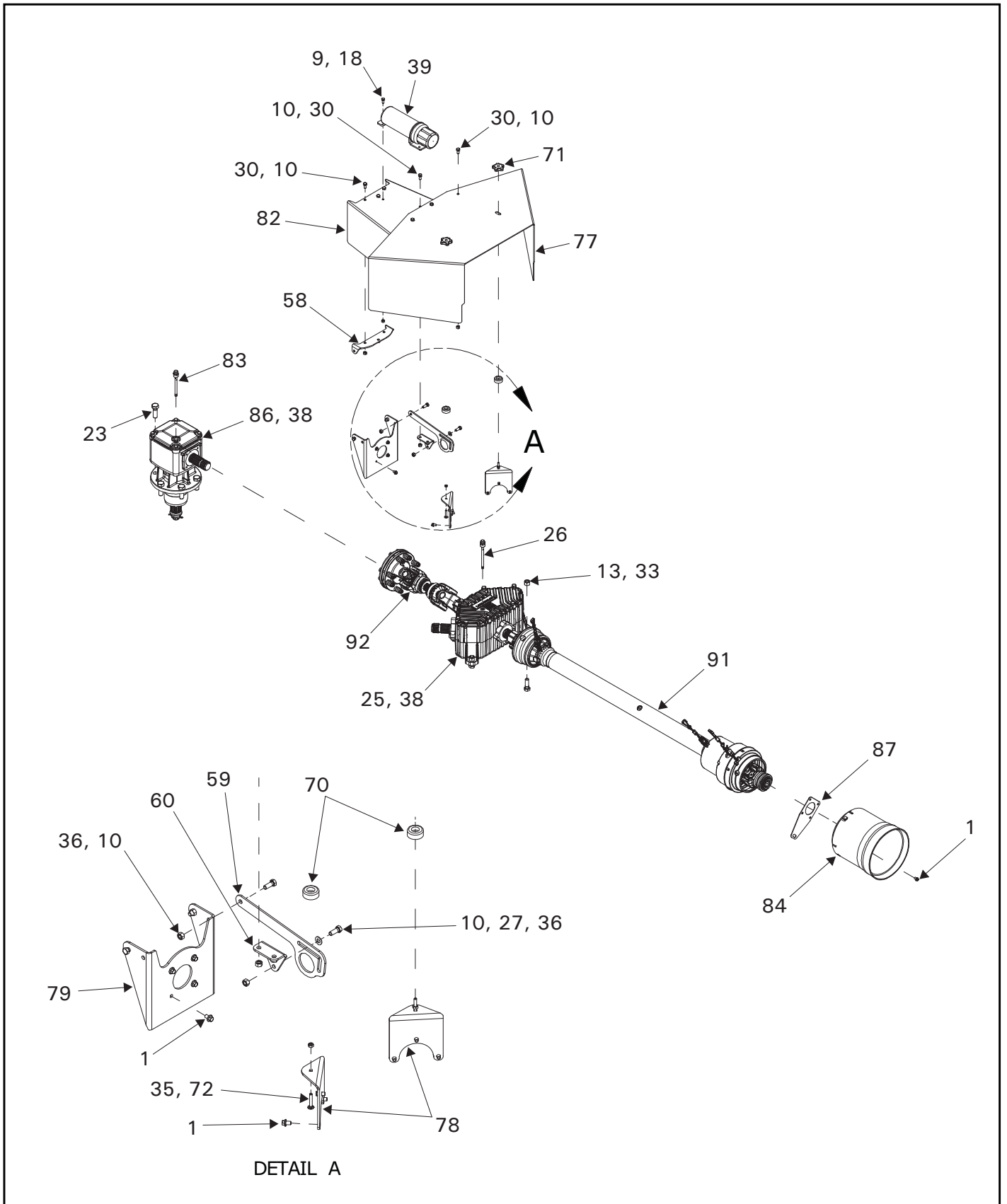

ITEM	PART NUMBER	DESCRIPTION	QTY
1	00051026	BOLT FL 8.8 P M8 X 12	13
2	810149	3/4" X 3 1/2" HEX BOLT (PL)	2
3	810958	3/8" X 2 1/4" HEX BOLT (PL)	2
4	811792	3/8" X 1 1/2" HEX BOLT GR.5 (PL)	2
5	812114	3/4" X 5 1/2" HEX BOLT (PL)	1
6	812208	NIPPLE 1/2" BODY 1/2"-14 NPTF QUICK CONNECT	3
7	812217	1/2" X 1 1/2" CARR BOLT (PL)	6
8	812320	ADAPTER-8 MPT X -6 MJIC	3
9	812362	5/16" LOCK NUT (PL)	2
10	812363	3/8" LOCK NUT (PL)	16
11	812364	1/2" LOCK NUT (PL)	8
12	812365	3/4" LOCK NUT (PL)	10
13	812482	5/8" LOCK NUT (PL)	4
14	813579	SCREW MACH 10-24X1.00 RDHD	1
15	967164	DRIVE-IN GREASE ZERK	7
16	81527	1/4" X 1" HEX BOLT (PL)	2
17	81546	5/16" FLAT WASHER (PL)	4
18	81549	5/16" X 3/4" HEX BOLT (PL)	11
19	81552	5/16" X 1 1/4" HEX BOLT (PL)	4
20	81558	5/16" X 2 3/4" HEX BOLT GR5 (PL)	3
21	81634	1/2" X 5 1/2" HEX BOLT (PL)	2
22	81681	3/4" X 1 1/2" HEX BOLT (PL)	2
23	81684	3/4" X 2 1/4" HEX BOLT (PL)	6
24	81700	3/4" HEX NUT (PL)	2
25	818272	GEARBOX - 540 RPM SPLITTER, RATIO 1:1.2	1
	818273	GEARBOX - 1000 RPM SPLITTER, RATIO 1.2:1	1
26	818369	VENT PLUG-1/2" GAS OIL FILLER LEVEL	1
27	84039	WASHER - 3/8" SAE FLAT (PL)	1
28	84048	1/2" SAE FLAT WASHER (PL)	5
29	84050	3/4" S.A.E. FLAT WASHER (PL)	2
30	84072	3/8" X 3/4" HEX BOLT (PL)	8
31	84215	3/4" X 6" HEX BOLT GR.5 (PL)	3
32	84277	1/2" X 1 1/2" HEX BOLT (PL)	1
33	84299	5/8" X 2" HEX BOLT GR.5 (PL)	4
34	84493	NUT LOCK (NYLON) 10-24 GRB PL	1
35	84498	1/4" LOCK NUT (PL)	4
36	86170	3/8" X 1" HEX BOLT GR.5 (PL)	4
37	902615	HEX BOLT-3/4 X 7" (PL)	4
38	908725	SAE 80W-90 GEAR OIL	5.8L
39	909277	MANUAL HOLDER 3 1/2" X 12"	1
40	915763	ASSY-CHAIN GUARD MIDDLE	1
41	915817	CLAMP-TWIN 0.63	6
42	915821	COVER-TWIN CLAMP	3

ITEM	PART NUMBER	DESCRIPTION	QTY
43	916032	HYD HOSE 236" 3/8 FJIC X 3/8 FJIC	3
44	916075	BUMPER-0.50 THK	2
45	916191	BUSHING-1.00OD, 0.76ID X 6.13	2
46	916210	BUSHING-1.00OD, 0.76ID X 2.19	2
47	916252	BUSHING-1.00OD, 0.76ID X 5.13	3
48	916276	BUSHING-1.00OD, 0.76ID X 4.56	1
49	916280L	PLATE-SLOW MOVING VEHICLE SIGN	1
50	916282	ASSY-CHAIN GUARD MIDDLE	1
51	916289	BUSHING-1.25OD, 0.764ID X 1.31	2
52	917244	RUBBER SPRING	2
53	917999	DUST CAP-1/2" GREEN	2
54	918000	DUST CAP-1/2" YELLOW	1
55	918146	WELDT-CENTER AXLE	1
56	918171	WELDT-RUBBER SPRING MOUNT	2
57	918201	HOLE PLUG-3.00 DIA X 0.250 THICK	1
58	919151	BRKT-GUARD PIVOT	1
59	919152L	PLATE-GUARD LATCH	1
60	919153	BRKT-GUARD LATCH	1
61	919175	WELDT-ROD LINKAGE	2
62	919176	WELDT-AXLE LINKAGE	2
63	919182	CYLINDER-3.0" DIA, 18.19 to 25.00	1
64	919183	CYLINDER-3.0" DIA, 23.00 TO 34.50	1
65	919185	PLUG-6 MORB VENT	1
66	919209	WELDT-CYLINDER LOCK	1
67	919285	WELDT-SKID SHOE MIDDLE	2
68	919398	ELBOW-6 FJIC X - 6 MJIC, 90°	3
69	920957	ASSY-0.38" DIA PIN W/LANYARD	1
70	920985	BUMPER-1.50" DIA W/WASHER	2
71	920986	KNOB-2.25" DIA THROUGH HOLE	2
72	920988	BOLT FULL CARR 0.250NC X 1.50 GR5PL	2
73	921078	ROD-TRUNNION	2
74	921081	TUBE-ROD ADJ.	2
75	921099	ADAPTER-6MORB X -6MJIC R.047	3
76	924226	WELDT-DECK MIDDLE	1
77	924233	GUARD-FRONT	1
78	924253	BRKT-GUARD LATCH MOUNT	2
79	924259	BRKT-GUARD PIVOT	1
80	924288	ASSY-CW PAN AND BLADE	1
81	924458	BRKT-BLADE PAN LOCK	1
82	924974	GUARD-REAR	1
83	925178	VENT PLUG-1/2" GAS OIL FILLER LEVEL	1

ITEM	PART NUMBER	DESCRIPTION	QTY
84	925182	GUARD-SAFETY CONE W/FLANGE	1
85	925960	ASSY-TURNBUCKLE	1
86	926031	GEARBOX-RATIO 1:1.83	1
	924585	GEARBOX-RATIO 1:1	
87	926517L	PLATE-SAFETY LATCH HOOK	1
88	966314	HYDRAULIC HOSE HOLDER	1
89	967066	SLOW MOVING VEHICLE SIGN	1
90	967103	TIE 30"	3
91	F2083	PTO SHAFT-ROTARY CUTTER 540 RPM	1
	F2084	PTO SHAFT-ROTARY CUTTER 1000 RPM	1
92	F2085	PTO SHAFT-SLIP CLUTCH CENTER	1

Farm King



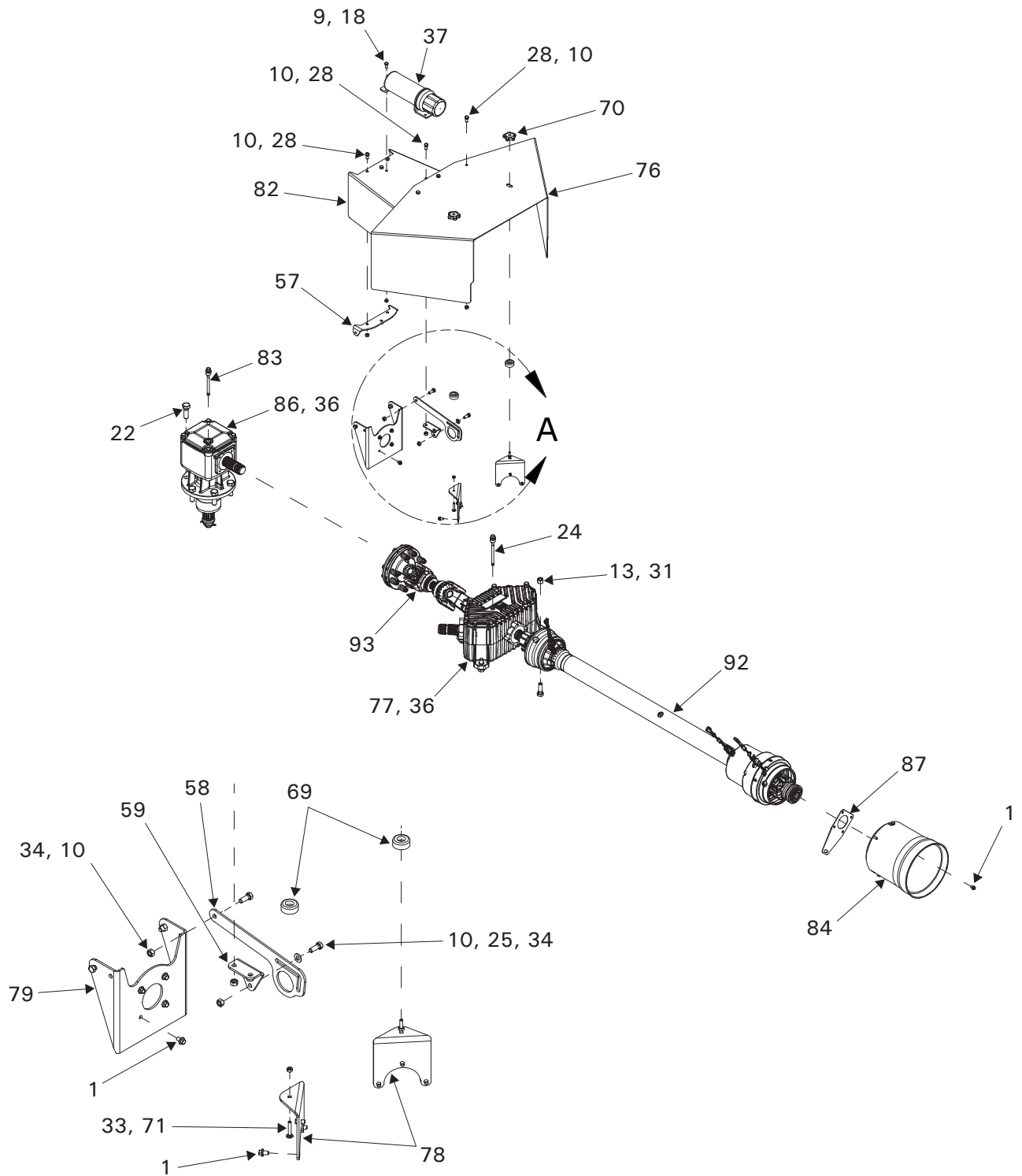

DETAIL A

F2352, F2353

ITEM	PART NUMBER	DESCRIPTION	QTY
1	00051026	BOLT FL 8.8 P M8 X 12	13
2	810149	3/4" X 3 1/2" HEX BOLT (PL)	3
3	810958	3/8" X 2 1/4" HEX BOLT (PL)	2
4	811792	3/8" X 1 1/2" HEX BOLT GR.5 (PL)	2
5	812114	3/4" X 5 1/2" HEX BOLT (PL)	1
6	812208	NIPPLE 1/2" BODY 1/2"-14 NPTF QUICK CONNECT	5
7	812217	1/2" X 1 1/2" CARR BOLT (PL)	6
8	812320	ADAPTER-8 MPT X -6 MJIC	5
9	812362	5/16" LOCK NUT (PL)	2
10	812363	3/8" LOCK NUT (PL)	16
11	812364	1/2" LOCK NUT (PL)	8
12	812365	3/4" LOCK NUT (PL)	11
13	812482	5/8" LOCK NUT (PL)	4
14	813579	SCREW MACH 10-24X1.00 RDHD	1
15	967197	5/16" X 4" HEX BOLT (PL)	3
16	81527	1/4" X 1" HEX BOLT (PL)	2
17	81546	5/16" FLAT WASHER (PL)	4
18	81549	5/16" X 3/4" HEX BOLT (PL)	11
19	81552	5/16" X 1 1/4" HEX BOLT (PL)	4
20	81634	1/2" X 5 1/2" HEX BOLT (PL)	2
21	81681	3/4" X 1 1/2" HEX BOLT (PL)	2
22	81684	3/4" X 2 1/4" HEX BOLT (PL)	6
23	81700	3/4" HEX NUT (PL)	2
24	818369	VENT PLUG-1/2" GAS OIL FILLER LEVEL	1
25	84039	WASHER - 3/8" SAE FLAT (PL)	1
26	84048	1/2" SAE FLAT WASHER (PL)	5
27	84050	3/4" S.A.E. FLAT WASHER (PL)	2
28	84072	3/8" X 3/4" HEX BOLT (PL)	8
29	84215	3/4" X 6" HEX BOLT GR.5 (PL)	3
30	84277	1/2" X 1 1/2" HEX BOLT (PL)	1
31	84299	5/8" X 2" HEX BOLT GR.5 (PL)	4
32	84493	NUT LOCK (NYLON) 10-24 GRB PL	1
33	84498	1/4" LOCK NUT (PL)	4
34	86170	3/8" X 1" HEX BOLT GR.5 (PL)	4
35	902615	HEX BOLT-3/4 X 7" (PL)	4
36	908725	SAE 80W-90 GEAR OIL	5.8L
37	909277	MANUAL HOLDER 3 1/2" X 12"	1
38	915763	ASSY-CHAIN GUARD MIDDLE	1
39	915817	CLAMP-TWIN 0.63	9
40	915821	COVER-TWIN CLAMP	3
41	916032	HYD HOSE 236" 3/8 FJIC X 3/8 FJIC	3
42	916075	BUMPER-0.50 THK	2
43	916191	BUSHING-1.000D, 0.76ID X 6.13	2

ITEM	PART NUMBER	DESCRIPTION	QTY
44	916210	BUSHING-1.00OD, 0.76ID X 2.19	3
45	916252	BUSHING-1.00OD, 0.76ID X 5.13	3
46	916276	BUSHING-1.00OD, 0.76ID X 4.56	1
47	916280L	PLATE-SLOW MOVING VEHICLE SIGN	1
48	916282	ASSY-CHAIN GUARD MIDDLE	1
49	916289	BUSHING-1.25OD, 0.764ID X 1.31	2
50	917244	RUBBER SPRING	2
51	917998	DUST CAP-1/2" BLUE	2
52	917999	DUST CAP-1/2" GREEN	2
53	918000	DUST CAP-1/2" YELLOW	1
54	918146	WELDT-CENTER AXLE	1
55	918171	WELDT-RUBBER SPRING MOUNT	2
56	918201	HOLE PLUG-3.00 DIA X 0.250 THICK	1
57	919151	BRKT-GUARD PIVOT	1
58	919152L	PLATE-GUARD LATCH	1
59	919153	BRKT-GUARD LATCH	1
60	919175	WELDT-ROD LINKAGE	2
61	919176	WELDT-AXLE LINKAGE	2
62	919182	CYLINDER-3.0" DIA, 18.19 to 25.00	1
63	919183	CYLINDER-3.0" DIA, 23.00 TO 34.50	2
64	919185	PLUG-6 MORB VENT	1
65	919209	WELDT-CYLINDER LOCK	1
66	919285	WELDT-SKID SHOE MIDDLE	2
67	919398	ELBOW-6 FJIC X - 6 MJIC, 90°	5
68	920957	ASSY-0.38" DIA PIN W/LANYARD	1
69	920985	BUMPER-1.50" DIA W/WASHER	2
70	920986	KNOB-2.25" DIA THROUGH HOLE	2
71	920988	BOLT FULL CARR 0.250NC X 1.50 GR5PL	2
72	921078	ROD-TRUNNION	2
73	921081	TUBE-ROD ADJ.	2
74	921099	ADAPTER-6MORB X -6MJIC R.047	5
75	924226	WELDT-DECK MIDDLE	1
76	924233	GUARD-FRONT	1
77	924251	GEARBOX-SPLITTER, RATIO 1:1.2 - 540 RPM	1
	924586	GEARBOX-SPLITTER, RATIO 1.2:1 - 1000 RPM	1
78	924253	BRKT-GUARD LATCH MOUNT	2
79	924259	BRKT-GUARD PIVOT	1
80	924288	ASSY-CW PAN AND BLADE	1
81	924458	BRKT-BLADE PAN LOCK	1
82	924974	GUARD-REAR	1
83	925178	VENT PLUG-1/2" GAS OIL FILLER LEVEL	1

ITEM	PART NUMBER	DESCRIPTION	QTY
84	925182	GUARD-SAFETY CONE W/FLANGE	1
85	925960	ASSY-TURNBUCKLE	2
86	926031	GEARBOX-RATIO 1:1.83 - 540 RPM	1
	924585	GEARBOX-RATIO 1:1 - 1000 RPM	1
87	926517L	PLATE-SAFETY LATCH HOOK	1
88	966314	HYDRAULIC HOSE HOLDER	1
89	967066	SLOW MOVING VEHICLE SIGN	1
90	967103	TIE 30"	3
91	967164	DRIVE-IN GREASE ZERK	7
92	F2083	PTO SHAFT-ROTARY CUTTER 540 RPM	1
	F2084	PTO SHAFT-ROTARY CUTTER 1000 RPM	1
93	F2085	PTO SHAFT-SLIP CLUTCH CENTER	1

Farm King



Deck Hinge Assembly

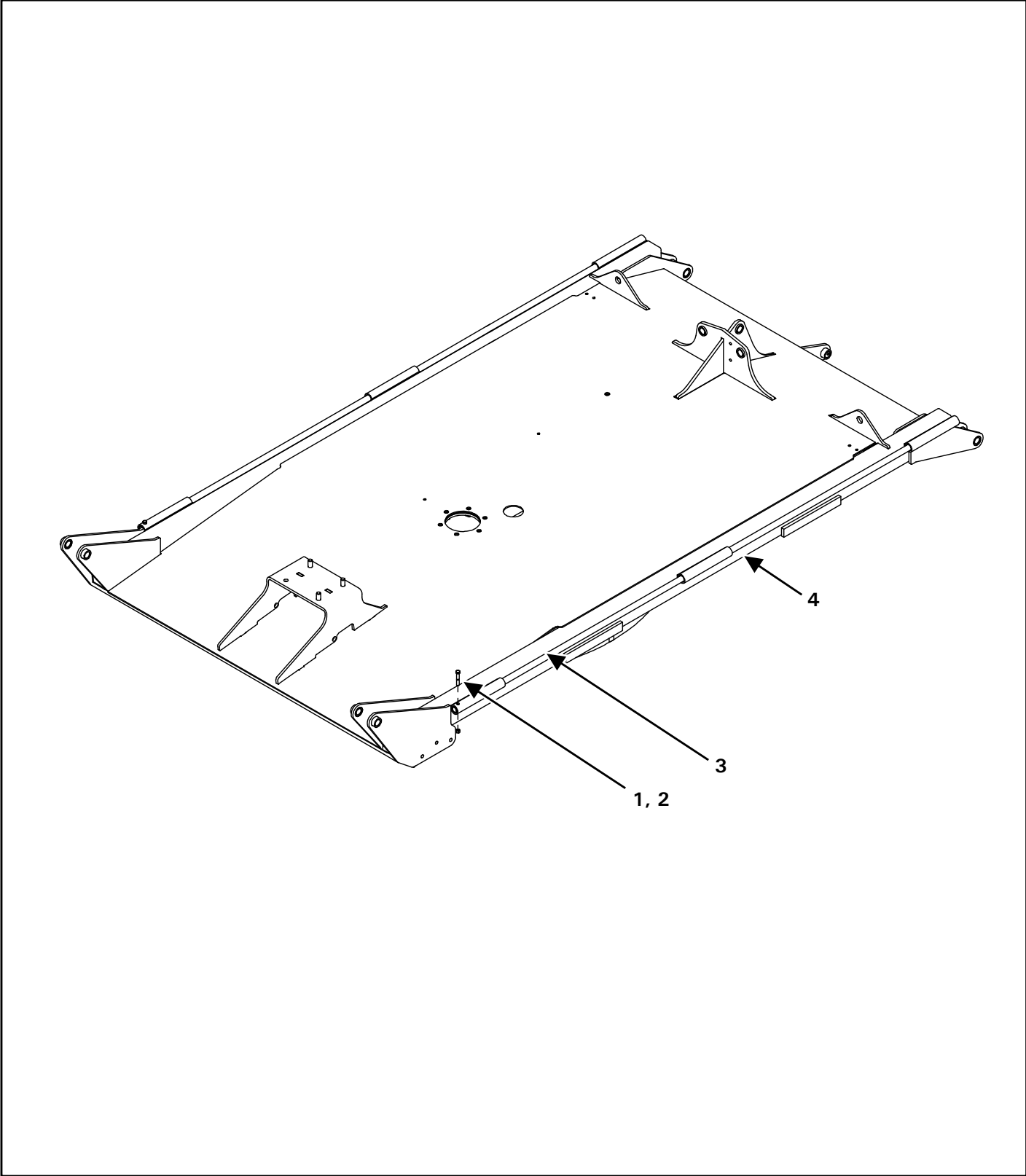

ITEM	PART NUMBER	DESCRIPTION	QTY
1	810958	BOLT, 3/8" x 2-1/4" HEX (PL)	2
2	812363	LOCK NUT, 3/8" (PL)	2
3	915784	DECK ROD HINGE	2
4	924226	WELDMENT - MIDDLE DECK	1

ITEM	PART NUMBER	DESCRIPTION	QTY
1	00051026	BOLT FL 8.8 P M8 X 12	3
2	811751	3/4" X 5" HEX BOLT (PL)	2
3	812217	1/2" X 1 1/2" CARR BOLT (PL)	4
4	812364	1/2" LOCK NUT (PL)	5
5	812365	3/4" LOCK NUT (PL)	2
6	81549	5/16" X 3/4" HEX BOLT (PL)	13
7	81634	1/2" X 5 1/2" HEX BOLT (PL)	1
8	81684	3/4" X 2 1/4" HEX BOLT (PL)	6
9	84048	1/2" SAE FLAT WASHER (PL)	2
10	908725	SAE 80W-90 GEAR OIL	2.6L
11	915542	ASSY-CHAIN HOLDER WING FRONT	1
12	915543	ASSY-CHAIN HOLDER WING REAR	1
13	916188	BUSHING-1.00OD, 0.76ID X 4.13	2
14	916310	ASSY-CHAIN HOLDER WING REAR	1
15	916975	ROD-LOCKING HANDLE	1
16	916976	SNAPPER CLIP	1
17	917244	RUBBER SPRING	1
18	918171	WELDT-RUBBER SPRING MOUNT	1
19	918195	WELDT-LH WING AXLE	1
20	918201	HOLE PLUG-3.00 DIA X 0.250 THICK	1
21	919166	WELDT-SKID SHOE WING	1
22	924229	WELDT-DECK LH	1
23	924256	GEARBOX-RATIO 1:1.5 - 540 RPM	1
	924583	GEARBOX-RATIO 1:1.22 - 1000 RPM	1
24	924288	ASSY-CW PAN AND BLADE	1
25	925178	VENT PLUG-1/2" GAS OIL FILLER LEVEL	1
26	925182	GUARD-SAFETY CONE W/FLANGE	1
27	926517L	PLATE-SAFETY LATCH HOOK	1
28	967164	DRIVE-IN GREASE ZERK	4
29	9812425	1/4" X 1 1/4" SPRING PIN (PL)	1
30	F2086	PTO SHAFT-SPLITTER TO WINGS	1

RH Wing Deck Assembly

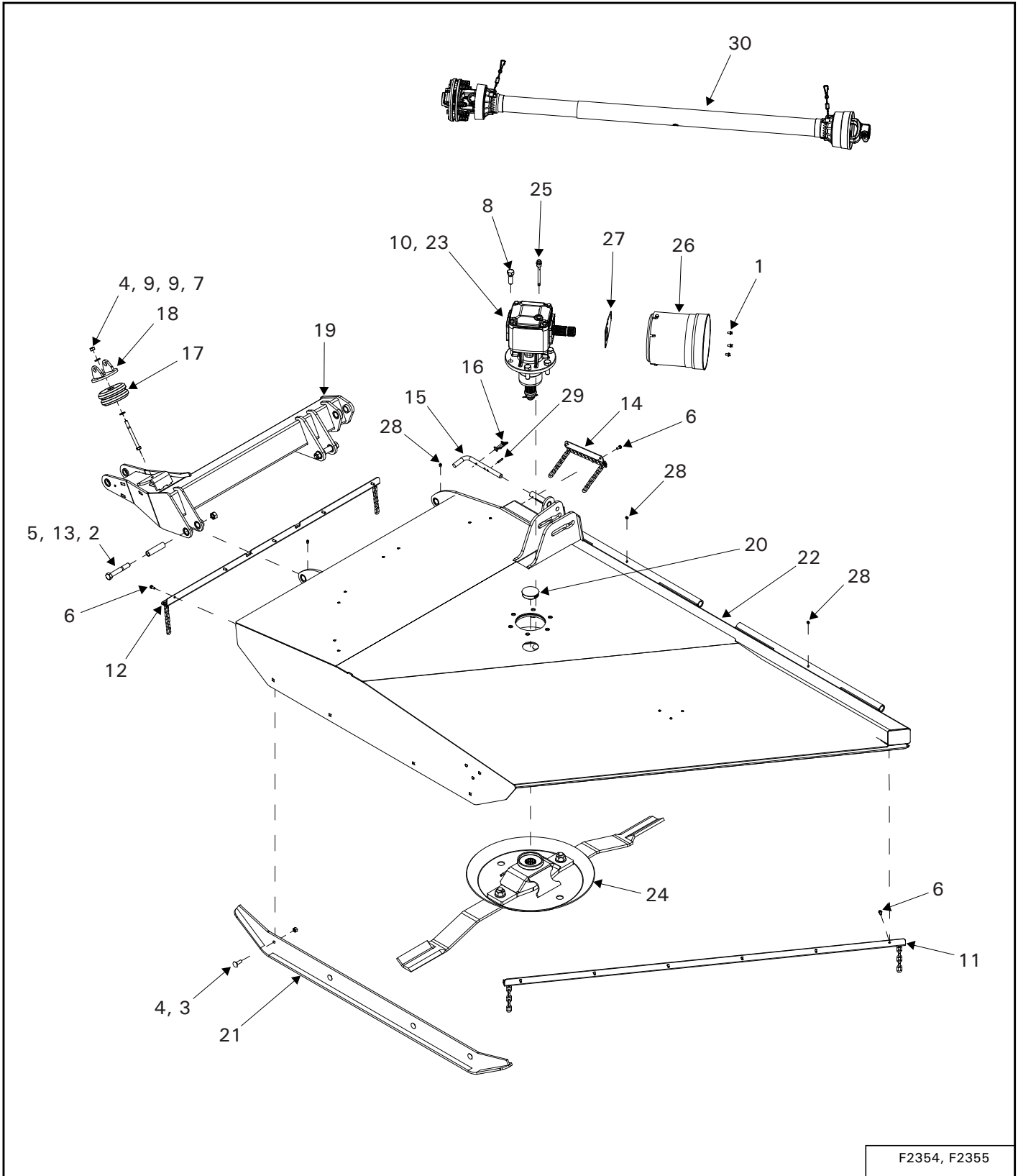

F2354, F2355

ITEM	PART NUMBER	DESCRIPTION	QTY
1	00051026	BOLT FL 8.8 P M8 X 12	3
2	811751	3/4" X 5" HEX BOLT (PL)	2
3	812217	1/2" X 1 1/2" CARR BOLT (PL)	4
4	812364	1/2" LOCK NUT (PL)	5
5	812365	3/4" LOCK NUT (PL)	2
6	81549	5/16" X 3/4" HEX BOLT (PL)	13
7	81634	1/2" X 5 1/2" HEX BOLT (PL)	1
8	81684	3/4" X 2 1/4" HEX BOLT (PL)	6
9	84048	1/2" SAE FLAT WASHER (PL)	2
10	908725	SAE 80W-90 GEAR OIL	2.6L
11	915542	ASSY-CHAIN HOLDER WING FRONT	1
12	915543	ASSY-CHAIN HOLDER WING REAR	1
13	916188	BUSHING-1.000D, 0.76ID X 4.13	2
14	916310	ASSY-CHAIN HOLDER WING REAR	1
15	916975	ROD-LOCKING HANDLE	1
16	916976	SNAPPER CLIP	1
17	917244	RUBBER SPRING	1
18	918171	WELDT-RUBBER SPRING MOUNT	1
19	918196	WELDT-RH WING AXLE	1
20	918201	HOLE PLUG-3.00 DIA X 0.250 THICK	1
21	919166	WELDT-SKID SHOE WING	1
22	924221	WELDT-DECK RH	1
23	924257	GEARBOX-RATIO 1:1.5 - 540 RPM	1
	924584	GEARBOX-RATIO 1:1.22 - 1000 RPM	1
24	924289	ASSY-CCW PAN AND BLADE	1
25	925178	VENT PLUG-1/2" GAS OIL FILLER LEVEL	1
26	925182	GUARD-SAFETY CONE W/FLANGE	1
27	926517L	PLATE-SAFETY LATCH HOOK	1
28	967164	DRIVE-IN GREASE ZERK	4
29	9812425	1/4" X 1 1/4" SPRING PIN (PL)	1
30	F2086	PTO SHAFT-SPLITTER TO WINGS	1

Chain Kit Assembly

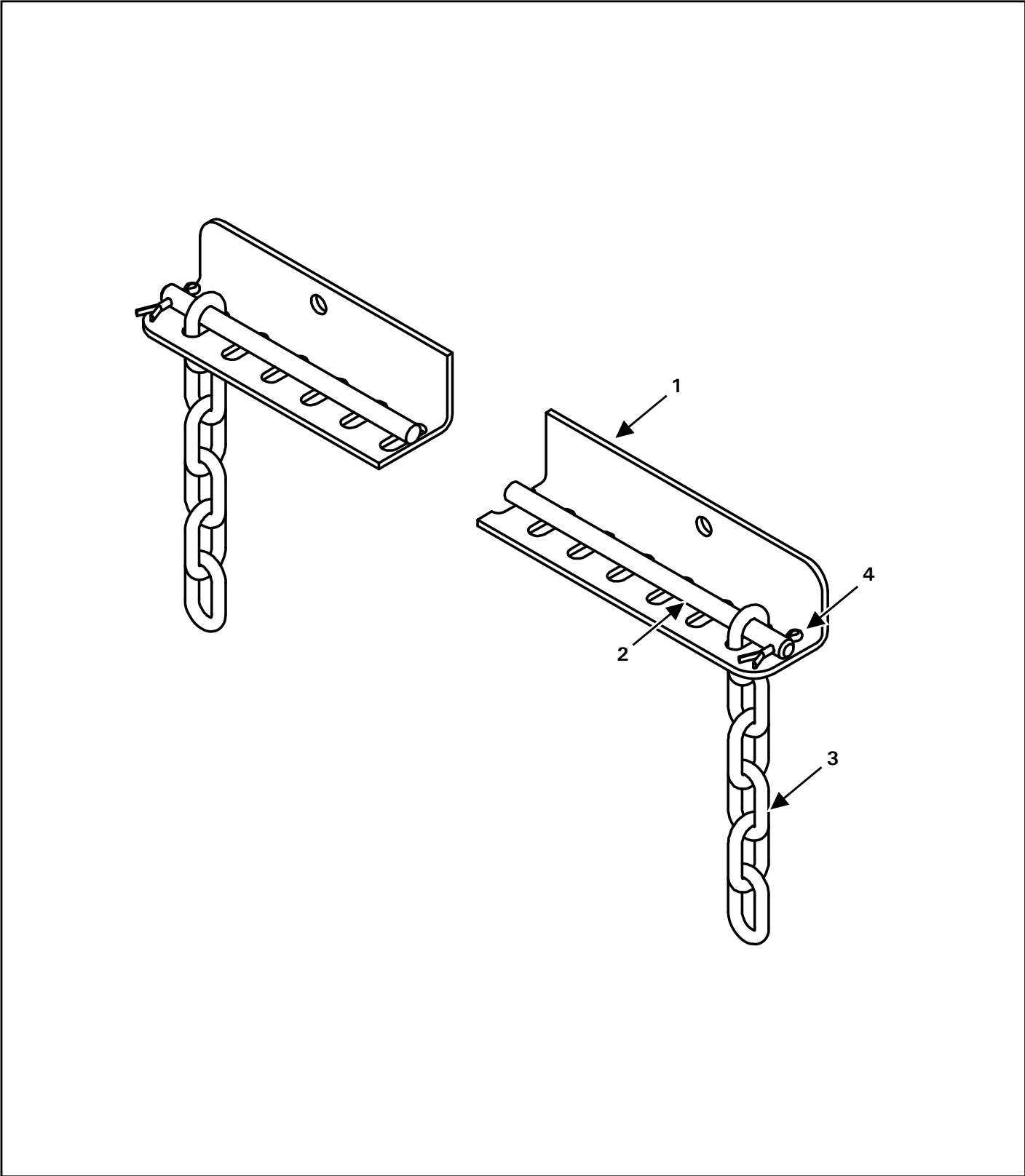

Front Wing Chain Holder Assembly (# 915542)

ITEM	PART NUMBER	DESCRIPTION	QTY
1	915782	FRONT WING CHAIN HOLDER	1
2	916002	FRONT WING CHAIN HOLDER ROD	1
3	966591	CHAIN 1/4" (6 LINK)	75
4	9812430	COTTER PIN, 1/8" x 1" (PL)	2

Rear Wing Chain Holder Assembly (# 915543)

ITEM	PART NUMBER	DESCRIPTION	QTY
1	915540	REAR WING CHAIN HOLDER	1
2	915550	REAR WING CHAIN HOLDER ROD	1
3	966591	CHAIN 1/4" (6 LINK)	56
4	9812430	COTTER PIN, 1/8" x 1" (PL)	2

Rear Wing Short Chain Holder Assembly (# 916310)

ITEM	PART NUMBER	DESCRIPTION	QTY
1	919291	CHAIN HOLDER-WING REAR	1
2	916181	ROD-CHAIN HOLDER WING REAR	1
3	966591	CHAIN .25" (6 LINK)	10
4	9812430	1/8" X 1" COTTER PIN (PL)	2

Front Middle Chain Guard Assembly (# 916282)

ITEM	PART NUMBER	DESCRIPTION	QTY
1	916283	FRONT CENTER DECK CHAIN HOLDER	1
2	916284	FRONT CENTER DECK CHAIN HOLDER ROD	1
3	966591	CHAIN 1/4" (6 LINK)	57
4	9812430	COTTER PIN, 1/8" x 1" (PL)	2

Rear Middle Chain Guard Assembly (# 915763)

ITEM	PART NUMBER	DESCRIPTION	QTY
1	915764	REAR CENTER DECK CHAIN HOLDER	1
2	915765	REAR CENTER DECK CHAIN HOLDER ROD	1
3	966591	CHAIN 1/4" (6 LINK)	63
4	9812430	COTTER PIN, 1/8" x 1" (PL)	2

Double Chain Kit Assembly

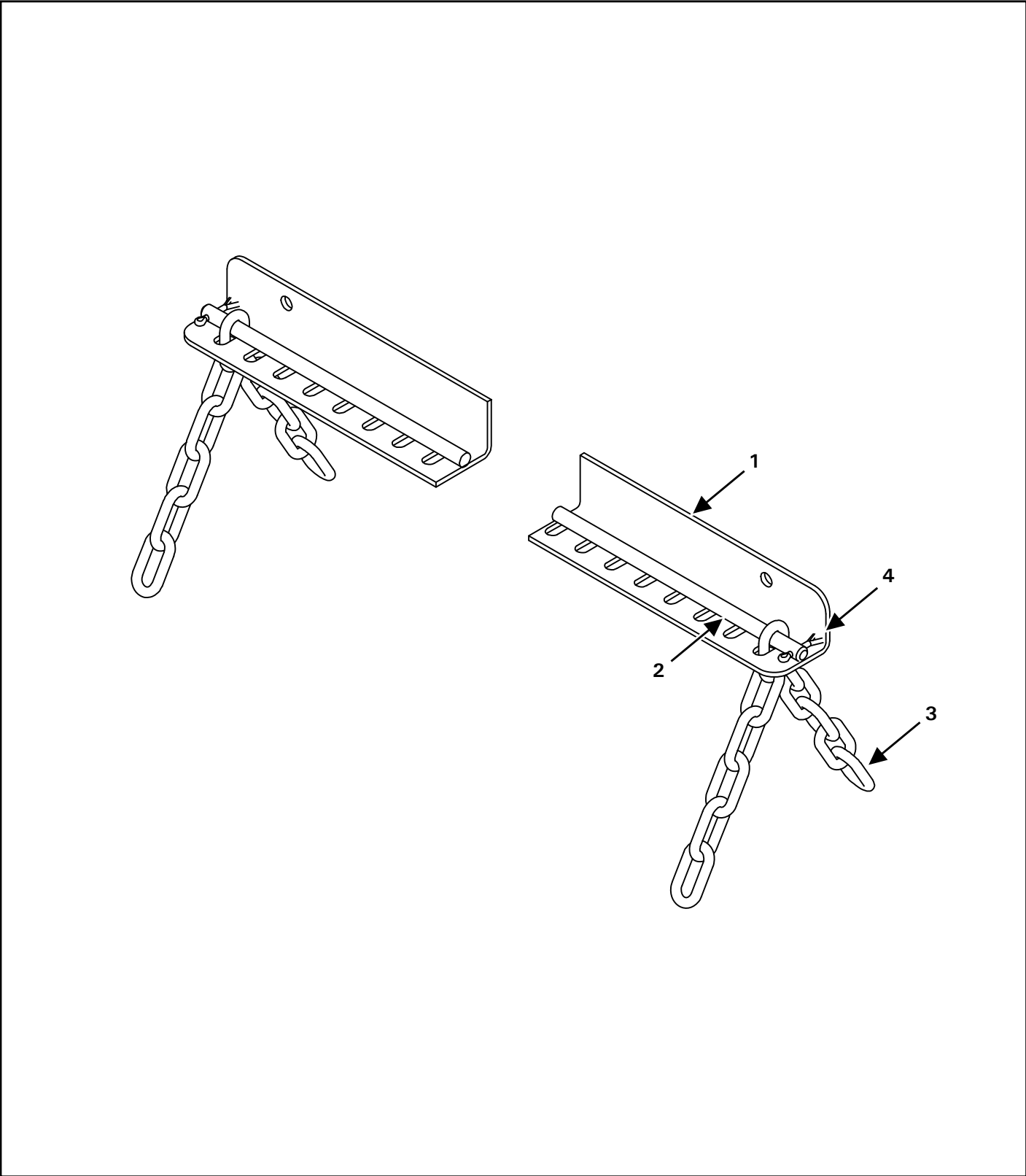

Front Middle Double Chain Holder Assembly (# 923912)

ITEM	PART NUMBER	DESCRIPTION	QTY
1	915764	CHAIN HOLDER-MIDDLE	1
2	915765	ROD-CHAIN HOLDER	1
3	923914	CHAIN-0.250" DIA, 11 LINK	63
4	9812430	1/8" X 1" COTTER PIN (PL)	2

Rear Middle Double Chain Holder Assembly (# 923913)

ITEM	PART NUMBER	DESCRIPTION	QTY
1	916283	CHAIN HOLDER-MIDDLE	1
2	916284	ROD-CHAIN HOLDER	1
3	923914	CHAIN-0.250" DIA, 11 LINK	57
4	9812430	1/8" X 1" COTTER PIN (PL)	2

Rear Wing Short Double Chain Holder Assembly (# 923938)

ITEM	PART NUMBER	DESCRIPTION	QTY
1	916181	ROD-CHAIN HOLDER WING REAR	1
2	919291	CHAIN HOLDER-WING REAR	1
3	923914	CHAIN-0.250" DIA, 11 LINK	10
4	9812430	1/8" X 1" COTTER PIN (PL)	2

Front Wing Double Chain Guard Assembly (# 923939)

ITEM	PART NUMBER	DESCRIPTION	QTY
1	915782	CHAIN HOLDER-WING FRONT	1
2	916002	ROD-CHAIN HOLDER WING FRONT	1
3	923914	CHAIN-0.250" DIA, 11 LINK	75
4	9812430	1/8" X 1" COTTER PIN (PL)	2

Rear Wing Double Chain Guard Assembly (# 923940)

ITEM	PART NUMBER	DESCRIPTION	QTY
1	915540	CHAIN HOLDER-WING REAR	1
2	915550	ROD-CHAIN HOLDER WING REAR	1
3	923914	CHAIN-0.250" DIA, 11 LINK	56
4	9812430	1/8" X 1" COTTER PIN (PL)	2

AXLE

Laminated Tire Assembly - 1030

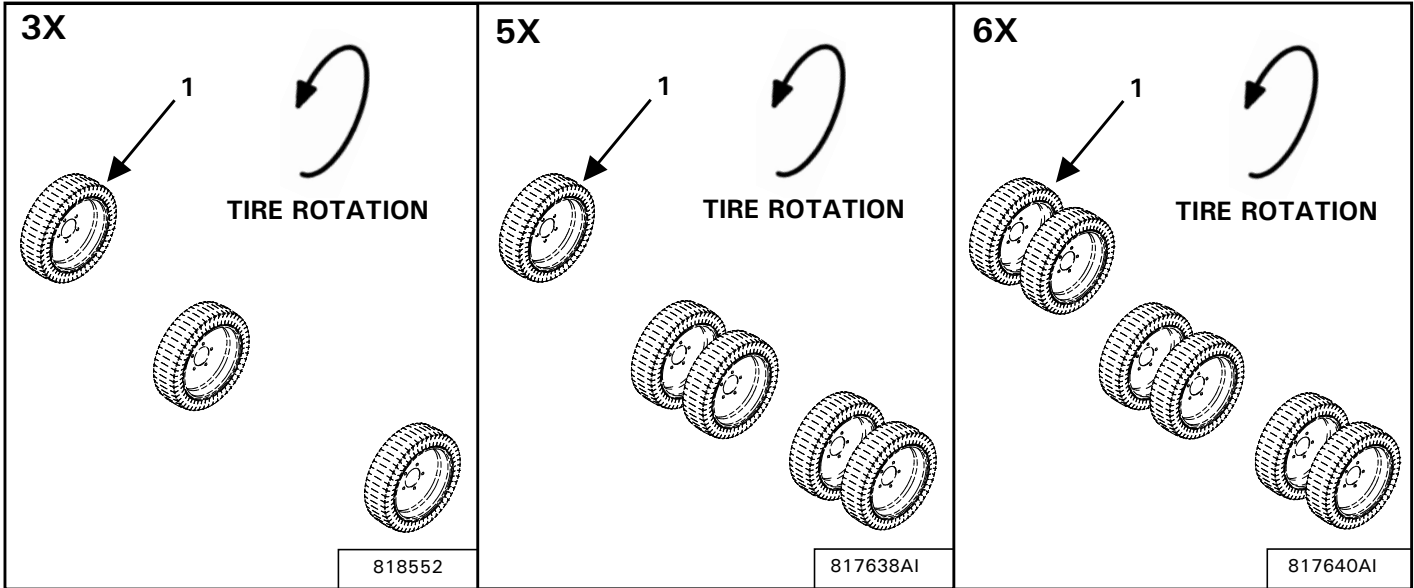

ITEM	PART NUMBER	DESCRIPTION	QTY
1	F1989	3X LAMINATED TIRE ASSEMBLY	3
		5X LAMINATED TIRE ASSEMBLY	5
		6X LAMINATED TIRE ASSEMBLY	6

Laminated Tire Assembly - 1530

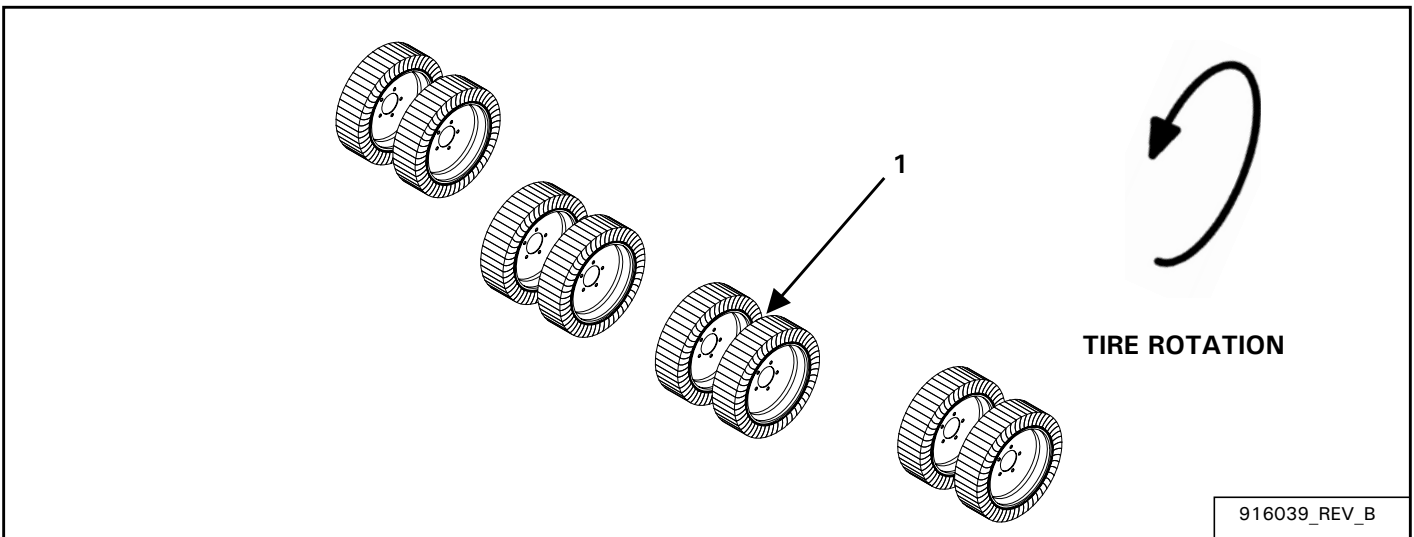

ITEM	PART NUMBER	DESCRIPTION	QTY
1	F1989	6 X LAMINATED TIRE ASSEMBLY	6
		8 X LAMINATED TIRE ASSEMBLY	8

Aircraft Tire Assembly - 1030

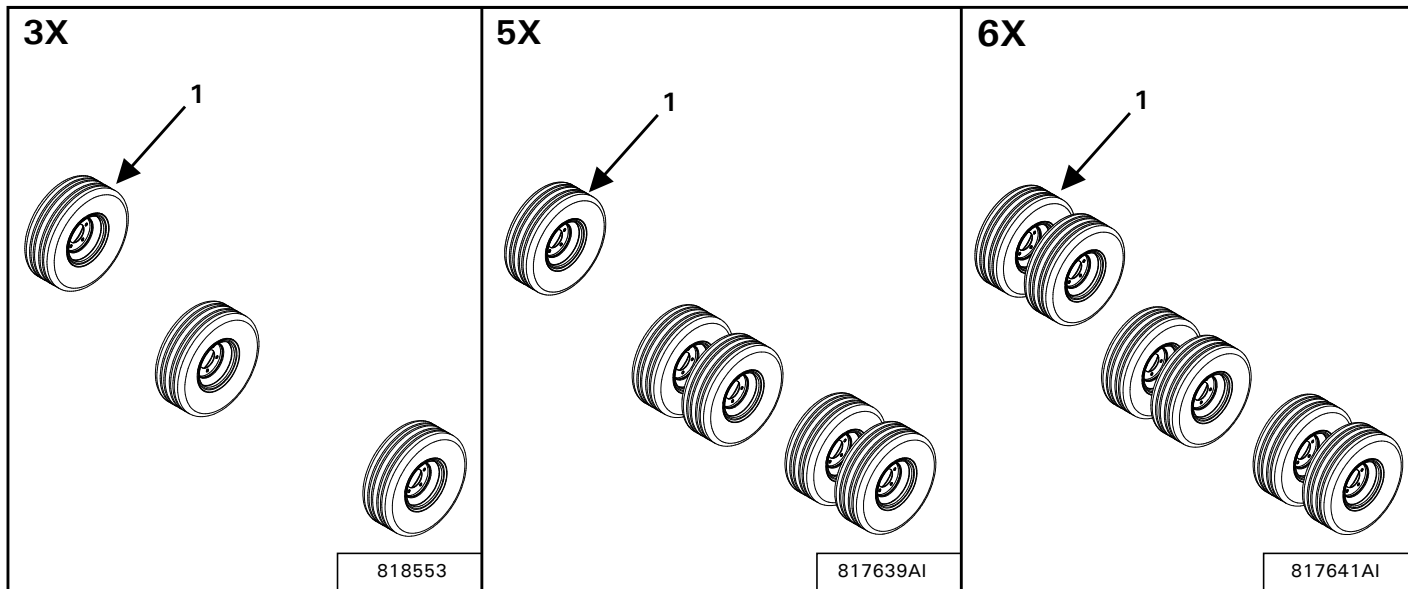

ITEM	PART NUMBER	DESCRIPTION	QTY
1	F1990	3X AIRCRAFT TIRE ASSEMBLY	3
		5X AIRCRAFT TIRE ASSEMBLY	5
		6X AIRCRAFT TIRE ASSEMBLY	6

Aircraft Tire Assembly - 1530

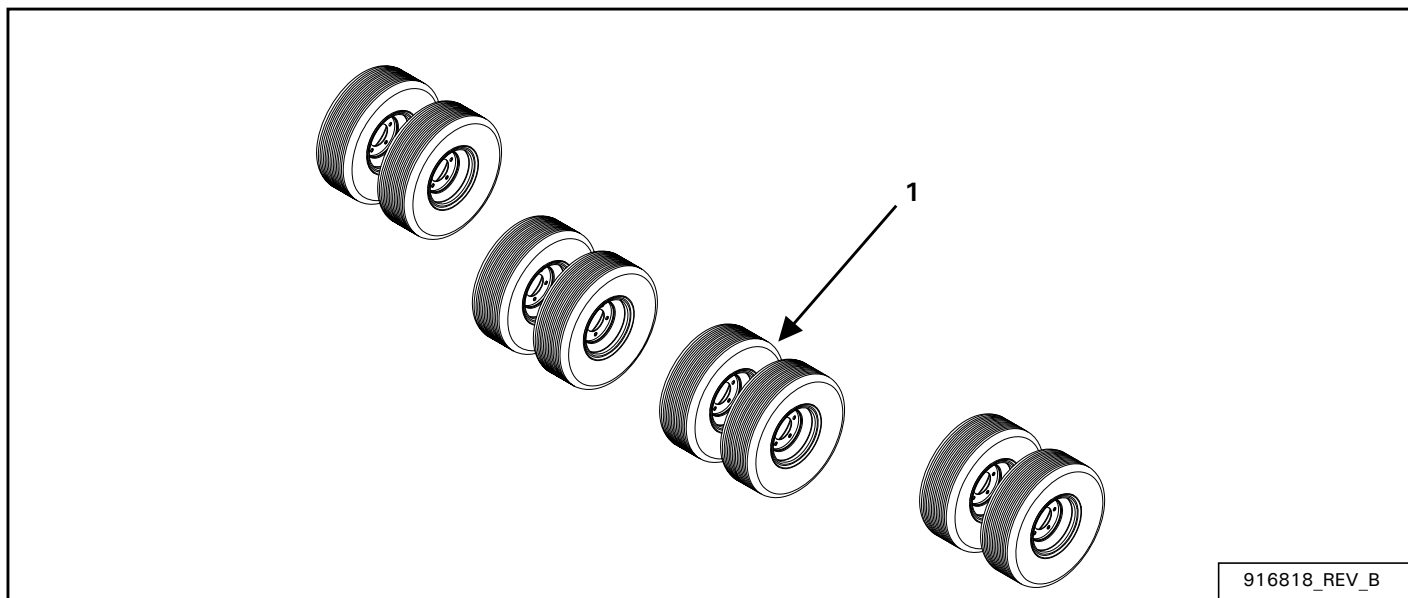

ITEM	PART NUMBER	DESCRIPTION	QTY
1	F1990	6 X AIRCRAFT TIRE ASSEMBLY	6
		8 X AIRCRAFT TIRE ASSEMBLY	8

LH Axle Assembly - 1530

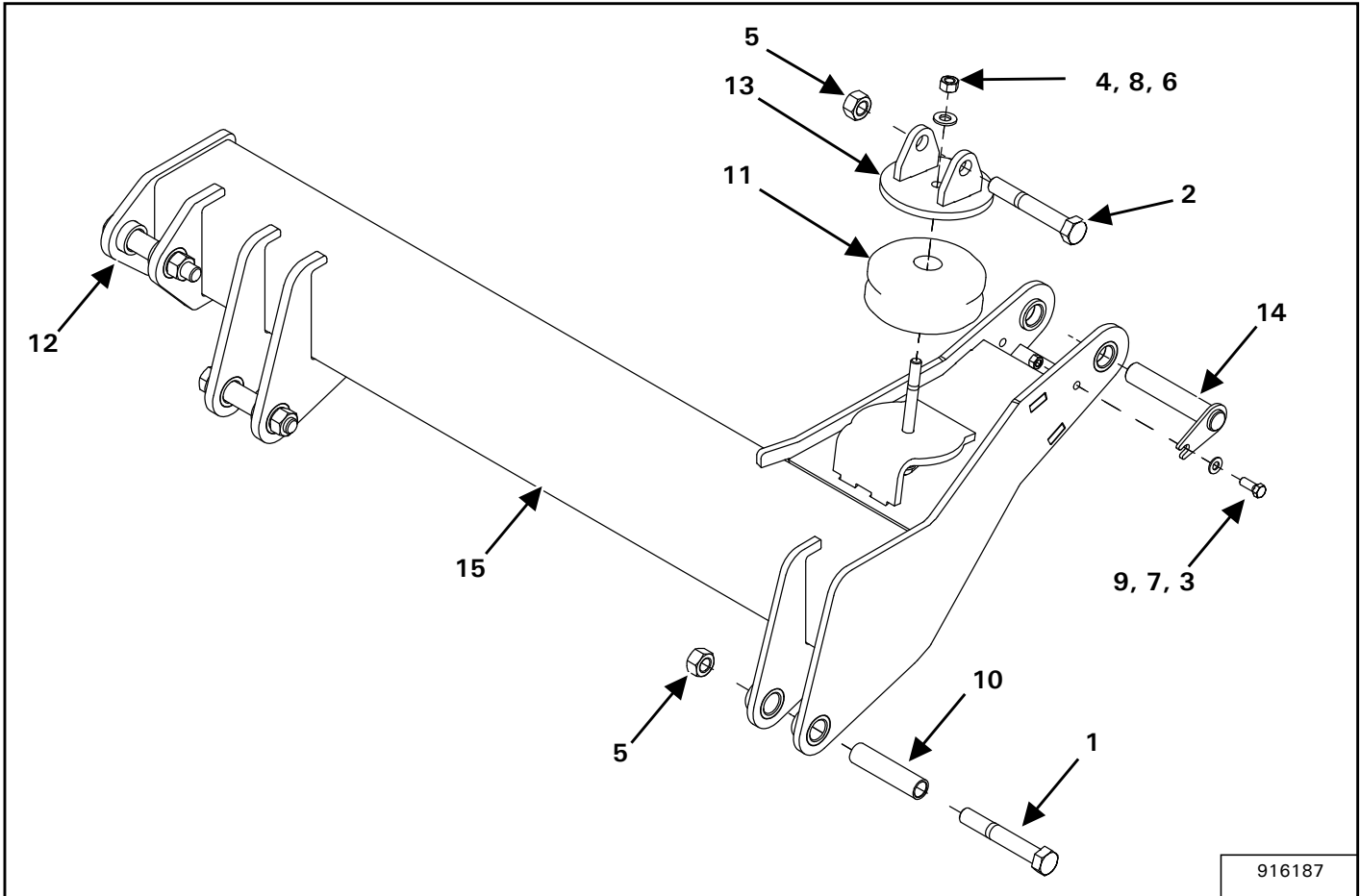

ITEM	PART NUMBER	DESCRIPTION	QTY
1	811751	3/4" X 5" HEX BOLT (PL)	3
2	812114	3/4" X 5 1/2" HEX BOLT (PL)	1
3	812363	3/8" LOCK NUT (PL)	1
4	812364	1/2" LOCK NUT (PL)	1
5	812365	3/4" LOCK NUT (PL)	4
6	81634	1/2" X 5 1/2" HEX BOLT (PL)	1
7	84039	3/8" FLAT WASHER (PL)	1
8	84048	1/2" SAE FLAT WASHER (PL)	2
9	86170	3/8" X 1" HEX BOLT GR.5 (PL)	1
10	916188	BUSHING-1.00OD, 0.76ID X 4.13	2
11	917244	RUBBER SPRING	1
12	917280	BUSHING-0.98OD, 0.76ID X 3.69	1
13	918171	WELDT-RUBBER SPRING MOUNT	1
14	918194	WELDT-AXLE PIN	1
15	918195	WELDT-LH WING AXLE	1

RH Axle Assembly

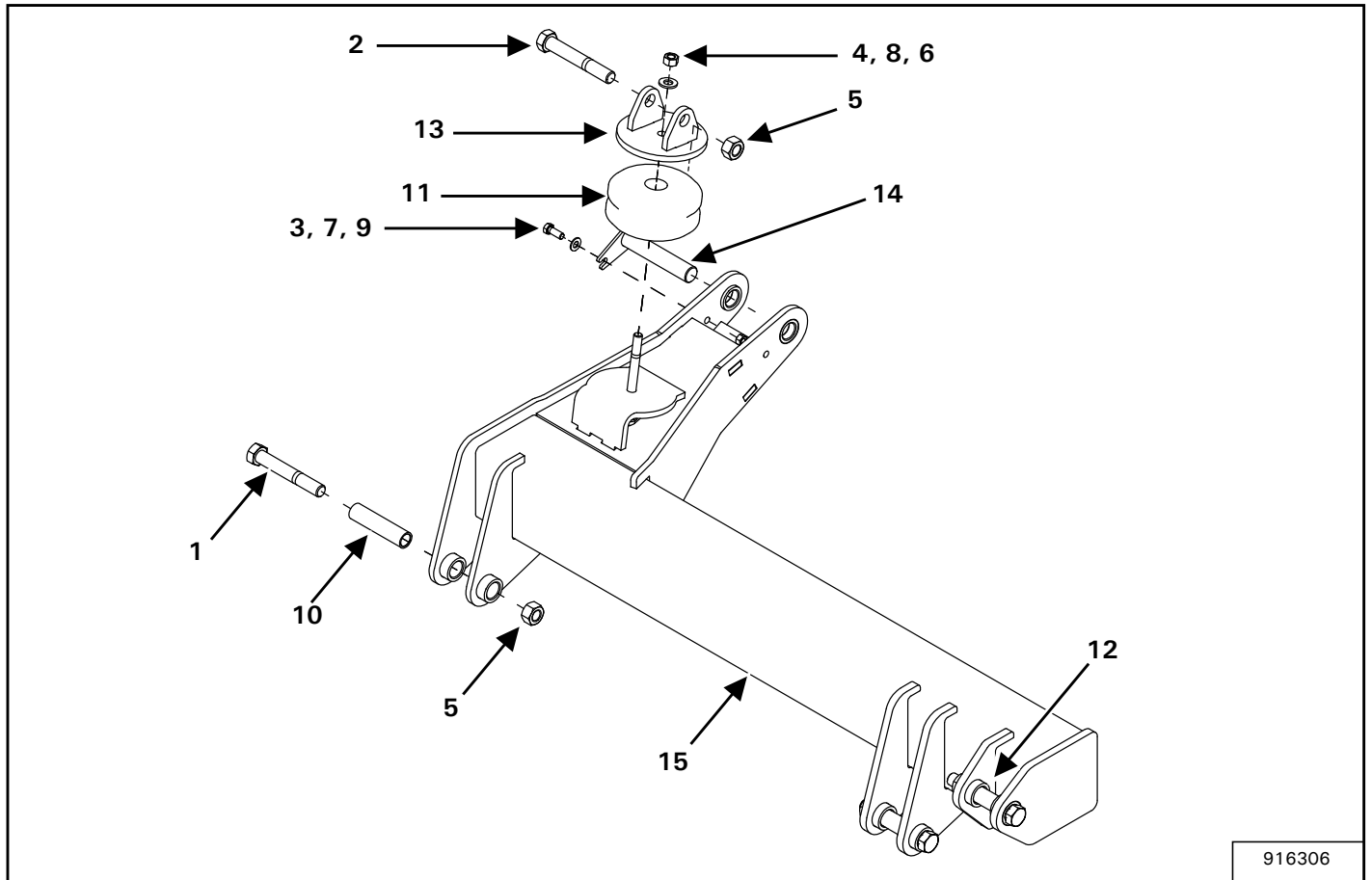

ITEM	PART NUMBER	DESCRIPTION	QTY
1	811751	3/4" X 5" HEX BOLT (PL)	3
2	812114	3/4" X 5 1/2" HEX BOLT (PL)	1
3	812363	3/8" LOCK NUT (PL)	1
4	812364	1/2" LOCK NUT (PL)	1
5	812365	3/4" LOCK NUT (PL)	4
6	81634	1/2" X 5 1/2" HEX BOLT (PL)	1
7	84039	3/8" FLAT WASHER (PL)	1
8	84048	1/2" SAE FLAT WASHER (PL)	2
9	86170	3/8" X 1" HEX BOLT GR.5 (PL)	1
10	916188	BUSHING-1.00OD, 0.76ID X 4.13	2
11	917244	RUBBER SPRING	1
12	917280	BUSHING-0.98OD, 0.76ID X 3.69	1
13	918171	WELDT-RUBBER SPRING MOUNT	1
14	918194	WELDT-AXLE PIN	1
15	918196	WELDT-RH WING AXLE	1

Center Axle Assembly

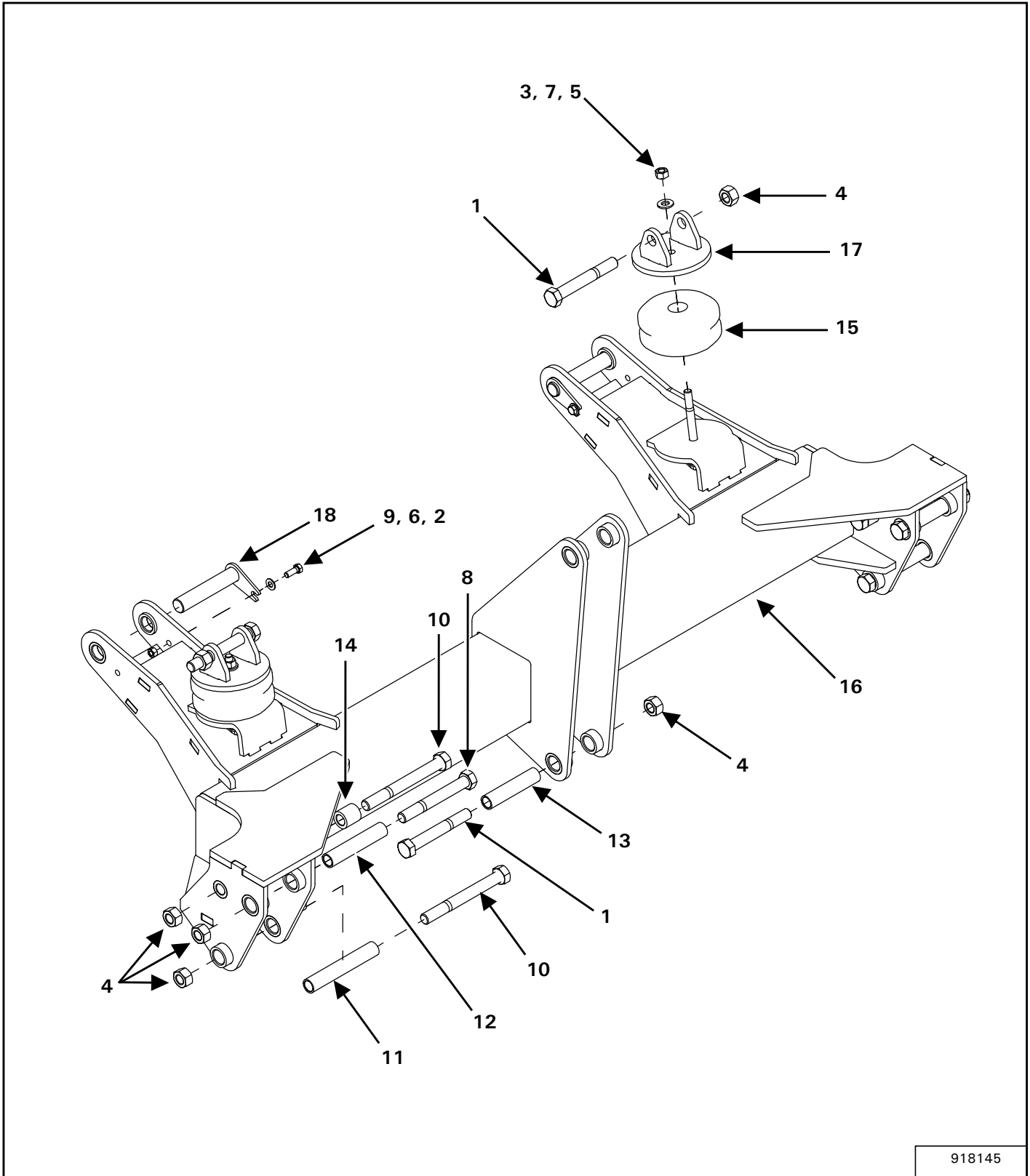

918145

ITEM	PART NUMBER	DESCRIPTION	QTY
1	812114	3/4" X 5 1/2" HEX BOLT (PL)	3
2	812363	3/8" LOCK NUT (PL)	2
3	812364	1/2" LOCK NUT (PL)	2
4	812365	3/4" LOCK NUT (PL)	9
5	81634	1/2" X 5 1/2" HEX BOLT (PL)	2
6	84039	3/8" FLAT WASHER (PL)	2
7	84048	1/2" SAE FLAT WASHER (PL)	4
8	84215	3/4" X 6" HEX BOLT GR.5 (PL)	2
9	86170	3/8" X 1" HEX BOLT GR.5 (PL)	2
10	902615	HEX BOLT-3/4 X 7" (PL)	4
11	916191	BUSHING-1.00OD, 0.76ID X 6.13	2
12	916252	BUSHING-1.00OD, 0.76ID X 5.13	2
13	916276	BUSHING-1.00OD, 0.76ID X 4.56	1
14	916289	BUSHING-1.25OD, 0.764ID X 1.31	2
15	917244	RUBBER SPRING	2
16	918146	WELDT-CENTER AXLE	1
17	918171	WELDT-RUBBER SPRING MOUNT	2
18	918194	WELDT-AXLE PIN	2

Double Spindle Assembly

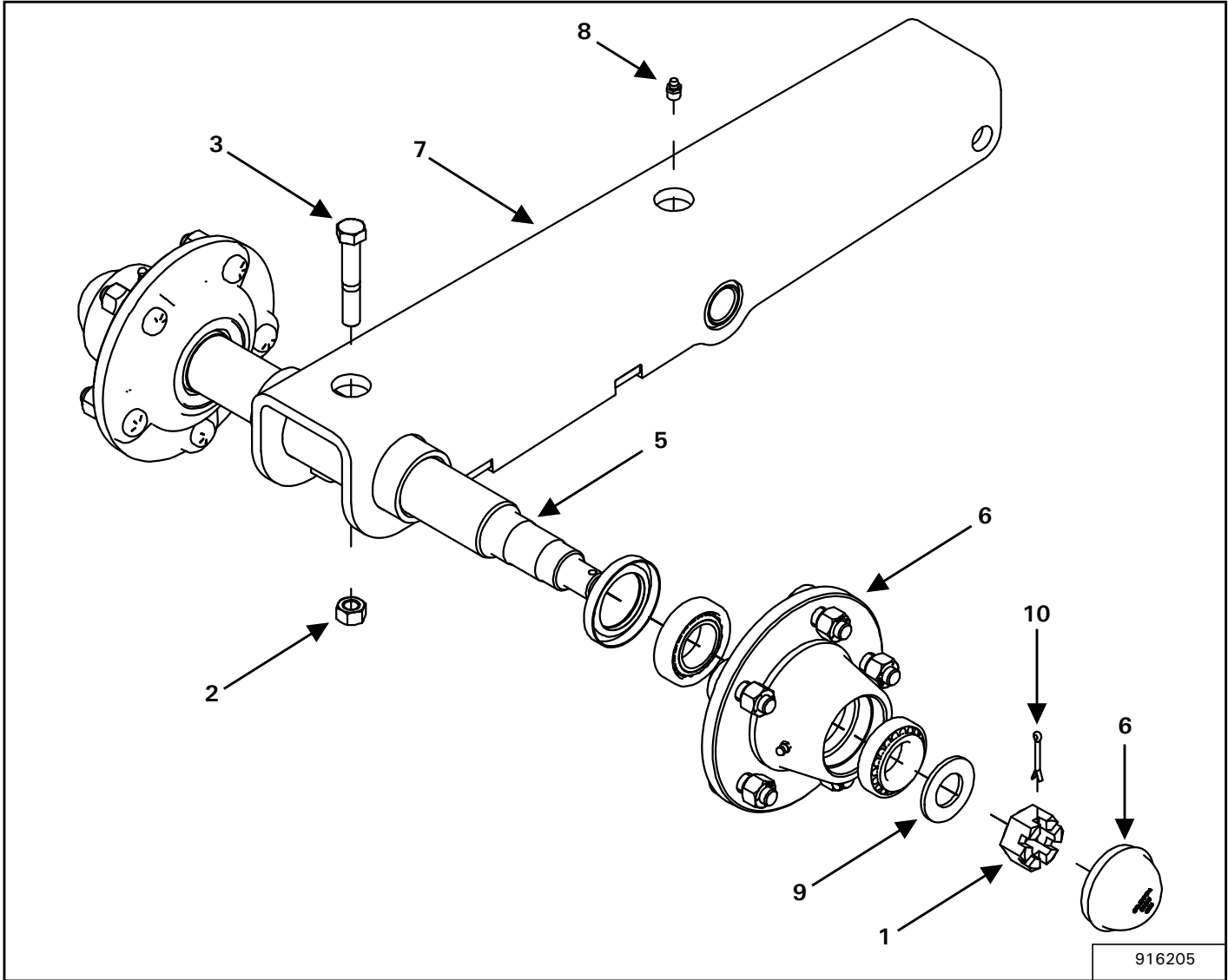

ITEM	PART NUMBER	DESCRIPTION	QTY
1	810010	SLOTTED NUT, 7/8" UNF (BR)	2
2	812364	LOCK NUT, 1/2" (PL)	1
3	81627	BOLT, 1/2" x 3" HEX (PL)	1
4	904902	GREASE GRADE 2 (Not Shown)	50 g
5	915669	REMOVABLE DOUBLE SPINDLE SHAFT	1
6	915679	HUB, HA517	2
7	918182	SUSPENSION ARM WELDMENT	1
8	967164	DRIVE-IN GREASE ZERK	1
9	967713	7/8" SAE FLAT WASHER (BR)	2
10	9812486	COTTER PIN, 1/8" x 1-1/2" (BR)	2

LH Single Spindle Assembly

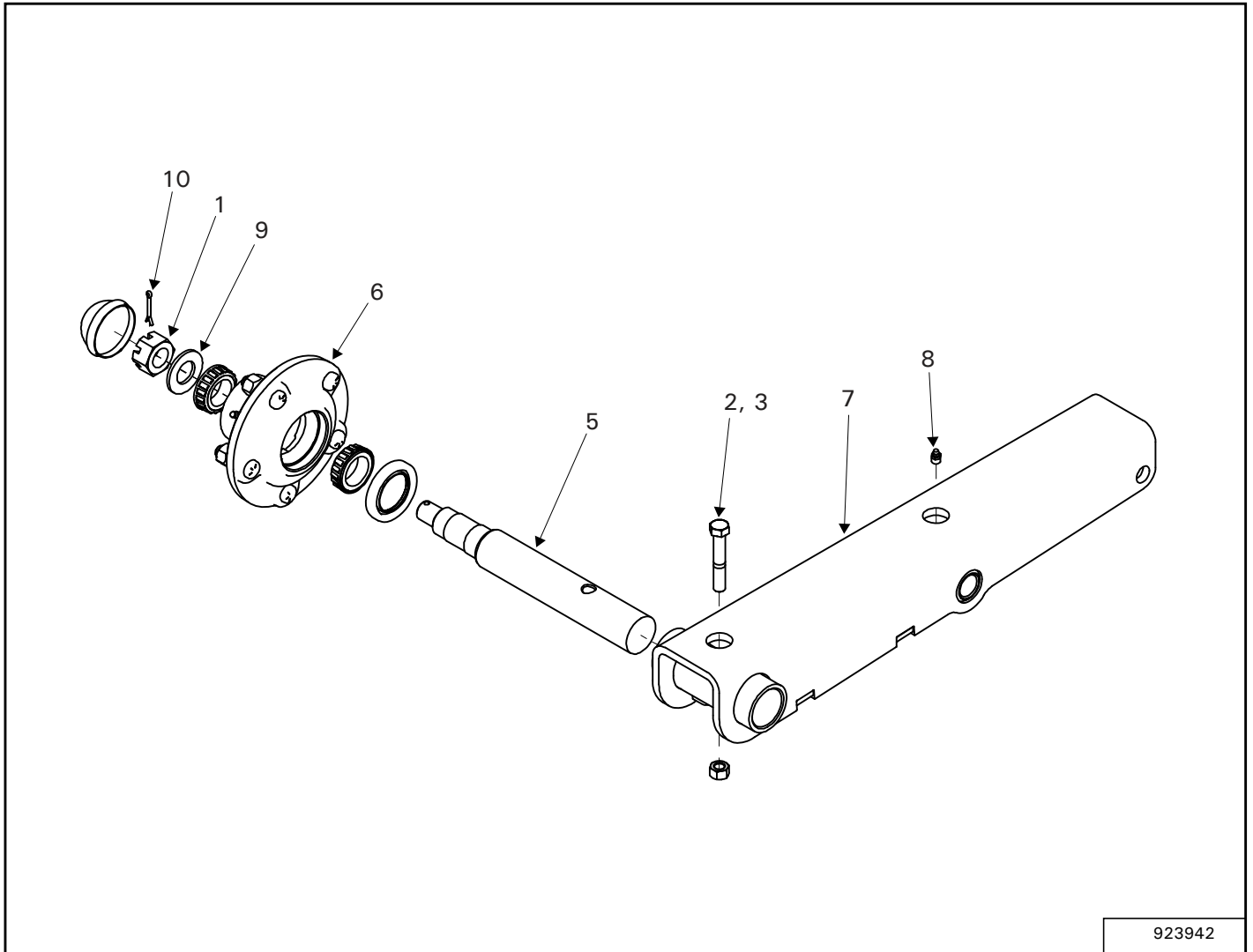

ITEM	PART NUMBER	DESCRIPTION	QTY
1	810010	NUT-SLOTTED 7/8 UNF (BR)	1
2	812364	1/2" LOCK NUT (PL)	1
3	81627	1/2" X 3" HEX BOLT (PL)	1
4	904902	GREASE GRADE 2	25g
5	915668	SHAFT-REMOVABLE SGL SPINDLE	1
6	915679	HUB-HA517	1
7	918182	WELDT-SUSPENSION ARM	1
8	967164	DRIVE-IN GREASE ZERK	1
9	967713	7/8" SAE FLAT WASHER (BR)	1
10	9812486	1/8" X 1 1/2" COTTER PIN (BR)	1

RH Single Spindle Assembly

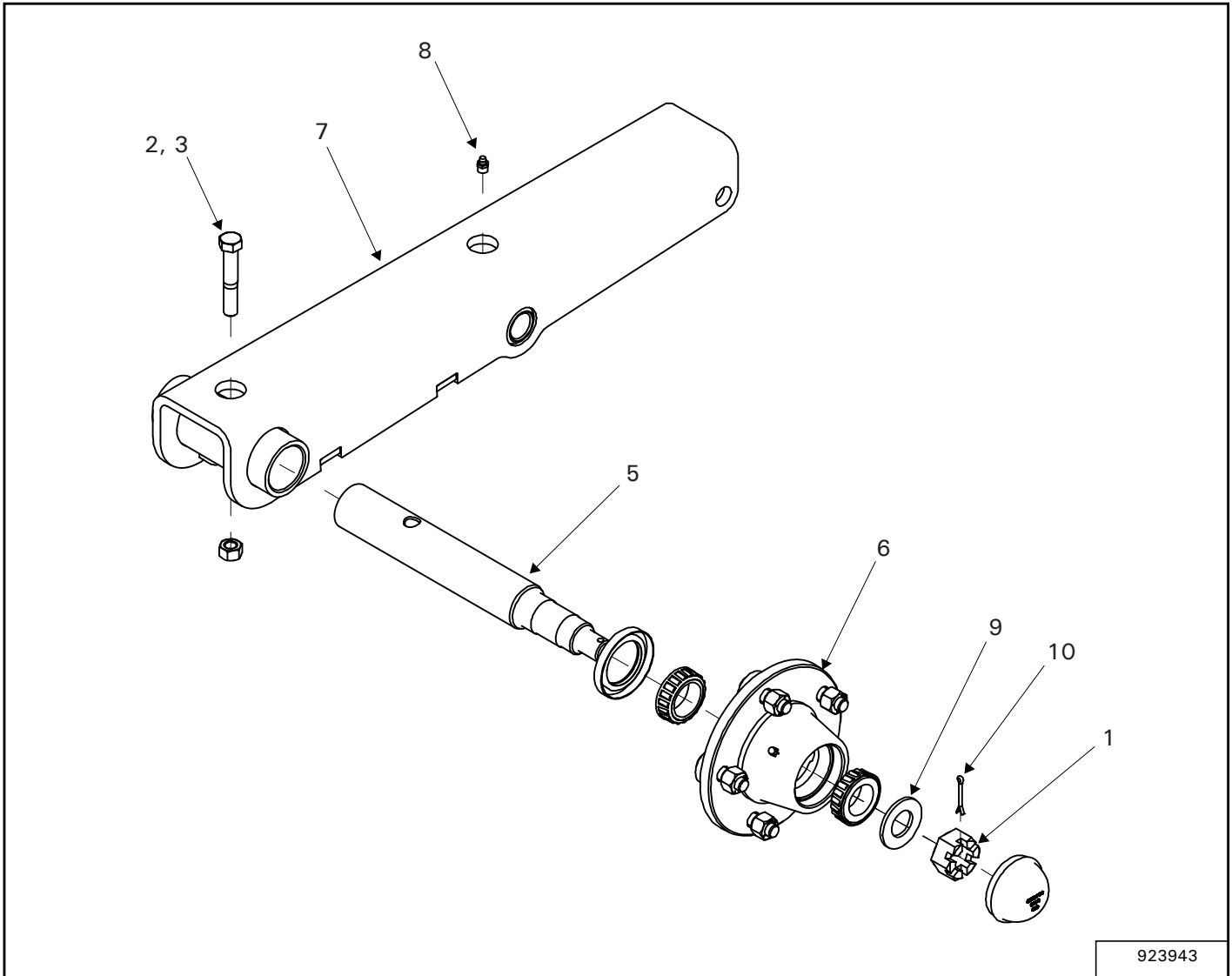

923943

ITEM	PART NUMBER	DESCRIPTION	QTY
1	810010	NUT-SLOTTED 7/8 UNF (BR)	1
2	812364	1/2" LOCK NUT (PL)	1
3	81627	1/2" X 3" HEX BOLT (PL)	1
4	904902	GREASE GRADE 2	25g
5	915668	SHAFT-REMOVABLE SGL SPINDLE	1
6	915679	HUB-HA517	1
7	918182	WELDT-SUSPENSION ARM	1
8	967164	DRIVE-IN GREASE ZERK	1
9	967713	7/8" SAE FLAT WASHER (BR)	1
10	9812486	1/8" X 1 1/2" COTTER PIN (BR)	1

LH Walking Axle Assembly

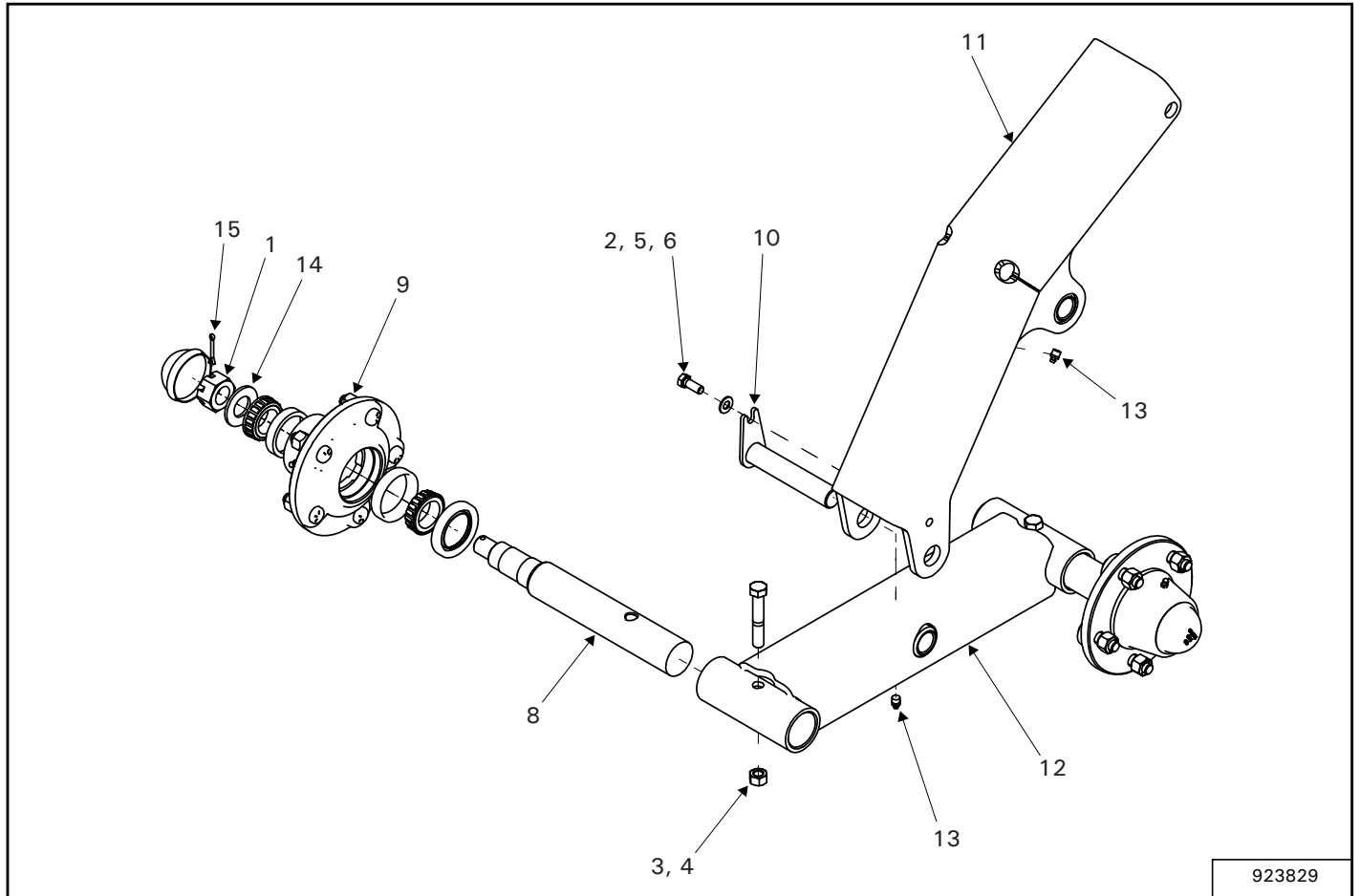

ITEM	PART NUMBER	DESCRIPTION	QTY
1	810010	NUT-SLOTTED 7/8 UNF (BR)	2
2	812363	3/8" LOCK NUT (PL)	1
3	812364	1/2" LOCK NUT (PL)	2
4	81627	1/2" X 3" HEX BOLT (PL)	2
5	84039	3/8" FLAT WASHER (PL)	1
6	86170	3/8" X 1" HEX BOLT GR.5 (PL)	1
7	904902	GREASE GRADE 2	50g
8	915668	SHAFT-REMOVABLE SGL SPINDLE	2
9	915679	HUB-HA517	2
10	918194	WELDT-AXLE PIN	1
11	923839	WELDT-WALKING SUSPENSION ARM	1
12	923849	WELDT-WALKING AXLE	1
13	967164	DRIVE-IN GREASE ZERK	2
14	967713	7/8" SAE FLAT WASHER (BR)	2
15	9812486	1/8" X 1 1/2" COTTER PIN (BR)	2

RH Walking Axle

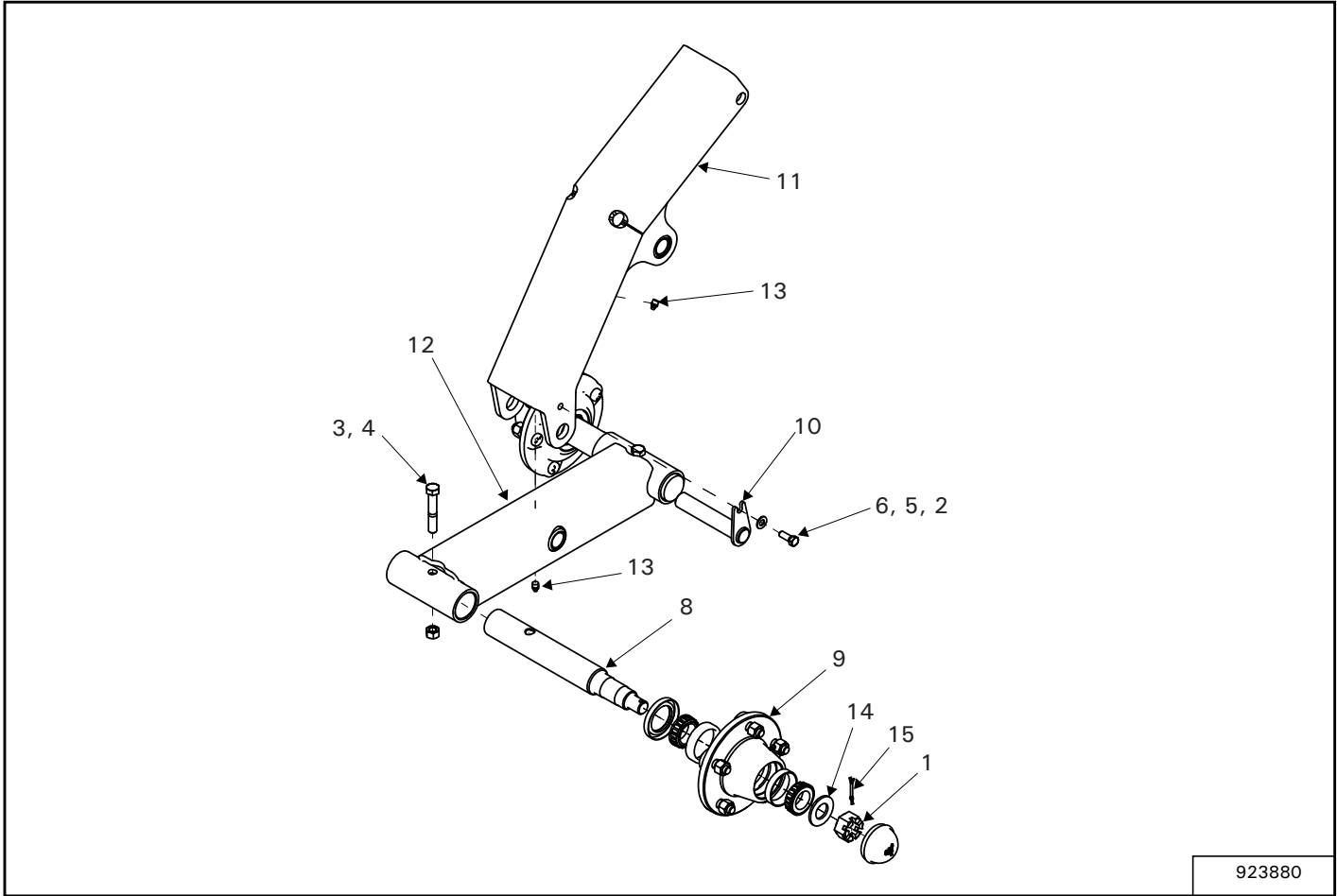

923880

ITEM	PART NUMBER	DESCRIPTION	QTY
1	810010	NUT-SLOTTED 7/8 UNF (BR)	2
2	812363	3/8" LOCK NUT (PL)	1
3	812364	1/2" LOCK NUT (PL)	2
4	81627	1/2" X 3" HEX BOLT (PL)	2
5	84039	3/8" FLAT WASHER (PL)	1
6	86170	3/8" X 1" HEX BOLT GR.5 (PL)	1
7	904902	GREASE GRADE 2	50g
8	915668	SHAFT-REMOVABLE SGL SPINDLE	2
9	915679	HUB-HA517	2
10	918194	WELDT-AXLE PIN	1
11	923839	WELDT-WALKING SUSPENSION ARM	1
12	923849	WELDT-WALKING AXLE	1
13	967164	DRIVE-IN GREASE ZERK	2
14	967713	7/8" SAE FLAT WASHER (BR)	2
15	9812486	1/8" X 1 1/2" COTTER PIN (BR)	2

DRIVELINE, HYDRAULICS, LIGHT KIT, OTHER

Driveline 540 RPM

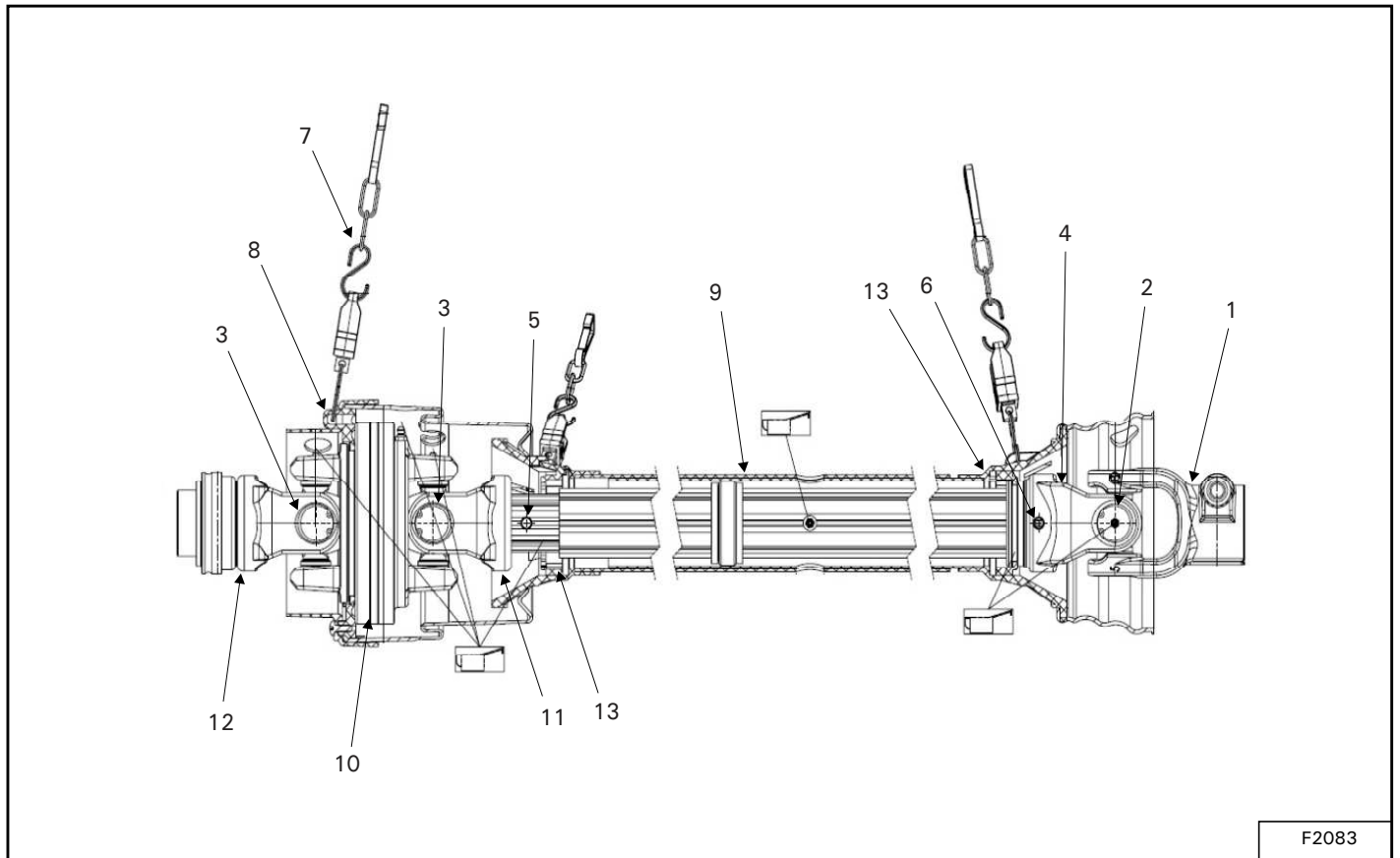

ITEM	PART NUMBER	DESCRIPTION	QTY
1	925301	SPLINED BORE YOKE W/ CONIC BOLT	1
2	925306	CROSS KIT W/ GREASE NIPPLE ON BEARING CUP	1
3	925311	CROSS KIT W/ GREASE NIPPLE ON BEARING CUP	2
4	925347	INBOARD YOKE FOR OUTER STAR TUBE	1
5	925358	ELASTIC PIN 10MM X 70MM	1
6	925360	ELASTIC PIN 10MM X 80MM	1
7	925361	PRE DISENGAGEMENT SYSTEM CHAIN	3
8	925362	WIDE ANGLE RETAINER	1
9	925363	SHAFT SHIELD	1
10	925368	CV WIDE ANGLE 80DEG	1
11	925370	CV WIDE ANGLE YOKE	1
12	925372	CV WIDE ANGLE YOKE	1
13	925422	RETAINER	2

Driveline 1000 RPM

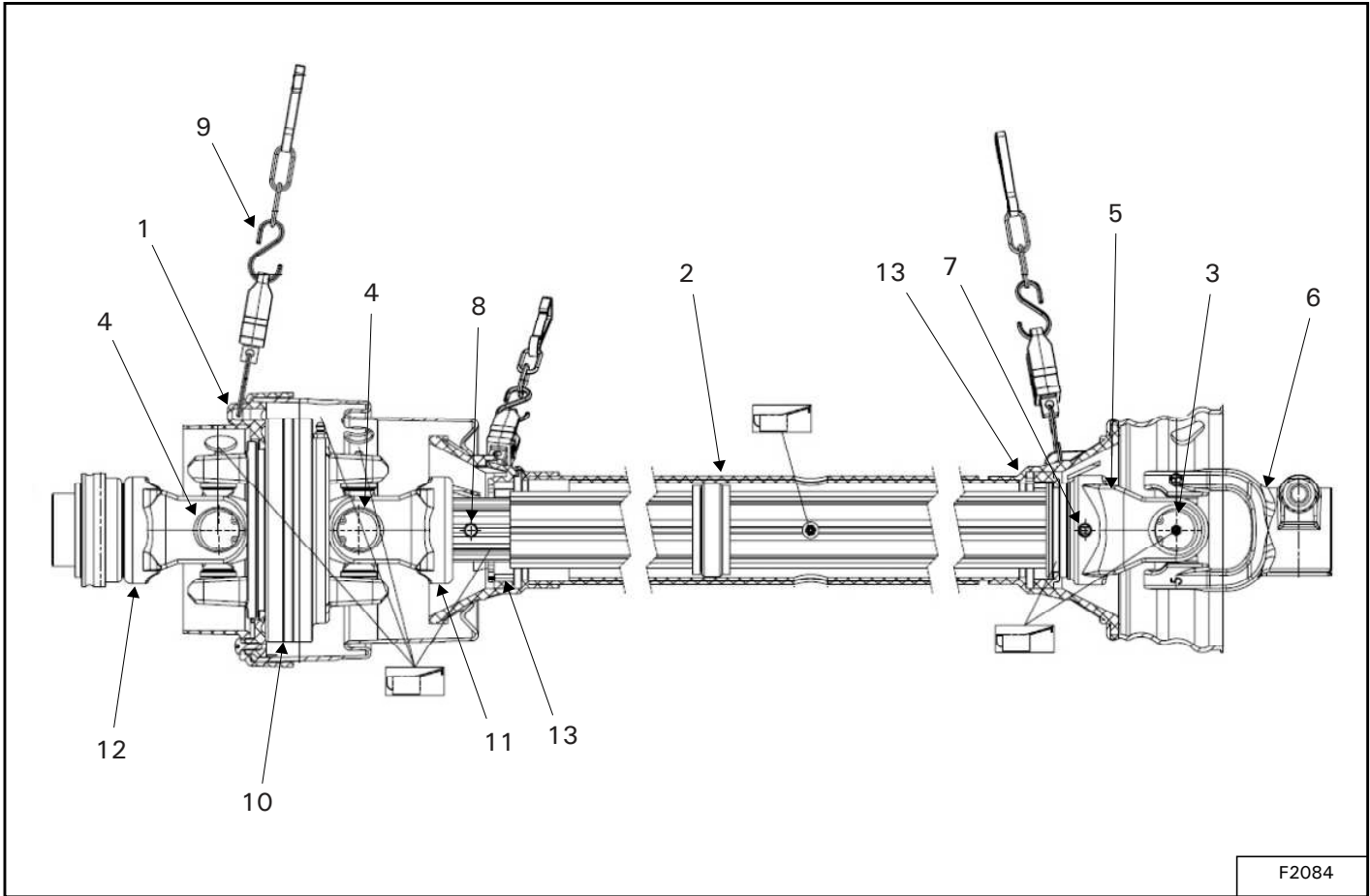

F2084

ITEM	PART NUMBER	DESCRIPTION	QTY
1	925342	WIDE ANGLE RETAINER	1
2	925351	SHAFT SHIELD	1
3	925353	CROSS W/GREASE NIPPLE ON BRG CUP	1
4	925355	CROSS KIT W/GREASE NIPPLE ON BRG CUP	2
5	925356	INBOARD YOKE FOR OUTER TUBE	1
6	925357	SPLINED BORE YOKE W/CONICAL BOLT	1
7	925358	ELASTIC PIN 10MM X 70MM	1
8	925360	ELASTIC PIN 10MM X 80MM	1
9	925361	PRE DISENGAGEMENT SYSTEM CHAIN	3
10	925366	CV WIDE ANGLE 80DEG	1
11	925369	CV WIDE ANGLE YOKE	1
12	925371	CV WIDE ANGLE YOKE	1
13	925422	RETAINER	2

Wing Driveline

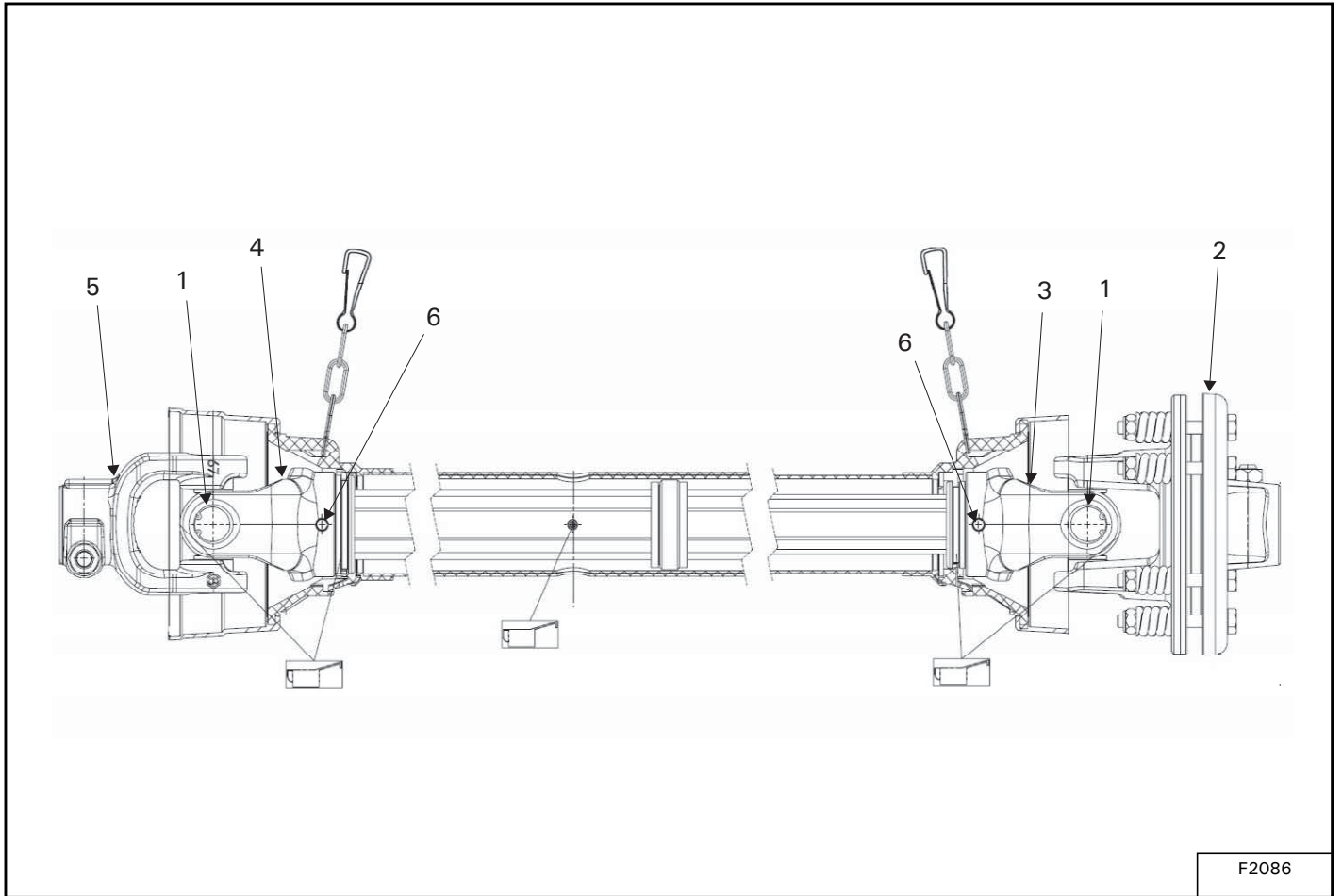

ITEM	PART NUMBER	DESCRIPTION	QTY
1	925293	CROSS KIT-W/GREASE NIPPLE	2
2	925307	FRICTION CLUTCH	1
3	925308	INBOARD YOKE FOR INNER TUBE	1
4	925340	INBOARD YOKE FOR OUTER TUBE	1
5	925341	SPLINED BORE YOKE WITH CONIC BOLT	1
6	925360	ELASTIC PIN 10MM X 80MM	2

Slip Clutch Driveline

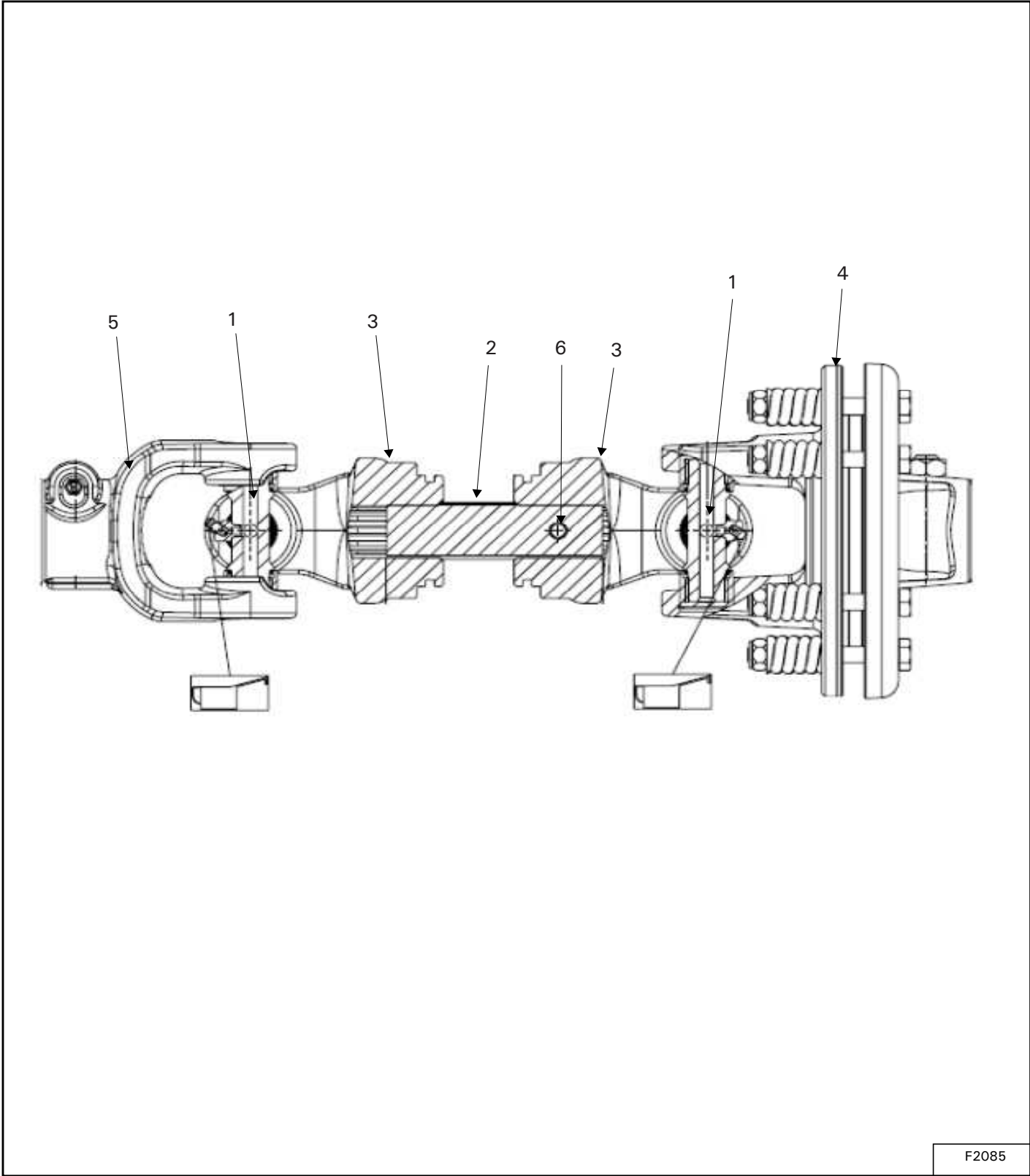

F2085

ITEM	PART NUMBER	DESCRIPTION	QTY
1	925293	CROSS KIT-W/GREASE NIPPLE	2
2	925304	SPLINED TUBE	1
3	925305	INBOARD YOKE FOR INNER TUBE	2
4	925307	FRICTION CLUTCH	1
5	925341	SPLINED BORE YOKE WITH CONIC BOLT	1
6	925360	ELASTIC PIN 10MM X 80MM	1

Hydraulic Pressure Line Assembly - 1030

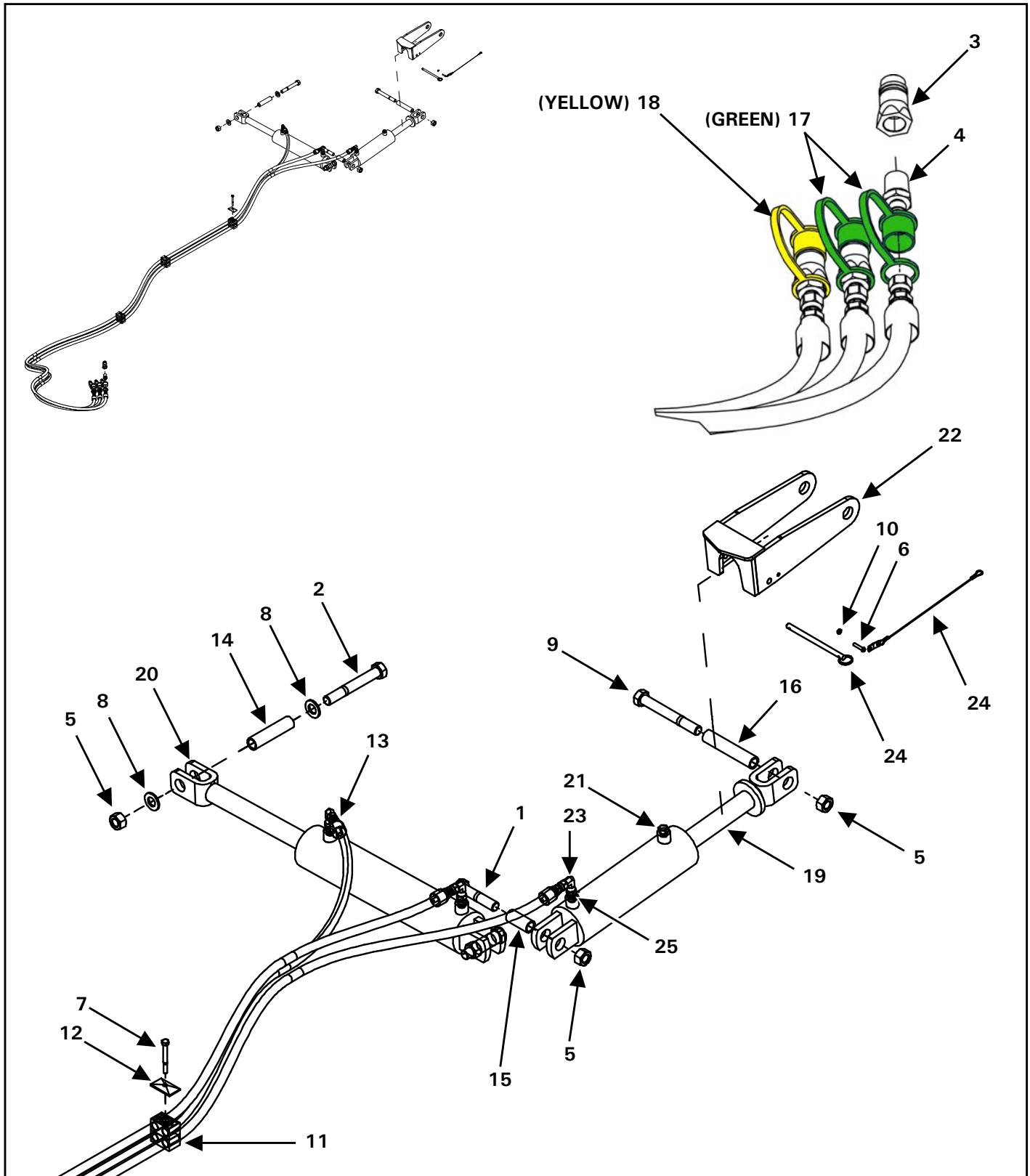

ITEM	PART NUMBER	DESCRIPTION	QTY
1	810149	BOLT, 3/4" x 3-1/2" HEX (PL)	2
2	812114	BOLT, 3/4" x 5-1/2" HEX (PL)	1
3	812208	QUICK CONNECT NIPPLE, 1/2" BODY 1/2"-14 NPTF	3
4	812320	ADAPTER, 8 MPT x 6 MJIC	3
5	812365	LOCK NUT, 3/4" (PL)	4
6	813579	MACHINE SCREW, 10-24 x 1" RD HD	1
7	81558	BOLT, 5/16" x 2-3/4" HEX GR 5 (PL)	3
8	84050	FLAT WASHER, 3/4" S.A.E. (PL)	2
9	84215	BOLT, 3/4" x 6" HEX GR 5 (PL)	1
10	84493	LOCK NUT, 10-24 (NYLON) GRB (PL)	1
11	915817	TWIN CLAMP, 0.63"	6
12	915821	TWIN CLAMP COVER	3
13	916032	HOSE, 6 x 6 JIC x 6 JIC	3
14	916188	BUSHING, 1" OD x 0.76" ID x 4.13"	1
15	916210	BUSHING, 1" OD x 0.76" ID x 2.19"	2
16	916252	BUSHING, 1" OD x 0.76" ID x 5.13	1
17	917999	GREEN DUST CAP, 1/2"	2
18	918000	YELLOW DUST CAP, 1/2"	1
19	919182	CYLINDER, 3" DIA x 18.19" TO 25"	1
20	919183	CYLINDER, 3" DIA x 23" TO 34-1/2"	1
21	919185	VENT PLUG, 6 MORB	1
22	919209	CYLINDER LOCK WELDMENT	1
23	919398	90° ELBOW, 6 FJIC x 6 MJIC	3
24	920957	PIN ASSEMBLY W / LANYARD, 0.38" DIA	1
25	921099	ADAPTER, 6 MORB x 6 MJIC R.047	3

Hydraulic Pressure Line Assembly - 1530

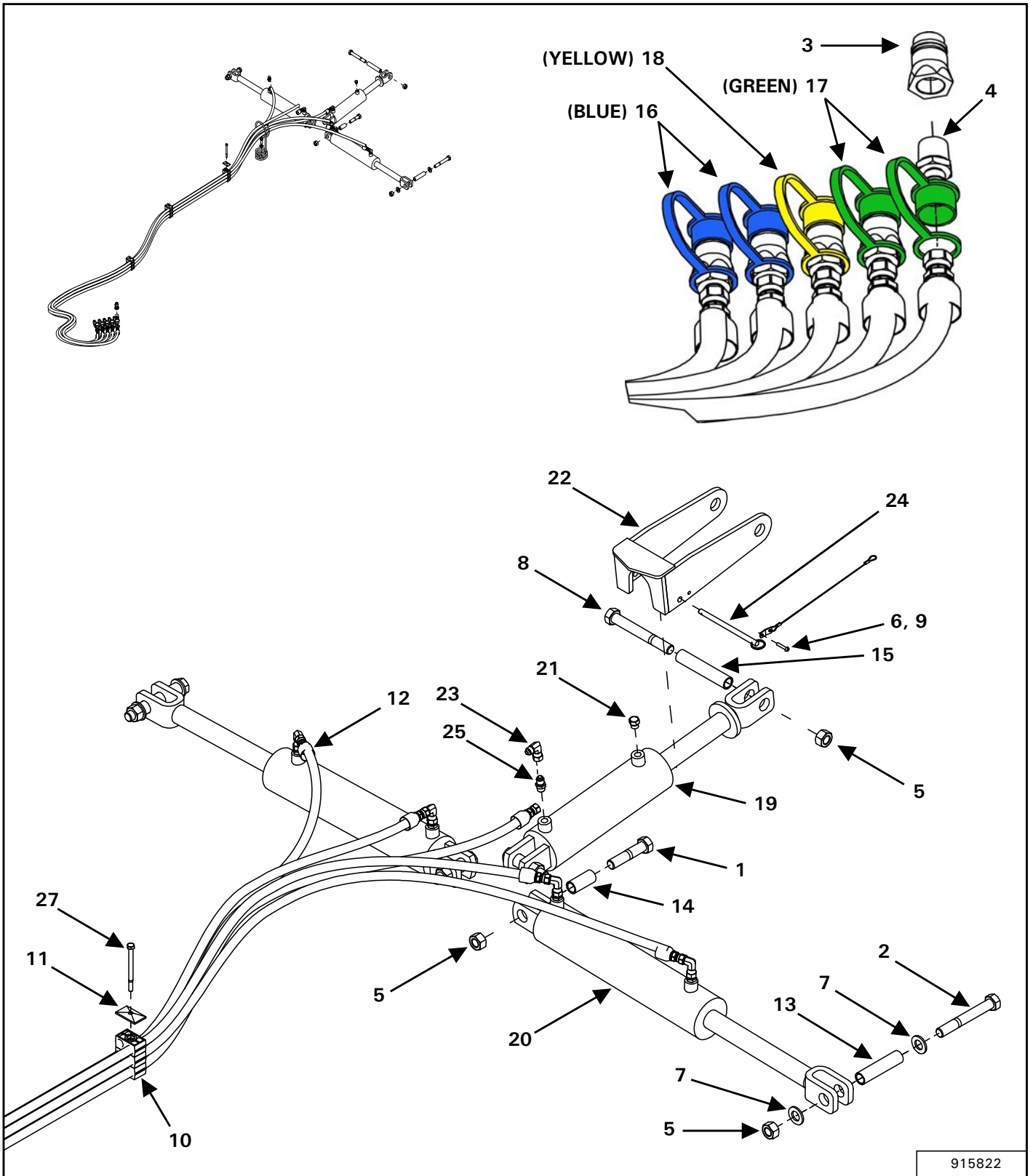

915822

ITEM	PART NUMBER	DESCRIPTION	QTY
1	810149	BOLT, 3/4" x 3-1/2" HEX (PL)	3
2	812114	BOLT, 3/4" x 5-1/2" HEX (PL)	2
3	812208	QUICK CONNECT NIPPLE, 1/2" BODY 1/2"-14 NPTF	5
4	812320	ADAPTER, 8 MPT x 6 MJIC	5
5	812365	LOCK NUT, 3/4" (PL)	6
6	813579	MACHINE SCREW, 10-24 x 1" RD HD	1
7	84050	FLAT WASHER, 3/4" S.A.E. (PL)	4
8	84215	BOLT, 3/4" x 6" HEX GR 5 (PL)	1
9	84493	LOCK NUT, 10-24 (NYLON) GRB (PL)	1
10	915817	TWIN CLAMP, 0.63"	9
11	915821	TWIN CLAMP COVER	3
12	916032	HOSE, 6 x 6 JIC x 6 JIC	5
13	916188	BUSHING, 1" OD x 0.76" ID x 4.13"	2
14	916210	BUSHING, 1" OD x 0.76" ID x 2.19"	3
15	916252	BUSHING, 1" OD x 0.76" ID x 5.13	1
16	917998	BLUE DUST CAP, 1/2"	2
17	917999	GREEN DUST CAP, 1/2"	2
18	918000	YELLOW DUST CAP, 1/2"	1
19	919182	CYLINDER, 3" DIA x 18.19" TO 25"	1
20	919183	CYLINDER, 3" DIA x 23" TO 34-1/2"	2
21	919185	VENT PLUG, 6 MORB	1
22	919209	CYLINDER LOCK WELDMENT	1
23	919398	90° ELBOW, 6 FJIC x 6 MJIC	5
24	920957	PIN ASSEMBLY W / LANYARD, 0.38" DIA	1
25	921099	ADAPTER, 6 MORB x 6 MJIC R.047	5
26	967103	TIE, 30" (Not Shown)	3
27	967197	BOLT, 5/16" x 4" HEX (PL)	3

Light Kit Assembly

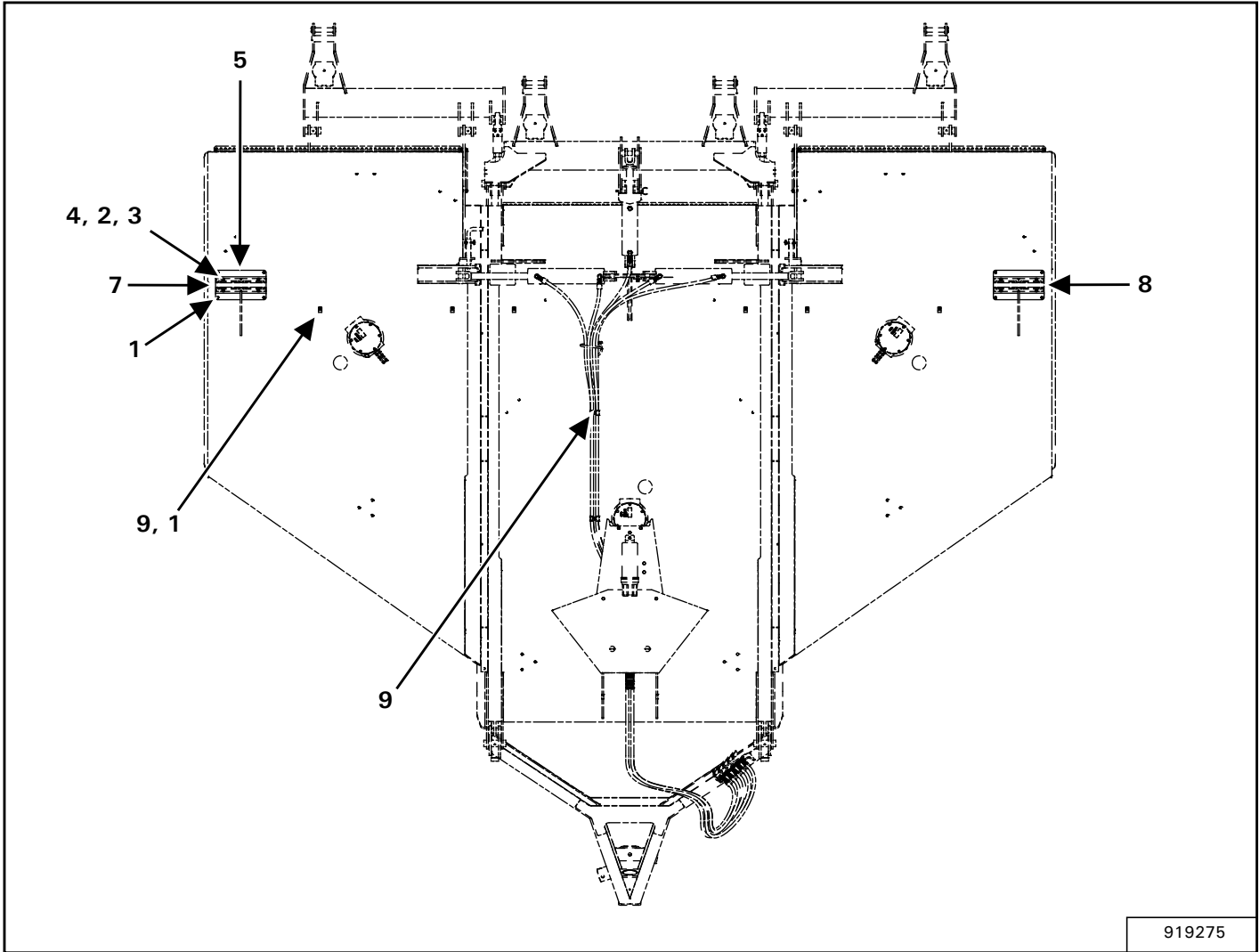

919275

ITEM	PART NUMBER	DESCRIPTION	QTY
1	81007	SELF DRILLING SCREW, 1/4" x 3/4" HEX	20
2	812624	FLAT WASHER, 1/4" (PL)	8
3	81527	BOLT, 1/4" x 1" HEX (PL)	8
4	84498	LOCK NUT, 1/4" (PL)	8
5	918362	TAIL LAMP MOUNT BRACKET	2
6	919277	TAIL LAMP / SIGNAL LIGHTS HARNESS (Not Shown)	1
7	919282	RH TAIL LAMP / WARNING LAMP	1
8	919283	LH TAIL LAMP / WARNING LAMP	1
9	919485	SUPPORT CLAMP, 3/8" DIA	9
10	967103	TIE STRAP, 30" (Not Shown)	4

Lock Bracket W/ Stump Jumper / Blades Assembly

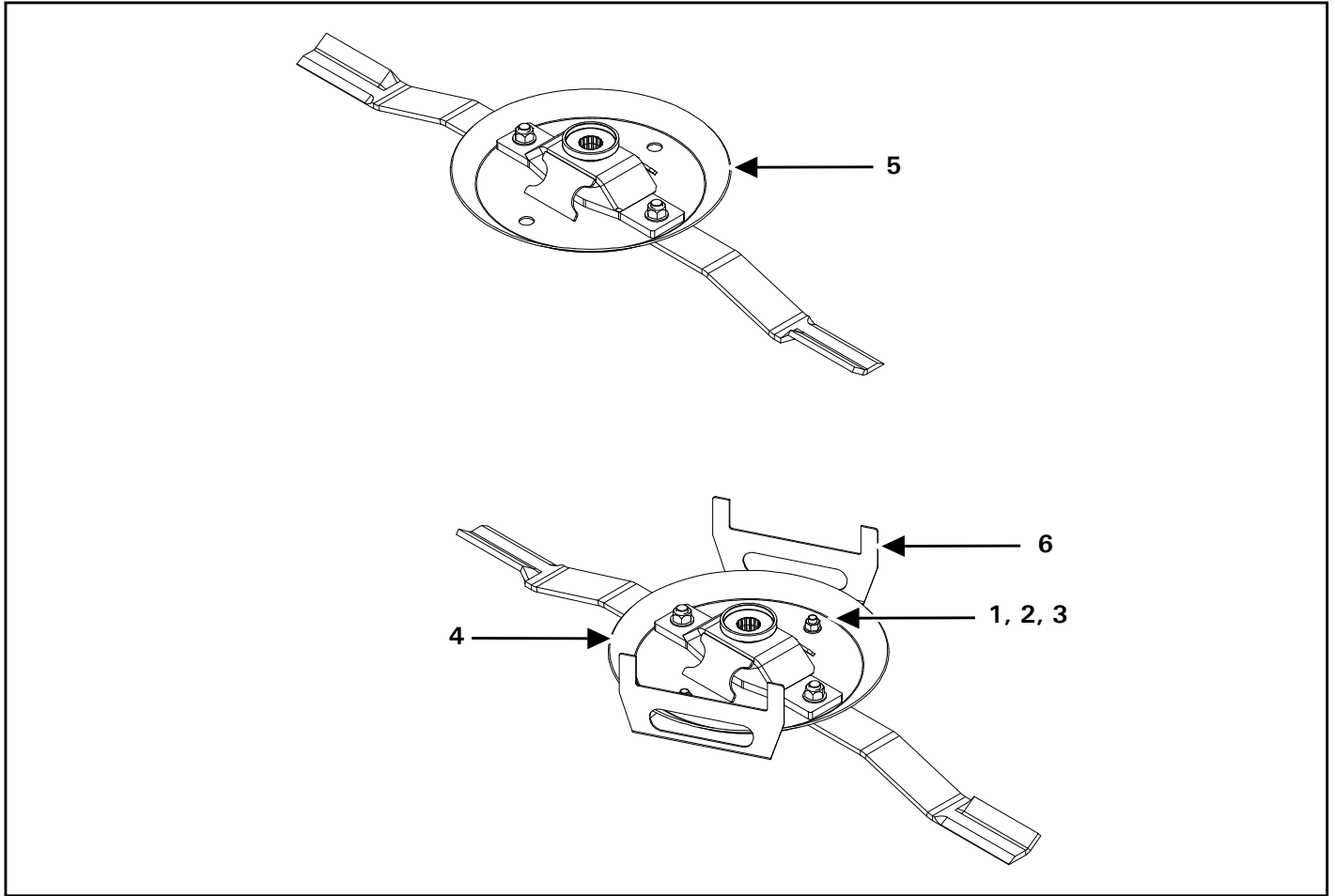

ITEM	PART NUMBER	DESCRIPTION	QTY
1	81681	BOLT, 3/4" x 1-1/2" HEX (PL)	2
2	81700	NUT, 3/4" HEX (PL)	2
3	84050	FLAT WASHER, 3/4" SAE (PL)	2
4	924288	CW STUMP JUMPER AND BLADE ASSEMBLY	1
5	924289	CCW STUMP JUMPER AND BLADE ASSEMBLY	1
6	924458	BLADE PAN LOCK BRACKET	1

Cat 2 Clevis Hitch Assembly

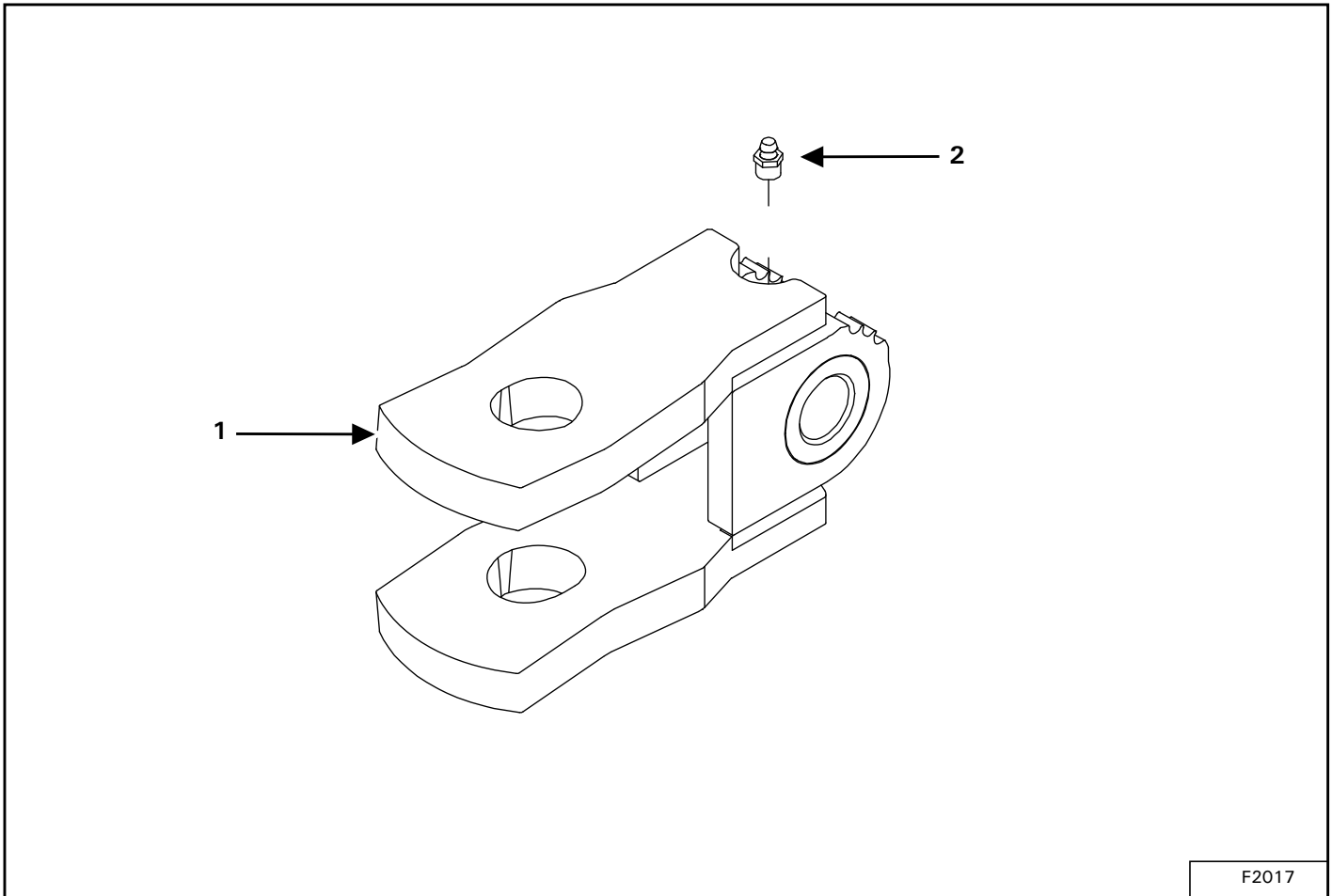

ITEM	PART NUMBER	DESCRIPTION	QTY
1	919154	CLASS 2 CLEVIS HITCH	1
2	967164	DRIVE-IN GREASE ZERK	1

Cat 2 Precision Hitch Assembly

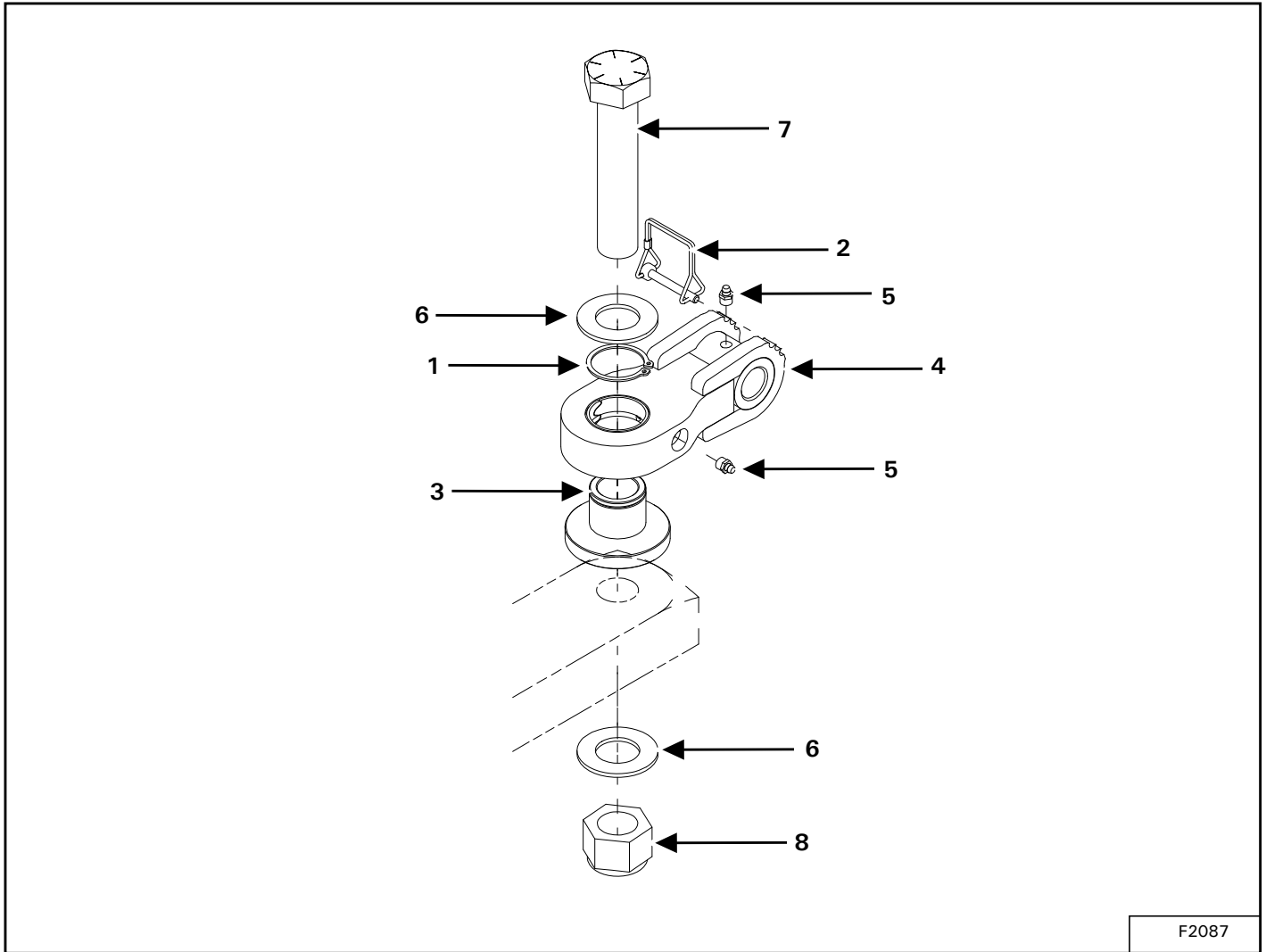

F2087

ITEM	PART NUMBER	DESCRIPTION	QTY
1	912301556	RETAINER RING, 1-3/4"	1
2	916976	SNAPPER CLIP	1
3	921157	HITCH WEAR PAD ROD	1
4	921159	-PRECISION HITCH W / BUSHING ASSEMBLY	1
5	967164	DRIVE-IN GREASE ZERK	2
6	9812487	NARROW RIM WASHER, 1-1/4" x 10 GA (PL)	2
7	SXBH1256008YZ	BOLT, 1-1/4" x 6" GR 8	1
8	SXLN-125-NI-YZ	LOCKNUT, 1-1/4" NYLON INSERT	1

Farm King



SPECIFICATIONS

1030 SPECIFICATIONS139
 Operating Dimensions139
 Overall Dimensions140
 Performance141

1530 SPECIFICATIONS142
 Operating Dimensions142
 Overall Dimensions143
 Performance144

HYDRAULIC SCHEMATIC145
 1030145
 1530146

HARDWARE TORQUE VALUES147
 Metric Chart147
 Imperial Chart148

HYDRAULIC CONNECTION SPECIFICATIONS149
 O-Ring Fitting (Straight Thread)149
 O-ring Face Seal Connection149
 Flare Fitting149
 Port Seal (O-ring Boss) Fitting149
 Tubelines And Hoses149

Farm King



1030 SPECIFICATIONS

Operating Dimensions

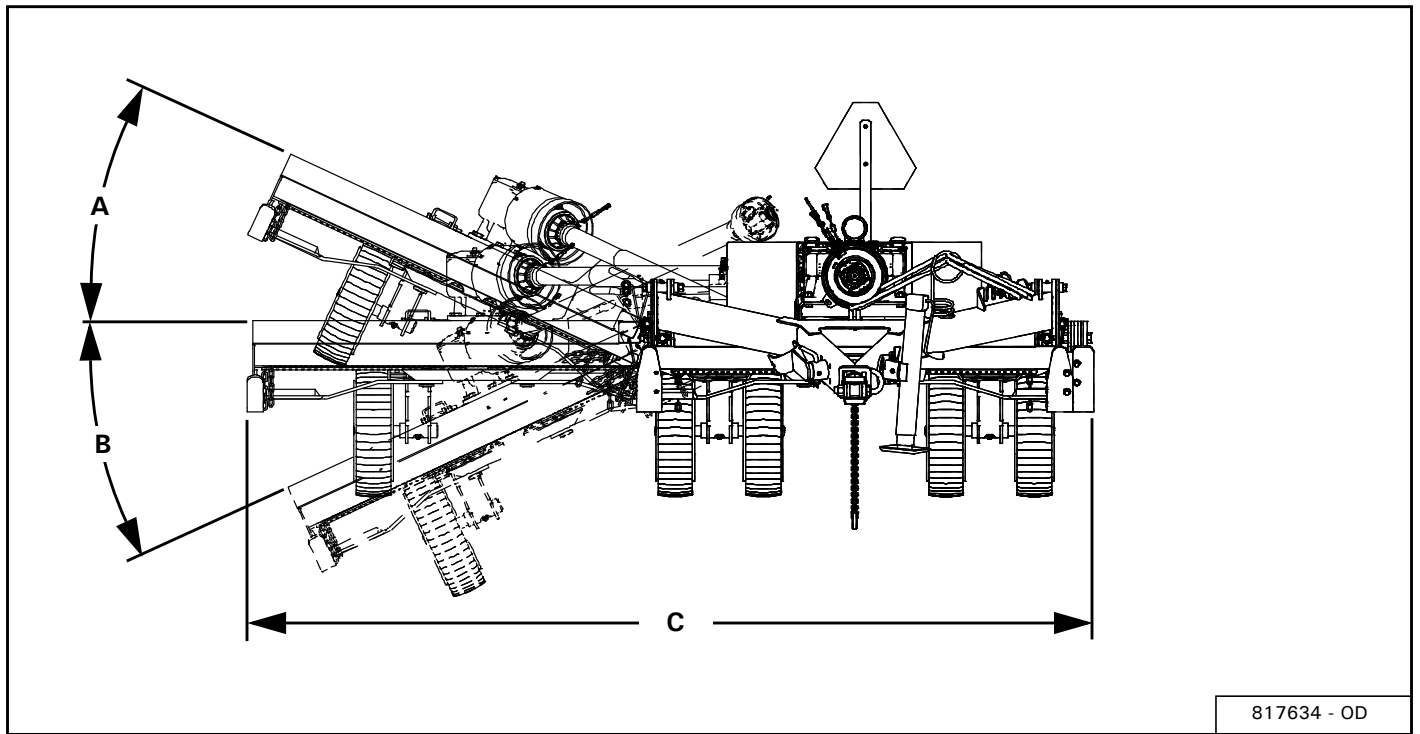

DESCRIPTION	1030
Working Range (A) & (B)	$\pm 25^\circ$
Width (C) - Working / Overall	135 in (3.4 m)

Overall Dimensions

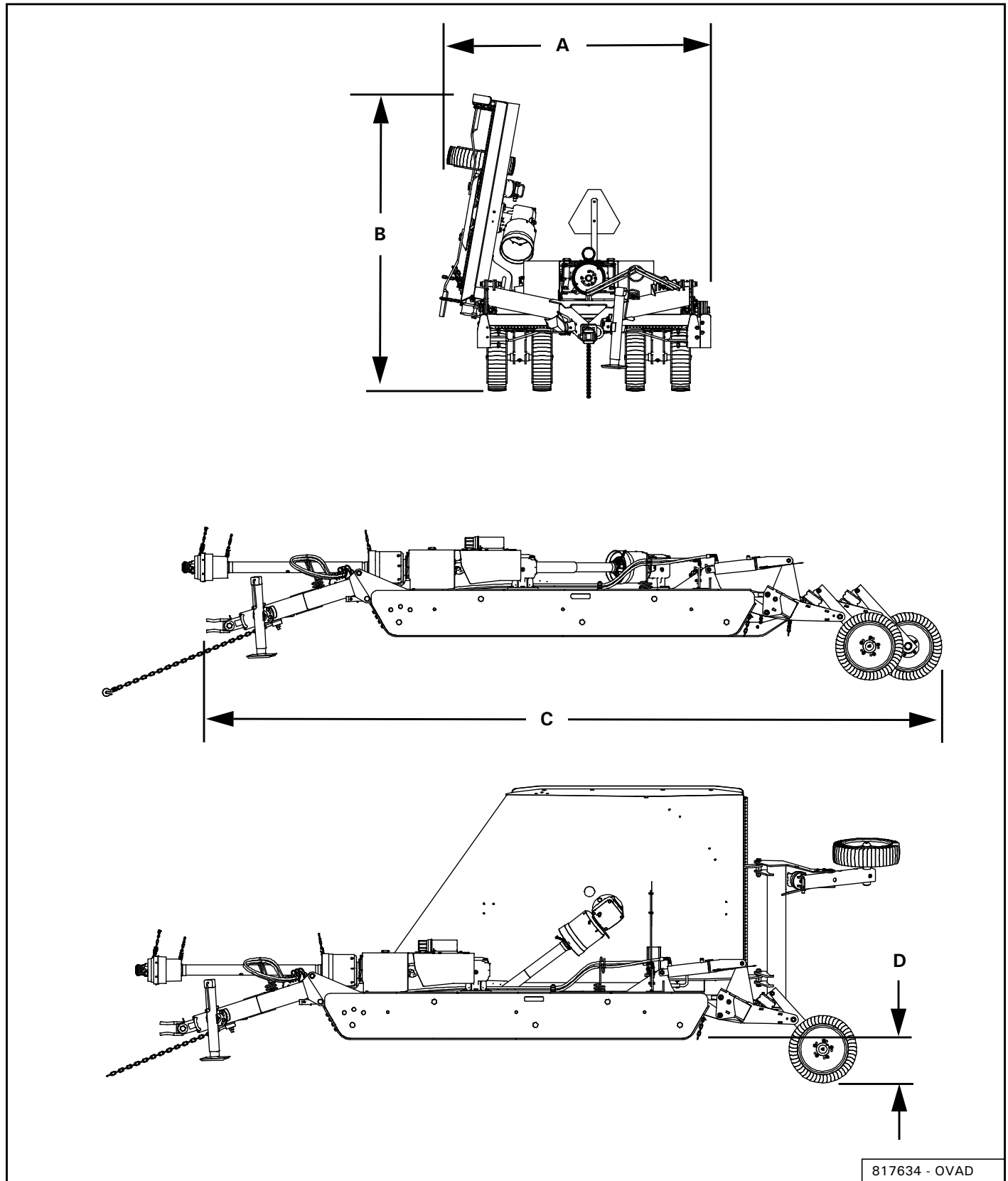

Overall Dimensions

DESCRIPTION	1030
Transport Width (A)	82 in (2.1 m)
Transport Height (B)	93 in (2.4 m)
Overall Length (C)	230 in. (5842 mm)
Transport Deck Height (D)	13.5 in. (343 mm)

Performance

DESCRIPTION	1030	
	540 RPM	1000 RPM
Cutting Height	2 - 15 in. (51 - 381 mm)	
Weight	5200 lb. (2359 kg)	
Tongue Weight	2100 lb. (953 kg)	
Tractor HP Requirement (Minimum)	65 hp	
Wing Blade Tip Speed	16,481 ft/min (5023 m/min)	16,737 ft/min (5101 m/min)
Center Blade Tip Speed	16,197 ft/min (4937 m/min)	15,802 ft/min (4816 m/min)
Blade Overlap	7 in (177 mm)	
Blade	0.5 x 4, Uplift	
Stump Jumper	Symmetric die pressed (7 Ga.)	
Side Skid	Reversible & Replaceable	
Suspension	Independent Rubber-Isolated Wheel Assemblies	
Hitch	Double Swivel Clevis Hitch	
Tires	(6 in or 8 in.): 24 x 7.7 x 10 Aircraft Tires (Air Filled)	
	21 in. Laminated Wheels (Solid Rubber)	

1530 SPECIFICATIONS

Operating Dimensions

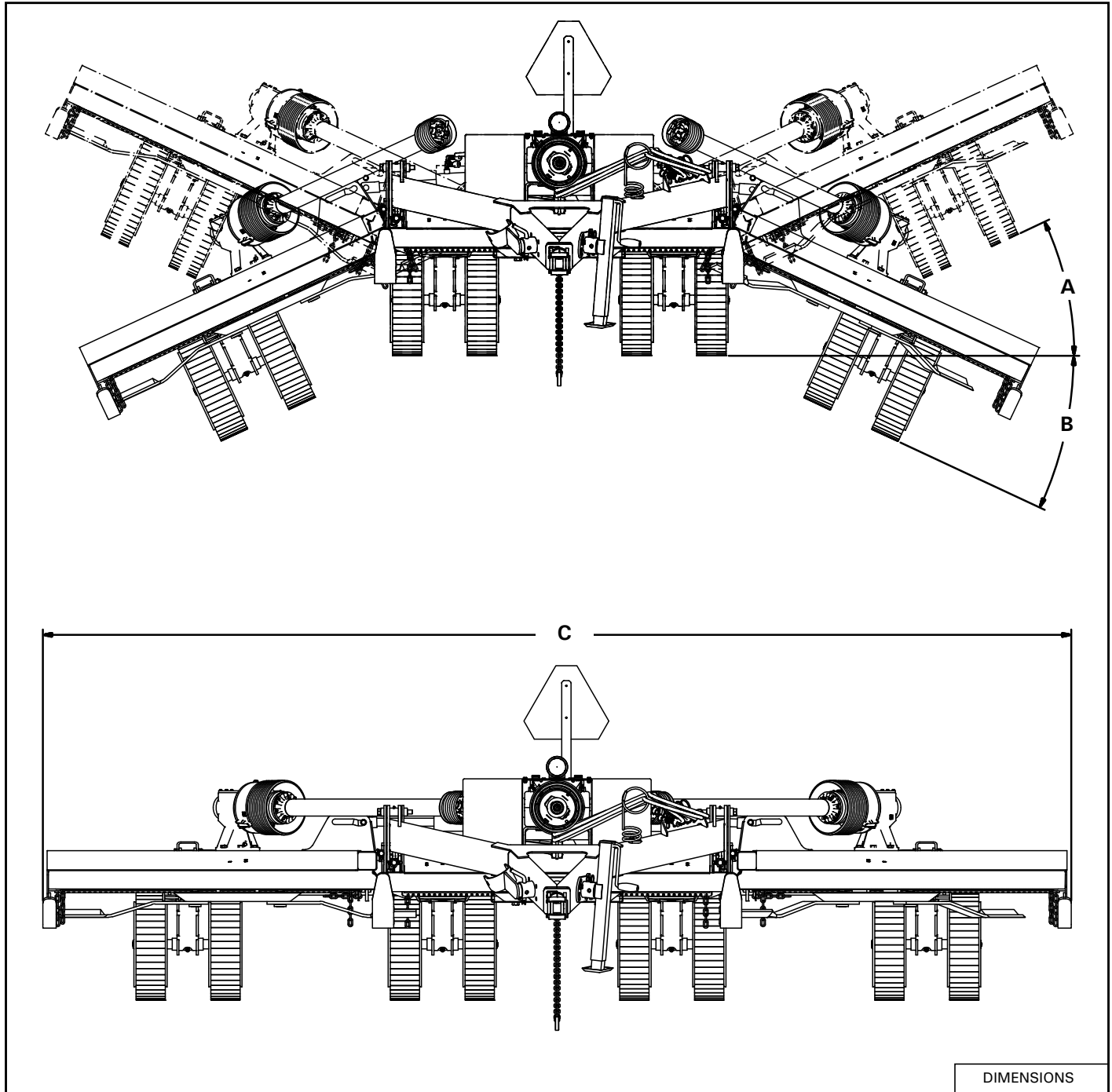

DIMENSIONS

DESCRIPTION	1530
Working Range (A) & (B)	± 25°
Width (C) - Working / Overall	186 in (4.7 m) / 194 in (4.9 m)

Overall Dimensions

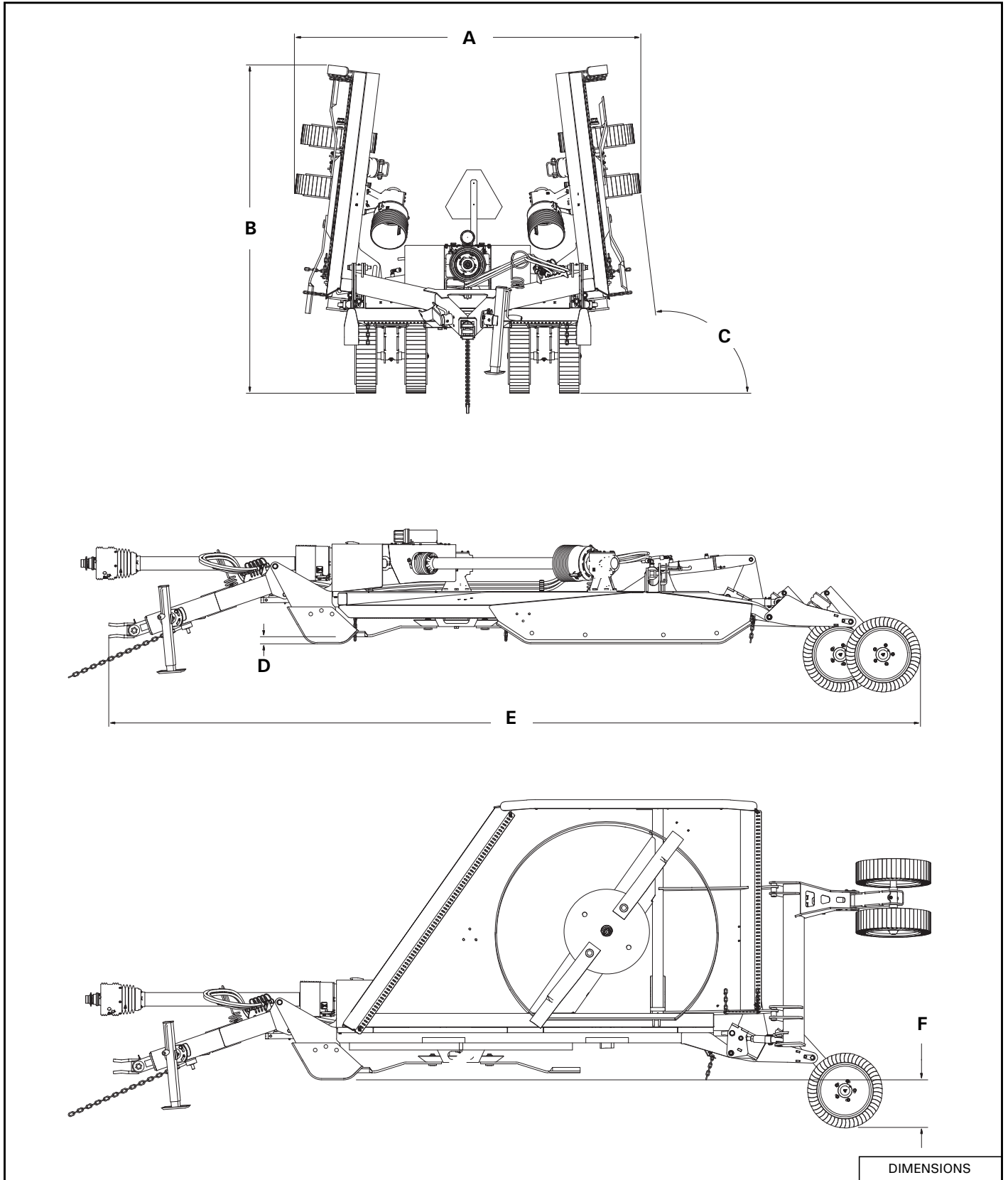

Overall Dimensions

DESCRIPTION	1530
Transport Width (A)	96 in (2.4 m)
Transport Height (B)	93 in (2.4 m)
Wing Angle Folded (C)	97°
Skid Shoe Depth Below Deck (D)	2 in. (50.8 mm)
Overall Length (E)	230 in. (5842 mm)
Transport Height (F)	13.5 in. (343 mm)

Performance

DESCRIPTION	1530	
	540 RPM	1000 RPM
Cutting Height	2 - 15 in. (51 - 381 mm)	
Weight	5900 lb. (2676 kg)	
Tongue Weight	2100 lb. (953 kg)	
Tractor HP Requirement (Minimum)	65 hp	
Wing Blade Tip Speed	16,481 ft/min (5023 m/min)	16,737 ft/min (5101 m/min)
Center Blade Tip Speed	16,197 ft/min (4937 m/min)	15,802 ft/min (4816 m/min)
Blade Overlap	7 in (177 mm)	
Blade	0.5 x 4, Uplift	
Stump Jumper	Symmetric die pressed (7 Ga.)	
Side Skid	Reversible & Replaceable	
Suspension	Independent Rubber-Isolated Wheel Assemblies	
Hitch	Double Swivel Clevis Hitch	
Tires	(6 in or 8 in.): 24 x 7.7 x 10 Aircraft Tires (Air Filled) 21 in. Laminated Wheels (Solid Rubber)	

HYDRAULIC SCHEMATIC

1030

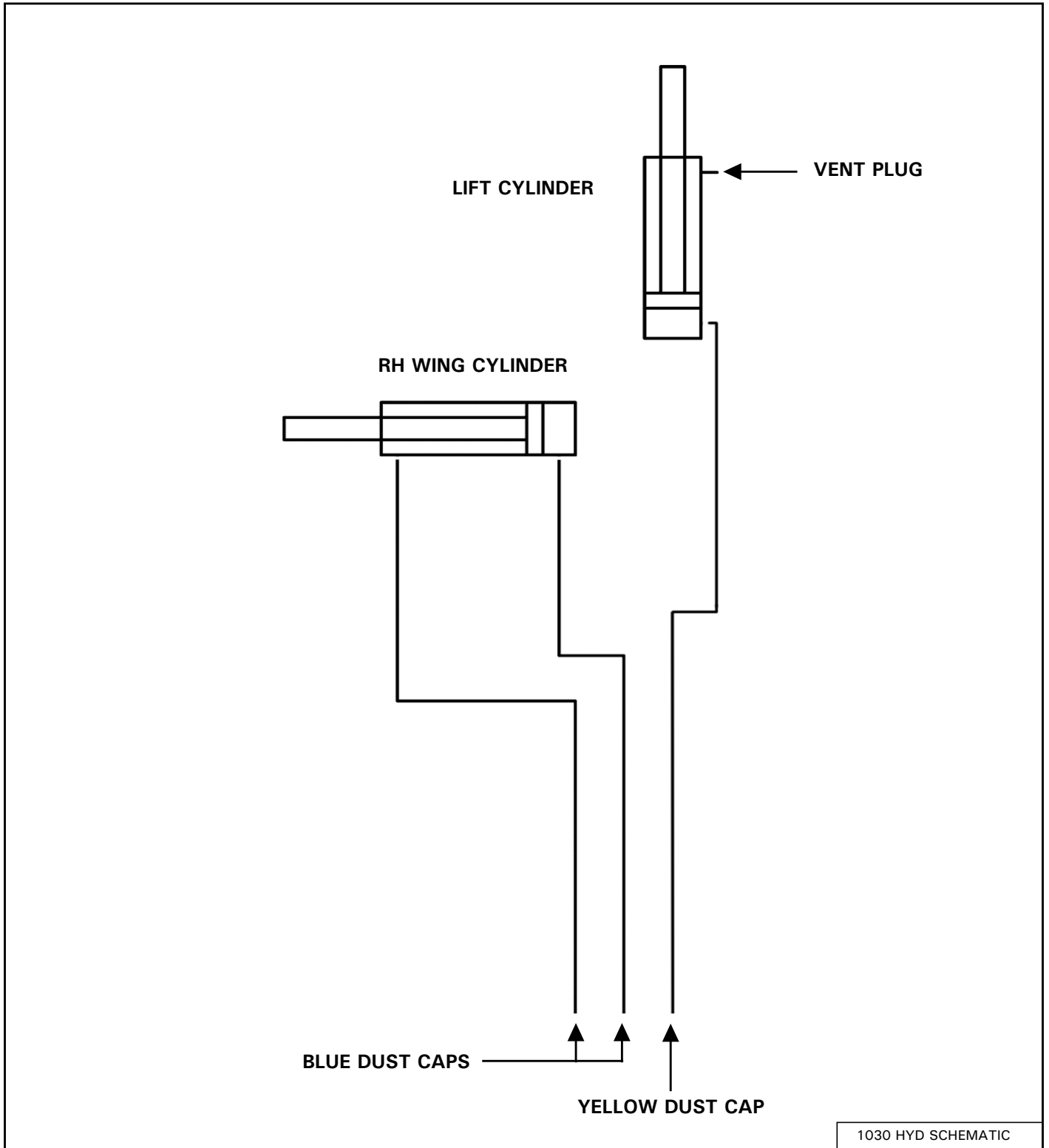

1530

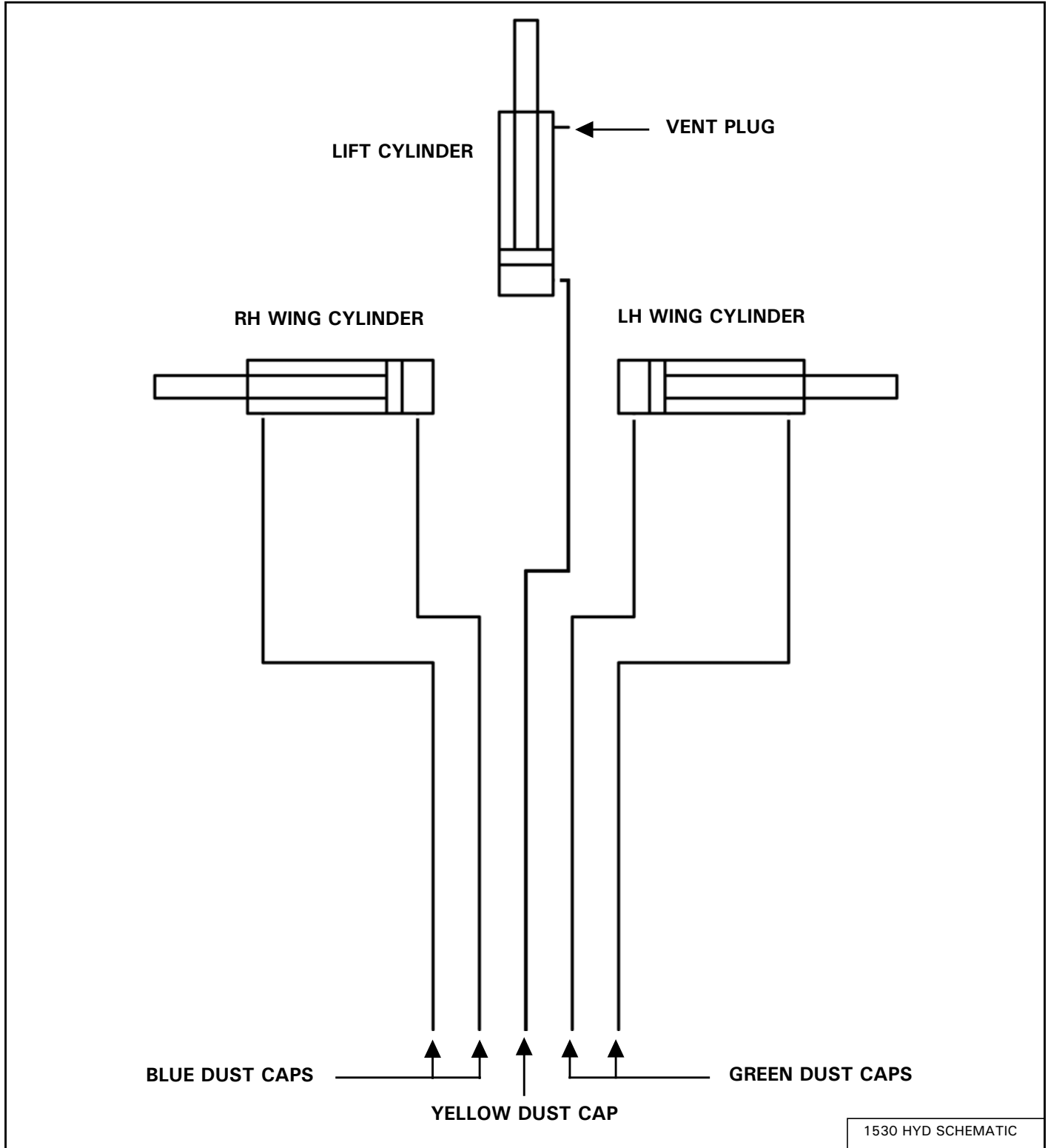

1530 HYD SCHEMATIC

HARDWARE TORQUE VALUES

Metric Chart

NOTE: Do not use the values listed in the charts if a different torque value or tightening procedure is specified in this manual for a specific application. Torque values listed are for general use only.

Use the following charts to determine the correct torque when checking, adjusting or replacing hardware. Torque values are listed in newton-meters (inch* or foot pounds) for normal assembly applications.

Nominal Size	Class 5.8		Class 8.8		Class 10.9		Lock nuts
	Unplated	Plated W / ZnCr	Unplated	Plated W / ZnCr	Unplated	Plated W / ZnCr	CL.8 w/ CL. 8.8 Bolt
M4	1.7 (15*)	2.2 (19*)	2.6 (23*)	3.4 (30*)	3.7 (33*)	4.8 (42*)	1.8 (16*)
M6	5.8 (51*)	7.6 (67*)	8.9 (79*)	12 (102*)	13 (115*)	17 (150*)	6.3 (56*)
M8	14 (124*)	18 (159*)	22 (195*)	28 (248*)	31 (274*)	40 (354*)	15 (133*)
M10	28 (21)	36 (27)	43 (32)	56 (41)	61 (45)	79 (58)	30 (22)
M12	49 (36)	63 (46)	75 (55)	97 (72)	107 (79)	138 (102)	53 (39)
M16	121 (89)	158 (117)	186 (137)	240 (177)	266 (196)	344 (254)	131 (97)
M20	237 (175)	307 (226)	375 (277)	485 (358)	519 (383)	671 (495)	265 (195)
M24	411 (303)	531 (392)	648 (478)	839 (619)	897 (662)	1160 (855)	458 (338)

NOTE: Torque values shown with * are inch pounds.

Identification of Hex Cap Screws and Carriage Bolts - Classes 5 and up

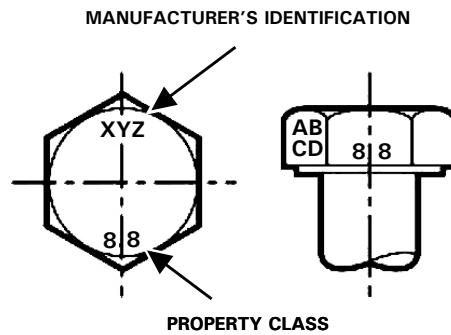

Identification of Hex Nuts and Lock Nuts - Classes 5 and up

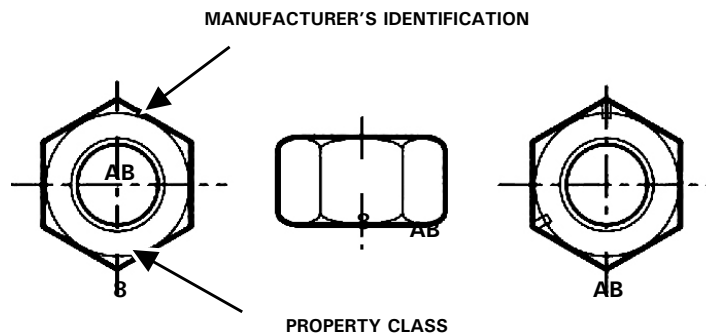

HARDWARE TORQUE VALUES (CONT'D)

Imperial Chart

NOTE: Do not use the values listed in the charts if a different torque value or tightening procedure is specified in this manual for a specific application. Torque values listed are for general use only.

Use the following charts to determine the correct torque when checking, adjusting or replacing hardware. Torque values are listed in newton-meters (inch* or foot pounds) for normal assembly applications.

Nominal Size	SAE Grade 5		SAE Grade 8		LOCK NUTS			
	Unplated or Plated Silver	Plated W / ZnCr Gold	Unplated or Plated Silver	Plated W / ZnCr Gold	Unplated or Plated Silver	Plated W / ZnCr Gold	Grade W / Gr. 5 Bolt	Grade W / Gr. 8 Bolt
1/4	6.2 (55*)	8.1 (72*)	9.7 (86*)	12.6 (112*)	13.6 (121*)	17.7 (157*)	6.9 (61*)	9.8 (86*)
5/16	13 (115*)	17 (149*)	20 (178*)	26 (229*)	28 (250*)	37 (324*)	14 (125*)	20 (176*)
3/8	23 (17)	30 (22)	35 (26)	46 (34)	50 (37)	65 (48)	26 (19)	35 (26)
7/16	37 (27)	47 (35)	57 (42)	73 (54)	80 (59)	104 (77)	41 (30)	57 (42)
1/2	57 (42)	73 (54)	87 (64)	113 (83)	123 (91)	159 (117)	61 (45)	88 (64)
9/16	81 (60)	104 (77)	125 (92)	163 (120)	176 (130)	229 (169)	88 (65)	125 (92)
5/8	112 (83)	145 (107)	174 (128)	224 (165)	244 (180)	316 (233)	122 (90)	172 (127)
3/4	198 (146)	256 (189)	306 (226)	397 (293)	432 (319)	560 (413)	217 (160)	306 (226)
7/8	193 (142)	248 (183)	495 (365)	641 (473)	698 (515)	904 (667)	350 (258)	494 (364)
1	289 (213)	373 (275)	742 (547)	960 (708)	1048 (773)	1356 (1000)	523 (386)	739 (545)

NOTE: Torque values shown with * are inch pounds.

Identification of Hex Cap Screws and Carriage Bolts

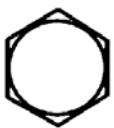

SAE GRADE 2 BOLTS



SAE GRADE 5 BOLTS



SAE GRADE 8 BOLTS



SAE GRADE 2 NUTS



SAE GRADE 5 NUTS



SAE GRADE 8 NUTS

Identification of Hex Nuts and Lock Nuts

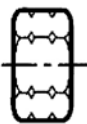

Grade A - No Notches

Grade B - One Circumferential Notch

Grade C - Two Circumferential Notches

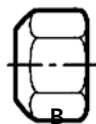

Grade A - No Mark

Grade B - Letter B

Grade C - Letter C

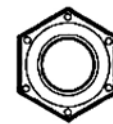

Grade A - No Marks

Grade B - Three Marks

Grade C - Six Marks

(Marks not always located at corners)

HYDRAULIC CONNECTION SPECIFICATIONS

O-Ring Fitting (Straight Thread)

Lubricate the O-ring before installing the fitting. Loosen the jam nut and install the fitting. Tighten the jam nut until the washer is tight against the surface.

O-ring Face Seal Connection

Figure 76

O-ring Face Seal Tightening Torque		
Tubeline O.D.	Thread Size	N•m (ft-lb)
1/4"	9/16" - 18	13 (18)
3/8"	11/16" - 16	22 (30)
1/2"	13/16" - 16	40 (54)
5/8"	1" - 14	60 (81)
3/4"	1-3/16" - 12	84 (114)
7/8"	1-3/16" - 12	98 (133)
1"	1-7/16" - 12	118 (160)
1-1/4"	1-11/16" - 12	154 (209)
1-1/2"	2" - 12	163 (221)

When the fitting is tightened, you can feel when the fitting is tight to eliminate leakage caused by under or over torqued fittings. Use petroleum jelly to hold the O-ring in position until the fittings are assembled.

Flare Fitting

Figure 77

Flare Fitting Tightening Torque		
Tubeline O.D.	Thread Size	N•m (ft-lb)
1/4"	7/16" - 20	13 (18)
5/16"	1/2" - 20	17 (23)
3/8"	9/16" - 18	22 (30)
1/2"	3/4" - 16	40 (54)
5/8"	7/8" - 14	60 (81)
3/4"	1-1/16" - 12	84 (114)
7/8"	1-3/16" - 12	98 (133)
1"	1-5/16" - 12	118 (160)
1-1/4"	1-5/8" - 12	154 (209)
1-1/2"	1-7/8" - 12	163 (221)
2"	2-1/2" - 12	252 (342)

Tighten until the nut makes contact with the seat. Use the chart [Figure 77] to find the correct tightness needed.

NOTE: If the fitting leaks, disconnect and inspect the

seat area for damage.

Port Seal (O-ring Boss) Fitting

Figure 78

Port Seal And O-ring Boss Tightening Torque		
Tubeline O.D.	Thread Size	N•m (ft-lb)
1/4"	7/16" - 20	13 (18)
3/8"	9/16" - 18	22 (30)
1/2"	3/4" - 16	40 (54)
5/8"	7/8" - 14	60 (81)
3/4"	1-1/16" - 12	84 (114)
7/8"	1-3/16" - 12	98 (133)
1"	1-5/16" - 12	118 (160)
1-1/8"	1-7/16" - 12	154 (209)
1-1/4"	1-5/8" - 12	163 (221)

NOTE: Port seal and nut, washer and O-ring (O-ring Boss) fittings use the same tightening torque valve chart.

If a torque wrench cannot be used, use the following method.

Tighten the nut until it just makes metal to metal contact, you can feel the resistance.

Tighten the nut with a wrench no more than one hex flat maximum.

Do not over tighten the port seal fitting.

NOTE: If a torque wrench cannot be used, use the hex flat tightening method as an approximate guideline.

NOTE: Port seal fittings are not recommended in all applications. Use O-ring boss fittings in these applications.

Tubelines And Hoses

Replace any tubelines that are bent or flattened. They will restrict flow, which will slow hydraulic action and cause heat.

Replace hoses which show signs of wear, damage or weather cracked rubber.

Always use two wrenches when loosening and tightening hose or tubeline fittings.

Farm King



WARRANTY

WARRANTY153

Farm King



WARRANTY

Farm King

Limited Warranty

BASE LIMITED WARRANTY

Farm King provides this warranty only to original retail purchasers of its products. Farm King warrants to such purchasers that all Farm King manufactured parts and components used and serviced as provided for in the Operator's Manual shall be free from defects in materials and workmanship for a period following delivery to the original retail purchaser of one (1) year. This limited warranty applies only to those parts and components manufactured by Farm King. Parts and components manufactured by others are subject to their manufacturer's warranties, if any.

Farm King will fulfill this limited warranty by, at its option, repairing or replacing any covered part that is defective or is the result of improper workmanship, provided that the part is returned to Farm King within thirty (30) days of the date that such defect or improper workmanship is, or should have been, discovered. Parts must be returned through the selling representative and the buyer must prepay transportation charges.

Farm King will not be responsible for repairs or replacements that are necessitated, in whole or part, by the use of parts not manufactured by or obtained from Farm King. Under no circumstances are component parts warranted against normal wear and tear. There is no warranty on product pump seals, product pump bearings, rubber product hoses, pressure gauges, or other components that require replacement as part of normal maintenance.

REPAIR PARTS LIMITED WARRANTY

Farm King warrants genuine Farm King replacement parts purchased after the expiration of the Farm King Limited Warranty, and used and serviced as provided for in the Operator's Manual, to be free from defects in materials or workmanship for a period of thirty (30) days from the invoice date for the parts. Farm King will fulfill this limited warranty by, at its option, repairing or replacing any covered part that is defective or is the result of improper workmanship, provided that the part is returned to Farm King within thirty (30) days of the date that such defect or improper workmanship is, or should have been, discovered. Such parts must be shipped to the Farm King factory at the purchaser's expense.

WHAT IS NOT COVERED

Under no circumstances does this limited warranty cover any components or parts that have been subject to the following: negligence; alteration or modification not approved by Farm King; misuse; improper storage; lack of reasonable and proper maintenance, service, or repair; normal wear; damage from failure to follow operating instructions; accident; and/or repairs that have been made with parts other than those manufactured, supplied, and / or authorized by Farm King.

AUTHORIZED DEALER AND LABOR COSTS

Repairs eligible for labor under this limited warranty must be made by Farm King or an authorized Farm King dealer. Farm King retains the exclusive discretion to determine whether it will pay labor costs for warranty repairs or replacements, and the amount of such costs that it will pay and the time in which the repairs will be made. If Farm King determines that it will pay labor costs for warranty work, it will do so by issuing a credit to the dealer's or distributor's account. Farm King will not approve or pay invoices sent for repairs that Farm King has not previously approved. Warranty service does not extend the original term of this limited warranty.

Farm King

Limited Warranty

WARRANTY REQUIREMENTS

To be covered by warranty, each new product must be registered with Farm King within thirty (30) days of delivery to original retail purchaser. If the customer decides to purchase replacement components before the warranty disposition of such components is determined, Farm King will bill the customer for such components and then credit the replacement invoice for those components later determined to be covered by this limited warranty. Any such replacement components that are determined not to be covered by this limited warranty will be subject to the terms of the invoice and shall be paid for by the purchaser.

EXCLUSIVE EFFECT OF WARRANTY AND LIMITATION OF LIABILITY

TO THE EXTENT PERMITTED BY LAW, FARM KING DISCLAIMS ANY WARRANTIES, REPRESENTATIONS, OR PROMISES, EXPRESS OR IMPLIED, AS TO THE QUALITY, PERFORMANCE, OR FREEDOM FROM DEFECT OF THE COMPONENTS AND PARTS COVERED BY THIS WARRANTY AND NOT SPECIFICALLY PROVIDED FOR HEREIN.

TO THE EXTENT PERMITTED BY LAW, FARM KING DISCLAIMS ANY IMPLIED WARRANTIES OF MERCHANTABILITY AND FITNESS FOR A PARTICULAR PURPOSE ON ITS PRODUCTS COVERED HEREIN, AND DISCLAIMS ANY RELIANCE BY THE PURCHASER ON FARM KING'S SKILL OR JUDGMENT TO SELECT OR FURNISH GOODS FOR ANY PARTICULAR PURPOSE. THE PURCHASER'S ONLY AND EXCLUSIVE REMEDIES IN CONNECTION WITH THE BREACH OR PERFORMANCE OF ANY WARRANTY ON FARM KING'S PRODUCTS ARE THOSE SET FORTH HEREIN. IN NO EVENT SHALL FARM KING BE LIABLE FOR INCIDENTAL OR CONSEQUENTIAL DAMAGES (INCLUDING, BY WAY OF EXAMPLE ONLY AND NOT LIMITATION, LOSS OF CROPS, LOSS OF PROFITS OR REVENUE, OTHER COMMERCIAL LOSSES, INCONVENIENCE, OR COST OF REPLACEMENT OF RENTAL EQUIPMENT). IN NO EVENT SHALL FARM KING'S CONTRACT OR WARRANTY LIABILITY EXCEED THE PURCHASE PRICE OF THE PRODUCT. (Note that some states do not allow limitations on how long an implied warranty lasts or the exclusion or limitation of incidental or consequential damages, so the above limitations and exclusion may not apply to you.) This warranty gives you specific legal rights and you may also have other rights, which vary from state to state.

Farm King neither assumes nor authorizes any person or entity, including its selling representatives, to assume any other obligations or liability in connections with the sale of covered equipment, or to make any other warranties, representations, or promises, express or implied, as to the quality, performance, or freedom from defect of the components and parts covered herein. No one is authorized to alter, modify, or enlarge this limited warranty, or its exclusions, limitations and reservations.

Corrections of defects and improper workmanship in the manner, and for the applicable time periods, provided for herein shall constitute fulfillment of all responsibilities of Farm King to the purchaser, and Farm King shall not be liable in negligence, contract, or on any other basis with respect to the subject equipment.

This limited warranty is subject to any existing conditions of supply which may directly affect Farm King's ability to obtain materials or manufacturer replacement parts.

Buhler Industries Inc. reserves the right to make improvements in design or changes in specifications to its products at anytime, without incurring any obligation to owners of units previously sold.

ALPHABETICAL INDEX

1030 SPECIFICATIONS	139
1530 SPECIFICATIONS	142
AXLE	112
AXLE	79
BASE FRAME	85
BLADE PAN	77
BLADES	75
CLEANING THE ROTARY CUTTER	80
DRIVELINE, HYDRAULICS, LIGHT KIT, OTHER	123
EQUIPMENT DECALS AND SIGNS	26
EQUIPMENT IDENTIFICATION	10
FIRE PREVENTION	18
GENERAL INFORMATION	37
GENERAL INFORMATION	85
HARDWARE TORQUE VALUES	147
HYDRAULIC CONNECTION SPECIFICATIONS	149
HYDRAULIC SCHEMATIC	145
INITIAL SET-UP	40
LIGHT KIT INSTALLATION	31
LUBRICATION	66
OPERATING THE ROTARY CUTTER	53
OWNER'S INFORMATION	9
PRE OPERATION	49
RIGHT ANGLE GEARBOX	74
SAFETY INSTRUCTIONS	15
SAFETY SIGN (DECAL) INSTALLATION	80
SAFETY SIGN-OFF FORM	27
SAFETY SIGNS (DECALS)	20
SERVICE SCHEDULE	65
SPLITTER GEARBOX	70
STORAGE AND RETURN TO SERVICE	81
TRANSPORTING	58
TROUBLESHOOTING	63
WARRANTY REGISTRATION FORM	5
WARRANTY	153

Farm King



www.farm-king.com

Farm King

1330 43rd Street North
Fargo, ND, 58102
Toll Free: 887.447.6008
E-mail: info@buhler.com
www.farm-king.com

Equipment shown is subject to change without notice.
©2018 Buhler Trading Inc. Printed in Canada TSX:BU

bühler | a division of Buhler Industries Inc.