

Farm King

ASSEMBLY INSTRUCTION MANUAL

13" Backsaver Augers

Electric Mover Kit and Winch



Table of Contents

Introduction4

Safety.....5

- General Safety Instructions.....6
- Start-up Safety6
- Operation Safety6
- Transport Safety.....7
- Service and Maintenance Safety7
- Storage Safety.....7
- Safety Signs8
- Installation.....8

Assembly.....9

- 13" Electric Motor Mounts.....9
- 13" Electric Swing Drive10
- 13" Electric Winch.....11
- Remote & Transmitter14

Parts.....16

- Indicator & Clip Bracket.....16
- 13" Electric Motor Mount Assembly.....17
- 13" Electric Mover / Winch Combo Kit.....18
- 13" Prox Sensor Mount Assembly19
- 13" Control Box Mount Assembly20
- 13" Electric Winch Mount Assembly.....21
- 13" Electric Swing Remote & Charger.....22

Manufacturer’s statement: for technical reasons Buhler Industries Inc. reserves the right to modify machinery design and specifications provided herein without any preliminary notice. Information provided herein is of descriptive nature. Performance quality may depend on soil fertility, applied agricultural techniques, weather conditions and other factors.

Introduction

The new line of electric power movers from Farm King allows remote positioning of the swing auger hopper and remote operation of the swing transport hoist. The system is 100% electric and with no hydraulic flow required. The hoppers can be positioned for use or lifted into transport position without the need to start and idle the tractor first. The remote boasts a range of 300+ feet, and can operate in extreme weather, heat and cold. The mover's drive motors mount to the hopper body itself, putting the weight of the self-leveling hopper and the grain on the tires for excellent traction. Each drive motor is independently driven so both tires will always have equal power applied. The supplied halogen work light powers on automatically with any hopper movement. The hopper operating and home positions can be preset by the user; the hopper will move to the location and then stop automatically.

Keep this manual handy for frequent reference. All new operators or owners must review this manual before using the equipment and at least annually thereafter. Contact your Farm King Dealer if you need assistance, information, or additional copies of this manual. Visit our website at www.farm-king.com for a complete list of dealers in your area.

Safety

Safety Instructions

Remember, YOU are the key to safety. Good safety practices not only protect you, but also the people around you. Make these practices a working part of your safety program. Be certain that everyone operating this equipment is familiar with the recommended operating and maintenance procedures and follows all the safety precautions. Most accidents can be prevented. Do not risk injury or death by ignoring good safety practices.

The alert symbol is used throughout this manual. It indicates attention is required and identifies hazards. Follow the recommended precautions.



The safety alert symbol means...
ATTENTION! BECOME ALERT! YOUR SAFETY IS INVOLVED!



CAUTION

The caution symbol indicates a potentially hazardous situation that, if not avoided, may result in minor or moderate injury. It may also be used to alert against unsafe practices.



WARNING

The Warning Symbol indicates a potentially hazardous situation that, if not avoided, could result in death or serious injury, and includes hazards that are exposed when guards are removed. It may also be used to alert against unsafe practices.



DANGER

The Danger Symbol indicates an imminently hazardous situation that, if not avoided will result in death or serious injury. This signal word is to be limited to the most extreme situations, typically for machine components that, for functional purposes, cannot be guarded.

General Safety Instructions

- Have a first-aid kit available for use and know how to use it.
- Have a fire extinguisher available, stored in a highly visible location, and know how to use it.
- Wear appropriate protective gear. This list may include but is not limited to:
 - hard hat
 - protective shoes with slip resistant soles
 - protective glasses or goggles
 - heavy gloves
 - wet weather gear
 - hearing protection
 - respirator or filter mask
- Read and understand the Operator's Manual and all safety signs before operating, servicing, adjusting, repairing, or unplugging the equipment.
- Do not attempt any unauthorized modifications to your Farm King product as this could affect function or safety, and could affect the life of the equipment.
- Inspect and clean the working area before operating.
- Keep hands, feet, clothing, and hair away from moving parts.
- Ensure bystanders are clear of the area before operating.

Start-up Safety

- Do not let inexperienced operators or children run this equipment.
- Place all tractor and machine controls in neutral before starting.
- Do not operate inside a building unless there is adequate ventilation.
- Ensure all shields are in place and in good condition before operating.
- Stay clear of PTO shaft and machine when engaging PTO.
- The auger must be on a level surface and wheels free to move when raising or lowering. Everyone should be kept clear during these operations.

Operation Safety

- Do not permit riders.
- Do not wear loose fitting clothing during operation.
- Empty the auger before moving to prevent upending.
- Do not allow anyone other than the operator close to the auger when in operation.
- Never stand under the auger while raising or lowering.
- Never raise the intake end of the auger above waist high, as the balance shifts forward, and the auger will tip over.
- Stay away from overhead obstructions and power lines during operation and transporting. Electrocution can occur without direct contact.

Transport Safety

- Review Transport Safety instructions in tractor manual before moving.
- Check with local authorities regarding transport on public roads. Obey all applicable laws and regulations.
- Do not tow equipment that does not have brakes at speeds over 20 mph (32 km/h).
- Do not tow equipment that does not have brakes that, when fully loaded, has a mass (weight) over 3,300 lb (1,497 kg) and more than 1.5 times the mass (weight) of the towing unit.
- Make sure the SMV (Slow Moving Vehicle) emblem and all the lights and reflectors that are required by the local highway and transport authorities are in place, are clean, and can be seen clearly by all overtaking and oncoming traffic.
- Never have the equipment in operation during transport.
- Take extreme caution in maneuvering on or around tight corners so as not to catch the end of the auger on trees, buildings, power lines, etc.
- When moving the auger on the road, always use a red flag, or if absolutely necessary to move at night, accessory lights for adequate warning to operators of other vehicles.
- Always travel at a safe speed.
- Inflate transport tires to recommended pressure.

Service and Maintenance Safety

- Stop engine, set brake, remove ignition key, and wait for all moving parts to stop before servicing, adjusting, repairing, or unplugging.
- Depress the emergency stop button on the control box
- Support the equipment with blocks or safety stands before working beneath it.
- Follow good shop practices including:
 - keep service area clean and dry
 - be sure electrical outlets and tools are properly grounded
 - use adequate light for the job.
- Use only tools, jacks, and hoists of sufficient capacity for the job.
- Replace and secure all shields removed during servicing before operating.
- Use heavy leather gloves to handle sharp objects.
- Check hydraulics regularly for leaks. Use cardboard to look for leaks and use hand and eye protection.
- Relieve pressure on hydraulic system before repairing or adjusting.
- Failure to follow proper procedures when mounting a tire on a wheel or rim can produce an explosion, which may result in serious injury or death.

Storage Safety

- Store the unit in an area away from human activity.
- Do not permit children to play on or around the stored machine.
- Support the frame on stands and blocks to provide a secure base.
- When storing an auger, park it on level ground so that the bottom end will never be over its center of gravity.
- Block the wheels of the auger so that it will not move and tear the jack from its mount.

Safety Signs

- Keep all safety signs clean and legible and replace any that are damaged or missing.
- When original parts are replaced, any safety signs affixed to those parts should be replaced as well. Replacement safety signs are available from your local dealer.

Installation

- To install safety signs, ensure area is clean and dry. Decide on the exact position before you remove the backing paper. Remove the smallest portion of the split backing paper and align over the specified area. Carefully press in place.
- Slowly peel back the remaining paper and smooth the remaining portion in place. Small air pockets can be pierced with a pin and smoothed out.
- Replace safety signs immediately should they become damaged, torn or illegible. Obtain replacements from your authorized dealer using the part numbers shown.

13" Electric Motor Mounts

The electric motor mounts for the 13" hopper are universal. To install each motor, place the flat back of the mount against the front face of the hopper. The mount has three hole combinations to choose the height of the hopper. Place a 3/8" x 1" (10 x 25 mm) bolt through holes 1 and 3. Place the 3/8" (10 mm) lock nut on the backside of these bolts and tighten. Place a 3/8" x 1" (10 x 25 mm) bolt through holes 4 and 5. Place a 3/8" (10 mm) lock nut on the backside of these bolts and tighten.

***Note: Depending on the age of hopper, it may be necessary to drill out holes 4 and 5 to match the orientation of holes 1 and 2.**

Bring the cord from the back of the motor around the corner of the hopper. Place a P-clamp around the cord. Place a 3/8" x 1" (10 x 25 mm) bolt through the P-clamp and hole 2. Tighten the nut onto this bolt as well.

Install one of the tires onto the hub, with the valve stem facing away from the hopper. Ensure that the cord from the motor will not make contact with the tire. Loosen the P-clamp and pull the cord through as needed. Retighten the clamp.

Remove the bolt on the end of the hopper door hinge and install the clamp bracket with one end free hanging at the side of the transition. Reinstall the nut and bolt. Install a P-clamp onto the motor harness and bolt the clamp to the bottom of the bracket with a 3/8" x 3/4" (10 x 19 mm) hex bolt and a 3/8" (10 mm) lock nut.

The image to the right shows how the setup should look when complete. Repeat this process for the other side.

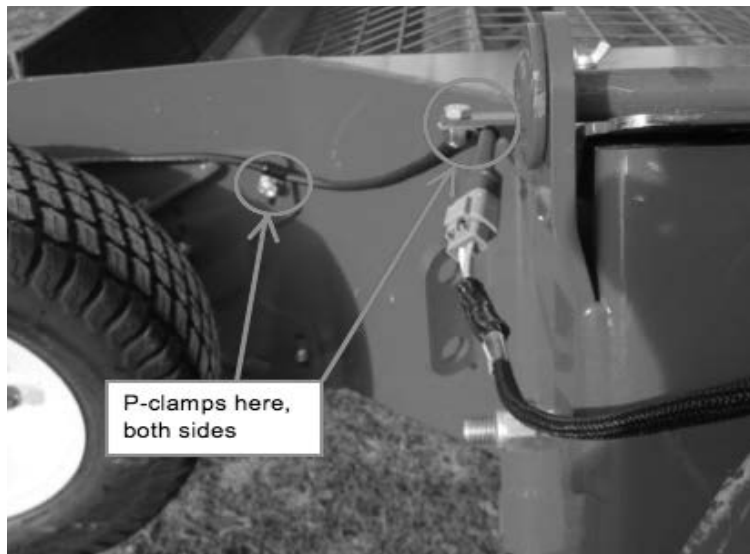
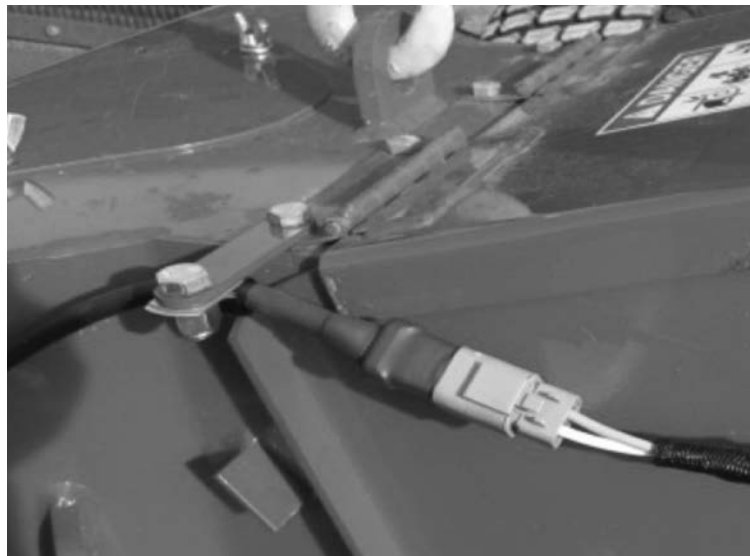
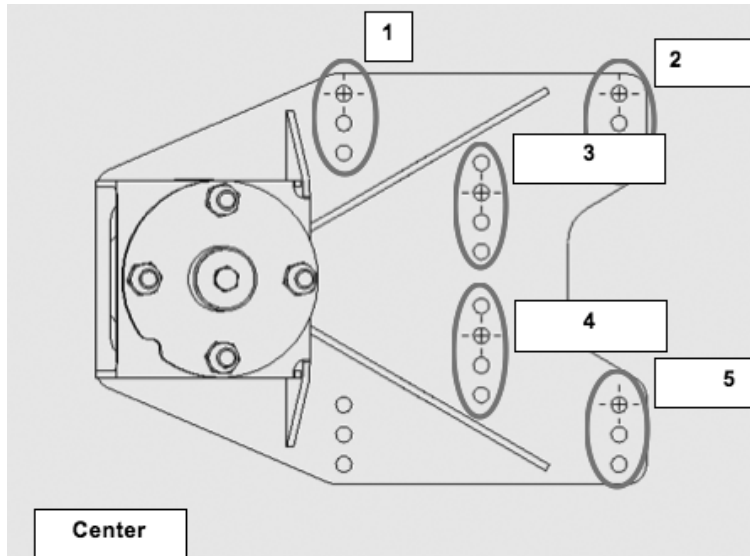

13" Electric Swing Drive

The proximity sensor and mount need to be installed around the swivel plate of the intake head. It replaces the 6" x 2" (152 x 50 mm) plate on the hopper side and auger side of the swivel ring.

Install the proximity rails onto the tabs on the swivel ring. Both rails are identical. Place the rails so that the square ends nearly touch. Use 5/16" x 3/4" (8 x 19 mm) carriage bolts with 5/16" (19 mm) lock nuts to secure the rails on top of the tabs. ***Note: When switching the hopper from one side of the auger to the other, unplug the proximity sensor and switch it with the swivel plate on the other side of the drive section. Remember to readjust the proximity indicators as well.**

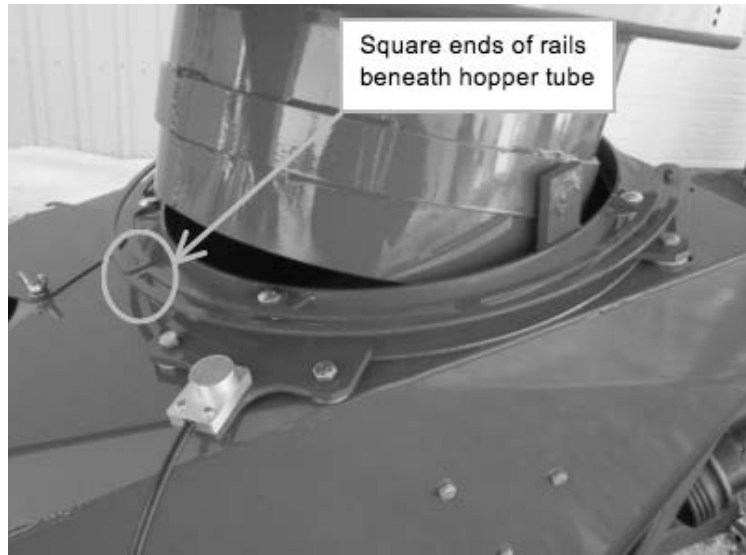

Secure the proximity indicators to the bottom of the rails using 5/16" x 3/4" (8 x 19 mm) carriage bolts with 5/16" (8 mm) wing nuts and 5/16" (8 mm) flat washers.

Install the control box mount by placing it on top of the swing hopper tube. The work light needs to be facing the hopper. Secure the bottom half clamp onto the upper half clamp using the 3/8" x 1-1/4" (10 x 32 mm) bolts and 3/8" (10 mm) lock nuts. Do not fully tighten the half clamp onto the tube as the mount will need to be adjusted to remove the slack from the electric motor harness.

Route the motor cords down towards the hopper. The split in the cord should occur just above the throat of the hopper. Route each end of the cable to the side of the throat and connect it to the plug on each motor cable. The control box can now be moved to help take the slack out of the motor harness.

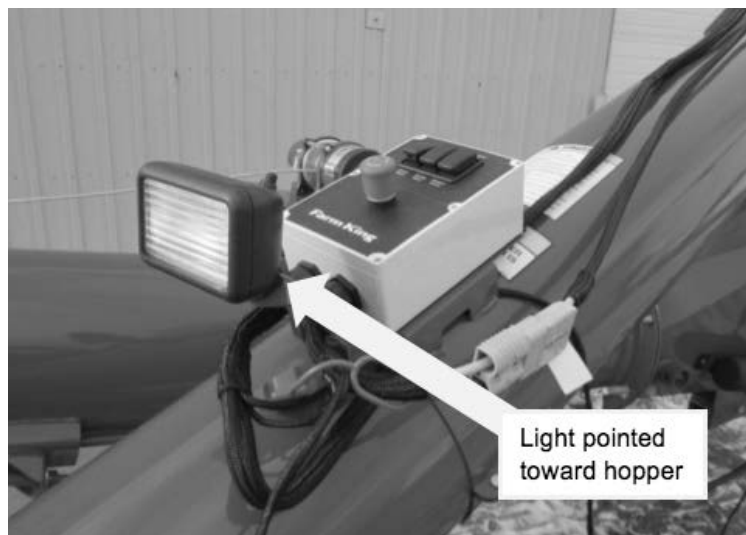

The main power cord has a large red connector that plugs into the control box, and the winch power cord has a large gray connector that plugs into the control box. Plug both of the cords into their respective color-coded connectors on the control box. Route the cords over the intake head. Feed the cords through the handle on top of the intake head. The proximity sensor cord has a small squared gray connector that plugs into a matching connector which comes out of the main power harness on the control box. Connect the proximity sensor cords. Bundle up the slack in the proximity sensor cord at the drop spout until there is enough slack for the hopper to swing out completely and use a cable tie to hold the slack next to the spout.



13" Electric Winch

Mount the electric winch to the auger. Place the mount on top of the main auger tube at approximately 7-1/2' (2.3 m) below the hopper lift arm. The winch should be mounted so that the cable will be spooled on and off from the bottom side of the winch drum as shown in the image below. The winch needs to be level side-to-side.

Secure the bottom half clamp to the upper clamp using six 3/8" x 1-1/4" (10 x 32 mm) bolts with 3/8" (10 mm) lock nuts. Be sure bolts are properly torqued.



Feed the open end of the cable through the pulley on the top end of the hopper lift arm. Route the cable down through the pulley at the base of the lift arm. Feed the cable through the narrow end of the hole in the winch spool. Loop the end of the cable back around towards the center of the spool and into the wide end of the hole. The lifting portion of line needs to be closest to the spool wall. The end of the cable should stop at the small opening of the hole, and should remain visible as the cable is tightened. Hold the wedge provided with the winch inside the loop and pull the lifting portion of the cable (long end) back through the hole. The loop should fit into the wide end of the hole, with the wedge remaining inside the loop.



The winch harness has a red wire and a yellow wire with wire eyelets at its free end. Route the red and yellow wires from the drive section to the winch. Connect the red wire of the winch harness to the blue terminal on the winch. Connect the yellow wire to the yellow terminal on the winch.

Mount the shield over the winch with the winch cable reeling in and out of the middle cutout in the shield as shown in the image below. Route the harness out of the open space in the bottom of the winch shield on the same side as the power terminals on the winch as shown below. Secure the shield using four 3/8" x 1" (10 x 25 mm) bolts and 3/8" (10mm) lock nuts.

Connect the main power harness eyelets to the battery terminals, with the red wire connecting to the positive terminal and the black wire connecting to the negative terminal.

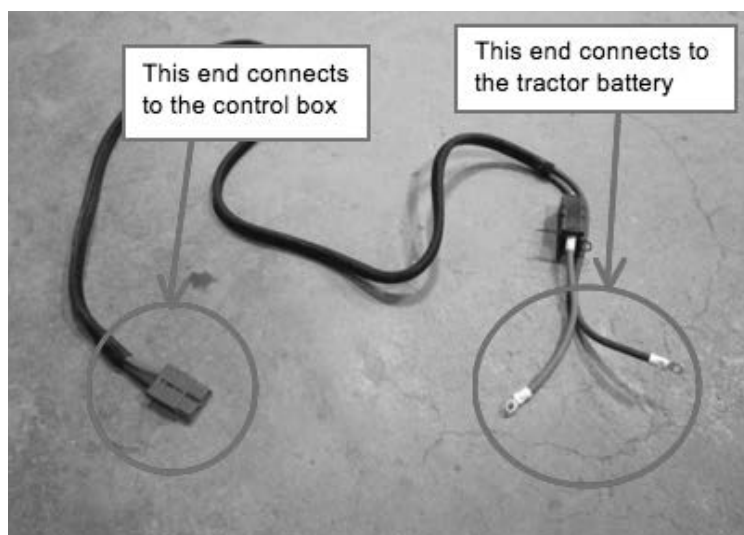

Disengage the safety stop on the control box and carefully begin to wind the cable onto the winch until the cable is tight. The cable should be spooling in and out from the bottom of the winch.

Use plastic cable ties to secure the harnesses at other locations where necessary. Leave enough slack in the cable to keep it from getting pulled tight when hopper swings to full limits



Remote & Transmitter

Recharging

Plug the charging connector into the port at the top of the transmitter (remote control). Observe orientation and do not use force. A solid red LED indicates battery is charging. Once the internal battery is fully charged, the red LED will turn off and the green LED will turn on. A fully discharged unit will take up to 3 hours to recharge.

Indicator lights

The transmitter has two LED indicators: the red BATTERY/DIAGNOSTIC indicator and the green TRANSMIT indicator. The green TRANSMIT indicator flashes rapidly whenever there is communication between the transmitter and the receiver. The red BATTERY/DIAGNOSTIC indicator starts blinking once every second when the battery voltage is low and requires charging. Refer to the ERROR CODE CHART for the definitions of the codes.

Transmitter Error Code Chart

Error Code	Probable Cause
1	Low Battery

Note: The red LED will stay on while charging and when the charge is completed the green LED will stay on.

Note: It will take longer to charge if the transmitter is on during operation.

Teach ID Code

To synchronize a new transmitter and receiver together, use the following procedure:

1. Make sure both the transmitter and the receiver are off.
2. To get the transmitter into TEACH ID mode, press and hold the POWER button until both lights start to blink. Release the POWER button.
3. Apply power to the receiver.
4. Wait for 1 second or until the green and red LEDs on the transmitter stop blinking and the green LED starts blinking rapidly on the transmitter.
5. TEACH mode is complete.

Cloning Transmitters

To clone a new transmitter to work with an existing receiver and transmitter, use the following procedure:

1. On transmitter A (the master):
 - a. Press the POWER button for more than 10 seconds.
 - b. At this point, both LEDs will blink. Release the POWER button.
2. On transmitter B (the clone):
 - a. Press the POWER button, LEFT button, and RIGHT button simultaneously.
 - b. At this point, both LEDs will blink. Release all buttons.
3. Wait for 1 second or until the green and red LEDs stop blinking on both units.
4. Turn both transmitters off.
5. Synchronize one of the transmitters to the receiver using the TEACH ID CODE instructions. Synchronization must be done anytime a clone is made.

Warning: Cloning multiple transmitters can pose a safety risk. Hopper may move without notice if another transmitter is unintentionally activated. To reduce risk turn transmitter off when not in use.

Indicator & Clip Bracket

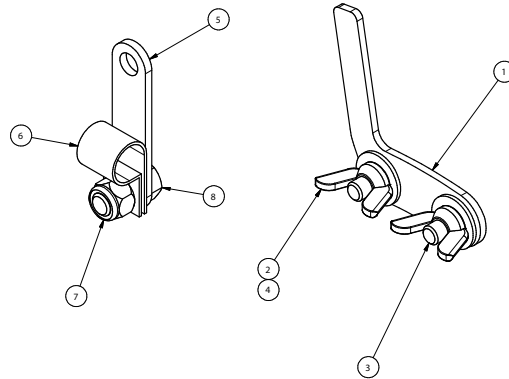

Part #	Item #	Description	Qty
1	SZ000968	Proximity Indicator	1
2	SZ125040	Nut Wing, 5/16-18Unc	2
3	SZ126006	Bolt Carriage 5/16-18 Unc 3/4"	2
4	SZ127001	5/16" Flat Washer	2
5	SZ001130	P-Clamp Bracket	1
6	SZ000566	5/16" P-Clamp	1
7	SZ125030	Nut Lock 3/8" - 16 Unc Nylock	1
8	SZ126063	Blt Hhcs 3/8" - 16 Unc x 3/4" G5	1

13" Electric Motor Mount Assembly

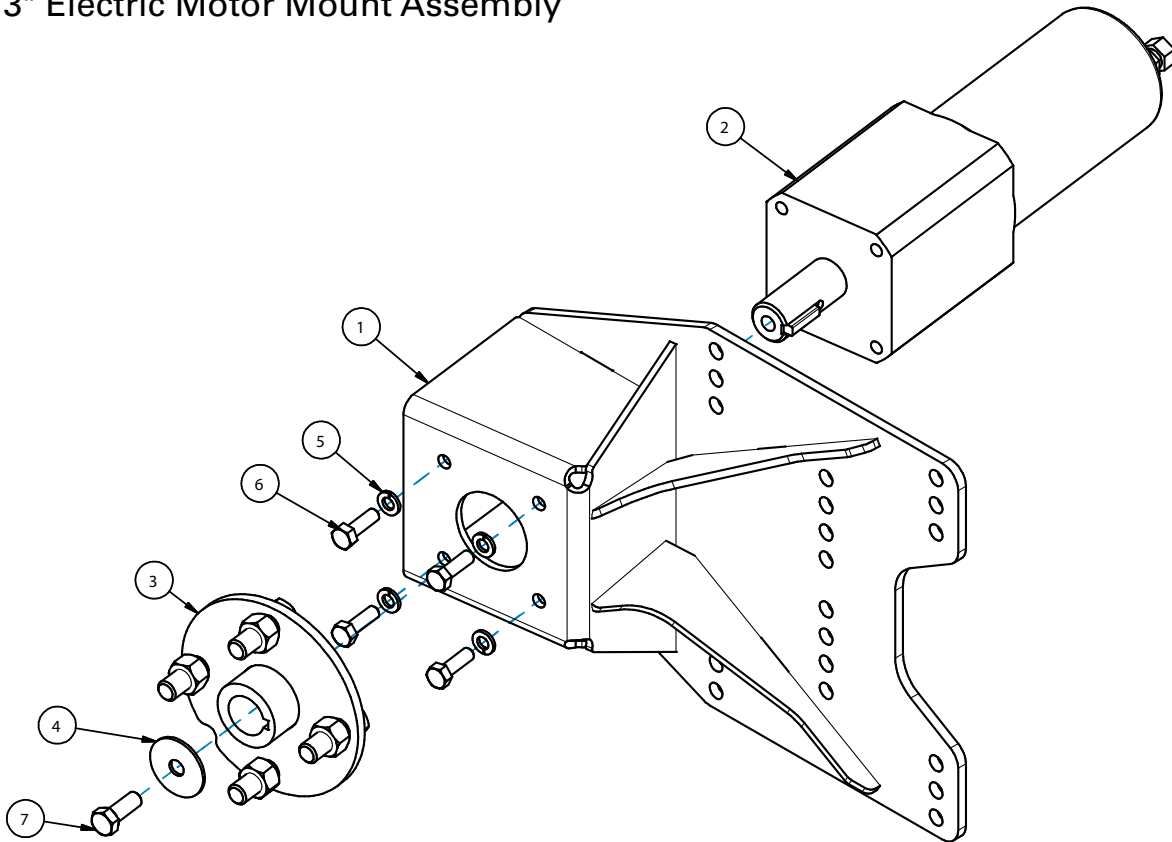

Part #	Item #	Description	Qty
1	SZ000898	10/13" Elect Mtr Mnt Wldmt	1
2	SZ000892	Motor For Elec Hppr Mvr	1
3	SZ000895	Elect Hppr Mvr Wheel Hub	1
4	SZ000906	.406" Id x 1.50" Od 14 Ga Wshr	1
5	SZ127010	Wshr Lck, 5/16"	4
6	SZ126047	Blt Hhcs, 5/16" - 18Unc, 1" G5	4
7	SZ126065	Blt Hhcs 3/8" - 16 Unc 1" G5	1

13" Electric Mover / Winch Combo Kit

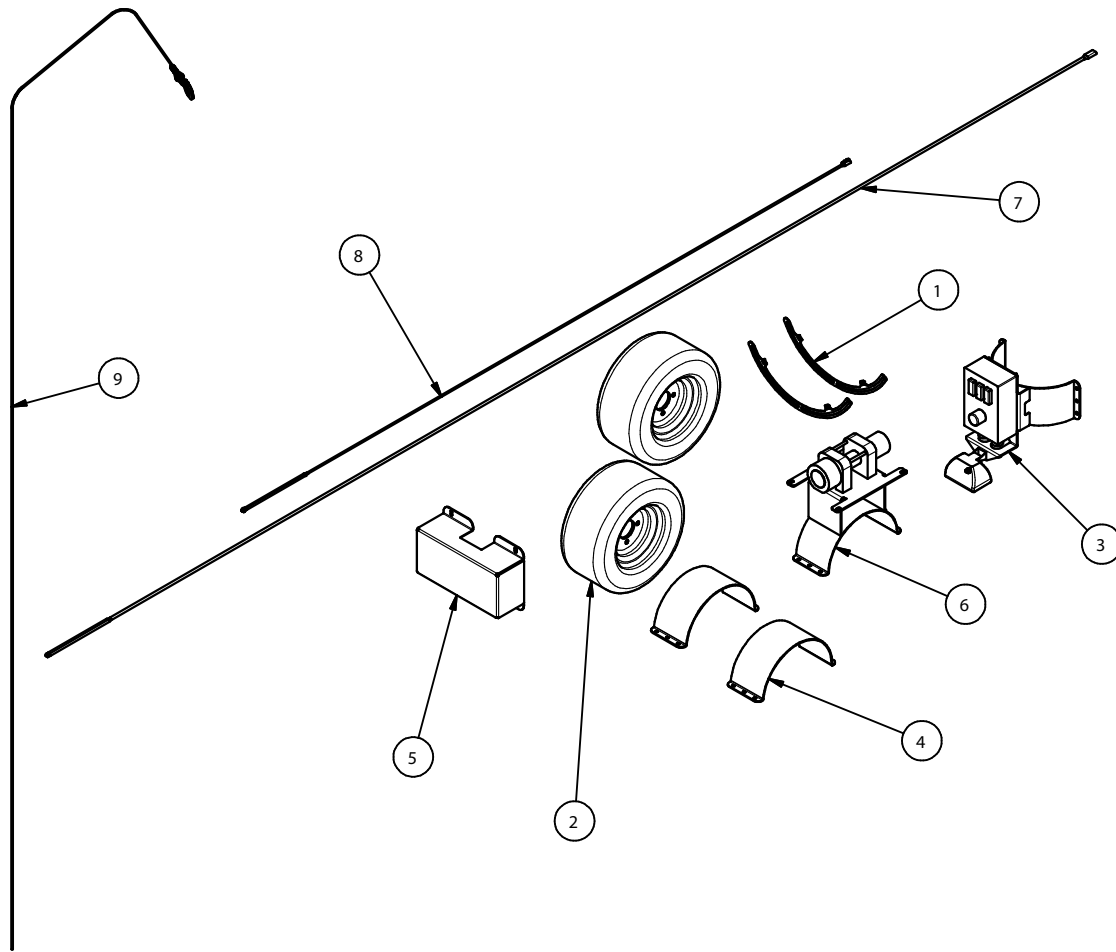

Part #	Item #	Description	Qty
1	SZ000956	13" Mrd Proximity Rail	2
2	SZ101503-6	Tire & Wheel Assy w/ Valve Stem	2
3	SZ001042	13" Ctrl Box Mount Assembly	1
4	SZ000780	13" 3-Bolt Half Clamp	2
5	SZ000981	Elec Winch Shield	1
6	SZ001053	13" Elec Winch Mnt Asmby	1
7	SZ000999	Winch Harness	1
8	SZ000998	Harness, Elec Mvr, Winch	1
9	SZ0213235	Assy Cable 3/16" 480 Grabhook	1

13" Prox Sensor Mount Assembly

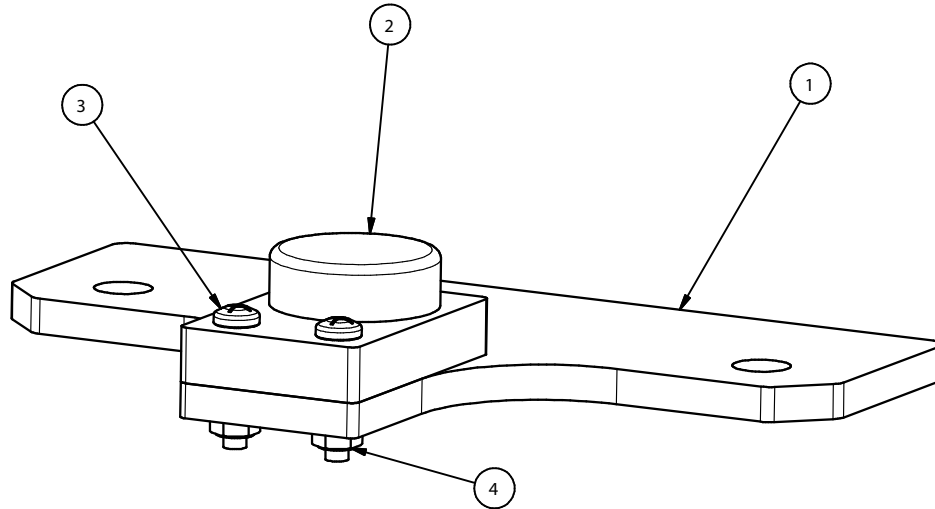

Part #	Item #	Description	Qty
1	SZ000959	13/16" Proximity Mnt	1
2	SZ001000	Prox Switch w/ Connector	1
3	SZ001021	Screw Mach #8-32 x 0.875 Panhd	2
4	812537	Nut Lock (Nylon) 0.136 Nc Grb PI	2

13" Control Box Mount Assembly

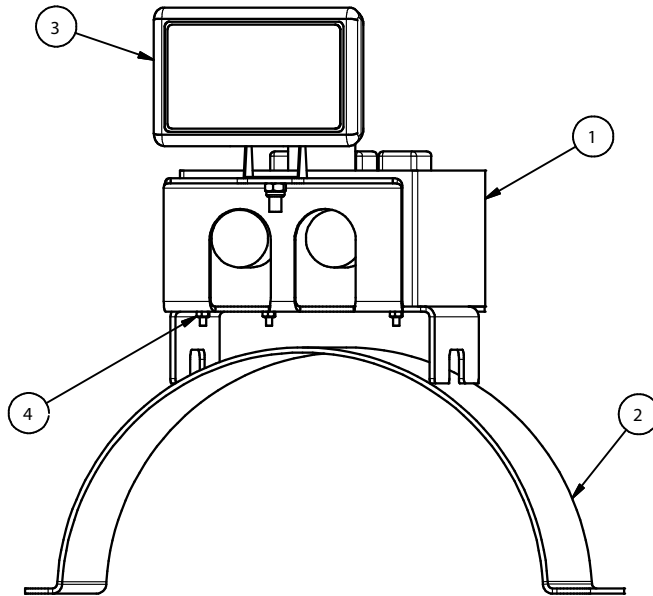

Part #	Item #	Description	Qty
1	SZ000997	Electric Control Box, Winch	1
2	SZ000992	13" Electric Control Box Mount	1
3	86038018	Worklight - Push Button Switch	1
4	812537	Nut Lock (Nylon) 0.136 Nc Grb Pl	4

13" Electric Winch Mount Assembly

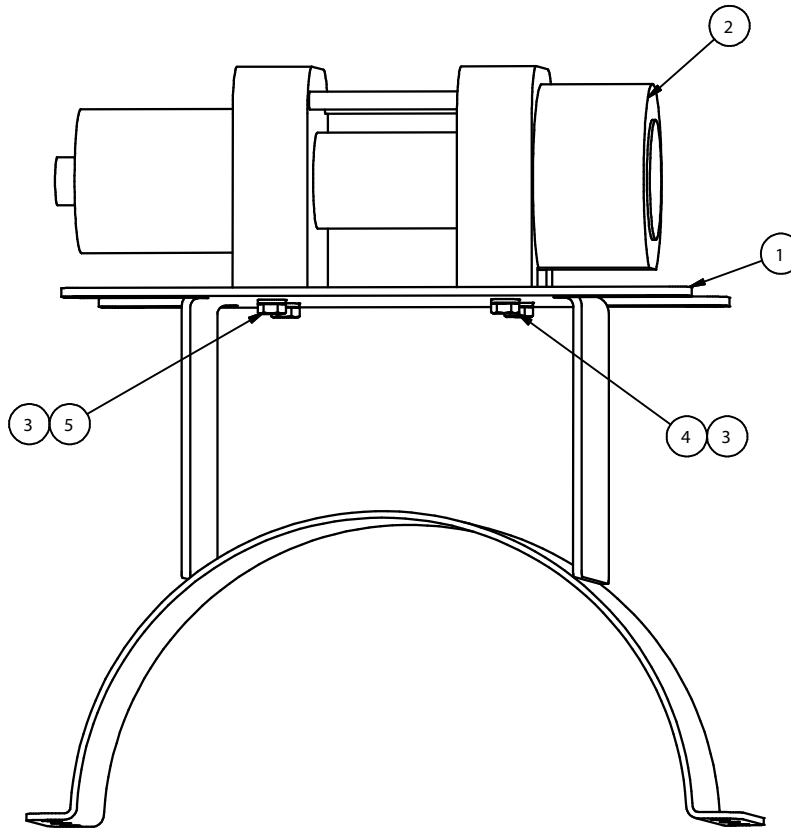

Part #	Item #	Description	Qty
1	SZ000978	13" Elec Winch Mnt	1
2	SZ000987	Warn Dc800 Elec Hoist	1
3	-	M8 Lock Washer	4
4	-	Bolt M8 x 20 mm	2
5	-	Bolt M8 x 25 mm	2

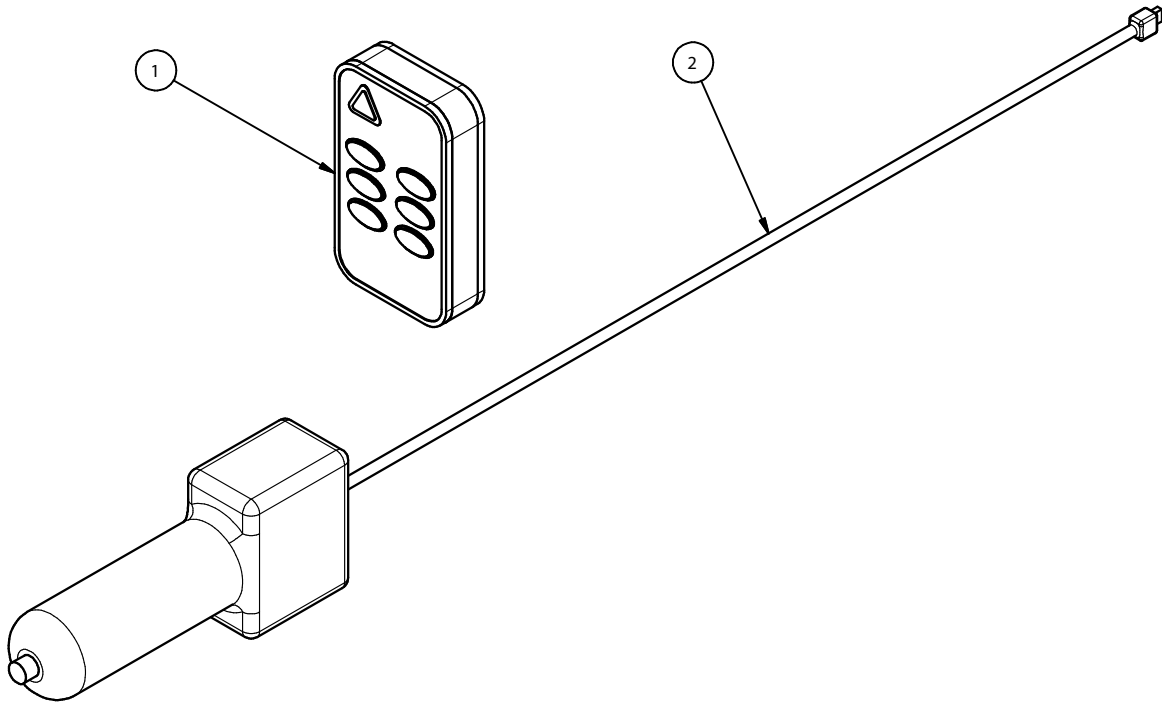
13" Electric Swing Remote & Charger

Part #	Item #	Description	Qty
1	SZ001002	Remote Control, 7-Button	1
2	SZ000921	12V Remote Charger	1

www.farm-king.com

Farm King

1330 43rd Street NW
Fargo, North Dakota USA 58102
Ph.: 701.282.7014 | Fax: 701.282.5865
E-mail: info@buhler.com
www.farm-king.com

Equipment shown is subject to change without notice.
©2014 BuhlerTrading Inc. Printed in USA. TSX:BUI

bühler | *a division of Buhler Industries Inc.*