



ENGINE MOUNTING KIT PH CLUTCH PUMP

Mounting kit has bolt pattern specially designed for Muncie PH Clutch Pumps.

MOUNTING KITS INCLUDE ALL HARDWARE, PULLEYS AND BELTS AS REQUIRED.

ENGINE MOUNTING KITS FOR PH PUMPS: Mounting kits are designed for vehicles with or without air conditioning unless noted otherwise.

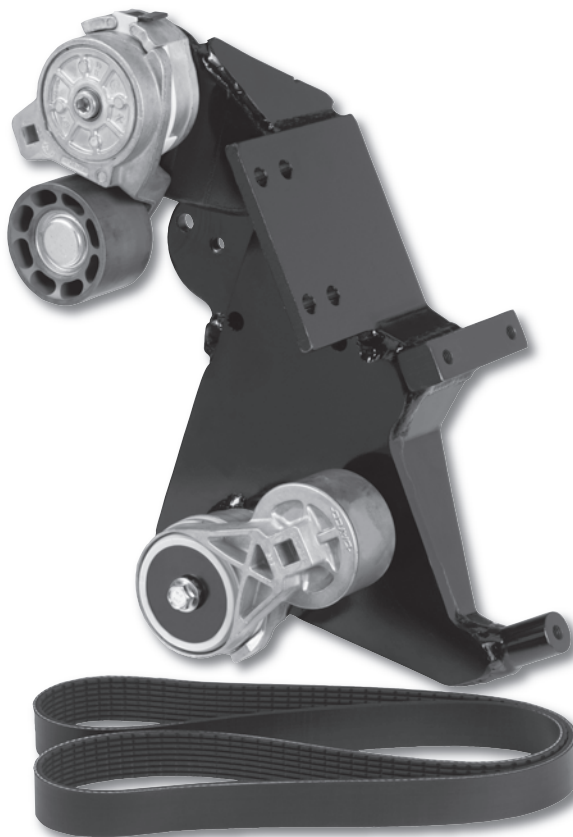

(See MP89-14 for Clutch Pumps)

MODEL NUMBER CONSTRUCTION — PH CLUTCH PUMP ENGINE MOUNTING KIT

CMK F 08 - 6400 - P8 - AC

Series C

Mounting Kit Type

MK — Pickup & Medium Duty Truck
VK — Passenger Van

Chassis Mfg.

C — Chev./GMC I — Isuzu
D — Dodge M — Mercedes (Freightliner/Sterling)
E — Mitsubishi N — International (Navistar)
F — Ford P — Peterbilt

Model Year

First year kit designed for engine (assume it fits subsequent year unless newer year kit available).

Engine (Typical - Not All Shown)

Chevrolet/GMC

5360 5.3, 6.0 Liter Gas
6500 6.5 Liter Diesel
6600 6.6 Liter Diesel
8100 8.1 Liter Gas

Dodge

3136 318, 360 cu. in.
360P 360 cu. in.
3600 360 cu. in.
590D 5.9 Liter Diesel
5900 5.9 Liter Diesel

Ford

5400 5.4 Liter Gas
5900 5.9 Liter Diesel
6000 6.0 Liter Diesel
6800 6.8 Liter Gas

6910 6.9L, 7.3L Diesel
7300 7.3 Liter Diesel

International (Navistar)

3600 DT360 Diesel
4046 DT408, DT466 Diesel
444E 7.3 Liter Diesel
4600 DT466 Diesel

Isuzu / Chevy / GMC

3500 350 cu. in.
4700 4.7 Liter Gas
5700 5.7 Liter Gas

Mercedes Group

3126 Caterpillar Diesel
5900 5.9 Liter Diesel

Kit Style

AC — Kits designed to work with trucks with air conditioners. (Delete if applicable.)
X — Bracket Kit Only. Inline to OEM Belts.

Drive Option (Omit for Single Belt Kits)

A — Dual 1/2" V-Belt Kits
AH — Dual 1/2" V-Belt Kits, with longer belts for heavy duty clutch
AW — Dual 1/2" V-Belt Kit, with water pump
P6 — Serpentine 6 Groove Poly V-Belt*
P8 — Serpentine 8 Groove Poly V-Belt*
P8W — Serp. 8 Gr. Poly V-Belt, w/water pump*
XP6 — Serp. 6 Gr. Poly V-Belt, Bracket kit only*
XP8 — Serp. 8 Gr. Poly V-Belt, Bracket kit only*
LA — Dual 1/2" V-Belt Kit, Ford Compliant Crank Pulley
LP8 — Serpentine 8 Groove Poly V-Belt, Ford Compliant Crank Pulley*

*Requires matching 6 or 8 groove clutch



**Muncie®
Power
Products**

Muncie Power Products, Inc. Member of the Interpump Hydraulics Group
General Offices and Distribution Center • P.O. Box 548 • Muncie, IN 47308-0548
(765) 284-7721 • FAX (765) 284-6991 • E-mail info@munciepower.com
Web site <http://www.munciepower.com>



LITER	TYPE	DRIVE (ENG%)	YEAR	CHASSIS	KIT MODEL NO.	COMMENTS
CHEVROLET/GM						
4.8, 5.3, 6.0	Gas	I6 (1.25)	1999 - '10	Silverado	CMKC99-5360-XP6-AC	8HP Limit, In-Line Bracket Kit Only, 118A, 130A, 145A Alt.
4.8, 5.3, 6.0	Gas	I6 (1.25)	2011 - Current	Silverado	CMKC11-5360-XP6-AC	8HP Limit, In-Line Bracket Kit Only, 118A, 130A, 145A Alt.
5.0, 5.7	Gas	A2 (108)	1996 - '00	C&K 1500-3500 & Van	CMKC96-5057-A-AC	96-'00 Trucks, '97-'02 Vans, w/w Dual Battery
5.0, 5.7	Gas	A8 (118)	1996 - '00	C&K 1500-3500 & Van	CMKC96-5057-P8-AC	96-'00 Trucks, '97-'02 Vans, w/w Dual Battery
5.3, 6.0	Gas	I6 (108)	2003 - '10	G1500-3500 Van	CVKC03-5360-XP6-AC	W/o EGR Valve
6.0, 7.0	Gas	A2 (108)	1990 1/2-'98	C60, C70	CMKC90-3642-A	W/o AC
6.5	Dsl	A2 (108)	1996 - '02	C&K 1500-3500, HD	CMKC96-6500-A-AC	W/o Dual Alt., H.D. Clutch NA, Old Style Body Only
6.6	Dsl	A2 (108)	1990 - '98	C60, C70	CMKC91-3116-A	Cat 3116 w/o AC
6.6	Dsl	A8 (118)	2003 - '04 1/2	C4500, 5500	CMKC03-660M-P8-AC	LLY Emission Code (1-04 and Later), w/w Dual Alt., w/w AC
6.6	Dsl	A8 (118)	2004 - '07 1/2	C4500, 5500	CMKC06-660M-P8-AC	LLY Emission Code (1-04 and Later)
6.6	Dsl	A8 (118)	2007 1/2 - '10	C4500, 5500	CMKC07-660M-P8-AC	W/w Dual Alternators
6.6	Dsl	I6 (108)	2001 - '10	2500HD, 3500, HD	CMKC06-6600-XP6-AC	8HP Limit, In-Line Bracket Kit Only, w/o Dual Alt., Max 1.55 cu.in. Pump Due To Interference
6.6	Dsl	I6 (108)	2011 - Current	2500HD, 3500, HD	CMKC11-6600-XP6-AC	8HP Limit, In-Line Bracket Kit Only, w/o Dual Alt., Max 1.55 cu.in. Pump Due To Interference
7.2	Dsl	A2 (108)	1999 - '03	C60, 65, 70, 75 Kodiak, Topkick	CMKC99-3126-A-AC	W/w AC, w/w Air Brakes, Not for Low Profile
7.2	Dsl	I8 (137)	2004 - '07 1/2	C6500, 7500 Kodiak, Topkick	CMKC04-3126-XP8-AC	10HP Limit, Cat 3126, w/ AC Only, w/w Air Brakes
7.2	Dsl	A2 (108)	1990 - '02	C6500, 7500 Kodiak, Topkick	CMKC02-3126-A-AC	Cat 3126, 3116, w/w AC, w/w Air Compressor, Not for Low-Pro
7.4	Gas	A2 (108)	1996 - '00	C&K 1500-3500, HD	CMKC96-7400-A-AC	W/o Dual Alt., w/o K19 CA Emissions, Without A.I.R.
7.4	Gas	A2 (108)	1999 - '00	C60, C70 Med. Duty	CMKC99-740M-A-AC	W/o Air Brakes, w/ Power Steering Mounted Low
7.8	Dsl	A8 (137)	2004 - '10	C6500, 7500	CMKC04-7800-P8-AC	W/w AC, W/w Air Brakes
8.1	Gas	A8 (118)	2001 - '08	2500HD, 3500 (Not HD)	CMKC01-8100-P8-AC	8 Groove Pulley, With Driver Side Alt.
8.1	Gas	A8 (118)	2001 - '10	2500HD, 3500, HD, 4500 - 5500	CMKC01-81CK-P8-AC	Passenger Side Alt., '02-3500HD, '03-'10-4500, 5500
8.1	Gas	A8 (118)	2001 - '10	C6500, 7500	CMKC01-810M-P8-AC	W/w Air Brakes, w/w Air Compressor, w/w AC
DODGE						
5.2, 5.9	Gas	A2 (108)	1993 - '01	3/4 Ton	CMKD94-3136-A-AC	318, 360 cu.in., '93-'99 360, '92-'01 318, Will not fit '00 318, w/o A.I.R."
5.7	Gas	A8 (118)	2003 - '08	D2500-3500	CMKD03-5700-P8-AC	5.7 Hemi, 10HP Limit, w/ AC Only "
5.7	Gas	A6 (108)	2009 - '10	D2500-3500	CMKD09-5700-P8-AC	W/w Air Conditioning
5.9	Gas	A2 (108)	1993 - '99	1 Ton	CMKD94-3600-A-AC	W/ A.I.R.
5.9	Dsl	A2 (108)	1994 - '98	D250-350	CMKD94-5900-A-AC	W/ Intercooler
5.9	Dsl	A2 (108)	1998 1/2 - '02	D250-350	CMKD98-5900-A-AC	ISB Diesel (24 valve)
5.9	Dsl	A8 (118)	1998 1/2 - '02	D250-350	CMKD98-5900-P8-AC	ISB Diesel (24 valve), With 8 Groove Pulley"
5.9	Gas	A2 (108)	2000 - '02	1 Ton	CMKD00-3600-A-AC	New OEM Pulley w/ modifications, w/ A.I.R. "
5.9	Gas	A2 (108)	2000 - '02	3/4 Ton	CMKD00-36LA-A-AC	New OEM Pulley w/ modifications, w/w A.I.R. "
5.9	Dsl	A6 (108)	2003 - '07 1/2	R250-350	CMKD04-5900-P6-AC	ISB Diesel (24 valve), With AC Only
6.7	Dsl	I8 (137)	2007 1/2 - '10	3500 - 5500	CMKD08-6700-XP8-AC	3500 - 5500, 10 HP Limit
6.7	Dsl	I8 (137)	2011 - Current	3500 - 5500	CMKD11-6700-XP8-AC	W/ Air Conditioning, 10 HP Limit, Bracket Kit Only
8.0	Gas	A1 (108)	1994 - '02	Truck	CMKD94-8000-AC	5HP Limit Due To Harmonic Balancer
FORD						
4.9	Gas	A2 (108)	1990 - '96		CMKF93-3000-A-AC	300 cu.in. 6 cyl., Special side port pump req.
5.0, 5.8	Gas	A2 (108)	1988 - '97		CMKF90-3035-A-AC	302, 351W cu.in.
5.4	Gas	A2 (108)	1997 - '03	F150-250, '04 Classic	CMKF97-5400-AW-AC	Ford Compliant Crank Pulley + Ford Water Pump
5.4	Gas	A2 (108)	1999 - '04	F250-550 SD	CMKF00-5400-AW-AC	Ford Compliant Crank Pulley + Ford Water Pump
5.4	Gas	A8 (118)	1999 - '04	F250-550 SD	CMKF00-5400-P8W-AC	Ford Compliant Crank Pulley + Ford Water Pump, Requires 8 Groove Clutch
5.4, 6.8	Gas	A2 (108)	2005 - '11	F250-550 SD	CMKF05-5468-LA-AC*	3-Valve Eng., 18 HP Limit, Ford Compliant Spider Bracket Pulley
5.4, 6.8	Gas	A8 (118)	2005 - '11	F250-550 SD	CMKF05-5468-LP8-AC*	3-Valve Eng., 18 HP Limit, Ford Compliant Spider Bracket Pulley, Requires 8 Groove Clutch
5.4, 6.8	Gas	A2 (108)	1997 - '99	Van	CVFK98-5468-A-AC	Ford Compliant Crank Pulley, 5 HP Limit
5.4	Gas	A2 (108)	1997 - '03	Van	CVFK00-5400-AW-AC	Ford Compliant Crank Pulley + Ford Water Pump
5.4	Gas	A8 (118)	1997 - '03	Van	CVFK00-5400-P8W-AC	Ford Compliant Crank Pulley + Ford Water Pump, Requires 8 Groove Clutch
5.9	Dsl	A2 (108)	1993 - '98	Not for L Series Chassis	CMKF93-5900-A-AC	W/o Large Radiator Tank
5.9	Dsl	A2 (108)	1995 - '98	Not for L Series Chassis	CMKF95-5900-A	W/o Air Conditioning
5.9	Dsl	A2 (108)	1999	F600-700	CMKF99-5900-A-AC	W/w Air Conditioning, w/w Air Brakes
5.9	Dsl	A2 (108)	2000 - '03	F650-750	CMKF00-5900-A-AC	ISB (24 valve)
6.0, 7.0	Gas	A2 (108)	1985 1/2 - '99		CMKF97-3742-A	370, 429 cu.in., w/o Air Conditioning
6.0	Dsl	A8 (118)	2003 - '07 1/2	F250-550 SD	CMKF03-600A-P8-AC	W/o Dual Alternators, Requires 8 Groove Clutch, Aluminum Bracket
6.0	Dsl	A8 (118)	2003 - '07 1/2	F650-750	CMKN03-3650-P8-AC	W/o Air Brakes
6.2	Gas	I8 (118)	2011 - Current	F250-350 SD	CMKF11-6200-P8-AC	W/w AC, W/w HD Alt.
6.4	Dsl	I8 (137)	2007 1/2 - '10	F250-550 SD	CMKF08-6400-P8-AC	W/o Dual Alt.
6.4	Dsl	I8 (137)	2007 1/2 - '10	F250-550 SD	CMKF08-6401-P8-AC	W/ Dual Alt.
6.7	Dsl	I8 (135)	2011 - Current	F250-550 SD	CMKF11-6700-P8-AC	W/w AC, With Single Alt. & Single Alt. Water Pump Only, Pump must use side ports w/ 45 deg. fittings. Max. pump size 2.17 cu.in. (PH9).
6.8	Gas	A2 (108)	1999 - '04	F250-550 SD	CMKF00-6800-A-AC	Ford Compliant Crank Pulley
6.8	Gas	A8 (118)	1999 - '04	F250-550 SD	CMKF00-6800-P8-AC	Ford Compliant Crank Pulley, Requires 8 Groove Clutch
6.8	Gas	A2 (108)	1997 - '03	Van	CVFK00-6800-A-AC	Ford Compliant Crank Pulley
6.8	Gas	A8 (118)	1997 - '03	Van	CVFK00-6800-P8-AC	Ford Compliant Crank Pulley, Requires 8 Groove Clutch
7.2	Dsl	A2 (108)	2000 - '01	F650-750	CMKF00-3126-A-AC	Caterpillar 3126B (Eng. Ser. No. 8YL82468 & Lower)
7.2	Dsl	A2 (108)	2001 - '03	F650-750	CMKF01-3126-A	Cat 3126B w/o AC, w/ 2 Bolt Alt., Eng. S/N 8Y82469 & Higher
7.2	Dsl	A2 (108)	2001 - '03	F650-750	CMKF01-3126-A-AC	Cat 3126B w/ AC, w/ 2 Bolt Alt., Eng. S/N 8Y82469 & Higher
7.2	Dsl	A2 (108)	2004 - '07 1/2	F650-750	CMKF04-3126-P8-AC	Cat 3126 C7, w/o Air Brakes, w/ 4 Bolt Alt., Requires 8 Groove Clutch
7.3	Dsl	A2 (108)	1994 1/2 - '97		CMKF95-73DI-A-AC	1st Year Direct Injection
7.3	Dsl	A2 (108)	1999 - '03	F250-550 SD	CMKF99-7300-A-AC	H.D. Clutch Not Available
7.3	Dsl	A8 (118)	1999 - '03	F250-550 SD	CMKF99-7300-P8-AC	Requires 8 Groove Clutch
7.3	Dsl	A2 (108)	2000 - '03	F650-750	CMKF00-730M-A-AC	W/o Air Brakes Only
8.3	Dsl	A2 (108)	1993 - '98	L8000 Only	CMKF93-830L-A	W/o Air Conditioning
8.3	Dsl	A2 (108)	1993 - '99	F800	CMKF93-8300-A	W/o Air Conditioning
ISUZU						
5.2	Dsl	A8 (118)	2011 - Current	NPR, 3500, 4500	CMKI11-5200-P8-AC	
5.7	Gas	A2 (108)	1996 - '03	NPR, 3500, 4500	CMKI96-5700-A-AC	
MERCEDES GROUP (FREIGHTLINER & STERLING)						
7.2	Dsl	A2 (108)	2000 - '03	FL60, FL70, Sterling Acterra	CMKM00-3126-A-AC	Cat. 3126 w/o Fan Air Clutch
7.2	Dsl	I8 (137)	2000 - '03	FL60, FL70, Sterling Acterra	CMKM00-3126-XP8-AC	Cat. 3126 (bracket kit only), w/w Fan Air Clutch
7.2	Dsl	I8 (137)	2004 - '07 1/2	Sterling Acterra	CMKM04-312S-P8-AC	Cat 3126 W/w Air Brakes, w/o fuel filter mounted on engine front @ 1:00 position, w/o Fan Air Clutch
MITSUBISHI						
4.9	Dsl	A2 (108)	2000 - '03	FE - FG, 4M50	CMKE00-4900-A-AC	Will not fit '04 with 5/8 Groove OEM Pulley
4.9	Dsl	A2 (108)	2002 - '11	FE - FG, 4M50	CMKE02-4900-P6-AC	W/w Air Conditioning
INTERNATIONAL (NAVISTAR)						
4.7, 5.96	Dsl	A8 (118)	2003 - '07 1/2	4200	CMKN03-3650-P8-AC	VT275, VT365
6.4	Dsl	A8 (118)	2007 - '09	4200	CMKN08-6400-P8-AC	VT389, MaxForce 7, w/w Air Conditioning, w/o Air Compressor
6.7, 7.6	Dsl	A2 (108)	1994 - '02		CMKN94-4064-A	DT408, DT466, w/o Air Conditioning
7.3	Dsl	A2 (108)	1994 - '02		CMKN94-444E-A-AC	T444E, w/o Air Brakes, Will not fit LP, LPX Chassis
7.6, 8.7	Dsl	I8 (137)	2002 - '04	4300, 4400	CMKN02-4600-XP8-AC	DT466, DT530, Bracket Kit Only, 10 HP Limit, w/o 275 Amp Alt.
7.6, 8.7	Dsl	I8 (137)	2002 - '04	7300 - 7400	CMKN02-53XX-XP8-AC	DT466, DT530, Bracket Kit Only, 10 HP Limit, w/o 275 Amp Alt., Installer supplies belt
7.6	Dsl	A8 (118)	2007 1/2 - '10	4300, 4400	CMKN08-460M-P8-AC	DT466 MaxForceDT 245 & 255 HP Only, w/o Fan Air Clutch
7.6	Dsl	A8 (118)	2007 1/2 - '10	4300, 4400	CMKN08-460H-P8-AC	DT466 MaxForceDT Up to 260 HP, w/w Air Brakes, w/ Fan Air Clutch
PETERBUILT						
7.2	Dsl	A8 (118)	2003 - '07 1/2	330	CMKP03-3126-P8-AC	Cat 3126

*Automatic "Vacuum Shift" 4 wheel drive - Requires bracket No.: FMB474A (Sold Separately).

- Drive category indicates the type of clutch to be used, 2, 6 or 8 groove pulley, engine %, and how it's driven: **I** = inline to OEM belts **A** = add on pulley
- The final pump speed (engine %) is determined by the pulley drive ratio between the OEM Crankshaft pulley diameter & the clutch pump pulley diameter.