

FR3C SERIES

POWER TAKE-OFF FOR THE FORD TORQSHIFT®



THE PROVEN LEADER IN DURABILITY

Muncie Power's FR3C power take-off gives you the maximum torque available from the F-650 and F-750 with the Ford Torqshift transmission and a keyed shaft output. Our PTO utilizes a one-piece housing design with forced lubrication for increased durability and simplified installation. The FR3C incorporates patented noise suppression technology, integral mobile or stationary functions and a higher torque capacity of 237 lbs.ft.



KEY FEATURES

- Using patented technology
- Utilizes maximum torque available from Ford Torqshift transmission
- Higher torque capacity of 237 lbs.ft.
- One-piece housing, few leak points
- Complete integrated wiring harnesses
- Keyed shaft output
- Enhanced gear set

DIMENSIONS

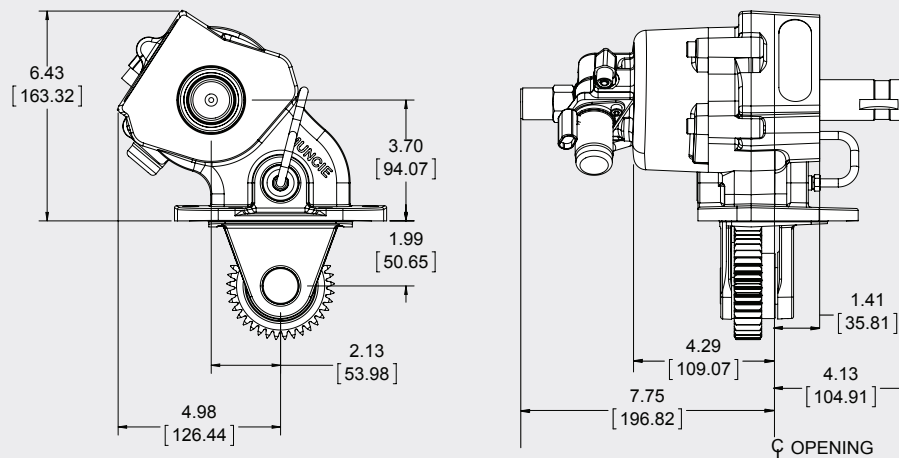

PTO TORQUE & HORSEPOWER RATINGS

SPEED RATIO	INTERMITTENT HP@ 1000 RPM	INTERMITTENT TORQUE LBS.FT.	CONTINUOUS TORQUE LBS.FT.	INTERMITTENT (KW)@ 1000 RPM	INTERMITTENT TORQUE (NM)	CONTINUOUS TORQUE (NM)
09	45	237	166	(34)	(321)	(225)

MODEL NUMBER CONSTRUCTION

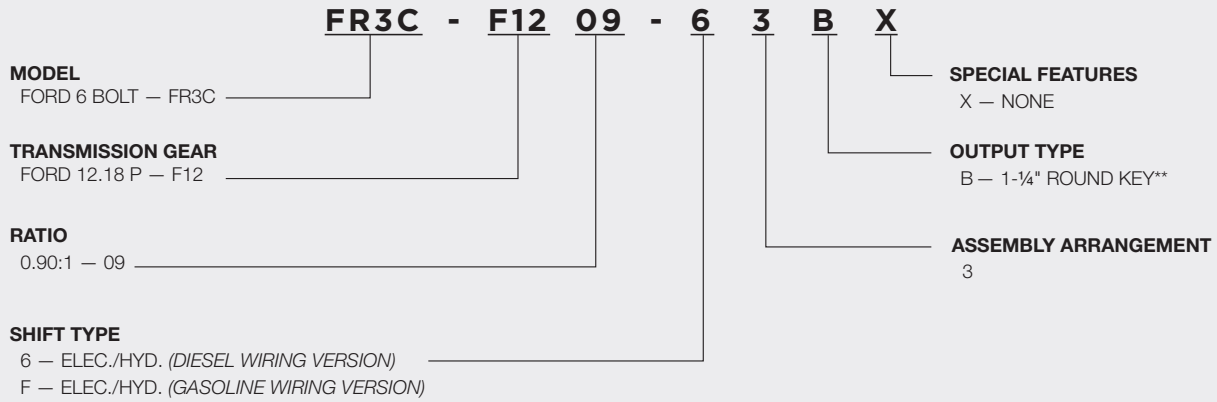

** Driveline output is not recommended on 4x4 Chassis.

