

# OPTIMUM<sup>®</sup> Y SERIES

## GEAR PUMPS



### DESIGNED FOR OPTIMUM PERFORMANCE

The Optimum Y Series gear pumps/motors offer premier performance for a wide variety of applications across several industries. Featuring the innovative OPTI-GRIP technology, the Optimum Y Series exemplifies strength, endurance and rigidity making for long lasting units even in the most extreme conditions. The Y Series has the largest range of the Optimum group, providing 9 displacements to cover high flow, high demand applications.

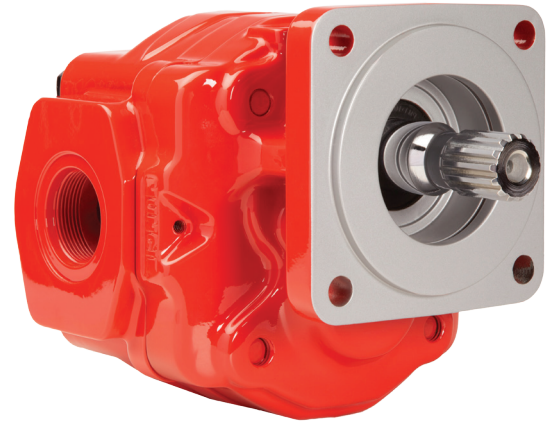

### KEY FEATURES

- 9 pump displacements available
- OPTI-GRIP (patented) design
- Long life, high performance bushings
- Noise reducing, quiet design
- Bi-rotational, 4 port design standard (SAE straight thread only)
- Pressures up to 4,000 PSI (275 bar)
- Speeds up to 3,000 RPM
- High quality, tested design
- Additional features & benefits

### PUMP SPECIFICATIONS

MODEL NUMBER	DISPLACEMENT IN <sup>3</sup> (CC)	MAX* RPM	MIN* RPM	MAX PRES PSI (BAR)	PORTS (ODT) SIDE & REAR	PORTS (SF) SIDE ONLY	WEIGHT LBS (KG)
Y22	5.12 (83)	3,000	1000	4,000 (275)	-24	2.0" X 1.5"	76.9 (34.9)
Y26	6.19 (101)	3,000	800	4,000 (275)	-24	2.5" X 1.5"	79.9(36.3)
Y31	7.16 (117)	2,750	600	4,000 (275)	-24	2.5" X 1.5"	83.2 (37.7)
Y35	8.04 (132)	2,500	600	3,750 (260)	-24	2.5" X 1.5"	85.5 (38.8)
Y40	9.25 (151)	2,500	600	3,500 (240)	-32	3.0" X 1.5"	88.2 (40.0)
Y44	10.11 (166)	2,250	600	3,250 (225)	-32	3.0" X 1.5"	90.4 (41.0)
Y49	11.23 (184)	2,250	600	3,000 (210)	-32	3.0" X 2.0"	93.0 (42.2)
Y53	12.44 (204)	2,250	600	2,750 (190)	-32	3.0" X 2.0"	95.2(43.2)
Y62	14.39 (236)	2,000	600	2,500 (172)	-32	3.0" X 2.0"	100.7 (45.7)

#### Notes:

- MAX RPM is shown at 0 in.hg. and with an appropriately sized inlet hose
- MAX motor back pressure is not to exceed 150 PSI (10 bar)
- MAX inlet vacuum is not to exceed 5in.hg. (0.17 bar)
- Weights shown are for single, direct mount pumps
- Porting shown is standard pump porting, other porting configurations are available
- Motor applications will require a case drain to be plumbed directly back to the reservoir due to excessive return line pressures or surges

The 3-D diamond-like design appearing on Muncie's hydraulic pumps is a trademark of Muncie Power Products, Inc., Muncie, Indiana (USA), registered in the United States and various foreign countries.

# DIRECT MOUNT DIMENSIONS

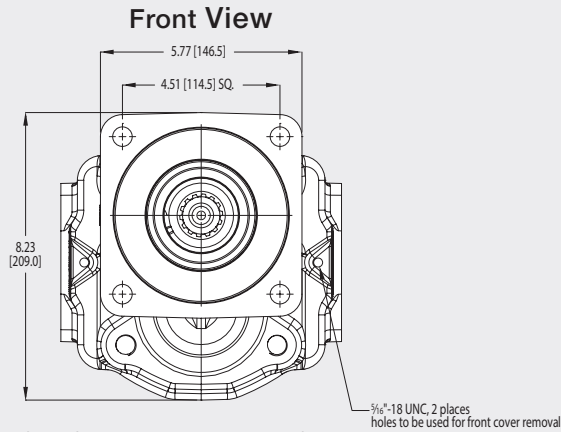

SAE "C" 4-Bolt Mounting Flange Shown

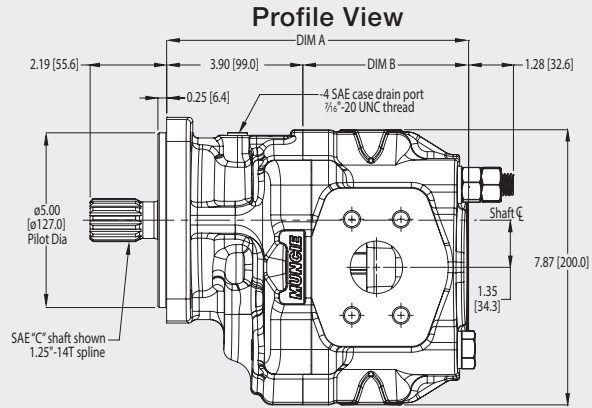

MODEL	DIM A IN (MM)	DIM B IN (MM)
Y22	8.37 [212.5]	4.47 [113.5]
Y26	8.64 [219.5]	4.74 [120.5]
Y31	8.88 [225.5]	4.98 [126.5]
Y35	9.09 [231.0]	5.64 [132.0]
Y40	9.39 [238.5]	5.49 [139.5]
Y44	9.61 [244.0]	5.71 [145.0]
Y49	9.88 [251.0]	5.98 [152.0]
Y53	10.18 [258.5]	6.28 [159.5]
Y62	10.67 [271.0]	6.77 [172.0]

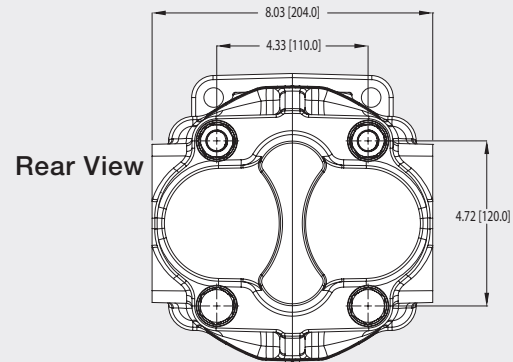

## SAE "B" 4-Bolt Mounting Flange

Shown with SAE "BB" 1.0" round shaft

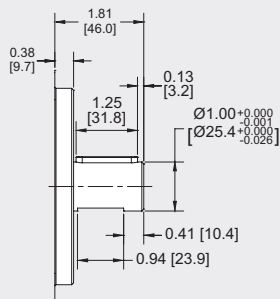
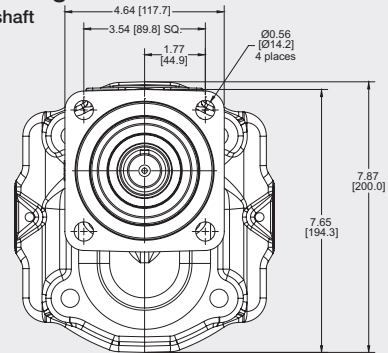
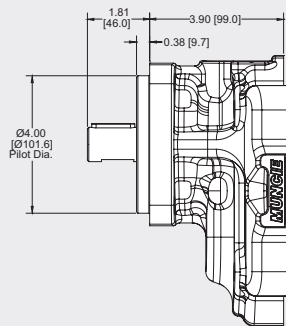

### SHAFT CODE 01

SAE "BB" 1.0" round  
Shaft with 1/4" key  
NOTE: SAE "B" pilot shown

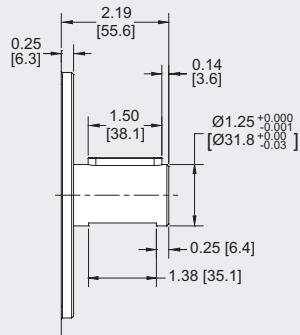

### SHAFT CODE 07

SAE "C" 1.25" round  
Shaft with 5/16" key  
NOTE: SAE "C" pilot shown

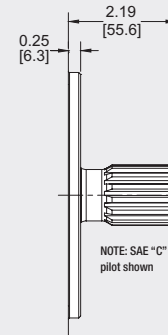

### SHAFT CODE 05

SAE "C" 1.25"-14T Spline

- SAE external involute spline
- 1.25" nominal diameter, 14 teeth
- 1/24" diametrical pitch
- Flat root side fit
- Major diameter = 1.223" - 1.228" [31.06-31.19mm]
- Minor diameter = 1.049" - 1.063" [26.66-26.99mm]

# OPTI-GRIP® DESIGN

The future of gear pump technology

The Optimum Series' integral, two piece castings are press fit together for greater structural integrity over other traditional designs.

Muncie's OPTI-GRIP technology allows for higher pressure capabilities and a more rigid pump design for long life and maintained performance.

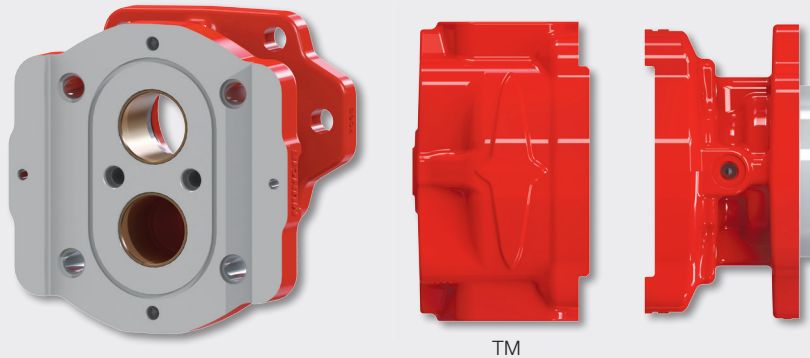

## MODEL NUMBER CONSTRUCTION

**Y-40-05-C-J3-JP XX-A-1-5-T2-26-JJ**

*For multiple units only. Delete for single units or repeat for triple units.*

**Series: Y**

**GPM (LPM) @ 1,000 RPM:**

22 (83), 26 (98), 31 (117), 35 (132), 40 (151),  
44 (167), 49 (185), 53 (200), 62 (235)

**Shaft Size & Type** (metric info where applicable):

01\* - SAE "BB" 1.00" round shaft w/1/4 key  
(25.4 rnd w/6.35 key)  
05 - SAE "C" 1-1/4-14T spline  
07\* - SAE "C" 1-1/4 round w/9/16 key (31.75 round w/7.94 key)

**Mounting Flange & Type:**

B - SAE "B" 4-Bolt  
C - SAE "C" 4-Bolt

**Mounting Flange configuration\*:**

**Bi-rotational internals (pump or motor)**

J0 - bi-rot, w/o O.B. Bearing, w/1/4" SAE drain  
(use w/splined shafts)  
J1 - bi-rot, w/O.B. Bearing, w/1/4" SAE drain  
(use w/ round shafts)  
J2 - CW port assembly, w/o O.B. Bearing, w/1/4" SAE drain  
(use w/splined shafts)  
J3 - CCW port assembly, w/o O.B. Bearing, w/1/4" SAE drain  
(use w/splined shafts)  
J4 - CW port assembly, w/O.B. Bearing, w/1/4" SAE drain  
(use w/round shafts)  
J5 - CCW port assembly, w/O.B. Bearing, w/1/4" SAE drain  
(use w/round shafts)

**Uni-rotational internals (pump only)\*\*\***

K0 - CW w/o O.B. Bearing, w/1/4" SAE drain  
(use w/ splined shafts)  
K1 - CCW w/o O.B. Bearing, w/1/4" SAE drain  
(use w/ splined shafts)  
K2 - CW w/ O.B. Bearing, w/1/4" SAE drain  
(use w/ round shafts)  
K3 - CCW w/ O.B. Bearing, w/1/4" SAE drain  
(use w/ round shafts)

**Side Ports, 2nd unit:**

See "side ports, 1st section" below

**GPM (LPM) @ 1,000 RPM, 2nd unit:**

See values for single unit at left

**Thru Drive (multiple units only):**

T0 - No thru ports  
T1 - CW thru port configuration  
(inlet port)  
T2 - CCW thru port configuration  
(inlet port)

**Assembly Sections:**

4 - Single unit, with extended studs  
5 - Tandem unit, with extended studs  
6 - Triple unit, with extended studs

**Design Number: 1**

**Additional Attributes:**

A - High pressure shaft seal\*\*  
W - Double seal for wet spline

**Rear Ports, Size & Type:**

**SAE Ports**

HE - SAE-24 x SAE-24 (Y22-35 std.)  
QD - SAE-32 x SAE-32 (Y40+ std.)  
XX - No rear ports

**Side Ports, 1st section:**

**SAE Ports**

HE - SAE-24 x SAE-24 (Y22-35 std.)  
QD - SAE-32 x SAE-32 (Y40+ std.)

**Split Flange Ports\*\*\***

JD - 2.0" SF x 1.5" SF (Y22 std.)  
JJ - 2.5" SF x 1.5" SF (Y26, 31, 35 std.)  
JP - 3.0" SF x 1.5" SF (Y40, 44 std.)  
QE - 3.0" SF x 2.0" SF (Y49+ std.)

\* It is recommended that pumps or motors with a round keyed shaft use an outboard bearing to assist with radial loads.

\*\* 150 PSI MAX back-pressure

\*\*\* Uni-rotational internals (K configuration codes) are used with split flange ports only

# OPTIMUM SERIES GENERAL INFORMATION

## Oil Recommendations

Muncie Power Products does not promote specific manufacturer's brands of oil, but does recommend the use of quality petroleum-based hydraulic fluids. Different climate temperatures require that the oil viscosity be appropriate for the operating conditions. Consult the oil manufacturer for your exact application needs.

**Note:** NEVER dilute the hydraulic fluid for cold weather operation with, including but not limited to, diesel fuel, kerosene, etc.

- **Oil Viscosity:** 60-1,000 SSU (10.5-215 cST) for continuous operation. Viscosity should not exceed 7,500 SSU (1,600 cST) at start-up.
- **Special Fluids:** Biodegradable and water-glycol type fluids are acceptable for use with the Optimum™ Series Pumps/Motors.

## Inlet/Outlet Condition

- Maximum inlet vacuum should not exceed 5 in.Hg. across all operating RPM's and temperature conditions.
- An undersized inlet port size could have maximum RPM limitations.
- An oversized outlet port size could have maximum pressure limitations.

## Operating Temperatures

Proper control of the system operating temperature is critical for long product life and the protection of all other hydraulic components.

- Ideal operating temperatures: 100°F-140°F (37.8°-60°C)
- MAX Continuous temperature: 180°F (82.2°C)
- MAX Intermittent temperature: 200°F (93.3°C)

## Hose Sizing

Hydraulic hose must be properly sized based on the oil velocity in feet per second (FPS) and of the appropriate type (SAE rating) for the specified rate of flow and pressure. The following are hose recommendations for common applications; hose requirements may differ for non-standard applications.

- Inlet hose: 2-4 FPS, SAE 100R4 type
- Pressure hose: 7-15 FPS, SAE 100R2 type
- Return hose: 4-8 FPS, SAE 100R1 type

## Filtration Recommendations

Proper filtration is vital to the life of any hydraulic system since it helps protect hydraulic components from foreign objects which may have entered the system.

- **Return Line Filters:** Return filters are always recommended with a minimum 10 micron rating. Some applications require better filtration with an absolute rating and possibly 3 or 6 micron media.
- **Pressure Filters:** Pressure filters are not typically required for gear pump applications, but they are available if desired.
- **Suction Strainers:** Suction strainers are very useful in catching large objects. Strainers should never be sized smaller than 100 mesh (149 micron), and should always include a 3 PSI (0.2 bar) bypass.

## Oil Cleanliness Recommendations (ISO 4406-1999)

- @ 2,000 PSI (138 bar): 20/17/15
- @ 3,000 PSI (207 bar): 19/17/14
- @ 4,000+ PSI (276+ bar): 17/15/12