

OPTIMUM® W SERIES

GEAR PUMPS



DESIGNED FOR OPTIMUM PERFORMANCE

The Optimum W Series gear pumps/motors offer premier performance for a wide variety of applications across several industries. Featuring the innovative OPTI-GRIP technology, the Optimum W Series exemplifies strength, endurance and rigidity making for long lasting units even in the most extreme conditions. The W Series is the smallest range of the Optimum group, providing 8 displacements to cover low flow, higher pressure requirements.

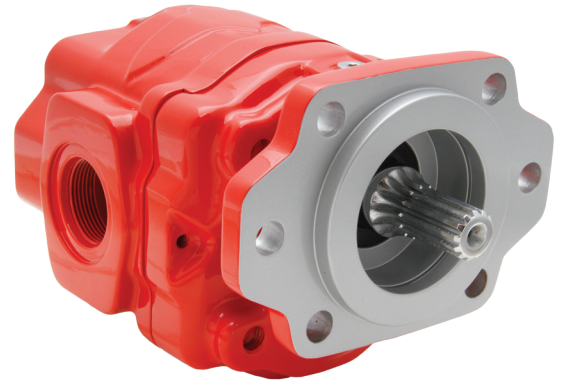

KEY FEATURES

- 8 pump displacements available
- OPTI-GRIP (patented) design
- Long life, high performance bushings
- Noise reducing, quiet design
- Bi-rotational, 4 port design standard (SAE straight thread only)
- Pressures up to 4,350 PSI (300 BAR)
- Speeds up to 3,600 RPM
- High quality, tested design
- Additional features & benefits

PUMP SPECIFICATIONS

MODEL NUMBER	DISPLACEMENT IN ³ (CC)	MAX* RPM	MIN* RPM	MAX PRES PSI (BAR)	PORTS (ODT) SIDE & REAR	PORTS (SF) SIDE ONLY	WEIGHT LBS (KG)
W06	1.45 (23.9)	3,600	800	4,350 (300)	-16	1.50" X 1.00"	40.8 (18.5)
W08	1.96 (32.2)	3,600	600	4,350 (300)	-16	1.50" X 1.00"	42.7 (19.4)
W11	2.42 (39.7)	3,250	600	4,350 (300)	-16	1.50" X 1.00"	44.0 (19.9)
W13	2.92 (47.9)	3,000	600	4,000 (275)	-20	1.50" X 1.00"	44.9 (20.4)
W15	3.46 (56.8)	2,750	600	3,750 (260)	-20	2.0" X 1.25"	47.2 (21.4)
W17	3.96 (65.0)	2,500	600	3,500 (240)	-20	2.0" X 1.25"	48.7 (22.1)
W19	4.37 (71.6)	2,500	600	3,250 (225)	-20	2.0" X 1.25"	49.5 (22.4)
W21	4.87 (79.8)	2,500	600	3,000 (210)	-20	2.0" X 1.25"	50.7 (23.0)

Notes:

- MAX RPM is shown at 0 in.hg. and with an appropriately sized inlet hose
- MAX motor back pressure is not to exceed 150 PSI (10 BAR)
- MAX inlet vacuum is not to exceed 5in.hg. (0.17 BAR)
- Weights shown are for single, direct mount pumps
- Porting shown is standard pump porting, other porting configurations are available
- Motor applications will require a case drain to be plumbed directly back to the reservoir due to excessive return line pressures or surges

The 3-D diamond-like design appearing on Muncie's hydraulic pumps is a trademark of Muncie Power Products, Inc., Muncie, Indiana (USA), registered in the United States and various foreign countries.

DIRECT MOUNT DIMENSIONS

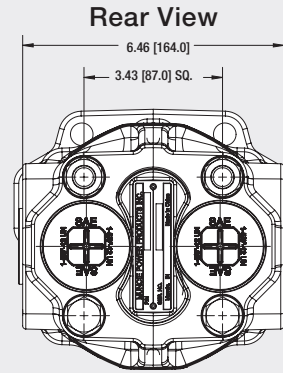
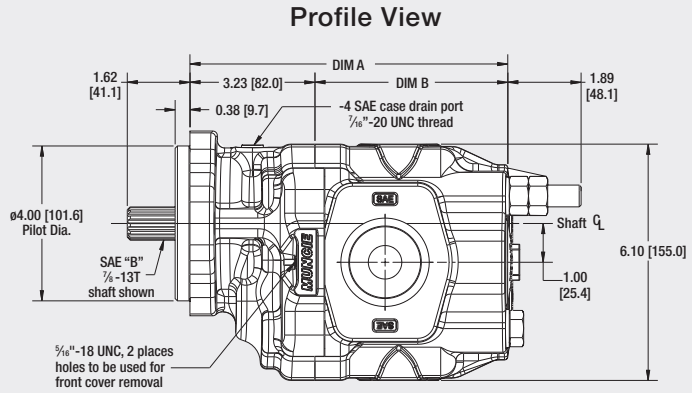
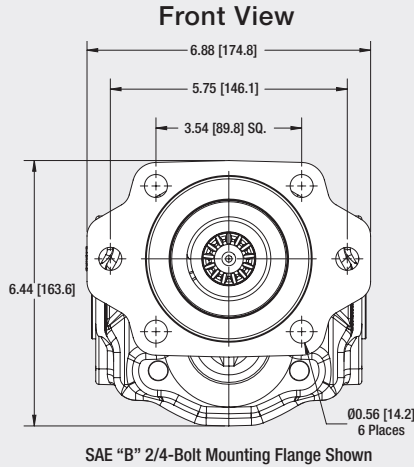

MODEL	DIM A IN (MM)	DIM B IN (MM)
W06	6.59 [167.5]	3.37 [85.5]
W08	6.83 [173.5]	3.60 [91.5]
W11	7.05 [179.0]	3.82 [97.0]
W13	7.28 [185.0]	4.06 [103.0]
W15	7.54 [191.5]	4.31 [109.5]
W17	7.78 [197.5]	4.55 [115.5]
W19	7.97 [202.5]	4.74 [120.5]
W21	8.21 [208.5]	4.98 [126.5]

SAE "A" 2-Bolt Mounting Flange Shown with 3/4" - 11T spline shaft

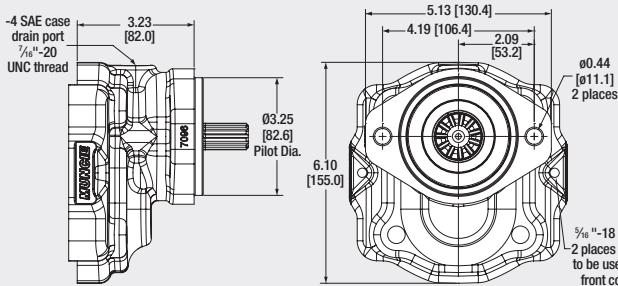

Muncie's Remote Mount "R" Mounting Flange Shown with SAE "B" 7/8" round shaft

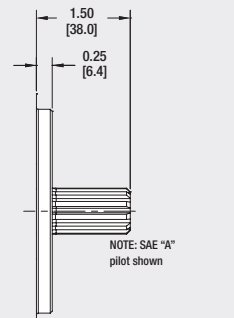
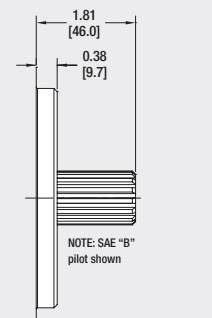
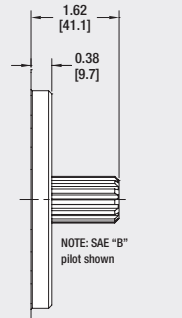
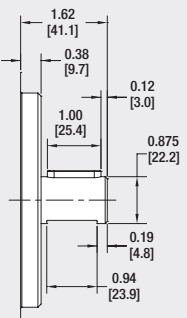
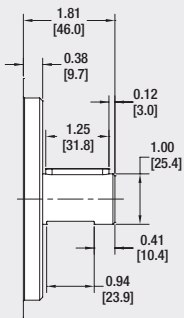
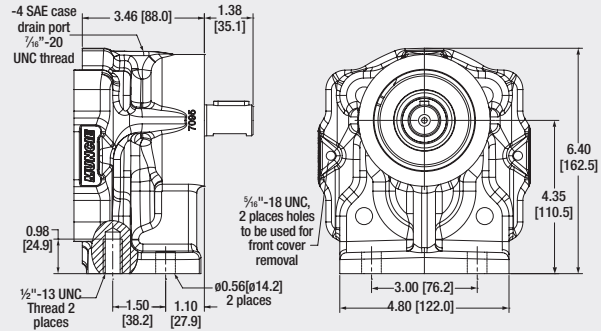

SHAFT CODE 01
SAE "BB" 1.0" Rd.
Shaft with 1/4" key
NOTE: SAE "B" pilot shown

SHAFT CODE 09
SAE "B" 7/8" Rd.
Shaft with 1/4" key
NOTE: SAE "B" pilot shown

SHAFT CODE 02
SAE "B" 7/8"-13T Spline

- SAE external involute spline
- 7/8" nominal diameter, 13 teeth
- 15/32 diametrical pitch
- Flat root side fit
- Major $\phi = 0.853" - 0.858"$
[21.67-21.80mm]
- Minor $\phi = 0.721" - 0.732"$
[18.32-18.60mm]

SHAFT CODE 17
SAE "BB" 1.0"-15T Spline

- SAE external involute spline
- 1.0" nominal diameter, 15 teeth
- 15/32 diametrical pitch
- Flat root side fit
- Major $\phi = 0.978" - 0.983"$
[24.84-24.97mm]
- Minor $\phi = 0.847" - 0.858"$
[21.52-21.80mm]

SHAFT CODE 16
3/4"-11T Spline

- SAE external involute spline
- 3/4" nominal diameter, 11 teeth
- 16/32 diametrical pitch
- Flat root side fit
- Major $\phi = 0.729" - 0.734"$
[18.51-18.64mm]
- Minor $\phi = 0.597" - 0.608"$
[15.17-15.45mm]

OPTI-GRIP® DESIGN

The future of gear pump technology

The Optimum Series' integral, two piece castings are press fit together for greater structural integrity over other traditional designs.

Muncie's OPTI-GRIP technology allows for higher pressure capabilities and a more rigid pump design for long life and maintained performance.

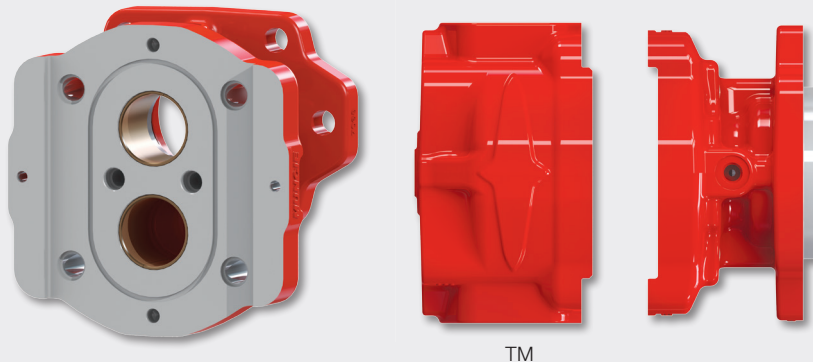

MODEL NUMBER CONSTRUCTION

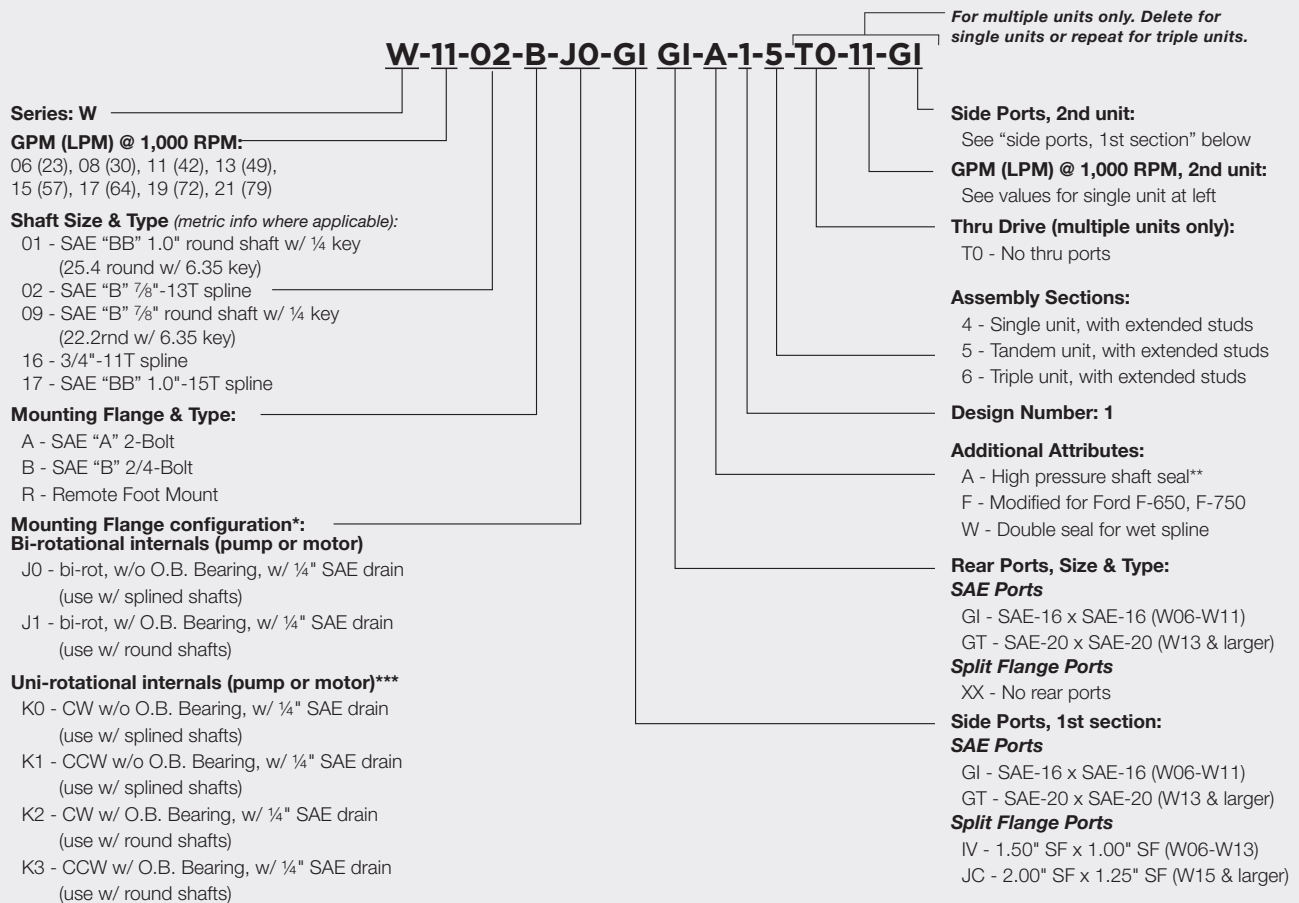

* It is recommended that pumps or motors with a round output shaft use an outboard bearing to assist with radial loads.

** 150 PSI MAX back-pressure

*** Uni-rotational internals (K configuration codes) are used with split flange ports only

OPTIMUM SERIES GENERAL INFORMATION

Oil Recommendations

Muncie Power Products does not promote specific manufacturer's brands of oil, but does recommend the use of quality petroleum-based hydraulic fluids. Different climate temperatures require that the oil viscosity be appropriate for the operating conditions. Consult the oil manufacturer for your exact application needs.

Note: NEVER dilute the hydraulic fluid for cold weather operation with, including but not limited to, diesel fuel, kerosene, etc.

- **Oil Viscosity:** 60-1,000 SSU (10.5-215 cST) for continuous operation. Viscosity should not exceed 7,500 SSU (1,600 cST) at start-up.
- **Special Fluids:** Biodegradable and water-glycol type fluids are acceptable for use with the Optimum™ Series Pumps/Motors.

Inlet/Outlet Condition

- Maximum inlet vacuum should not exceed 5 in.Hg. across all operating RPM's and temperature conditions.
- An undersized inlet port size could have maximum RPM limitations.
- An oversized outlet port size could have maximum pressure limitations.

Operating Temperatures

Proper control of the system operating temperature is critical for long product life and the protection of all other hydraulic components.

- Ideal operating temperatures: 100°F-140°F (37.8°-60°C)
- MAX Continuous temperature: 180°F (82.2°C)
- MAX Intermittent temperature: 200°F (93.3°C)

Hose Sizing

Hydraulic hose must be properly sized based on the oil velocity in feet per second (FPS) and of the appropriate type (SAE rating) for the specified rate of flow and pressure. The following are hose recommendations for common applications; hose requirements may differ for non-standard applications.

- Inlet hose: 2-4 FPS, SAE 100R4 type
- Pressure hose: 7-15 FPS, SAE 100R2 type
- Return hose: 4-8 FPS, SAE 100R1 type

Filtration Recommendations

Proper filtration is vital to the life of any hydraulic system since it helps protect hydraulic components from foreign objects which may have entered the system.

- **Return Line Filters:** Return filters are always recommended with a minimum 10 micron rating. Some applications require better filtration with an absolute rating and possibly 3 or 6 micron media.
- **Pressure Filters:** Pressure filters are not typically required for gear pump applications, but they are available if desired.
- **Suction Strainers:** Suction strainers are very useful in catching large objects. Strainers should never be sized smaller than 100 mesh (149 micron), and should always include a 3 PSI (0.2 bar) bypass.

Oil Cleanliness Recommendations (ISO 4406-1999)

- @ 2,000 PSI (138 bar): 20/17/15
- @ 3,000 PSI (207 bar): 19/17/14
- @ 4,000+ PSI (276+ bar): 17/15/12