

WARRANTY REGISTRATION AND POLICY

Buhler Manufacturing products are warranted for a period of twelve (12) months from original date of purchase, by original purchaser, to be free from defects in material and workmanship under correct, normal agricultural use and proper applications.

Buhler Manufacturing's obligations under this warranty shall be limited to the repair or exchange, at Buhler Manufacturing's option, of any Buhler Manufacturing product or part which proves to be defective as provided. Buhler Manufacturing reserves the right to either inspect the product at the buyer's location or have it returned to the factory for inspection.

The above warranty does not extend to goods damaged or subject to accident, abuse or misuse after shipment from Buhler Manufacturing's factory, nor to goods altered or repaired by anyone other than an authorized Buhler Manufacturing representative.

Buhler Manufacturing makes no Express Warranties other than those, which are specifically described. Any description of goods, including any references and specifications in catalogues, circulars and other written material published, is for the sole purpose of identifying goods and shall conform to such descriptions. Any sample or model is for illustrative purposes only and does not create an Express Warranty that the goods conform to sample or model shown.

The purchaser is solely responsible for determining suitability of goods sold. This warranty is expressly in lieu of all other warranties expressed or implied. Buhler Manufacturing will in no event be liable for any incidental or consequential damages whatsoever. Nor for any sum in excess of the price received for the goods for which liability is claimed.

WARRANTY CLAIMS:

Warranty requests must be prepared on Buhler Manufacturing Warranty Claim Forms with all requested information properly completed. Warranty Claims must be submitted within a thirty (30) day period from date of failure repair.

WARRANTY LABOR:

Any labor subject to warranty **must** be authorized by Buhler Manufacturing. The labor rate for replacing defective parts, where applicable, will be credited at a rate determined by the Company, Buhler Manufacturing.

IMPORTANT FACTS:

Buckets and Bucket Tines Carry No Warranty

Bent Spears Carry No Warranty

Snowblower Fan Shafts Carry No Warranty

Mower Blades Carry No Warranty

Portable Auger Parts Have Two (2) Year Warranty

SAFETY INSTRUCTIONS

The safety of the operator of any piece of equipment is of prime importance to the manufacturer and the following precautions should be taken when operating, starting or doing any maintenance work on this auger.

Always transport the auger in the down position carrying the weight of the auger on the winch cable and not on the transport stops.

When moving the auger on a road use red flag, or at night, if absolutely necessary, accessory lights for adequate warning to operators of other vehicles.

The auger must be on a level surface and the wheels free to move when raising or lowering. Everyone should be kept clear during these operations.

Never stand under the auger while raising or lowering.

When filling tall bins, tanks or granaries, it is advisable to anchor the auger to the bin or building to prevent it from being tipped over by the wind or a sudden movement. The upper end of auger should rest on some support when in operation.

Keep hands, feet and clothing away from exposed flighting and all moving parts. Do not allow children or anyone other than the operator close to the auger when in operation.

Before attempting to service, adjust or unclog an auger, disengage drive and shut off engine. In the case of an electric motor, shut off switch and unplug the connection.

Never operate an auger with the tail end off the ground.

When storing, the tail should be tied or weighted to prevent children or others from tipping the auger. The power source should be fixed in such a way that no one except an authorized person could start the unit.

Never raise the tail of an auger above waist high as the balance shifts forward and the auger will tip over.

Check to see that the set screws holding the PTO shaft on the gearbox shaft are firmly tightened every time you are preparing to use the auger.

**CAUTION**

1. Read and understand the operator's manual before operating.
2. Keep all safety shields and devices in place.
3. Make certain everyone is clear before operating or moving machine.
4. Keep hands, feet and clothing away from moving parts.
5. Shut off power to adjust, service or clean.
6. Support discharge end or anchor intake end to prevent upending.
7. Disconnect power before resetting motor overload.
8. Empty auger before moving, to prevent upending.
9. Lower auger to transport position for transporting.
10. Make certain electric motors are grounded.

OPERATING INSTRUCTIONS

All augers may be elevated up to 45°; however, for best operating efficiency, 35° should not be exceeded. At angles over 35° the capacity and life of the auger decreases.

Never operate an empty auger for over one minute, as the flighting and housing will experience excessive wear.

To position the auger, always tow or move the auger in the down position to a point as close as possible to the bin or barn.

 **ALERT:** Always keep the wheels level. Raise the auger to the desired height and back the auger into position. Rest the head on some support. As an auger is emptied the head becomes heavy, the tail becomes light, and the auger could tip.

 **ALERT:** Never place blocks under the wheels to increase the elevation of the auger.

Be sure the wheels are free to move and no one is standing close to the auger when raising or lowering. Never attempt to raise or lower the auger while it is in operation.

The auger is equipped with a safety brake winch. The auger may be raised or lowered by simply turning the winch handle in the proper direction until the desired discharge height is obtained.

Never have less than three wraps of cable on the drum of the winch.

 **ALERT:** Arrow on winch shows proper direction of rotation. Improper rotation may cause winch brake failure.

 **ALERT:** All wiring should be done by a competent electrical contractor to assure the electric motor is receiving the correct voltage and the cable will carry the correct load.

The lift of a motor is greatly reduced if it is run at too high or too low voltage. Also, a motor cannot develop full power if the cable is too small. The electrical supply to each motor should include an enclosed safety switch or circuit breaker of the correct size to protect the motor from being overloaded. The switch should be under a padlock to prevent the motor from being turned on by accident while working on or moving the auger. This will also prevent unauthorized person or children from operating the motor. A magnetic starter should be used to shut off the motor in case of low voltage, loss of power, or overloading the motor.

The electric motor must then be started manually.

OPERATING INSTRUCTIONS – cont'd.

Power take-off drives are designed for tractors with 540 rpm power take off and should not be run by tractors with 1000 rpm power take-off.

 **ALERT:** Always check to see that both ends of the PTO shaft are securely attached before using any PTO drive auger. This should always be done with the tractor shut off.

To assure a long life from a PTO tumbler shaft, operate the shaft at the least angle possible and always keep the tractor axle parallel to the side of the auger housing.

 **ALERT:** Always maintain at least a 6" lap on the tumbler shields. Be sure they turn freely and make certain everyone stands clear of the tractor, tumbler shaft, and auger before engaging power take-off. Be sure ends are securely connected to the auger and tractor.

Before engaging power take-off, start tractor and idle engine. Engage power take-off slowly and bring PTO RPM up to recommended speed of 500 RPM.

Before stopping auger (except in an emergency) let all grain empty out of the auger, idle engine then disengage power take-off. Shut off tractor.

 **ALERT:** When operating an auger for the first time when new or at the beginning of a season, run only partially full until flighting becomes polished. It is always a good idea to check the flighting for freedom of movement by turning pulley or tumbler shaft by hand before connecting to a power source. Other items to check are the head (spout) and intake cage for bird nests or other obstructions before starting the auger.

 **ALERT:** Always lower auger before transporting and allow the weight of the auger to rest on the winch cable and not on the transport stops.

 **ALERT:** When towing the auger, never exceed 20 miles per hour.

Always use a flag, or at night, a signal light when towing an auger on a road. Check your local regulations for further safety devices in this regard.

MAINTENANCE AND LUBRICATION

Check condition of winch cable occasionally and replace if it shows wear. The greatest wear will occur on the first few wraps around the drum of the winch.

The main thing to check on the cable is for broken strands or rust, which penetrates the cable core. This is particularly important if the auger is more than a few years old.

Oil the moving parts of the winch two times per year.

Lubricate the PTO tumbler shaft universal joints every five hours. Grease the PTO shear yoke before using PTO for the first time. Oil the moving parts of the winch two times per year.

Check the oil level of the gearbox one time per year and maintain the level at $\frac{1}{2}$ full. Use SAE90.

 **ALERT:** When replacing bearings or tightening a loose bearing collar, always tighten collar in the direction of shaft rotation using a center punch or a similar tool.

The plastic chain guard at the top of the auger must be removed to inspect or replace the chain and sprockets. When replacing the plastic guard, clean off the residue from the old silicone and apply a fresh bead using a caulking gun. There must be about 2 pounds of grease in the guard. The bolts should be tightened in a criss-cross sequence to ensure proper seating of the guard. The bolts are a $\frac{1}{4}$ " grade 5 which should be torqued to about 9 foot pounds using a torque wrench.

After every 40 hours of use, add approximately 10 squirts of grease to chain cover at the top of the auger.

If the auger is towed extensively, the wheel bearings should be repacked at least semi-annually.

STORAGE

The auger should be stored in a dry place if possible. If stored outside, lower auger to its lowest position and tie the tail end down so that no one can accidentally overturn it.

Clean auger thoroughly as dirt draws moisture and causes metal to rust. If the auger has been used to move fertilizer, clean thoroughly and apply oil or grease on entire flighting and inside the housing to stop and prevent further corrosion.

Remove belts and store in a cool dry place if auger is to be left outdoors.

At this time check all moving parts for wear and order replacement parts from your nearest dealer.

When taking the auger out of storage, clean it thoroughly and check for obstructions at the inlet and outlet ends. Check the oil in the gearbox.

Check all bolts and set screws.

ASSEMBLY INSTRUCTIONS

- Pages 13-16: Bolt the intake guard (#10) to the bottom of the auger using 3/8" x 2" hex bolts, lock washers and hex nut.
- Pages 13-16: **8" x 31' only:** The gearbox is shipped without oil. Before you mount the gearbox on the auger, remove the top plug and fill with about 500 ml of SAE90 oil. The gearbox may be used on either the left or the right side. Connect the gearbox to the driveline with a coupler (#23) using a 1/4" x 1/4" x 3 1/2" key and 3/8" x 3/8" socket set screws. Bolt the gearbox to the mounting plate on the tube using 3/8" x 3/4" hex bolts and lock washers.

⚠ ALERT: The pinion shaft of the gearbox should protrude into the 4" coupler at least 1 3/4" as shown in diagram.

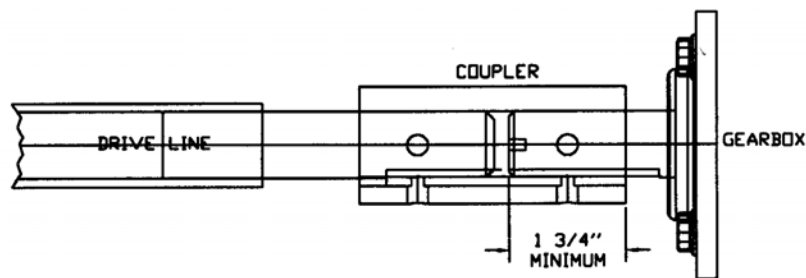

CA-02

Bolt the gearbox plate (#18) to the top of the gearbox with the ring on the drive side. The extension shield holder (#17) bolts on top of the plate with the welded bolt turned towards the top of the auger. Use the same hardware as for the gearbox.

10" x 31' ONLY: The gearbox is shipped without oil. Before you mount the gearbox on the auger, remove the lid and fill the gearbox about 1/3 full with SAE90 oil (oil should just be touching the bottom of the gears, do not overfill). Use gasket glue when replacing the cover to reduce the chance of leaks. The gearbox may be used on either the left or the right side. Check to see that the breather plug on the gearbox lid will be on the top and the drain plug will be at the bottom when the gearbox is bolted to the auger. Connect the gearbox to the splined coupler on the drive line and bolt on the gearbox using 1/2" x 1" hex bolts and lock washers. Bolt the gearbox plate (#18) to the top of the gearbox with the ring on the drive side. The extension shield holder (#17) bolts on top of the plate with the welded bolt turned towards the top of the auger. Use the same hardware as for the gearbox.

- Pages 17-19: Mount the two undercarriage arms (#1) and (#2) to the pivot pin under the welded gearbox mount using 1 1/2" washers (#7) and 5/16" x 2 1/4" cotter pins (#8). Bolt the undercarriage arms to the axle (#4) using 1/2" x 3 1/4" bolts, lock washers and hex nuts. Bolt the lift extension (#6) to the top of the two lift arms (#5). Use 1/2" x 4" bolts, lock washers and hex nuts for the 8" and 5/8" x 4 1/2" for the 10". Slide the track roller assembly (#44) onto the track with the larger roller turned to the bottom of the auger. Bolt the track stops (#25) (Page 13-16) to the top and 6" from the bottom of the track. Use 5/16" x 1" hex bolts, lock washers and hex nuts for 8" and 3/8" x 1" for the 10"

ASSEMBLY INSTRUCTIONS – cont'd.

for the 10". The cable anchor (#24) (Pages 13-16) bolts to the very bottom of the track using the same hardware. The top end of the assembled lift arm bolts to the track roller using $\frac{1}{2}$ " x $4 \frac{1}{2}$ " bolts and lock nuts for the 8" and $\frac{5}{8}$ " x 6" bolts for the 10".

⚠ WARNING: The bottom of the lift arms bolt to the inside of the welded axle brackets using $\frac{5}{8}$ " x $1 \frac{1}{2}$ " bolts and lock nuts.

The two cross tubes (#3) bolt to the undercarriage and axle using $\frac{1}{2}$ " x 3" and $\frac{1}{2}$ " x $1 \frac{1}{2}$ " bolts.

4. Pages 17-19: Bolt the winch mounting plate (#36) to the undercarriage arms using $\frac{3}{8}$ " x $2 \frac{3}{4}$ " bolts, lock washers and hex nuts. Fit the slots in the winch bracket onto the right hand cross tube and slide against the welded stop. The slots in the winch bracket at 90° to the cross tube are turned up. Bolt in place using two connector plates and $\frac{3}{8}$ " x $1 \frac{1}{4}$ " hex bolts, lock washers and hex nuts. Bolt the winch (#37) to the winch plate $\frac{3}{8}$ " x 1" hex bolts, lock washers and hex nuts. Flat washers are supplied for bolts which go through slotted holes.
5. Pages 17-19: Bolt the swivel pulley holder (#39) to loops at the top and inside of the undercarriage using $\frac{5}{16}$ " x 2" hex bolts, lock washers and hex nuts. The pulley holder is offset on the shaft. Turn so the pulley is offset to the side opposite the drive.
6. Page 28: Thread the cable (#1) as shown in the drawing, one end is clamped to the cable anchor at the bottom of the track assembly and the other end to the winch spool using the clamps provided.
7. Pages 17-19: A clevis holder (#48) bolts to the top end of one undercarriage arm using a $\frac{3}{8}$ " x 8" bolt, lock washer and hex nut. This holder is used as a place to leave the intake swivel clevis when it is removed prior to inserting the auger in a bin.
8. Pages 17-19: Mount the wheels (#35) and tires on the axle using $\frac{1}{2}$ " wheel bolts.

PTO BELT DRIVE AUGERS: Pages 20-22:

9. a) Install the hanger (#45) between the welded brackets near the bottom of the undercarriage using the 1" shaft (#46) and two $\frac{1}{4}$ " x $1 \frac{1}{2}$ " cotter pins. Turn as shown in drawing.
- b) Bolt the PTO mount assembly (#27) to the hanger using $\frac{1}{2}$ " x $1 \frac{1}{4}$ " hex bolts, lock washers and hex nuts.
- c) Bolt the guard plate (#2) to the back of the pulley guard (#38) using $\frac{1}{4}$ " x $\frac{1}{2}$ " bolts, lock washers and hex nuts. Slide onto the welded ring on the PTO mount (#27). The guard is held on by a ring (#56) with two $\frac{5}{16}$ " x $\frac{3}{4}$ " set screws and hex nuts. Hinge on guard must be up.
- d) Attach the 12" pulley (#8) to the arbor shaft (#28) using a $\frac{1}{4}$ " key (8" – 2"; 10" – $3 \frac{3}{8}$ ") and set screws.

ASSEMBLY INSTRUCTIONS – cont'd.

- e) A 13 ¾" pivot arm (#39) bolts to the inside of the guard with a 3/8" x 1" hex bolt and lock nut and to the undercarriage with a 3/8" x 2 ¾" hex bolt and lock nut. Turn as shown in drawing.
- f) Bolt a guard plate (#2) to the 6" guard (#1). Attach to the welded ring on the gearbox plate. The guard is held on by a ring (#56) mounted as in step C. Hinge on guard must be up.
- g) Bolt the 9" long guard pivot arm (#4) to the back of the guard using 5/16" x ¾" hex bolts, lock washers and hex nuts. A 10 ¾" pivot arm (#5) bolts to the end of the 9" arm and to the undercarriage. Turn arm as shown in drawing.
- h) Mount the 6" pulley (#6) on the gearbox. Fasten with a key (8"-1/4"; 10"-3/8") and set screws.
- i) Align the pulleys with the tube and mount the belts (#55).
- j) Bolt the belt tightener brackets (#40) under the gearbox with the bevel to the intake end using 3/8" bolts (8"-2 ¾"; 10"-3"), lock washers and hex nuts. The outer tightener tube (#41) bolts to the brackets using ½" bolts (8"-2 ¾"; 10"-3") and lock nuts. The inner tightener tube (#42) slides into the outer and bolts to the bottom of the hanger (#45) using ½" x 3" bolt and lock nut. Tension belts and hold in place using the set screw in the outer rod.
- k) Bolt a guard plate (#3) on the outside of the 6" guard (#1) to cover the opening using ¼" x ½" hex bolts, lock washers and hex nuts. Bolt the guard mount (#31) to the outside of the 12" guard with the same size of hardware. Slide the flexible PTO guard (#32) and the guard clamp (#33) onto the PTO shaft. Attach the PTO shaft using ¼" key, set screws and clamp bolt. Securely tighten set screws and clamp bolt. After mounting the PTO, clamp on the flexible PTO guard using a 5/16" x 1 ½" hex bolt, lock washer and hex nut.
- l) Bolt the PTO cradle (#49) & (#50) onto the lift arms for transport position. A pin in the cradle keeps the PTO shaft from falling out during transport.
- m) When belts and pulleys are aligned, bolt the bottom edges of both guards together using ¼" x ½" hex bolts, lock washers and hex nuts.

ENGINE BELT DRIVE AUGERS: Pages 24 & 25.

- 10. a) Install the hanger (#29) between the welded brackets near the bottom of the undercarriage using the 1" shaft (#18) and two ¼" x 1 ½" cotter pins. Turn as shown in drawing.
- b) The motor mount (#33) should be installed so the handle is toward the axle. Use ½" x 1 ¼" hex bolts, lock washers and hex nuts.
- c) The motor mount spacer (#37) and the guard mount (#38) fit under the motor base and are bolted on together with the gas motor. The ring on the guard mount with the gas motor. The ring on the guard mount is used to clamp on the guard for the motor pulley.
- d) Bolt the guard plate (#2) to the back of the belt guard (#1) using ¼" x ½" bolts, lock washers and hex nuts. Slide onto the welded ring on the gearbox plate. The guard is held on by a ring (#42) with two 5/16" x ¾" set screws and hex nuts. Hinge on guard must be up.

ASSEMBLY INSTRUCTIONS – cont'd.

- e) Mount the 12" pulley #4 on the gearbox using a key (8"-1/4"; 10"-3/8") and set screws.
 - f) A 10 3/4" pivot arm (#5) bolts to the inside of the guard with a 3/8" x 1" hex bolt and lock nut and to the undercarriage with a 3/8" x 2 3/4" hex bolt and lock nut. Turn as shown in drawing.
 - g) Bolt the clamp plate (#13) to the back of the engine pulley guard. Turn as shown in drawing. Clamp the guard to the welded ring on the guard mount (#38) using 5/16" x 1 1/4" hex bolts, lock washers and hex nuts. Hinge on guard must be up.
 - h) Mount the engine pulley (#39) on the gas engine. This pulley must be supplied by the customer.
 - i) Align the pulleys with the tube and mount the belts (#40).
 - j) Bolt the belt tightener brackets under the gearbox with the bevel to the intake end using 3/8" bolts (8"-2 3/4"; 10"-3") and lock nuts. The outer tightener tube (#20) bolts to the brackets using 1/2" bolts (8"-2 3/4"; 10"-3") and lock nuts. The inner tightener tube (#21) slides into the outer and bolts to the bottom of the hanger (#29) using 1/2" x 3" bolt and lock nut. Tension belts and hold in place using the set screw in the outer rod.
 - k) Bolt a guard plate (#3) on the outside of both guards to cover the opening using 1/4" x 1/2" hex bolts, lock washers and hex nuts.
 - l) The quick release on the motor mount (#33) is used when starting the engine and to stop the auger without shutting off the engine.
 - m) When belts and pulleys are aligned, bolt the bottom edges of both guards together using 1/4" x 1/2" hex bolts, lock washers and hex nuts.
11. **DIRECT DRIVE AUGERS:** Pages 26 & 27.
- a) Bolt the PTO hanger (#9) to the welded bracket on the tube using 3/8" x 1" hex bolts, lock washers and hex nuts. A pin (#7) holds the PTO in place during transport.
 - b) Mount the PTO guard holder (#14) to the welded ring on the gearbox plate using a 4" I.D. clamp (#15) with 5/16" x 1 1/4" hex bolts, lock washers and hex nuts.
 - c) Slide the flexible PTO guard (#2) and the guard clamp (#3) onto the PTO shaft. Attach the PTO shaft using a key (8"-1/4"; 10"-3/8"), set screws and clamp bolt. Securely tighten the set screws and clamp bolt. After mounting the PTO, clamp on the flexible PTO guard using a 5/16" x 1 1/4" hex bolt, lock washer and hex nuts.
12. Pages 13-16: Attach the driveline shields (#5) starting at the top of the auger. The last drive line shield (#4) has a slotted hole at one end and is bolted to the shield holder (#17) using a 5/16" flat washer, lock washer and hex nut.

ASSEMBLY INSTRUCTIONS – cont'd.

13. Re-check and tighten all bolts. Of particular importance are:

 **ALERT**

- 1) Cable Clamps!!!
- 2) Bolts on track roller assembly.
- 3) Bolts on lift arm joining axle and extension tube.
- 4) Bolts joining undercarriage, cross tube and axle.
- 5) Gearbox mounting bolts.
- 6) Pulley set screws
- 7) All bolts on shields.
- 8) Wheel bolts
- 9) Set screws and clamp bolts holding on PTO shaft.

14. NOTE: 1) Gearbox is shipped without oil. Use 400 ML of SAE 90.
a. Do not exceed 600 RPM flighting speed when operating auger.
b. An external chain tightener is supplied with all augers.

 **ALERT**

- 1) High position: It is dangerous to move auger in raised position in vicinity of electrical lines.
- 2) Keep all shields and guards in place.
- 3) Turn off power when servicing or unplugging auger.
- 4) Check that intake guard bolts are tight and that the swivel clevis pin has the hitch pin in place before transporting the auger.

SAFETY SIGNS

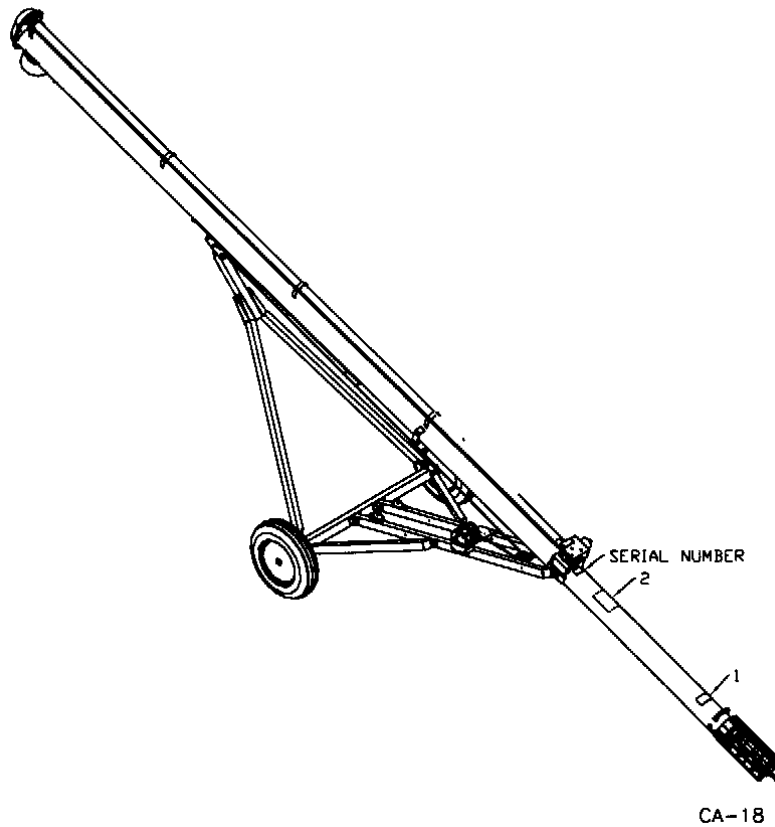

! DANGER
**KEEP HANDS
AND FEET
AWAY FROM INTAKE**
961016

! CAUTION

1. Do not operate the unit before reading and understanding the Operator's Manual.
2. Keep all safety devices in place.
3. Keep off of the equipment at all times.
4. Keep hands, feet, and clothing away from moving parts while in operation.
5. Make certain everyone is clear of the equipment before applying power or moving the machine.
6. Do not adjust, service, lubricate, clean, unclog, or move the mechanism until all power is shut off.
7. While in operation, always support the discharge end or provide adequate anchorage of the intake end to prevent sudden tipping.
8. Disconnect power of electrical driven units before resetting motor over loads.
9. To avoid tipping, make sure auger is empty before attempting to move.
10. Keep wheels of undercarriage level and on firm ground.
11. Lower unit to the recommended transport position before transporting.
12. Do not operate electric motor equipped units until they are properly grounded.
13. Keep children, visitors, and all untrained personnel away from machine while in operation.
14. Lower auger when moving close to overhead power lines.

961017

TUBE ASSEMBLY

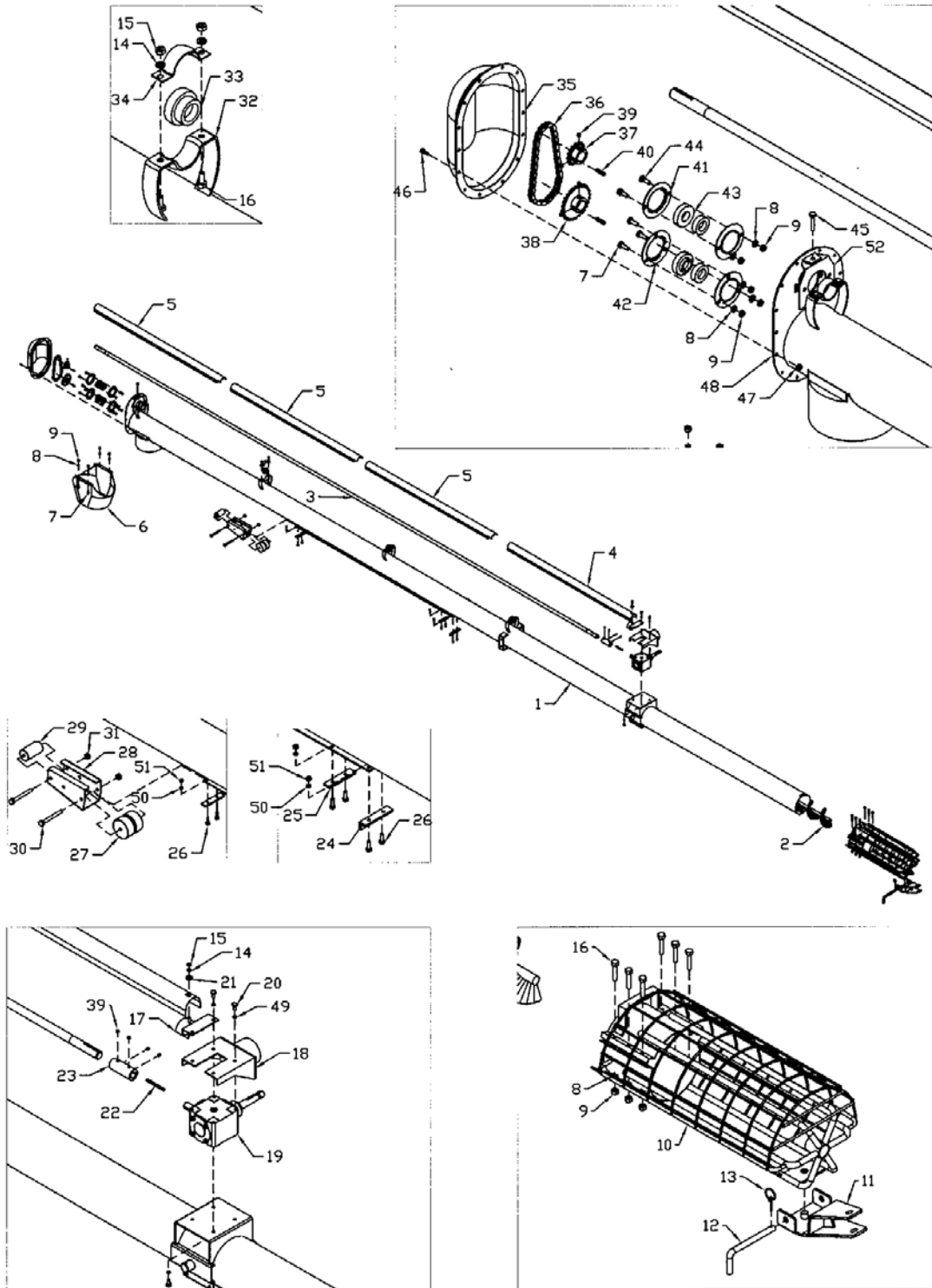

WHEN ORDERING PARTS

Always give your dealer the Model and Serial Number of your machine to assist him in ordering and obtaining the correct parts. Use the exploded view and tabular listing of the area of interest to exactly identify the required part.

TUBE ASSEMBLY

ITEM	PART #	DESCRIPTION
1	961335	8" Tube Weldment 29' Long
	961336	10" Tube Weldment 29' Long
2	961583	8" x 29' Basic Flighting
	961169	10" x 29' Flighting
3	961603	8" Drive Line 1 1/4" x 21'-9" Long
	961175	10" Drive Line 1 3/8" x 21'-8 3/4" Long
4	961337	8" Drive Line Shield 20ga x 6 3/4" x 64 1/2"
	961338	10" Drive Line Shield 20ga x 6 3/4" x 51 1/4"
5	961848	8" Drive Line Shield 20ga x 6 3/4" x 66"
	961176	10" Drive Line Shield 20ga x 6 3/4" x 53"
6	961339	10" Bolt On Spout
7	86170	3/8" x 1" Hex Bolt (pl) (10")
8	81593	3/8" Lock Washer (pl)
9	81592	3/8" Hex Nut (pl)
10	903556	8" Intake Guard Weldment
	903558	10" Intake Guard Weldment
11	903248	Clevis Weldment
12	903246	Clevis Pin 5/8" x 9"
13	966729	3/16" Linch Pin
14	81569	5/16" Lock Washer (pl)
15	81568	5/16" Hex Nut (pl)
16	811795	3/8" x 2" Hex Bolt (pl)
17	961345	Extension Shield Holder (8")
	961346	Drive Line Shield Holder (12ga) (10")
18	961347	Gearbox Plate 10ga x 7 1/2"
	961348	Gearbox Plate 10ga x 9 1/8"
19	961092	8" Gearbox
	961085	8" Reverse Shift Gearbox (Optional)
	BU50510	10" Gearbox
20	961086	10" Reverse Shift Gearbox (Optional)
	84072	3/8" x 3/4" Hex Bolt (pl) (8")
	81619	1/2" x 1" Hex Bolt (pl) (10")
21	81570	5/16" BS Flat Washer (pl)
22	961155	1/4" x 1/4" x 3 1/2" Key
23	961611	Gearbox Coupling 1 3/4" O.D. x 4" Long
	961349	Cable Anchor 1/4" x 1 " x 1" Angle (8")

24	961350	Cable Anchor 1/4" x 1 1/2" x 1 1/2" Angle (10")
25	961351	Track Stop 1/4" x 1" x 4 1/4" Long (8")
	961352	Track Stop 1/4" x 1 1/2" x 5 1/2" Long (10")
26	812026	5/16" x 1" Hex Bolt (pl)
	86170	3/8" x 1" Hex Bolt (pl) (10")
27	901758	Track Roller 3.45" O.D. x 3 1/2" Long (8")
	902364	Track Roller 3.45" O.D. x 4 1/2" Long (10")
28	961353	Track Roller Frame (10ga) (8")
	961354	Track Roller Frame (7ga) (10")
29	901759	Rear Track Roller 2" O.D. x 3 1/2" Long
	902365	Rear Track Roller 2" O.D. x 4 1/2" Long
30	811691	1/2" x 4 1/2" Hex Bolt (pl) (8")
	812087	5/8" x 6" Hex Bolt (pl) (10")
31	812364	1/2" Lock Nut (pl) (8")
	812482	5/8" Lock Nut (pl) (10")
32	961430	1 1/4" Bearing Stand (8")
	961989	1 3/8" Bearing Stand (10")
33	965818	1 1/4" Bearing (8")
	965917	1 3/8" Bearing (10")
34	961432	Bearing Holder Cap (8")
	961990	Bearing Holder Cap (10")
35	961097	Plastic End Cover (8")
	961098	Plastic End Cover (10")
36	961954	#60 Chain (42 Link) (8" Belt Drive)
	961691	#60 Chain (34 1/2 Link) (8" Direct Drive)
	961047	#80 Chain (40 Link) (10" Belt Drive)
	961181	#80 Chain (38 Link) (10" Direct Drive)
37	961684	15 Tooth Sprocket #60 (1 1/4" Bore) (8" Belt & Direct Drive)
	961041	15 Tooth Sprocket #80 (1 3/8" Bore) (10" Belt Drive)
	961998	20 Tooth Sprocket #80 (1 3/8" Bore) (10" Direct Drive)
38	961686	28 Tooth Sprocket #60 (1 1/4" Bore) (8" Belt Drive)
	961042	28 Tooth Sprocket #80 (1 3/8" Bore) (10" Belt Drive)
	961684	15 Tooth Sprocket #60 (1 1/4" Bore) (8" Direct Drive)
	961998	20 Tooth Sprocket #80 (1 3/8" Bore) (10" Direct Drive)
39	988999	3/8" x 3/8" Socket Set Screw

40	961602	1/4" Sq. x 1 1/4" Key (8")
	967041	5/16" Sq. x 1 1/2" Key (10")
41	961091	2-Hole Bearing Flange
42	961675	3-Hole Bearing Flange
43	961676	1 1/4" Bearing (8")
	965917	1 3/8" Bearing W/Collar (10")
44	81914	3/8" x 1" Carriage Bolt (pl)
45	967291	3/8" x 2" Full Thread Bolt (pl)
46	967473	1/4" x 3/4" Flange Bolt (pl)
47	967474	1/2" Flange Hex Nut (pl)
48	961301	7" & 8" Auger End Plate
	904787	10" Auger End Plate c/w Grease Nipple
49	81593	3/8" Lock Washer (pl) (8")
	81637	1/2" Lock Washer (pl) (10")
50	81569	5/16" Lock Washer (pl) (8")
	81593	3/8" Lock Washer (pl) (10")
51	81568	5/16" Hex Nut (pl) (8")
	81592	3/8" Hex Nut (pl) (10")
52	903435	Chain Tightener Bracket (8")
	903478	Chain Tightener Bracket (10")

UNDERCARRIAGE, AXLE & LIFT ARM ASSEMBLY

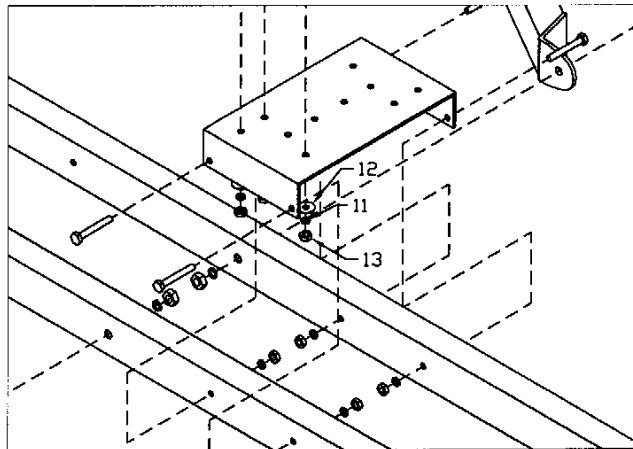
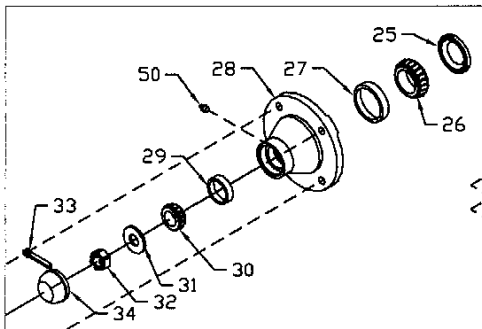
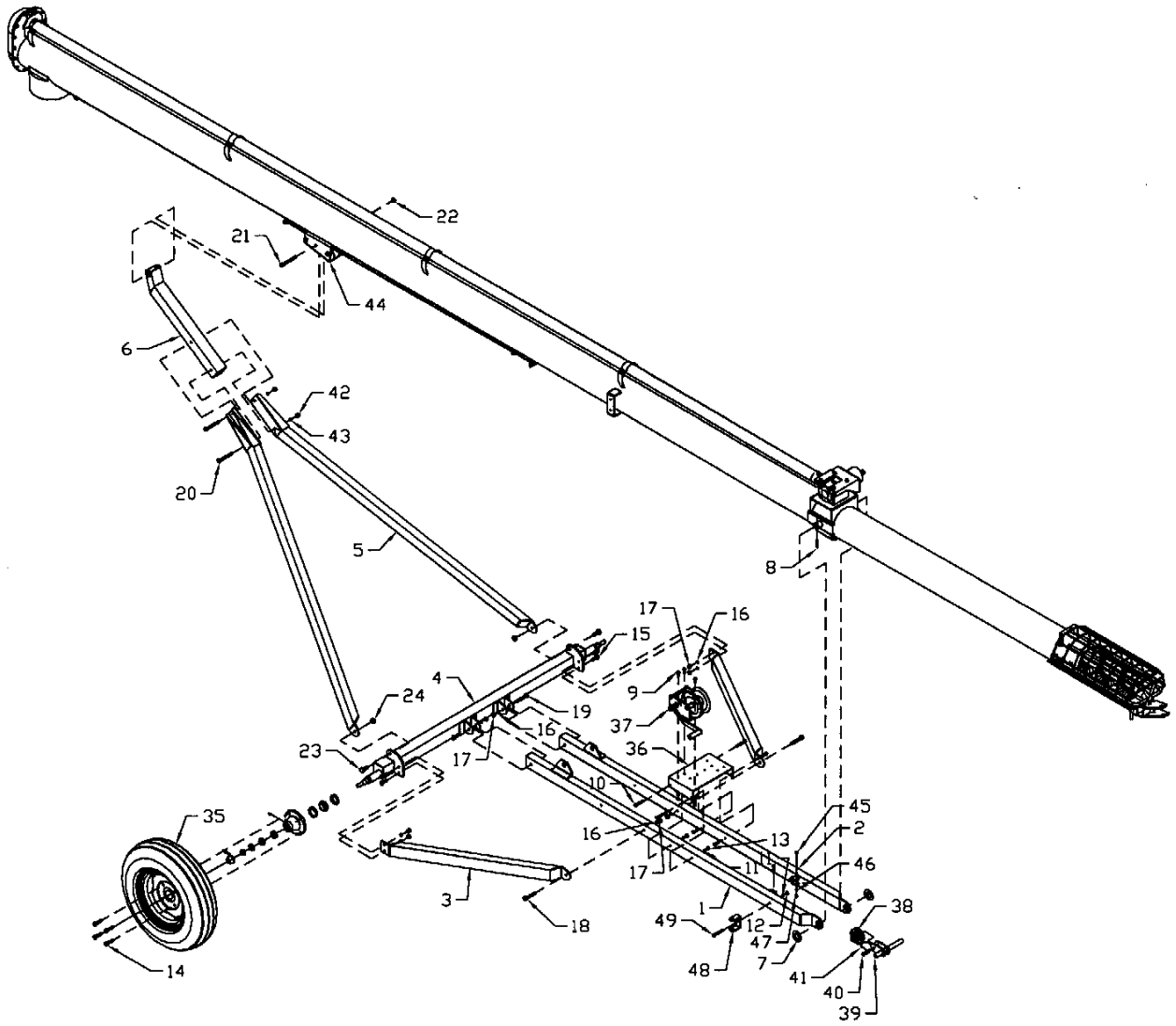

UNDERCARRIAGE, AXLE, & LIFT ARM ASSEMBLY

ITEM	PART #	DESCRIPTION
1	962067	8" RH Undercarriage Tube 2" x 3" x 92" Long
	962068	10" RH Undercarriage Tube 2" x 3" x 90" Long
2	962069	8" LH Undercarriage Tube 2" x 3" x 92" Long
	962070	10" LH Undercarriage Tube 2" x 3" x 90" Long
3	962071	Cross Tube 2" x 3" x 38 1/8"
4	905303	8" Axle 3" x 3" x 66" Long
	961326	10" Axle 3" x 3" x 66" Long
5	962074	8" Lift Arm 2" x 3" x 73 3/8" Long
	961328	10" Lift Arm 3" x 3" x 66" Long
6	961329	8" Lift Arm Extension
	961330	10" Lift Arm Extension
7	967135	1 1/2" Rim Washer (10ga) (pl)
8		5/16" x 2 1/4" Cotter Pin (pl)
9	86170	3/8" x 1" Hex Bolt (pl)
10	967488	3/8" x 2 3/4" Hex Bolt (pl)
11	81593	3/8" Lock Washer (pl)
12	84000	3/8" BS Flat Washer (pl)
13	81592	3/8" Hex Nut (pl)
14	968404	1/2" Wheel Bolt (pl)
15	84277	1/2" x 1 1/2" Hex Bolt (pl)
16	81637	1/2" Lock Washer (PL) (8")
17	81636	1/2" Hex Nut (PL) (8")
18	81627	1/2" x 3" Hex Bolt (pl)
19	81628	1/2" x 3 1/4" Hex Bolt (pl)
20	811752	1/2" x 4" Hex Bolt (pl) (8")
	81672	5/8" x 4 1/2" Hex Bolt (pl) (10")
21	811691	1/2" x 4 1/2" Hex Bolt (pl) (8")
	812087	5/8" x 6" Hex Bolt (pl) (10")
22	812364	1/2" Lock Nut (pl) (8")
	812482	5/8" Lock Nut (pl) (10")
23	84268	5/8" x 1 1/2" Hex Bolt (pl)
24	812482	5/8" Lock Nut (pl) (10")
25	961891	Oil Seal (SE11)
26	967712	Inner Cone (LM67048)
27	967711	Inner Cup (LM67010)
28	105173	4-Bolt Hub (h411)
29	968405	Outer Cup (LM11910)
30	968406	Outer Cone (LM11949)
31	9812416	3/4" S.A.E. Washer
32	81834	3/4" Crown Nut
33	981309	1/8" x 1 1/4" Cotter Pin
34	968409	Dust Cap (DC12)
	F7110	15" x 4.5" x 4-Bolt Wheel

35		
36	961331	Winch Mounting Plate 7ga x 8" x 17 3/4" (8")
	961332	Winch Mounting Plate 7ga x 9" x 20 1/4" (10")
37	961888	K1550 Winch (8")
	961945	K2550 Winch (10")
38	961846	4" Cast Cable Pulley
39	961333	Pulley Holder (8")
	961334	Pulley Holder (10")
40	961010	1/2" x 2 1/8" Clevis Pin (pl)
41	9812430	1/8" x 1" Cotter Pin (pl)
42	81636	1/2" Hex Nut (pl) (8")
	81676	5/8" Hex Nut (pl) (10")
43	81637	1/2" lock washer (pl) (8")
	81677	5/8" Lock Washer (pl) (10")
44	961385	Track Roller Assembly (8")
	961386	Track Roller Assembly (10")
45	810640	5/16" x 2" Hex Bolt (pl)
46	81569	5/16" Lock Washer (pl)
47	81568	5/16" Hex Nut (pl)
48	903392	Clevis Holder
49	81583	3/8" x 3" Hex Bolt (pl)
50	84583	Grease Fitting 1/8" NPT STR

BELT DRIVE PTO ASSEMBLY

BELT DRIVE PTO ASSEMBLY

ITEM	PART #	DESCRIPTION
1	961355	6" Pulley Guard (8")
	961356	6" Pulley Guard (10")
2	961357	Guard Plate Weldment
3	961358	8" x 8" Solid Cover Plate
4	961359	Guard Pivot Arm 9" Long
5	961360	Guard Pivot Arm 10 3/4" Long
6	961794	6" Double Pulley (1" Bore) (8")
	961074	6" Triple Pulley (1 1/2" Bore) (10")
7	988999	3/8" x 3/8" Socket Set Screw
8	961567	12" Double Pulley (1" Bore) (8")
	961004	12" Triple Pulley (1 1/4" Bore) (10")
9	81523	1/4" x 1/2" Hex Bolt (pl)
10	81545	1/4" Lock Washer (pl)
11	81544	1/4" Hex Nut (pl)
12	86170	3/8" x 1" Hex Bolt (pl)
13	81213	3/8" x 1" Square Head Set Screw
14	967488	3/8"x 2 3/4" Hex Bolt (pl) (8")
	81583	3/8" x 3" Hex Bolt (pl) (10")
15	812363	3/8" Lock Nut (pl)
16	81592	3/8" Hex Nut (pl)
17	81620	1/2" x 1 1/4" Hex Bolt (pl)
18	81626	1/2" x 2 3/4" Hex Bolt (pl) (8")
	81627	1/2" x 3" Hex Bolt (pl) (10")
19	81627	1/2" x 3" Hex Bolt (pl)
20	81637	1/2" Lock Washer (pl)
21	81636	1/2" Hex Nut (pl)
22	812364	1/2" Lock Nut (pl)
	968811	1/4" x 1/4" x 2" Key (8")
23	967044	3/8" x 3/8" x 3 3/8" Key (10")
	81578	3/8" x 1 13/4" Hex Bolt (pl) (8")
24	811791	1/2" x 2" Hex Bolt (pl) (10")
	84000	3/8" Flat Washer (pl) (8")
25	81638	1/2" Flat Washer (pl) (10")
	81592	3/8" Hex Nut (pl)
26	961362	PTO Mount Weldment (8")
	961363	PTO Mount Weldment (10")
27	961364	PTO Arbor Shaft 1"Ø x 25" Long (8")
	961365	PTO Arbor Shaft 1 1/4"Ø x 25" Long (10")
28	961792	1" Pillow Bearing W/Collar (8")
	973223	1 1/4" Pillow Bearing W/Collar (10")
29	961366	20ga x 16 3/16" Arbor Shaft Shield (8")
	961367	20ga x 12 3/4" Arbor Shaft Shield (10")

31	961368	Guard Weldment 10ga x 8" x 8"
32	961201	Flexible Guard 6" O.D. x 6 1/2" Long
33	961200	Guard Clamp 16ga x 1 1/4" x 21 1/2" Long
34	81552	5/16" x 1 1/4" Hex Bolt (pl)
35	81569	5/16" Lock Washer (pl)
36	81568	5/16" Hex Nut (pl)
37	81549	5/16" x 3/4" Hex Bolt (pl)
38	961369	12" Pulley Guard (8")
	961370	12" Pulley Guard (10")
39	961371	Guard Pivot Arm 13 3/4" Long
40	961372	Belt Tightener Bracket ga x 54" x 6"
41	961298	Outer Tightener Tube 1 5/16" O.D. x 55" Long
42	961693	Inner Tightener Tube 1" O.D. x 42" Long
43	81213	3/8" x 1" Square Head Set Screw
44	9812404	3/8" Hex Nut (br)
45	961375	Hanger Weldment (8")
	961376	Hanger Weldment (10")
46	961377	Hanger Swivel Shaft 1"Ø x 10 1/2" Long (8")
	961378	Hanger Swivel Shaft 1"Ø x 13" Long (10")
47	9812434	1/4" x 1 1/2" Cotter Pin (pl)
48	F0055	PTO Shaft (8")
	F7242	PTO Shaft (10")
49	961379	PTO Holder Weldment (8")
	961380	PTO Holder Weldment (10")
50	961381	PTO Holder Bracket (8")
	961382	PTO Holder Bracket (10")
51	12780	#7 Hair Pin Clip
52	961539	PTO Holder Pin 3/8"Ø x 4 1/2" Long
53	811792	3/8" x 1 1/2" Hex Bolt (pl)
54	81593	3/8" Lock Washer (pl)
55	961897	B-199 V-Belt (2/ 8" Auger & 3/ 10" Auger)
56	961383	Guard Holder Ring 4 1/2" O.D. x 5/8" Long
57	9812377	5/16" x 3/4" Square Head Set Screw (pl)
58	967488	3/8" x 2 3/4" Hex Bolt (pl)
59	968811	1/4" x 1/4" x 2" Key (8")
	961384	1/4" x 1/4" x 3 3/8" Key (10")
60	968811	1/4" x 1/4" x 2" Key (8")
61	81592	3/8" Hex Nut (pl) (8")
	81636	1/2" Hex Nut (pl) (10")
62	81553	5/16" x 1 1/2" Hex Bolt (pl)

ENGINE DRIVE ASSEMBLY

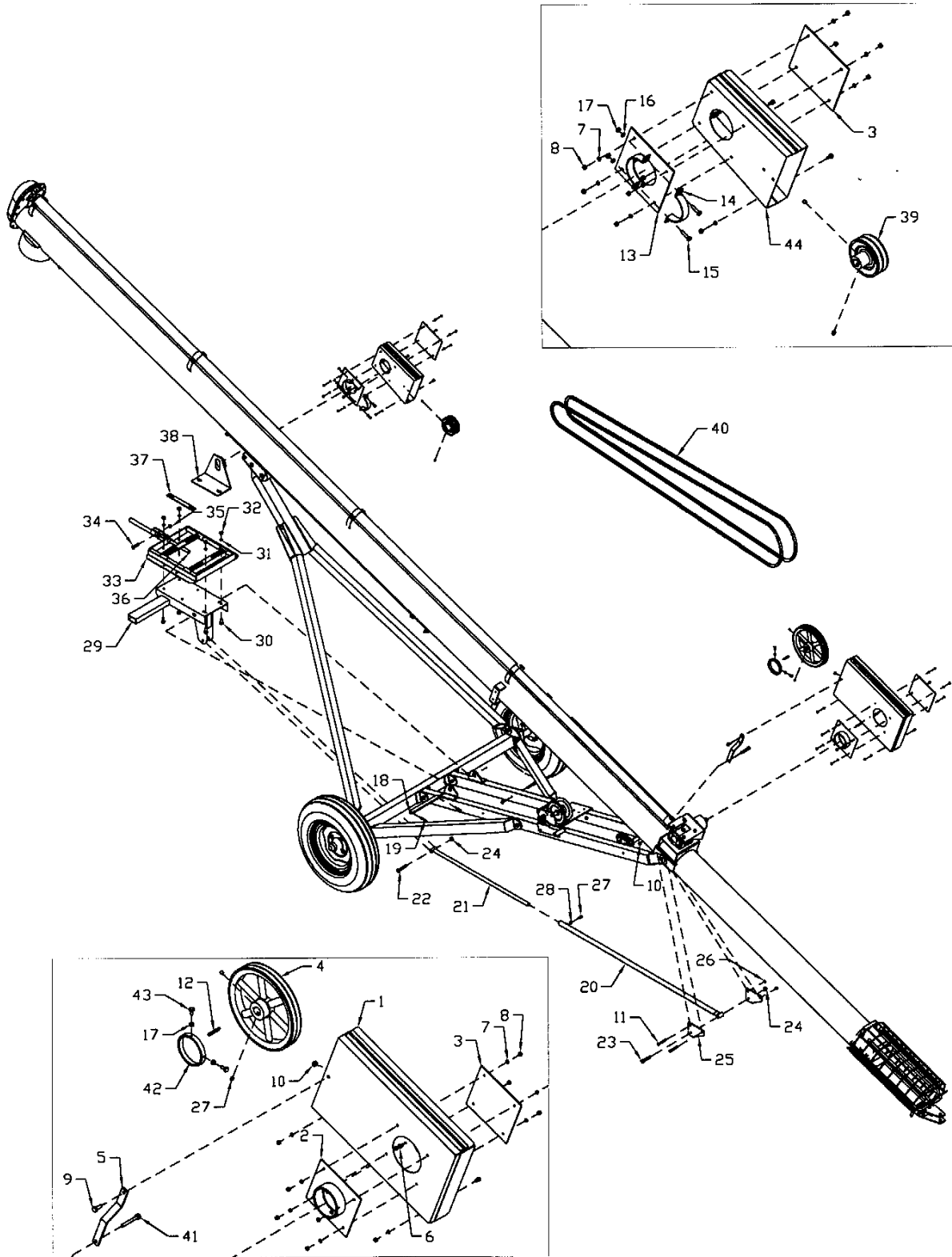

ENGINE DRIVE ASSEMBLY

ITEM	PART B31	DESCRIPTION
1	961369	12" Guard (8")
	961370	12" Guard (10")
2	961357	Guard Plate Weldment
3	961358	Guard Plate
4	961567	12" Double Pulley (1" Bore) (8")
	961187	12" Triple Pulley (1 1/2" Bore) (10")
5	961360	Guard Pivot Arm 10 3/4" Long
6	81523	1/4" x 1/2" Hex Bolt (pl)
7	81545	1/4" Lock Washer (pl)
8	81544	1/4" Hex Nut (pl)
9	86170	3/8" x 1" Hex Bolt (pl)
10	812363	3/8" Lock Nut (pl)
11	967488	3/8" x 2 3/4" Hex Bolt (pl) (8")
	81583	3/8" x 3" Hex Bolt (pl) (10")
12	968811	1/4" x 1/4" x 2" Key (8")
	967044	3/8" x 3/8" x 3 3/8" Key (10")
13	962066	Clamp Weldment
14	961896	Clamp (4" I.D.)
15	81552	5/16" x 1 1/4" Hex Bolt (pl)
16	81569	5/16" Lock Washer (pl)
17	81568	5/16" Hex Nut (pl)
18	961377	Hanger Swivel Shaft 1"Ø x 10 1/2" Long (8")
	961378	Hanger Swivel Shaft 1"Ø x 13" Long (10")
19	9812434	1/4" x 1 1/2" Cotter Pin (pl)
20	961298	Outer Tightener Tube 1 15/16" O.D. x 60" Long
21	961693	Inner Tightener Tube 1" O.D. x 36" Long
22	81627	1/2" X 3" HEX BOLT (PL) (10")
23	81626	1/2" x 2 3/4" Hex Bolt (pl) (8")
	81627	1/2" x 3" Hex Bolt (pl) (10")
24	812364	1/2" Lock Nut (pl)
25	961372	Belt Tightener Bracket 7ga x 4" x 6"
26	81592	3/8" Hex Nut (pl)
27	81213	3/8" x 1" Square Head Set Screw
28	9812404	3/8" Hex Nut (br)
29	961375	Hanger Weldment (8")
	961376	Hanger Weldment (10")
30	81620	1/2" x 1 1/4" Hex Bolt (pl)
31	81637	1/2" Lock Washer (pl)
32	81636	1/2" Hex Nut (pl)
33	961972	Motor Mount Weldment
34	981601	7/16" x 2" Hex Bolt (pl)

35	86273	7/16" Lock Nut (pl)
36	961973	12" Adjusting Rod
37	961167	Motor Mount Guard Spacer 10" long
38	961166	Guard Mount
39	F889	3 1/2" Double Pulley 1" Bore (8") 3 1/2" Triple Pulley (10") (By Customer)
40	961897	B-199 V-Belt (2/ 8" Auger & 3/ 10" Auger)
41	967488	3/8" x 2 3/4" Hex Bolt (pl)
42	961383	Guard Holder Ring 4 1/2" O.D. x 5/8" Long
43	9812377	5/16" x 3/4" Square Head Set Screw (pl)
44	961355	6" Pulley Guard (8")
	961356	6" Pulley Guard (10")

DIRECT DRIVE ASSEMBLY

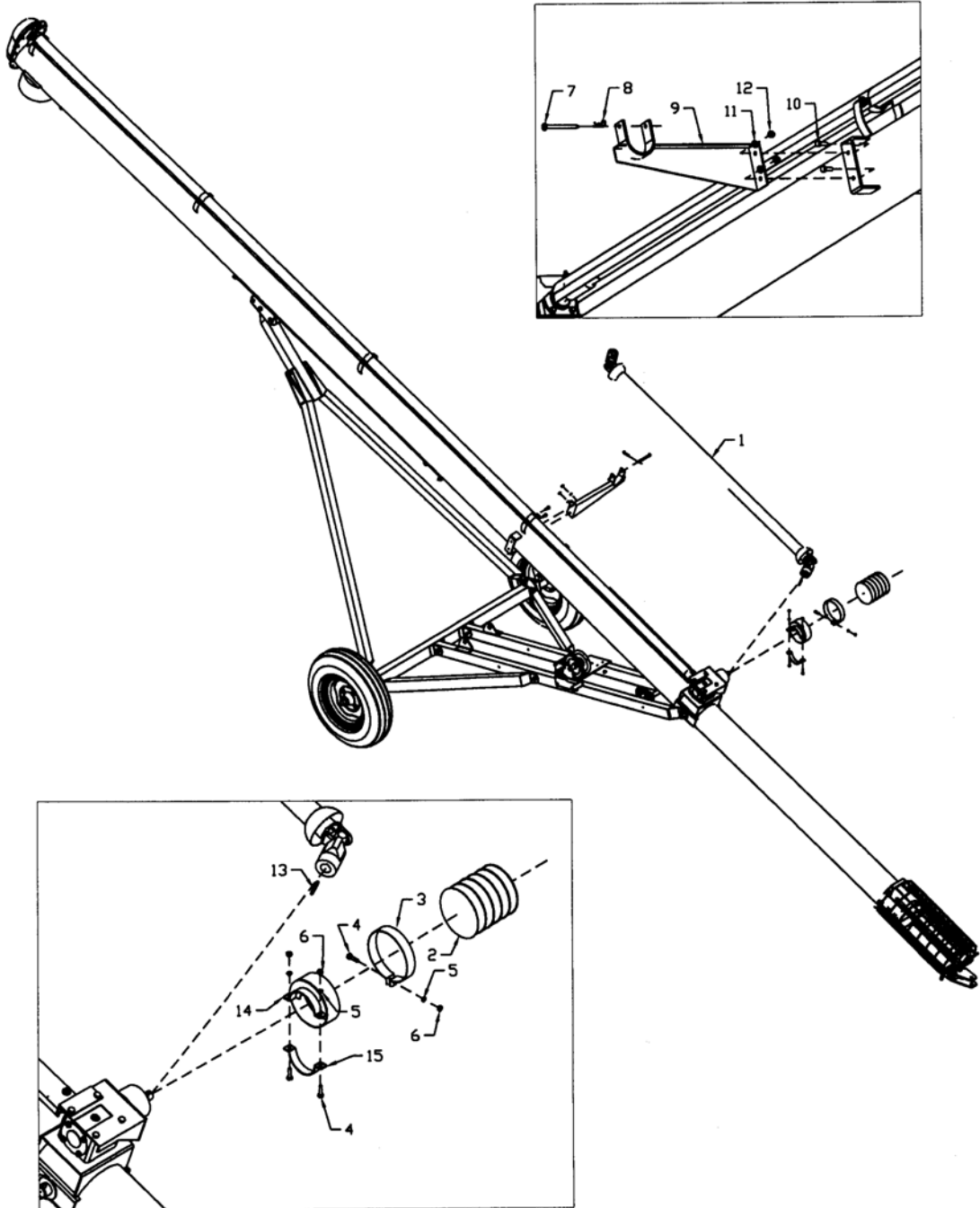

DIRECT DRIVE ASSEMBLY

ITEM	PART#	DESCRIPTION
1	F0055	8" PTO Shaft
	F7240	10" PTO Shaft
2	961201	6" Plastic Tube 6 1/2" Long
3	961200	6 1/4" x 1 1/4" Guard Clamp
4	81552	5/16" x 1 1/4" Hex Bolt (pl)
5	81569	5/16" Lock Washer (pl)
6	81568	5/16" Hex Nut (pl)
7	961539	3/8" x 4 1/2" Pin
8	12780	#7 Hair Pin Clip
9	961790	PTO Hanger
10	86170	3/8" x 1" Hex Bolt (pl)
11	81593	3/8" Lock Washer (pl)
12	81592	3/8" Hex Nut (pl)
13	968807	3/8" x 3/8" x 2" Key (10")
14	961202	PTO Guard Holder (W/4" I.D. Clamp
15	961896	Clamp (4" I.D.)

CABLE ASSEMBLY

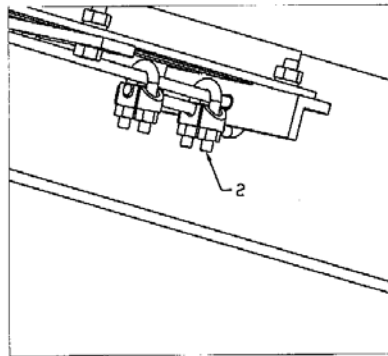
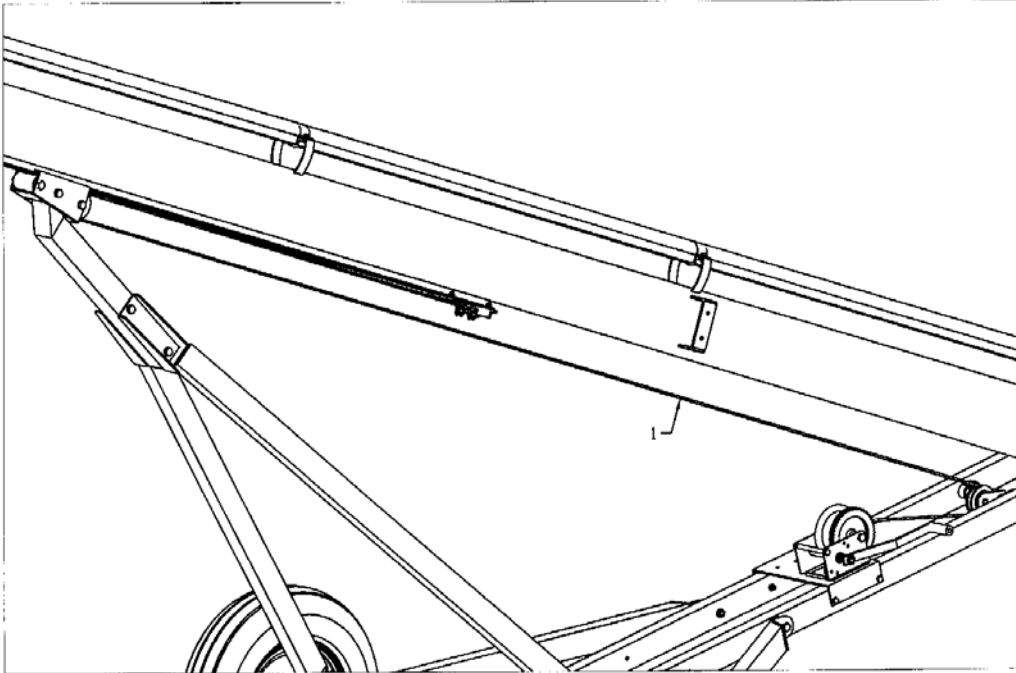

CA-07

CABLE ASSEMBLY

ITEM	PART #	DESCRIPTION
1	961641	1/4" Cable 23' Long (8")
	961140	5/16" Cable 23' Long (10")
2	961658	1/4" Cable Clamp (8")
	961763	5/16" Cable Clamp (10")

CLAMP-ON MOTOR MOUNT

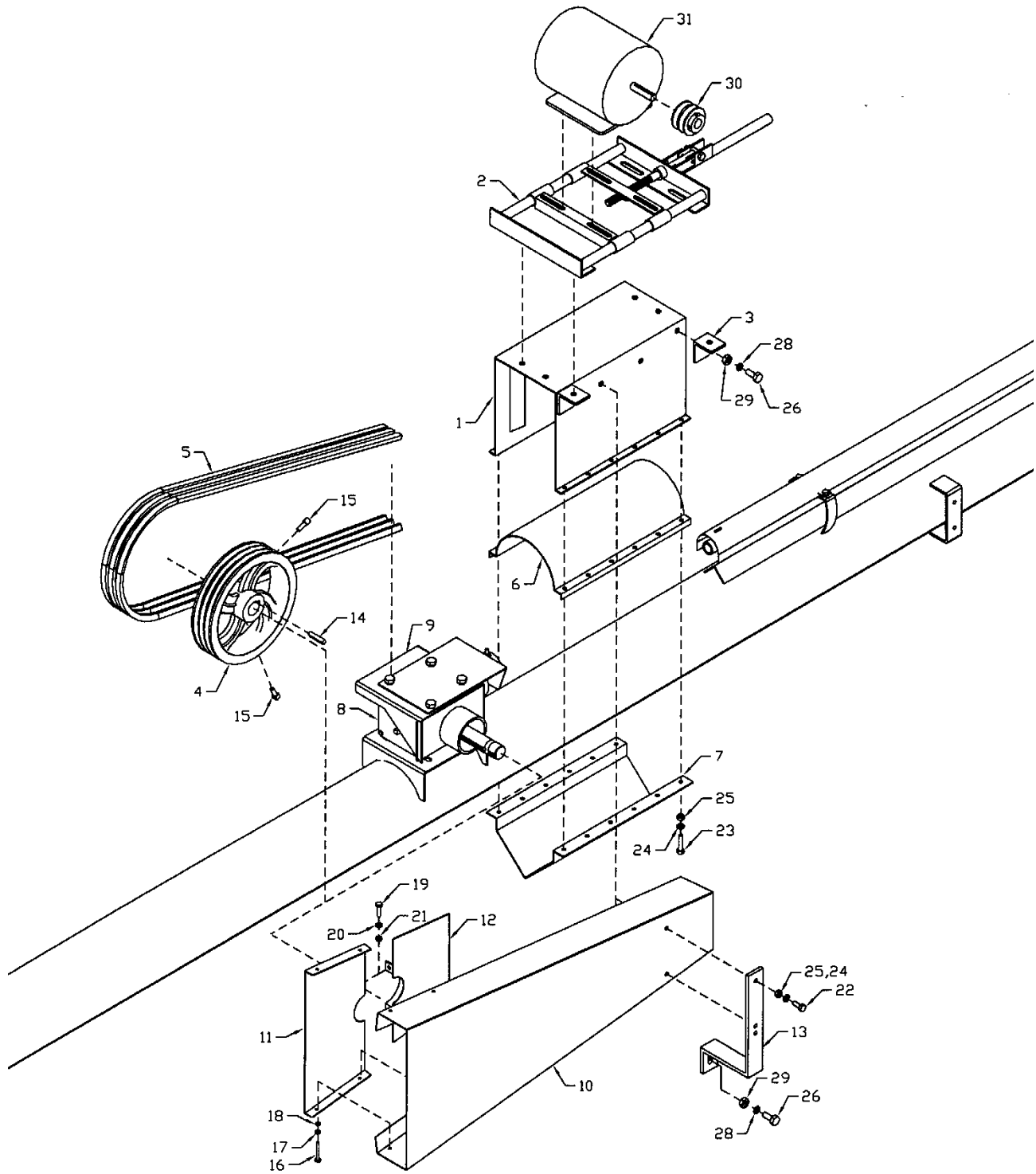

CLAMP-ON MOTOR MOUNT PARTS LIST

ITEM	PART #	DESCRIPTION
1	961196	8" Motor Mount Stand
	961184	10" Motor Mount Stand
2	961185	Motor Mount Assembly
3	961186	Angle Iron
4	961567	12" Double Pulley, 1" Bore - 8"
	961080	12" Triple Pulley, 1 1/2" Bore - 10"
5	968186	Belt B62 Match Pair 100 RPM
	973417	B-83 V-Belt (3 req'd) - 10"
6	961164	8" Round Clamp
	961191	10" Round Clamp
7	961165	8" V-Clamp
	961192	10" V-Clamp
8	961092	8" Gearbox
	BU50510	10" Gearbox
9	961347	8" Gearbox Plate
	961348	10" Gearbox Plate
10	F1870	Belt Guard (33" Long) - 8"
	F1871	Belt Guard (42 1/2" Long) - 10"
11	961159	8" Bolt-on Guard Insert
	961157	10" Bolt-on Guard Insert
12	961160	8" Clamp-on Guard Insert
	961158	10" Clamp-on Guard Insert
13	961162	Guard Bracket
14	968811	1/4" Sq. x 2" Key - 8"
	968807	3/8" Sq. x 2" Key - 10"
15	81213	3/8" x 1" Sq. Hd. Set Screw
16	81525	1/4" x 3/4" Hex Bolt
17	81545	1/4" Lock Washer
18	81544	1/4" Hex Nut
19	81552	5/16" x 1 1/4" Hex Bolt
20	81569	5/16" Lock Washer
21	81568	5/16" Hex Nut
22	86170	3/8" x 1" Hex Bolt
23	81578	3/8" x 1 3/4" Hex Bolt
24	81593	3/8" Lock Washer
25	81592	3/8" Hex Nut
26	81620	1/2" x 1 1/4" Hex Bolt
27	81638	1/2" B.S. Flat Washer
28	81637	1/2" Lock Washer
29	81636	1/2" Hex Nut
*30		Motor Pulley (Supplied by Customer)
*31		Electric Motor (Supplied by Customer)
		*See instructions for correct pulley

CLAMP-ON MOTOR MOUNT KIT INSTRUCTIONS

1. The procedure for installing the kit is the same for belt drive or direct drive. Bolt the motor mount stand #1 and the two clamps #6 and #7 together on the tube with 3/8" x 1 3/4" cap screws, lock washers and hex nuts. Bolt the angle irons #3 to the side of the stand so they are flush with the top of the stand. NOTE: The angle irons and the two extra holes on the side of the stand near the center must be on the same side as the guard.
2. Bolt the electric motor #31 to the motor mount and mount a pulley #30 (both supplied by customer). Use a double pulley for 8" augers and a triple pulley for 10" augers. Do not tighten bolts until both pulleys are aligned. The electric motor must be a 1725 rpm. Motor sizes are: 8" x 31' = 4 hp; 10" x 31' = 7 1/2" hp. Pulley sizes are: Direct Drive = 3 1/2", Belt Drive = 6"
3. Mount the 12" pulley on the gearbox using key and set screws supplied (double pulley for 8" x 31' and triple pulley for 10" x 31'). After aligning the two pulleys with the auger tube, tighten motor mount bolts and pulley set screws. Mount belts on the pulleys. The motor mount handle acts as a belt tightener.
4. Bolt the guard insert #11 to the belt guard #10 using 1/4" x 3/4" cap screws, lock washers and hex nuts. The guard assembly is then clamped to the ring on the gearbox plate using clamp #12 and 5/16" x 1 1/4" cap screws, lock washers and hex nuts. The other end of the guard is held on by a guard bracket #13 which bolts to the guard using 3/8" x 1" bolts and to the motor mount stand #1 using 1/2" x 1 1/4" bolt. Center the guard on the motor pulley before tightening bolts.

1550 WINCH
961888 - 8" X 31' AUGERS

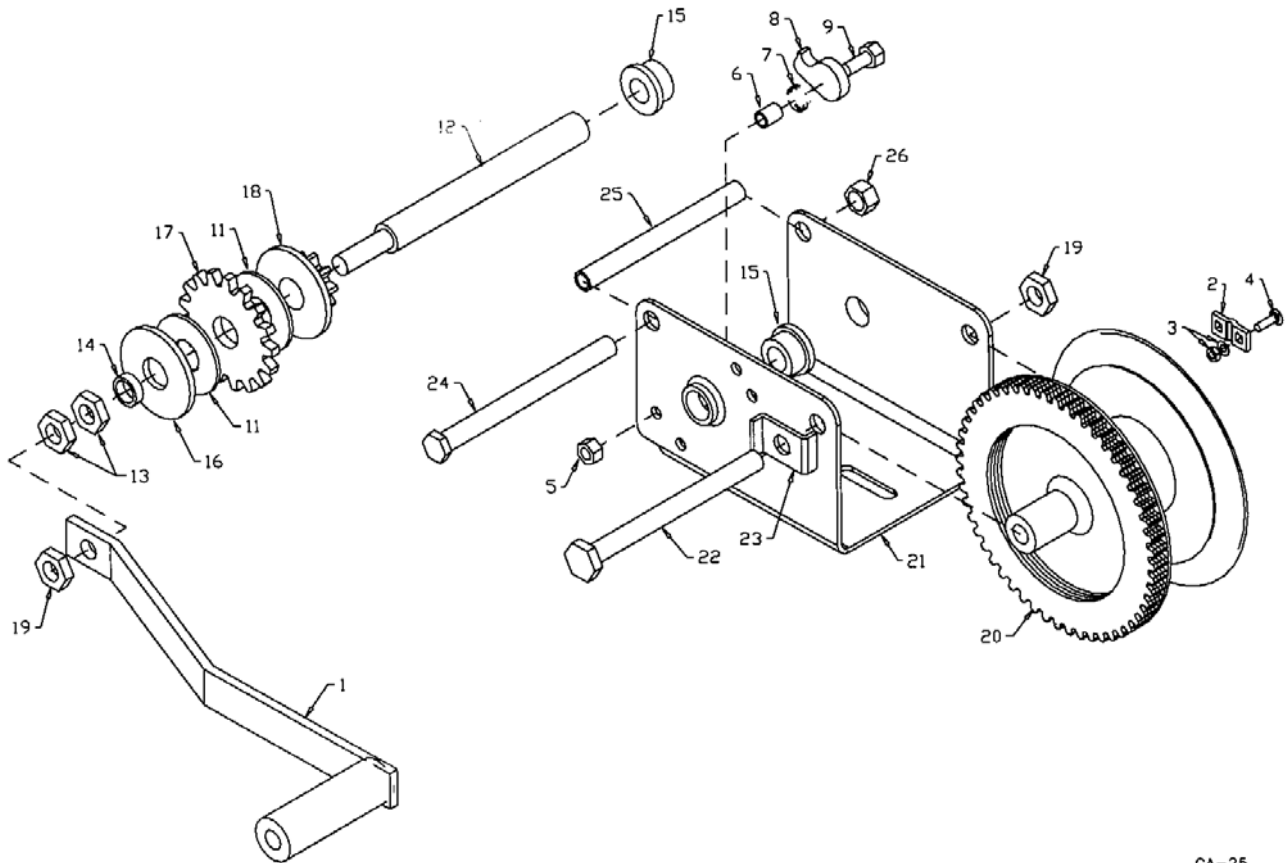

CA-25

#1550 WINCH

961888 – 8" x 31' AUGERS

ITEM	PART NAME	PART #
1	Handle Assembly	2461S01
CABLE KEEPER KIT		5621S01
2	Cable Clamp	
3	Lockwasher & Nut	
4	Carriage Bolt	
RATCHET KIT		6730S00
5	5/16" Lock Nut	
6	Ratchet Spacer	
7	Ratchet Spring	
8	Ratchet Pawl	
9	Shoulder Bolt	
11	Brake Disc Kit	
INPUT SHAFT KIT		1563S01
12	Input Shaft	
13	1/2" Lock Nut	
14	Spacer	
15	Bushing	
16	Shaft Brake Disc	
17	Ratchet Gear	
18	Pinion & Disc Assembly	
19	1/2: Lock Nut	*
20	Drum Assembly	*
21	Frame	*
22	1/2" x 5 3/4" Cap Screw	*
23	Drum Spacer	*
24	3/8" x 5 3/4" Cap Screw	*
25	Frame Spacer	*
26	3/8" Lock Nut	*
	* Not Available	

#K2550 WINCH 961945 – 10" x 31' AUGER

ITEM	PART NAME	PART #
1	Handle Assembly	2461S01
CABLE KEEPER KIT		5621S01
4	Bolt	
5	Cable Clamp	
6	Lockwasher	
7	Nut	
INPUT SHAFT KIT		1565S01
8	Input Shaft	
9	Retaining Ring	
10	Brake Disc	
11	Ratchet Gear	
12	Pinion Gear	
13	Bushing	
14	Insert	
15	Spacer	
16	Nut	
17	Friction Disc	1578S00
INTERMEDIATE SHAFT KIT		1569S01
18	Bushing	
19	Insert	
20	Insert	
21	Bushing	
22	Washer	
23	Intermediate Shaft	
24	Roll Pin	
25	Woodruff Key	
26	Gear	
RATCHET KIT		6730S00
27	Nut	
28	Spacer	
29	Ratchet Pawl	
30	Spring	
31	Shoulder Bolt	
42	Drum Bolt	
43	Lock Nut	
44	Drum Spacer	
46	Lock Nut	
47	Frame Spacer	
48	Bolt	
49	Frame	
	* NOT AVAILABLE	

PTO ASSEMBLY

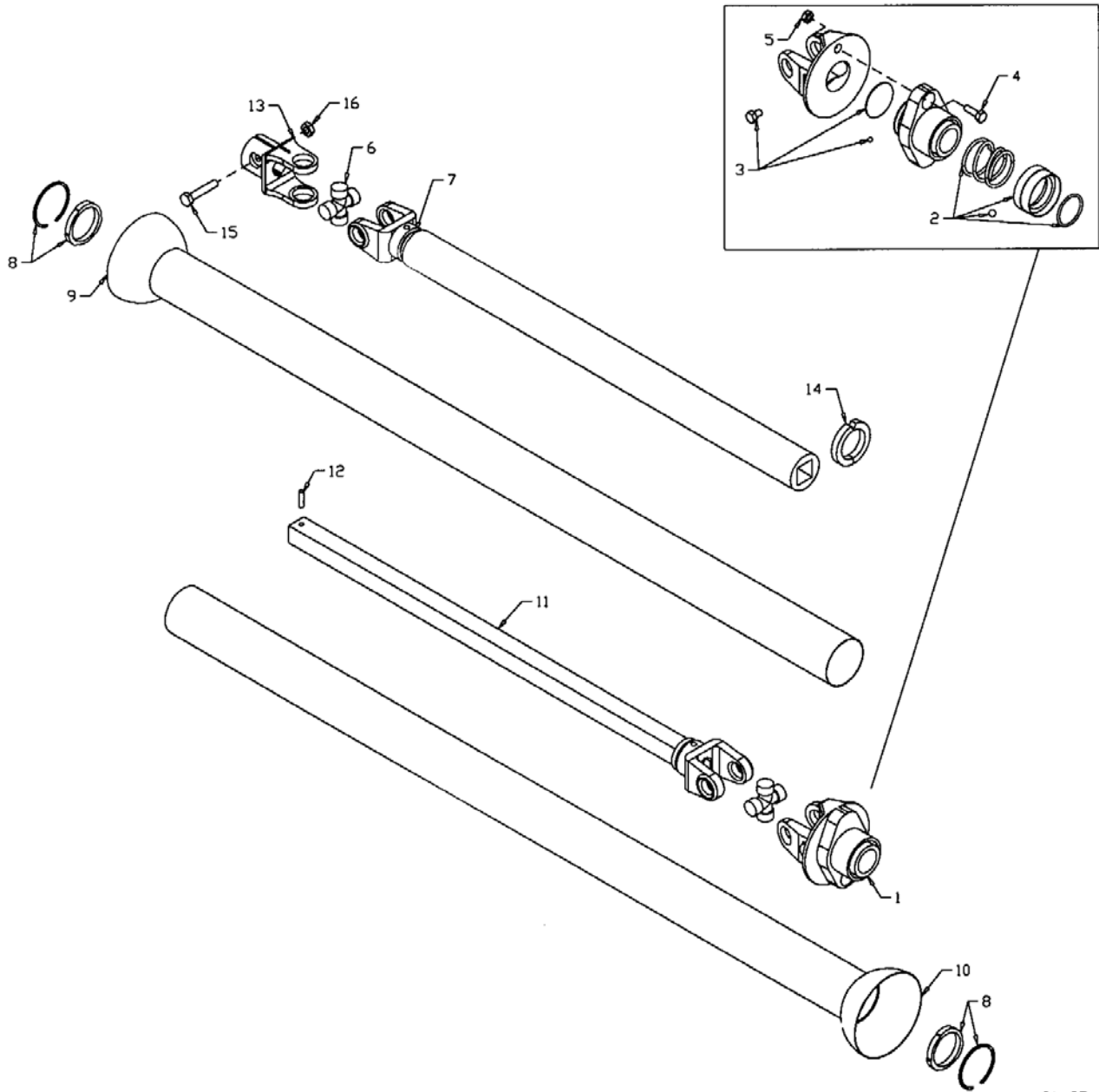

CA-27

7" & 8" Belt Drive & Direct Drive Auger PTO Assembly

Item #	Part #	Description
	F0055	Shaft Complete
	936306	Tractor Half of PTO (shear)
	936400	Implement Half of PTO
1	936308	Shear Assembly
2	936168	Spring-Lok Repair Kit - (Collar, Spring, Ret. Ring, 2 - 3/8" Balls)
3	936248	Shear Assembly Repair Kit - (3/8" x 1/2" Bolt, Blank, 24 - 1/4" Balls)
4	812026	5/16" x 1" Shear Bolt (Grade 5) - one required
5	812362	5/16" Lock Nut
6	936079	Repair Kit
7	936309	Yoke & Tube
8	936387	Bearing & Snap Ring Kit
9	936312	Inner Guard
10	936313	Outer Guard
11	936314	Yoke & Shaft
12	936315	1/4" x 1" Roll Pin
13	936374	Clamp Yoke
14	936316	Shield Bearing
15	811795	3/8" x 2" Hex Bolt
16	812363	3/8" Lock Nut

10" Direct Drive Auger PTO Assembly

Item #	Part #	Description
	F7240	Shaft Complete
	936322	Tractor Half of PTO (shear)
	936393	Implement Half of PTO
1	936324	Shear Assembly
2	936168	Spring-Lok Repair Kit (Collar, Spring, Ret. Ring, 2 3/8" Balls)
3	936248	Shear Assembly Repair Kit (3/8" x 1/2" Bolt, (Grade 5) - one required
4	86170	3/8" x 1" Shear Bolt (Grade 5) - one required
5	812363	3/8" Lock Nut
6	936093	Repair Kit
7	936325	Yoke & Tube
8	936320	Nylon Bearing Repair Kit
9	936327	Inner Guard
10	936328	Outer Guard
11	936329	Yoke & Shaft
12	936315	1/4" x 1" Roll Pin
13	936376	Clamp Yoke
14	936316	Shield Bearing
15	81628	1/2" x 3 1/4" Hex Bolt
16	812364	1/2" Lock Nut

10" Belt Drive Auger PTO

Item #	Part #	Description
	F7242	Shaft Complete
	936322	Tractor Half of PTO (Shear)
	936569	Implement Half of PTO
1	936324	Shear Assembly
2	936168	Spring-Lok Repair Kit (Collar, Spring, Ret. Ring, 2 3/8" Balls)
3	936248	Shear Assembly Repair Kit (3/8" x 1/2" Bolt, Blank, 24 1/4" Balls)
4	86170	Shear Bolt - 3/8" x 1" (Gr.5)
5	812363	3/8" Lock Nut
6	936093	Repair Kit
7	936325	Yoke & Tube
8	936320	Nylon Bearing Repair Kit
10	936327	Inner Guard
11	936328	Outer Guard
12	936329	Yoke & Shaft
13	936315	Roll Pin (1/4" x 1")
14	936262	Clamp Yoke
15	936316	Shield Bearing
16	81628	1/2" x 3 1/4" Hex Bolt
17	812364	1/2" Lock Nut

8" x 31' CONVENTIONAL AUGER GEARBOX

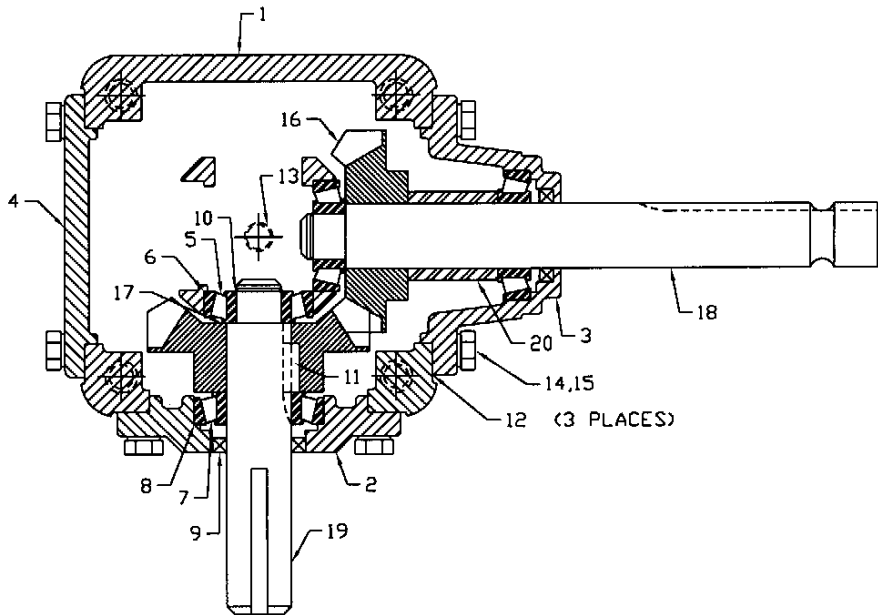

CA-28

961092 - Gearbox Parts List

Item	Part #	Description
	961092	Gearbox Complete
1	961315	Housing
2	961316	Bearing Cap
3	961317	Bearing Cap
4	961318	Cover Cap
5	93020	Bearing Cone (LM11749)
6	93019	Bearing Cup (LM11710)
7	966776	Bearing Cone (L44643)
8	966777	Bearing Cup (L44610)
9	961319	Seal (Nat. #470553)
10	961320	Retainer
11	961321	Key 1/4" sq. x 3/4" long
12	961322	Shim .005 A/R Shim .0075 A/R Shim .020 A/R
13	966784	Pipe Plug, 1/4" NPT
14	81549	5/16" x 3/4" Hex Bolt
15	81569	5/16" Lock Washer
16	961323	Gear, 90 degree Bevel, 19T
17	961324	Shim, Bearing Spacer
18	961325	Shaft
19	961326	Shaft
20	961327	Spacer Bearing

#961085 – REVERSE GEARBOX

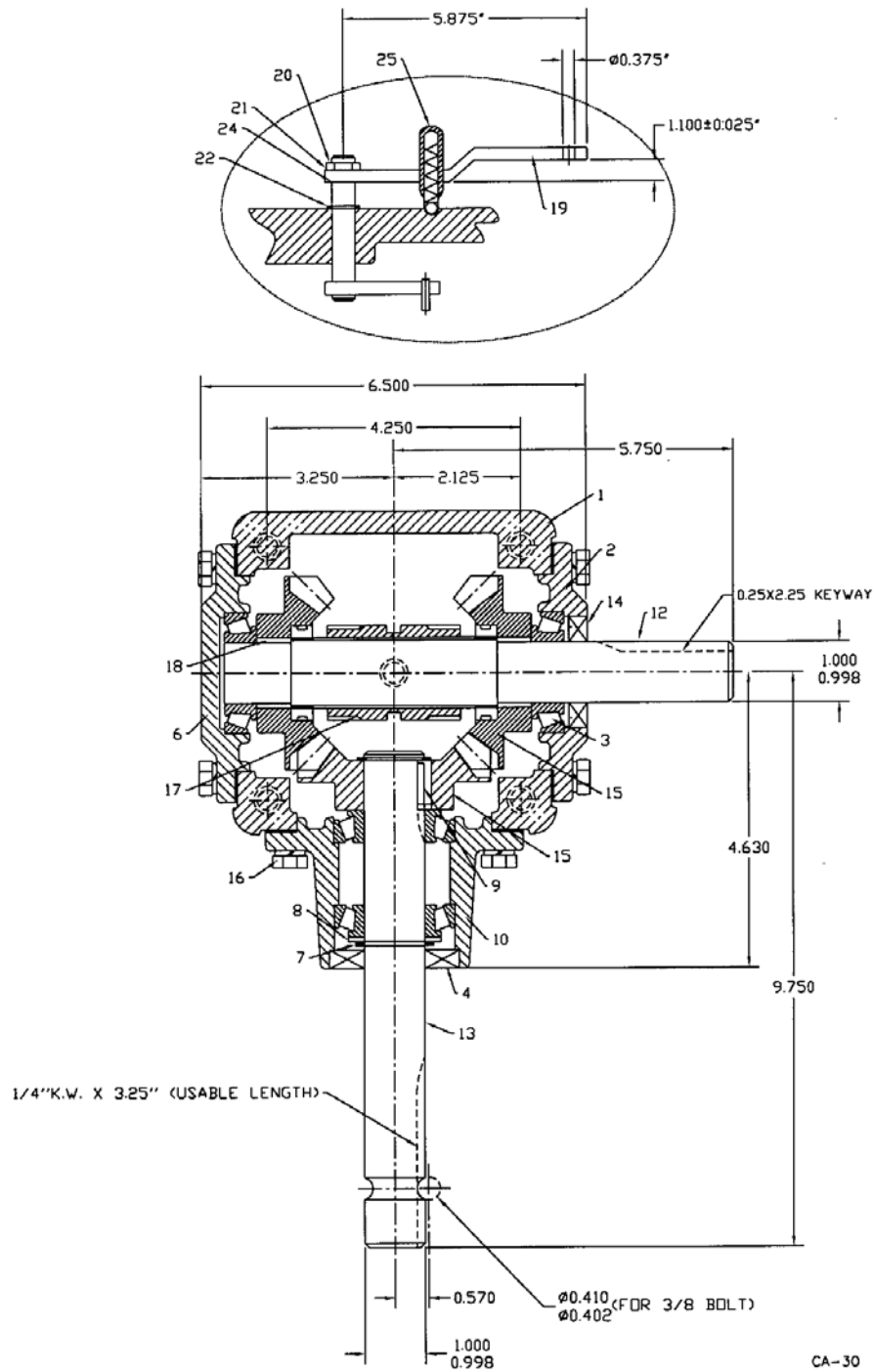

961085 - Reverse Gearbox Parts List

Item	Part #	Description
	961085	Gearbox Complete
1	906670	Case
2	961316	End Cap
3	966777	Bearing (L44643&L44610)
4	906671	End Cap
5	906672	Gear
6	906673	Seal
7	906674	Snap Ring
8	906675	Shim
9	961321	Key
10	906676	Quill
11	906677	3/8" NPT Solid Plug
12	906678	Output Shaft
13	906679	Input Shaft
14	961319	Seal
15	906680	Input Gear
16	906681	Cap Screw, 3/8" UNC x 3/4
17	906682	Dog
18	906683	Bronze Bushing
19	906684	Complete Lever
20	906685	Nylon Nut
21	906686	Washer
22	906687	Snap Ring
23	906688	Spaces
24	906689	Knob

10" x 31' AUGER GEARBOX

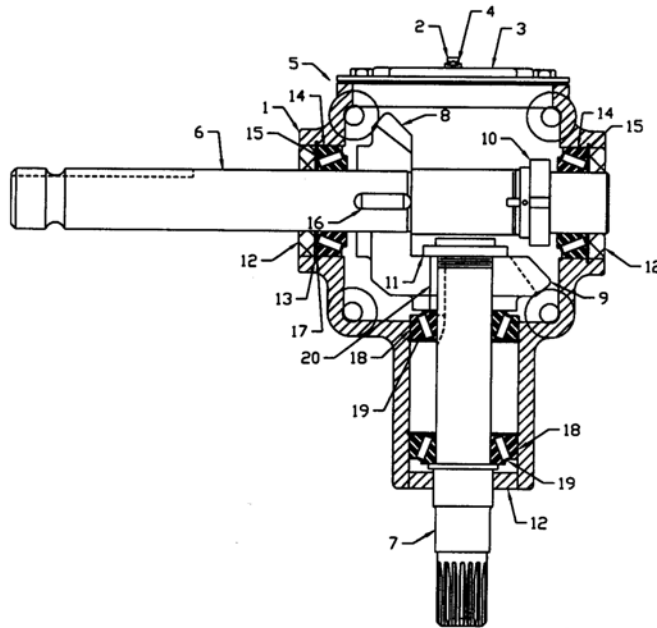

CA-29

BU50510 - Gearbox Parts List

Item #	Part #	Description
	BU50510	Gearbox Complete
1	BU50310	Gearbox Casting Only
2	BU500089-3	Pipe Plug
3	BU50457	Gearbox Cover
4	BU500167-1	Relief Valve
5	BU50458	Gearbox Gasket
6	BU50509	Cross Shaft
7	BU50502	Pinion Shaft
8	BU50329	Bevel Gear 1 1/2" B
9	BU50331	Bevel Gear 1 3/8" B
10	BU50428	Adjusting Nut
11	BU50444	Adjusting Nut
12	BU50422-1	Oil Seal (3 Used)
13	BU50415	Retainer Ring (4 Used)
14	BU575902	Bearing Cup (2 Used)
15	BU575901	Bearing Cone (2 Used)
16	BU50429	Key
17	BU50210X	Shim Set
18	BU575907	Bearing Cup (2 Used)
19	BU575906	Bearing Cone (2 Used)
20	BU50417-1	Key

8" x 61', 10" & 13" CONVENTIONAL AUGER

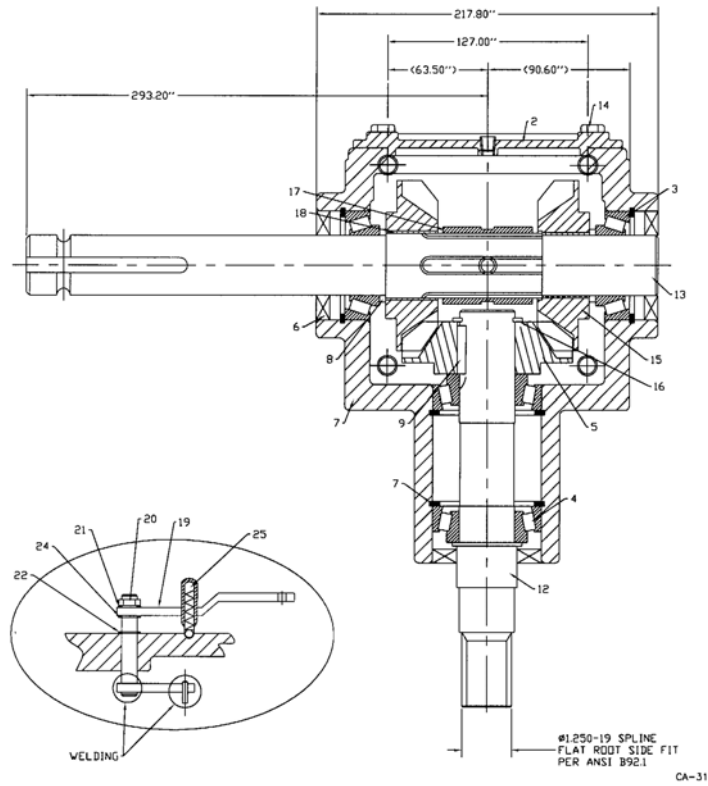

961086 - Reverse Gearbox Parts List

Item	Part #	Description
	961086	Gearbox Complete
1	906690	Case
2	906691	End Cap
3	906692	Bearing (13620&13687)
4	906693	Bearing (14276&14137)
5	906694	Gear
6	906695	Seal
7	906696	Snap Ring
8	906697	Shim
9	906698	Key
10	906699	ZG 1/8"-27 Vent Plug
11	906700	3/8" NPT Solid Plug
12	906701	Output Shaft
13	906702	Input Shaft
14	906703	Bolt 5/16" UNC x 3/4"
15	906704	Gears
16	906705	Snap Ring
17	906706	Dog
18	906707	Bronze Bushes
19	906708	Complete Lever
20	906709	Nut, Nylon
21	906710	Washer
22	906711	Snap Ring
23	906712	Spaces
24	906713	Knob

8" x 31' AUGERS – SHIPPING BUNDLES**ENGINE BELT-DRIVE AUGERS: C831E**

QUANTITY REQUIRED	BUNDLE NUMBER	DESCRIPTION
1	F8800	Basic Auger, 8" x 31'
1	F8817	Undercarriage & Axle
1	F8822	Lift Arms
1	F8874	Crate of Parts

BELT-DRIVE PTO AUGERS: C831P

1	F8800	Basic Auger, 8" x 31'
1	F8817	Undercarriage & Axle
1	F8822	Lift Arms
1	F8875	Crate of Parts

DIRECT DRIVE PTO AUGERS: C831D

1	F8801	Basic Auger, 8" x 31'
1	F8817	Undercarriage & Axle
1	F8822	Lift Arms
1	F8876	Crate of Parts

8" CLAMP-ON MOTOR MOUNT KIT: Y0064

1	F1861	8" Clamp-on Motor Mount Bundle
1	F1867	Carton of Parts
1	F1870	Belt Guard

10" x 31' AUGERS – SHIPPING BUNDLES**QUANTITY
REQUIRED****BUNDLE NUMBER****DESCRIPTION****TRIPLE BELT ENGINE DRIVE AUGER: C1031E**

1	F9900	Basic Auger, 10" x 31'
1	F9910	Undercarriage & Axle
1	F9911	Lift Arms
1	F9943	Crate of Parts

TRIPLE BELT-DRIVE PTO AUGERS: C1031P

1	F9900	Basic Auger, 10" x 31'
1	F9910	Undercarriage & Axle
1	F9911	Lift Arms
1	F9942	Crate of Parts

DIRECT DRIVE PTO AUGERS: C1031D

1	F9901	Basic Auger, 10" x 31'
1	F9910	Undercarriage & Axle
1	F9911	Lift Arms
1	F9941	Crate of Parts

10" CLAMP-ON MOTOR MOUNT KIT: Y0067

1	F1869	Carton of Parts
1	F1871	Belt Guard
1	F9508	10" Clamp-On Motor Mount Bundle