

Farm King

OPERATOR AND PARTS MANUAL

Tandem Disc

4490N Model - Medium Duty - 3 Section

Table of Contents

Introduction5

Safety.....6

- Safety Instructions6
- General Safety.....7
- Assembly Safety7
- Maintenance Safety8
- Transport Safety9
- Operation Safety9
- Safety Decals.....10
- Storage10

Specifications..... 11

- Tires 11

Assembly.....13

- Hydraulic System 19
- Wing Beam Extensions31
- Gang Pattern - 8" Spacing - 54/20.....32
- Gang Pattern - 8" Spacing - 58/20.....32
- Gang Pattern - 8" Spacing - 62/20.....33
- Gang Pattern - 8" Spacing - 70/22.....33
- Gang Pattern - 8" Spacing - 74/2234
- Gang Pattern - 8" Spacing - 74/2434
- Gang Pattern - 8" Spacing - 86/24.....35
- Gang Pattern - 8" Spacing - 94/28.....35
- Gang Pattern - 9" Spacing - 46/20.....36
- Gang Pattern - 9" Spacing - 50/20.....36
- Gang Pattern - 9" Spacing - 54/20.....37
- Gang Pattern - 9" Spacing - 62/22.....37
- Gang Pattern - 9" Spacing - 66/22.....38
- Gang Pattern - 9" Spacing - 70/22.....38
- Gang Pattern - 9" Spacing - 74/20.....39
- Gang Pattern - 9" Spacing - 78/24.....39
- Gang Pattern - 9" Spacing - 86/26.....40

Operation41

Maintenance49

Troubleshooting.....52

Parts	54
• Frame Assembly	54
• Frame Assembly Parts List.....	55
• Gang Beam Assembly	56
• Gang Beam Assembly Parts List.....	57
• Frame and Gang Beam Decals	58
• Frame and Gang Beam Decals Parts List	59
• Hitch and Leveling Crank Assembly.....	60
• Hitch and Leveling Crank Assembly Parts List.....	61
• Rockshaft and Wheel Assembly	62
• Rockshaft and Wheel Assembly Parts List.....	63
• Hydraulic Assembly	64
• Hydraulic Assembly Parts List.....	65
• Scraper Assembly	66
• Scraper Assembly Parts List.....	67
• Disc Gang Assembly.....	68
• Disc Gang Assembly Parts List	69
• Stone Flex Hanger Assembly.....	72
• Stone Flex Hanger Assembly Parts List	73
• Rockshaft Cylinder	74
• Rockshaft Cylinder Parts List.....	75
• Wing Lift Cylinder	76
• Wing Lift Cylinder Parts List.....	77
• Light Kit Assembly	78
• Light Kit Assembly Parts List.....	79
Warranty	80

Introduction

Keep this manual handy for frequent reference. All new operators or owners must review the manual before using the equipment and at least annually thereafter. Contact your Farm King Dealer if you need assistance, information, or additional copies of the manual. Visit our website at www.buhlerindustries.com/ for a complete list of dealers in your area.

The directions left, right, front and rear, as mentioned throughout this manual, are as seen facing in the direction of travel of the implement.

Safety

Safety Instructions

Remember, YOU are the key to safety. Good safety practices not only protect you, but also the people around you. Make these practices a working part of your safety program. Be certain that everyone operating this equipment is familiar with the recommended operating and maintenance procedures and follows all the safety precautions. Most accidents can be prevented. Do not risk injury or death by ignoring good safety practices.

The alert symbol is used throughout this manual. It indicates attention is required and identifies hazards. Follow the recommended precautions.



The safety alert symbol means...
ATTENTION! BECOME ALERT! YOUR SAFETY IS INVOLVED!



CAUTION

The caution symbol indicates a potentially hazardous situation that, if not avoided, may result in minor or moderate injury. It may also be used to alert against unsafe practices.



WARNING

The Warning Symbol indicates a potentially hazardous situation that, if not avoided, could result in death or serious injury, and includes hazards that are exposed when guards are removed. It may also be used to alert against unsafe practices.



DANGER

The Danger Symbol indicates an imminently hazardous situation that, if not avoided will result in death or serious injury. This signal word is to be limited to the most extreme situations, typically for machine components that, for functional purposes, cannot be guarded.

General Safety

- Have a first-aid kit available for use and know how to use it. Have a fire extinguisher available, stored in a highly visible location, and know how to use it.
- Wear appropriate protective gear. This list may include but is not limited to:
 - hard hat
 - protective shoes with slip resistant soles
 - protective glasses or goggles
 - heavy gloves
 - wet weather gear
 - hearing protection
 - respirator or filter mask
- Read and understand the Operator's Manual and all safety signs before operating, servicing, adjusting, repairing, or unplugging the equipment.
- Do not attempt any unauthorized modifications to your Farm King product as this could affect function or safety, and could affect the life of the equipment.
- Inspect and clean the working area before operating.
- Keep hands, feet, clothing, and hair away from moving parts.
- Ensure bystanders are clear of the area before operating.
- Never allow anyone to ride on the tractor drawbar, or on the disc. The person(s) riding may fall and be seriously or fatally injured.
- Disc should be operated only by persons responsible and qualified to do so.
- Never allow anyone to climb or play on the tractor or disc. They may fall and be seriously injured.

Assembly Safety

- When assembling disc, use aligning punch to line up holes. Keep fingers out of holes. Any sudden movement of heavy components will severely injure or sever your fingers.
- Use adequate manpower or hoist to lift the heavy components into place. Attempting to lift heavy components by yourself could cause serious injury.
- Be sure all bolts and hydraulic fittings are tight, and all cotter pins are installed in the slotted nuts and pins.
- Support the main and wing frames securely before assembling the components. Inadequate support may result in the heavy components falling and causing serious injury to you or person(s) nearby.
- Be sure all wheel bolts are checked for tightness during initial transport or when first discing. Loose wheel bolts may result in the wheel falling off, causing serious damage to the disc and may cause serious injury to the operator or person(s) nearby.
- To fill the wing lift cylinders with hydraulic fluid, remove the pin from the shaft end of each wing lift cylinder and pump fluid into the cylinders. Extend and contract the cylinders until they are completely filled with hydraulic fluid. The wings will free-fall if the cylinders are not completely filled with fluid, resulting in serious damage to machine or serious injury or death to person(s) nearby.
- Do not raise or lower the main or wing frames until all components are securely tightened. Loose components will cause serious damage to the disc and serious injury or death to you and person(s) nearby if the main or wing frames fell.

- Hydraulic oil escaping under pressure has sufficient force to cause serious injury. Relieve pressure in all hydraulic components before disconnecting any hydraulic components. Before applying pressure to hydraulic system, be sure all connections are tight and components are not damaged. If injured by escaping hydraulic fluid, see a medical doctor immediately.
- When attaching gang assemblies, wear protective gloves to prevent injury from cutting edges of blades.
- Before applying pressure to the hydraulic system, be sure all connections are tight and the components are not damaged.
- Wings will free fall if wing cylinders is not full of oil causing serious damage to machine or serious injury or death to person(s) nearby.
- When assembling gangs ensure adequate support is placed under main frame and wing frame. Do not use lock out valves as safety devise to prevent frame from falling. If any hydraulic component failed, disc could drop causing serious injury or death to person(s) nearby.

Maintenance Safety

- Do not loosen or disassemble hydraulic components when there is pressure within those components. Hydraulic components under pressure may cause parts and hydraulic fluid to fly out at a high velocity, which could cause serious injury. Always relieve the pressure in the hydraulic system before making adjustments to the hydraulic system. If injured by escaping hydraulic fluid, see a medical doctor immediately.
- Check all hydraulic hoses periodically for signs of ruptures and leaks. Always use wood or cardboard as a backstop, and wear gloves and eye protection when searching the hydraulic system for leaks. Spurting hydraulic fluid can cause injury if it penetrates the skin or the eyes. If injured by escaping hydraulic fluid, see a medical doctor immediately.
- Always relieve the pressure in the hydraulic system when the disc is not being operated.
- Always permit parts which contain hot fluid to cool to a safe temperature before handling or disconnecting these parts.
- Always wear safety glasses or goggles and gloves when working on the hydraulic system.
- To fill wing lift cylinders with hydraulic oil, extend and contract cylinder within slot on wing until cylinders are completely filled with oil. Do not fold wing until cylinder is completely filled, wing will free fall if cylinders are not filled with oil, causing serious damage to machine or serious injury or death to person(s) nearby.
- Lower the disc to the ground when servicing or making adjustments. If the disc must be serviced in the raised position, place blocks under frame. Do not rely on hydraulics lock up valves as a safety device. If the hydraulic system failed, or if the hydraulic lever was accidentally operated, the disc could drop.
- Do not lubricate disc while it is in motion. You may fall in front of disc and be seriously or fatally injured.
- Always place all tractor controls in neutral and lock brakes when hitching disc to tractor. Tractor could roll backwards when hitching disc.
- If a wing lift cylinders or wing lift hydraulic hoses are removed when wings are folded into transport position, always install a safety chain between wing frame and main frame to prevent wings from falling. If wings fell serious injury or death could occur to person(s) nearby and machine would be damaged severely.

Transport Safety

- When trailing the disc over public roads, use the SMV emblem and warning light for protection of tractor and other motor vehicle operators. Check local laws for width and height maximums.
- When transporting disc always place both hydraulic lock up valves in “closed” position. If hydraulic lever was accidentally operated the disc could drop or wings could fall causing serious injury or death to operator or person(s) nearby.
- Do not exceed 10 mph (16 km/h) when transporting the disc on smooth surfaces. Reduce speed when transporting on rough surfaces. Excessive speed could cause loss of tractor control and damage to disc and tractor. Do not transport the disc with any other vehicle except a tractor.
- When transporting disc always install the complete package of depth control stops (17" long) on shaft of main frame cylinder. If any component of hydraulic system failed disc could drop causing serious injury or death to operator or person(s) nearby.
- Always attach a safety chain to the tractor drawbar and the disc hitch before transporting the disc. The safety chain will help control disc should it accidentally separate from the drawbar. Use a chain with a strength rating greater than the gross weight of the towed machine. Serious damage, injury or death could result from the disc separating from the tractor drawbar.
- Check all reflectors and visibility and cleanliness before transporting the disc. It is important that the reflectors are clean and visible, especially during the evening hours.
- Regulate your speed on hillsides and curves when transporting the disc. Loss of tractor control could result in serious damage to the disc and possible serious injury or death to you or person(s) nearby.
- Never allow anyone to ride on drawbar of the tractor or on the disc. The person riding may fall and be seriously injured.
- When transporting disc always install the complete package of depth control stops (17" long) on shaft of main frame cylinder. If any component of hydraulic system failed disc could drop causing serious injury or death to operator or person(s) nearby.

Operation Safety

- Be sure person(s) are standing clear before starting or moving the tractor and disc.
- Only one (1) person (the operator) should be permitted on the tractor when the disc is in operation, and he/she should be familiar with repair procedures and temporary first aid treatment.
- Never stand between the tractor and disc when hitching disc to the tractor UNLESS all tractor controls are in neutral and the park brake is set. The tractor could roll backwards, which could result in serious injury or death to you or person(s) nearby.
- When operating on hillsides, use extreme care. The tractor may tip over if it strikes a hole, ditch or other irregularity.
- To avoid personal injury or death, always stay clear of the folding wing when it is being raised, lowered or in the folded position. If the hydraulic system failed, or if the hydraulic lever was accidentally operated, the wing could drop, resulting in serious injury or death to you or those nearby.
- Do not stand under wing while wing is being raised or lowered. If any components of hydraulic system should fail, or if hydraulic lever should accidentally be operated, wing could drop causing serious injury or death.

Safety Decals

- Keep all decals clean and in good condition to provide you with a constant reminder of safe operating procedures.
- Replace any destroyed, missing or illegible decals.

Storage

- Wings may unfold due to thermal expansion of hydraulic oil causing damage to disc, property or severe injury or death to person(s) nearby. Release pressure in all cylinders then close hydraulic lockup valves before unhitching from tractor or when parking with tractor.

Specifications

Model	Wing Width	Blade Spacing	Approx. Cutting Width	# of Blades	# of Gang Bearings	Gang Bearing Type		Approx. Transport Width	Approx. Transport Height
54SN		8"	18-1/2'	54	18	211	410WSS		10'0"
58SN		8"	20'	58	20	211	410WSS		10'6"
62SN		8"	21'	62	20	211	410WSS		11'1"
70N	96"	8"	24'	70	22	211	410WSS	11'6"	12'4"
74N	96"	8"	25-1/2'	74	22	211	410WSS	11'6"	12'11"
78N	68"	8"	27'	78	24	211	410WSS	11'6"	13'7"
86W	68"	8"	29-1/2'	86	24	211	410WSS	11'6"	14'10"
94W	68"	8"	32'	94	28	211	410WSS	11'6"	16'1"
46SN		9"	18'	46	20	211	410WSS		10'0"
50SN		9"	19-1/2'	50	20	211	410WSS		10'9"
54SN		9"	21'	54	20	211	410WSS		11'6"
62N	96"	9"	23-1/2'	62	22	211	410WSS	11'6"	12'3"
66N	68"	9"	25'	66	22	211	410WSS	11'6"	13'0"
70N	68"	9"	26-1/2'	70	22	211	410WSS	11'6"	13'8"
78W	68"	9"	29-1/2'	78	24	211	410WSS	11'6"	15'1"
86W	96"	9"	32-1/2'	86	26	211	410WSS	11'6"	16'6"

Tires

Size	Total # of Wheels	Wing Wheel Type	M/FTire Size	M/FTire Pressure	W/FTire Size	W/FTire Pressure
23-1/2' to 27'	6	Single	11 L 15 FI Load Range "F"	55 PSI	11 L x 15 FI Load Range "D"	50 PSI
29-1/2' to 32-1/2'	8	Dual	11 L x 15 FI Load Range "F"	55 PSI	11 L x 15 FI Load Range "D"	50 PSI

Gang Angle

- Front Gang - Fixed - 20 Degrees
- Rear Gang - Fixed - 17 Degrees

Hydraulic Cylinders

- Wing Lift (2) - 5" x 36" (127mm x 914mm)
- Lift (1) - 4" x 24" Rephasing (88.9mm x 610mm) Centre Frame
- Lift (1) - 3-1/2" x 24" Rephasing (88.9mm x 610mm) LH Wing
- Lift (1) - 3" x 24" Rephasing (76.2mm x 610mm) RH Wing

Bolt Torques

- Gang bolts - 1-15/16" (49mm) diameter 3200 ft lbs (4336 N.m)
- Leveling crank bolts - 1-1/4" (31mm) diameter 840 ft (1138.2 N.m)
- Wheel bolts - 9/16" (14mm) diameter 150 ft lbs (203.25 N.m)
- Bearing hanger u-bolts - 5/8" (15mm) diameter 150 ft lbs (203.25 N.m) (Solid Hangers)
- Bearing hanger u-bolts - 3/4" (19mm) diameter (352.3 N.m) (Solid Flex Hanger)

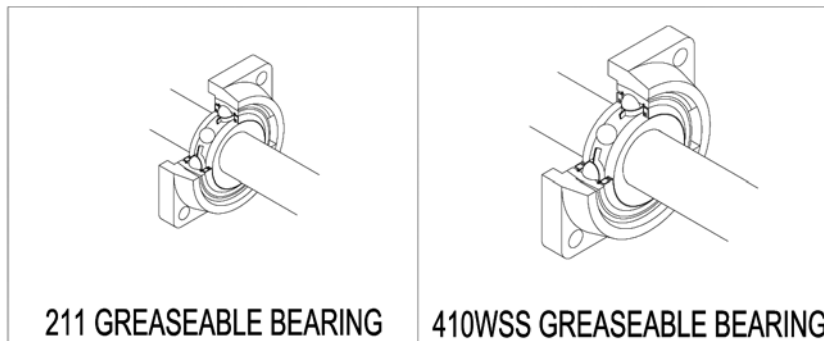

Assembly Instructions

fig 16 - need a drawing to go here

1. See Fig 16. Raise main frame, arrow 1, approximately 46" (1168mm) from ground and block securely.
2. See Fig. 16 & 17. Fasten main frame rockshaft, arrow 2, to bottom of main frame using three (3) cast rockshaft bearings, arrow 3, 4 and 5. Secure with (2) 3/4" x 6-1/2" (19mm x 165mm) bolts for each bearing. Install top half of rockshaft bearings so grease hole faces rear. Install bottom half of rockshaft bearings so grease holes faces front. Position rockshaft so that centre bearing is located between cleats welded to rockshaft. Lubricate bearings with grease before installing rockshaft in bearings.
3. See Fig. 16. Install four (4) six bolt hub and spindle assemblies, arrow 6, into tube holdings at bottom of rockshaft wheel legs. Fasten each spindle to the tube with one (1) 1/2" x 3-1/2" (12.7mm x 88.9mm) NC hex bolt complete with 1/2" (12.7mm) nylon locknut.
4. See Fig. 16. Install one six bolt tire and wheel assembly, arrow 7, to hub assembly, arrow 6, on each side of each wheel leg. Centre frame uses 11 L x 15 FI load range front tires. Secure with six (6) 9/16" x 1 1/8" (14.9mm x 28.6mm) wheel bolts, arrow 8. Tighten wheel bolts to 130 ft. lbs. (18m/kgs).

NOTE: Wheel bolts must be kept tight. If bolts are not tight they will loosen causing severe damage to hub, wheel tire, Check wheel bolts periodically, especially th first few hours of operation, either transport or field work.



WARNING

Support main frame securely before assembling components. Inadequate support may result in the heavy components falling and causing serious injury to you or person(s) nearby



CAUTION

When assembling disc use aligning punch to line up holes. Keep fingers out of holes.

5. See FIG. 16. Fasten 4 gang beam extension (12" (305mm) long), arrow 8, to plates welded to frame. Fasten each extension with (4) 3/4" x 2-1/2" (19mm x 63.5mm) bolts. Use necessary 1-1/2" x 1-1/2" (38.1mm x 38.1mm) shim plates to align and level extension with 4" x 4" (101.6mm x 101.6mm) beams welded on main frame.

fig 18 - Need a drawing to go here

6. See FIG. 18. Attach hitch assembly, arrow 1, to hitch lugs on main frame with two (2) 1-1/4" (31.8mm) diameter pins. Secure pins with two (2) 5/16" x 1-3/4" (8mm x 44.5mm) cotter pins.
7. See FIG.18. To attach levelling arm, arrow 2, to levelling arm, arrow 3, remove bolt on lug, arrow 4, of hitch levelling arm. Next install 1" (25.4mm) diameter pin on bearing tube, arrow 5, into weld on lug, arrow 6, of levelling arm. Position retaining tube so grease fitting is facing up. Place bottom lug, arrow 4, over outside of levelling arm. Install 1" (25.4mm) diameter pin of retaining tube into bolt on lug. Fasten the bottom lug to levelling arm with four (4) 1/2" x 5" (12.7mm x 127mm) NC hex bolts comes with nuts and lock washers.
8. See FIG. 18. Attach clevis end of levelling link, arrow 2, to arm, arrow 7, on main frame rockshaft. Fasten with one (1) 1- 1/4" x 4-3/4" (31.8mm x 121mm) bolt c/w nut and lockwasher.

NOTE: The 1-1/4" x 4-3/4" (31.7mm x 170.6 mm) bolt must be tight so that the clevis is drawn up tight against the ball joint in arm, arrow 7. Tighten bolt to 840 ft lbs. Ball must be free to pivot in socket. Lubricate ball with oil and turn in socket to make sure ball is free to pivot.

**CAUTION**

Use adequate manpower or a hoist to lift heavy components into place. Attempting to lift heavy components by yourself could cause serious injury.

9. See FIG. 18. Fasten hose support, arrow 8, to a bolt welded to top of hitch. Secure with one (1) 5/8" (15.7mm) nut, one (1) 11/16" (17.2 mm) ID flatwasher, and one (1) 5/8" (15.7 mm) lockwasher.
10. See FIG. 18. Mount hitch jack, arrow 9, mount jack on round tube welded to inside of hitch. Jack pivots on mounting tube and can be placed in a vertical position for supporting disc hitch or horizontal position while disc is in motion. Lock jack in desired position with pin.

NOTE: Jack must be in horizontal position when disc is in motion. If jack is in vertical position when disc is in motion, jack may strike ground or obstruction on ground, causing severe damage to jack. Be sure crank of jack is not hanging below hitch when jack is in horizontal position. Place crank on top of hitch to avoid damage.

11. See FIG. 18. Fasten one (1) wing frame hinge lug, arrow 10, to each 4 hole mount plate, arrow 11, located at front and rear corners on each side of main frame. Be sure to install the notched hinge lug on the front LHS mount plate, secure each hinge lug with four (4) 3/4" x 2-1/2" hex bolts c/w nuts and lockwashers.

fig 19 - Need a drawing to go here.

NOTE: Position rockshaft bearing set, arrow 7, so grease hole in top half from rear and grease hole in bottom half face front.

12. See Fig. 19. Before assembling wing frames, arrows 1 and 2, install grease fitting, arrow 4, in pivot bushings welded in front and rear hinge tubes of each wing frame.
13. **A** - See FIG. 19. Attach LH wing frame, arrow 1, to LH side of main frame and attach RH wing frame, arrow 2, to RH side of main frame. Fasten with (2) two 1-1/4" x 8" (31.8mm x 203mm) bolts, arrow 3, come with nuts and lock washers. Install bolts from front. Wing should not be free to move back and forth in hinge bracket. To take up slack, place shim(s), between hinge bracket and wing tube. DO NOT over tighten bolts causing hinge lugs to bend. Wing must be free to pivot. There are two (2) wing frame widths, narrow (68" (1727mm)) wide (96" (2438mm)). Models 23-1/2' to 32-1/2' (8.99m to 9.90m) use wide wing frames.

Model 4490 uses a narrow wing frame (65" wide) for the following models:

- 8" spacing - 86 and 94 blades
- 9" spacing - 78 and 86 blades
- 8" spacing - 70, 74 and 78 blades
- 9" spacing - 62, 66 and 70 blades

Model 4490 uses a wide wing frame (93") for the following models:

- 8" spacing - 86 and 94 blades
- 9" spacing - 78 and 86 blades
- 8" spacing - 70, 74 and 78 blades
- 9" spacing - 62, 64 and 70 blades

NOTE: To determine which is the proper wing frame for LH and RH side, see FIG. 19. LH wing frame has gang in front of front hinge bolt, arrow 2.

B - See FIG. 19. Fasten LH and RH wing rockshafts, arrows 4 and 5 to bottom of LH and RH wing frame. Be sure correct rockshaft is used. Wheel lug points towards rear with cylinder arm on top. Secure each rockshaft to two (2) bearing brackets, arrow 6, with two (2) sets of 5-1/2" (139.2 mm) rockshaft bearings, arrow 7, fasten each rockshaft bearing to bearing set to bearing bracket with two (2) 3/9" x 6-1/2" (19 mm x 6-1/2 mm) hex bolts come with nuts and lock washers. Position top half of rockshaft bearing so grease hole faces rear. Position bottom half of rockshaft bearing so grease hole faces front. After tightening rockshaft bearing bolts, rockshaft should be free to pivot in bearings.

NOTE: If rockshaft bearings are too tight and don't allow crankshaft to turn freely place necessary 2" x 3" (50.8 mm x 76.2 mm) shims, arrow 8, (as required) between bearing halves. Shim(s) are placed in hydraulic hose and fitting box.

NOTE: Before installing rockshaft bearings place a coat of grease on bearing surface.

Fig 20 - Need a draawing to go here.

14. See Fig. 20 and 21. Fasten RH wing rockshafts, arrow 1, to bottom of RH wing frame. Be sure correct rockshaft is used. Wheel legs, arrow 6, should point towards front with cylinder arm pointing up. Secure each rockshaft to wing frame with two (2) cast rockshaft bearings, arrows 2. Position top half of rockshaft bearing so grease hole faces rear. Position bottom half of rockshaft bearing so grease hole faces front. Secure each bearing with (2) 3/4" x 6-1/2" (19mm x 165mm) hex bolts. Coat bearings with grease before assembling.
15. See FIG. 19. Install one grease fitting, arrow 9, in top and bottom halves of rockshaft bearings, arrow 9.
16. See FIG. 19. Install one grease fitting, arrow 10, in pivot bushing welded in front and rear hinge tubes of each wing frame.
17. Attach hub assembly to wing rockshafts.

A - Dual wheels - see FIG.19. Install one (1) .6 bolt hub and spindle assembly, arrows 11 and 12, in each end of mount tube welded to wheel legs, arrow 13. Secure each spindle with one (1) 1/2" x 3-1/2" (12.7mm x 88.9mm) hex bolt complete with nylon locknut.

B - Single wheels - See FIG.19. Install one (1) only 6 bolt hub and spindle assembly, arrow 11, in outside end of mount tube welded to wheel legs, arrow 13. Secure spindle with one (1) 1/2" x 3-1/2" (12.7mm x 88.9 mm) hex bolt complete with nylon locknut.

18. See FIG.19. Install one (1) wheel and tire assembly, arrow 14, to each hub assembly. Secure with six (6) 9/16" x 1-1/8" (19.3 mm x 28.6 mm) wheel bolts, arrow 5. Tighten wheel bolts to 130 ft lbs (18 m kgs).

NOTE: Wheel bolts must be kept tight. If bolts are not tight they will loosen causing severe damage to hub, wheel, and tire. Check wheel bolts periodically, especially the first few hours of operation, either transport or field work.

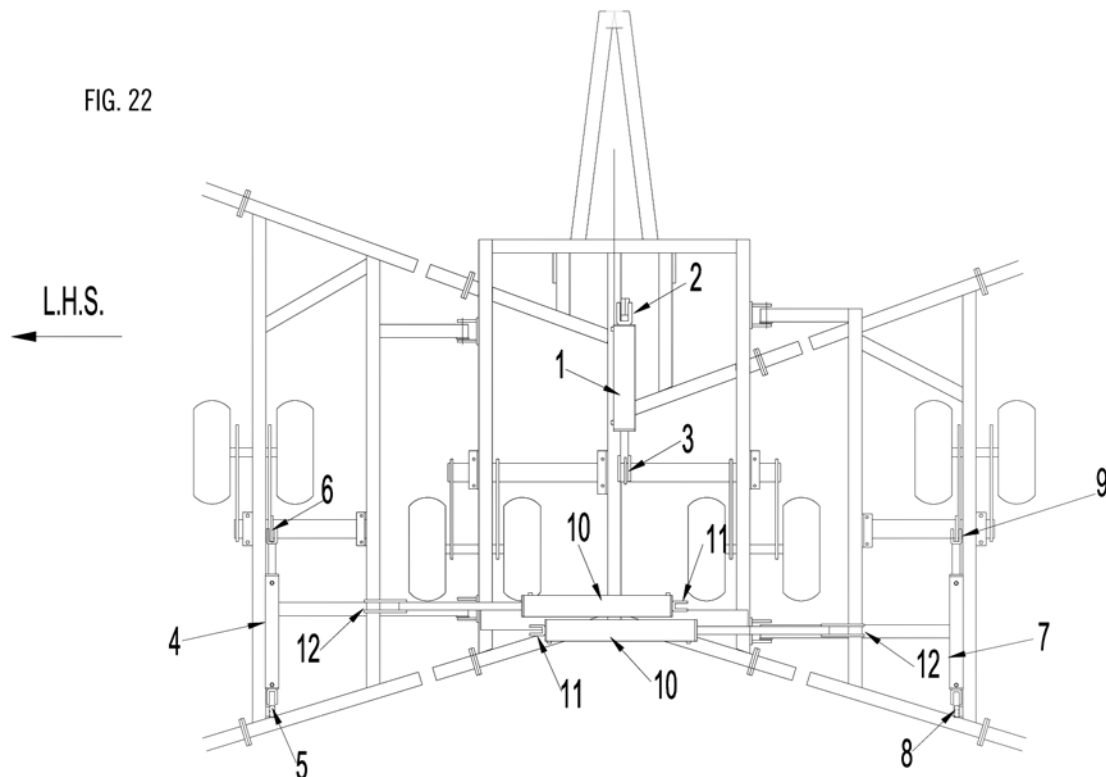

19. See FIG.22. Fasten one (1) 4" x 24" (101.6 mm x 610 mm) lift cylinder , arrow 1, to main frame and rockshaft arm. Fasten barrel end to cylinder lug, arrow 2. Position so ports face LHS. Fasten shaft end to cylinder arm, arrow 3, on rockshaft. Fasten each end of cylinder with one (1) 1-1/4" x 4-3/16" (31.7 mm x 106.4 mm) pin. Secure cylinder pins with one (1) 5/16" x 2" (7.9 mm x 50.8 mm) cotter pin.
20. See FIG.22. Fasten one (1) 3-1/2 x 24" (88.9 mm x 610 mm) rockshaft cylinder, arrow 4, to L.H. wing frame and rockshaft arm. Fasten barrel end end to 1-1/4 x 8" (31.7 mm x 203 mm) I-bolt, arrow 5. Position so ports face up. Fasten shaft end to cylinder arm, arrow 6, on rockshaft. Fasten each end of cylinder with one (1) 1-1/4" x 4-3/16" (31.7 mm x 106.4 mm) clevis pin. Secure pins with one (1) 5/16" x 2" (7.9 mm x 50.8 mm) cotter pin.
21. See FIG. 22. Fasten one (1) 3" x 24" (76.2 mm x 610 mm) rockshaft cylinder, arrow 7, to RH wing frame and rockshaft arm. Fasten barrel end to 1-1/4" x 8" (31.7 mm x 203 mm) I-bolt, arrow 8. Position so ports face up. Fasten shaft end to cylinder arm, arrow 9, on rockshaft. Fasten each end of cylinder with one (1) 1-1/4" x 4-3/16" (31.7 mm x 106.4 mm) clevis pin. Secure cylinder pin with one (1) 5/16" x 2" (7.9 mm x 50.8 mm) cotter pin.

NOTE: If cylinder pin on barrel end is not positioned properly, serious damage may occur to cylinder or I-bolt. If cylinder barrel is turning so axis of cylinder pin is not horizontal, cylinder will not be free to pivot up and down when cylinder is actuated.

22. See FIG. 22. Fasten (2) 5" x 36" wing lift cylinders, arrow 10, to cylinder lugs on rear tube of main frame. Position front cylinder with ports facing the front and rear cylinder with ports facing the rear of disc. Fasten barrel end of each cylinder to lug, arrow 11, with one (1) 1-1/4" x 4-3/16" (31.7 mm x 106.4 mm) clevis pin. Secure each pin with one (1) 5/16" x 2" (7.9 mm x 50.8 mm) cotter pins. Do not attach shafts at this time.
23. See Fig. 23. Place two (2) hydraulic lockup valves, arrow 1 and 2, in bracket, arrow 3, welded to front centre of main frame. Valves are assembled LH and RH. Position valves as shown so handle moves out when closing valve (as shown) and forward when opening valves. Position valves between front and rear holes in bracket, arrow 3, then installing (2) 1/4" x 4" (6.35mm x 101.6mm) NC hex bolts c/w nuts and lockwashers in bracket to hold valves in place.

FIG. 23

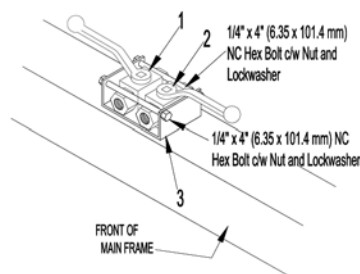

Hydraulic System

FIG. 24

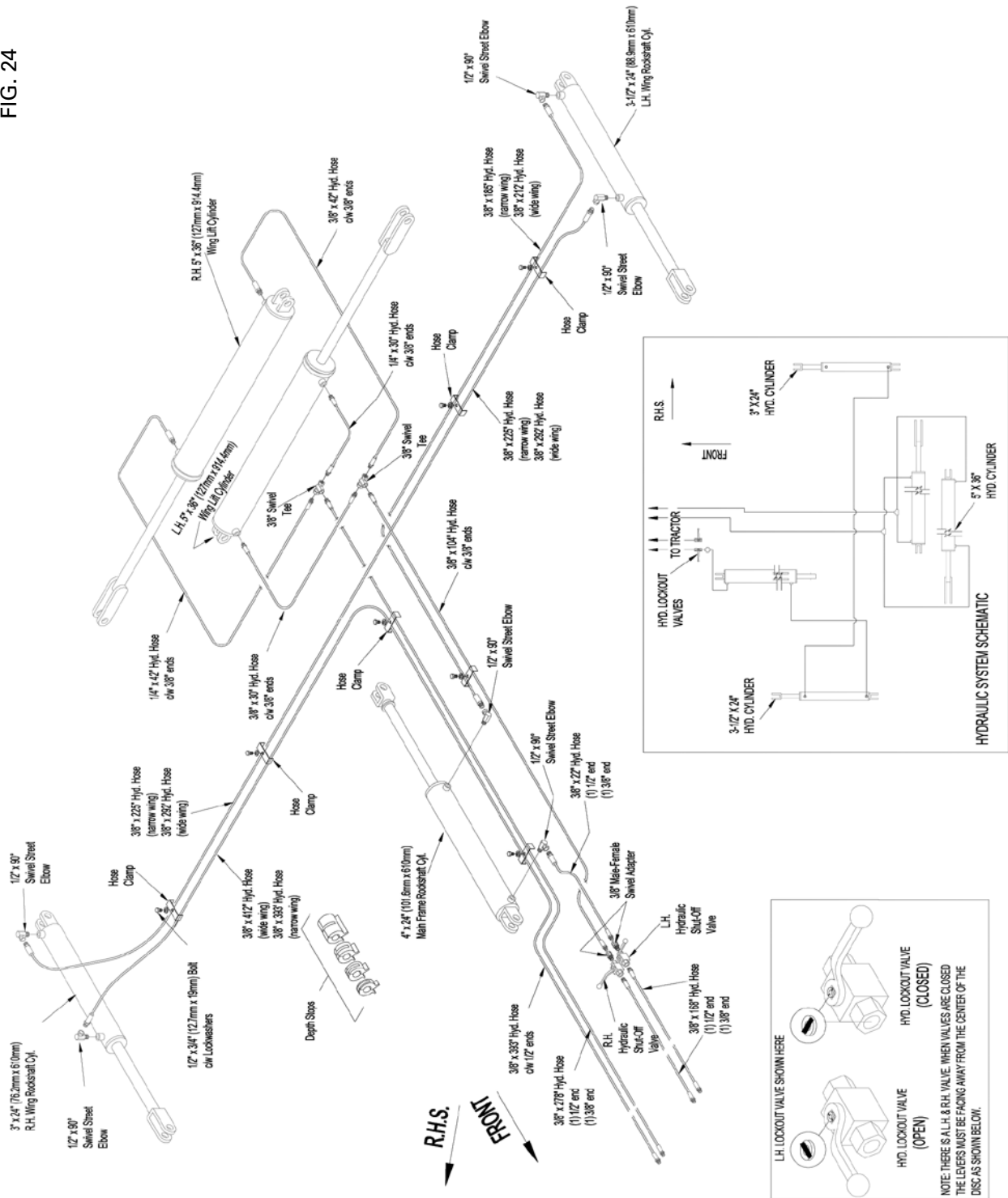

24. Attaching hydraulic hoses to rockshaft cylinders and wing lift cylinders.

NOTE: Do not use teflon tape to seal hydraulic hoses and fittings. If piece of tape gets into the hydraulic system they may plug small orifices.

NOTE: To ensure the hydraulic system does not leak, seal the fittings and hoses with a sealing liquid.

- See FIG. 24. Install one (1) 1/2" x 90 degree (12.7 mm) swivel street elbow in the shaft end port of the R.H. 3" x 24" (76.2 mm x 610 mm) wing rockshaft cylinder. **NARROW WING-** Connect one (1) 3/8" x 393" (9.39 mm x 9982 mm) hydraulic hose to same swivel street elbow. **WIDE WING-** Connect one (1) 3/8" x 412" (9.39mm x 10465mm) hydraulic hose to same swivel street elbow. Then run the hose across the wing frame to the centre of the main frame, and to front of hitch.
- See FIG. 24. Install one (1) 1/2" x 90 degree (12.7 mm) swivel street elbow in shaft end, port of 3-1/2" x 24" (88.9 mm x 610 mm) LH wing rockshaft cylinder. Install one (1) 1/2" x 90 degree (12.7 mm) swivel street elbow, in the barrel end port of the RH 3" x 24" (76 mm x 610 mm) wing rockshaft cylinder. **NARROW WING-** Connect one (1) 3/8" x 225" (9.39 mm x 5715 mm) hydraulic hose to swivel elbow on RH cylinder. **WIDE WING-** Connect one (1) 3/8" x 292" (9.39mm x 7497mm) hydraulic hose to swivel elbow on RH cylinder. Next run hose across frame to 1/2" x 90 degree (12.7 mm) swivel elbow on shaft end port of LH cylinder.
- See FIG. 24. Install one (1) 1/2" x 90 degree (12.7 mm) swivel street elbow to barrel end port of LH 3-1/2" x 24" (88.9 mm x 610 mm) wing rockshaft cylinder. Install one (1) 1/2" x 90 degree (12.7 mm) swivel street elbow, to shaft end port of 4" x 24" (101.6 mm x 610 mm) main frame cylinder. **NARROW WING-** Connect one (1) 3/8" x 185" (9.39 mm x 4699 mm) hydraulic hose to swivel elbow on shaft end port of main frame cylinder. **WIDE WING-** Connect one (1) 3/8" x 212" (9.39mm x 5385mm) hydraulic hose to swivel elbow on shaft end port of main cylinder. Next run same hose across frame to 1/2" x 90 degree (12.7 mm) swivel elbow on barrel end port of LH 3-1/2" x 24" (88.9 mm x 610 mm) wing rockshaft cylinder.
- See FIG. 24. Install one (1) 1/2" x 90 degree (12.7 mm) swivel street elbow into the barrel end port of 4" x 24" (101.6 mm x 610 mm) main frame cylinder. Connect one (1) 3/8" x 24" (9.39 mm x 610 mm) hydraulic hose, to rear port of RH lock-up valve, with one (1) 3/8" (9.39 mm) male-female swivel. Next connect same hose to 1/2" x 90 degree (12.7 mm) swivel elbow, on front port of main frame cylinder.
- See FIG. 24. Install one (1) 3/8" (9.39 mm) male x 3/8" (9.39 mm) male union in the barrel end port of the LH 5" x 26" (127 mm x 660 mm) wing lift cylinder. Then install one (1) 3/8" x 3/8" x 3/8" (9.39 mm x 9.39 mm x 9.39 mm) tee, to the 3/8" (9.39 mm) union. Install one (1) 3/8" x 90 degree (9.39 mm) street elbow, into the shaft end of LH 5" x 36" (127 mm x 914 mm) wing lift cylinder.
- See FIG. 24. Install one (1) 1/4" x 30" (6.35 mm x 762 mm) hydraulic hose to the shaft end port of the LH 5" x 36" (127 mm x 914 mm) wing lift cylinder then fasten opposite end to one (1) 3/8" (9.39 mm) swivel tee. Fasten one (1) 1/4" x 42" (6.35 mm x 1067 mm) hydraulic hose to the shaft end port of the RH 5" x 36" (127 mm x 914 mm) wing lift cylinder and fasten opposite end to same 3/8" (9.39 mm) swivel tee.
- See FIG. 24. Install one (1) 3/8" (9.39 mm) male x 3/8" (9.39 mm) female swivel adapter, in to the L.H. lockup valve. Fasten one (1) 3/8" x 100" (9.39 mm x 2540 mm) hydraulic hose, in 3/8" (9.39 mm) swivel tee (connects hoses to barrel end ports of 5" x 36" cylinders). Fasten opposite end of same hose to the 3/8" (9.39 mm) male x 3/8" (9.39 mm) female swivel adaptor in RH lockup valve.
- See FIG. 24. Install two (2) 3/8" x 168" (9.39 mm x 4267 mm) hydraulic hoses to the front port of hydraulic lockup valves, and run hoses to front of hitch.

- See FIG. 24. Install one (1) 3/8" x 278" (9.39 mm x 7061 mm) hydraulic hose to the 3/8" (9.39 mm) swivel tee (connects hoses to shaft end ports of 5" x 36" cylinders) to front of hitch.
25. Securing hydraulic hoses to frame - see FIG. 24 - Fasten hoses to frame with one U-shaped hose clamp at each hose hold down point. Each hold down point has a 1/2" (12.7 mm) hex nut welded to the top of frame. The hold down clips are supplied in two widths, one for two hoses and one for three hoses. Place hose clamp over hoses and fasten clamp to weld-on nut with one 1/2" x 3/4" (12.7 mm x 19.0 mm) bolt c/w lockwasher.
 26. How main lift rockshaft hydraulic system works - see FIG. 24 - When raising the disc, oil is pumped into the barrel end port of 4" x 24" (101.6mm x 610mm) centre frame cylinder causing the cylinder to extend. Oil is then forced from the shaft end port of same cylinder into the barrel end port of the 3-1/2" x 24" (88.9 mm x 610 mm) cylinder on LH side causing wing cylinder to extend. Oil is then forced from the shaft end port of the 3-1/2" x 24" (88.9 mm x 610 mm) cylinder into the piston end port of the 3" x 24" (76.2 mm x 610 mm) wing cylinder on RHS causing wing cylinders to extend. The oil from shaft end port of the 3" x 24" (76.2 mm x 610 mm) cylinder on RHS is returned to the tractor.

When lowering disc, oil flows from tractor to shaft end port of the 3" x 24" (76.2 mm x 610 mm) wing cylinder, causing wing cylinder to contract. Oil forced from piston end port of the 3" x 24" (76.2 mm x 610 mm) wing cylinder flows to shaft end port of LH 3-1/2" x 24" (88.9 mm x 610 mm) cylinder, causing cylinder to contract. The oil forced from the piston end port of the LH 3-1/2" x 24" (88.9 mm x 610 mm) wing cylinder flows to shaft end port of main frame 4" x 24" (101.6 mm x 610 mm) cylinder causing cylinder to contract. The oil from piston end port of the 4" x 24" (101.6 mm x 610 mm) cylinder is returned to the tractor.

NOTE: Lockup valve must be open to allow oil to flow to and from lift cylinders.

All cylinders extend and contract at the same rate because the amount of oil flowing between the shaft end ports and the piston end ports is equal in volume. For example, the 4" x 24" (101.6 mm x 610 mm) main frame cylinder has a 2" (50.8 mm) diameter piston shaft which displaces enough oil from the shaft side to fully extend the 3-1/2" x 24" (88.9 mm x 610 mm) L.H. wing cylinder. The same method is used between the 3-1/2" x 24" (88.9 mm x 610 mm) L.H. wing cylinder and the 3" x 24" (76.2 mm x 610 mm) R.H. wing cylinder. Each lift (rockshaft) cylinder contains a by-pass to allow oil to flow past piston when each cylinder is fully extended. If all cylinders are not fully extended when disc is raised, continue to pump oil into lift cylinders until all cylinders are fully extended.

27. **NOTE:** Before filling lift cylinders with oil, remove clevis pin from shaft end of each cylinder so that the cylinders may be extended and contracted without actuating rockshafts. Support cylinders so shafts pass over rockshaft arms and frame components.

See FIG. 24 - To fill rockshaft cylinders with oil remove depth control stops to allow cylinders to work full length of stroke. Next, pump oil into the cylinders working shafts in and out. After all cylinders have been completely filled with oil, synchronize cylinders by fully extending them. After the first cylinder is fully extended continue to hold hydraulic lever until the other two (2) cylinders are all fully extended. Attach shaft end of each cylinder to rockshaft arm with one (1) 1-1/4" x 4-3/4" (31.7 mm x 121 mm) pin. Secure each pin with two (2) 5/16" x 1-3/4" (7.57 mm x 44.4 mm) cotter pins.

28. **NOTE:** Before filling wing cylinders with oil, support cylinder so shaft passes over cylinder lug on wing.

See FIG. 24. Pump oil into all 5" x 36" (127 mm x 914 mm) wing cylinders. Extend and contract cylinder shafts until cylinders are completely filled with oil. After cylinders are full of oil, fully extend all of them. Next, attach shaft end of each cylinder to a slotted hole in lug on wing frame with one (1) 1-1/4" x 4-3/4" (31.7 mm x 121 mm) pin. Secure each pin with two (2) 5/16" x 1-3/4" (7.87 mm x 44.4 mm) cotter pins.



CAUTION

Hydraulic cylinders can be seriously damaged if clevis of shaft strikes rockshaft arm or wing cylinder lug as cylinders are being cycled to fill them with oil.



CAUTION

If hydraulic cylinder shafts are unpinned and cycled to fill them with oil, they can be seriously damaged if clevis of shaft strikes rockshaft arm or wing cylinder lug.



CAUTION

Do not disconnect hydraulically operating components when there is pressure within those components. Hydraulic components under pressure may cause parts and hydraulic fluid to fly out at a high velocity which could cause serious injury.



CAUTION

Hydraulic oil escaping under pressure has sufficient force to cause serious injury. If injured by escaping fluid, obtain medical treatment immediately. Check hydraulic hoses periodically for signs of rupture and leaks. Use a card board as a backstop to check for escaping high pressure or hot fluid.



CAUTION

Wings will free fall if wing cylinders are not full of oil, causing serious damage or serious injury or death to person(s) nearby.



CAUTION

To assemble balance of disc, extend main lift cylinders raising frame. Be sure main lift cylinders are completely filled with oil. Then place adequate support under each main frame and wing frames. Do not use lock out valve as safety device to prevent frame from falling. If hydraulic hose(s) or fittings failed disc could drop causing serious injury or death to person(s) nearby.



CAUTION

Do not stand under wings while wings are being raised or lowered. If any components of hydraulic system should fail or if hydraulic lever should accidentally be operated, wings could drop causing serious injury or death.

29. Attaching gang beam extensions - see FIG. 25

NOTE: See gang beam chart to determine gang beam lengths for the size of your disc.

A - Front gang - Clamp front gang beams, arrow 1, to attaching plates that are welded to wing frame with (4) 3/4" x 2-1/2" (19mm x 254mm) bolts c/w nuts and lockwashers.

B - Rear gang - Clamp rear gang beams, arrow 2, to attaching plates that are welded to wing frame with (4) 3/4" x 2-1/2" (19mm x 254mm) bolts c/w nuts and lockwashers.

NOTE: Use necessary 1" x 1" (25.4mm x 254mm) shim plates to align and level each beam extension. See FIG. 25.



CAUTION

To prevent serious injury or death from falling frames, always place adequate supports under all three frames.

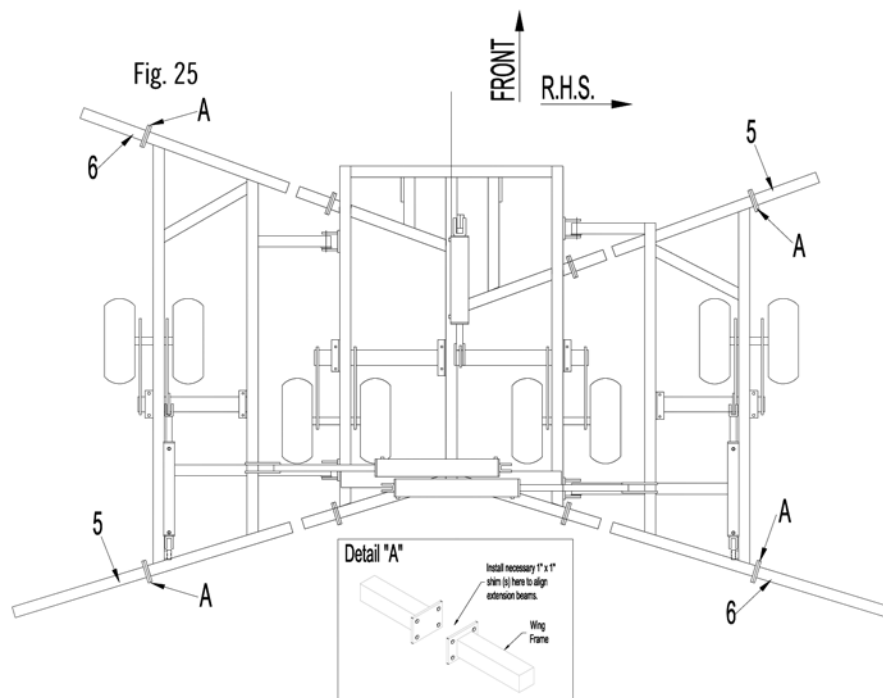
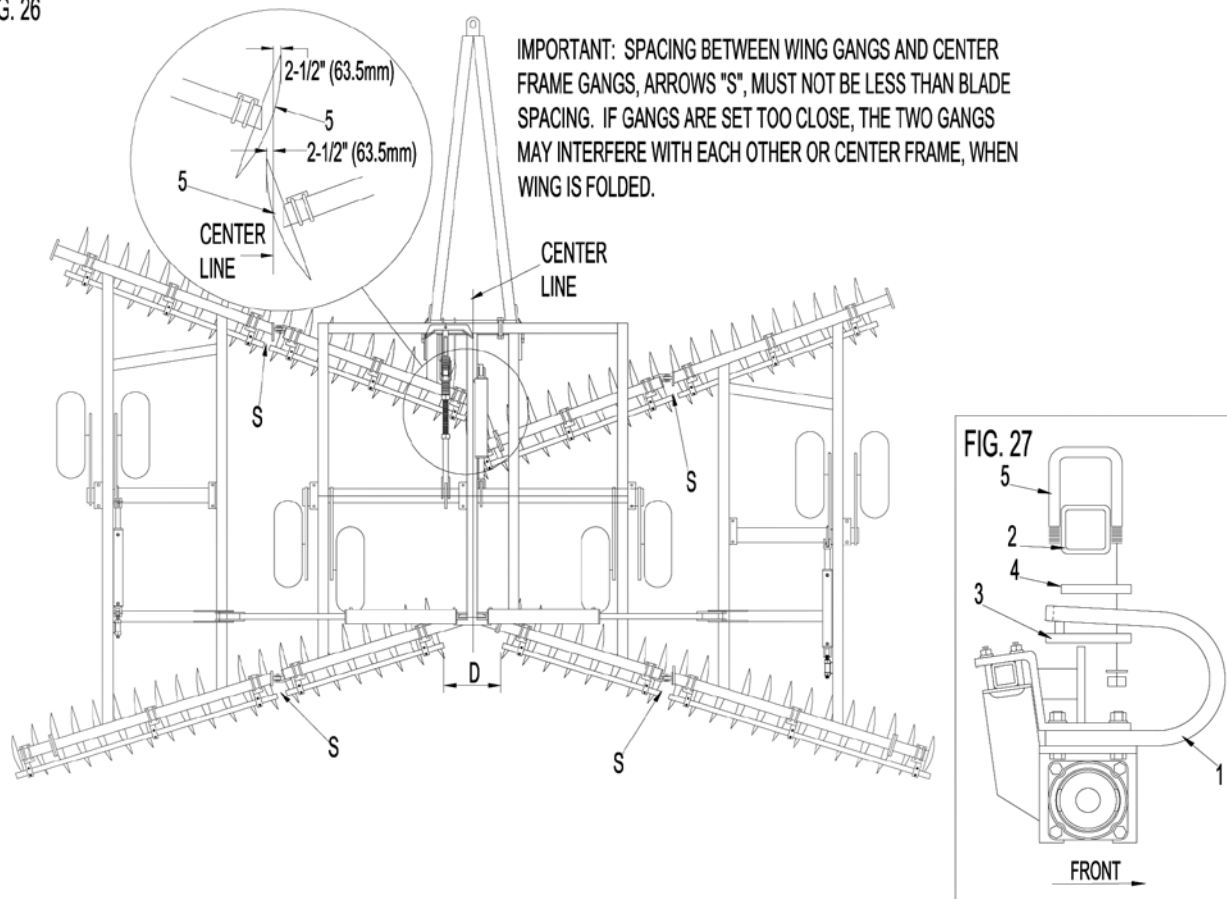

FIG. 26



30. Attaching gang assemblies - See FIG. 26

A - Rear gangs - Roll rear gang assemblies in place under rear gang beams. Position rear gangs so that the scrapers are at the rear. The gang assemblies with outrigger blades (small diameter blades) must be positioned at the outside. See FIG. 26. for the direction rear gangs face.

Attach bearing hangers to gang beams with two U-bolts per bearing hanger. Leave U-bolt loose. If disc is equipped with optional spring bearing hangers, see step (c) to attach hangers.

B - Front gangs - Roll front gang assemblies in place under front gang beams. Position gang assemblies so that the scrapers are at the rear. See FIG. 26 for the direction the front gangs face. Attach bearing hangers to gang beams with two U-bolts per bearing hanger. Leave u-bolts loose. If disc is equipped with optional spring bearing hangers, see step (c) to attach hangers.

NOTE: See FIG. 27. Optional stone flex bearing hangers - Fasten each hanger assembly, arrow 1, to bottom of gang beam, arrow 2, with one (1) backing plate, arrow 3, one (1) 1/4" x 4-1/2" x 4-1/2" (6.3mm x 114mm x 114mm) bearing plate, arrow 4, and two (2) 3/4" x 4" x 7" (19.0 x 102 x 178mm) u-bolts, arrow 5. The bearing plate is placed between bottom of gang beam and top of shank. Be sure the pin on backing plate, arrow 3, is inserted in slot of shank. When installing u-bolts, be sure rear leg of each u-bolt is installed through a hole in rear of plate.

NOTE: The bearing plate, arrow 4, is required to reinforce mounting surface of gang beam.

C - See FIG. 26. Set front gangs so that the leading edge of the inside blade, arrow 5, is approximately 2-1/2" (63.5 mm) past centre of disc.

D - See FIG. 26. Adjust spacing between each front gang assemblies, arrow 5. This spacing should be the same as the blade spacing in the gang assemblies.

NOTE: Spacing between wing gangs and centre frame gangs, arrow S, must not be less than blade spacing. If gangs are set too close, they may interfere with each other or centre frame when wings are folded or flex.

E - See FIG. 26. Set rear gangs so that the distance between the rear edge of the two inside blades, dimension "D", is equal to 2" (50.8mm) less than blade diameter. For example, if your disc is equipped with 24" (610 mm) diameter blades, dimension "D" would be set at 22" (559mm). Be sure the rear gangs are centred on the frame.

F - See FIG. 26. Adjust spacing between rear gang assemblies, arrow 5. This spacing should be the same as the blade spacing in the gang assemblies.

G - Before tightening bearing hanger u-bolts, loosen u-bolts which fasten scraper bar to bearing hanger. Then check each bearing hanger to make sure hanger is sitting square under gang beam. Also be sure hanger is not turned to one side.

H - Next tighten u-bolts. For discs equipped with solid hangers, tighten u-bolt to 150 ft lbs (203.25 N.m). For discs equipped with stone flex hangers, tighten U-bolts to 260 ft lbs (352.3 N.m)

NOTE: If bearing hangers are not sitting square before tightening u-bolts, thrust will be built into the bearings and the life of bearings will be shortened.

31. **Very Important** - See FIG. 28 - Loosen all the bolts, arrow 1, which bolt the bearings to the hangers, arrow 2. Then turn the disc blades to allow the bearings to align themselves. Next tighten all the bolts. This will ensure proper bearing alignment, increasing bearing life.
32. See FIG. 29. Adjust scraper bar, arrow 1, and scrapers, arrow 2, of each gang so that each scraper blade is in contact with disc blade.

NOTE: Disc will require less horsepower to pull if scrapers are adjusted properly.

	<p>CAUTION</p>	<p>When attaching gang assemblies, wear protective gloves to help prevent injury from cutting edges of blades.</p>
---	-----------------------	--

FIG. 28

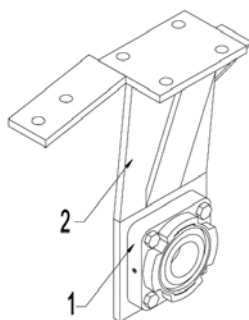

FIG. 29

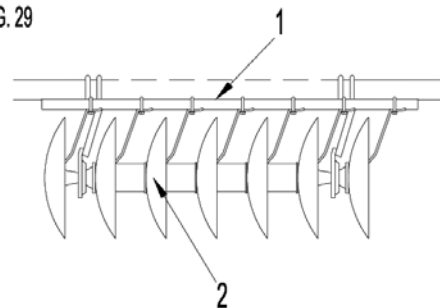

FIG. 30

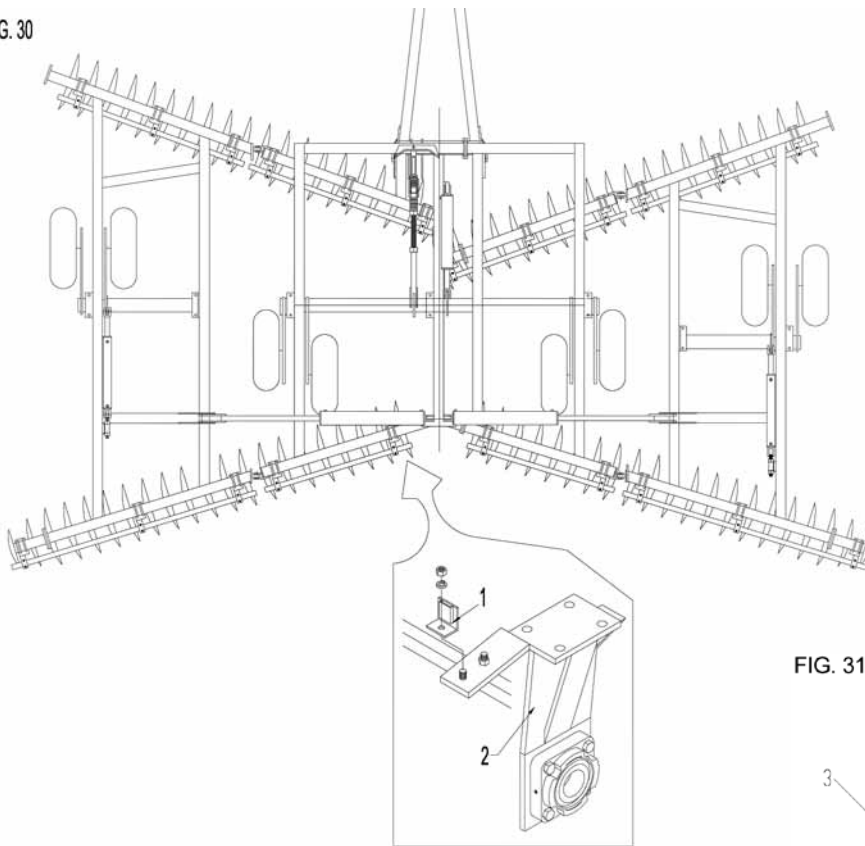
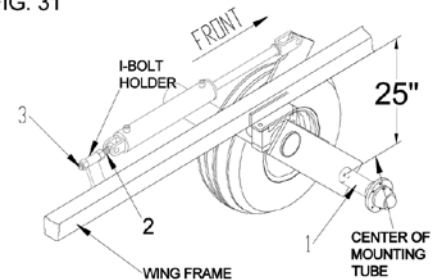

FIG. 31



33. See FIG. 30. Mount the SMV bracket, arrow 1, to the main frame's rear inside bearing hanger on the LH rear gang. Secure to the top of the scraper bar support with the same u-bolt used to fasten the scraper bar to the bearing hanger.

34. See FIG. 31. Level wing frame with main frame as follows:

- Raise disc by extending rockshaft cylinder. Be sure wing rockshaft cylinders are fully exterior.
- Check the distance the spindle mounting tube, arrow 1, (welded to bottom of rockshaft wheel leg) is from the bottom of each wing frame. This distance should be 25" (635mm).
- If spindle mounting tube location is not correct, adjust length of wing cylinder, I-bolt, arrow 2.
- After adjustment is complete, lock I-Bolt by tightening front nut, arrow 3, against I-bolt holder.

NOTE: The above wheel leg setting is an initial setting only. If wing gangs do not cut at same depth as the main frame gangs, further wing cylinder adjustment will be required.

NOTE: Be sure axis of barrel end pin is horizontal and cylinder points are facing up. If cylinder and I-bolt are not positioned. Properly cylinder will not be free to pivot when activated causing serious damage.

FIG 32

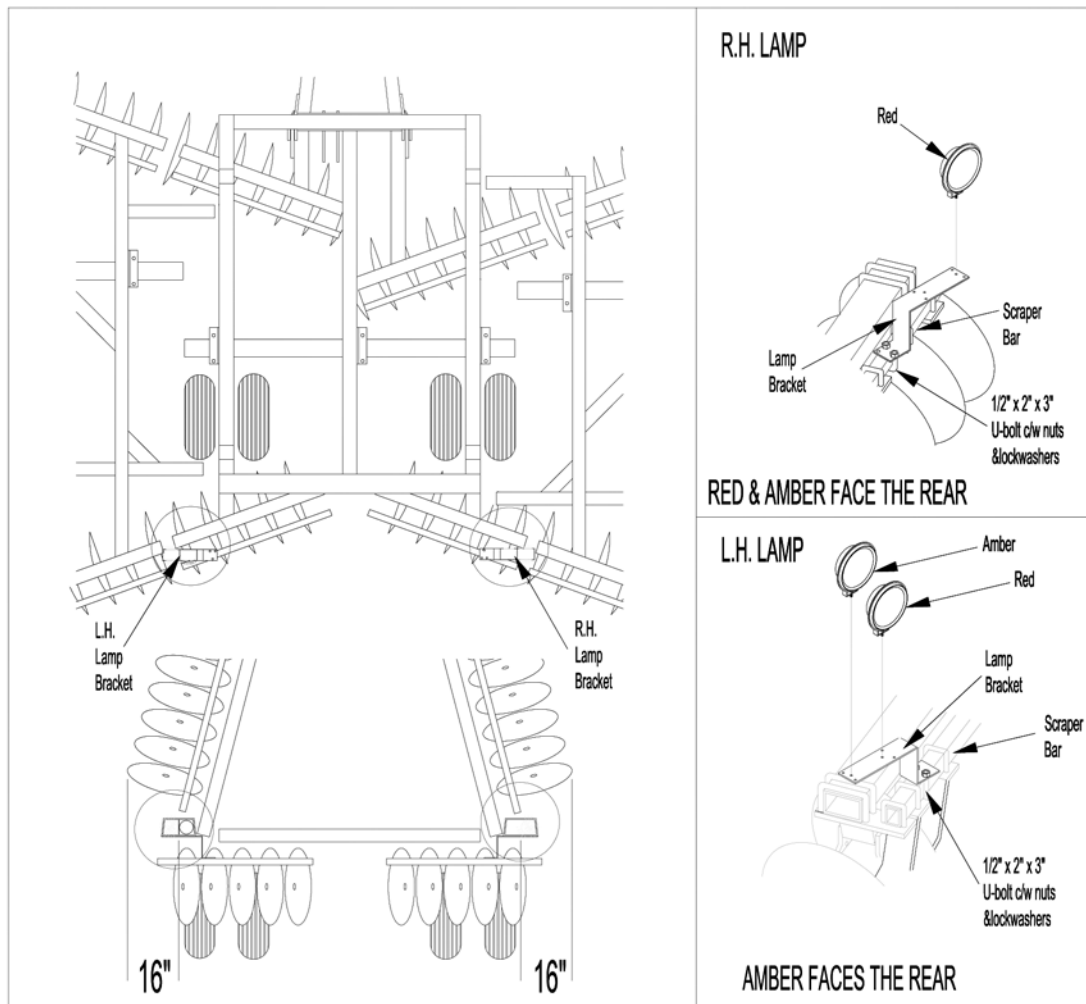

35. Warning light installation instructions (optional) - see FIG. 32

A - Fasten on lamp support bracket to each side of main frame. Locate on inside of 4" x 4" (101.6mm x 101.6mm) tube at rear of main frame. Fasten each support with tow (2) 1/2" x 7-1/2" (12.7mm x 190.5mm) hex bolt c/w nuts and lockwashers and one (1) backing plate.

B - Fasten one (1) mount plate to top of each lamp support bracket with one (1) 1/2" x 2" x 3" (12.7mm x 50.8mm x 76.2mm) u-bolt c/w nut and lockwasher. **DO NOT** tighten u-bolts at this time.

C - Fasten one(1) amber and one (1) red lamp to LH lamp support. Position so amber and red lamps face rear with the amber lamp on outside. Install lamps through 3/4" (19.1mm) holes in mount plate. Secure with nuts. Leave nuts loose on amber lamps so ring connector on wiring can be installed later.

D - Fasten one (1) amber lamp to RH lamp support. Position so amber faces rear. Install lamp through 3/4" (19.1mm) hole in mount plate. secure with nuts.

E - With disc folded into transport position lamps. Position LH dual lamps so the center line between the two (2) lamps is 9" (228.6mm) **INSIDE** the widest point of the disc. Position RH amber lamp so the center of lamp is 9" (228.6mm) inside the widest point of disc. Tighten mount plate u-bolts of both LH and RH assemblies.

NOTE: Paragraphs "b" and "c" and FIG. 32 describe and show lamp position for North American public roads. For other countries such as Australia, check local laws and regulations for required warning lamp mounting positions.

**CAUTION**

When transporting disc over public roads, use the smv emblem and warning light for protection of tractor and other motor vehicle operators. Check local laws for width and height maximums.

F - Install electrical wiring as follows:

F1 - See Fig. 33 – Run four (4) wire cables (brown, white, yellow, and green) from tractor socket receptacle to rear of disc. Split off green wire and run it to the RH amber lamp. Next, run white wire to amber lamp on LH side, then run yellow wire to LH amber lamp and run brown wire to red lamp on LH side. Strip wires and fasten ring connector to each wire. Install ring connector of each wire to threaded stem of each lamp as shown in FIG. 33. Tighten nut on each lamp.

F2 - Next, disassemble male plug, then insert all wires through spring end of male plug. Strip wires and insert each wire into specific terminal of outer half of male plug. Use FIG. 33 to match wire color to proper terminal number. Reassemble both halves of male plug.

F3 - Insert male plug into tractor' socket receptacle. Activate warning light switch and check if all lamps are flashing.

F4 - Important - Run wires along frame member. Do not run wires across open spaces. Wires that are run across open space will be damaged during discing operations or by people working on the disc.

F5 - Install a 1/2" ID x 9' (12.7mm x 2.74m) long plastic loom over wires that lead from male plug shown in FIG. 36. The plastic loom is installed by pushing the wires into the opening that runs the length of the loom.

FIG. 33

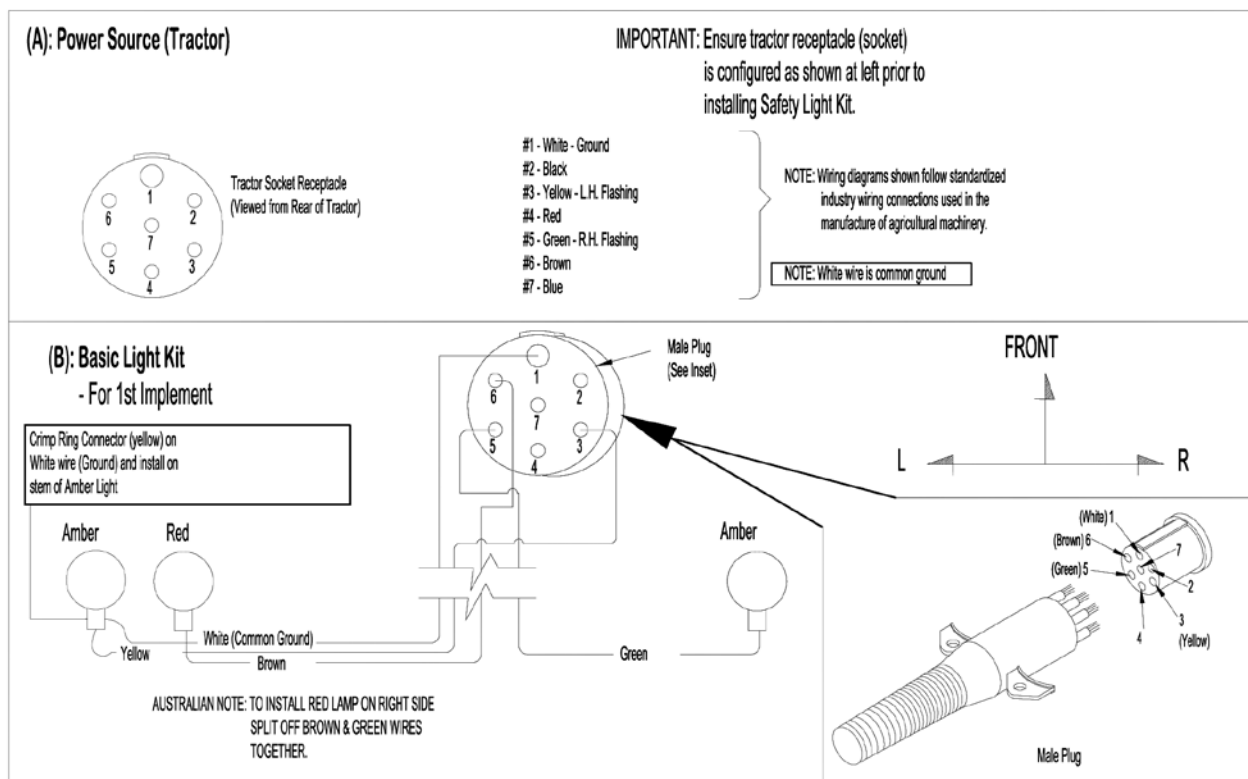

Components: Basic Light Kit

- 1 - 7 pin plug c/w 55 ft. (13.7m) 14/4 rib wire
- 3 - Nylon connectors (closed end)
- 2 - Lamps - amber both sides
- 1 - Lamp - red one side
- 10 - Cable ties
- 1 - Ground connector - ring type 7/16" - 1/2"
- 1 - 8' (24.4m) 1/2" plastic boom

Fig. 34

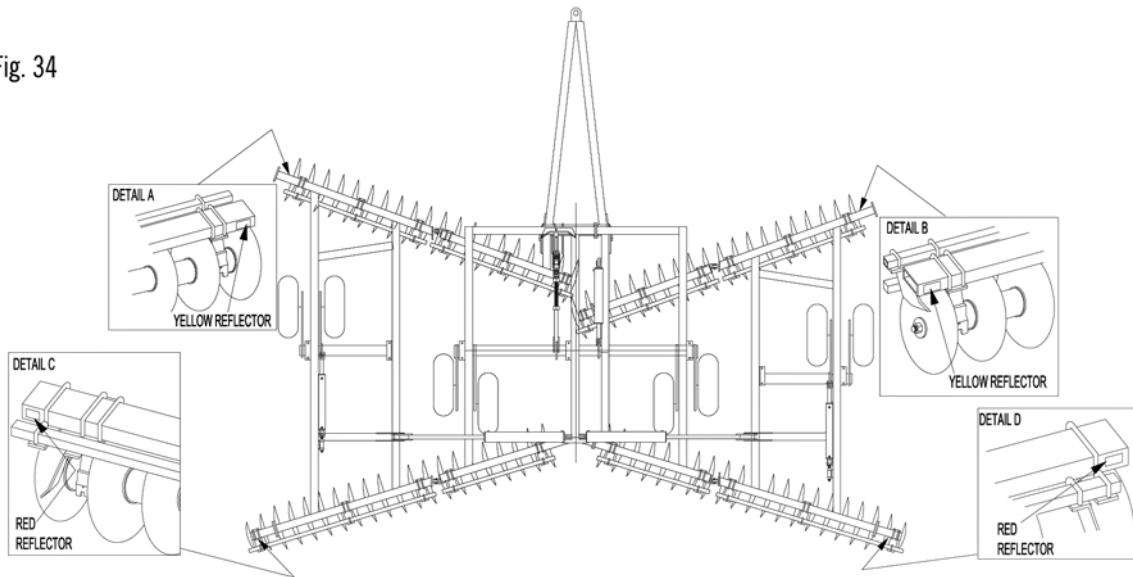

36. Reflector decal illustration - see FIG. 34

NOTE: Before installing decals, clean the area they will be placed on.

A - Place one 2" x 9" (50.8 x 228.6mm) red reflector decal on rear side of each rear gang beam. Locate decals approximately 1" (25.4mm) from end of gang beam. See detail "C" and "D".

B - Place one 2" x 9" (50.8 x 228.6mm) yellow reflector decal on front side of each front gang beam. Locate decals approximately 1" (25.4mm) from end of gang beam. See detail "A" and "B".

Wing Beam Extensions

Model	Front Extension Length	Rear Extension Length	Front Extension Length	Rear Extension Length
	8" Spacing		9" Spacing	
70B	16" Solid	42" Solid	-	-
74B	24" Solid	50" Solid	-	-
78B	36" Solid	58" Solid	-	-
86B	24" Solid	46" Solid	-	-
94B	36" Solid	66" Solid	-	-
62B	-	-	16" Solid	42" Solid
66B	-	-	24" Solid	50" Solid
70B	-	-	36" Solid	58" Solid
78B	-	-	24" Solid	46" Solid
86B	-	-	42" Solid	66" Solid

NOTE: Model 4490 uses a narrow wing frame (65" wide) for the following models:

8" spacing - 70, 74 and 78 blades

9" spacing - 62, 66 and 70 blades

NOTE: Model 4490 uses a wide wing frame (93" wide) for the following models:

8" spacing - 70, 74 and 78 blades

9" spacing - 62, 66 and 70 blades

Gang Pattern - 8" Spacing - 54 Blades/20 Bearings - Front

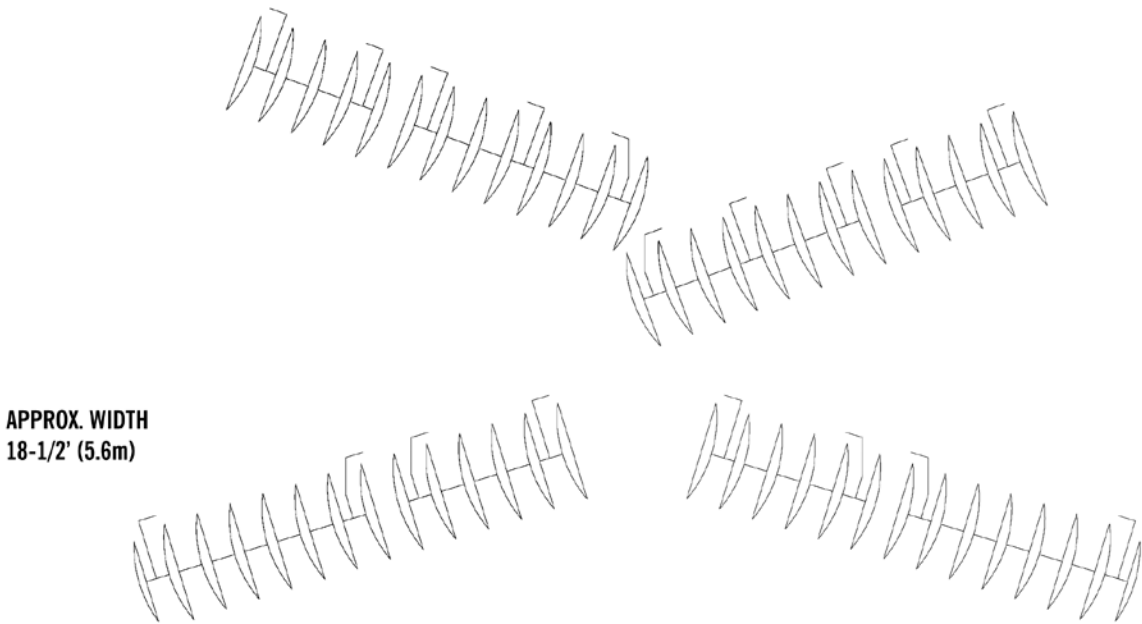

Gang Pattern - 8" Spacing - 58 Blades/20 Bearings - Front

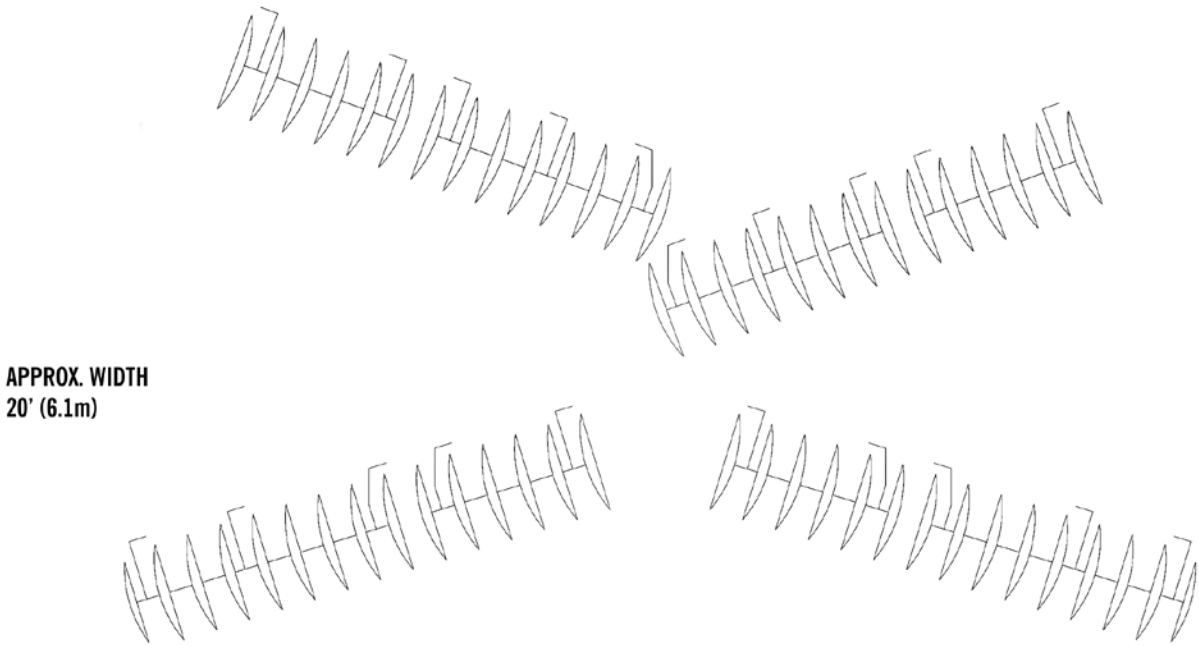

Gang Pattern - 8" Spacing - 62 Blades/20 Bearings - Front

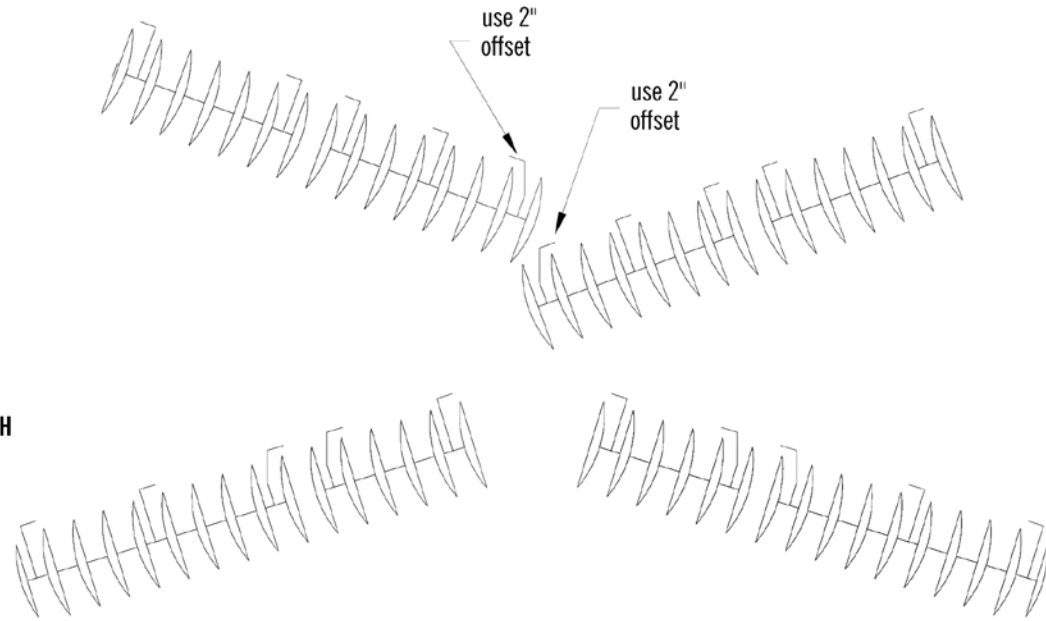

Gang Pattern - 8" Spacing - 70 Blades/22 Bearings - Front

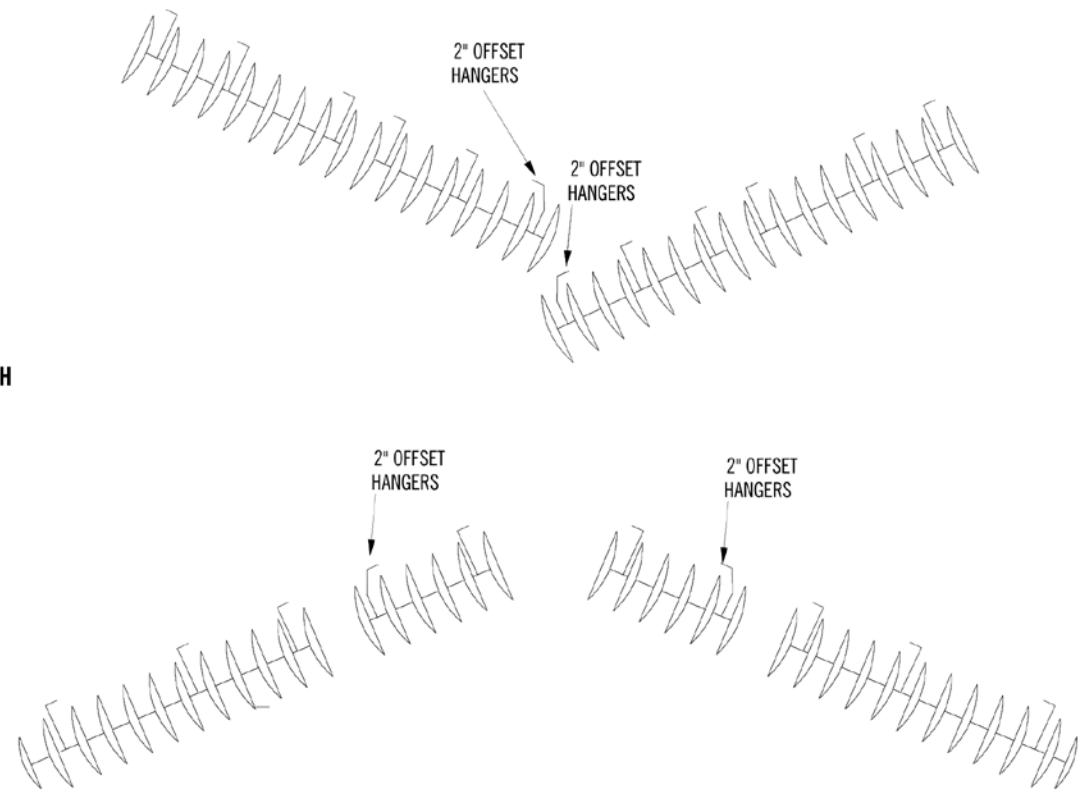

Gang Pattern - 8" Spacing - 74 Blades/22 Bearings - Front

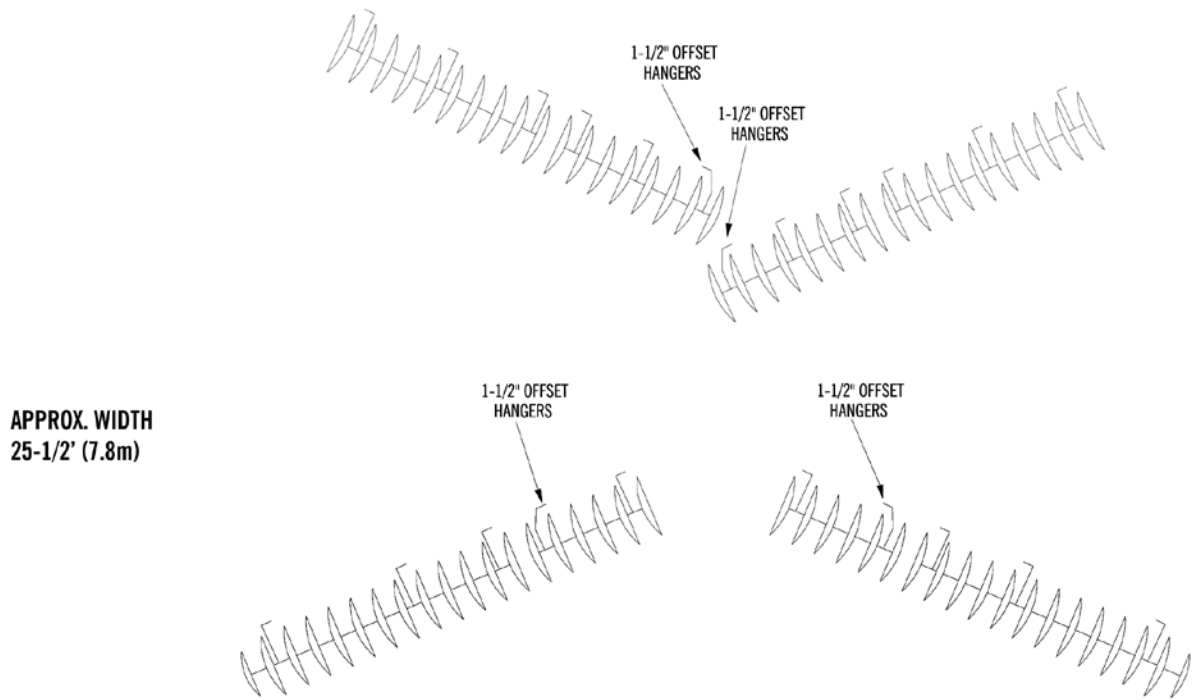

Gang Pattern - 8" Spacing - 74 Blades/24 Bearings - Front

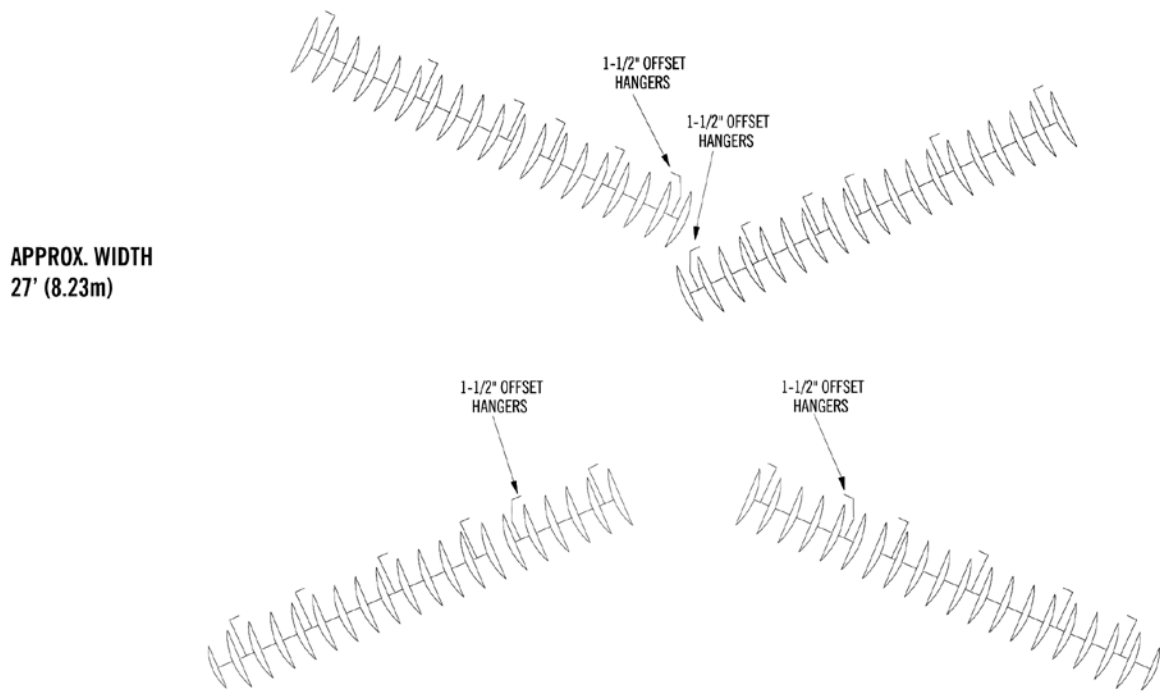

Gang Pattern - 8" Spacing - 86 Blades/24 Bearings - Front

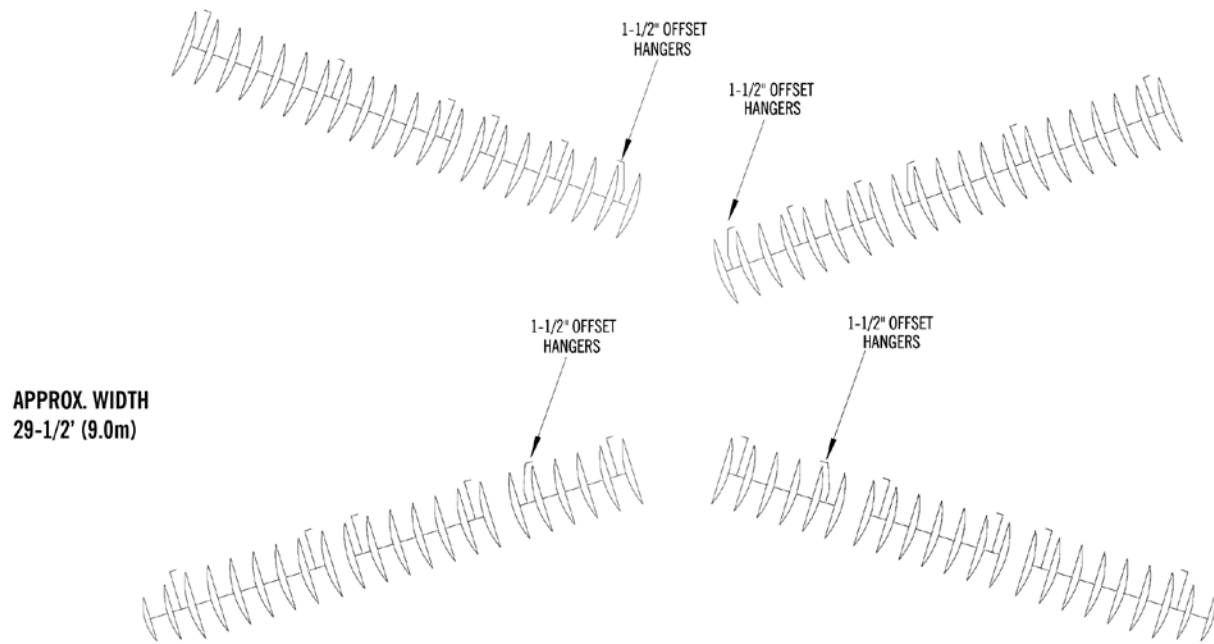

Gang Pattern - 8" Spacing - 94 Blades/28 Bearings - Front

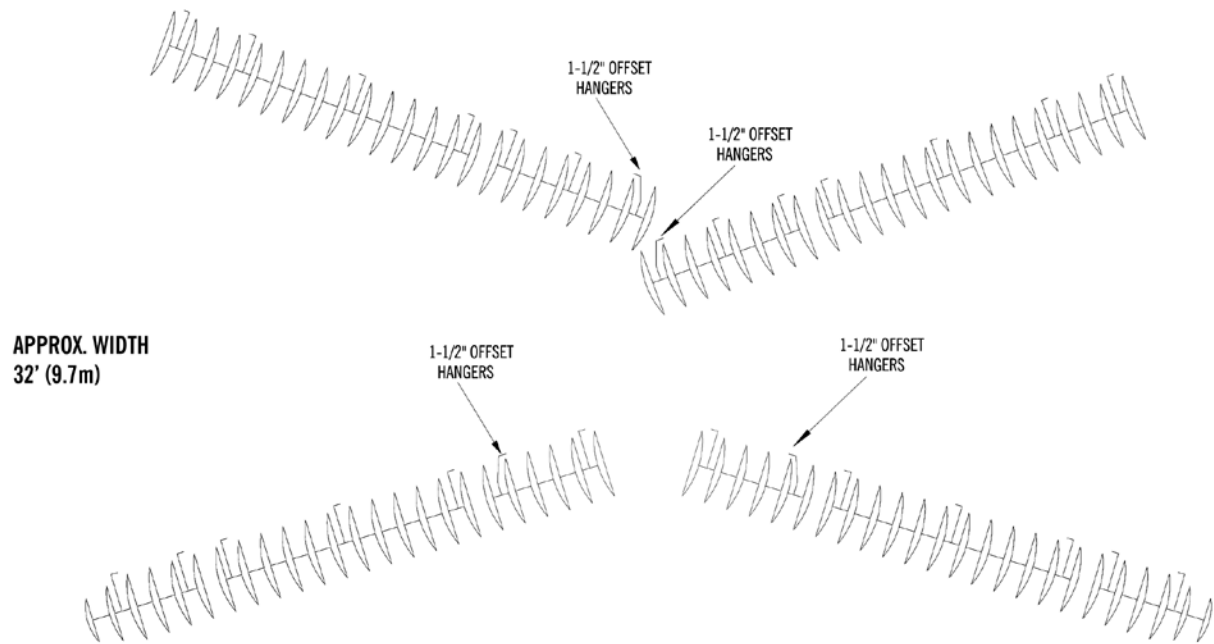

Gang Pattern - 9" Spacing - 46 Blades/20 Bearings - Front

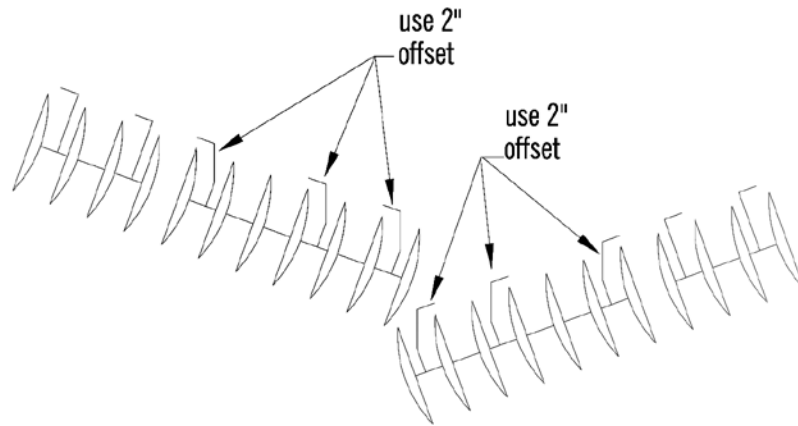

APPROX. WIDTH
18 ft. (5.5m)



Gang Pattern - 9" Spacing - 50 Blades/20 Bearings - Front

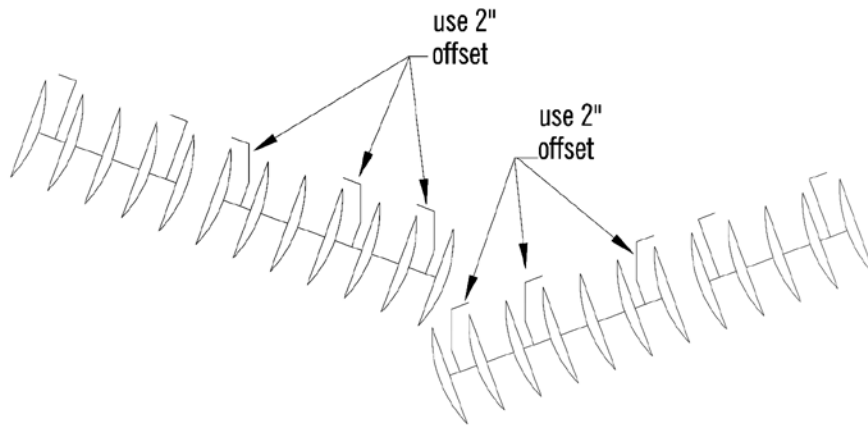

APPROX. WIDTH
19-1/2 ft. (5.9m)



Gang Pattern - 9" Spacing - 54 Blades/20 Bearings - Front

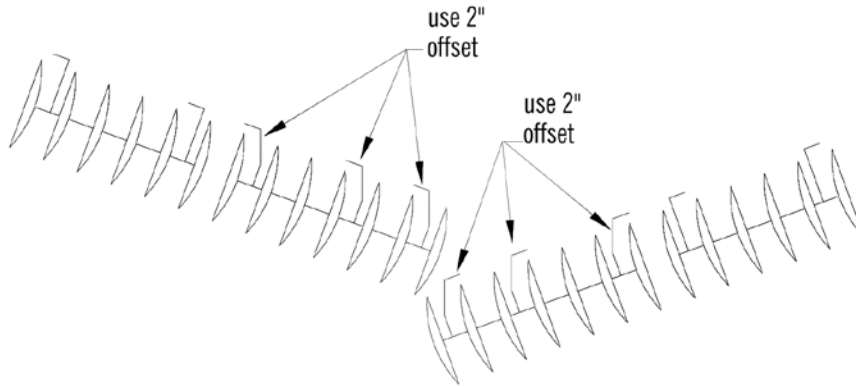

APPROX. WIDTH
21 ft. (6.4m)



Gang Pattern - 9" Spacing - 62 Blades/22 Bearings - Front

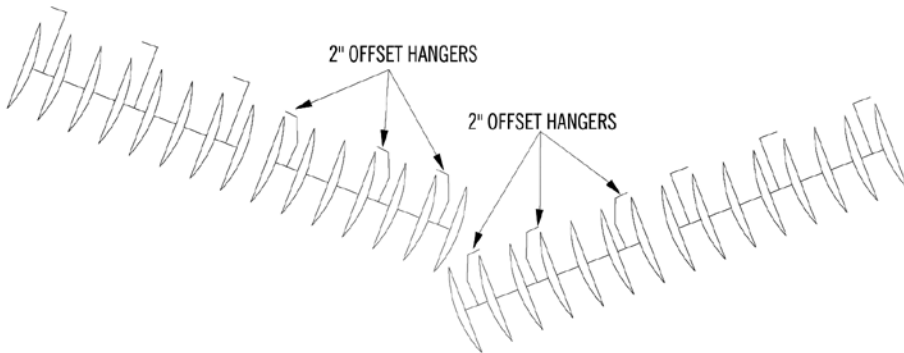

APPROX. WIDTH
23-1/2 ft. (7.16m)

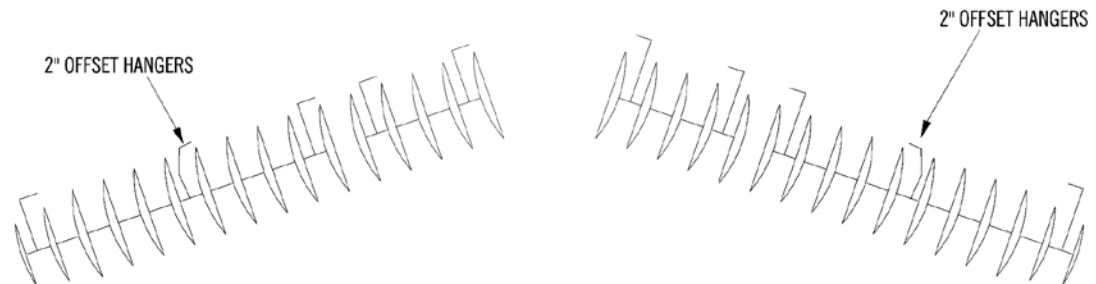

Gang Pattern - 9" Spacing - 66 Blades/22 Bearings - Front

APPROX. WIDTH
25 ft. (7.62m)

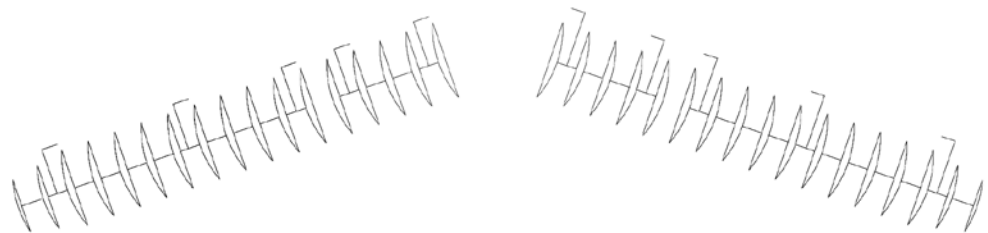
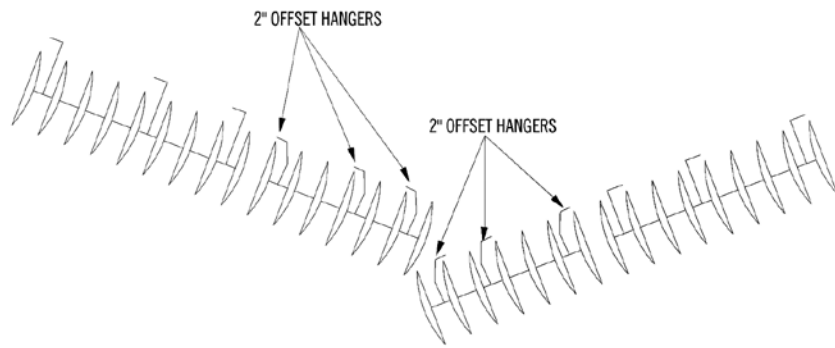

Gang Pattern - 9" Spacing - 70 Blades/22 Bearings - Front

APPROX. WIDTH
26-1/2 ft. (8.08m)

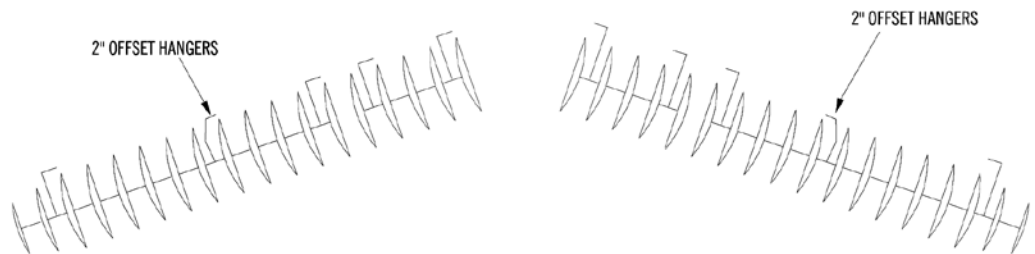
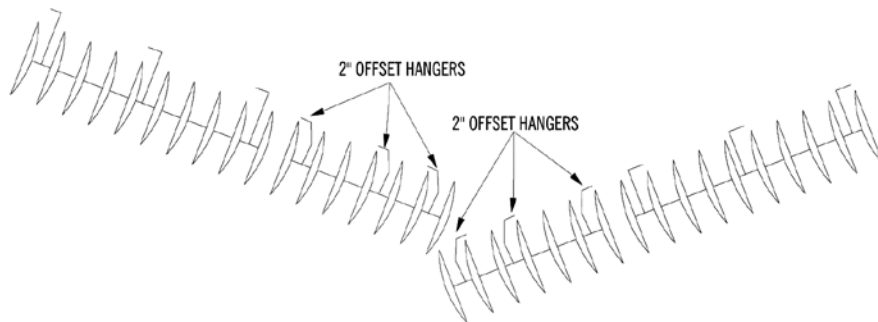

Gang Pattern - 9" Spacing - 74 Blades/20 Bearings - Front

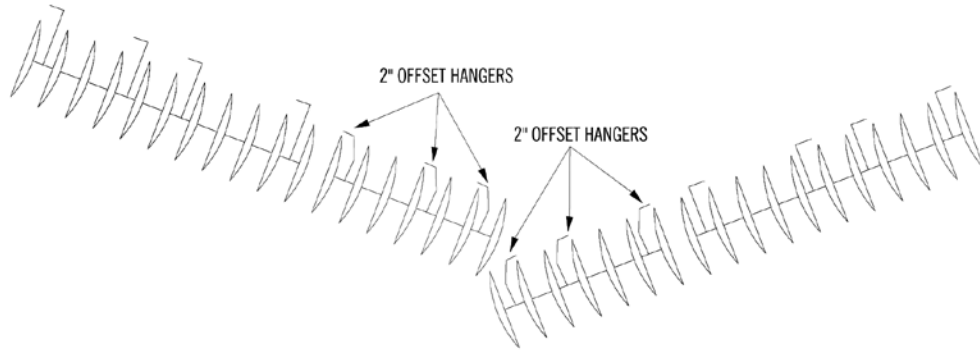

APPROX. WIDTH
28 ft. (8.53m)



Gang Pattern - 9" Spacing - 78 Blades/24 Bearings - Front

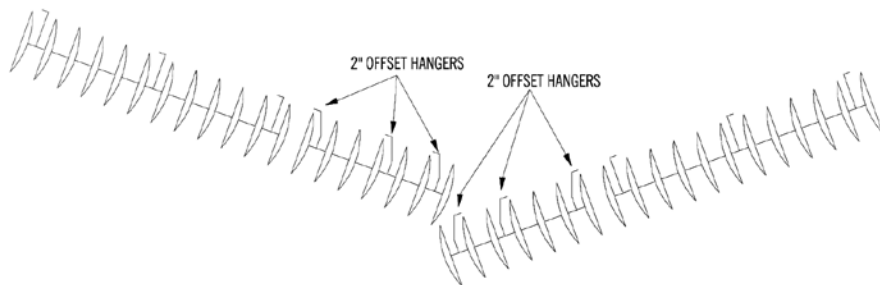

APPROX. WIDTH
29-1/2 ft. (8.99m)



Gang Pattern - 9" Spacing - 86 Blades/26 Bearings - Front

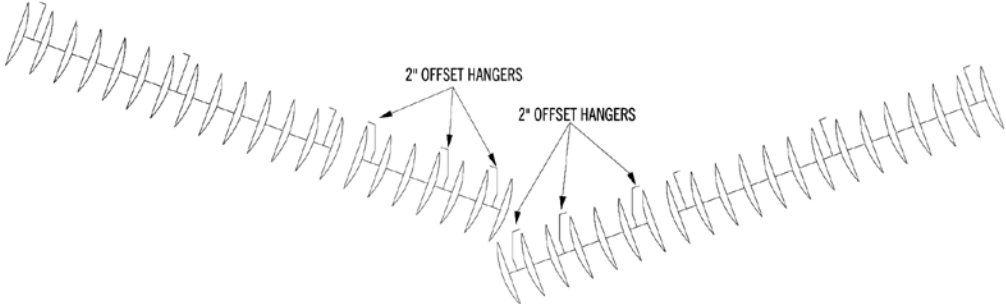

APPROX. WIDTH
32-1/2 ft. (9.91m)



Operation Instructions

1. Review disc safety items applicable to road transport and field operation of disc.
2. **NOTE:** When lowering wings to field position, be sure wing lift cylinders are fully extended. After wing tires have hit the ground continue to hold hydraulic lever. There will be a short pause before cylinders fully extend. If cylinder is not fully extended, the wing will hang on cylinders and will not flex down.



CAUTION

Never stand between the tractor and disc when hitching disc to the tractor unless all tractor controls are in neutral and the park brake is set. The tractor could roll backwards which could result in serious injury or death to you or person(s) nearby.

3. For best performance, the tractor drawbar should be pinned at centre of tractor.
4. Ensure disc is level and cutting depth is properly adjusted.
5. Do not make sharp turns with the disc in ground. Sharp turns put excess pressure on the gangs.

It is advisable to always lift machinery out of ground for making sharp turns. Excessive side thrust is applied to bearings and machine if disc is turned while it is in the ground.

6. See FIG. 1. When transporting disc, always place hydraulic lockup valves in closed position. Lock up valves are located at the front end of centre frame.

FIG. 1

HYDRAULIC LOCKUP VALVES

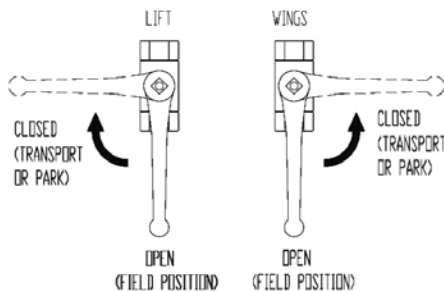
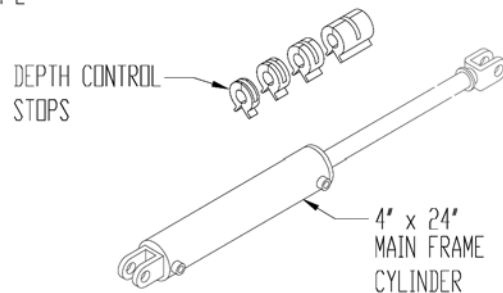

FIG. 2



CAUTION

When transporting disc always place both hydraulic lock up valves in closed position. If the hydraulic lever was accidentally operated the disc could drop or wings could fall causing serious injury or death to operator or person(s) nearby.

7. See FIG. 2. When transporting disc always place the complete depth control package (17" long) on shaft of 4" x 24" centre frame lift cylinder.

**CAUTION**

When transporting disc always install the complete package of depth control stops (17" long) on shaft of centre frame cylinder. If any component or hydraulic system failed disc could drop causing serious injury or death to operator or person(s) nearby.

8. **NOTE:** When transporting disc, do not exceed speed of 10 mph (16 km/h).
9. **NOTE:** Do not disc with front gangs cutting deeper than rear gangs. Disc must be level. If front gangs are lower, excessive strain will be placed on blades, gang bearings and frame hitch, which could lead to premature parts failure, especially outside blades of front gangs.
10. **NOTE:** When disc is parked with blades resting on frozen ground. Do not attempt to lift disc out of frozen ground by lowering transport wheels. Lifting disc out of frozen ground with transport wheels may cause serious damage to disc components. Damage will most likely occur to main lift cylinders and rockshaft cylinder arms.

Do not park disc with blades on ground that may freeze. Leave disc parked on transport wheels.

11. **NOTE:** To avoid serious damage to hitch jack, be sure jack is locked in horizontal position and crank of jack is not hanging below hitch when disc is in motion.
12. **NOTE:** Do not operate disc in field with wing folded in transport position. Severe damage will occur when discing with wings folded.

**CAUTION**

Do not stand under wing while wing is being raised or lowered. If any components should fail, or if hydraulic lever should accidentally be operated, wing could fall.

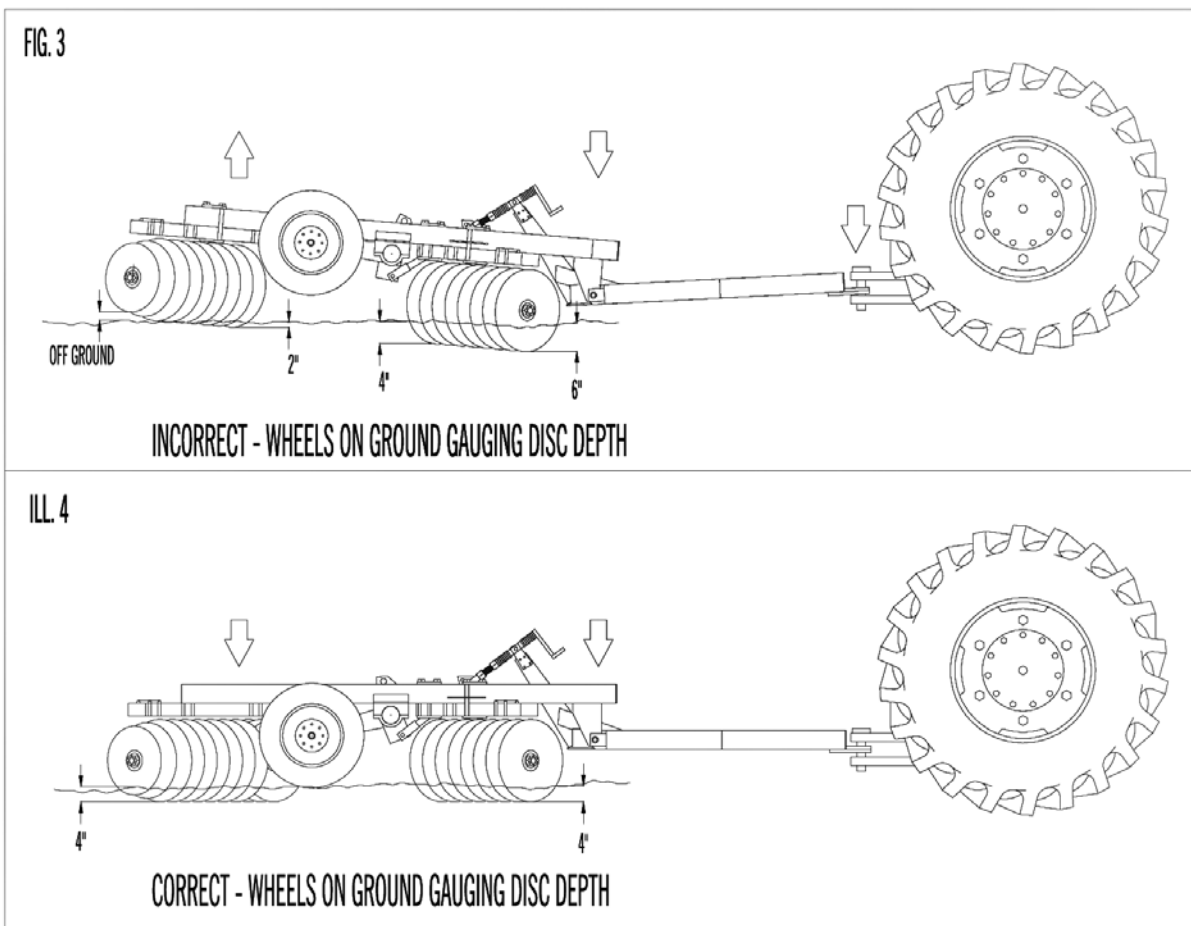

13. Front of disc may drop because rockshaft and hitch levelling arm is linked. As the wheels are raised, the hitch levelling arm is pulled back allowing hitch to float. If hitch is allowed to float it will not support front of disc allowing front gang to drop.

With front of disc lower than the rear, the front outside blades will cut much deeper than the front inside blades. This means that more of the disc's weight is placed on the front outside blades, forcing them deeper into the ground.

Uneven and deep front gang penetration in tough conditions will place excessive strain on blades, gang bearings, frame and hitch, and will lead to a premature failure of parts especially outside blades and bearings of front gangs.

The condition shown in Fig. 3 may also cause frame to buckle upward at frame hinge point, raising centre blades off ground. If frame is level, as shown in Fig. 4 thrust at outside end of front gangs is greatly reduced. Side thrust is distributed evenly on all front blades, reducing the possibility of centre rising.

NOTE: Operating disc with transport wheels off ground will cause uneven discing job and place undue strain on machine which could lead to parts failure. Always operate disc with transport wheels on ground even if soil conditions will not allow disc to penetrate to maximum depth.

- See FIG 5. Attach a safety chain to the tractor drawbar and to the disc's hitch before transporting the disc. Use a chain with strength rating greater than the gross weight of disc. (Safety chain available as an option).

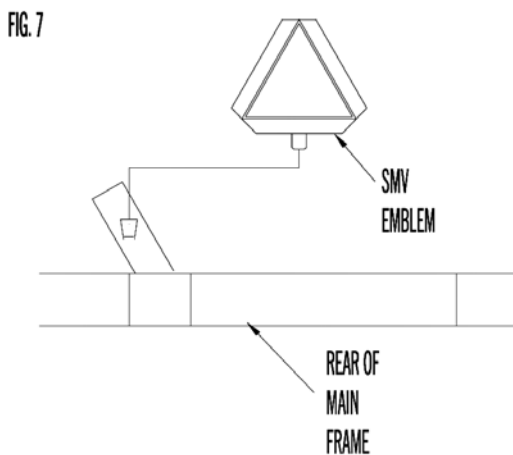
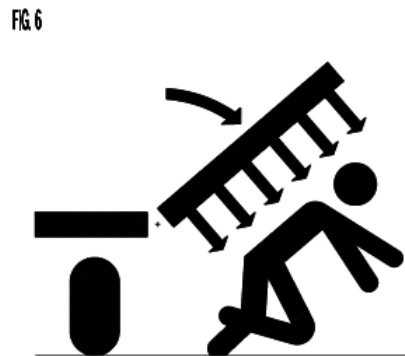
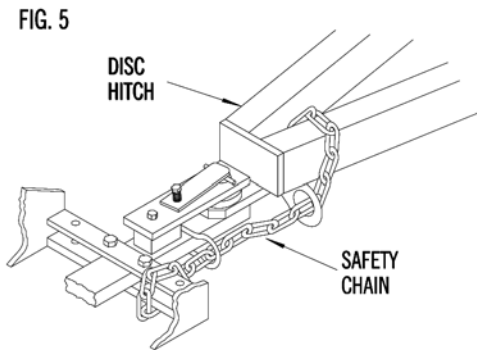

CAUTION

When transporting a disc, be sure to attach a safety chain to tractor drawbar and disc hitch. The safety chain will help control disc should it accidentally separate from the drawbar. Use a chain with a strength rating greater than the gross weight of the towed machine.

Serious damage, injury or death could result from the disc separating from the tractor drawbar.



CAUTION

Do not stand under the wing while it is being raised or lowered. If any component of the hydraulic system failed or if the hydraulic lever was accidentally operated, wing could fall.

15. See FIG. 7. Before transporting disc, install a SMV emblem (not supplied) in the SMV bracket bolted to rear LH gang assembly of center frame.



CAUTION

Use the SMV emblem (not supplied) and warning lights for the protection of tractor and other vehicle operations when transporting the disc over public roads. Check local laws regarding transporting regulations.



CAUTION

When trailing the disc over public roads, use the SMV emblem and warning lights for protection of tractor and other motor vehicle operations. Check local laws for width and weight maximums and height maximums.



CAUTION

Do not exceed 10 mph (16 km/h) when transporting disc on smooth roads, reduce speed when transporting on rough roads. Excessive speed could cause loss of tractor control and damage to disc and tractor. Do not transport disc with any other vehicle except tractor.



DANGER

When transporting disc with wings raised, be sure there is sufficient clearance under all power lines and other overhead obstructions. Serious injury or death can result from contact with electrical lines. Use care to avoid contact with electrical lines when moving or operating disc.



WARNING

When transporting disc, always place hydraulic lock up valve in closed position. If the hydraulic lever was accidentally operated, the disc could drop or wing could fall causing serious injury or death to operator or person(s) nearby.

16. Rephasing rockshaft cylinders - periodically the hydraulic lift cylinders on wing frames will not be synchronized with centre frame cylinder. This will cause uneven cutting depth. If this happens it will be necessary to rephase the lift cylinders. Rephasing is done by lifting disc completely out of the ground and holding the hydraulic control lever until all (3) rockshaft cylinders are fully extended.



WARNING

Never allow anyone to ride on drawbar of the tractor or on the disc. The person riding may fall and be seriously injured.

**WARNING**

Lower the disc to the ground when servicing or making adjustments. If the disc must be serviced or adjusted in the raised position, place blocks under frame. Do not rely on hydraulic lock up valves as a safety device. If the hydraulic system failed, or if the hydraulic lever was to accidentally operated, the disc could drop.

**CAUTION**

When operating on hillsides, use extra care. Tractor may tip sideways if it strikes a hole, ditch or other irregularity.

17. **NOTE:** When parking disc always release pressure in hydraulic cylinders. Serious damage could occur to hydraulic cylinder if thermal expansion of hydraulic oil takes place due to warmer weather or if disc is stored in heated building.
18. **NOTE:** When parking disc always place both hydraulic lockup valves in closed position. See FIG. 1.
19. **NOTE:** In discing conditions where extreme wing flexibility is required, remove cylinder pin from shaft end of each wing lift cylinder and retract cylinders.

When reattaching shaft end of wing lift cylinders to wing frame, be sure cylinder shaft does not strike cylinder lug on wing frame. Serious damage may occur to cylinder if cylinder shaft strikes cylinder lug. Before extending cylinder shafts block up cylinder so that cylinder shaft passes over cylinder lugs.

Adjustments

1. Lateral adjustment of the front and rear gangs

A - Front gangs - See FIG. 9. Loosen U-Bolts which fasten bearing hangers to front gang beams. Adjust front gangs so that leading edge of inside blades are, arrow 1, are approximately 2-1/2" (63.5mm) past centre of disc. The centre of disc is shown in FIG. 9. If the above adjustment is made correctly, the front gang will not leave any unbroken ground at centre of disc.

B - Rear gangs - See FIG. 10. Loosen U-Bolts which fasten bearing hangers to rear gang bearings.

The opening between the rear gangs dimensions "D", must be set at a distance that will allow furrow left by the front gangs to be filled evenly. The distance the rear gangs are set apart is determined by the discing speed, discing depth, gang angle and soil conditions. If the rear gangs are set too close together, the rear gangs will leave a ridge at centre. If rear gangs are set too far apart, the furrow at centre left by the front gangs will not be filled. Take note of the amount of soil the rear inside blades are picking up. It may be necessary to increase distance between rear gangs in order to collect enough soil to fill furrow.

To start with this distance should be set at 2" (50.8mm) less than diameter of blades. For example, if your machine is equipped with 24" (609mm) blades, then the opening (Dimension "D") should be 22" (559mm).

An increase in discing speed may require rear gangs to be set further apart. A decrease in discing speed may require rear gangs to be set closer together.

NOTE: Be sure the blade to blade between individual gangs are adjusted to match your disc's blade spacing.

When gang adjustments are complete, tighten all bearing hanger u-bolts.

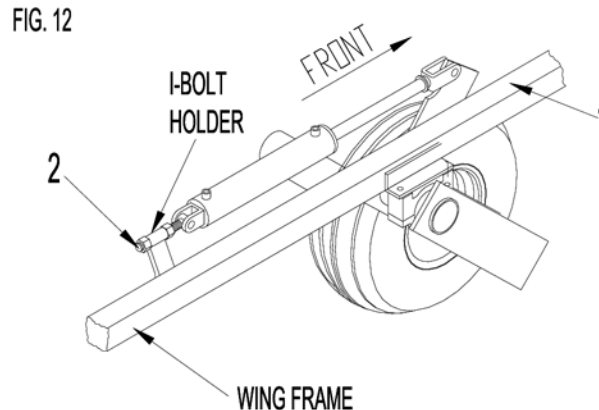
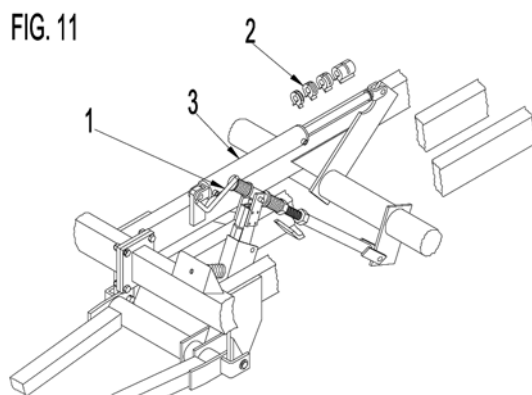
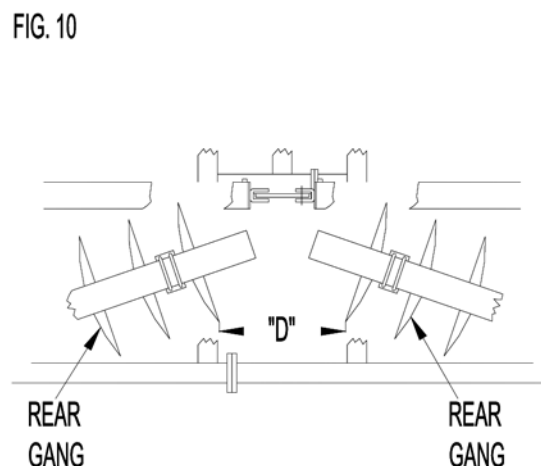
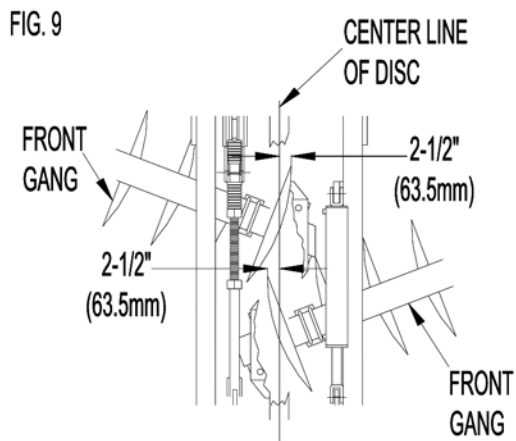

2. **NOTE:** When raising wings into transport for the first time after adjusting gangs, raise wings slowly making sure wing gangs clear centre frame gangs and gang beams.
3. Levelling disc - See FIG. 11. When discing, the front and rear gangs should be cutting at the same depth. The levelling crank, arrow 1, is used to level disc. To lower front gangs, turn crank, arrow 1, clockwise (in). To raise front gangs, turn crank, arrow 1, counter-clockwise (out).

Very Important: Always keep disc level from front to rear. Discing with front gangs lower than rear gangs will cause ridging at outside and may cause damage to disc components.

4. Setting discing depth - See FIG. 11. To set discing depth, install depth control segments, arrow 2, on shaft of center frame cylinder, arrow 3. Install segments as required to obtain desired discing depth.

5. Levelling wing adjustment - See FIG. 12. For even blade penetration, outside of wing frames must be level with centre frame or even 1/2" higher than centre frame. Before this adjustment is made, be sure centre frame is level from front to rear. To level wing frame with centre frame, adjust wing rockshaft cylinder I-bolt, arrow 1. If outside of wing frame needs to be raised, loosen outer nut, arrow 2, and tighten inner nut. This will lower the wheels raising outside of wing. If outside of wing frame needs to be lowered, loosen inner nut and tighten outer nut. This will raise the wheels lowering outside of wing. After adjustments are complete tighten nuts against I-bolt holder.

NOTE: Be sure axis of clevis pin is horizontal with cylinder ports facing up. If clevis bolt is not positioned properly, cylinder will not be free to pivot when activated, causing serious damage.



CAUTION

Always place tractor controls in neutral and lock brakes when hitching disc to tractor, tractor could roll backwards when hitching disc.



CAUTION

When operating on hillsides, use extra care. Tractor may tip sideways if it strikes a hole, ditch or other irregularity.

6. Remove ridge at centre of disc - Make one or more of the following adjustments:
 - A** - Level disc from front to rear using levelling crank, see Section 3 of adjustments.
 - B** - Reduce discing speeds.
 - C** - Increase distance between rear gangs.
7. Remove furrow at centre of disc - Make one or more of the following adjustments:
 - A** - Level disc from front to rear using levelling crank .
 - B** - Increase discing speed.
 - C** - Decrease distance between rear gangs.
8. Remove unbroken ground left by front gangs - Make the following adjustments
 - A** - Adjust leading edge of inside blade of each front gang so it is 2-1/2" (63.5mm) past centre of disc.
9. Reduce gang plugging - Make the following adjustment:
 - A** - Adjust scrapers so they contact blades.

Maintenance

1. Lubrication - See FIG. 13 - Grease all lubricating points on disc marked with arrow G. The oil lubrication points are marked with arrow O.

G1 - Lubricated gang bearings every 20 hours with a minimum amount of grease. Excess lubrication may damage seals. Use a high quality SAE multi-purpose grease.



CAUTION

For 211 or 410 series bearings - If gang bearings are over lubricated, there is a possibility that the seals can be pushed out. This is more likely to happen when bearings are new.

G2 - Lubricate wing pivot points with grease every 50 hours of operation.

G3 - Lubricate levelling crank with grease every 100 hours of operation.

G4 - Lubricate wheels with grease every 50 hours of operation.

G5 - Lubricate top and bottom half of each rockshaft bearing every 20 hours of operation. If rockshaft bearings are not lubricated, there will be excessive wearing of rockshaft and rockshaft bearings.

NOTE: When you receive your new disc, grease all lubricating points before starting to disc. Do not over lubricate gang bearings.

O1 - Lubricate levelling crank ball joints (with oil) at the end and beginning of each season.

2. All bolts and nuts should be checked periodically to make sure they are tight. Special attention should be given to gang bolts, bearing bolts and bearing hanger u-bolts, and wheel bolts. If gang bolts come loose, they must be tightened to 3200 ft lbs (4436 N.m).

Tighten bolts as follows:

- Gang bolts 1-15/16" (49mm) diameter - 3200 ft lbs (4339 N.m) torque.
- See FIG. 14. To tighten gang bolt to 3200 ft lbs (4339 N.m) install a 10 ft (3.05m) bar in socket wrench and apply 320 lbs (145 kgs) of force to end of bar.

NOTE: After repairing, the gang bolt should be retightened after 2 hours of operation.

- Levelling crank bolt 1-1/4" (31.7mm) diameter - 840 ft lbs (1139 N.m) torque (minimum/maximum).
- Wheel bolts 9/16" (14.2mm) diameter - 130 ft lbs (176.3 N.m) torque.
- Bearing hanger u-bolts (for Stone Flex Hangers) - 3/4" (19mm) diameter - 260 ft lbs (30 m/kgs) torque.
- Bearing hanger u-bolts (for Solid Hangers) - 5/8" (15.7mm) diameter - 430 ft lbs (59.5 m/kgs)

NOTE: Gangs should be re-tightened after 2 hours of operation.

Very Important: Severe damage will occur if gang bolts are loose.

3. When storing disc for a long period of time, grease all lubricating points.
4. Ensure tires are properly inflated. See specifications section for tire pressures.

	<p><u>CAUTION</u> Do not service disc while it is in motion. You may fall in front of disc and be seriously injured.</p>
---	---



	<p><u>CAUTION</u> Lower the disc to the ground when servicing or making adjustments. If the disc must be serviced or adjusted in the raised position, place blocks under frame. Do not rely on hydraulic lock up valves as a safety device. If the hydraulic system failed, the disc could drop.</p>
---	---

FIG. 14

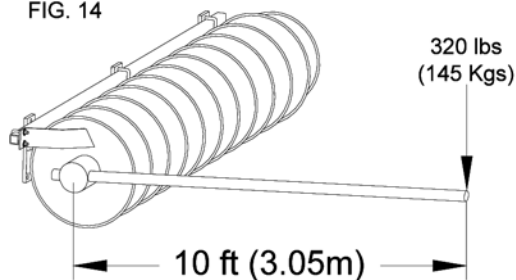

5. Wing lift cylinder removal - See FIG. 14. If possible lower wings to field position if the wing lift cylinder hydraulic system must be serviced or repaired. If a wing lift cylinder hydraulic system must be serviced or repaired with wings in folded position, install a safety chain between both wings and main frame to prevent wings from falling down. Always install a chain on both wings even if only one cylinder is being worked on.

	<p><u>CAUTION</u> Always relieve the pressure in hydraulic system and close both hydraulic lockup valves when the disc is not being used.</p>
---	--

	<p><u>CAUTION</u> If wing lift cylinder(s) or wing lift hydraulic hoses are removed when wings are folded into transport position, always install a safety chain between wing frames and main frame to prevent wings from falling. If wings fell, serious injury or death could occur to person(s) nearby and machine would be damaged severely.</p>
---	---

6. Keep all safety decals clean and in good condition to provide a constant reminder of safe operating procedures.
7. Replace any destroyed, missing or illegible decals and reflectors.
8. **NOTE:** When storing disc do not leave cylinders under hydraulic pressure, especially if cylinders are activated during cool temperatures. The expansion of oil which takes place when the machine is in a warmer environment or hot weather return may cause serious damage to cylinder, lines or hoses.
9. **NOTE:** Wings may unfold due to thermal expansion of hydraulic oil causing damage to cultivator, property or severe injury or death to person(s) nearby. Release pressure in all cylinders and close hydraulic lockup valves before unhitching from tractor or when parking with tractor.

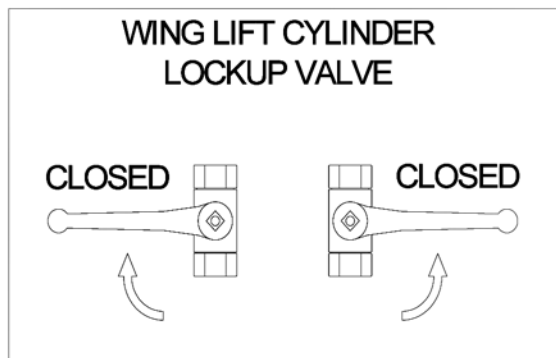

Troubleshooting

Problem	Possible Cause	Remedy
Outside blades of front gangs are cutting too deep causing disc to ridge at outside.	Wheel raised off ground causing front of disc to drop.	Lower wheels to ground so they gauge discing depth.
	Tire pressure is low on outer wheels causing disc to cut deep at outside.	Inflate tire.
	Disc is lower at front than rear.	Using levelling crank raise front of disc.
Outside blades on wing(s) are cutting too deep.	Outside of wing frame(s) is lower than main frame.	raise outside of wing with wing rockshaft cylinder anchor bolt
	wing rockshaft cylinder(s) is not synchronized with main frame rockshaft cylinder.	Rephrase rockshaft cylinder(s)
Outside blades on wing are not cutting deep enough.	Outside of wing frame is higher than main frame.	Lower outside of wing with wing rockshaft cylinder anchor bolt.
	wing rockshaft cylinder(s) is not synchronized with main frame rockshaft cylinder.	Rephrase rockshaft cylinder(s).
Disc is leaving a ridge at centre of discing.	Rear gangs are cutting deeper than front gangs.	Level disc using levelling crank.
	A high discing speed is causing disc to throw dirt further resulting in a pile at centre.	Reduce discing speed.
	Rear gangs are too close together.	Increase distance between rear gangs.
Disc is leaving a furrow at centre of disc.	Front gangs are cutting deeper than rear gangs.	Level disc using levelling crank.
	A low discing speed is causing disc to not throw dirt far enough to fill furrow left by front centre blades.	Increase discing speed.
	Rear gangs are too far apart.	Decrease distance between rear gangs.
Front gangs are leaving unbroken ground at centre of disc.	Scrapers are too far from blades.	Adjust overlap of front gangs.
Disc gangs are plugging	Scrapers are too far from blades.	Adjust scrapers so they are contracting blades.
When raising disc out of ground, outside of wing comes out of ground while main frame lags behind or does not come out of ground.	Piston seals on main frame rockshaft cylinder is damaged	Replace piston seals of main frame rockshaft cylinder.

Problem	Possible Cause	Remedy
When raising disc out of ground, main frame rockshaft cylinder is fully extended while wing rockshaft cylinder is not fully extended.	Rockshaft cylinders are not synchronized.	Rephrase rockshaft cylinder.
When raising disc out of ground, wing rockshaft cylinder is fully extended while main frame rockshaft cylinder is not fully extended.	Rockshaft cylinders are not synchronized.	Rephrase rockshaft cylinder.

Frame Assembly

Need drawing to go here

Item	Part #	Description	Qty
1	DFA13520	Main Frame c/w Ref. #'s 4, 8, 9, 11 and 12	1
2	DWA13521	L.H. Wide Wing Frame - 93" (2362mm) overall width for 28' (8.53m) models and larger c/w gang beam shims and 3/4" x 2-1/2" (19.1 x 63.5mm) gang beam bolts with nuts and lockwashers	1
	DWA13523	L.H. Narrow Wing Frame - 65" (1651mm) overall width for 27' (8.23m) models and smaller c/w gang beam shims and 3/4" x 2-1/2" (19.1 x 63.5mm) gang beam bolts with nuts and lockwashers	1
3	DWA13522	R.H. Wide Wing Frame - 93" (2362m) overall width for 28' (8.53m) models and larger c/w gang beam shims and with 3/4" x 2-1/2" (19.1 x 63.5mm) gang beam bolts with nuts and lockwashers	1
	DWA13524	R.H. Narrow Wing Frame - 65" (1651mm) overall width for 27' (8.23m) models and smaller c/w gang beam shims and 3/4" x 2-1/2" (19.1 x 63.5mm) gang beam bolts with nuts and lockwashers	1
4	C50546	SMV Bracket	2
5	DC9615	10-7/8" (276.2mm) long Compression Spring	1
6	B100140	1" x 14" (25.4 x 355.6mm) N.C. Hex Bolt	1
7	B125080	1-1/4" x 8" (31.8 x 203.2mm) N.C. Hex Bolt	4
8	BW125	1-1/4" (31.8mm) Lockwasher	4
9	BN100	1" (25.4mm) N.C. Hex Nut	2
10	BN125	1-1/4" (31.8mm) N.C. Hex Nut	4
11	DFA10536	Single Spring Cushion Plate	1
12	DFA9564	1-1/4" (31.7mm) N.C. I-Bolt Cylinder Lug	2
13		Hinge Lug – Bolt on – Front R.H. and Rear L.H & R.H. – used 2006 and later	3
14		Hinge Lug – Bolt on – Front L.H. Only – used 2006 and later	1

Gang Beam Assembly

Need drawing to go here

Item	Part #	Description	Qty
1		8" Spacing	2
	DWA10192	16" (406.4mm) Front Wing Gang Beam - 70 blade	
	DWA10195	24" (609.6mm) Front Wing Gang Beam - 74 & 86 blade	
	DWA10198	36" (914.4mm) Front Wing Gang Beam - 78 & 94 blade	
		46" (1168.4mm) Front Wing Gang Beam - 82 blade	
		9" Spacing	2
	DWA10192	16" (406.4mm) Front Wing Gang Beam - 62 & 74 blade	
	DWA10195	24" (609.6mm) Front Wing Gang Beam - 66 & 78 blade	
	DWA10198	36" (914.4mm) Front Wing Gang Beam - 70 blade	
	DWA10202	42" (1066.8mm) Front Wing Gang Beam - 86 & 74 blade	
2		8" Spacing	2
	DWA10202	42" (1066.8mm) Rear Wing Gang Beam - 70 blade	
	DWA10208	50" (1270mm) Rear Wing Gang Beam - 74 blade	
	DWA10226	58" (1473.2mm) Rear Wing Gang Beam - 78 blade	
	DWA10205	46" (1168.4mm) Rear Wing Gang Beam - 86 blade	
	DWA10229	66" (1676.4mm) Rear Wing Gang Beam - 94 blade	
		9" Spacing	2
	DWA10202	42" (1066.8mm) Rear Wing Gang Beam - 62 & 74 blade	
	DWA10208	50" (1270mm) Rear Wing Gang Beam - 66 blade	
	DWA10226	58" (1473.2mm) Rear Wing Gang Beam - 70 blade	
	DWA10205	46" (1168.4mm) Rear Wing Gang Beam - 78 blade	
	DWA10229	66" (1676.4mm) Rear Wing Gang Beam - 86 blade	
3	DGA10107	12" (304.8mm) Gang Beam Extension	4
4	DF10046	Gang Beam Shim	*
5		3/4" x 2-1/2" (19.1 x 63.5mm) N.C. Hex Bolt Gr. 5 (plated)	32
6		3/4" (19.1mm) N.C. Hex Nut (plated)	32
7		3/4" (19.1mm) Lockwasher	32

Frame and Gang Beam Decals

Need drawing to go here

Item	Part #	Description	Qty
1	DF13500	4490 Decal - 3-1/4" x 11" (82.6 x 279)	4
3	DF9507	Danger Decal - 3-1/2" x 14-7/8" (88.9 x 311mm)	2
4	DF13001	Hydraulic Lockup Decal - 2-5/8" x 7" (66.7 x 178mm)	1
5	DF7152	Maintenance Decal - 2-1/2" x 9" (63.5 x 229mm)	1
6	DF9506	Danger, Caution Decal - 2-1/4" x 11-1/2" (57.2 x 292mm)	1
7	DF9510	Caution Decal - 3-1/2" x 15-1/4" (88.9 x 387mm)	1
8	DF10057	Yellow Reflector - 2" x 9" (50.8 x 228.6mm)	6
9	DF10050	Red Reflector - 2" x 9" (50.8 x 228.6mm)	6
10	A70023	Serial Tag - 2" x 3-1/4" (50.8 x 82.6mm)	1
11	A75764	Read Manual Decal - 2-5/16" x 4-1/2" (58.6 x 114.3mm)	1
12	DF9510	Safety Recommendation Decal - 3-1/2" x 15-1/4" (88.9 x 387.4mm)	1
13	A75759	Important Decal - 2-5/8" x 4-3/4" (66.7mm x 120.7mm)	1
	L010	1 Liter Black Paint	*
	L016	1/2 Pint Black Paint	*

*As required

Hitch and Leveling Crank Assembly

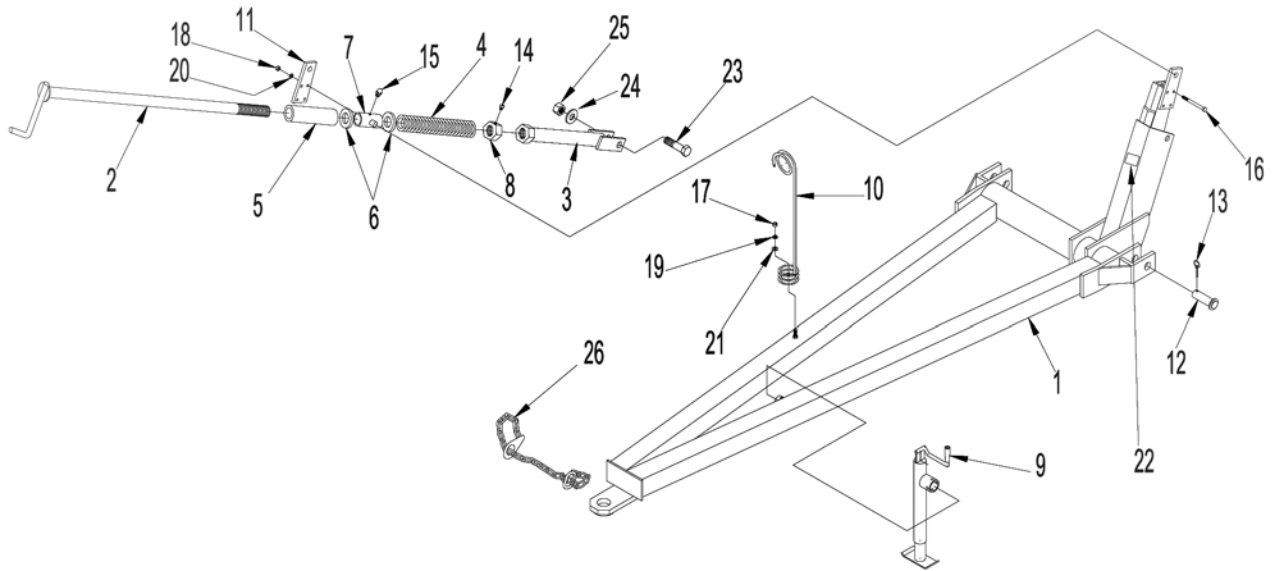

Item	Part #	Description	Qty
1	DHB13097	Hitch c/w item 11, 12, 13 and 18	1
2	DCA9970	Leveling Crank - 50" (1270mm) Long	1
3	DCA5195	Leveling Link - 16-3/4" (60.4mm) Pipe Length	1
4	DC9618	Compression Spring	1
5	DC13098	Spacer Tube - 2-3/8" O.D. x 3/16" I.D. x 11" (60.2 x 4.76 x 279mm) Long	1
6	DC15	Thrust Bearing - Timken #T199	2
7	DCA5184	Bearing Tube - Leveling Crank	1
8	DH5	2" N.C. (50.8mm) Heavy Hex Nut - Drilled for set screw	1
9	DHB5170	Hitch Jack	1
10	DH9961	Hose Support - Spring coil type	1
11	DH5146	Leveling Arm Lug	1
12	DHA9605	Hitch Pin - 1-1/2" Dia. x 5" (38.1 x 127mm)	2
13	DH12517	7/16" x 1-7/16" (10.9 x 36.3mm) Lynch Pin	2
14		1/2" x 1" (12.7 x 25.4mm) N.C. Square Head Set Screw	1
15	10GN1	1/4" (6.35mm) - 28 Straight Grease Fitting	1
16		1/2" x 5" (12.7 x 127mm) N.C. Hex Bolt	4
17		5/8" (15.7mm) N.C. Hex Bolt	1
18		1/2" (12.7mm) N.C. Hex Nut	4
19		5/8" (15.7mm) Lockwasher	1
20		1/2" (12.7mm) Lockwasher	4
21		11/16" I.D. x 1-3/4" O.D. (17.2 x 44.4mm) Flatwasher	1
22	DH7148	Crank Decal - 2-1/4" x 2-3/4" (57.2 x 140mm)	1
23	DR5215	1-1/4" x 4-3/4" N.C. (31.7 x 120.6mm) Hex Bolt w/ Special Thread Length	1
24		1-1/4" (31.7mm) Lockwasher	1
25		1-1/4" (31.7mm) N.C. Hex Nut	1

*As required

Rockshaft and Wheel Assembly

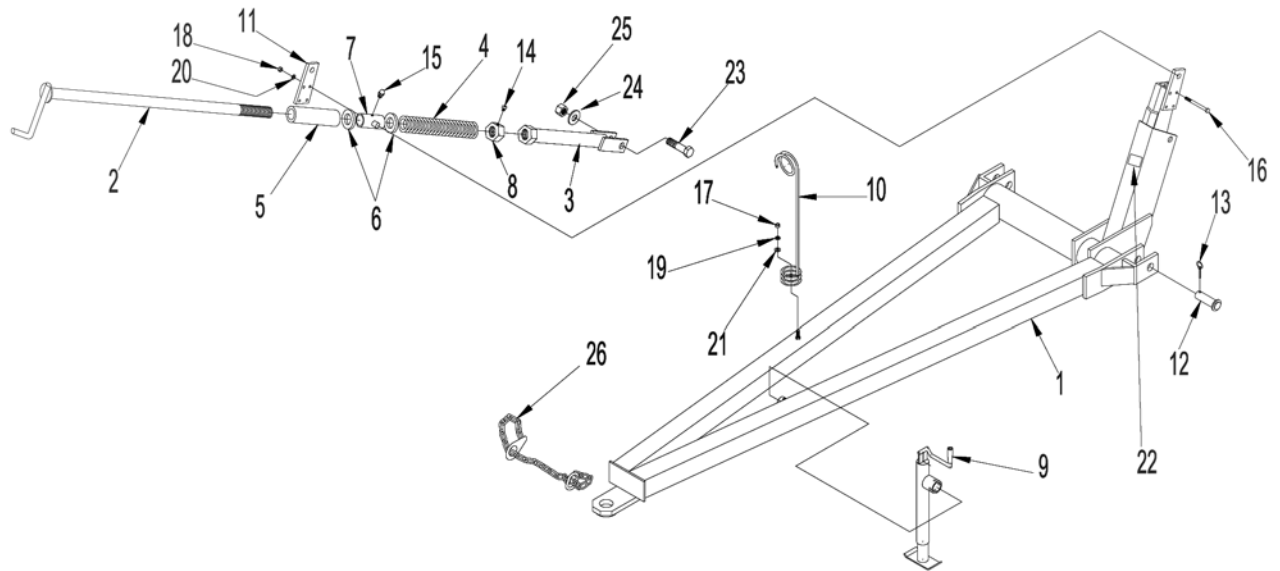

Item	Part #	Description	Qty
1	DRA13525	Main Frame Rockshaft	1
2	DRA13093	L.H. Narrow Wing Rockshaft	1
3	DRA13095	R.H. Narrow Wing Rockshaft	1
4	DR8601T	Rockshaft Bearing - Top Half	7
5	DR8601B	Rockshaft Bearing - Bottom Half	7
6	DR7156	618 Spindle - 14-1/2" (368.3mm)	*
7		2" O.D. x 1-1/16" I.D. x 1/8" (50.8 x 27.0 x 3.2mm) Flatwasher	*
8		3/16" x 1-1/4" (4.8 x 31.2mm) Cotter Pin	*
9	DR110	1" N.F. (25.4mm) Hex Slotted Nut	*
10	DR122	Grease Seal	*
11	DR120	Cone Bearing - #LM25580	*
12	DR118	Cup - #LM25520	*
13	DRA9	618 Hub c/w Cups	*
14	DR92	Cup - #LM48510	*
15	DR91	Cone-Bearing - #LM48548	*
16	DR123	Hub Cap	*
17	C60160	15" x 8" (381 x 203.2mm) - 6 Bolt Rim w/ Stem Protector	*
18		11L x 15 FI Load Range F - Main Frame Only	*
		11L x 15 FI Load Range C - Wing Frame Only	*
19		3/4" x 6-1/2" N.C. (19 x 165mm) Hex Bolt Gr. 5	*
20		1/2" x 3-1/2" N.C. (12.7 x 88.9mm) Hex Bolt Gr. 5	*
21	DR125	9/16" x 1-1/8" (14.3 x 28.6mm) Wheel Bolt	*
22		1/2" (12.7mm) N.C. Nylon Locknut	*
23		3/4" (19.1mm) N.C Hex Nut	*
24		3/4" (19.1mm) Lockwasher	*
25	10GN1	1/4" (6.35mm) - 28 Straight Grease Fitting	*
26	DR13120	1-1/4" I.D. x 1-1/4" (31.7 x 31.7mm) Long Steel Insert	*
27	10GN3	Pressed in Grease Fitting	*
	10GN1	1/4" (6.35mm) - 28 Straight Grease Fitting - Threaded	*
28	DR5227	1-1/4" I.D. (31.7mm) Ball Joint - Weld-on	*
29	DR13190	Seal - Spindle Mount Type	*
30	DR13191	Seal Cup - Spindle Mount Type Seal	*
31	C60154	Steel Valve Stem	*

*As required

Hydraulic Assembly

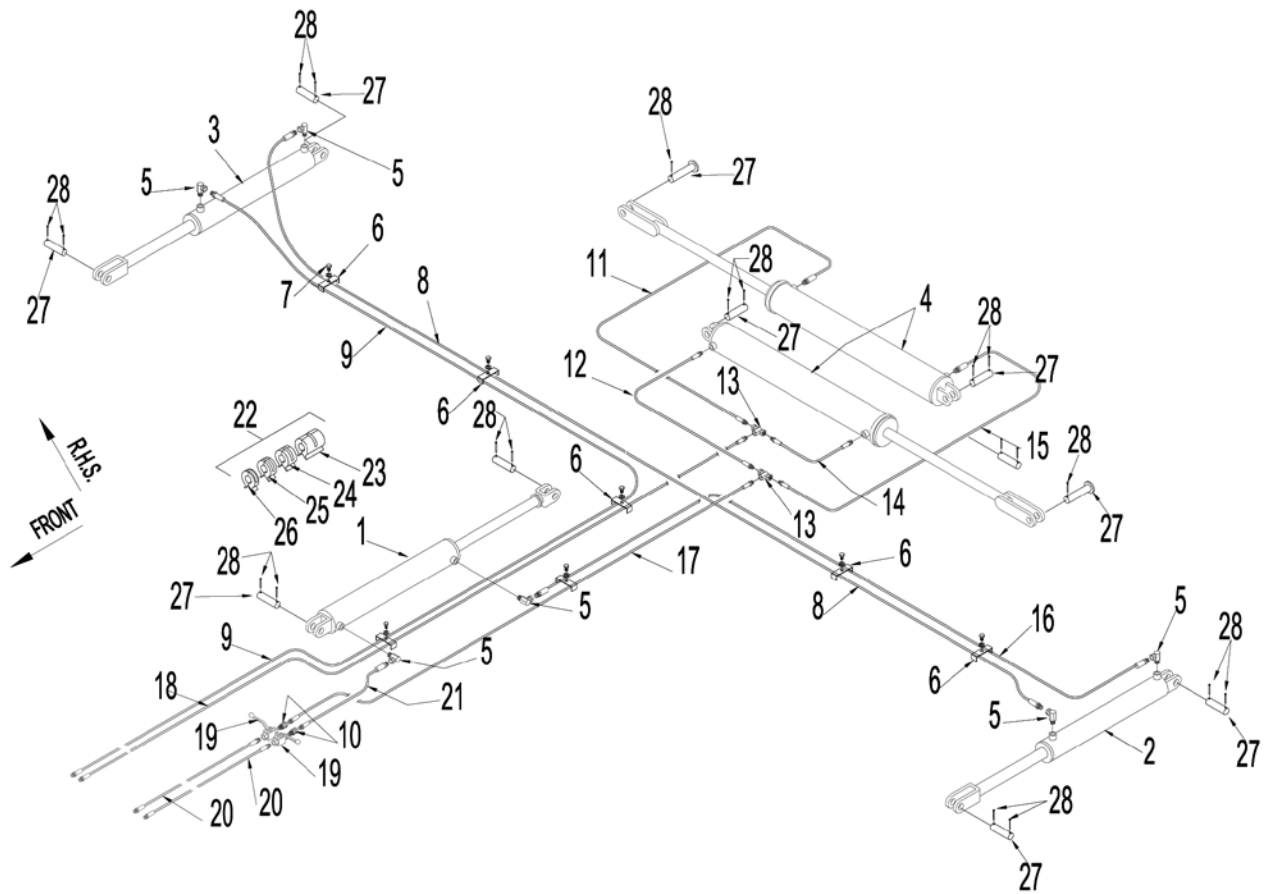

Item	Part #	Description	Qty
1	306	4" x 24" (102 x 610mm) Main Frame Rockshaft Cylinder	1
2	305	3-1/2" x 24" (89 x 610mm) L.H. Wing Rockshaft Cylinder	1
3	304	3" x 24" (76 x 610mm) R.H. Wing Rockshaft Cylinder	1
4	242	5" x 36" (127 x 914mm) Main Frame Rockshaft Cylinder	2
5	DL9775	1/2" (12.7mm) x 90 degree Swivel Street Elbow	6
6	DL13186	Hose Retainer - 2 Hose	7
7		1/2" x 3/4" (12.7 x 19mm) Bolt w/ Lockwashers Gr. 5	7
8	D4354	3/8" x 225" (9.4 x 5715mm) Hydraulic Hose - Narrow Wing	1
	D4355	3/8" x 292" (9.4 x 7417mm) Hydraulic Hose - Wide Wing	1
9	D4356	3/8" x 393" (9.4 x 9982mm) Hydraulic Hose - Wide Wing	1
	D4357	3/8" x 412" (9.4 x 10465mm) Hydraulic Hose - Wide Wing	1
10	L1619	3/8" (9.4mm) Male - Female Swivel Adapter	2
11	L2910	3/8" x 42" (9.4 x 1067mm) Hydraulic Hose w/ 3/8" (9.4mm) ends	1
12	L2937	1/4" x 30" (6.35 x 762mm) Hydraulic Hose w/ 3/8" (9.4mm) ends	1
13	DL5282	Female Swivel Tee	2
14	H30	3/8" x 30" (9.4 x 762mm) Hydraulic Hose w/ 3/8" (9.4mm) ends	1
15	D4358	1/4" x 42" (6.35 x 1067mm) Hydraulic Hose w/ 3/8" (9.4mm) ends	1
16	D4359	3/8" x 185" (9.4 x 4699mm) Hydraulic Hose - Narrow Wing	1
	D4360	3/8" x 212" (9.4 x 5385mm) Hydraulic Hose - Wide Wing	1
17	D4361	3/8" x 104" (9.4 x 2642mm) Hydraulic Hose w/ 3/8" (9.4mm) ends	1
18	D4362	3/8" x 278" (9.4 x 7061mm) Hydraulic Hose w/ 1/2" & 3/8" (12.7& 9.4mm) ends	1
19	DL13099	Hydraulic Shut Off Valve	2
20	D4362	3/8" x 168" (9.4 x 4267mm) Hydraulic Hose w/ 1/2" & 3/8" (12.7 & 9.4mm) ends	1
21	D4364	3/8" x 22" (9.4 x 559mm) Hydraulic Hose w/ 1/2" & 3/8" (12.7 & 9.4mm) ends	1
22	C50724	Wadler Stroke Control Segment Package - 8-3/4" (222mm)	2
23	C50717	4-1/4" (108mm) Depth Stop	2
24	C50714	2" (50.8mm) Depth Stop	2
25	C50712	1-1/2" (38.1mm) Depth Stop	2
26	C50711	1" (25.4mm) Depth Stop	2
27	DR5262	1-1/4" Dia. x 4-3/16" (31.7 x 106.4mm) Clevis Pin	10
28	BP3117	5/16" x 2" (7.87 x 50.8mm) Cotter Pin	18

*As required

Scraper Assembly

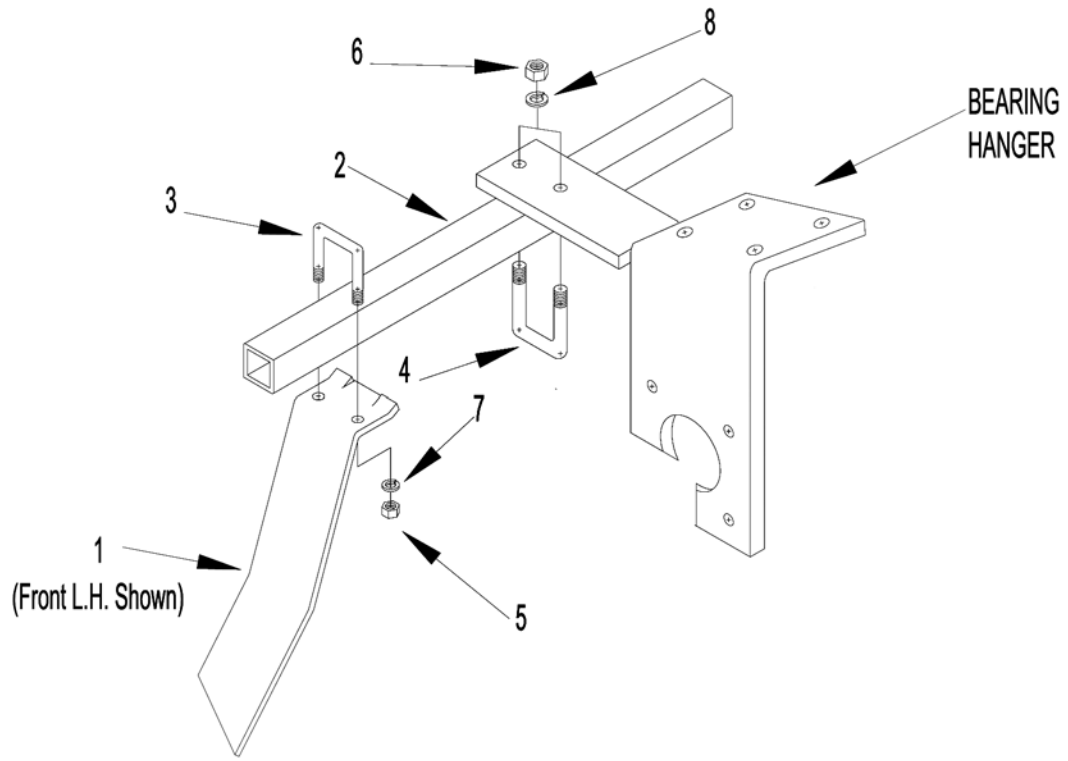

Item	Part #	Description	Qty
1	DG6083	Front R.H. - Rear L.H. Scraper	*
	DG6084	Front L.H. - Rear R.H. Scraper	*

2		Scraper Bar - 8" (203.2mm) Spacing	
	DS49	6 Blade Scraper Bar - 49" (1245mm)	*
	DS57	7 Blade Scraper Bar - 57-1/2" (1461mm)	*
	DS65	8 Blade Scraper Bar - 65-1/2" (1664mm)	*
	DS73	9 Blade Scraper Bar - 73-1/2" (1867mm)	*
	DS82	10 Blade Scraper Bar - 82" (2083mm)	*
	DS90	11 Blade Scraper Bar - 90" (2286mm)	*
	DS99	12 Blade Scraper Bar - 99" (2515mm)	*
	DS107	13 Blade Scraper Bar - 107" (2718mm)	*
	DS115	14 Blade Scraper Bar - 115-1/2" (2934mm)	*
	DS123	15 Blade Scraper Bar - 123-1/2" (3137mm)	*

		Scraper Bar - 9" (228.6mm) Spacing	
		5 Blade Scraper Bar - 45-1/2" (1156mm)	*
		6 Blade Scraper Bar - 55" (1397mm)	*
		7 Blade Scraper Bar - 64" (1626mm)	*
		8 Blade Scraper Bar - 73-1/2" (1867mm)	*
		9 Blade Scraper Bar - 82" (2083mm)	*
		10 Blade Scraper Bar - 92" (2337mm)	*
		11 Blade Scraper Bar - 101-1/2" (2578mm)	*
		12 Blade Scraper Bar - 110" (2794mm)	*
		13 Blade Scraper Bar - 120" (3048mm)	*
		14 Blade Scraper Bar - 129-1/2" (3289mm)	*

3		1/2" x 2" (12.7 x 50.8mm) U-Bolt - Plated	*
4		5/8" x 2" (15.9 x 50.8mm) U-Bolt - Plated	*
5		1/2" (12.7mm) N.C. Hex Nut - Plated	*
6		5/8" (15.9mm) N.C. Hex Nut - Plated	*
7		1/2" (12.7mm) Lockwasher - Plated	*
8		5/8" (15.9mm) Lockwasher - Plated	*

*As required

Disc Gang Assembly

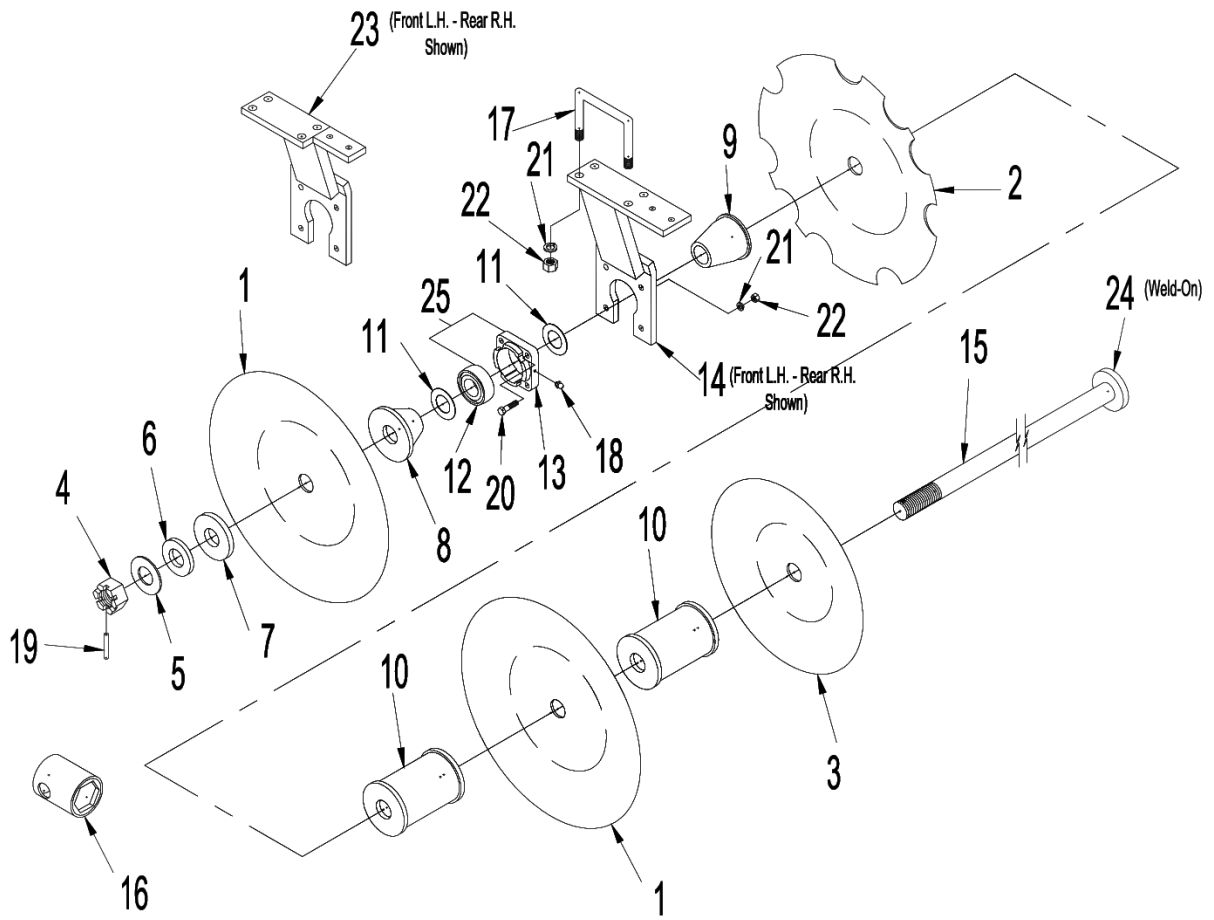

Item	Part #	Description	Qty
1	DG60	22" x 7mm (559mm x .275) Plain Blade	*
	DG76	24" x 7mm (609.6mm x .275) Plain Blade	*
	DG137	24" x 8mm (609.6mm x 5/16) Plain Blade	*
2	DG61	22" x 7mm (558.8mm x .275) Notched Blade	*
	DG138	24" x 8mm (509.6mm x 5/16) Notched Blade	*
3	DG84	16" x 4mm (406.4mm x .157) Plain Outrigger Blade	*
	DG133	18" x 5mm (457.2mm x .197) Plain Outrigger Blade	*
	DG149	20" x 6mm (508mm x .236) Plain Outrigger Blade	*
4	DG82	2" (50.8mm) Heavy Hex Slotted Nut	*
5	DG89	1/4" (6.35mm) Shim Washer	*
6	DG88	1/2" (12.7mm) Shim Washer	*
7	DG78	5" O.D. x 2" I.D. x 5/8" (127 x 50.8 x 15.9mm) Head Washer	*
8	DG108	8" (203.2mm) Spacing Short Half Spool - 2-3/8" (69.9mm) Long	*
	DGA97	9" (228.6mm) Spacing Short Half Spool - 3-1/4" Long w/ 5" (127mm) Washer	*
9	DGA102	9" (228.6mm) Spacing Long Half Spool - 4-7/16" (112.7mm) Long - 211	*
	DGA103	9" (228.6mm) Spacing Long Half Spool - 4-3/16" (106.3mm) Long	*
10	DGA113	8" (203.2mm) Spacing Full Spool - 8" (203.2mm) Long	*
	DGA98	9" (228.6mm) Spacing Full Spool - 9" (228.6mm) Long w/ 5" (127mm) Washer	*
11	DG236	3-5/8" O.D. x 2" I.D. x 1/16" (92 x 50.8 x 1.59mm) Bearing Shield - 211	*
	DG237	4-1/2" O.D. x 2" I.D. x 1/16" (114 x 50.8 x 1.59mm) Bearing Shield	*
12	DG95	211 Series Greaseable Bearing	*
	DG5364	EZ410N Series Greaseable Bearing	*
13	DG94	211 Bearing Housing Only	*
	DG96	EZ410N Bearing Housing Only	*
14	DGA6089	Front L.H. - Rear R.H. Straight Bearing Hanger - 211 Bearing	*
	DGA6090	Front R.H. - Rear L.H. Straight Bearing Hanger - 211 Bearing	*
	DGA10280	Front L.H. - Rear R.H. Straight Bearing Hanger - EZ410N Bearing	*
	DGA10281	Front R.H. - Rear L.H. Straight Bearing Hanger - EZ410N Bearing	*

15		Gang Bolts - 8" (203.2mm) Spacing	
	DGA86	6 Blade Gang Bolt - 47" (1194mm) Long	*
	DFA87	7 Blade Gang Bolt - 55-1/2" (1410mm) Long	*
	DGA88	8 Blade Gang Bolt - 64" (1626mm) Long	
	DGA89	9 Blade Gang Bolt - 72-1/4" (1835mm) Long	*
	DGA90	10 Blade Gang Bolt - 80-3/4" (2051mm) Long	*
	DGA91	11 Blade Gang Bolt - 89-1/2" (2273mm) Long	
	DGA92	12 Blade Gang Bolt - 97-1/4" (2470mm) Long	*
	DGA93	13 Blade Gang Bolt - 105-1/2" (2678mm) Long	*

Item	Part #	Description	Qty
	DGA94	14 Blade Gang Bolt - 113-3/4" (2889mm) Long	*
	DGA95	15 Blade Gang Bolt - 122-1/4" (3105mm) Long	*

		Gang Bolts - 9" (228.6mm) Spacing	
	DGA65	5 Blade Gang Bolt - 47" (1194mm) Long	*
	DGA66	6 Blade Gang Bolt - 55-1/2" (1410mm) Long	*
	DGA67	7 Blade Gang Bolt - 64" (1626mm) Long	*
	DGA68	8 Blade Gang Bolt - 72-1/4" (1835mm) Long	*
	DGA69	9 Blade Gang Bolt - 80-3/4" (2051mm) Long	*
	DGA70	10 Blade Gang Bolt - 89-1/2" (2273mm) Long	*
	DGA71	11 Blade Gang Bolt - 97-1/4" (2470mm) Long	*
	DGA72	12 Blade Gang Bolt - 105-1/2" (2678mm) Long	*
	DGA73	13 Blade Gang Bolt - 113-3/4" (2889mm) Long	*
	DGA74	14 Blade Gang Bolt - 122-1/4" (3105mm) Long	*

16	DGA35	Socket Wrench	1
17	DG6080	5/8" x 4" x 4-7/16" (15.9 x 101.6 x 112.7mm) Long U-Bolt	*
18	10GN1	1/4" (6.35mm) x 28 Grease Fitting	*
19	DG10310	7/16" x 3" (11 x 76.2mm) Lock Pin	*
20		1/2" x 2-1/4" N.C. (12.7 x 57.2mm) Hex Bolt - 211 Bearing	*
21		5/8" x 2-1/4" N.C. (15.9 x 57.2mm) Hex Bolt - 410 Bearing	*
		1/2" (12.7mm) Lockwasher - 211 Bearing	*
22		5/8" (15.9mm) Lockwasher - 410 Bearing	*
		1/2" (12.7mm) Hex Nut - 211 Bearing	*
23	DGA6091	5/8" (15.9mm) Hex Nut - 410 Bearing	*
	DGA6092	Front R.H. - Rear L.H. 2" Offset Hanger (50.8mm) - 211 Series	*
	DGA10282	Front L.H. - Rear R.H. 2" Offset Hanger (50.8mm) - 211 Series	*
	DGA10283	Front R.H. - Rear L.H. 2" Offset Hanger (50.8mm) - EZ410N Series	*
24	DGA5370	Front L.H. - Rear R.H. 2" Offset Hanger (50.8mm) - EZ410N Series	*
25	DGB5334	5-1/2" (139.7mm) Gang Washer - Weld-On	*
	DGB5363	211 Housing c/w Bearing & Grease Fitting	*
		EZ410N Housing c/w Bearing & Grease Fitting	

*As required

Stone Flex Hanger Assembly

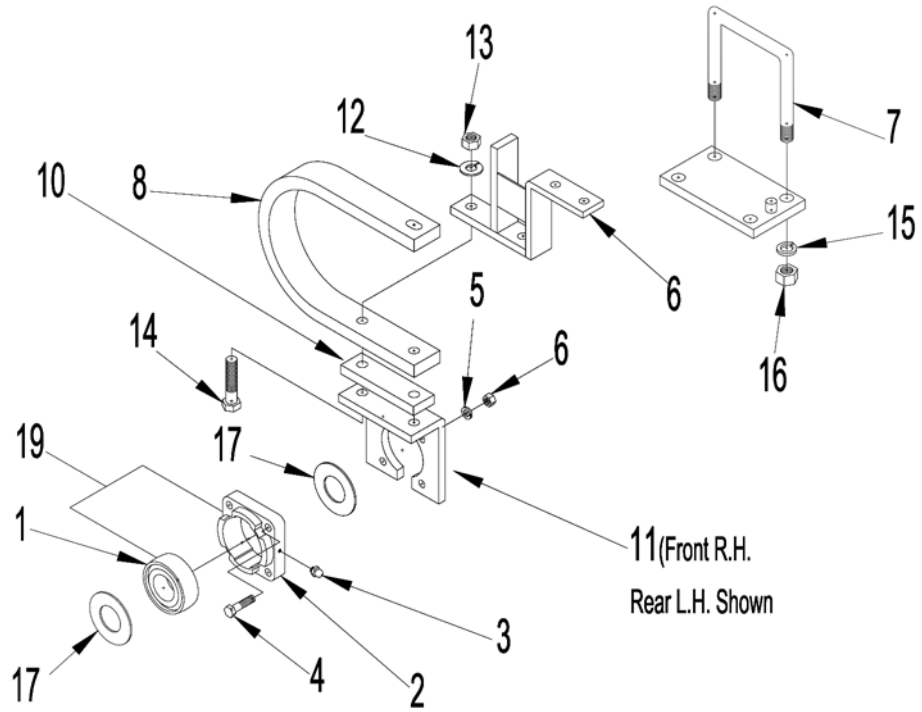

Item	Part #	Description	Qty
1	DG95	211 Series Greaseable Bearing	*
	DG38	EZ410N Series Greaseable Bearing	*
2	DG94	211 Bearing Housing Only	*
	DG96	EZ410N Bearing Housing Only	*
3	10GN1	1/4" x 23 (6.35mm) Grease Fitting	*
4		1/2" x 2-1/4" N.C. (12.7 x 57.2mm) Hex Bolt - 211 Bearing	*
		5/8" x 2-1/4" N.C. (15.9 x 57.2mm) Hex Bolt - EZ410N Bearing	*
5		1/2" (12.7mm) Lockwasher - 211 Bearing	*
		5/8" (15.9mm) Lockwasher - EZ410N Bearing	*
6		1/2" (12.7mm) Hex Nut - 211 Bearing	*
		5/8" (15.9mm) Hex Nut - EZ410 Bearing	*
7	DG0290	3/4" x 4" x 7" (19.1 x 101.6 x 177.8mm) Long U-Bolt	*
8	DG8150	1-1/4" x 2" (31.2 x 50.8mm) Spring Shank	*
9	DGA8612	L.H. Scraper Bar Support Bracket - STD Stone Flex Hanger	*
	DGA8611	R.H. Scraper Bar Support Bracket - STD Stone Flex Hanger	*
	DGA8623	Scraper Bar Support Bracket - Offset Stone Flex Hanger - Front L.H. or Rear R.H.	*
	DGA8624	Scraper Bar Support Bracket - Offset Stone Flex Hanger - Front R.H. or Rear L.H.	*
10	DGA10295	Backing Plate - Stone Flex Hanger - 3/4" (19.1mm) U-Bolt	*
11	DG5342	Bracket Mounting Front L.H. - Rear R.H. 211 Series - Std Stone Flex	*
	DG5343	Bracket Mounting Front R.H. - Rear L.H. 211 Series - Std Stone Flex	*
	DG5344	Bracket Mounting Front L.H. - Rear R.H. 211 Series - 2" (50.8mm) Offset Stone Flex Hanger	*
	DG5345	Bracket Mounting Front R.H. - Rear L.H. 211 Series - 2" (50.8mm) Offset Stone Flex Hanger	*
	DGA5324	Mounting Bracket - EZ410N Series - STD Stone Flex Hanger	*
	DGA5341	Mounting Bracket - EZ410N Series - 2" Offset Stone Flex Hanger	*
12		3/4" (15.9mm) Lockwasher	*
13		3/4" (15.9mm) N.C. Hex Nut	*
14		3/4" x 3-1/2" (15.9 x 88.9mm) N.C. Hex Bolt	*
15		3/4" (15.9mm) Lockwasher	*
16		3/4" (15.9mm) Hex Nut	*
17	DG236	3-5/8" O.D. x 2" I.D. x 1/16" (92. x 50.8 x 1.59mm) Bearing Shield - 211 Series	*
	DG237	4-1/2" O.D. x 2" I.D. x 1/16" (114 x 50.8 x 1.59mm) Bearing Shield - EZ410N	*
18	DG13510	Bearing Plate	*
19	DGB5334	211 Housing c/w Bearing & Grease Fitting	*
	DGB5335	EZ410N Housing c/w Bearing & Grease Fitting	*

*As required

Rockshaft Cylinder

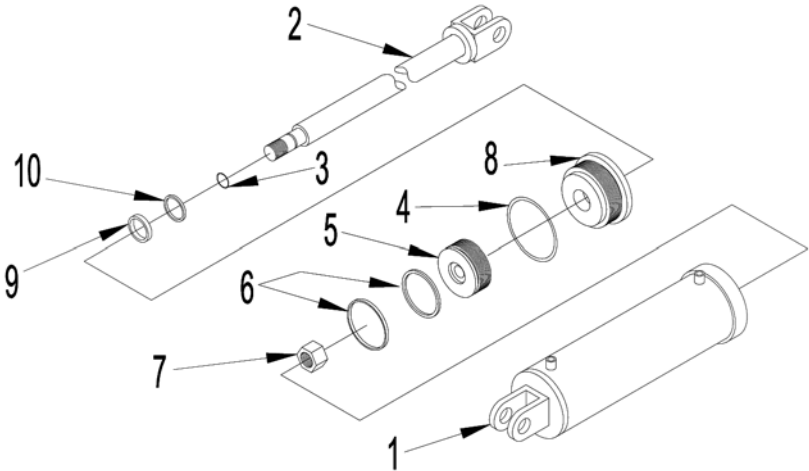

Item	Part #	Description	Qty
------	--------	-------------	-----

R.H. Main Rockshaft Cylinder - 4" x 24" (101.6 x 610mm) Rephasing Cylinder			
1	40TU10	Tube Assembly - 4" x 24" (101.6 x 610mm)	1
2	10SH60	Shaft - 2" x 24" (50.8 x 610mm)	1
3	10OR18	1" O.D. x 7/8" I.D. (25.4 x 22.2mm) O-Ring	1
4	10OR17	4" O.D. x 3/16" (101.6 x 4.76mm) O-Ring	1
5	40PB8	Piston - 4" O.D. x 1" I.D. (101.6 x 25.4mm)	1
6	40PS1	4" O.D. (101.6mm) Piston Seal Assembly	1
7	10NU4	1" (25.4mm) - 14 N.F. Hex Nut	1
8	40HP5	Head Plate - 4" O.D. x 2" I.D. (101.6 x 50.8mm)	1
9	1ORS2	Rod Seal - 2-3/8" O.D. x 2" I.D. x 3/8" (60.2 x 50.8 x 9.39mm)	1
10	10WS6	Wiper Seal - 2-1/2" O.D. x 2" I.D. x 3/8" (63.5 x 50.8 x 9.39mm) - All Urethane	1

L.H. Wing Rockshaft Cylinder - 3-1/2" x 24" (88.9 x 610mm) Rephasing Cylinder			
1	35TU15	Tube Assembly - 3-1/2" x 24" (88.9 x 610mm)	1
2	10SH59	Shaft - 1-3/4" x 24" (44.4 x 610mm)	1
3	10OR18	1" O.D. x 7/8" I.D. (25.4 x 22.2mm) O-Ring	1
4	10OR8	3-1/2" O.D. x 3/16" (88.9 x 4.76mm) O-Ring	1
5	35PB8	Piston - 3-1/2" O.D. x 1" I.D. (88.9 x 25.4mm)	1
6	35PS1	Piston Seal Assembly	1
7	10NU4	1" (25.4mm) - 14 N.F. Hex Nut	1
8	35HP9	Head Plate - 3-1/2" O.D. x 1-3/4" I.D. (88.9 x 44.4mm)	1
9	1ORS3	Rod Seal - 1-3/4" O.D. x 2-1/8" I.D. x 3/8" (44.4 x 54 x 9.39mm)	1
10	10WS10	Wiper Seal - 1-3/4" O.D. x 2-1/8" I.D. x 1/4" (44.4 x 54 x 6.35mm) - All Urethane	1

R.H. Wing Rockshaft Cylinder - 3" x 24" (76.2 x 610mm) Rephasing Cylinder			
1	30TU34	Tube Assembly - 3" x 24" (76.2 x 610mm)	1
2	10SH59	Shaft - 1-3/4" x 24" (44.4 x 610mm)	1
3	10OR18	1" O.D. x 7/8" I.D. (25.4 x 22.2mm) O-Ring	1
4	10OR3	3" O.D. x 3/16" (76.2 x 4.76mm) O-Ring	1
5	30PB4	Piston - 3" O.D. x 1" I.D. (76.2 x 25.4mm)	1
6	30PS1	Piston Seal Assembly	1
7	10NU4	1" (25.4mm) - 14 N.F. Hex Nut	1
8	30HP15	Head Plate - 3" O.D. x 1-3/4" I.D. (76.2 x 44.4mm)	1
9	1ORS3	Rod Seal - 1-3/4" O.D. x 2-1/8" I.D. x 3/8" (44.4 x 54 x 9.39mm)	1
10	10WS10	Wiper Seal - 1-3/4" O.D. x 2-1/8" I.D. x 1/4" (44.4 x 54 x 6.35mm) - All Urethane	1

Wing Lift Cylinder

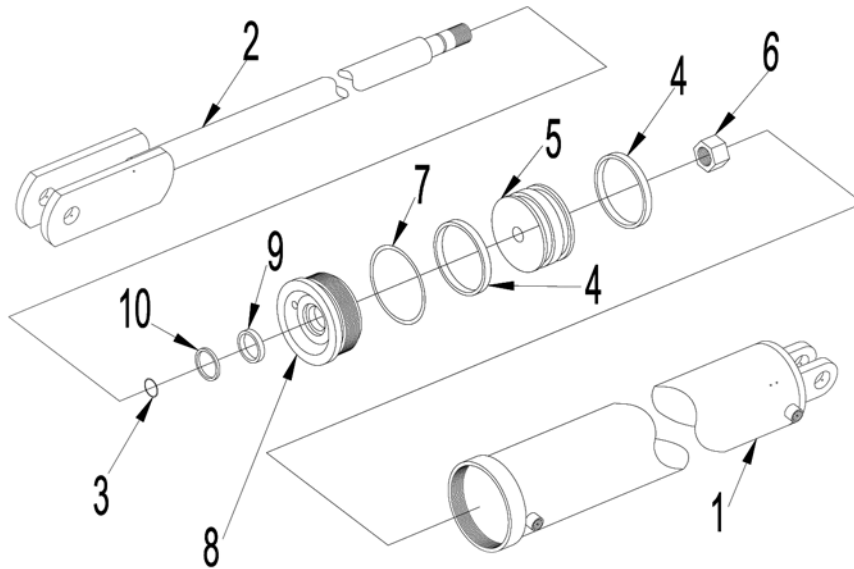

Item	Part #	Description	Qty
Wing Lift Cylinder - 5" x 36" (127 x 914mm)			
1	50TU8	Tube Assembly - 5" x 36" (127 x 914mm) for Cylinder #242	1
2	10SH36	Shaft - 1-3/4" x 36" (44.4 x 914mm) for 1-1/4" (31.8mm) Nut	1
3	10OR19	O-Ring - 1-1/8" I.D. x 1-1/4" O.D. (28.5 x 31.8mm) for 1-1/4" (31.8mm) Nut	1
4	50CU1	4-1/2" I.D. x 5" O.D. x 1/2" (29.9 x 127 x 12.7mm) U-Cup	2
5	50PB2	Piston - 5" O.D. (127mm) for 1-1/4" (31.8mm) Nut	1
6	10NU3	1-1/4" x 12 U.N.F. (31.8 x 305mm) Hex Lock Nut	1
7	10OR14	4-1/2" I.D. x 5" O.D. (29.9 x 127mm) O-Ring	1
8	50HP1	5" (127mm) Head Plate	1
9	10RS3	1-3/4" I.D. x 2-1/8" O.D. x 3/8 (44.4 x 54. x 9.39mm) Rod Seal	1
10	10WS3	1-3/4" I.D. x 2-1/8" O.D. x 3/16 (44.4 x 54. x 4.76mm) Wiper Seal	1

Item	Part #	Description	Qty
------	--------	-------------	-----

5017N4 Cylinder Seal			
	50CU1	4-1/2" I.D. x 5" O.D. x 1/2" (114 x 127 x 12.7mm) U-Cup	2
	100R14	4-1/2" I.D. x 5" O.D. (114 x 127mm) O-Ring	1
	100R19	1-1/8" I.D. x 1-1/4" O.D. (28.5 x 31.8mm) O-Ring w/1-1/4" Nut (31.8mm)	1
	10ORS3	1-3/4" I.D. x 2-1/8" O.D. x 3/8" (44.4 x 54. x 9.39mm) Rod Seal	1
	10WS3	1-3/4" I.D. x 2-1/8" O.D. x 3/16" (44.4 x 54 x 4.76mm) Wiper Seal	1
	100R13	1" I.D. x 1-1/4" O.D. O-Ring w/ 1" Nut (25.4mm)	1

4020N4-0 Cylinder Seal			
	100R18	1" O.D. x 7/8" I.D. (25.4 x 22.2mm) O-Ring	1
	100R17	4" O.D. x 3/16" (101.6 x 4.76mm) O-Ring	1
	40PS1	4" (101.6mm) Piston Seal Assembly	1
	10RS2	2-3/8" O.D. x 2" I.D. x 3/8" (60.2 x 50.8. x 9.39mm) Rod Seal	1
	10WS6	2-1/2" O.D. x 2" I.D. x 3/8" (63.5 x 50.8. x 9.39mm) Wiper Seal - Urethane	1

3517N4-0 Cylinder Seal			
	100R18	1" O.D. x 7/8" I.D. (25.4 x 22.2mm) O-Ring	1
	100R8	3-1/2" O.D. x 3/16" (88.9 x 4.76mm) O-Ring	1
	35PS1	3-1/2" (88.9mm) Piston Seal Assembly	1
	10RS3	1-3/4" I.D. x 2-1/8" O.D. x 3/8" (44.4 x 54.0. x 9.39mm) Rod Seal	1
	10WS10	1-3/4" I.D. x 2-1/8" O.D. x 1/4" (44.4 x 54. x 6.35mm) Wiper Seal - Urethane	1

4020N4-0 Cylinder Seal			
	100R18	1" O.D. x 7/8" I.D. (25.4 x 22.2mm) O-Ring	1
	100R3	3" O.D. x 3/16" (76.2 x 4.76mm) O-Ring	1
	30PS1	3" (76.2mm) Piston Seal Assembly	1
	10RS3	1-3/4" I.D. x 2-1/8" O.D. x 3/8" (44.4 x 54.0. x 9.39mm) Rod Seal	1
	10WS10	1-3/4" I.D. x 2-1/8" O.D. x 1/4" (44.4 x 54. x 6.35mm) Wiper Seal - Urethane	1

Light Kit Assembly

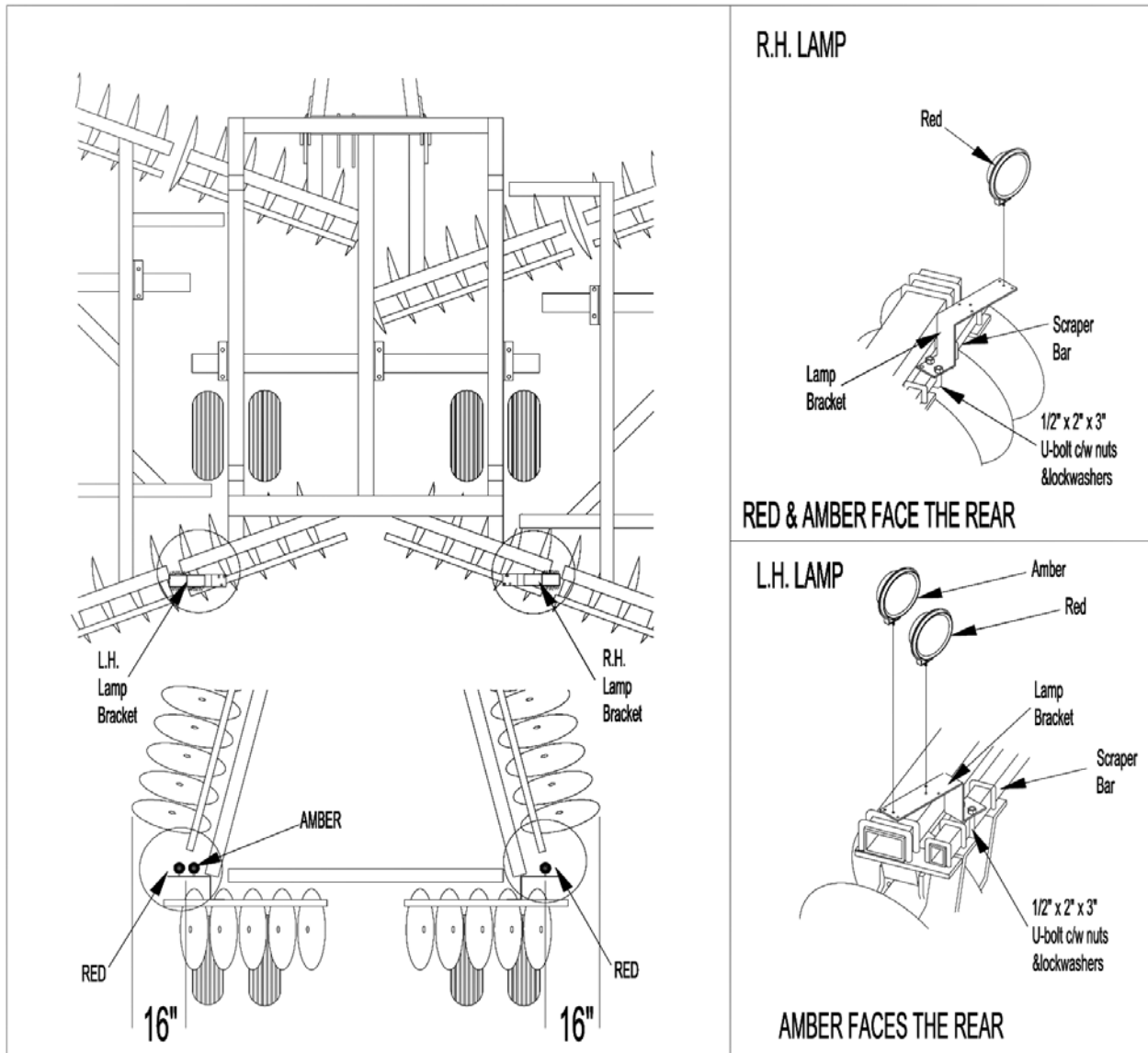

Item	Part #	Description	Qty

*As required

Need a parts list for here

Farm King Limited Warranty

This document limits your warranty rights.

Base Limited Warranty

Buhler Industries Inc. provides this warranty only to original retail purchasers of its product. Buhler Industries Inc. warrants to such purchasers that all Buhler Industries Inc. manufactured parts and components used and serviced as provided for in the Operator's Manual shall be free from defects in materials and workmanship for a period following delivery to the original retail purchaser of 12 months (80 days for commercial applications). This limited warranty applies only to those parts and components manufactured by Buhler Industries Inc. Parts and components manufactured by others are subject to their manufacturer's warranties, if any.

Buhler Industries Inc. will fulfill this limited warranty by, at its option, repairing or replacing any covered part that is defective or is the result of improper workmanship, provided that the part is returned to Buhler Industries Inc. within thirty (30) days of the date that such defect or improper workmanship is, or should have been, discovered. Buhler Industries Inc. reserves the right to either inspect the product at the buyer's location or have it returned to the factory for inspection. Parts must be returned through the selling representative and the buyer must prepay transportation charges.

Buhler Industries Inc. will not be responsible for repairs or replacements that are necessitated, in whole or part, by the use of parts not manufactured by or obtained from Buhler Industries Inc. Under no circumstances are component parts warranted against normal wear and tear. There is no warranty on product pump seals, product pump bearings, rubber product hoses, pressure gauges, or other components that require replacement as part of normal maintenance. Also: Buckets and Bucket Tines carry no warranty, Bent Spears carry no warranty, Snowblower Fan Shafts carry no warranty, Mower Blades carry no warranty, Portable Auger Parts Have Two (2) Year Warranty, Loader Parts Have Two (2) Year Warranty. The purchaser is solely responsible for determining suitability of goods sold. This warranty is expressly in lieu of all other warranties expressed or implied. Buhler Industries Inc. will in no event be liable for any incidental or consequential damages whatsoever. Nor for any sum in excess of the price received for the goods for which liability is claimed.

Repair Parts Limited Warranty

Buhler Industries Inc. warrants Farm King replacement parts purchased after the expiration of the Buhler Industries Inc. Limited Warranty, and used and serviced as provided for in the Operator's Manual, to be free from defects in materials or workmanship for a period of thirty (30) days from the invoice date for the parts. Buhler Industries Inc. will fulfill this limited warranty by, at its option, repairing or replacing any covered part that is defective or is the result of improper workmanship, provided that the part is returned to Buhler Industries Inc. within thirty (30) days of the date that such defect or improper workmanship is, or should have been, discovered. Such parts must be shipped to Buhler Industries Inc. at the purchaser's expense.

What is Not Covered

Under no circumstances does this limited warranty cover any components or parts that have been subject to the following: negligence; alteration or modification not approved by Buhler Industries Inc.; misuse; improper storage; lack of reasonable and proper maintenance, service, or repair; normal wear; damage from failure to follow operating instructions; accident; and/or repairs that have been made with parts other than those manufactured, supplied, and or authorized by Buhler Industries Inc.

Authorized Dealer and Labor Costs

Repairs eligible for labor under this limited warranty must be made by Buhler Industries Inc. or an authorized Farm King dealer. Buhler Industries Inc. retains the exclusive discretion to determine whether it will pay labor costs for warranty repairs or replacements, and the amount of such costs that it will pay and the time in which the repairs will be made. If Buhler Industries Inc. determines that it will pay labor costs for warranty work, it will do so by issuing a credit to the dealer's or distributor's account. Buhler Industries Inc. will not approve or pay invoices sent for repairs that Buhler Industries Inc. has not previously approved. Warranty service does not extend the original term of this limited warranty.

Warranty Requirements

To be covered by warranty, each Farm King new product must be registered with Buhler Industries Inc. within thirty (30) days of delivery to original retail purchaser. If the customer decides to purchase replacement components before the warranty disposition of such components is determined, Buhler Industries Inc. will bill the customer for such components and then credit the replacement invoice for those components later determined to be covered by this limited warranty. Any such replacement components that are determined not be covered by this limited warranty will be subject to the terms of the invoice and shall be paid for by the purchaser.

Warranty Claims:

Warranty requests must be prepared on Buhler Industries Inc. Warranty Claim Forms with all requested information properly completed. Warranty Claims must be submitted within a thirty (30) day period from date of failure repair.

Warranty Labor:

Any labor subject to warranty must be authorized by Buhler Industries Inc. The labor rate for replacing defective parts, where applicable, will be credited at 100% of the dealer's posted shop rate.

Exclusive Effect of Warranty and Limitation of Liability

TO THE EXTENT PERMITTED BY LAW, BUHLER INDUSTRIES INC. DISCLAIMS ANY WARRANTIES, REPRESENTATIONS, OR PROMISES, EXPRESS OR IMPLIED, AS TO THE QUALITY, PERFORMANCE, OR FREEDOM FROM DEFECT OF THE COMPONENTS AND PARTS COVERED BY THIS WARRANTY AND NOT SPECIFICALLY PROVIDED FOR HEREIN.

TO THE EXTENT PERMITTED BY LAW, BUHLER INDUSTRIES INC. DISCLAIMS ANY IMPLIED WARRANTIES OF MERCHANTABILITY AND FITNESS FOR A PARTICULAR PURPOSE ON ITS PRODUCTS COVERED HEREIN, AND DISCLAIMS ANY RELIANCE BY THE PURCHASER ON BUHLER INDUSTRIES INC.'S SKILL OR JUDGMENT TO SELECT OR FURNISH GOODS FOR ANY PARTICULAR PURPOSE. THE PURCHASER'S ONLY AND EXCLUSIVE REMEDIES IN CONNECTION WITH THE BREACH OR PERFORMANCE OF ANY WARRANTY ON PRODUCTS MANUFACTURED BY BUHLER INDUSTRIES INC. ARE THOSE SET FORTH HEREIN. IN NO EVENT SHALL BUHLER INDUSTRIES INC. BE LIABLE FOR INCIDENTAL OR CONSEQUENTIAL DAMAGES (INCLUDING, BY WAY OF EXAMPLE ONLY AND NOT LIMITATION, LOSS OF CROPS, LOSS OF PROFITS OR REVENUE, OTHER COMMERCIAL LOSSES, INCONVENIENCE, OR COST OF REPLACEMENT OF RENTAL EQUIPMENT). IN NO EVENT SHALL FARM KING'S CONTRACT OR WARRANTY LIABILITY EXCEED THE PURCHASE PRICE OF THE PRODUCT.

(Note that some provinces or states do not allow limitations on how long an implied warranty lasts or the exclusion or limitation of incidental or consequential damages, so the above limitations and exclusion may not apply to you.) This warranty gives you specific legal rights and you may also have other rights, which vary from province to province or state to state.

Buhler Industries Inc. neither assumes nor authorizes any person or entity, including its selling representatives, to assume any other obligations or liability in connections with the sale of covered equipment, or to make any other warranties, representations, or promises, express or implied, as to the quality, performance, or freedom from defect of the components and parts covered herein. No one is authorized to alter, modify, or enlarge this limited warranty, or its exclusions, limitations and reservations.

Corrections of defects and improper workmanship in the manner, and for the applicable time periods, provided for herein shall constitute fulfillment of all responsibilities of Buhler Industries Inc. to the purchaser, and Buhler Industries Inc. shall not be liable in negligence, contract, or on any other basis with respect to the subject equipment.

This limited warranty is subject to any existing conditions of supply which may directly affect Buhler Industries Inc.'s ability to obtain materials or manufacture replacement parts.

Buhler Industries Inc. reserves the right to make improvements in design or changes in specifications to its products at anytime, without incurring any obligation to owners of units previously sold.

Government Legislation:

Warranty terms and conditions are subject to provincial or state legislation.

Important Note: This warranty does not apply to rentals.

www.farm-king.com

Farm King

5110 - 62nd Street
Vegreville, Alberta Canada, T9C 1N6
Ph.: 204.822.4467 | Fax: 204.822.6348
Toll Free: 888.524.1004
E-mail: info@buhler.com
www.farm-king.com

Equipment shown is subject to change without notice.
©2011 Buhler Trading Inc. Printed in Canada TSX:BUI

bühler | a division of Buhler Industries Inc.