

Robex

125 LCR-9A

With Tier 4 Interim Engine installed

MOVING YOU FURTHER

HYUNDAI HEAVY INDUSTRIES



*Photo may include optional equipment.

 **HYUNDAI**
HEAVY INDUSTRIES CO., LTD.

Dimensions & Working Range

R125LCR-9A

Engine	Power (Net)	ps / rpm	93 / 1,900	Drawbar Pull	Kgf	10,300	
	Max. Torque	Kgf-m / rpm	45.9 / 1,400		Hydraulic System	Pressure	Kg / cm ²
	Displacement	cc	4,400	Flow		ℓ / min	2 x 123.5
Swing Speed	rpm	12.6	Tank Capa	Fuel	ℓ	210	
Traver Speed (low / high)	km / hr	3.6 / 6.1		Hyd.(system)	ℓ	80 (160)	
Gradeability	Deg	35					

R125LCR-9A DIMENSIONS

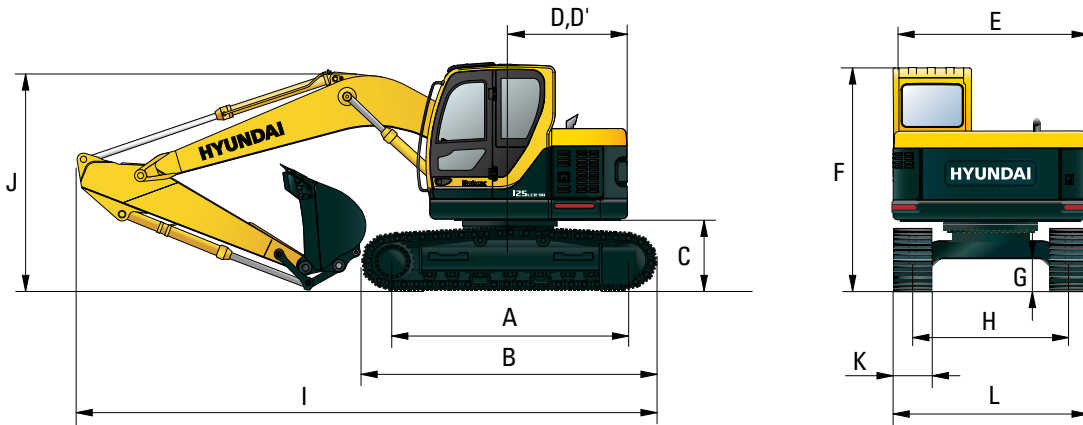

mm (ft-in)

A	Tumbler distance	2,780 (9' 1")	Boom length	4,300(15' 1")			
B	Overall length of crawler	3,550 (11' 6")	Arm length	2,260 (7' 4")	1,960 (6' 4")		
C	Ground clearance of counterweight	890 (2' 9")	I	Overall length	6,860 (22' 5")	6,840 (22' 4")	
D	Tail swing radius	1,490 (4' 8")	J	Overall height of boom	2,740 (8' 9")	2,530 (8' 3")	
D'	Rear-end length	1,490 (4' 8")	K	Track shoe width	500 (20")	600 (24")	700 (28")
E	Overall width of upperstructure	2,490 (8' 1")	L	Overall width	2,490 (8' 1")	2,600 (8' 6")	2,700 (8' 10")
F	Overall height of cab	2,900 (9' 5")					
G	Min. ground clearance	440 (1' 4")					
H	Track gauge	1,990 (6' 2")					

R125LCR-9A WORKING RANGE

mm (ft-in)

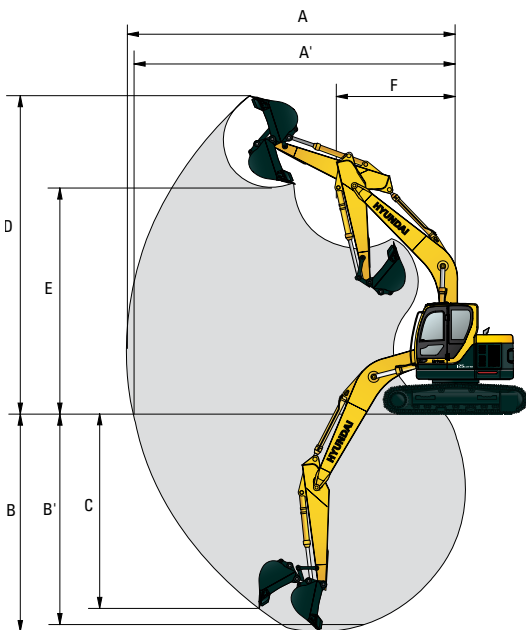

	Boom length	4,300(15' 1")	
	Arm length	2,260 (7' 4")	1,960 (6' 4")
A	Max. digging reach	7,700 (25' 2")	7,420 (24' 3")
A'	Max. digging reach on ground	7,560 (24' 8")	7,270 (23' 8")
B	Max. digging depth	5,060 (16' 6")	4,760 (15' 6")
B'	Max. digging depth (8' level)	4,830 (15' 8")	4,500 (14' 7")
C	Max. vertical wall digging depth	4,410 (14' 5")	4,140 (13' 5")
D	Max. digging height	8,100 (26' 5")	7,910 (25' 9")
E	Max. dumping height	5,740 (18' 8")	5,550 (18' 2")
F	Min. swing radius	2,340 (7' 6")	2,280 (7' 4")