

WALLENSTEIN

BY EMB MFG INC.



COMMERCIAL TRAILER WOOD CHIPPER MODEL CR60

OPERATOR'S MANUAL

WALLENSTEIN COMMERCIAL TRAILER WOOD CHIPPER

WARRANTY

This product is warranted to be free of defects in materials and workmanship under normal use and service, for a period of one year from the date of purchase, when operated and maintained in accordance with the Operating and Maintenance Instructions supplied with this unit. This warranty does not cover misuse or negligence.

Under no circumstances will the manufacturer be liable for any consequential damage or expense of any kind, including loss of profits. The manufacturer is under no circumstances liable for tractor damage of any kind. The manufacturer is not liable for the maintenance of the product.

This warranty is extended only to the original purchaser. Warranty is void if repairs are attempted by anyone other than an Authorized Service Centre.

If a difficulty develops with the product, you should contact your nearest Authorized Repair Centre, or distributor. Only these locations are authorized to make repairs to the product or affect the replacement of defective parts, which will be done at no charge within a reasonable time after the receipt of the product. Unit or parts should be returned at the customer's expense to the nearest repair location or Authorized Service Centre. Damage in-transit is not covered by warranty. Include original purchase receipt with any claim (keeping a copy for your files).

The distributor's liability under warranty is limited to repair of the product and/or replacement of parts and is given to the purchaser in lieu of all other remedies including incidental and consequential charges. There are no warranties, expressed or implied other than those specified herein. For the nearest Authorized Service Centre call the manufacturer. For Kohler engine service contact your local Kohler dealer or www.Kohler.ca.

EMB Manufacturing Inc.
4144 Boomer Line
St. Clements, ON
N0B 2M0 Canada
Phone: 519-699-9283
Fax: 519-699-4146

WARRANTY VOID IF NOT REGISTERED

WALLENSTEIN COMMERCIAL TRAILER WOOD CHIPPER

WARRANTY REGISTRATION FORM & INSPECTION REPORT

WARRANTY REGISTRATION (please print)

This form must be filled out by the dealer and signed by both the dealer and the customer at the time of delivery.

Customer's Name _____	Dealer Name _____
Address _____	Address _____
City, State/Province, Code _____	City, State/Province, Code _____
Phone Number (____) _____	Phone Number (____) _____
Contact Name _____	
Model _____	
Serial Number _____	
Delivery Date _____	

DEALER INSPECTION REPORT

Check Blade Clearance
 Rotor Turns Freely
 Belt Tension Checked
 Pulleys Aligned
 Fasteners Tight
 Lubricate Machine
 Check Tire Pressure
 Retainer Installed Through Ball Hitch Mechanism
 Check Engine Fluid Levels

SAFETY

Safety Chain on Hitch
 All Decals Installed
 Guards and Shields Installed and Secured
 Review Operating and Safety Instructions

I have thoroughly instructed the buyer on the above described equipment which review included the Operator's Manual content, equipment care, adjustments, safe operation and applicable warranty policy.

Date _____ Dealer's Rep. Signature _____

The above equipment and Operator's Manual have been received by me and I have been thoroughly instructed as to care, adjustments, safe operation and applicable warranty policy.

Date _____ Owner's Signature _____

WHITE	YELLOW	PINK
EMB MFG., INC	DEALER	CUSTOMER

SERIAL NUMBER LOCATION

Always give your dealer the serial number of your Wallenstein Commercial Trailer Wood Chipper when ordering parts or requesting service or other information.

The serial number plates are located where indicated. Please mark the numbers in the spaces provided for easy reference.



Machine



Engine

SERIAL NUMBER LOCATION

Model Number _____

Chipper Serial Number _____

Engine Serial Number _____

TABLE OF CONTENTS

SECTION	DESCRIPTION	PAGE
1	Introduction	1
2	Safety	2
2.1	General Safety	3
2.2	Equipment Safety Guidelines	4
2.3	Safety Training	5
2.4	Safety Signs	5
2.5	Preparation	6
2.6	Maintenance Safety	6
2.7	Operation Safety	7
2.8	Hydraulic Safety	8
2.9	Storage Safety	8
2.10	Transport Safety	8
2.11	Gas Motor Safety	9
2.12	Refueling Safety	10
2.13	Tire Safety	10
2.14	Battery Safety	10
2.15	Employee Sign-Off Form	11
3	Safety Sign Locations	12
4	Operation	16
4.1	To the New Operator or Owner	16
4.2	Machine Components	17
4.3	Machine Break-In	18
4.4	Pre-Operation Checklist	18
4.5	Controls	19
4.6	Attaching/Unhooking	23
4.7	Field Operation	25
4.8	Transporting	38
4.9	Storage	39
5	Service and Maintenance	40
5.1	Service	40
5.2	Maintenance	48
6	Troubleshooting	52
7	Specifications	54
7.1	Mechanical	54
7.2	Bolt Torque	55
7.3	Hydraulic Fitting Torque	56
8	Index	57

1 INTRODUCTION

Congratulations on your choice of an Wallenstein Commercial Trailer Wood Chipper to compliment your operation. This equipment has been designed and manufactured to meet the needs of a discerning timber or landscaping industry.

Safe, efficient and trouble free operation of your Wallenstein Wood Chipper requires that you and anyone else who will be using or maintaining the chipper, read and understand the Safety, Operation, Maintenance and Trouble Shooting information contained within the Operator's Manual.



CR60

This manual covers the Wallenstein Commercial Trailer Wood Chipper CR60. Use the Table of Contents or Index as a guide to locate required information.

Keep this manual handy for frequent reference and to pass on to new operators or owners. Call your Wallenstein dealer or the Distributer if you need assistance, information or additional copies of the manuals.

OPERATOR ORIENTATION - The directions left, right, front and rear, as mentioned throughout this manual, are determined when sitting in the pick-up driver's seat and facing in the direction of travel.

2 SAFETY

SAFETY ALERT SYMBOL

This Safety Alert symbol means
ATTENTION! BECOME ALERT!
YOUR SAFETY IS INVOLVED!

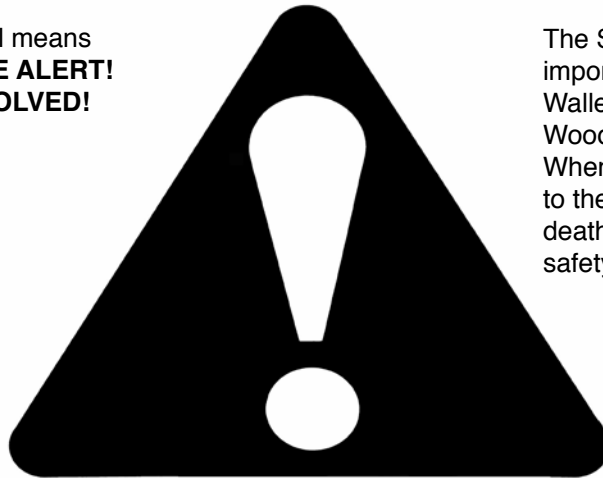

The Safety Alert symbol identifies important safety messages on the Wallenstein Commercial Trailer Wood Chipper and in the manual. When you see this symbol, be alert to the possibility of personal injury or death. Follow the instructions in the safety message.

Why is SAFETY important to you?

3 Big Reasons

Accidents Disable and Kill
Accidents Cost
Accidents Can Be Avoided

SIGNAL WORDS:

Note the use of the signal words **DANGER**, **WARNING** and **CAUTION** with the safety messages. The appropriate signal word for each message has been selected using the following guide-lines:

DANGER - Indicates an imminently hazardous situation that, if not avoided, will result in death or serious injury. This signal word is to be limited to the most extreme situations typically for machine components which, for functional purposes, cannot be guarded.

WARNING - Indicates a potentially hazardous situation that, if not avoided, could result in death or serious injury, and includes hazards that are exposed when guards are removed. It may also be used to alert against unsafe practices.

CAUTION - Indicates a potentially hazardous situation that, if not avoided, may result in minor or moderate injury. It may also be used to alert against unsafe practices.

If you have any questions not answered in this manual or require additional copies or the manual is damaged, please contact your dealer or Wallenstein, 4144 Boomer Line, St. Clements, ON, N0B 2M0. Phone (519) 669-9283 or Fax (519) 699-4146.

SAFETY

YOU are responsible for the SAFE operation and maintenance of your Wallenstein Commercial Trailer Wood Chipper. **YOU** must ensure that you and anyone else who is going to use, maintain or work around the Commercial Trailer Wood Chipper be familiar with the using and maintenance procedures and related **SAFETY** information contained in this manual. This manual will take you step-by-step through your working day and alerts you to all good safety practices that should be used while using the Commercial Trailer Wood Chipper.

Remember, **YOU** are the key to safety. Good safety practices not only protect you but also the people around you. Make these practices a working part of your safety program. Be certain that **EVERYONE** using this equipment is familiar with the recommended using and maintenance procedures and follows all the safety precautions. Most accidents can be prevented. Do not risk injury or death by ignoring good safety practices.

- Commercial Trailer Wood Chipper owners must give operating instructions to operators or employees before allowing them to operate the machine, and at least annually thereafter.
- The most important safety device on this equipment is a SAFE operator. It is the operator's responsibility to read and understand ALL Safety and Operating instructions in the manual and to follow these. Most accidents can be avoided.
- A person who has not read and understood all using and safety instructions is not qualified to use the machine. An untrained operator exposes himself and bystanders to possible serious injury or death.
- Do not modify the equipment in any way. Unauthorized modification may impair the function and/or safety and could affect the life of the equipment.
- Think SAFETY! Work SAFELY!

2.1 GENERAL SAFETY

1. Read and understand the Operator's Manual and all safety signs before using, maintaining, adjusting or cleaning the Trailer Wood Chipper.



2. Have a first-aid kit available for use should the need arise and know how to use it.

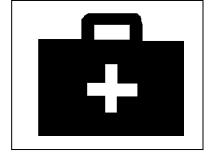

3. Have a fire extinguisher available for use should the need arise and know how to use it.

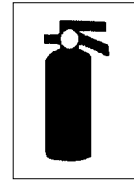

4. Do not allow riders.

5. Wear appropriate protective gear. This list includes but is not limited to:



- A hard hat
- Protective shoes with slip resistant soles
- Protective glasses, goggles or face shield
- Heavy gloves
- Wet weather gear
- Hearing Protection
- Respirator or filter mask

6. Install and secure all guards before starting.

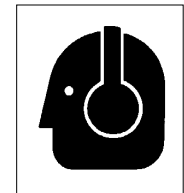

7. Wear suitable ear protection for prolonged exposure to excessive noise.

8. Turn machine off, stop and disable engine, remove ignition key and place in your pocket, set park brake and wait for all moving parts to stop before servicing, adjusting, repairing or unplugging.

9. Clear the area of people, especially small children, before using the unit.

10. Review safety related items annually with all personnel who will be operating or maintaining the Trailer Wood Chipper.

2.2 EQUIPMENT SAFETY GUIDELINES

1. Safety of the operator and bystanders is one of the main concerns in designing and developing equipment. However, every year many accidents occur which could have been avoided by a few seconds of thought and a more careful approach to handling equipment. You, the operator, can avoid many accidents by observing the following precautions in this section. To avoid personal injury or death, study the following precautions and insist those working with you, or for you, follow them.
2. In order to provide a better view, certain photographs or illustrations in this manual may show an assembly with a safety shield removed. However, equipment should never be used in this condition. Keep all shields in place. If shield removal becomes necessary for repairs, replace the shield prior to use.
3. Replace any safety sign or instruction sign that is not readable or is missing. Location of such safety signs is indicated in this manual.
4. Never use alcoholic beverages or drugs which can hinder alertness or coordination while using this equipment. Consult your doctor about using this machine while taking prescription medications.
5. **Under no circumstances should young children be allowed to work with this equipment. Do not allow persons to use or assemble this unit until they have read this manual and have developed a thorough understanding of the safety precautions and of how it works.** Review the safety instructions with all users annually.
6. This equipment is dangerous to children and persons unfamiliar with its operation. The operator should be a responsible, properly trained and physically able person familiar with machinery and trained in this equipment's operations. If the elderly are assisting with work, their physical limitations need to be recognized and accommodated.
7. Never exceed the limits of a piece of machinery. If its ability to do a job, or to do so safely, is in question - **DON'T TRY IT.**
8. Do not modify the equipment in any way. Unauthorized modification may result in serious injury or death and may impair the function and life of the equipment.
9. In addition to the design and configuration of this implement, including Safety Signs and Safety Equipment, hazard control and accident prevention are dependent upon the awareness, concern, prudence, and proper training of personnel involved in the operation, transport, maintenance, and storage of the machine. Refer also to Safety Messages and operation instruction in each of the appropriate sections of the engine and machine manuals. Pay close attention to the Safety Signs affixed to the tow vehicle and the machine.

2.3 SAFETY TRAINING

1. Safety is a primary concern in the design and manufacture of our products. Unfortunately, our efforts to provide safe equipment can be wiped out by a single careless act of an operator or bystander.
2. In addition to the design and configuration of equipment, hazard control and accident prevention are dependent upon the awareness, concern, prudence and proper training of personnel involved in the operation, transport, maintenance and storage of this equipment.
3. It has been said, "The best safety feature is an informed, careful operator." We ask you to be that kind of an operator. It is the operator's responsibility to read and understand ALL Safety and Using instructions in the manual and to follow these. Accidents can be avoided.
4. **Working with unfamiliar equipment can lead to careless injuries. Read this manual before assembly or using, to acquaint yourself with the machine. If this machine is used by any person other than yourself, or is loaned or rented, it is the machine owner's responsibility to make certain that the operator, prior to using:**
 - a. **Reads and understands the operator's manuals.**
 - b. **Is instructed in safe and proper use.**
5. Know your controls and how to stop tow unit, engine and machine quickly in an emergency. Read this manual and the one provided with your engine.
6. Train all new personnel and review instructions frequently with existing workers. Be certain only a properly trained and physically able person will use the machinery. A person who has not read and understood all using and safety instructions is not qualified to use the machine. An untrained operator exposes himself and bystanders to possible serious injury or death. If the elderly are assisting with the work, their physical limitations need to be recognized and accommodated.

2.4 SAFETY SIGNS

1. Keep safety signs clean and legible at all times.
2. Replace safety signs that are missing or have become illegible.
3. Replaced parts that displayed a safety sign should also display the current sign.
4. Safety signs displayed in Section 3 each have a part number in the lower right hand corner. Use this part number when ordering replacement parts.
5. Safety signs are available from your authorized Distributor or Dealer Parts Department or the factory.

How to Install Safety Signs:

- Be sure that the installation area is clean and dry.
- Be sure temperature is above 50°F (10°C).
- Determine exact position before you remove the backing paper.
- Remove the smallest portion of the split backing paper.
- Align the sign over the specified area and carefully press the small portion with the exposed sticky backing in place.
- Slowly peel back the remaining paper and carefully smooth the remaining portion of the sign in place.
- Small air pockets can be pierced with a pin and smoothed out using the piece of sign backing paper.

2.5 PREPARATION

1. Never use the engine and machine until you have read and completely understand this manual, the Engine Operator's Manual and each of the Safety Messages found on the safety signs on the engine and machine.

2. Personal protection equipment including hard hat, safety glasses, safety shoes, and gloves are recommended during assembly,



installation, operation, adjustment, maintaining, repairing, removal, cleaning, or moving the unit. Do not allow long hair, loose fitting clothing or jewellery to be around equipment.

3. **PROLONGED EXPOSURE TO LOUD NOISE MAY CAUSE PERMANENT HEARING LOSS!**

Power equipment with or without equipment attached can often be noisy enough to cause permanent, partial hearing loss. We recommend that you wear hearing protection on a full-time basis if the noise in the Operator's position exceeds 80db. Noise over 85db on a long-term basis can cause severe hearing loss. Noise over 90db adjacent to the Operator over a long-term basis may cause permanent, total hearing loss. **NOTE:** Hearing loss from loud noise (from tractors, chain saws, radios, and other such sources close to the ear) is cumulative over a lifetime without hope of natural recovery.

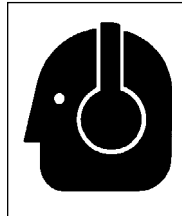

4. Clear working area of stones, branches or hidden obstacles that might be hooked or snagged, causing injury or damage.
5. Use only in daylight or good artificial light.
6. Be sure machine is properly mounted, adjusted and in good operating condition.
7. Ensure that all safety shielding and safety signs are properly installed and in good condition.

2.6 MAINTENANCE SAFETY

1. Good maintenance is your responsibility. Poor maintenance is an invitation to trouble.
2. Follow good shop practices.

- Keep service area clean and dry.
- Be sure electrical outlets and tools are properly grounded.
- Use adequate light for the job at hand.



3. Make sure there is plenty of ventilation. Never operate the engine of the towing vehicle in a closed building. The exhaust fumes may cause asphyxiation.
4. Before working on this machine, shut off the engine, set the brake, and turn fuel valve off.
5. Never work under equipment unless it is blocked securely.
6. Always use personal protection devices such as eye, hand and hearing protectors, when performing any service or maintenance work. Use heavy or leather gloves when handling blades.
7. Where replacement parts are necessary for periodic maintenance and servicing, genuine factory replacement parts must be used to restore your equipment to original specifications. The manufacturer will not be responsible for injuries or damages caused by use of unapproved parts and/or accessories.

8. A fire extinguisher and first aid kit should be kept readily accessible while performing maintenance on this equipment.

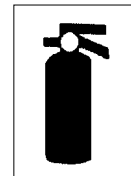
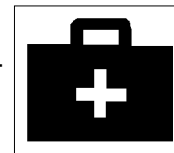

9. Periodically tighten all bolts, nuts and screws and check that all electrical and fuel connections are properly secured to ensure unit is in a safe condition.
10. When completing a maintenance or service function, make sure all safety shields and devices are installed before placing unit in service.

2.7 OPERATING SAFETY

1. Please remember it is important that you read and heed the safety signs on the Commercial Trailer Wood Chipper. Clean or replace all safety signs if they cannot be clearly read and understood. They are there for your safety, as well as the safety of others. The safe use of this machine is strictly up to you, the operator.
2. All things with moving parts are potentially hazardous. There is no substitute for a cautious, safe-minded operator who recognizes potential hazards and follows reasonable safety practices. The manufacturer has designed this Commercial Trailer Wood Chipper to be used with all its safety equipment properly attached, to minimize the chance of accidents. Study this manual to make sure you have all safety equipment attached.
3. Close and secure rotor cover before operating.
4. Close and secure all guards, deflectors and shields before starting and operating.
5. Read and understand operator's manual before starting. Review safety instructions annually.
6. Personal protection equipment including hearing protection, hard hat, safety glasses, safety shoes, and gloves are recommended during assembly, installation, operation, adjustment, maintaining, repairing, removal, or moving. Do not allow long hair, loose-fitting clothing, or jewellery to be around moving parts.
7. Keep hydraulic lines and fittings tight, in good condition and free of leaks.
8. Keep electrical harness, sensors and controller in good condition before operating to maintain control.
9. Never place any part of your body where it would be in danger if movement should occur during assembly, installation, operation, maintenance, repairing, unplugging or moving.
10. Turn machine off, stop and disable engine, remove ignition key and place in your pocket, set park brake and wait for all moving parts to stop before servicing, adjusting, repairing or unplugging.
11. Do not run machine inside a closed building to prevent asphyxiation from engine exhaust.
12. Use care when feeding material into chipper. Do not send metal, bottles, cans, rocks, glass or other foreign material into wood chipper. If foreign material enters chipper, stop machine, turn engine off and place ignition key in your pocket and wait for all moving parts to stop before removing material and/or unplugging. Inspect machine for damaged or loose parts before resuming work.
13. Never use alcoholic beverages or drugs which can hinder alertness or coordination while operating this equipment. Consult your doctor about operating this machine while taking prescription medications.
14. Do not allow riders on this machine at any time. There is no safe place for any riders.
15. Never allow children or unauthorized people to operate or be around this machine.
16. Do not reach into rotor or feed hopper openings when the engine is running. Install and secure access covers before starting engine.
17. Keep the working area clean and free of debris to prevent tripping. Operate only on level ground.
18. Do not point discharge at people, animals or buildings. Rotor can expel wood chips fast enough to cause injury.
19. Do not move or transport chipper when the rotor is turning.
20. Do not exceed a safe travel speed when transporting. Cross safety chain under hitch on trailer model when attaching to truck.

2.8 HYDRAULIC SAFETY

1. Make sure that all the components in the hydraulic system are kept in good condition and are clean.
2. Before applying pressure to the system, make sure all components are tight, and that lines, hoses and couplings are not damaged.
3. Do not attempt any makeshift repairs to the hydraulic lines, fittings or hoses by using tapes, clamps or cements. The hydraulic system operates under extremely high pressure. Such repairs will fail suddenly and create a hazardous and unsafe condition.

4. Wear proper hand and eye protection when searching for a high pressure hydraulic leak. Use a piece of wood or cardboard as a backstop instead of hands to isolate and identify a leak.

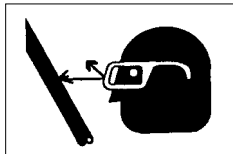

5. If injured by a concentrated high-pressure stream of hydraulic fluid, seek medical attention immediately. Serious infection or toxic reaction can develop from hydraulic fluid piercing the skin surface.
6. Relieve pressure on hydraulic system before maintaining or working on system.

2.9 STORAGE SAFETY

1. Store the unit in an area away from human activity.
2. Do not allow children to play on or around the stored machine.
3. Store the unit in a dry, level area. Support the frame with planks if required.

2.10 TRANSPORT SAFETY

1. Comply with state and local laws governing safety and transporting of machinery on public roads.
2. Check that all the lights, reflectors and other lighting requirements are installed and in good working condition.
3. Do not exceed a safe travel speed. Slow down for rough terrain and cornering.
4. Fold up and secure feed hopper intake before moving or transporting.
5. Be sure the trailer is hitched positively to the towing vehicle and a retainer is used through the hitch jaws. Always attach a safety chain between the hitch and the towing vehicle.
6. Do not drink and drive.
7. Be a safe and courteous driver. Always yield to oncoming traffic in all situations, including narrow bridges, intersections, etc. Watch for traffic when operating near or crossing roadways.
8. Never allow riders on the machine.

2.11 GAS MOTOR SAFETY

BEFORE STARTING ENGINE, READ AND UNDERSTAND THE OPERATING AND MAINTENANCE INSTRUCTIONS THAT CAME WITH YOUR ENGINE.

WARNING: DO NOT

1. DO NOT run engine in an enclosed area. Exhaust gases contain carbon monoxide, an odourless and deadly poison.
2. DO NOT place hands or feet near moving or rotating parts.
3. DO NOT store, spill, or use gasoline near an open flame, or devices such as a stove, furnace, or water heater which use a pilot light or devices which can create a spark.
4. DO NOT refuel indoors where area is not well ventilated. Outdoor refuelling is preferred.
5. DO NOT fill fuel chipper while engine is running. Allow engine to cool for 5 minutes before refueling. Store fuel in approved safety containers.
6. DO NOT remove fuel tank cap while engine is running.
7. DO NOT operate engine if gasoline is spilled. Move machine away from the spill and avoid creating any ignition until gasoline has evaporated.
8. DO NOT smoke while filling fuel tank.
9. DO NOT choke carburetor to stop engine. Whenever possible, gradually reduce engine speed before stopping.
10. DO NOT run engine above rated speeds. This may result in injury.
11. DO NOT tamper with governor springs, governor links or other parts which may increase the governed speed.
12. DO NOT tamper with the engine speed selected by the original equipment manufacturer.
13. DO NOT check for spark with spark plug or spark plug wire removed.
14. DO NOT crank engine with spark plug removed. If engine is flooded, place throttle in "FAST" position and crank until engine starts.
15. DO NOT strike flywheel with a hard object or metal tool as this may cause flywheel to shatter in operation. Use proper tools to service engine.
16. DO NOT operate engine without a muffler. Inspect periodically and replace, if necessary. If engine is equipped with a muffler deflector, inspect periodically and replace, if necessary with correct deflector.
17. DO NOT operate engine with an accumulation of grass, leaves, dirt or other combustible materials in the muffler area.
18. DO NOT use this engine on any forest covered, brush covered, or grass covered unimproved land unless a spark arrester is installed on the muffler. The arrester must be maintained in effective working order by the operator. In the state of California the above is required by law (Section 4442 of the California Public Resources Code). Other states may have similar laws. Federal laws apply on federal land.
19. DO NOT touch hot muffler, cylinder or fins because contact may cause burns.
20. DO NOT run engine with air cleaner or air cleaner cover removed.

WARNING: DO

1. ALWAYS DO remove the wire from the spark plug when servicing the engine or equipment TO PREVENT ACCIDENTAL STARTING. Disconnect the negative wire from the battery terminal if equipped with a 12 volt starting system.
2. DO keep cylinder fins and governor parts free of grass and other debris which can affect engine speed.
3. DO examine muffler periodically to be sure it is functioning effectively. A worn or leaking muffler should be repaired or replaced as necessary.
4. DO use fresh gasoline. Stale fuel can gum carburetor and cause leakage.
5. DO check fuel lines and fittings frequently for cracks or leaks. Replace if necessary.

2.12 REFUELING SAFETY

1. Handle fuel with care. It is highly flammable.
2. Allow engine to cool for 5 minutes before refueling. Clean up spilled fuel before restarting engine.
3. Do not refuel the machine while smoking or when near open flame or sparks.
4. Fill fuel tank outdoors.
5. Prevent fires by keeping machine clean of accumulated trash, grease and debris.



2.13 TIRE SAFETY

1. Failure to follow proper procedures when mounting a tire on a wheel or rim can produce an explosion which may result in serious injury or death.
2. Do not attempt to mount a tire unless you have the proper equipment and experience to do the job.
3. Have a qualified tire dealer or repair service perform required tire maintenance.
4. When replacing worn tires, make sure they meet the original tire specifications. Never undersize.

2.14 BATTERY SAFETY

1. Keep all sparks and flames away from batteries, as gas given off by electrolyte is explosive.
2. Avoid contact with battery electrolyte: wash off an spilled electrolyte immediately.
3. Wear safety glasses when working near batteries.
4. Do not tip batteries more than 45°, to avoid electrolyte loss.
5. To avoid injury from spark or short circuit, disconnect battery ground cable before servicing any part of the electrical system.

3 SAFETY SIGN LOCATIONS

The types of safety signs and locations on the equipment are shown in the illustrations that follow. Good safety requires that you familiarize yourself with the various safety signs, the type of warning and the area, or particular function related to that area, that requires your SAFETY AWARENESS.

- Think SAFETY! Work SAFELY!



A

CAUTION

- Read and understand operator's manual before starting. Review safety instructions annually.
- Turn machine off, stop and disable engine, remove ignition key and place in your pocket, set park brake and wait for all moving parts to stop before adjusting, servicing, maintaining, repairing or unplugging.
- Keep the working area clean and free of debris to prevent slipping or tripping. Operate only on level ground.
- Close and secure rotor cover before operating.
- Close and secure all guards, deflectors and shields before starting and operating.
- Keep hydraulic lines and fittings tight, in good condition and free of leaks.
- Keep hands, feet, hair and clothing away from moving parts. Never wear loose clothing around machinery.
- Keep driveline universal joint angles equal and small as possible.
- Do not point discharge at people, animals or buildings. Rotor can expel wood chips fast enough to cause injury.
- Do not allow children, animals or unauthorized people into working area.
- Do not run machine inside a closed building to prevent asphyxiation from engine exhaust.
- Use care when feeding material into chipper. Do not send metal, bottles, cans, rocks, glass or other foreign material into wood chipper. If foreign material enters chipper, stop the machine, turn engine off and place ignition key in your pocket and wait for all moving parts to stop before removing material and/or unplugging. Inspect machine for damaged or loose parts before returning to work.
- Always wear P.P.E. (Personal Protective Equipment) such as safety goggles and heavy gloves whenever operating machine.
- Do not place hands or any body parts into feed hopper during operation.
- Do not move or transport chipper when the rotor is turning.
- Do not exceed a safe travel speed when transporting. Cross safety chain under hitch on trailer model when attaching to a truck.

Z94006

B

DANGER

ROTATING CUTTING BLADES

Keep hands and feet out of inlet and discharge openings while machine is operating to avoid serious personal injury. Stop engine, remove spark plug wire and allow machine to come to a complete stop before clearing obstructions or making adjustments.

Z94007

REMEMBER - If safety signs have been damaged, removed, become illegible or parts replaced without safety signs, new signs must be applied. New safety signs are available from your authorized dealer.

The types of safety signs and locations on the equipment are shown in the illustrations that follow. Good safety requires that you familiarize yourself with the various safety signs, the type of warning and the area, or particular function related to that area, that requires your SAFETY AWARENESS.

- Think SAFETY! Work SAFELY!



C

⚠
WARNING



**ROTATING PART HAZARD
KEEP AWAY**

To prevent serious injury or death from rotating parts:

- Turn machine off, stop and disable engine, remove ignition key and place in your pocket, set park brake and wait for all moving parts to stop before adjusting, servicing, maintaining, repairing or unplugging.
- Close and secure guard before operating.
- Keep hands, feet, hair and clothing away from moving parts.

Z94012

D

⚠
DANGER



**FIRE HAZARD
NO SMOKING**

To prevent serious injury or death from fire:

- Do not smoke when refueling.
- Keep sparks, flames and hot material away from flammable substances.
- Stop engine five minutes before refueling.

Z94065

REMEMBER - If safety signs have been damaged, removed, become illegible or parts replaced without safety signs, new signs must be applied. New safety signs are available from your authorized dealer.

The types of safety signs and locations on the equipment are shown in the illustrations that follow. Good safety requires that you familiarize yourself with the various safety signs, the type of warning and the area, or particular function related to that area, that requires your SAFETY AWARENESS.



REMEMBER - If safety signs have been damaged, removed, become illegible or parts replaced without safety signs, new signs must be applied. New safety signs are available from your authorized dealer.

The types of safety signs and locations on the equipment are shown in the illustrations that follow. Good safety requires that you familiarize yourself with the various safety signs, the type of warning and the area, or particular function related to that area, that requires your SAFETY AWARENESS.

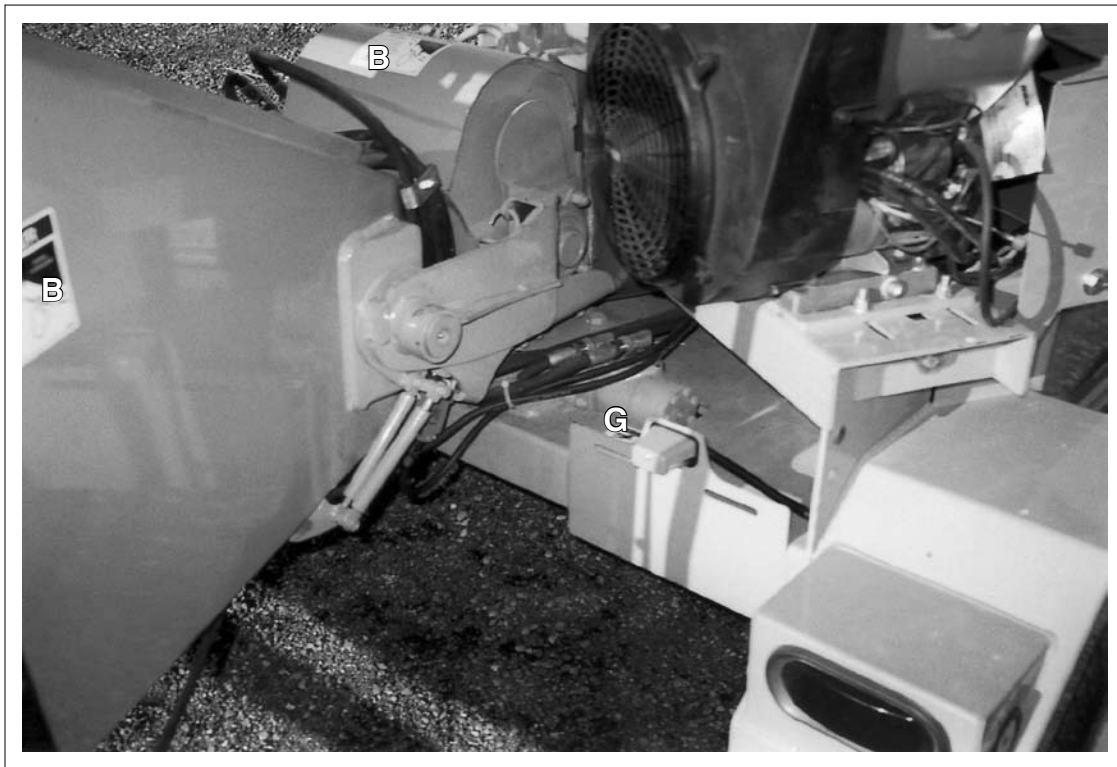

E

! DANGER



THROWN OBJECT HAZARD

To prevent serious injury or death from thrown objects:

- Turn machine off, stop and disable engine, set park brake, remove ignition key and place in your pocket and wait for all moving parts to stop before servicing, adjusting, repairing or unplugging.
- Do not direct discharge duct towards people, animals or property. Always wear appropriate safety gear. Keep hands and feet out of discharge openings.
- Keep others away.

Z94008

F

! DANGER



MISSING GUARD HAZARD

- Close and secure all guards and shields before operating.
- Do not operate without guards and shields.

Z94013

G

! WARNING



HIGH PRESSURE FLUID HAZARD

To prevent serious injury or death from high-pressure fluid:

- Relieve pressure on system before repairing or adjusting.
- Wear proper hand and eye protection when searching for leaks. Use wood or cardboard instead of hands.
- Keep all components in good repair.

Z94005

REMEMBER - If safety signs have been damaged, removed, become illegible or parts replaced without safety signs, new signs must be applied. New safety signs are available from your authorized dealer.

4 OPERATION



OPERATING SAFETY

- Please remember it is important that you read the operator's manual and heed the safety signs on the Commercial Trailer Wood Chipper. They are there for your safety, as well as the safety of others. The safe use of this machine is strictly up to you, the operator.
- Personal protection equipment including hearing protection, hard hat, safety glasses, safety shoes, and gloves are recommended during assembly, installation, operation, adjustment, maintaining, repairing, or plugging. Do not allow long hair, loose-fitting clothing, or jewellery to be around moving parts.
- Turn machine off, stop and disable engine, remove ignition key and place in your pocket, set park brake and wait for all moving parts to stop before servicing, adjusting, repairing or unplugging.
- Do not run machine inside a closed building to prevent asphyxiation from engine exhaust.
- Use care when feeding material into chipper. Do not send metal, bottles, cans, rocks, glass or other foreign material into wood chipper. If foreign material enters chipper, stop machine, turn engine off and place ignition key in your pocket and wait for all moving parts to stop before removing material and/or unplugging. Inspect machine for damaged or loose parts before resuming work.
- Never use alcoholic beverages or drugs which can hinder alertness or coordination while operating this equipment. Consult your doctor about operating this machine while taking prescription medications.
- Do not allow riders on this machine at any time. There is no safe place for any riders.
- Never allow children or unauthorized people to operate or be around this machine.
- Do not reach into rotor or feed hopper openings when the engine is running. Install and secure access covers before starting engine.
- Do not move or transport chipper when the rotor is turning.
- Do not exceed a safe travel speed when transporting. Cross safety chain under hitch on trailer model when attaching to truck.
- Keep hydraulic lines and fittings tight, in good condition and free of leaks.
- Keep the working area clean and free of debris to prevent tripping. Operate only on level ground.
- Do not point discharge at people, animals or buildings. Rotor can expel wood chips fast enough to cause injury.

4.1 TO THE NEW OPERATOR OR OWNER

The Wallenstein Commercial Trailer Wood Chippers are designed to chip or chop scrap lumber, small trees, brush, limbs and other wood debris. The chipped material is fine enough to be composted or used in a variety of ways.

It is the responsibility of the owner or operator to read this manual and to train all other operators before they start working with the machine. Follow all safety instructions exactly. Safety is everyone's business. By following recommended procedures, a safe working environment is provided for the operator, bystanders and the area around the worksite. Untrained operators are not qualified to use the machine.

Follow all safety instructions exactly. Safety is everyone's business. By following recommended procedures, a safe working environment is provided for the operator, bystanders and the area around the worksite. Untrained operators are not qualified to operate the machine.

Many features incorporated into this machine are the result of suggestions made by customers like you. Read this manual carefully to learn how to use the chipper safely and how to set it to provide maximum field efficiency. By following the using instructions in conjunction with a good maintenance program, your Commercial Trailer Wood Chipper will provide many years of trouble-free service.

4.2 MACHINE COMPONENTS

The Wallenstein Commercial Trailer Wood Chipper is a rotor with blades for chipping wood. A feed hopper moves the wood material into the rotor. Hydraulically driven rollers in the throat of the feed hopper pull and direct the wood material into the rotor. A hinged intake panel with a "panic" shut-down bar is positioned over the entrance to the hopper. A "U" shaped control located at the entrance to the hopper controls the action of the feed rollers.

Each rotor is designed with 2 blades, paddles and a twig-breaker to generate the small pieces of wood. A stationary knife at the rear of the rotor housing is placed by the moving knives to shear, chip or chop the material.

An engine is mounted on the frame to drive the rotor. Power is transmitted through a centrifugal clutch on the engine output shaft and through a V belt drive system. A hydraulic pump is mounted on the forward end of the rotor shaft to provide hydraulic capability to the machine.

A controller is used to monitor and measure the rotor speed and to control the roller speed. As the rotor speed decreases, the feed roller speed is decreased to prevent overloading the rotor. The display on the controller can show the engine oil life, machine hours or rotor RPM.

- A Feed Hopper
- B Discharge Hood
- C Rotor Housing
- D Rotor Blade
- E Stationary Blade
- F Twig Breaker
- G Hood Deflector
- H Engine
- J Centrifugal Clutch
- K Belt Drive
- L Gas Tank
- M Rotor
- N Paddle
- O Feed Rollers
- P Hydraulic Pump
- Q Hydraulic Motor
- R Speed Sensor
- S Hydraulic Tank
- T Feed Table
- U Panic Bar
- V Feed Control

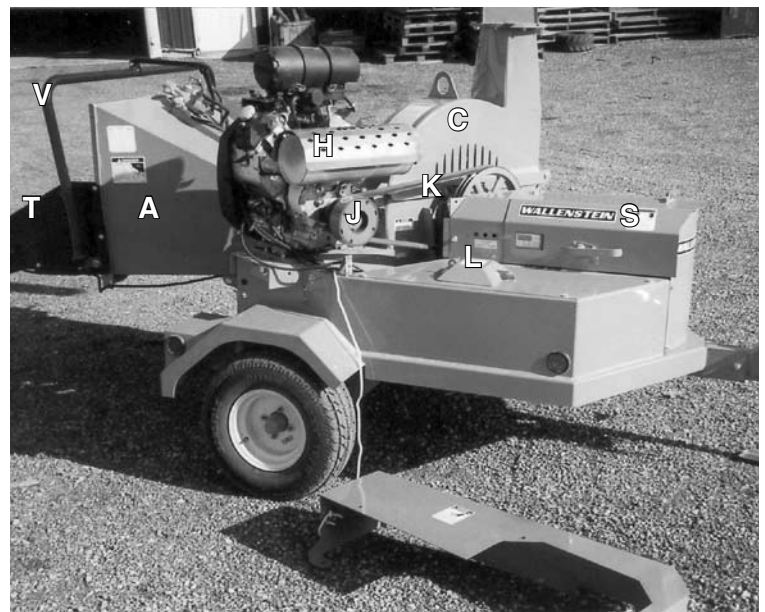
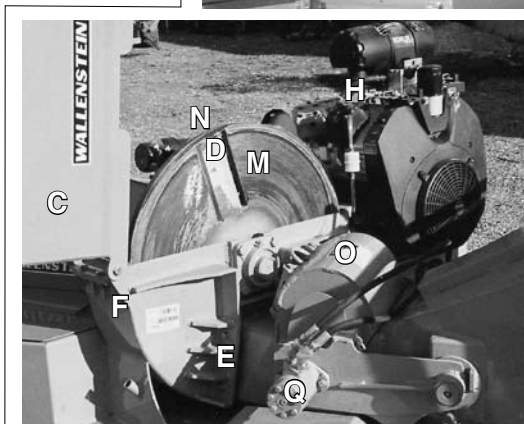
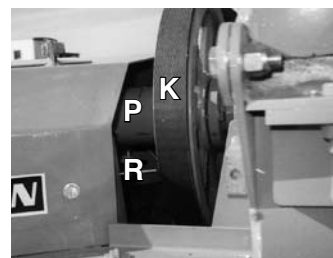
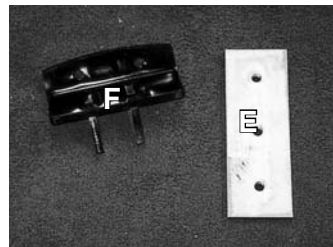
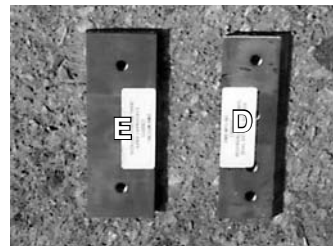

Fig. 1 PRINCIPLE COMPONENTS

4.3 MACHINE BREAK-IN

Although there are no operational restrictions on the Commercial Trailer Wood Chipper when used for the first time, it is recommended that the following mechanical items be checked:

A. After operating for 1 hour:

1. Check alignment of pulleys. Align as required.
2. Check belt tension. Adjust as required.
3. Torque all fasteners and hardware.
4. Check condition of electrical and hydraulic components. Keep all components in good condition.
5. Check condition of rotor bearings.
6. Check the condition and clearance of the twig-breaker, rotor and stationary blades. Adjust or replace as required.
7. Check all fluid levels. Add as required.
8. Check for entangled material. Remove all entangled material before resuming work.
9. Check tire pressure. Inflate as required.

B. After operating for 10 hours:

1. Repeat steps 1 through 9 listed above. (Section A)
2. Change engine oil.
3. Go to the normal servicing and maintenance schedule as defined in the Maintenance Section.

4.4 PRE-OPERATION CHECKLIST

Efficient and safe operation of the Wallenstein Commercial Trailer Wood Chipper requires that each operator reads and understands the using procedures and all related safety precautions outlined in this section. A pre-operation checklist is provided for the operator. It is important for both the personal safety and maintaining good mechanical condition that this checklist is followed.

Before operating Wood Chipper and each time thereafter, the following areas should be checked off:

1. Lubricate the machine per the schedule outline in the Maintenance Section.
2. Check the tension and alignment of the belts. Adjust tension and align as required.
3. Check the rotor, blades and twig-breaker. Remove any twine, wire or other material that has become entangled.
4. Check the condition and clearance of the twig-breaker, rotor and stationary blades. Adjust or replace as required.
5. Check condition of electrical and hydraulic components. Keep all components in good condition.
6. Check engine fluid levels. Top up as required.
7. Check that all bearings turn freely. Replace any that are rough or seized.
8. Make sure that all guards and shields are in place, secured and functioning as designed.
9. Check the condition of the feed rollers in the feed hopper. They must be in good condition to move the material evenly into the rotor.

4.5 CONTROLS

Before starting to work, all operators should familiarize themselves with the location and function of controls.

1. Gas Engine:

Read the engine manufacturers operator's manual before starting for more detailed instructions.

a. Ignition Switch:

This key operated switch controls the electric power to the engine.

OFF Turn key fully counterclockwise to stop the electrical system power and turn the engine off.

RUN Turn clockwise on detent to the run position. This is the position where the engine will continue to run.

START Turn fully clockwise to the last spring-loaded detent position to engage the starter solenoid and start the engine. Release the key when the engine starts and it will return to the RUN position.

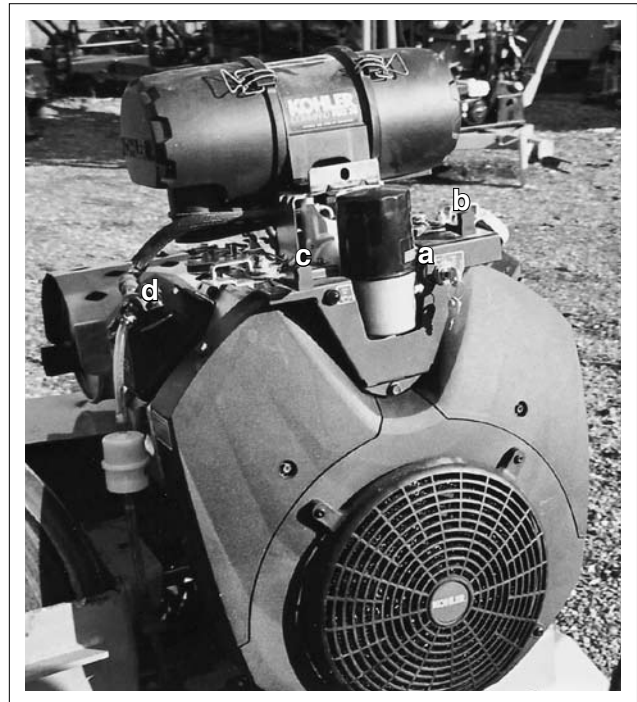

Fig. 2 ENGINE

b. Choke:

This sliding lever controls the position of the choke. Slide the lever to the right to open the choke and to the left to close it.

c. Throttle:

This sliding lever controls the position of the throttle. Slide the lever to the right to decrease engine RPM and to the left to increase engine RPM.

d. Fuel Shut-Off Valve:

This valve controls the flow of fuel to the engine. Turn the valve at right angles to the fuel line to turn the fuel off and parallel to turn the fuel on.

2. **Hydraulic Feed Control Lever:**
This lever is positioned to extend around the feed hopper and provides access from all sides. Pull the control all the way out to engage the feeding system. Push in slightly to the first detent to stop the feeding system. Push the control all the way in to reverse the feeding system.



Feeding



Neutral/Stop



Reversing

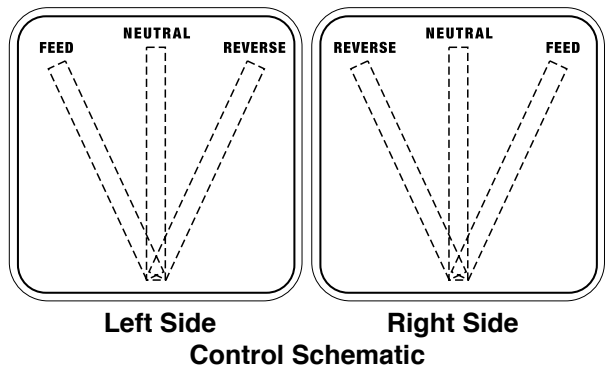

Fig. 3 HYDRAULIC FEED CONTROL LEVER

3. **Deflector Position:**
Each discharge hood is equipped with a deflector on the end to place the chips exactly where desired. The deflector support bracket is designed with slots to position the deflector where desired. Place in the appropriate slot.

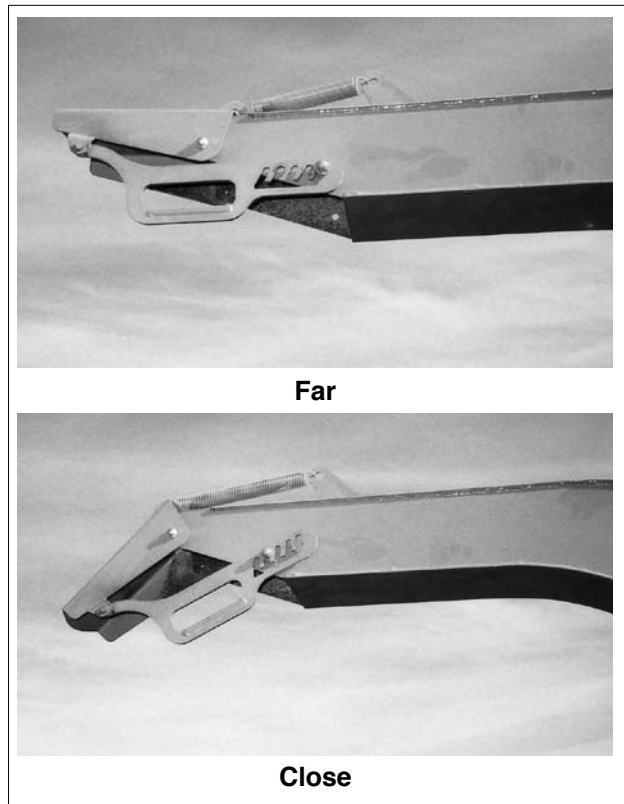

Fig. 4 DEFLECTOR POSITION

4. **Control Panel:**

- a. **Controller:**
Review the controller operator's manual provided with the machine for detailed operating instructions. This panel displays the parameters monitored by the controller. Depress the title works on the front of the panel to select the display for the engine oil life, machine hours and rotor RPM.
- b. **Panic Bar Activated:**
This light is illuminated when the "Panic Bar" is activated and goes out when it is reset.
- c. **Roller Hood Closed:**
This light is illuminated when the roller hood is closed and goes out when the hood is opened.
- d. **Rotor Hood Closed:**
This light is illuminated when the rotor hood is closed and goes out when the hood is opened.

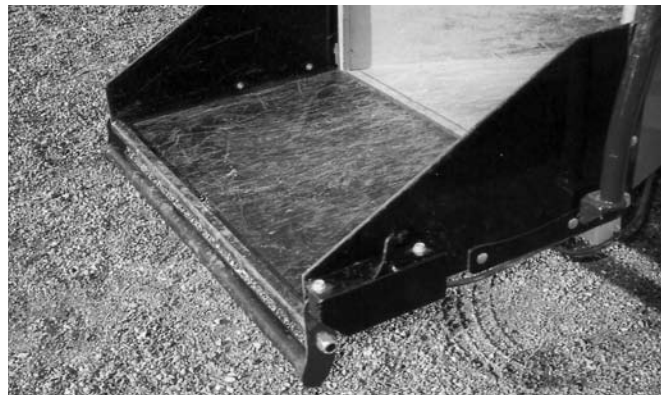

Fig. 5 CONTROLLER

5. **Panic Bar:**

The feed hopper entrance is designed with a feed table that is equipped with a "Panic Bar" which is designed to stop the feed rollers should an operator be pulled into the feed hopper.

Push the latch toward the roller to reset the "Panic Bar". When the "Panic Bar" is activated, the light on the front of the panel will illuminate.



Tripped



Normal Position

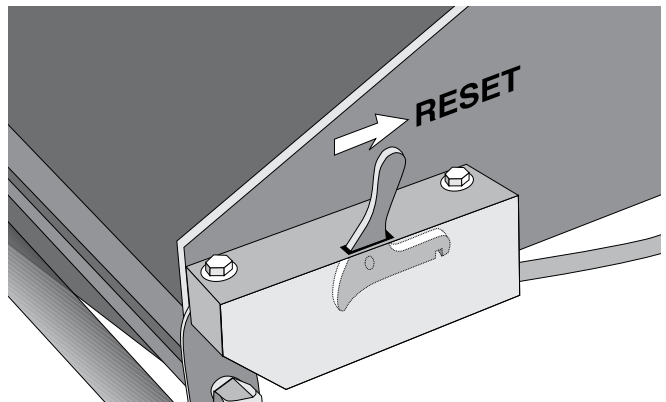

Trigger



Panel Light

Fig. 6 PANIC BAR

4.6 ATTACHING/UNHOOKING

The Commercial Trailer Wood Chipper should always be located on a level, dry area that is free of debris and other foreign objects. When attaching the machine to a power unit, follow this procedure:

1. Make sure that all bystanders, especially small children, are clear of the working area.
2. Make sure there is enough room and clearance to safely back up to the machine.
3. Slowly back the tow vehicle until the jaws on the hitch and ball are aligned.
4. Lift the hitch and place the jaws over the ball on the hitch.
5. Flip the latch to lock the jaws around the ball.
6. Install the retainer to secure the jaws.
7. Attach the safety chain securely to the truck frame to prevent unexpected separation. Cross the chains when attaching.

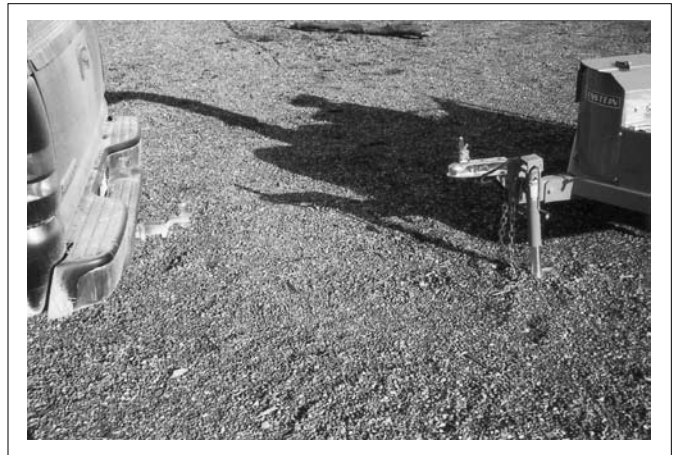

Fig. 7 ALIGNED



Fig. 8 JAWS



Fig. 9 SAFETY CHAIN

4.6 ATTACHING/UNHOOKING (CONT)

8. Connect the wiring harness for the lights.
9. Route the harness and cables across the hitch to prevent snagging. Be sure to provide slack for turning.

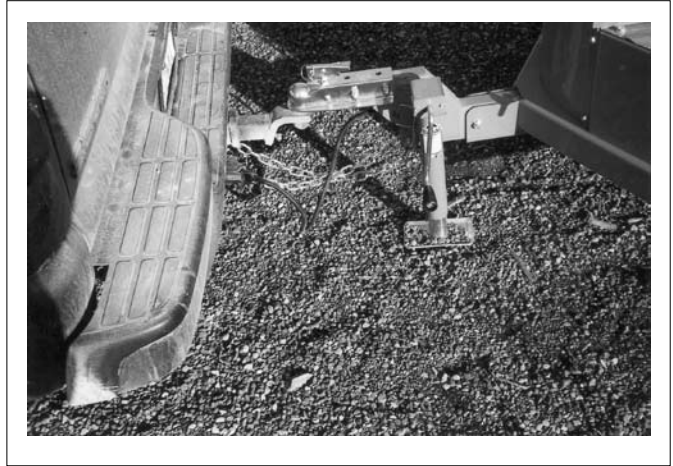

Fig. 10 STAND/WIRING HARNESS

10. Pull out the lock pin and pull up to place jack frame in its storage place. Install anchor pin.
11. Reverse the above procedure when unhooking.



Fig. 11 RETAINER

4.7 FIELD OPERATION



OPERATING SAFETY

- Please remember it is important that you read the operator's manual and heed the safety signs on the Commercial Trailer Wood Chipper. They are there for your safety, as well as the safety of others. The safe use of this machine is strictly up to you, the operator.
- Personal protection equipment including hearing protection, hard hat, safety glasses, safety shoes, and gloves are recommended during assembly, installation, operation, adjustment, maintaining, repairing, or plugging. Do not allow long hair, loose-fitting clothing, or jewellery to be around moving parts.
- Turn machine off, stop and disable engine, remove ignition key and place in your pocket, set park brake and wait for all moving parts to stop before servicing, adjusting, repairing or unplugging.
- Do not run machine inside a closed building to prevent asphyxiation from engine exhaust.
- Use care when feeding material into chipper. Do not send metal, bottles, cans, rocks, glass or other foreign material into wood chipper. If foreign material enters chipper, stop machine, turn engine off and place ignition key in your pocket and wait for all moving parts to stop before removing material and/or unplugging. Inspect machine for damaged or loose parts before resuming work.
- Never use alcoholic beverages or drugs which can hinder alertness or coordination while operating this equipment. Consult your doctor about operating this machine while taking prescription medications.
- Do not allow riders on this machine at any time. There is no safe place for any riders.
- Never allow children or unauthorized people to operate or be around this machine.
- Do not reach into rotor or feed hopper openings when the engine is running. Install and secure access covers before starting engine.
- Do not move or transport chipper when the rotor is turning.
- Do not exceed a safe travel speed when transporting. Cross safety chain under hitch on trailer model when attaching to truck.
- Keep hydraulic lines and fittings tight, in good condition and free of leaks.
- Keep the working area clean and free of debris to prevent tripping. Operate only on level ground.
- Do not point discharge at people, animals or buildings. Rotor can expel wood chips fast enough to cause injury.

Although the Commercial Trailer Wood Chipper is easy to use, each operator should review this section to familiarize himself with the detailed safety and operating procedures. When using this machine, follow this procedure:

1. Clear the area of bystanders, especially small children.
2. Review and follow the Pre-Operation Checklist (see Section 4.4).
3. Attach the machine to the tow vehicle (see Section 4.6).
4. Use the latch in the center of the feed table to move the feed hopper intake gate down into its working configuration.



Up



Down

Fig. 12 FEED HOPPER

5. Starting the Machine:

- a. Turn machine off, stop and disable engine, remove ignition key and place in your pocket, set park brake and wait for all moving parts to stop before servicing, adjusting, repairing or unplugging.
- b. Close the choke if the engine is cold.
- c. Move the throttle to its 1/4 throttle position.
- d. Open the fuel supply valve.
- e. Turn the ignition key on the machine to start the engine.
- f. Run the engine for a few minutes to allow it to warm.
- g. Gradually open the choke.
- h. Turn the discharge head to its desired position.
- i. Slowly increase the engine speed to engage the centrifugal clutch.
- j. Increase throttle setting to maximum speed for operation.
- k. Place material into hopper.
- l. Pull on the feeding lever to start the rollers and start to chip.

6. Stopping:

- a. Stop feeding material into the hopper.
- b. Place feed lever in neutral.
- c. Slow engine RPM.
- d. Stop engine using ignition switch.

7. Emergency Stopping:

Stop machine engine if an emergency occurs. Correct emergency situation before starting engine and resuming work.



Machine



Working



Stopping

Fig. 13 STARTING/STOPPING

8. Feeding:

- a. Slowly slide the wooden material into the feed hopper and move it into the roller.
- b. Pull on the feed lever to engage the feed rollers to move the material into the rotor.
- c. Do not push the material - use the feed rollers.
- d. Once the rollers are engaged, the automatic feed system will move the material into the rotor. The automatic feeding feature will slow the roller when the rotor speed slows and speeds up when the rotor speed recovers. If the rotor speed decreases significantly, the rollers will stop and then resume when the rotor speed increases again.
- e. Do not reach into the feed hopper and contact the roller to be sure not to be pulled into the machine.
- f. Use a stick or branch to push any piece of material into the rollers or rotor that does not move on its own and stops in the hopper. Do not take a chance with getting your hand caught in the feed rollers.
- g. Always wear personal protective equipment (PPE) whenever operating the machine. This includes but is not limited to protective shoes with slip resistant soles, protective goggles or face shield, heavy gloves, hearing protection and protective clothing.
- h. Do not place metal, bottles, cans, rocks, glass or other solid material into the wood chipper. If something like this gets into the machine, stop the machine immediately for a detailed inspection. Stop engine, remove ignition key and place in your pocket and wait for all moving parts to stop before inspecting or unplugging. Inspect machine for damaged or loosened parts before resuming work.



Rollers



Chipping

Fig. 14 OPERATING

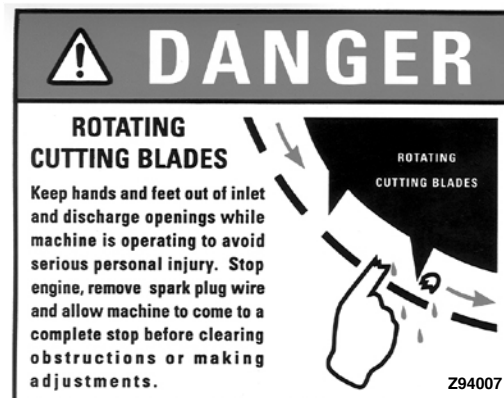

9. Blades:

There are 2 types of blades used on the Wood Chipper. They work together to cut, shear and shred the wood as it moves through the machine.

a. Rotor blades:

The rotor is equipped with 2 blades placed at 180° to each other to keep the rotor in balance. If one needs to be changed, both should be changed.

b. Stationary blade:

Each machine is equipped with a stationary blade that acts as a stop for the moving rotor blades.



a. Rotor

b. Stationary

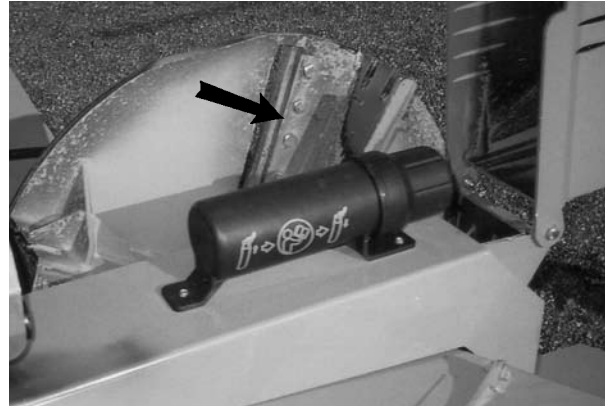

Rotor

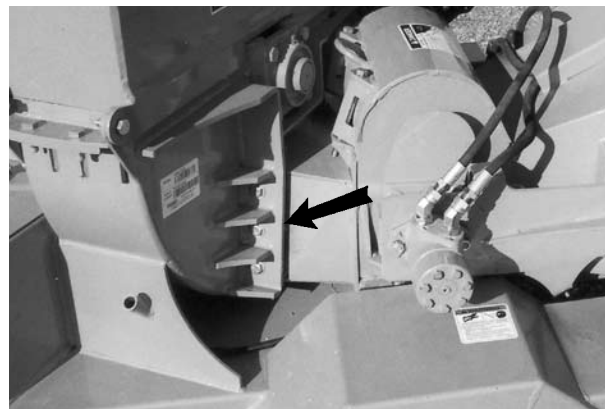

Stationary

Fig. 15 BLADES

10. Twig Breaker:

Each machine is equipped with a twig breaker to break up twigs or other long material as it moves through the rotor compartment. Open the rotor cover and check the condition of the breaker on a weekly basis. Also check for any entangled material when the rotor cover is opened. Remove this material prior to closing the cover and resuming work.

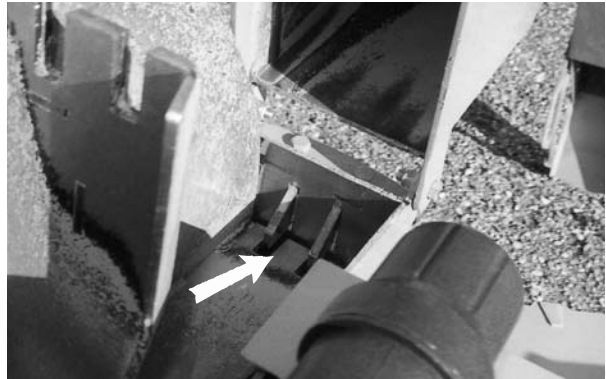

Single

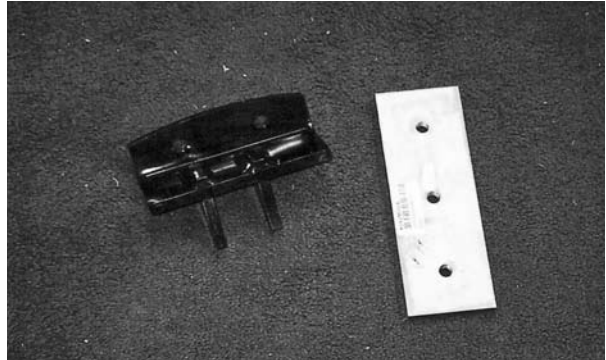

Removed



Mounting

Fig. 16 TWIG BREAKER

11. Belt Drive System:

A V belt drive system transmits power from the engine to the rotor.

A centrifugal clutch on the engine output shaft engages when the RPM reaches 1400 RPM. Always set the throttle to the 1/4 position when starting to prevent the clutch engaging and the rotor turning when starting.

Loosen the engine mounting bolts and slide the engine to the required position to set the belt tension. Be sure to check that the pulleys are in alignment whenever the engine is moved.

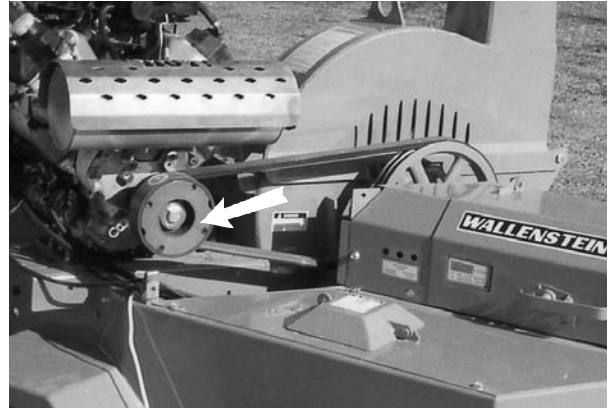

Clutch

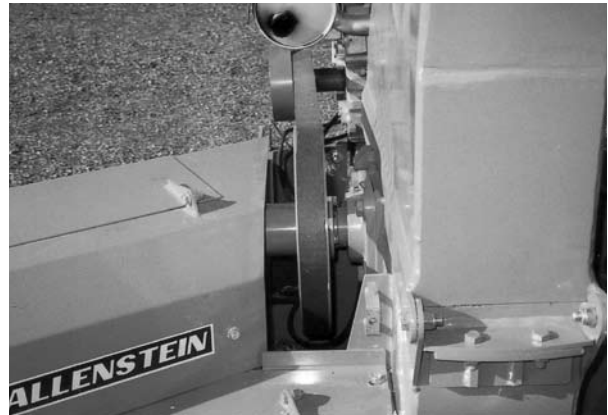

Alignment

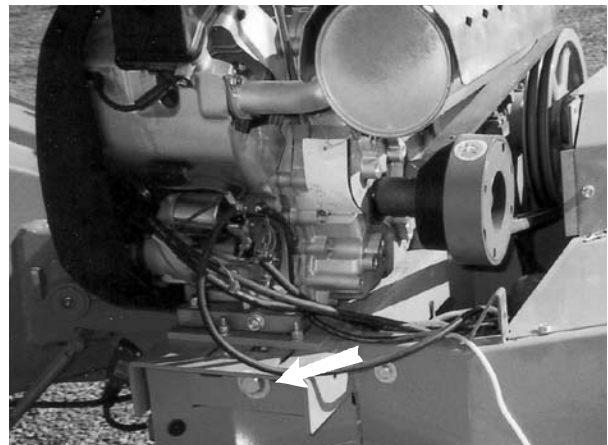

Engine Adjusting Bolts

Fig. 17 BELT DRIVE SYSTEM

12. Unplugging:

Although the machine is designed to handle a wide variety of material without any problem, occasionally it plugs. When the machine plugs, follow this procedure to unplug:

- a. Clear the area of bystanders, especially small children.
- b. Reverse the feed rollers to remove the material from the feed hopper. Be sure all the material is out and nothing is jammed or wedged between the rollers and the rotor. If this does not unplug the chipper or the engine is stopped, the plug must be removed by hand.
- c. Stop the engine, remove the ignition key and place it in your pocket and wait for all moving parts to stop before unplugging.
- d. Pull the material out of the discharge hood. Use a stick to poke loose any material jammed into the discharge hood. Do not allow anything to remain in this area.



e. Severe plug:

- Loosen the feed roller frame anchor nuts and raise the feed hopper. Remove material from inside the roller compartment.
 - Clean out the discharge area/rotor.
 - Open the rotor cover and clean out the housing. Be sure to turn the rotor by hand to be sure there is nothing jammed between the rotor and stationary blade.
 - Close, install and fold down all components opened to unplug. Tighten fasteners to their specified torque.
- f. Check that everyone is clear of machine before restarting engine.
 - g. Start the engine and resume working.

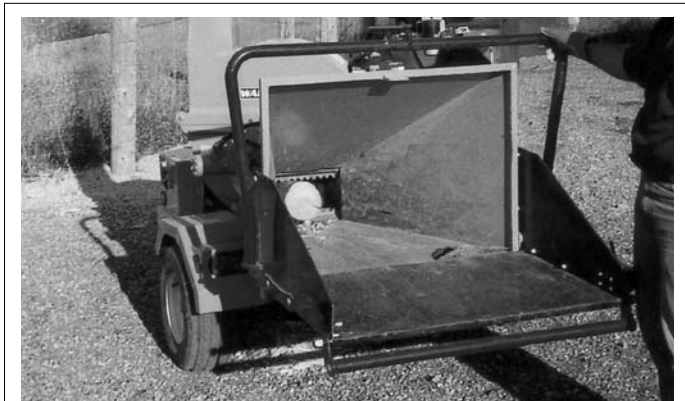

Feed Hopper - Input

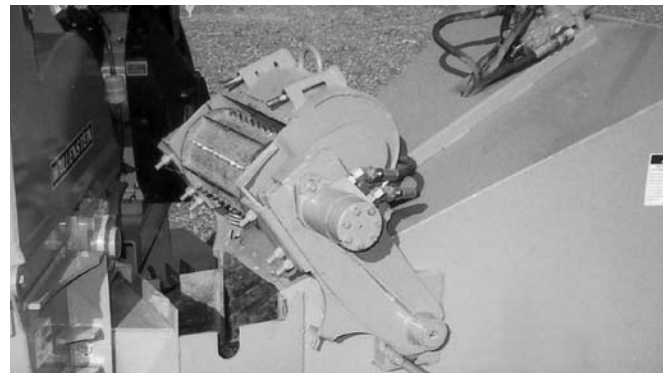

Feed Rollers



Discharge Hood



Rotor Cover

Fig. 18 SEVERE PLUG

13. Refuelling:

The fuel tank is located in the front frame and is accessed by lifting the cover over the cap. Use the fuel gauge on top of the tank when checking the level of fuel in the tank. Do not overfill. Watch the fuel gauge to prevent spilling. Do not smoke when refuelling.

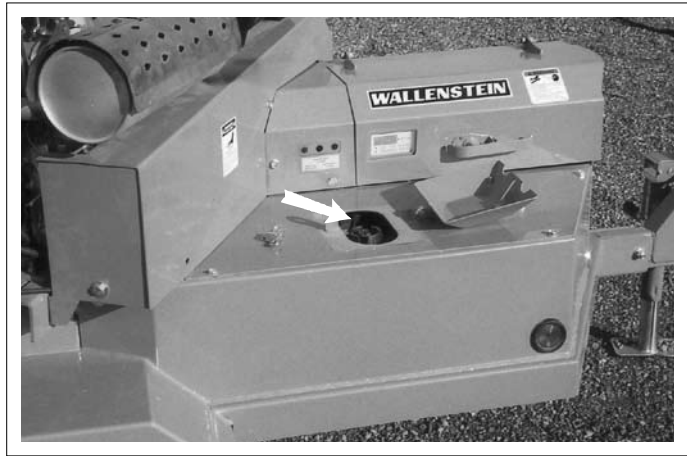

Fig. 19 FUEL TANK

14. Cleaning:

Clean the machine frequently to prevent a build-up of dust, chips and trash on the frame. A clean machine reduces the chance of rusting.



Fig. 20 CLEANING

15. Clearance:

It is recommended that the clearance between the rotor and stationary blades be set and maintained at 1/32 inch (0.8 mm) or obtain the best performance. Use the stationary blade mounting bolts to set the clearance as required. Slide a piece of 11 gauge material between the blades to check the clearance.

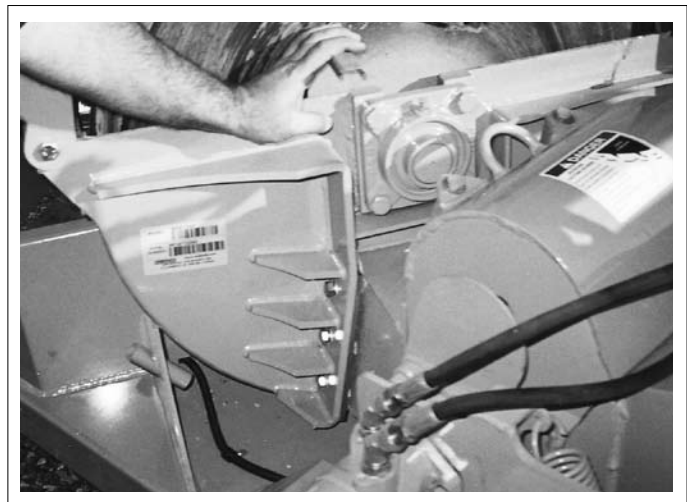

Fig. 21 CLEARANCE

16. Sharpening Blades:

The rotor and stationary blades need to be sharp for the chipper to perform as expected. It is recommended that the rotor blades be removed from the rotor when sharpening. Always sharpen the blades at a 45° angle to provide the best cutting effect as it meets the stationary blade. Be sure to tighten the blade mounting bolts to their specified torque when re-installing the blades to the rotor.

The stationary blade is designed with 4 sharp corners that can be utilized. When the corner facing the rotor blade rounds over, remove the blade and re-install with a different corner facing the rotor blade. Use the stationary blade to set the clearance to the rotor blade when re-installing. Be sure to tighten mounting bolts to their specified torque.

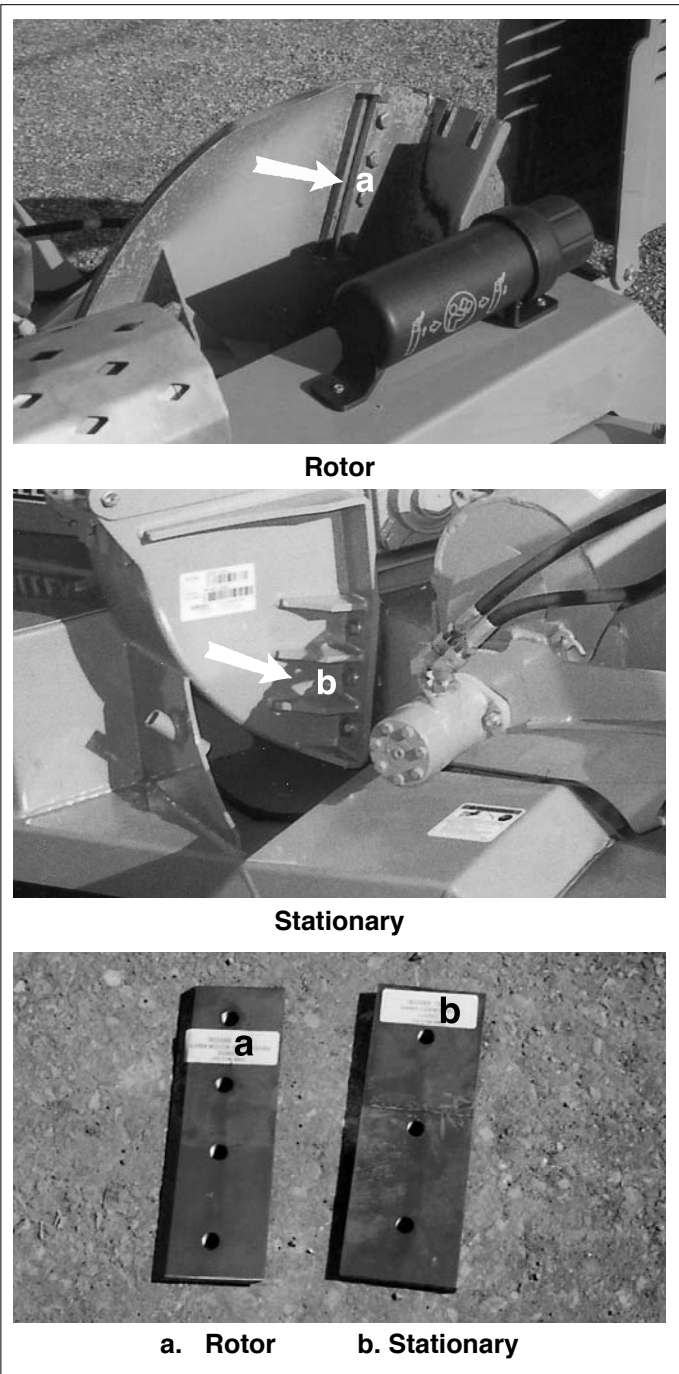
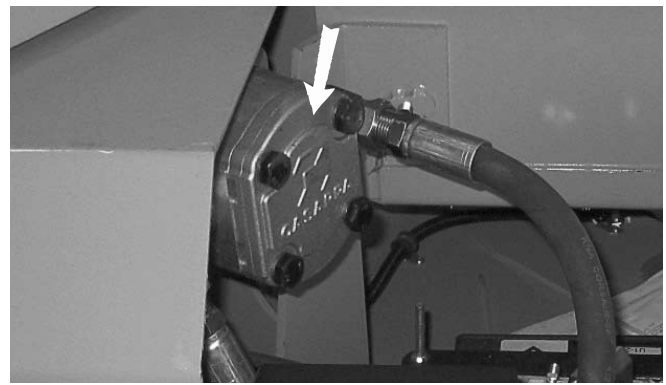

Fig. 22 BLADES

17. Hydraulic System:

The chipper is designed with a self-contained hydraulic system with a tank, pump, valves, motors and appropriate hoses. Pressurized oil is used to power the feed rollers. It also allows the feed roller drive system to be part of the material feeding system.

A hydraulic pump is mounted on the end of the driven end of the rotor shaft and is plumbed to the adjacent hydraulic tank. A sensor on the rotor shaft measures the rotor speed. The controller slows or stops the the feed rollers until the shaft speed increases to the required RPM. A valve in the circuit controls and meters the amount of oil flowing to each feed roller hydraulic motor.



Pump



Valve Attached



Sensor

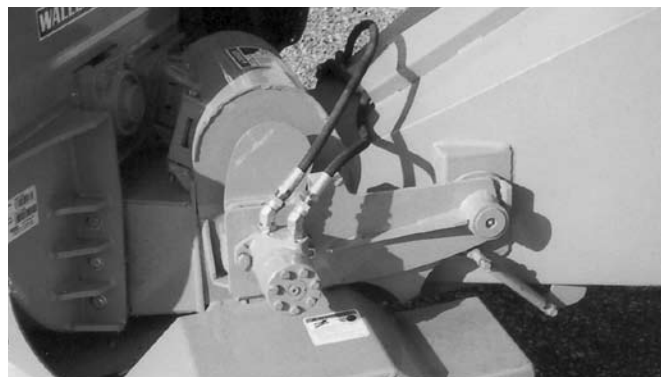

Roller Drive Motor

Fig. 23 HYDRAULIC SYSTEM

18. Electrical System:

The chipper is designed with an electrical system that includes a CPU (Central Processing Unit), display, speed sensor and electro-hydraulic valve. The CPU measures the rotor speed through the speed sensor and closes the valve when the rotor speed slows. It also increases the flow when the rotor speed recovers back to operating RPM.

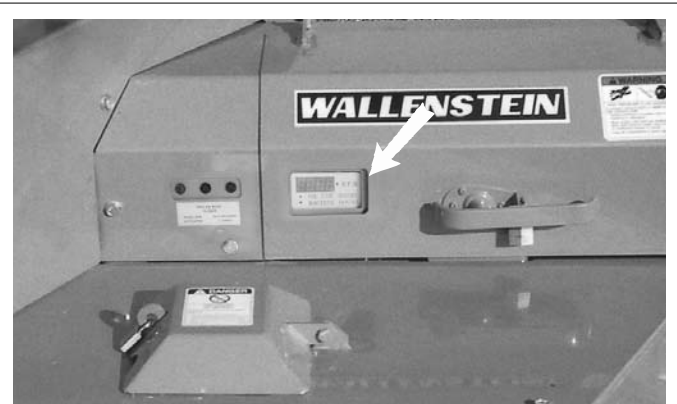

Display

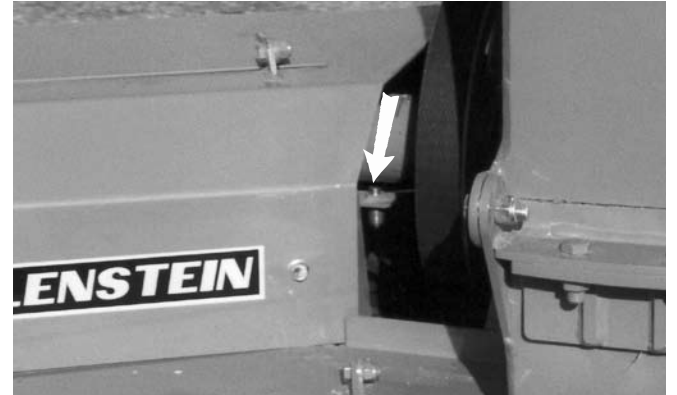

Sensor



Engine Sensor



Valve

Fig. 24 ELECTRICAL SYSTEM

19. **Panic Bar:**

The feed table is designed with a "Panic Bar" on the end of the feed hopper intake. It is designed to stop the feed rollers should an operator be pulled into the hopper.

The feed table is designed with a latch in the center of the frame. Release the latch when raising or lowering the gate.

Push on the "Panic Bar" to stop the feed rollers. Move the latch toward the roller to reset the "Panic Bar" and start the roller.

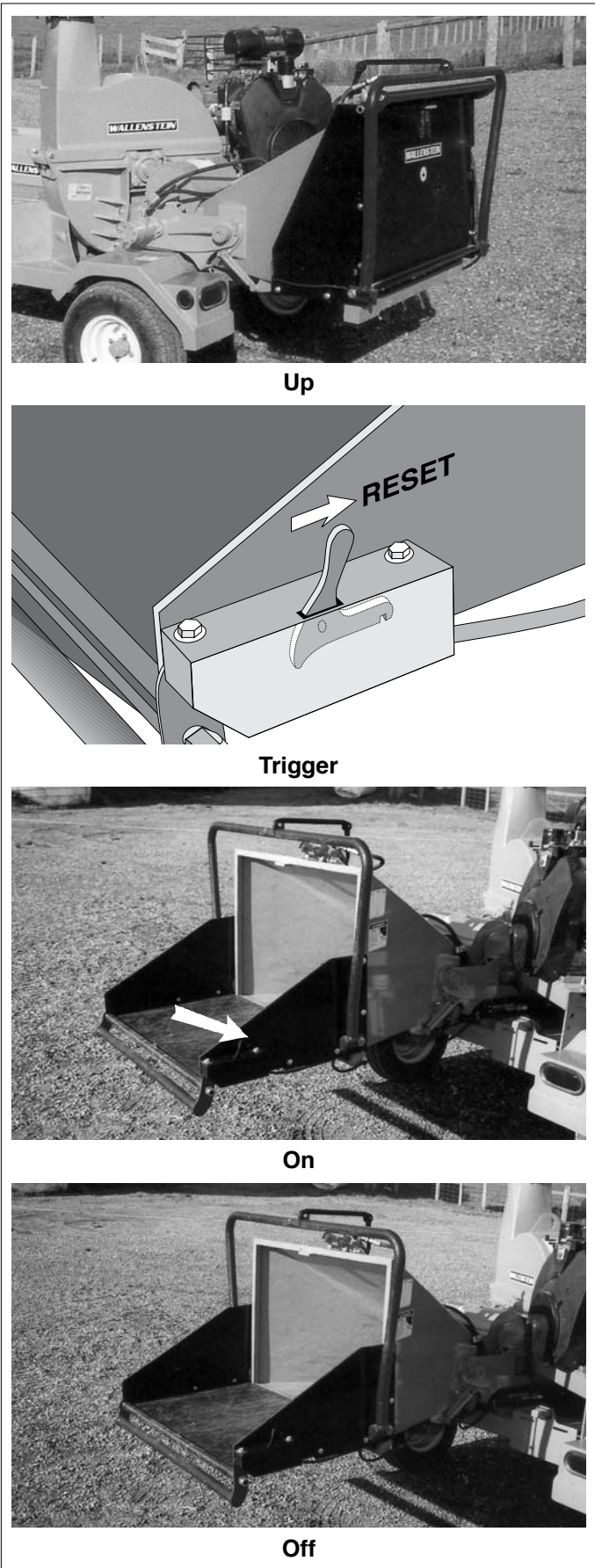

Fig. 25 PANIC BAR

20. Personal Protective Equipment (PPE):

Each person must wear appropriate personal protective equipment whenever operating the chipper or working in the vicinity. This equipment is designed to prevent injury to any personnel in the area. This list includes but is not limited to:

- Safety shoes with slip resistant soles.
- Safety goggles or face shield.
- Hearing protection.
- Heavy or leather gloves.



Fig. 26 PERSONAL PROTECTIVE EQUIPMENT

21. Operating Hints:

- Keep the working area clean and free of debris to prevent slipping or tripping. Operate only on level ground.
- Do not place hands or any body parts into the feed hopper during operation. Use the feed rollers to move material into the rotor rather than your hands.
- Do not point discharge at people, animals or buildings. Rotor can expel wood chips fast enough to cause injury.
- Use care when feeding material into the chipper. Do not send metal, bottles, cans, rocks, glass or other foreign material into the wood chipper. If foreign material enters chipper, stop machine, turn engine off and place ignition key in your pocket and wait for all moving parts to stop before removing material and/or unplugging. Inspect machine for damaged or loose parts before resuming work.



Fig. 27 POSITIONED

4.8 TRANSPORTING



TRANSPORT SAFETY

- Do not exceed a safe travel speed.
- Always follow and obey applicable highway rules and regulations.
- Be sure all lights and markers required by the traffic regulations are in place, clean and working.
- Always attach the safety chains between the machine and the pick-up. Cross the chains under the hitch when connecting.
- Always use a mechanical retainer through the ball hitch mechanism when attaching to tow vehicle.
- Do not drink and drive.
- Plan your route to avoid rough terrain. Slow down when encountering rough conditions or cornering.
- Raise and secure feed hopper before moving or transporting.

When transporting the machine, review and follow these instructions:

1. Clear the area of bystanders, especially small children.
2. Check that all the lights and reflectors required by the highway authorities are in place, clean and working.
3. Insure that the machine is securely attached to the pick-up with a mechanical retainer through the ball hitch mechanism. Always use safety chains crossed between the truck and machine.
4. Do not allow riders.
5. Never exceed a safe travel speed. Slow down when encountering rough road conditions and cornering.
6. Do not drink and drive.
7. Raise and secure the hopper intake gate before transporting.
8. Turn the discharge hood and point rearward to reduce the width of the machine.



Fig. 28 TRANSPORT CONFIGURATION

4.9 STORAGE



OPERATING SAFETY

- Store the unit in an area away from human activity.
- Do not permit children to play on or around the stored machine.
- Store the unit in a dry, level area. Support the frame with planks if required.

4.9.1 PLACING IN STORAGE

After the season's use or when the machine will not be used for a period of time, completely inspect all major systems of the Commercial Trailer Wood Chipper. Replace or repair any worn or damaged components to prevent any unnecessary down time at the beginning of the next season.

Follow this procedure before storing:

1. Remove all material from the machine.
2. Thoroughly wash the machine with a pressure washer or water hose to remove all dirt, mud or debris.
3. Inspect all rotating parts for entangled material. Remove all entangled material.
4. Check the condition of the belts and pulleys. Replace or adjust as required.
5. Run the machine a few minutes to dry the moisture from inside the machine.
6. Turn fuel valve off.
7. Move the feed hopper intake gate up and lock.
8. Touch up all paint nicks and scratches to prevent rusting.
9. Remove ignition key and store in a secure place.
10. Remove the battery and store it in a cool, dry area on wooden blocks or a wooden pallet. Charge it monthly to maintain an adequate charge.
11. It is best to store the machine inside. If that is not possible, cover with a waterproof tarpaulin and tie down securely.

12. Store in an area away from human activity.
13. Do not allow children to play around the stored unit.

4.9.2 REMOVING FROM STORAGE

When removing this machine from storage, follow this procedure:

1. Remove the tarpaulin if covered.
2. Install and connect the battery.
3. Bring the ignition key.
4. Review and follow the pre-operation checklist.

IMPORTANT

If the machine has been stored for more than 6 months, warm the engine by running it for 2-3 minutes and drain the oil. Change the oil while the oil is warm to remove any condensation. Refer to Maintenance section.



Fig. 29 STORED

5 SERVICE AND MAINTENANCE



MAINTENANCE SAFETY

- Good maintenance is your responsibility. Poor maintenance is an invitation to trouble.
- Follow good shop practices.
 - Keep service area clean and dry.
 - Be sure electrical outlets and tools are properly grounded.
 - Use adequate light for the job at hand.
- Make sure there is plenty of ventilation. Never operate the engine of the towing vehicle in a closed building. The exhaust fumes may cause asphyxiation.
- Before working on this machine, shut off the engine, set the brake, and turn fuel valve off.
- Never work under equipment unless it is blocked securely.
- Always use personal protection devices such as eye, hand and hearing protectors, when performing any service or maintenance work. Use heavy gloves when handling sharp components.
- Where replacement parts are necessary for periodic maintenance and servicing, genuine factory replacement parts must be used to restore your equipment to original specifications. The manufacturer will not be responsible for injuries or damages caused by use of unapproved parts and/or accessories.
- A fire extinguisher and first aid kit should be kept readily accessible while performing maintenance on this equipment.
- Periodically tighten all bolts, nuts and screws and check that all electrical and fuel connections are properly secured to ensure unit is in a safe condition.
- When completing a maintenance or service function, make sure all safety shields and devices are installed before placing unit in service.

5.1 SERVICE

5.1.1 FLUIDS AND LUBRICANTS

1. **Grease:**
Use an SAE multipurpose high temperature grease with extreme pressure (EP) performance. Also acceptable is an SAE multipurpose lithium base grease.
2. **Engine Oil:**
Use an SAE 10W30 or 10W40 multi-viscosity oil meeting the American Petroleum Institute (API) classification of SF, SG, SH or SJ for normal operating temperatures. Consult the engine manual for unusual operating conditions. Do not mix oil types or viscosities.

Crankcase Capacity: 3 L (3.0 US qt)
3. **Engine Gasoline:**
Use a standard automotive unleaded gasoline for all operating conditions.

Fuel Tank Capacity: 50 L (12 US gal)
4. **Hydraulic Oil:**
Use a standard SAE heavy duty hydraulic oil.

Reservoir Capacity: 30 L (7 US gal)
5. **Storing Lubricants:**
Your machine can operate at top efficiency only if clean lubricants are used. Use clean containers to handle all lubricants. Store them in an area protected from dust, moisture and other contaminants.

5.1.2 GREASING

Refer to section 5.1.1 for recommended grease.

Use the Maintenance Checklist provided to keep a record of all scheduled maintenance.

1. Use a hand-held grease gun for all greasing.
2. Wipe grease fitting with a clean cloth before greasing, to avoid injecting dirt and grit.
3. Replace and repair broken fittings immediately.
4. If fittings will not take grease, remove and clean thoroughly. Also clean lubricant passageway. Replace fittings if necessary.

5.1.2 SERVICING INTERVALS

The period recommended is based on normal operating conditions. Severe or unusual conditions may require more frequent lubrication or oil changes.

8 Hours or Daily

1. Check engine oil level.



Fig. 30 DIP STICK

2. Check fuel level.



Fig. 31 FUEL TANK

3. Check oil level in hydraulic tank.

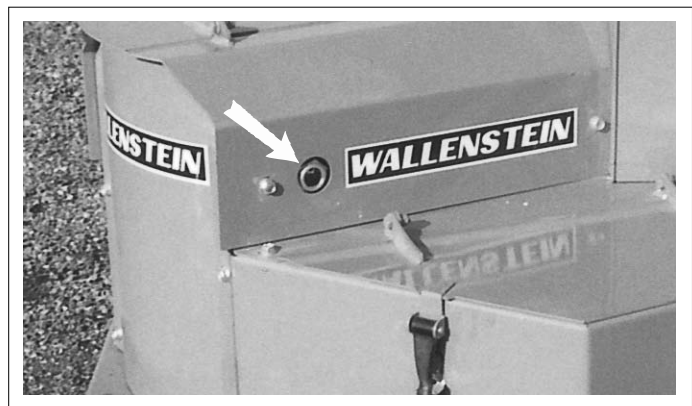

Fig. 32 SIGHT GLASS

40 Hours or Weekly

1. Check rotor drive belt tension. Move the engine to set the belt tension.

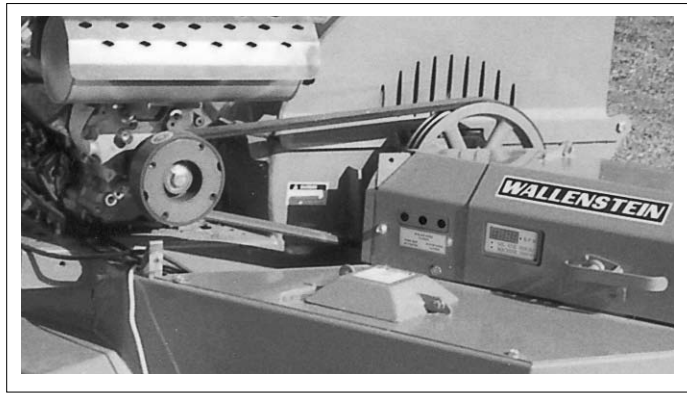

Fig. 33 ROTOR DRIVE SYSTEM

2. Clean engine air cleaner.

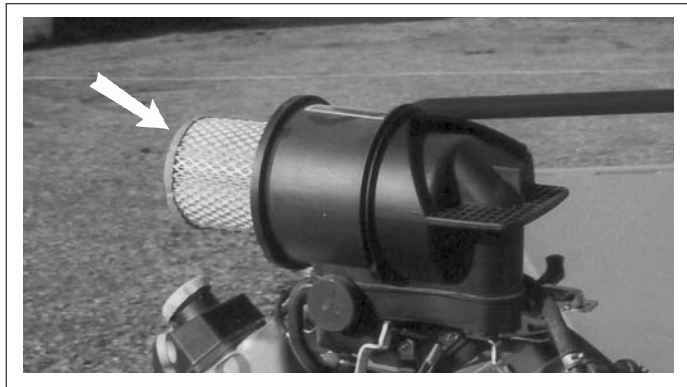

Fig. 34 AIR CLEANER

3. Check sharpness of blades:

- a. Rotor.
- b. Stationary.

Remove, sharpen or change edge as required.

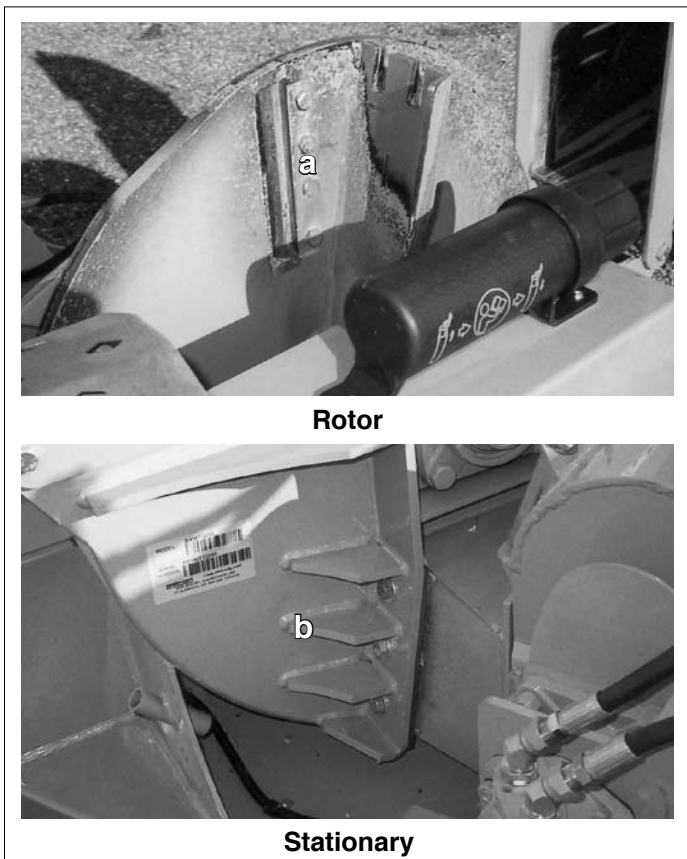

Fig. 35 BLADES

100 Hours or Monthly

1. Change engine oil.



Fig. 36 DRAIN PLUG

2. Check tire pressure.



Fig. 37 TIRES (Typical)

3. Change engine oil filter.

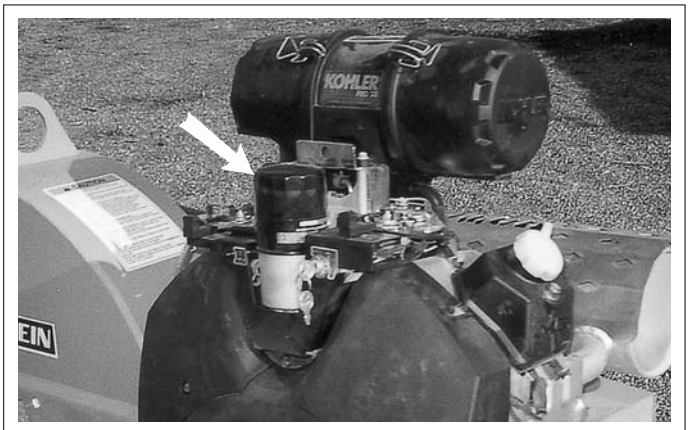

Fig. 38 OIL FILTER

100 Hours

- Grease rotor bearings.

IMPORTANT

Do not over grease.

 **WARNING**

Machine is shown with guard removed or rotor cover opened for illustrative purposes only. Do not operate machine with guard removed or cover opened.

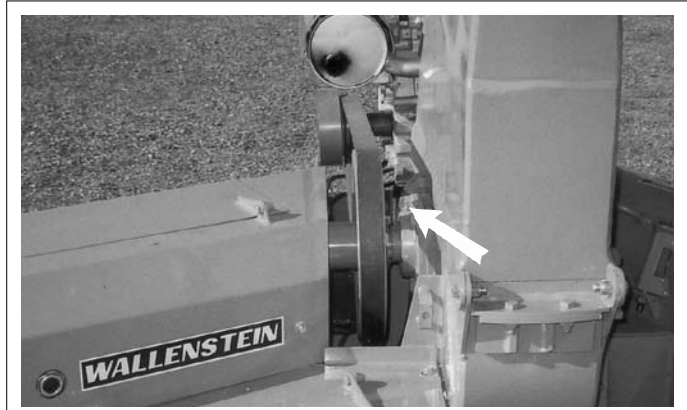

Front

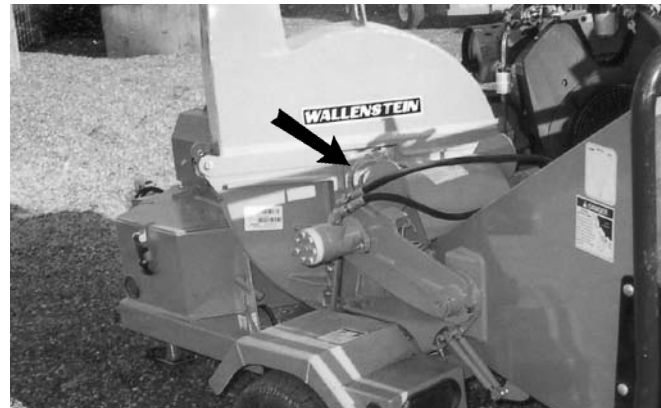

Rear

Fig. 39 BEARINGS

- Replace engine air cleaner.

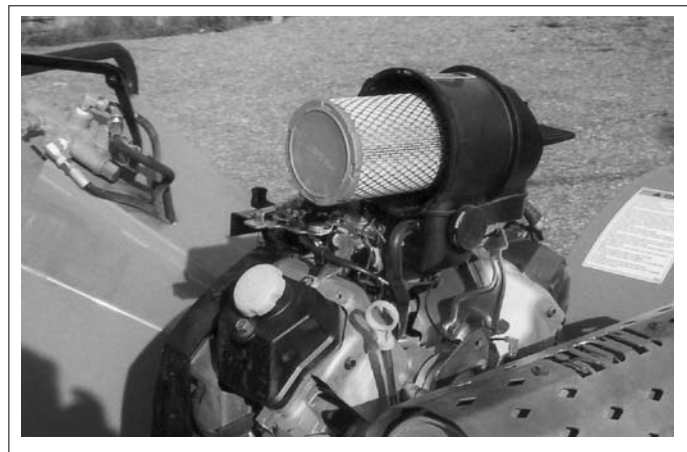

Fig. 40 AIR CLEANER

6. Grease feed roller bearings.
7. Grease the feed roller pivot.

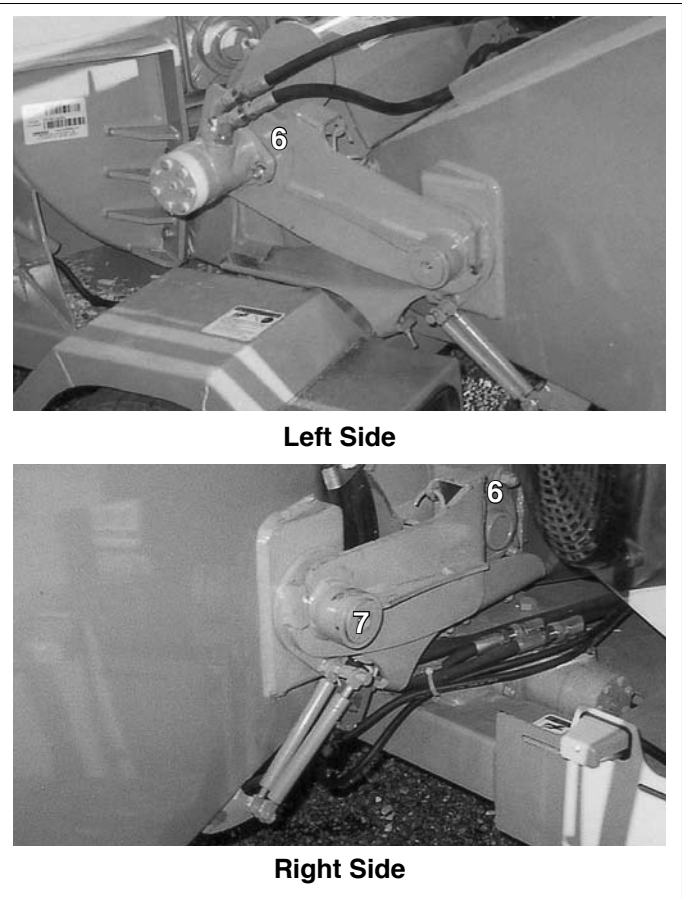

Fig. 41 FEED ROLLER

Annually

- 1. Replace in-line fuel filter.

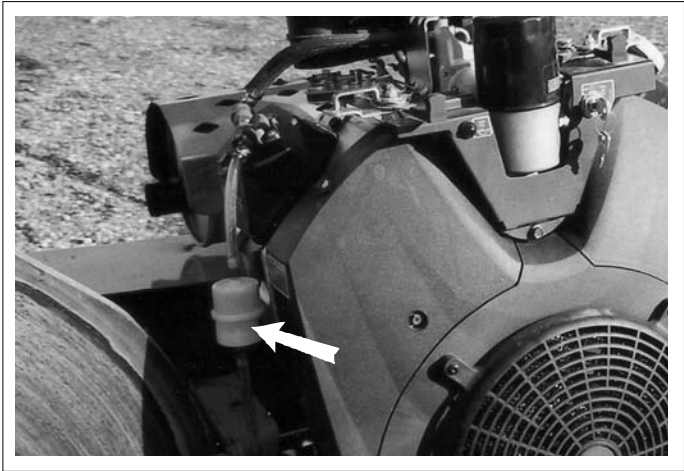

Fig. 42 FUEL FILTER

- 2. Replace hydraulic filter.

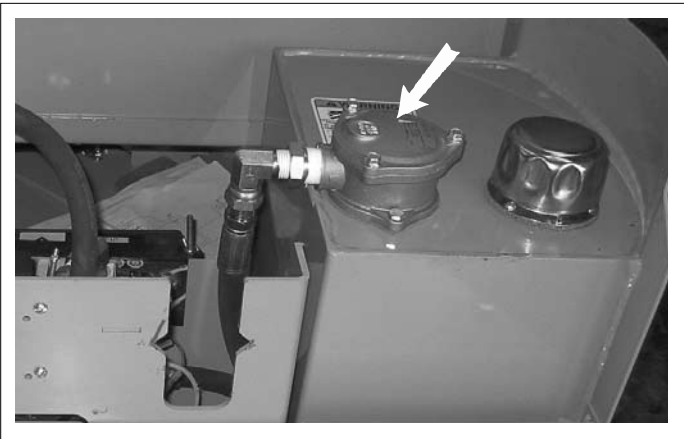

Fig. 43 HYDRAULIC FILTER

- 3. Clean machine.



Fig. 44 MACHINE

5.1.3 SERVICE RECORD

See Lubrication and Maintenance sections for details of service. Copy this page to continue record.

ACTION CODE CK CHECK CL CLEAN R REPLACE
 G GREASE CH CHANGE

MAINTENANCE	HOURS												
	SERVICED BY												
8 Hours or Daily													
CK	Engine Oil Level												
CK	Fuel Level												
CK	Hydraulic Oil Level												
40 Hours or Weekly													
CK	Rotor Drive Belt Tension												
CL	Air Cleaner												
CK	Blade Sharpness												
100 Hours or Monthly													
CH	Engine Oil												
CK	Tire Pressure												
CH	Engine Oil Filter												
G	Rotor Bearings												
R	Engine Air Cleaner												
G	Feed Roller Bearings												
G	Feed Roller Pivot												
Annually													
R	In-Line Fuel Filter												
R	Hydraulic Filter												
CL	Machine												

5.2 MAINTENANCE

By following a careful service and maintenance program for your machine, you will enjoy many years or trouble-free operation.

5.2.1 CLEANING AIR CLEANER

1. Review the Operator's Manual for the engine.
2. Place all controls in neutral, stop engine and remove ignition key and wait for all moving parts to stop before maintaining.
3. Remove the cover over the air cleaner.
4. Remove the filter from the engine.
5. Use an air house to blow the dust and debris out of the filter.
6. Install filter.
7. Install and secure the cover.



Fig. 45 AIR CLEANER

5.2.2 CHANGING ENGINE OIL AND FILTER

1. Review the Operator's Manual for the engine.
2. Place all controls in neutral, stop engine and remove ignition key and place in pocket before maintaining.
3. Allow the engine to cool before changing the oil. Hot oil can cause burns if it contacts exposed skin. It is best to change oil while the engine is warm to keep the contaminants in suspension.
4. Place a pan under the drain plug.
5. Remove the drain plug and allow the oil to drain for 10 minutes.
6. Install and tighten the drain plug.
7. Dispose of the used oil in an approved container.
8. Remove engine oil filter.
9. Apply a light coat of oil to the O ring and install the replacement filter. Snug up by hand and then tighten 1/2 turn.
10. Fill the crankcase with the specified oil.
11. Run the engine for 1-2 minutes and check for oil leaks.
12. If leaks are found around the drain plug or filter, tighten slightly. Repeat step 9.
13. Check engine oil level. Top up as required.

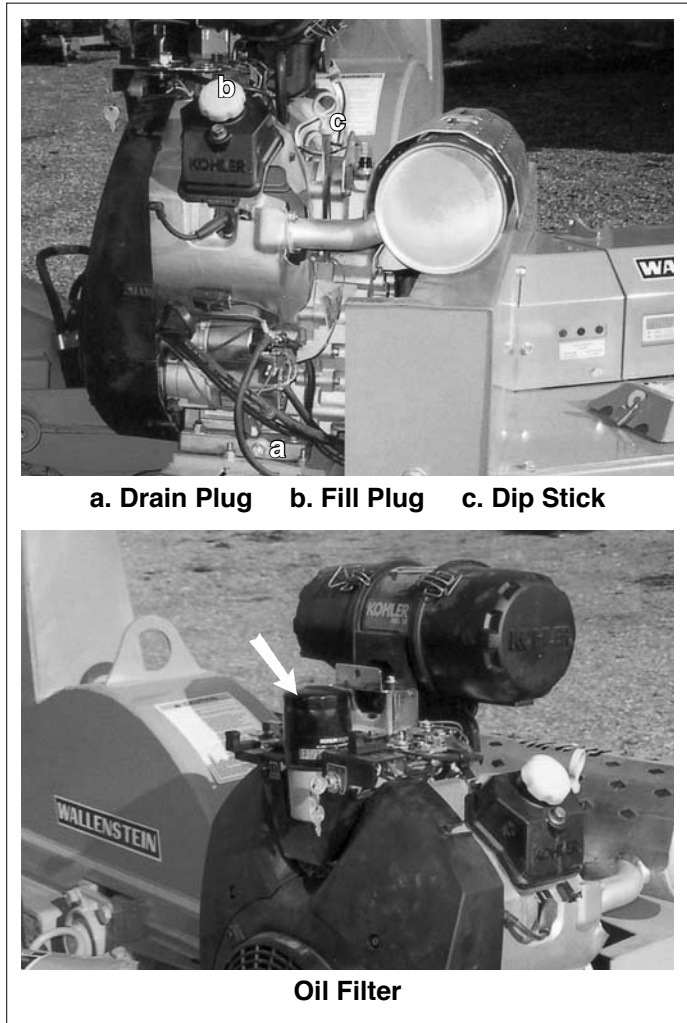

Fig. 46 ENGINE OIL

5.2.3 DRIVE BELT TENSION AND ALIGNMENT

A V belt transmits rotational power to the rotor. It must be kept properly tensioned and the pulleys aligned to obtain the expected performance and life.

To check the tension and alignment, follow this procedure:

1. Clear the area of bystanders, especially small children.
2. Turn machine off, stop engine, remove ignition key and wait for all moving parts to stop.
3. Remove guard over belt.
4. Push on the belt in the center of the span. The belt should deflect approximately 1 inch (25 mm) when pushed on with about 10 lbs. force to be properly tensioned.

IMPORTANT

The belt should not slip when the chipper is being used.

5. **To adjust belt tension:**
 - a. Loosen engine mounting bolts.
 - b. Move the engine to the required position to set belt tension.
 - c. Set pulley alignment.
 - d. Tighten mounting bolts to their specified torque.
6. **To replace belt:**
 - a. Move engine to its loosest position.
 - b. Replace belt.
 - c. Set pulley alignment.
 - d. Tighten engine mounting bolts to their specified torque.
 - e. Check frequently during the first 10 hours and set belt tension as required.

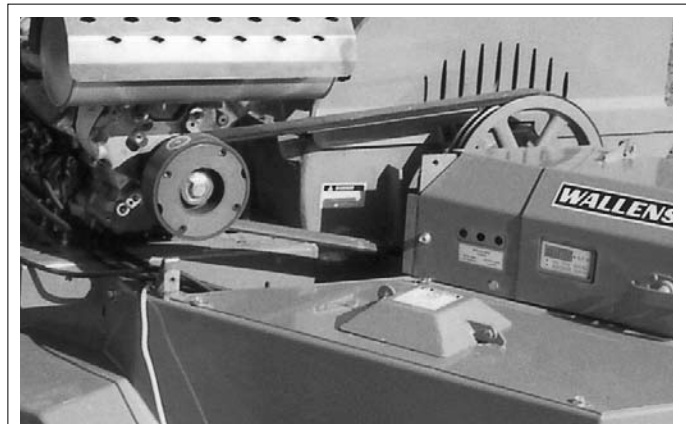

Belt System

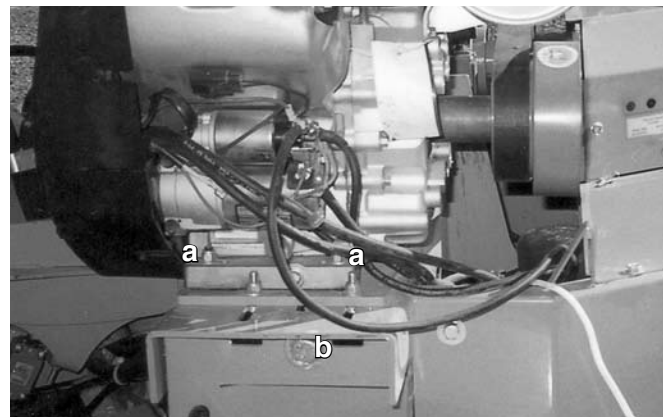

a. Engine Mounting Bolts b. Adjusting Bolt

Fig. 47 BELT DRIVE SYSTEM



7. Lay a straight edge across the pulley faces to check the alignment. Adjust alignment if pulley faces vary more than 1/32 inch (.8 MM).

 **WARNING**

Machine is shown with guard removed or rotor cover opened for illustrative purposes only. Do not operate machine with guard removed or cover opened.



Fig. 48 PULLEY ALIGNMENT

6 TROUBLE SHOOTING

The Wallenstein Commercial Trailer Wood Chipper is designed with blades on a rotor to cut, shear and shred wooden material. It is a simple and reliable system that requires minimal maintenance.

In the following section, we have listed many of the problems, causes and solutions to the problems that you may encounter.

If you encounter a problem that is difficult to solve, even after having read through this trouble shooting section, please call your local distributor or dealer. Before you call, please have this Operator's Manual from your unit and serial number ready.

PROBLEM	CAUSE	SOLUTION
Rotor does not turn.	Obstructed discharge.	Shut down and clear debris.
	Rotor plugged.	Clear rotor.
	Belt loose or broken.	Adjust or replace belt.
Slow feeding.	Knives are dull.	Sharpen knives.
	Blade angle wrong, improper angle.	Re-sharpen knives to specified angle.
	Discharge hood clogged.	Clear discharge hood.
Chipper requires excessive power or stalls.	Obstructed discharge.	Clear discharge hood.
	Rotor plugged.	Clear rotor.
	Green material will not discharge.	Allow material to dry or alternately feed in dry material.
	Knives dull.	Sharpen knives.
Drive belts slipping or smoking.	Loose or worn belts.	Adjust or replace belts.
	Plugged rotor.	Clear rotor.
Engine dies or runs poorly.	Engine problems.	Refer to engine operator's manual or contact your local engine dealer.
Vibration while running.	Driveline vibration.	Check drive belts or pulleys for bad spots or wear. Inspect rotor for broken or missing chipper knives. Repair if required
		Check rotor to see if it wobbles. Check to see if rotor is assembled correctly.

PROBLEM**CAUSE****SOLUTION**

Feed rollers do not turn.

Low hydraulic oil.

Add oil to reservoir.

Plugged hydraulic filter.

Replace filter.

Controller isn't working.

Check electrical system.

Charge battery.

Replace controller.

Sensor not working.

Check sensor and set to
2 mm (3/16 inch) clearance.

Replace sensor

Rotor stalls.

Feed rollers not stopping.

Controller not sensing rotor
speed. Check sensor, electrical
and hydraulic systems.

7 SPECIFICATIONS

7.1 MECHANICAL

	CR60
Drive system	Belt drive. centrifugal clutch.
Engine	38 hp Kohler
Chipper Capacity	6" Diameter (takes up to 10" slab).
Chipper Housing Opening	6 1/2" by 12"
Rotor Size	30"
Number of Rotor Knives	2
Knife Type	Hardened tool steel
Rotor Weight	180 lbs.
Feeding System	Self feed.
Mounting System	Trailer.
Dimensions (Hopper Folded)	63" W x 88" L x 91" H
Hopper Opening	25" by 25"
Discharge Hood Rotation	360°
Discharge Hood Height	72"
Rated RPM	1280
Weight	1355 lbs.

SPECIFICATIONS SUBJECT TO CHANGE WITHOUT NOTICE

7.2 BOLT TORQUE

CHECKING BOLT TORQUE

The tables shown below give correct torque values for various bolts and capscrews. Tighten all bolts to the torques specified in chart unless otherwise noted. Check tightness of bolts periodically, using bolt torque chart as a guide. Replace hardware with the same strength bolt.

ENGLISH TORQUE SPECIFICATIONS

Bolt Diameter "A"	Bolt Torque*					
	SAE 2 (N.m) (lb-ft)		SAE 5 (N.m) (lb-ft)		SAE 8 (N.m) (lb-ft)	
1/4"	8	6	12	9	17	12
5/16"	13	10	25	19	36	27
3/8"	27	20	45	33	63	45
7/16"	41	30	72	53	100	75
1/2"	61	45	110	80	155	115
9/16"	95	60	155	115	220	165
5/8"	128	95	215	160	305	220
3/4"	225	165	390	290	540	400
7/8"	230	170	570	420	880	650
1"	345	225	850	630	1320	970

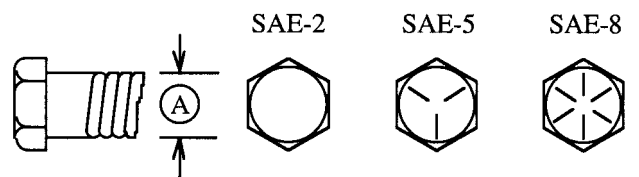

METRIC TORQUE SPECIFICATIONS

Bolt Diameter "A"	Bolt Torque*			
	8.8 (N.m) (lb-ft)		10.9 (N.m) (lb-ft)	
M3	.5	.4	1.8	1.3
M4	3	2.2	4.5	3.3
M5	6	4	9	7
M6	10	7	15	11
M8	25	18	35	26
M10	50	37	70	52
M12	90	66	125	92
M14	140	103	200	148
M16	225	166	310	229
M20	435	321	610	450
M24	750	553	1050	774
M30	1495	1103	2100	1550
M36	2600	1917	3675	2710

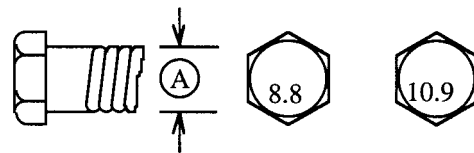

Torque figures indicated above are valid for non-greased or non-oiled threads and heads unless otherwise specified. Therefore, do not grease or oil bolts or capscrews unless otherwise specified in this manual. When using locking elements, increase torque values by 5%.

* Torque value for bolts and capscrews are identified by their head markings.

7.3 HYDRAULIC FITTING TORQUE

Tightening Flare Type Tube Fittings *

1. Check flare and flare seat for defects that might cause leakage.
2. Align tube with fitting before tightening.
3. Lubricate connection and hand tighten swivel nut until snug.
4. To prevent twisting the tube(s), use two wrenches. Place one wrench on the connector body and with the second tighten the swivel nut to the torque shown.

Tube Size OD (in.)	Nut Size Across Flats (in.)	Torque Value*		Recommended Turns To Tighten (After Finger Tightening)	
		(N.m)	(lb-ft)	(Flats)	(Turn)
3/16	7/16	8	6	1	1/6
1/4	9/16	12	9	1	1/6
5/16	5/8	16	12	1	1/6
3/8	11/16	24	18	1	1/6
1/2	7/8	46	34	1	1/6
5/8	1	62	46	1	1/6
3/4	1-1/4	102	75	3/4	1/8
7/8	1-3/8	122	90	3/4	1/8

- The torque values shown are based on lubricated connections as in reassembly.

8 INDEX

I	PAGE
Index.....	57
Introduction.....	1

O	
Operation.....	16
Attaching/Unhooking.....	23
Controls.....	19
Field Operation.....	25
Machine Break-In.....	18
Machine Components.....	17
Pre-Operation Checklist.....	18
Storage.....	39
To the New Operator or Owner.....	16
Transporting.....	38

S	PAGE
Safety.....	2
Battery Safety.....	10
Equipment Safety Guidelines.....	4
Gas Motor Safety.....	9
General Safety.....	3
Maintenance Safety.....	6
Operating Safety.....	7
Preparation.....	6
Safety Signs.....	5
Safety Training.....	5
Sign-Off Form.....	11
Storage Safety.....	8
Transporting.....	10
Safety Sign Locations.....	12
Service and Maintenance.....	40
Maintenance.....	48
Service.....	40
Specifications.....	54
Bolt Torque.....	55
Hydraulic Fitting Torque.....	56

T	
Trouble Shooting.....	52

WALLENSTEIN

**4144 BOOMER LINE
ST. CLEMENTS, ON
N0B 2M0 CANADA
PH: (519) 699-9283
FAX: (519) 699-4146**