

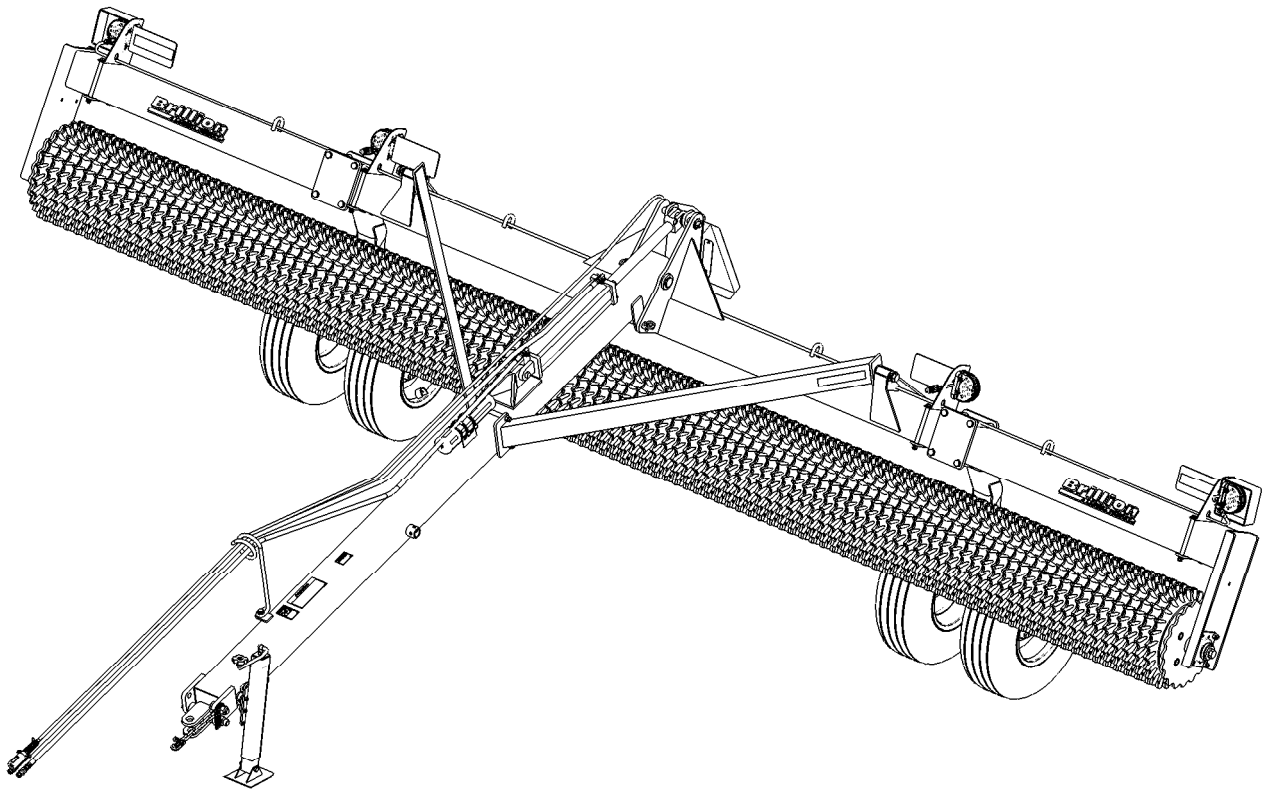

Floating Ring Pulverizer PFT 20' and 22' Models Operator's Manual



LANDOLL CORPORATION

1900 North Street
Marysville, Kansas 66508
(785) 562-5381

800-428-5655 ~ WWW.LANDOLL.COM

Table of Contents

1 Introduction and Safety Information

Introduction	1-1
Description of Unit	1-1
Owner Assistance	1-1
Warranty Registration	1-1
Safety	1-2
Transporting Safety	1-3
Attaching, Detaching and Storage	1-3
Maintenance Safety	1-3
Protective Equipment	1-3
High Pressure Fluid Safety	1-3
Prepare for Emergencies	1-3
Tire Safety	1-3
Safety Chain	1-4
Decals	1-5

2 Assembly

Roller and Frame	2-2
Drawbar Installation	2-3
Optional Bridge Hitch Installation	2-5
Bridge Hitch Brace Installation	2-5
Wheel Arm Assembly	2-7
Hydraulic Circuit Installation	2-9
Bridge Hitch Hydraulic Circuit Installation	2-9
LED Lights Installation	2-12

3 Operation

Parking	3-4
Attaching to Equipment	3-4
Hitching the Bridge Hitch	3-4
Unhitching/Parking Pulverizer with Bridge Hitch	3-4
Transport Lock	3-5
Bridge Hitch Transport Lock	3-6
Field Operations	3-7
Roller Orientation	3-7
Reflectors and SMV Sign	3-8
LED 7-Pin AG Connector	3-8

4 Maintenance

General Torque Specifications	4-1
Hydraulic Fitting Torque Specifications	4-2
Fasteners	4-3
Lubrication	4-3
Tires	4-3
Hydraulic System	4-4
Replacing or Adding Roller Wheels	4-4

5 General Reference and Specifications

Introduction and Safety Information

Introduction

The implement described in this manual has been designed with care and built by skilled workers using quality materials and processes. Proper assembly and maintenance will provide you with satisfactory use for seasons to come.



DANGER

Read this entire manual before attempting to assemble, adjust or operate this implement. Failure to comply with this warning can result in personal injury or death, damage to the implement or its components and inferior operation.

Description of Unit

The Brillion Floating Ring Series was designed as a companion tool for use behind a primary tillage machine to firm and level the soil into a plantable medium. The ability of the Pulverizer rings to move on the drum provides a self-cleaning feature that lends itself to efficient operation even in moist conditions. The floating rings follow the rugged soil contours found after using a primary tillage machine.

Using this Manual

This manual will familiarize you with safety, assembly, operation, adjustment, and maintenance. Read this manual and follow the recommendations to help ensure safe and efficient operation.

- The information in this manual is current at time of printing. Some parts may have changed to assure top performance.
- Location reference: Right and Left designations in this manual are determined by facing the direction the implement will travel during field operation, unless otherwise stated.

Owner Assistance

If customer service or repairs are needed, contact your Brillion dealer. They have trained personnel, parts and service equipment specially designed for Brillion products. Your implement's parts should only be replaced with Brillion parts. If items covered in this manual are not understood, contact your local Brillion Dealer.

Warranty Registration

Brillion Farm Equipment, by Landoll, shall have no warranty obligation unless each product is registered within 10 days of retail purchase, using the Landoll Corporation Ag Products on-line registration process. Please refer to the Ag Products Policy and Procedures Manual, accessible at www.landoll.com for step by step instructions regarding product registration.

Enter your product information below for quick reference.

MODEL NUMBER _____

SERIAL NUMBER _____

DATE OF PURCHASE _____

Refer to the ID plate as shown. See Figure 1-1.

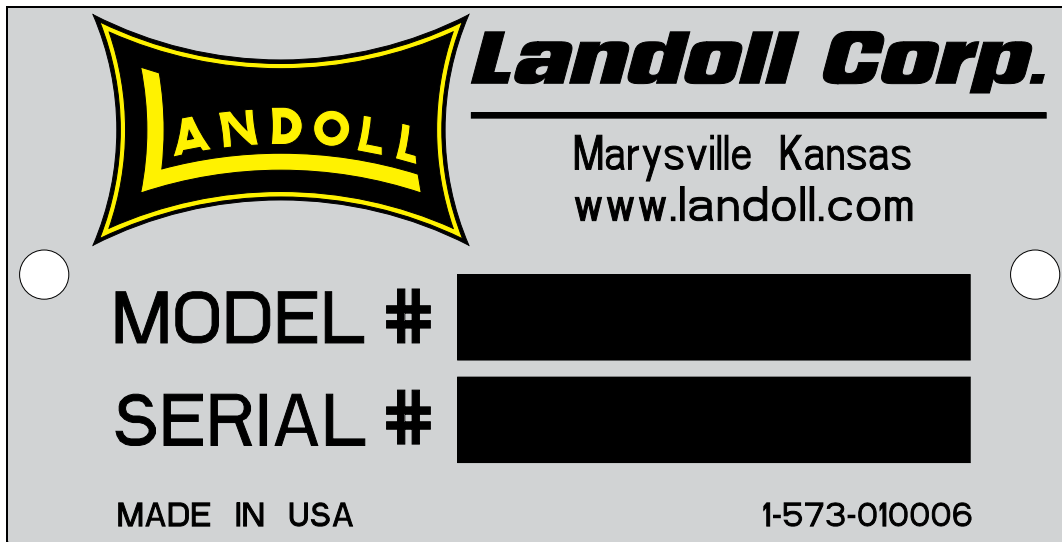

Figure 1-1: ID Plate

Safety

NOTE

Investigation has shown that nearly 1/3 of all farm accidents are caused by careless use of machinery. Insist that all people working with you or for you abide by all safety instructions.

You will find various types of safety information on the following pages and on the implement decals (signs) attached to the implement. This section explains their meaning.

NOTICE

Special notice - read and thoroughly understand.



CAUTION

Proceed with caution. Failure to heed caution may cause injury to person or damage product.



WARNING

Proceed with caution. Failure to heed warning will cause injury to person or damage product.



DANGER

Proceed with extreme caution. Failure to heed notice will cause injury or death to person and/or damage product.

NOTE

You should read and understand the information contained in this manual and on the implement decals before you attempt to operate or maintain this equipment.

Examine safety decals and be sure you have the correct safety decals for the implement. **See Figure 1-4.**

Order replacement decals through your Brillion dealer.

Keep these signs clean so they can be observed readily. It is important to keep these decals cleaned more frequently than the implement. Wash with soap and water or a cleaning solution as required.

Replace decals that become damaged or lost. Also, be sure that any new implement components installed during repair include decals which are assigned to them by the manufacturer.

When applying decals to the implement, be sure to clean the surface to remove any dirt or residue. Where possible, sign placement should protect the sign from abrasion, damage, or obstruction from mud, dirt, oil etc.



DANGER

- Do not allow anyone to ride on the tractor or implement. Riders could be struck by foreign objects or thrown from the implement.
- Never allow children to operate equipment.
- Keep bystanders away from implement during operation.

Transporting Safety

IMPORTANT

It is the responsibility of the owner/operator to comply with all state and local laws.

When transporting the implement on a road or highway, use adequate warning symbols, reflectors, lights and slow moving vehicle sign as required. Slow moving tractors and towed implements can create a hazard when driven on public roads. They are difficult to see, especially at night.

Do not tow an implement that, when fully loaded, weighs more than 1.5 times the weight of the towing vehicle.

Carry reflectors or flags to mark the tractor and implement in case of breakdown on the road.

Do not transport at speeds over 20 MPH under good conditions. Never travel at a speed which does not allow adequate control of steering and stopping. Reduce speed if towed load is not equipped with brakes

Avoid sudden stops or turns because the weight of the implement may cause the operator to lose control of the tractor. Use a tractor heavier than the implement.

Use caution when towing behind articulated steering tractors; fast or sharp turns may cause the implement to shift sideways.

Keep clear of overhead power lines and other obstructions when transporting. Know the transport height and width of your implement.

Attaching, Detaching and Storage

- Do not stand between the tractor and implement when attaching or detaching implement unless both are blocked from moving.
- Block implement so it will not roll when unhitched from the tractor.

Maintenance Safety

- Block the implement so it will not roll when working on or under it to prevent injury.
- Do not make adjustments or lubricate the machine while it is in motion.

- Make sure all moving parts have stopped.
- Understand the procedure before doing the work. Use proper tools and equipment.

Protective Equipment

- Wear protective clothing & equipment appropriate for the job. Avoid loose fitting clothing.
- Because prolonged exposure to loud noise can cause hearing impairment or hearing loss, wear suitable hearing protection, such as earmuffs or earplugs.

High Pressure Fluid Safety

Escaping fluid under pressure can be nearly invisible and have enough force to penetrate the skin causing serious injury. Use a piece of cardboard, rather than hands, to search for suspected leaks.

Any fluid injected into the skin must be surgically removed within a few hours or gangrene may result.

Avoid the hazard by relieving pressure before disconnecting hydraulic lines.

Prepare for Emergencies

- Keep a First Aid Kit and Fire Extinguisher handy.
- Keep emergency numbers for the doctor, ambulance, hospital and fire department near the phone.

Tire Safety

Tire changing can be dangerous and should be performed by trained personnel using correct tools and equipment.

When inflating tires, use a clip-on chuck and extension hose long enough to allow you to stand to one side, not in front of or over the tire assembly. Use a safety cage if available.

When removing and installing wheels use wheel-handling equipment adequate for the weight involved.

Safety Chain

Use the safety chain to help control drawn machinery should it separate.

Use a chain with a strength rating equal to or greater than the gross weight of towed machinery, which is 11,000 pounds minimum in accordance with ASAE S338.2 specifications. If two or more implements are pulled in tandem, a larger chain may be required. Chain capacity must be greater than the TOTAL weight of all towed implements.

A second chain should be used between each implement.

Attach the chain to the specified location. Allow only enough slack in the chain to permit turning. **See Figure 1-2.**

Replace the chain if any links or end fittings are broken, stretched or damaged.

Do not use a safety chain for towing.

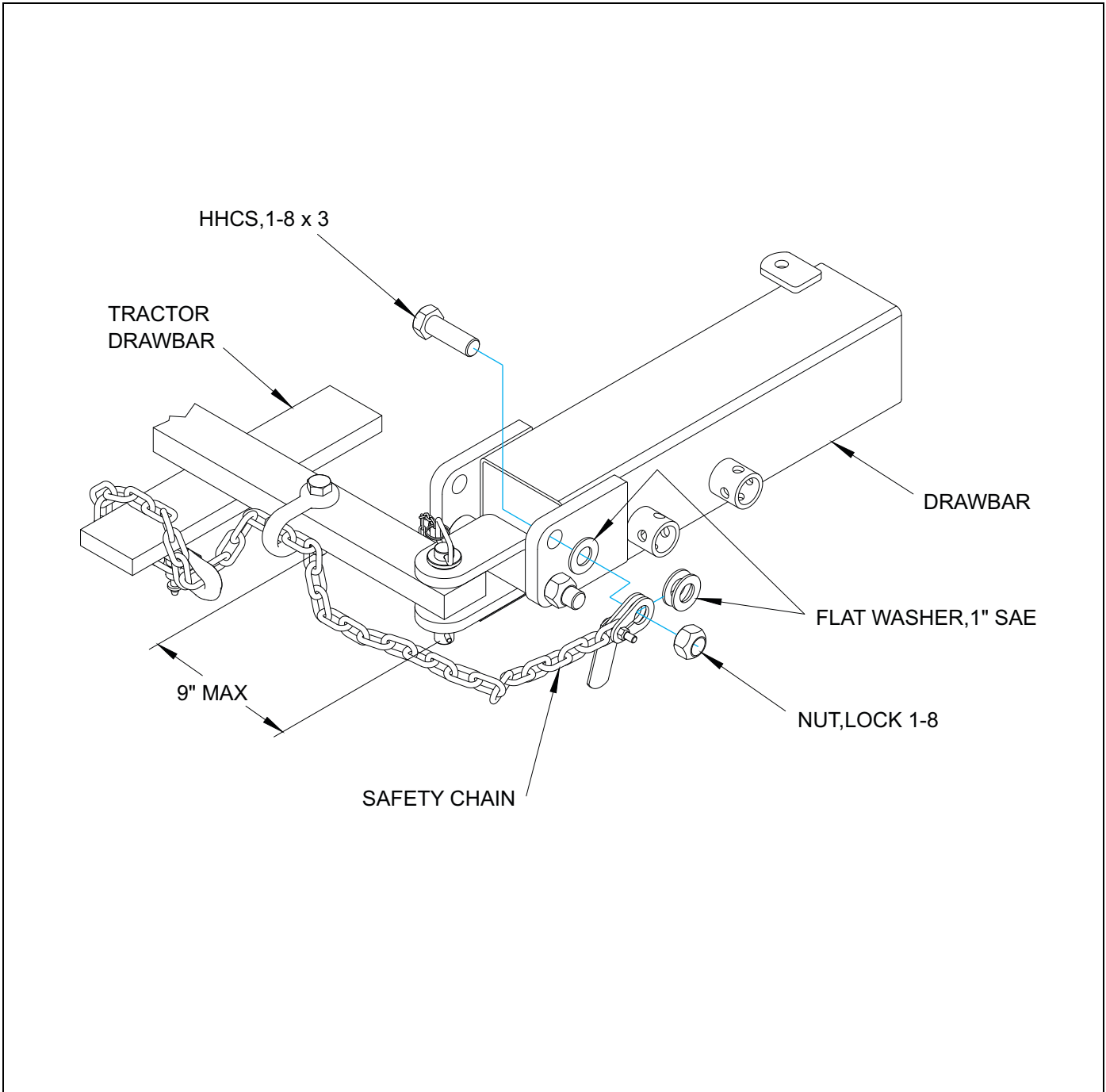

Figure 1-2: Safety Chain

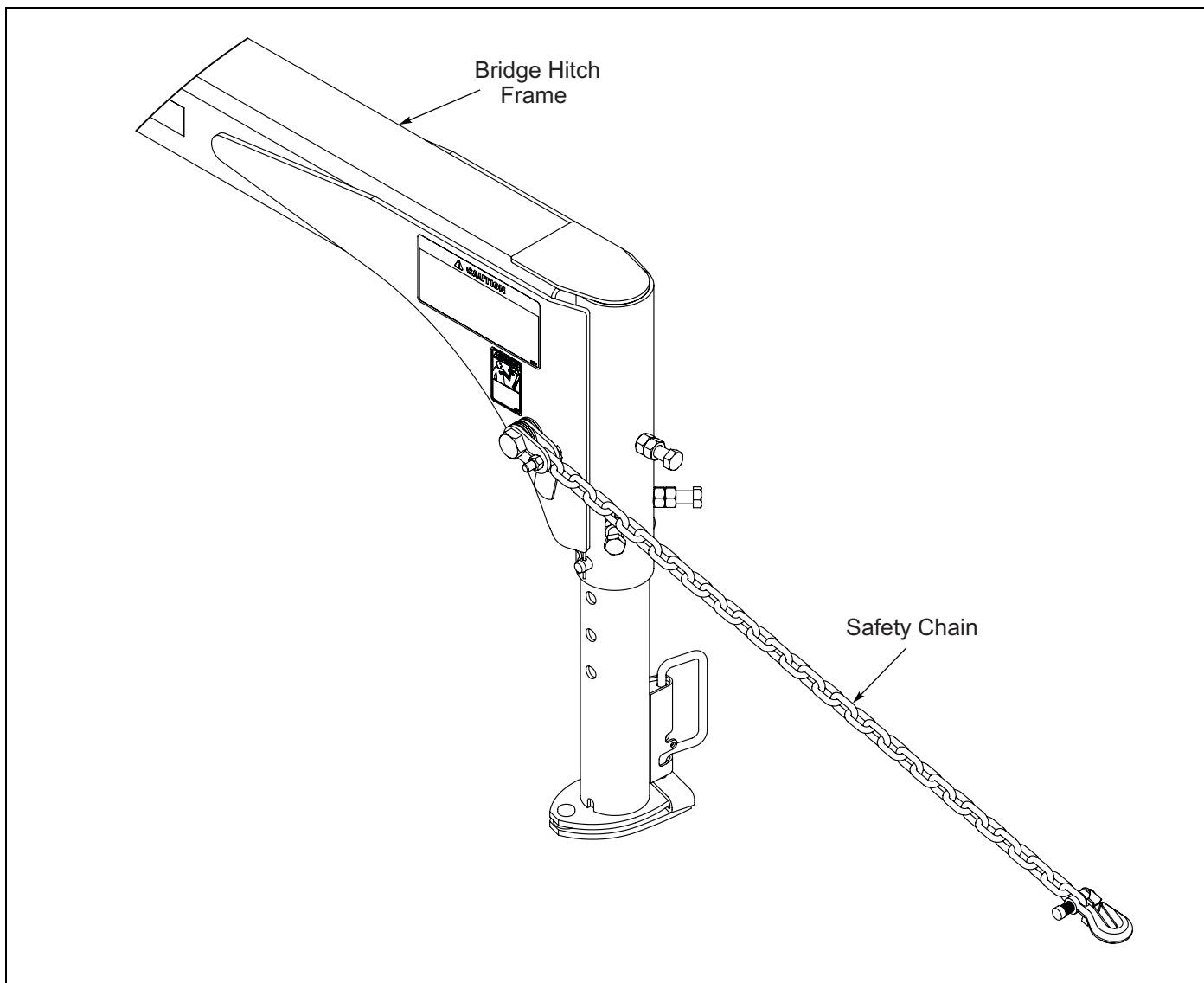
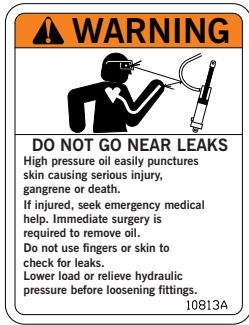

Figure 1-3: Bridge Hitch Safety Chain

Decals



3K706



8J310

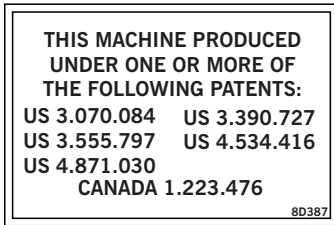

8D387



8J309



528933



528938



528934



170510



4K039

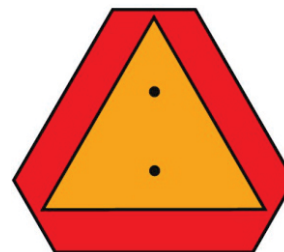

2P151

Figure 1-4: Decals

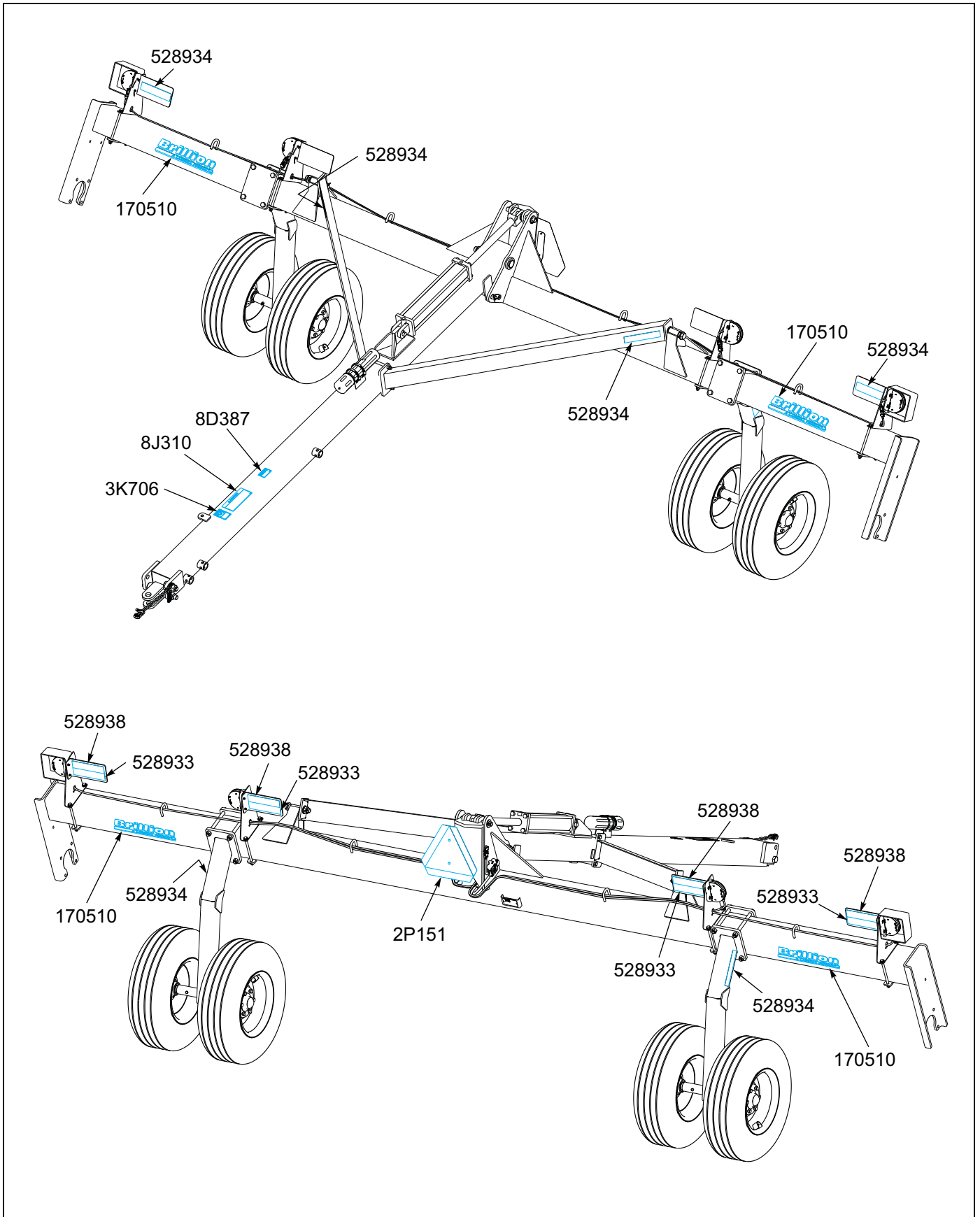

Figure 1-5: Decal Locations 1 of 2

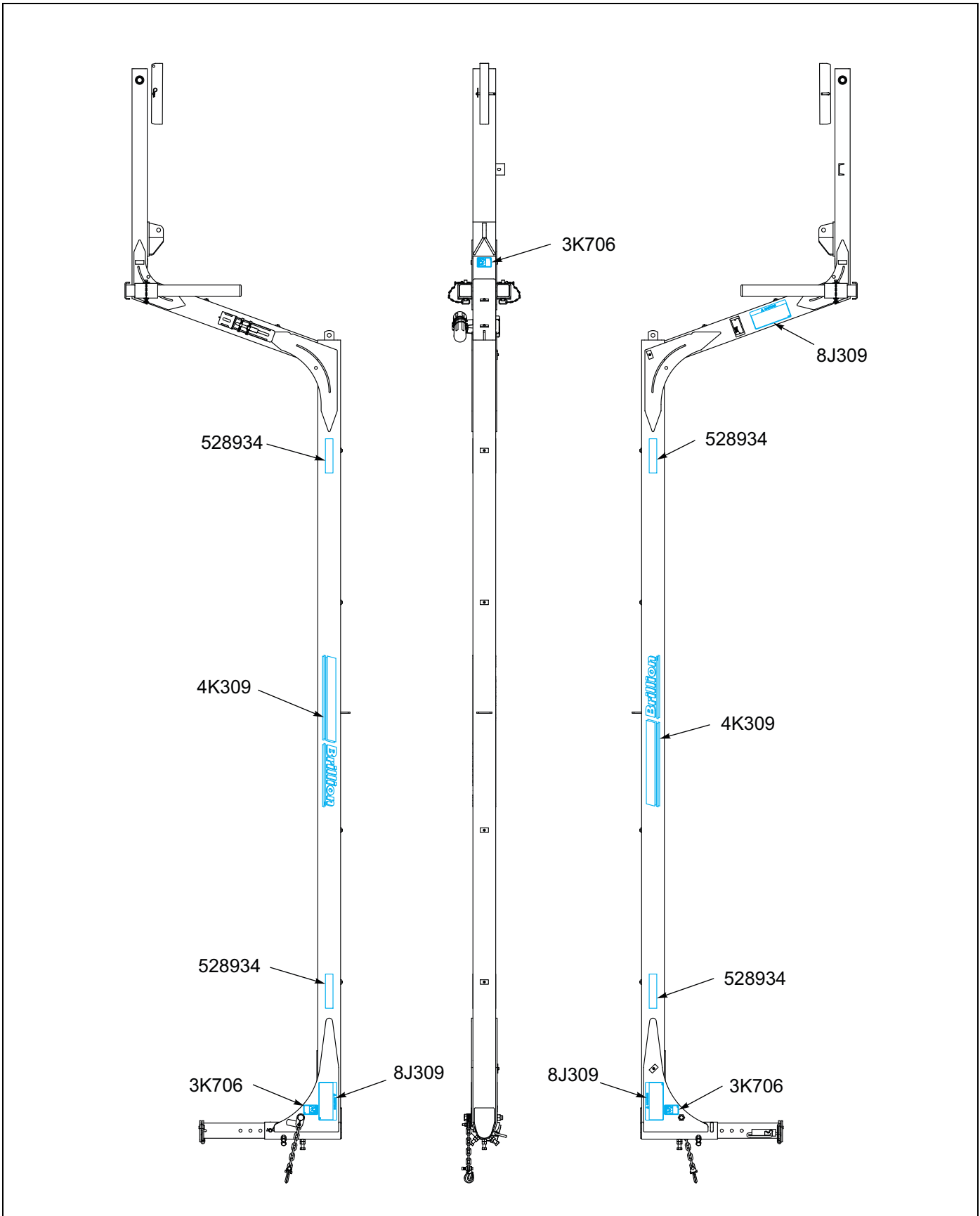

Figure 1-6: Decal Locations, 2 of 2 - Optional Bridge Hitch

Chapter 2

Assembly

This chapter covers proper assembly of your Floating Ring Pulverizer. Refer to the Floating Ring Pulverizer Parts Manual F-779 for complete part breakdowns and proper location of any parts not shown in the following illustrations.

NOTE

The machine shown in the following illustrations may not agree with the size of your unit. Assembly of machines, however, is similar on all models. Additional parts identification and location can be obtained by reviewing the parts manual.



WARNING

Do not work on or under this machine unless securely blocked and supported by a hoist or tractor or by other sufficient means.

IMPORTANT

- If pre-assembled parts or fasteners are temporarily removed, remember where they go. It is best to keep the parts separated.
- Check that all working parts move freely, bolts are tight and cotter pins are spread.
- Refer to the Torque Table for proper bolt torque values. Note the different torque requirement for bolts with lock nuts. **See Page 4-1.**

“Left” and “Right” refer to directions seen as if standing behind the machine and facing in the direction of forward travel.

Roller and Frame

The Roller and Frame are pre-assembled at the factory. Select a smooth, level area that can be reached by a hoist or lift truck.

Place blocks both behind and in front of the roller wheels. Using an overhead hoist, raise the frame so that it is about 16 inches off the ground. Use at least three blocks to secure the frame in this position.

See Figure 2-1.

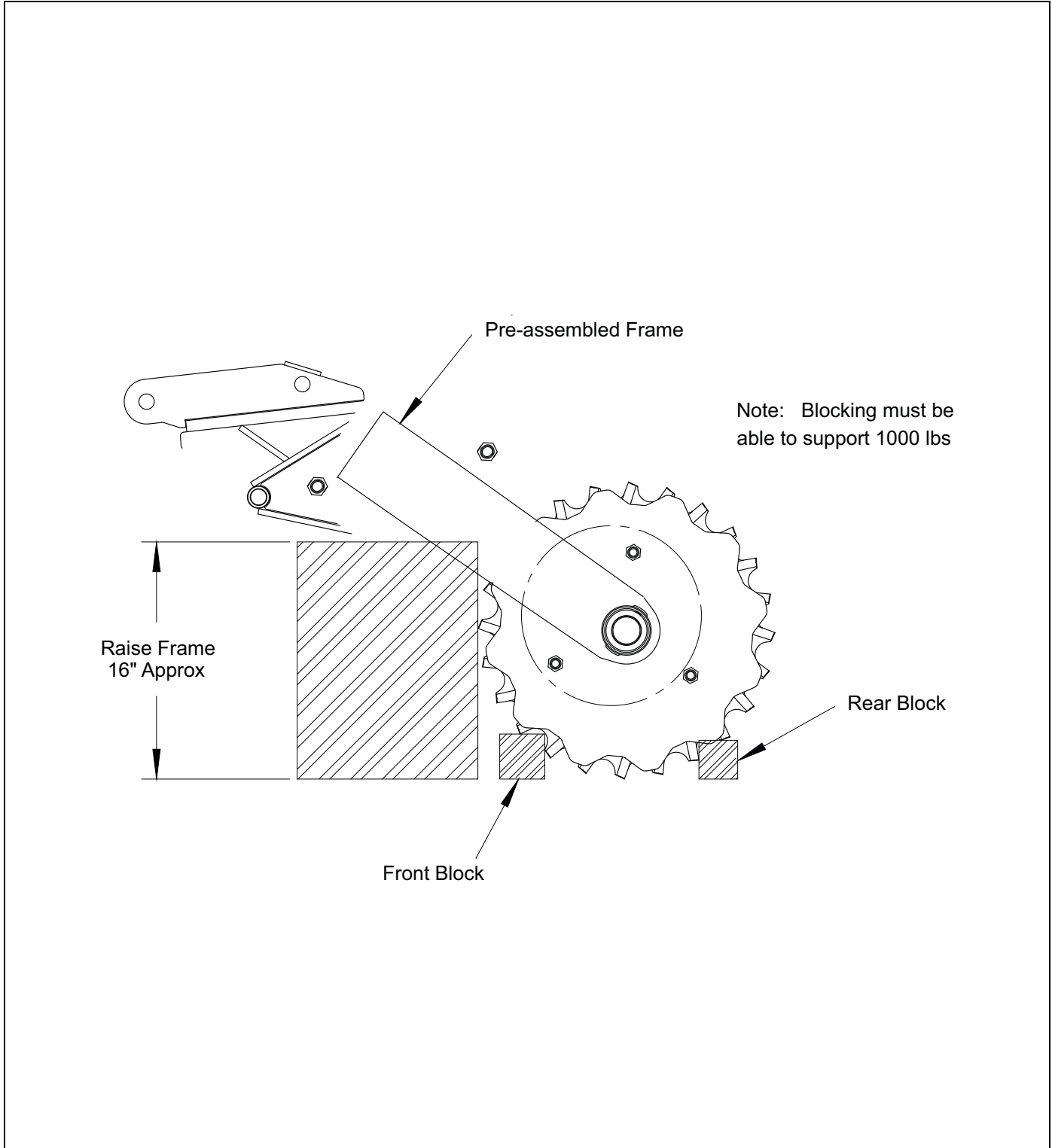

Figure 2-1: Roller and Frame Assembly

Drawbar Installation

Optional Bridge Hitch Installation, **See Page 2-6.**

Bring the rear of the Drawbar into position between the Frame Hitch Plates at the center of the Frame. Place two 1-1/4 x 1-7/8 x 14 ga Machinery Bushings on each side between the Drawbar and the Frame Hitch Plates. Attach the Drawbar to the Frame with 1-1/4-7 x 10-1/2 Bolt and Locknut. *The locknut should be tightened so that the frame is free to pivot on the drawbar.* **See Figures 2-3 and 2-4.**

Attach the braces to the inside of the Frame Brace Lugs. Insert a 1-8 x 6 Drilled Bolt through one 1 inch Flat Washer, then through the frame, add another 1 inch Flat Washer before extending the Bolt through the brace on the frame, finally add one more 1 inch Flat Washer. Secure with Slotted Nut and 1/4 x 2 Cotter Pin. The Slotted Nut should be tightened so the Cotter Pin can be inserted in the second drilled hole. **See Figures 2-2 and 2-4.**

Rotate the braces so they are in line and against the Drawbar. Insert 5/8-11 x 8 Bolts through the holes in the braces above and below the Drawbar and secure with Locknuts. *These nuts should be tightened securely (110 Ft-Lbs).*

Attach Transport Lock Pin and Lynch Pin into Locked Position on the frame. **See Figure 2-3.**

Mount the Hose Support to the Drawbar using 5/8-11 x 2-1/4 Bolt, 3/8 Thick Washer and Locknut.

Attach the Jack to the Drawbar using the pin provided.

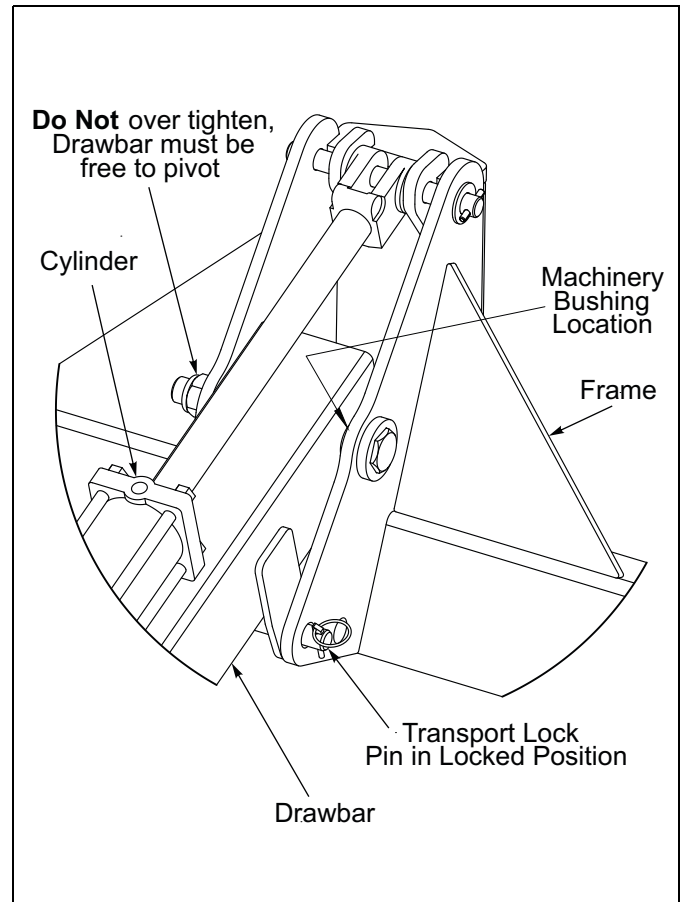

Figure 2-3: Drawbar to Hitch Plates

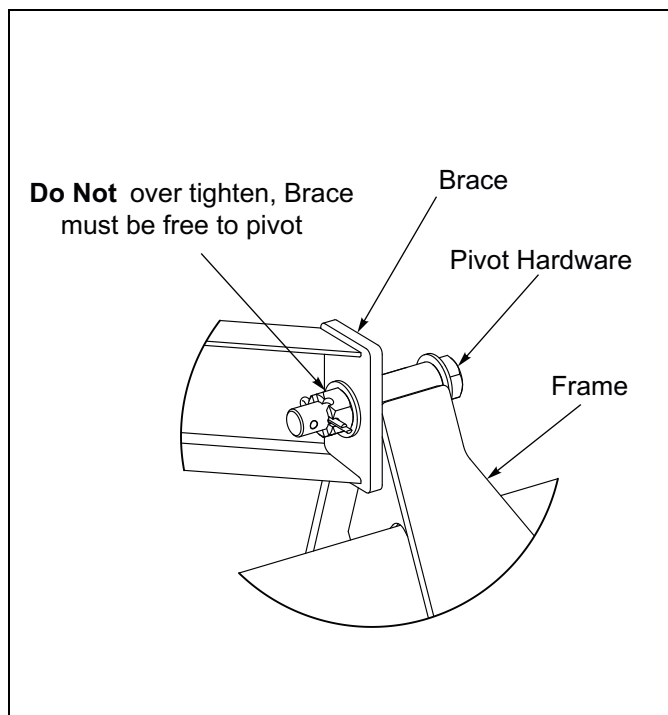

Figure 2-2: Frame Brace Lugs

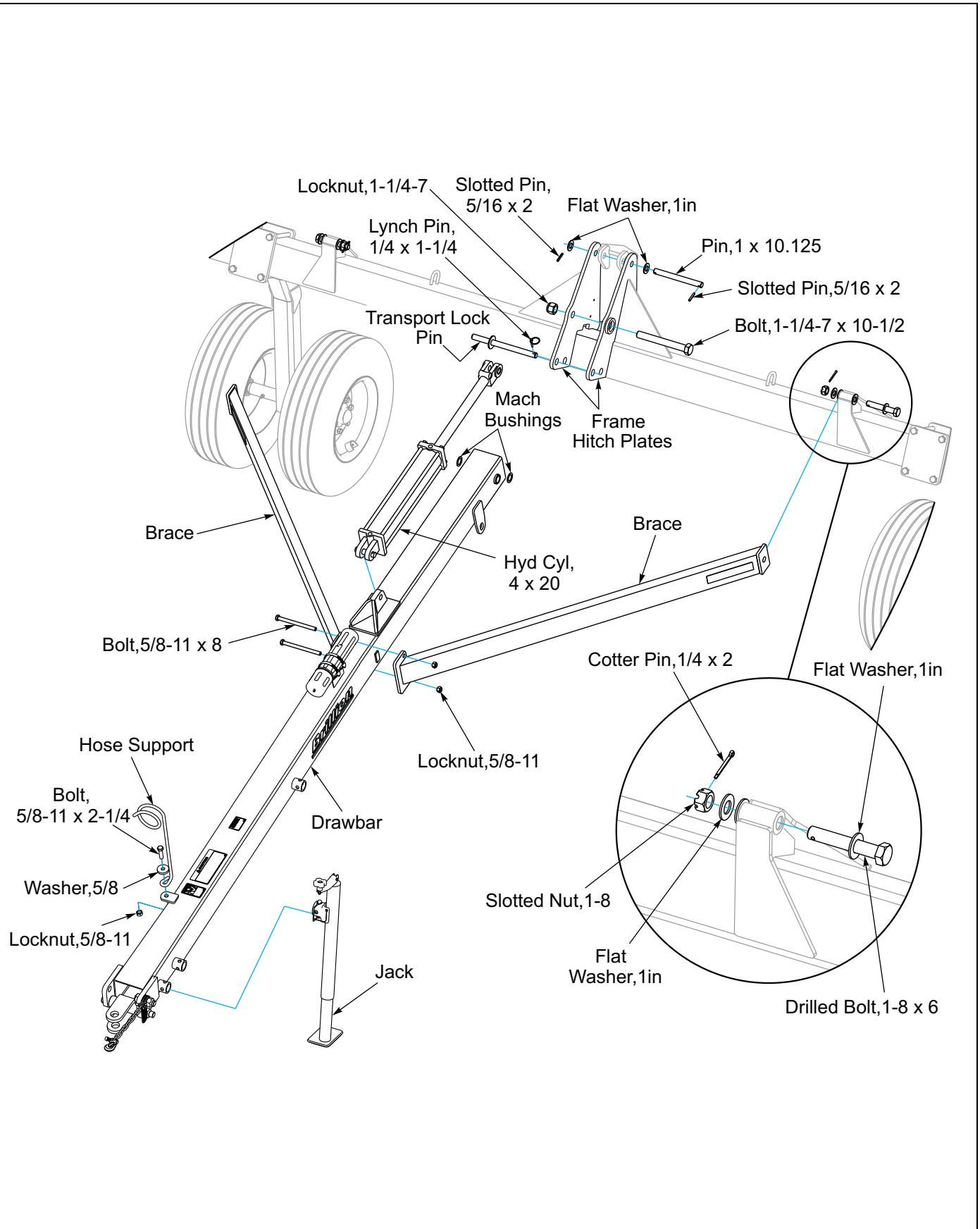

Figure 2-4: Drawbar

Bridge Hitch Coupler Installation

At the front of the Bridge Hitch slide the Bridge Hitch Coupler up into the Gooseneck tube, align the top hole and insert the Bent Pin, secure with Hair Pin Cotter. Thread a 3/4-10 Nut halfway onto each 3/4-10 x 2 Bolt. Screw them into the 3/4-10 welded nuts on the Gooseneck tube. Snug the Bolts up against the Bridge Hitch Coupler, turn the 3/4-10 Nuts so they are tight against the welded 3/4-10 Nuts. **See Figure 2-5.**

Attach the Safety Chain to the Bridge Hitch by sliding two 1 inch Washers into the slotted end of the chain, place a 1 inch Washers between the chain and the Bridge Hitch. Insert 1-8 x 9 Bolt through the chain, washers and hitch, secure with 1-8 Locknut.

Install the Double Stand into the rear of the Bridge Hitch by sliding it up into the stand tubes, secure with two 3/4 Pins with Chains.

Mount the Manual Storage Canister to the right side rear of the hitch using two Hose Clamps.

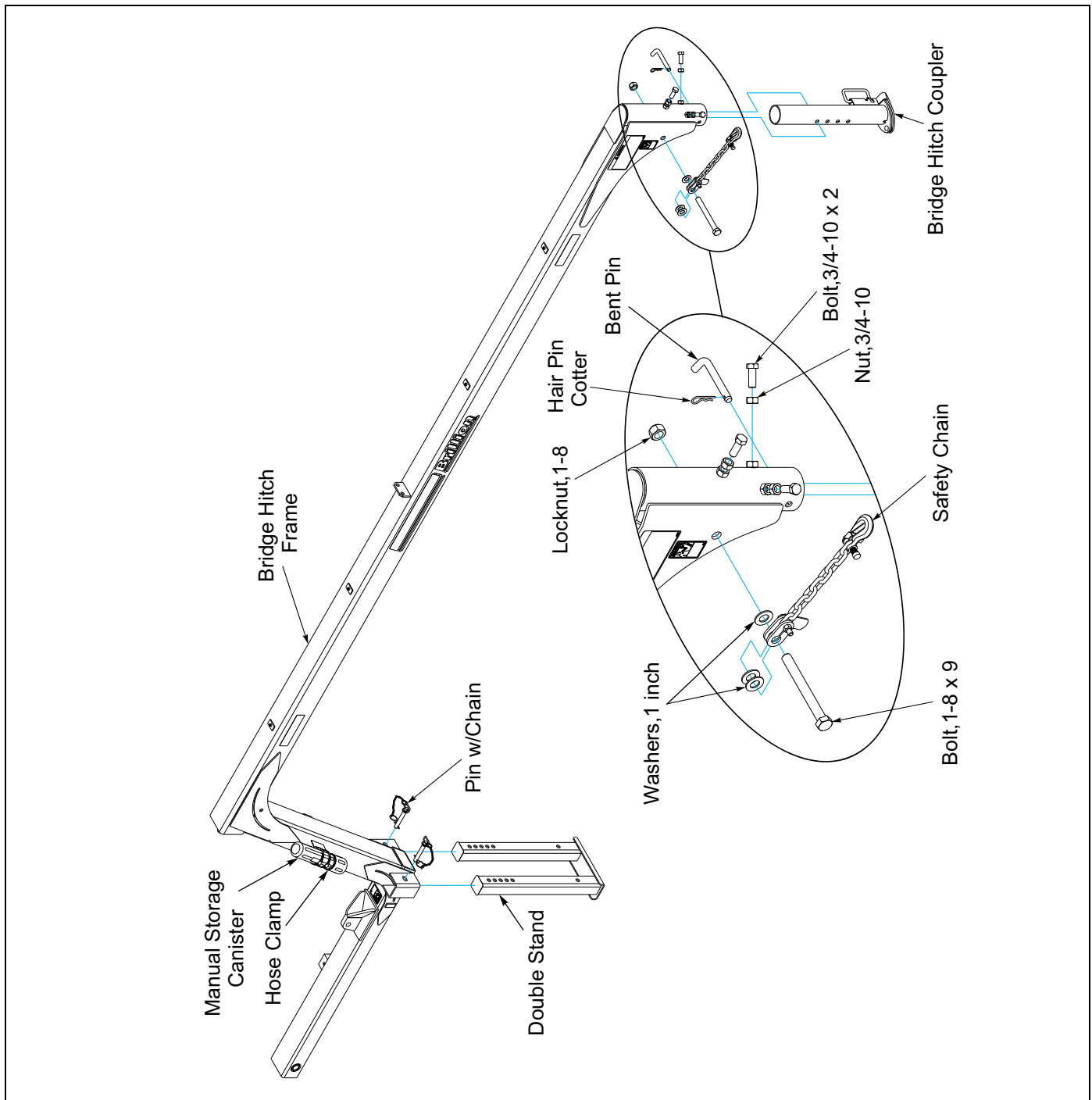

Figure 2-5: Bridge Hitch Coupler Installation

Bridge Hitch Installation

Bring the rear of the Bridge Hitch into position between the frame hitch plates at the center of the frame. Place a Thick Washer on each side between the Bridge Hitch and the Hitch Plates. Line up the holes and insert 1-1/4-7 x 10-1/2 Bolt, secure with Locknut. *The nut should be tightened so that the frame is free to pivot on the Bridge Hitch.*

Bridge Hitch Brace Installation

Attach the LH Hitch Brace to the outside of the Frame Brace Lug and a Bridge Hitch Brace to the inside of the Frame Brace Lug. **See Figure 2-6.** Slide Flat Washer onto 1-8 X 6 Drilled Bolt and insert bolt through LH Hitch Brace. Add another Flat Washer and slide Bolt through Frame Brace Lug and Bridge Hitch Brace. Add as many flat washers necessary so the Slotted Nut groove is aligned with the end hole.

The Slotted Nut should be tightened so that the Frame is free to pivot on the Bridge Hitch. Insert 1/4 X 2 Cotter Pin. Repeat for the Right Hand side.

Rotate the braces so they are against the Lower Bridge Hitch Tube, with one hole above and one hole below. Insert 5/8-11 x 8-1/2 Bolts through the holes in the braces secure with 5/8-11 Locknuts. *These locknuts should be tightened securely (110 Ft-Lbs)*

Rotate the Left and Right hand Hitch Braces so they are against the Upper Bridge Hitch Tube. The two holes above and two holes below. Insert on both sides a 1/2-13 x 1-1/2 Bolt into the Hitch Brace and into the Bridge Hitch Gusset, secure with Washers and Locknuts, do not tighten. Insert three 1/2-13 x 8-1/2 Bolts through the Hitch Braces, secure with Locknuts. Tighten all hardware at this time. **See “General Torque Specifications” on page 4-1.**

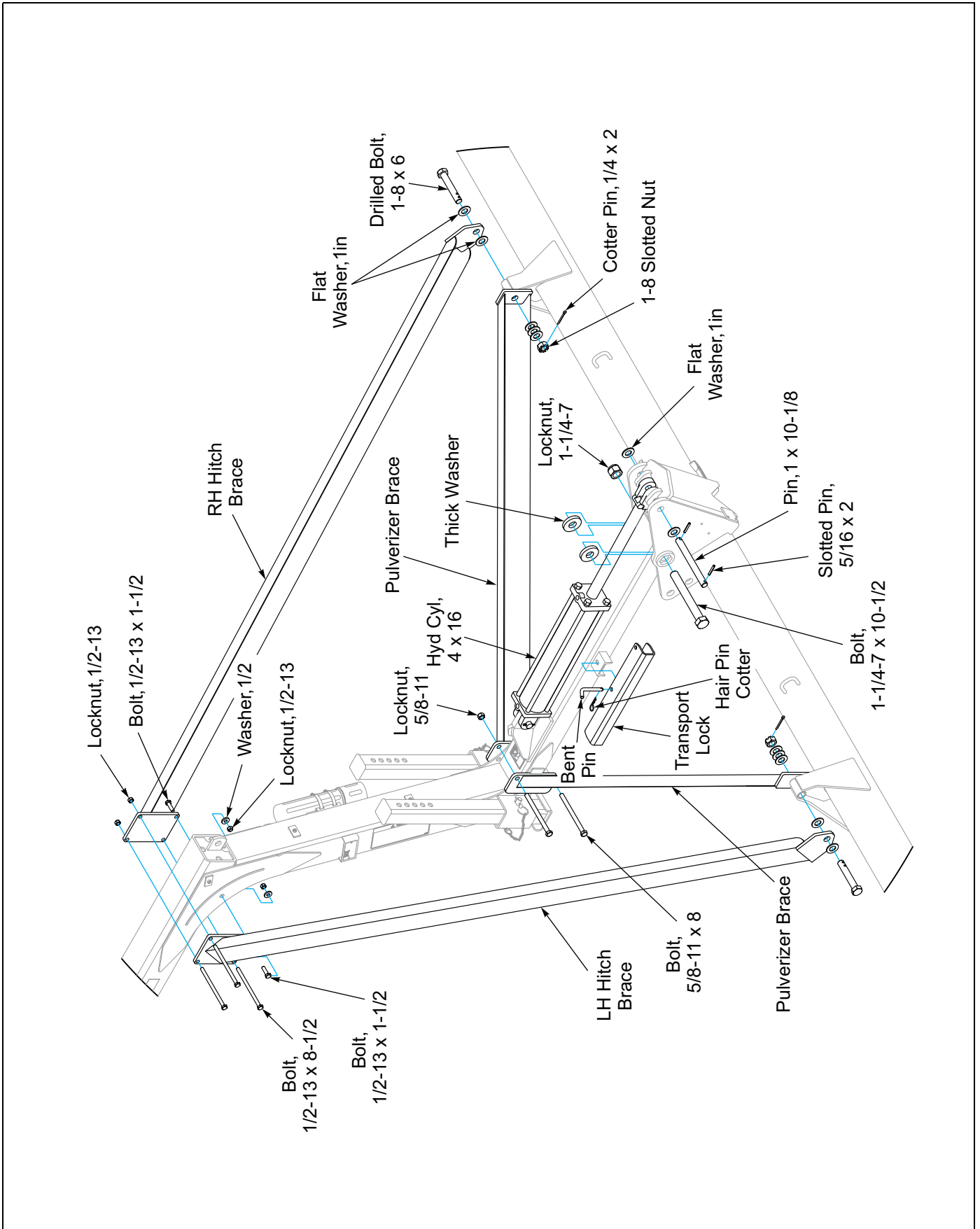

Figure 2-6: Bridge Hitch Braces

Wheel Arm Assembly

Attach the Wheel Arms to the Frame. The Wheel Arms should be equally spaced from the center of the machine.

See Figure 2-7. Fasten the Wheel Arms to the Frame with 4 Hole Plates and eight 3/4-10 x 9-1/2 Bolts and Locknuts. Insert the Hub and Spindle Assembly into the Wheel Arms. Lock spindle in place with the 3/8-16 x 3 Bolt, secure with Locknut. Attach Tire and Wheel to the Hub and Spindle with the 1/2-20 x 1 Wheel Bolts. **See Figure 2-8.**

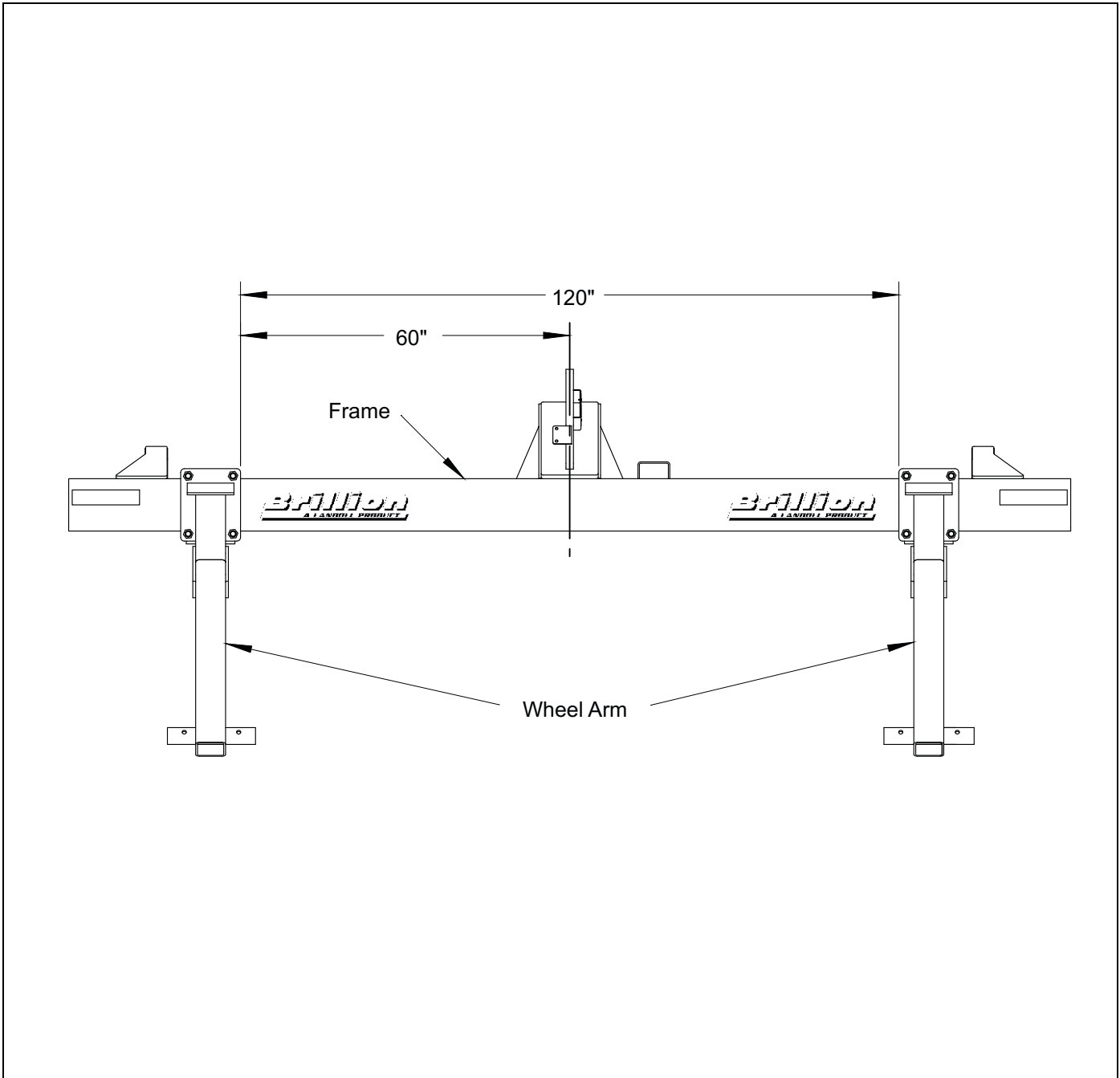

Figure 2-7: Wheel Arm Mounting Dimensions

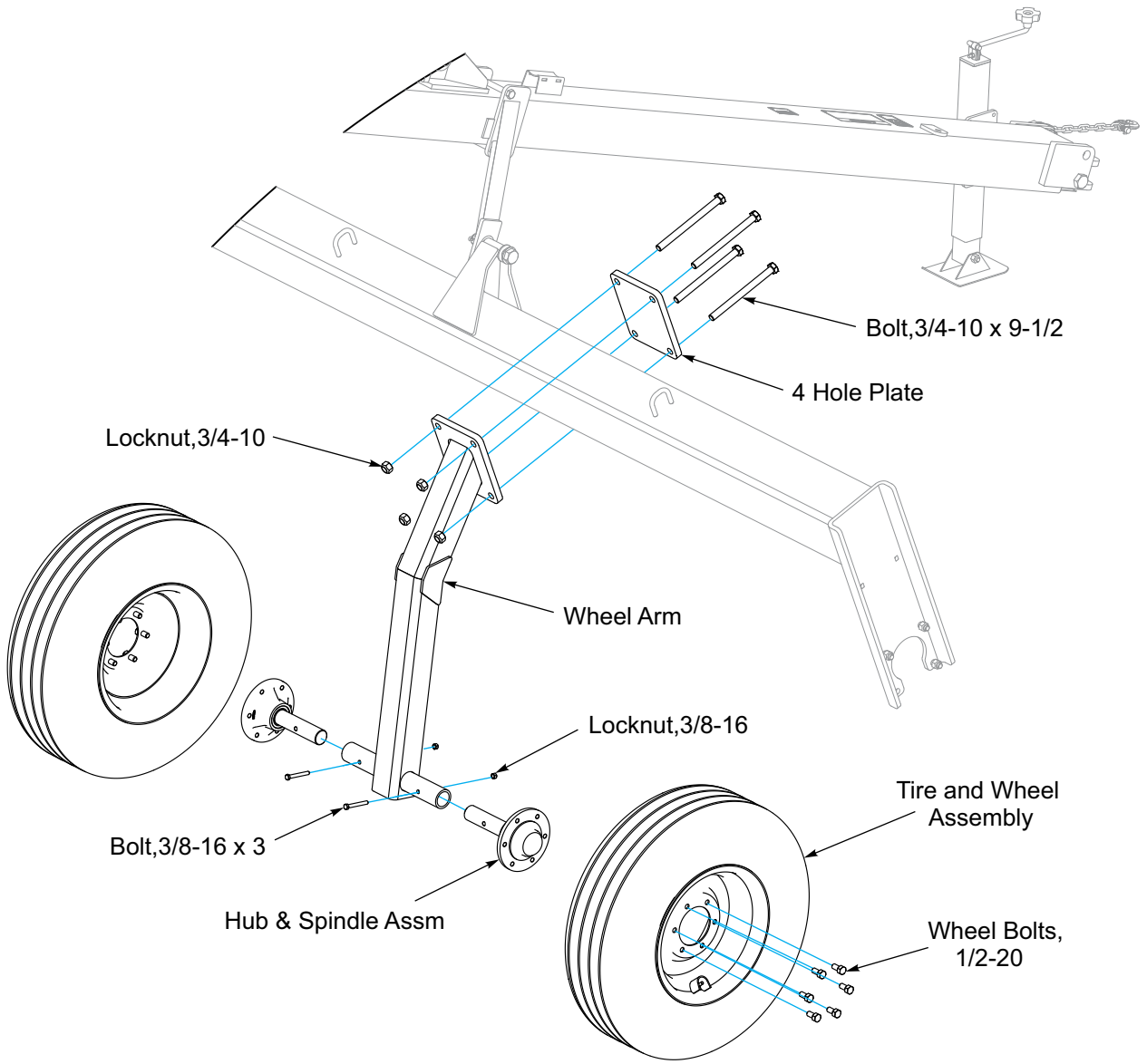

Figure 2-8: Wheel Arm Assembly

Hydraulic Circuit Installation



WARNING

Escaping fluid under pressure can be nearly invisible and have enough force to penetrate the skin causing serious injury. Use a piece of cardboard, rather than hands, to search for suspected leaks. Wear protective gloves & safety glasses or goggles when working with hydraulic systems.

Tightening Procedure For JIC 37° Swivel Female Nuts

1. Check flare and seat for defects.
2. Lubricate the connection.
3. Install hoses without twists.
4. Hand tighten until connection bottoms.
5. Using 2 wrenches to prevent twisting, rotate the swivel nut 2 wrench flats (1/3 turn).
6. For reassembly, follow the same procedure but tighten only 1 wrench flat (1/6 turn).

Tightening Procedure For Swivel O-Ring Fittings

1. Lubricate O-Ring and install the fitting until the metal washer which backs up the o-ring contacts the face of the boss.
2. Orient the fitting by turning counterclockwise up to 1 turn.
3. Tighten the lock nut using 50-60 foot pounds torque.

(See “Hydraulic Fitting Torque Specifications” on page 4-2.)



CAUTION

Do not raise the machine without the use of hydraulics. This would introduce air into the hydraulic cylinder. When the transport pin is removed the frame would lower rapidly possibly causing injury.

Remove Fitting Caps prior to installing Fittings.

Attach the hydraulic cylinder base end to the drawbar lug with vendor supplied hardware. Attach rod end to the frame lug with 1 x 10-1/8 pin. **See Figures 2-4 and 2-6.** Place a flat washer on each side and secure with 5/16 x 2 roll pin. It may be necessary to extend the cylinder rod or raise the frame slightly to make this connection. Be sure to bend the cotter pins so that the cylinder mounting pins cannot disengage.

Pulverizer with Drawbar Hydraulic Circuit Installation

Attach the Manual Storage Canister using two 4-1/2 Hose Clamps.

Screw a 1/16 Restrictor/90 degree elbow into each cylinder port. Connect 3/8 x 185 Hose Assembly to the Cylinder rod end Restrictor and 3/8 x 161 Hose Assembly to the Cylinder base end Restrictor. Route the two Hose Assemblies along the Drawbar and under the manual canister bracket through the Hose Support. Assemble Male ORB X Male JIC Adapter Fittings into Male Couplers and turn them into the end of the Hoses. **See Figure 2-9.**

Pulverizer with Bridge Hitch Hydraulic Circuit Installation

Screw a 1/16 Restrictor/90 degree elbow into the rod end port and a 90 degree Male ORB x Female Swivel JIC Elbow Fitting into the base end port of the Hydraulic Cylinder. Screw a Restrictor into the Ball Valve port that will connect up to the base end of the hydraulic cylinder and a Male ORB X Male JIC Adapter Fitting into the other port of the Ball Valve. Connect the Ball Valve Restrictor to the Elbow in the base end port of the Cylinder. Assemble Bulkhead Fittings into the bulkhead plate located on the top of the of the Bridge Hitch Tube. Connect 3/8 x 185 Hose Assembly to the cylinder rod end 1/16 Restrictor/90 degree elbow and 3/8 x 161 Hose Assembly to the Ball Valve Adapter Fitting. Route hose up the Bridge Hitch connecting them to the Bulkhead Fittings. Connect 3/8 x 150 Hose Assemblies to the bulkhead fittings and route them along the Bridge Hitch to the Gooseneck Coupler. Turn a 90 degree Male JIC x Female Swivel JIC Elbow Fittings into the end of the Hoses. Assemble Male ORB X Male JIC Adapter Fittings into Male Couplers and turn them into Elbow Fittings at the end of the Hoses.

Secure hoses with Twin Clamps, Top Plate and 5/16-18 1-1/4 Bolts in the mounts provided on the Bridge Hitch. **See Figure 2-10.**

(See “Hydraulic Fitting Torque Specifications” on page 4-2.)

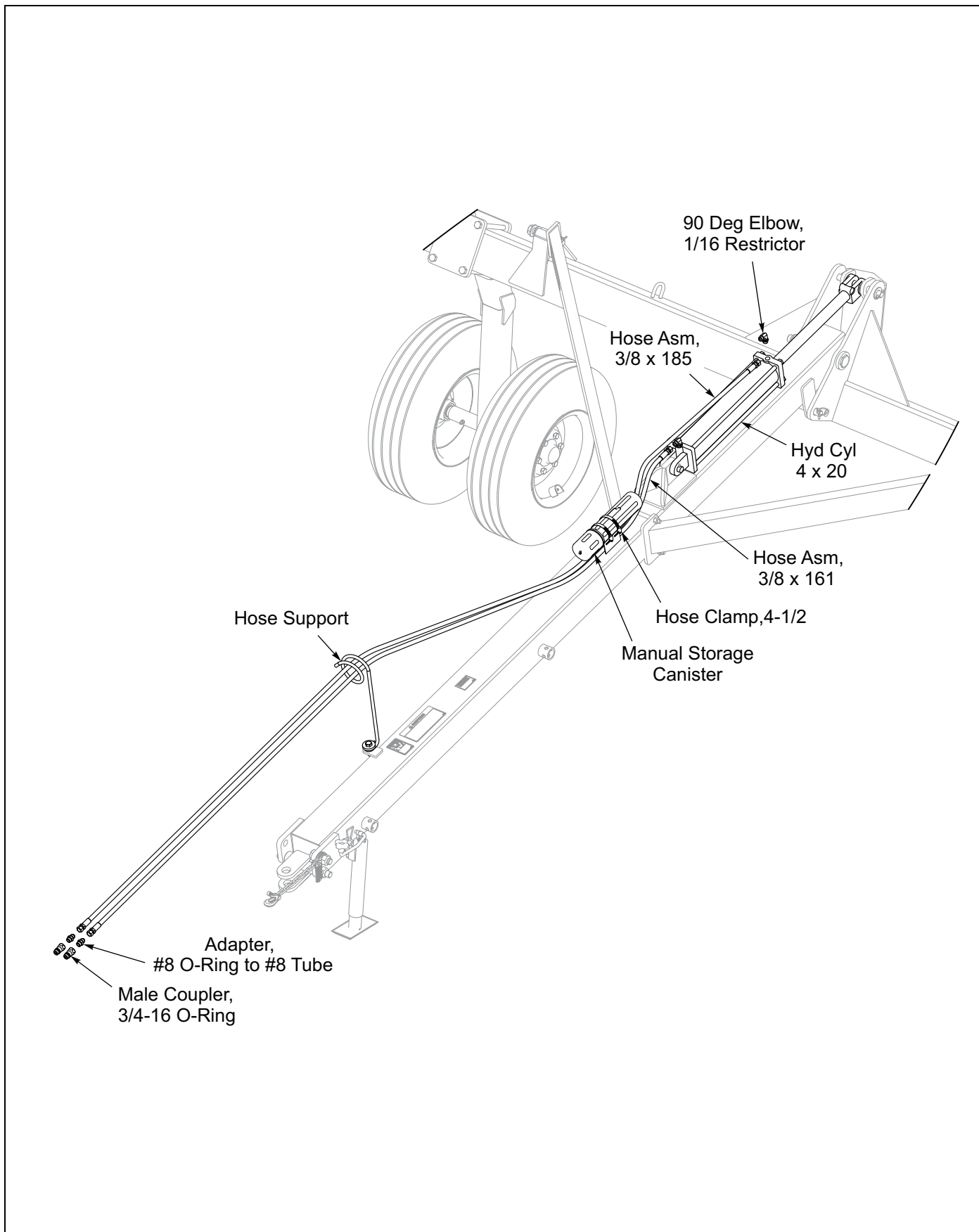

Figure 2-9: Hydraulic Hose Installation

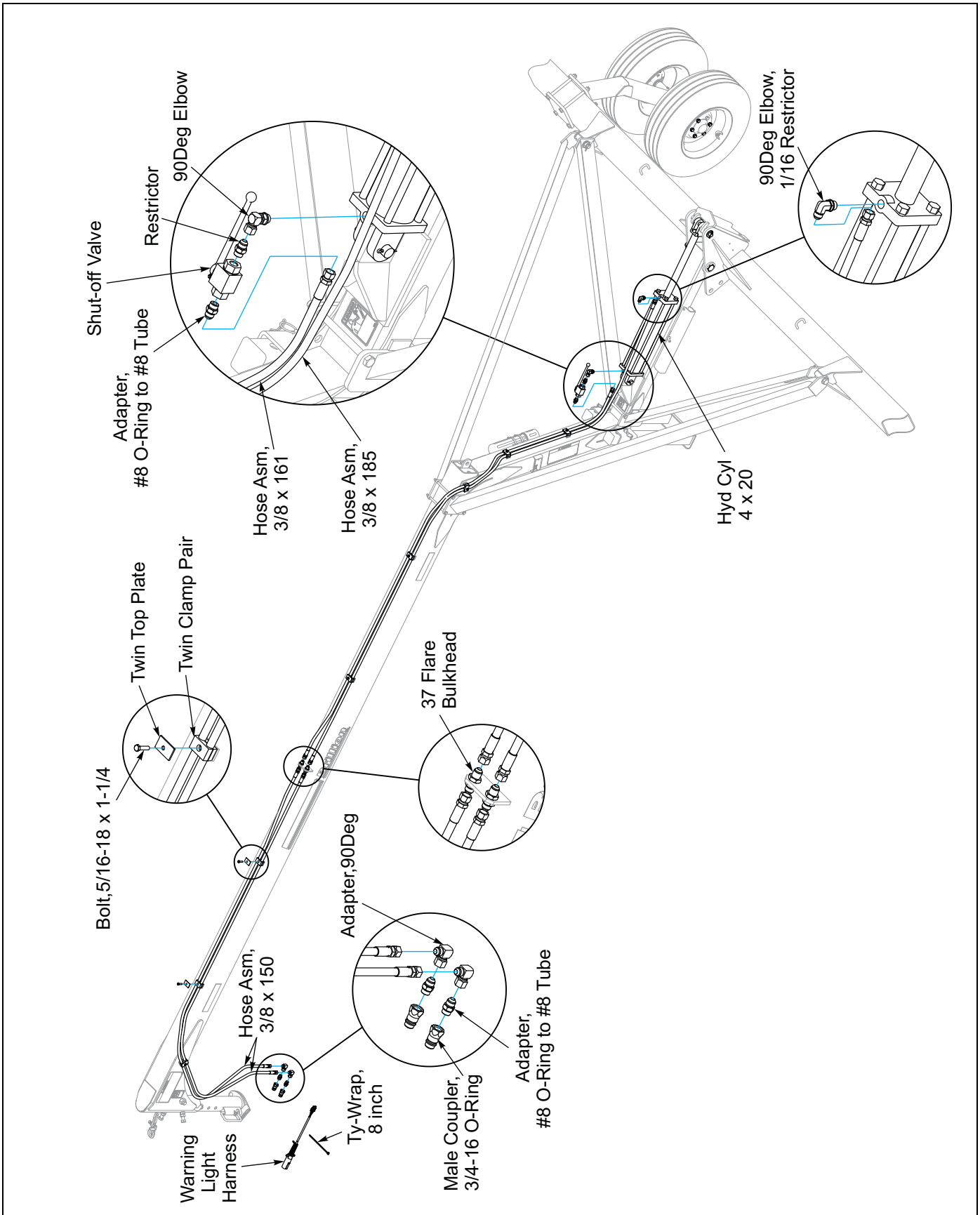

Figure 2-10: Optional - Bridge Hitch Hydraulics

LED Lights Installation

NOTE

20' and 22' models similar. See Figure 2-12.

1. Attach the four Light Brackets to the frame by placing the Strap under the frame and secure using 1/2-13 x 8-1/2 Bolts, Flat Washers and Flange Locknuts.
2. On the frame ends attach the Light Shield Tube to the Light Brackets by placing the Amber LED inside and inserting four 1/4-20 x 1-1/2 Bolts. Place the Decal Plate over the two front half bolts, then secure all four bolts using 1/4-20 Locknuts.
3. Attach the Red LED to the inside mounted Lights Brackets using four 1/4-20 x 1-1/2 Bolts, place the Decal Plate over the two front side bolts and secure all four bolts using 1/4-20 Locknuts.
4. Attach the Flasher Control Module to the Module Bracket located near the center of the frame using two 1/4-20 x 2 Bolts and Locknuts.
5. Lay out the Lamp Harness, noting that the connectors marked with Green Tape is Right Side and Yellow Tape is Left Side.
6. Plug the Lamp Harness into the Flasher Control Module, route both cord plugs with Green Tape along the top of rear frame. Route the plugs up through the Light Bracket and plug the 3 prong cord into the Red LED. Plug the 2 prong cord into the Amber LED.
7. Repeat for the Left Side (Yellow Tape).
8. Plug the 7 Pin Harness into the Flasher Control Module, then route the harness along the Drawbar with hoses and secure with Tie Straps. If optional Bridge Hitch is used a longer 7 Pin Harness is used.
9. Adjust the LED lamp angles so LED's are vertical with the drawbar height adjusted to the transport height. Adjustment is provided to compensate for high drawbar heights if used as a companion tool or lower heights if towed directly behind a tractor. See Figure 2-11.
10. Tighten all hardware.
11. Bundle and secure excess cord to the Light Bracket with Tie Straps. Secure cords along frame using Tie Straps.

Pulverizer with Bridge Hitch LED Lights Installation

When using the Bridge Hitch an additional 33ft 7 Pin AG Harness connector is required. Route this harness up the Bridge Hitch Frame along the hydraulic hoses. Secure cords along frame using Tie Straps.

NOTE

All wires must be firmly attached to machine frame members so they do not sag or become torn loose by field debris.

12. Attach the SMV Sign to the center frame weldment using two 5/16-18 x 1 Bolts, Flat Washers and Locknuts.
13. Apply the reflector decals to Decal Plate Mounts. The amber reflector decals should be front facing on the outer Decal Plate Mounts. The red reflector decals and orange decals should be rear facing on both the inner and outer decal plate mounts.

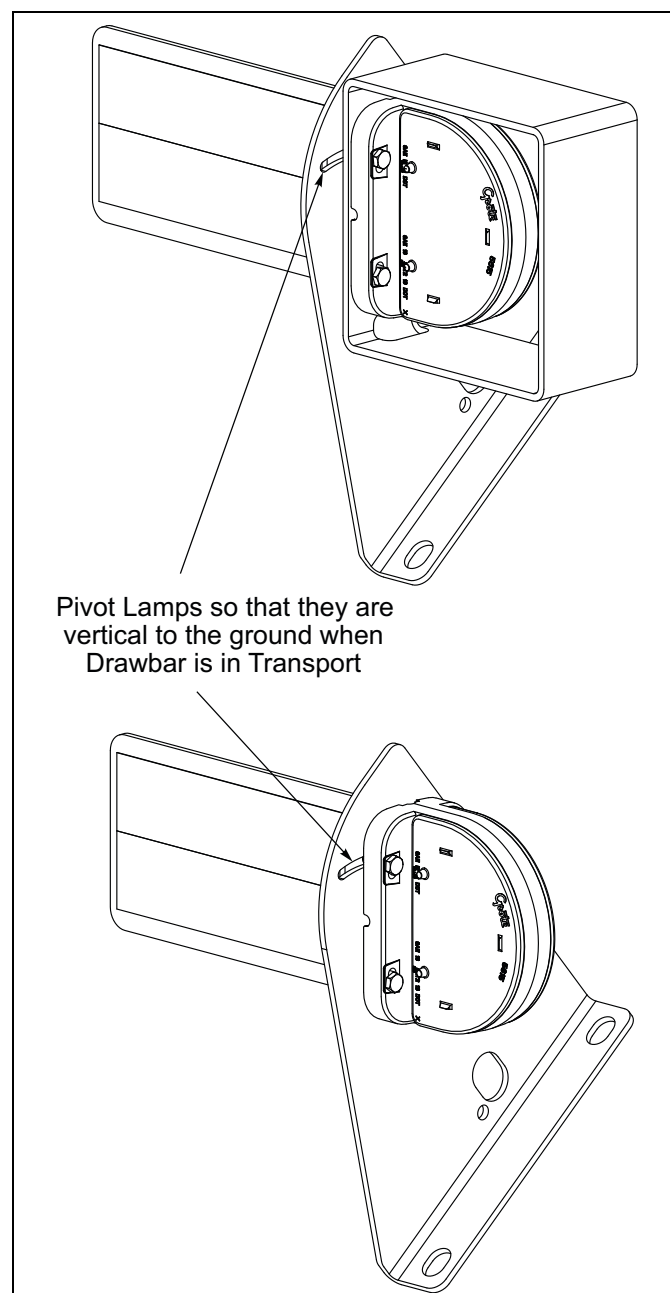

Figure 2-11: LED Lamp Adjustment

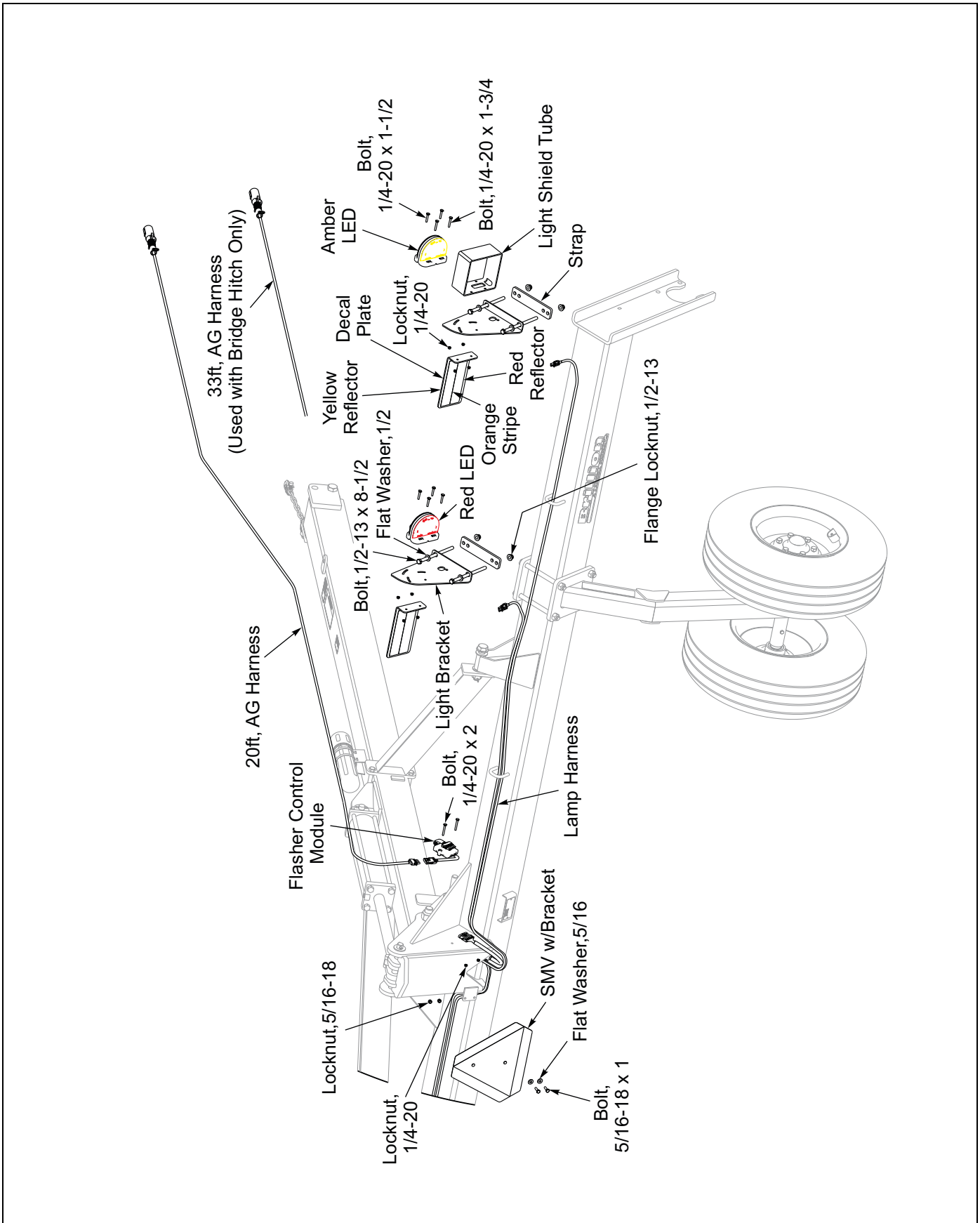

Figure 2-12: LED Light Installation

Chapter 3

Operation

NOTE

This chapter will cover the basic operation and procedures for the Landoll Brillion Floating Ring Pulverizer. Be sure to read and understand the Safety Procedures and Cautions starting on page 1-2.

Before operating your machine check all hardware for tightness. Use the Torque Tightening Chart as a guide. **See page 4-1.**



WARNING

Escaping hydraulic fluid can cause serious personal injury. Relieve system pressure before repairing, adjusting, or disconnecting. Wear proper hand and eye protection when searching for leaks. Use cardboard instead of hands. Keep all components (cylinders, hoses, fittings, etc.) in good repair

NOTE

Prevent wheel breakage by reducing speed when operating in rocky conditions.



WARNING

Maximum road speed is 20 MPH under good conditions. Do not tow the machine at a speed which makes vehicle control difficult.

If the weight of the towing vehicle is:

*equal to or greater than the equipment being towed, **MAXIMUM** road speed is 20 MPH.*

*less than the weight of the equipment but greater than half the weight of the equipment being towed, **MAXIMUM** road speed is 10 MPH.*

*less than half the weight of the equipment to be towed, **DO NOT TOW.***



CAUTION

Do not stand between the two pieces of equipment when attaching to the drawbar unless they are not moving.

NOTE

During field operations, it is not necessary to raise the machine for turns, but turns should be made as wide as possible.

The PFT Pulverizer is designed to be pulled behind tractors, seeders, or tillage tools. The long drawbar allows for easy turns when pulled behind other equipment.

When attaching the pulverizer to a tractor or implement whose drawbar height is less than 30 inches, locate the drawbar jack on the jack swivel mount closest to the front of the drawbar. **See Figure 3-1.**

If you need to attach your pulverizer to a drawbar which is higher than 30" such as a Brillion Land Commander, use the 2nd and 3rd jack swivel mount near the center of the drawbar. **See Figure 3-2.**

Drawbar Jack Positions

DRAWBAR JACK POSITION

DRAWBAR JACK MOUNTED ON 1ST JACK SWIVEL

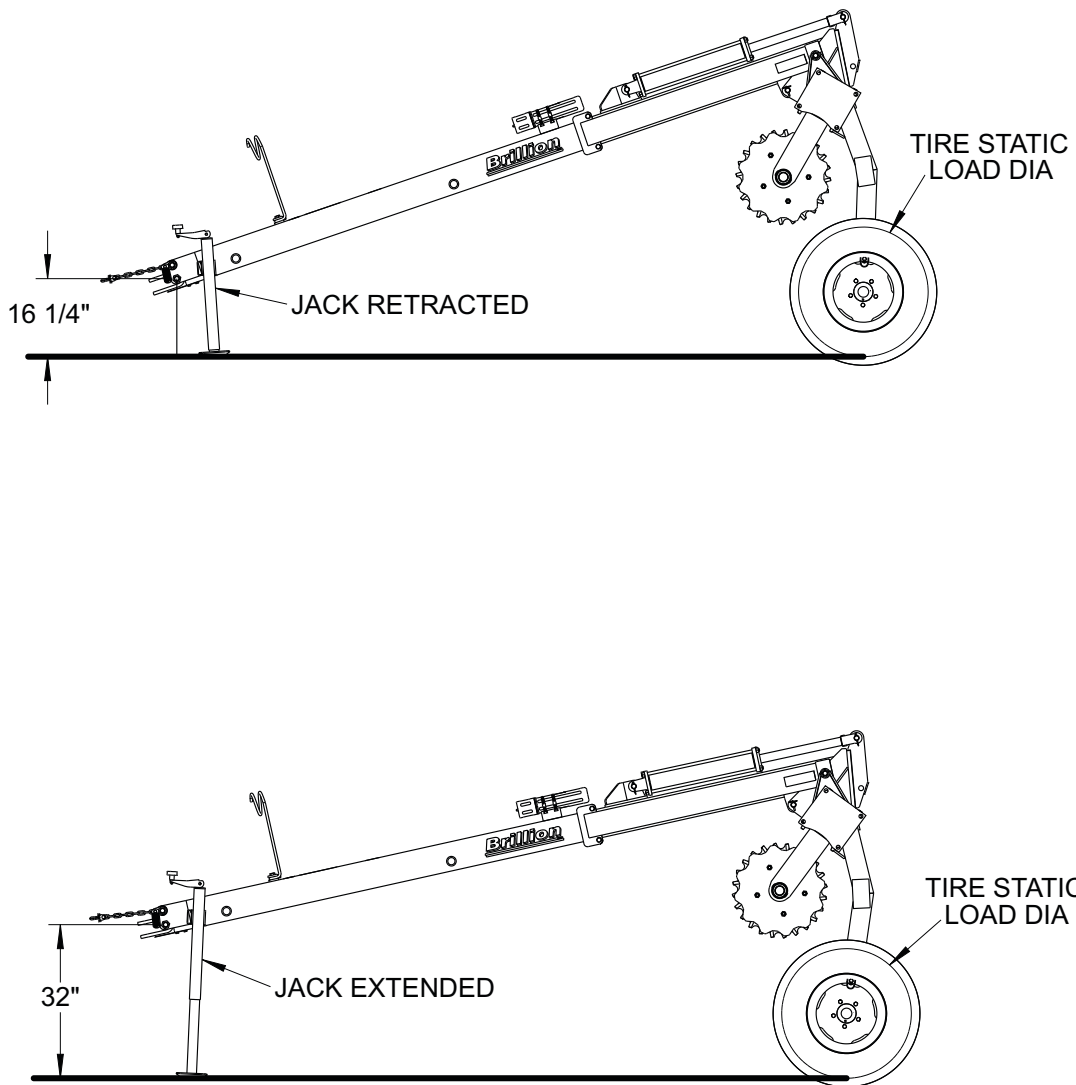
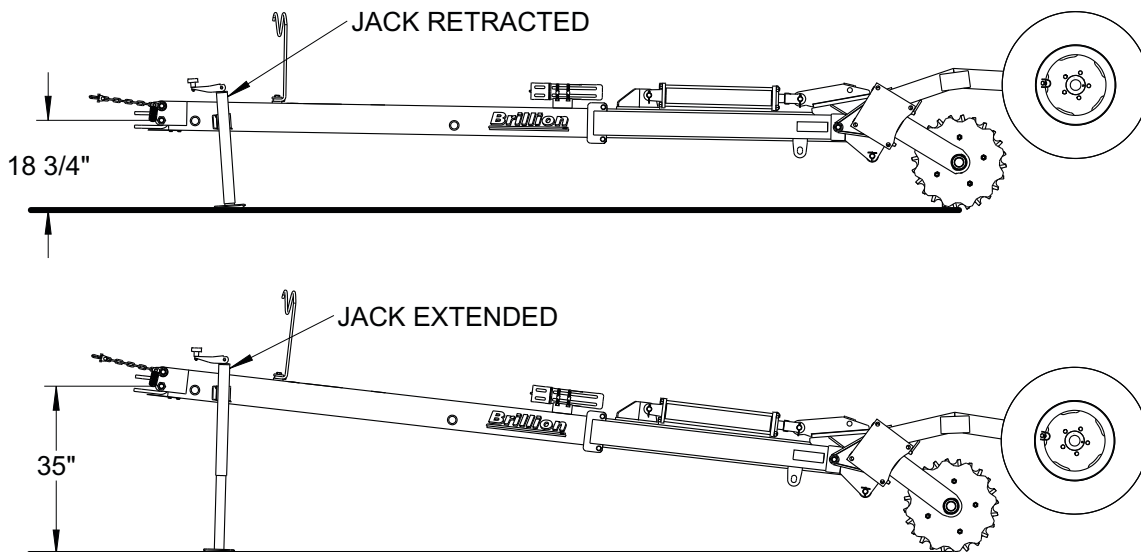

Figure 3-1: 1st Jack Swivel Position

DRAWBAR JACK POSITION

DRAWBAR JACK MOUNTED ON 2ND JACK SWIVEL



DRAWBAR JACK MOUNTED ON 3RD JACK SWIVEL

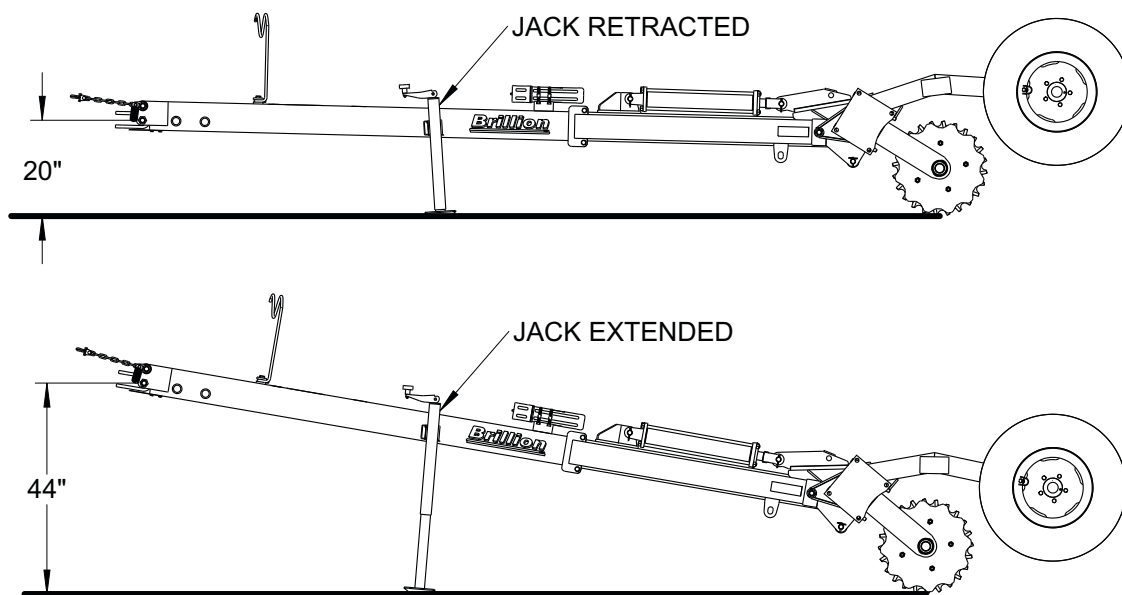

Figure 3-2: 2nd and 3rd Jack Swivel Positions

Parking

The safest way to park your pulverizer is to lower it into the operating position, place blocks behind and in front of the pulverizer wheels, then use the jack to take the weight off the towing implement and unhitch the machine.

Attaching to Equipment

To attach it to equipment, reverse the above procedure. When attaching to a piece of equipment with a high drawbar, back the equipment near the pulverizer with the hitches in line, then lower the towing implement as much as you can while still being able to move it, raise the pulverizer drawbar to the desired height, bring the towing equipment into the final location, attach the pulverizer to the other machine. Then return both pieces of equipment to their transport position and install Transport Lock Pin. **See Figures 3-4 and 3-5.**

Hitching the Bridge Hitch

Proper hitching to the towing implement requires a hitch built to safely tow the Bridge Hitch on the road and in the field. A 2-5/16 Hitch Ball is required.

The unhitched Bridge Hitch and Pulverizer should have the parking stand and roller on the ground. The wheels and hydraulic lift will be used to control the gooseneck couple. Back the towing implement under the gooseneck coupler, hook-up the hydraulic hoses. It may be necessary to raise the gooseneck couple by actuating the hydraulic circuit. Use caution and slowly adjust gooseneck couple height to allow for positioning over ball hitch. Lower gooseneck couple onto ball. Latch gooseneck couple, attach safety chain, connect warning lamp harness plug. If machine is to be transported on a roadway install transport locks. **See Figure 3-5.**

Unhitching/Parking Pulverizer with Bridge Hitch

NOTE

Be sure ground is level.

To prepare for unhitching, the towing implement needs to be in Transport position with transport locks installed. Lower Parking Stand by removing two hitch pins and repositioning stand to a parking position. Use caution the parking stand weighs approximately 50lbs. **See Figure 3-3.**

Uncouple gooseneck hitch and AG harness if equipped. Slowly lower pulverizer until parking stand makes contact with ground. At this point weight on gooseneck coupler will be transferred to parking stand. Continue to lower until there is enough clearance between ball and coupler. Close ball valve to lock cylinder in position.

Uncouple Safety Chain and Hydraulic Hoses from towing implement. Pull towing implement ahead, ensuring pulverizer has clearance and harness, hoses and safety chain do not become tangle

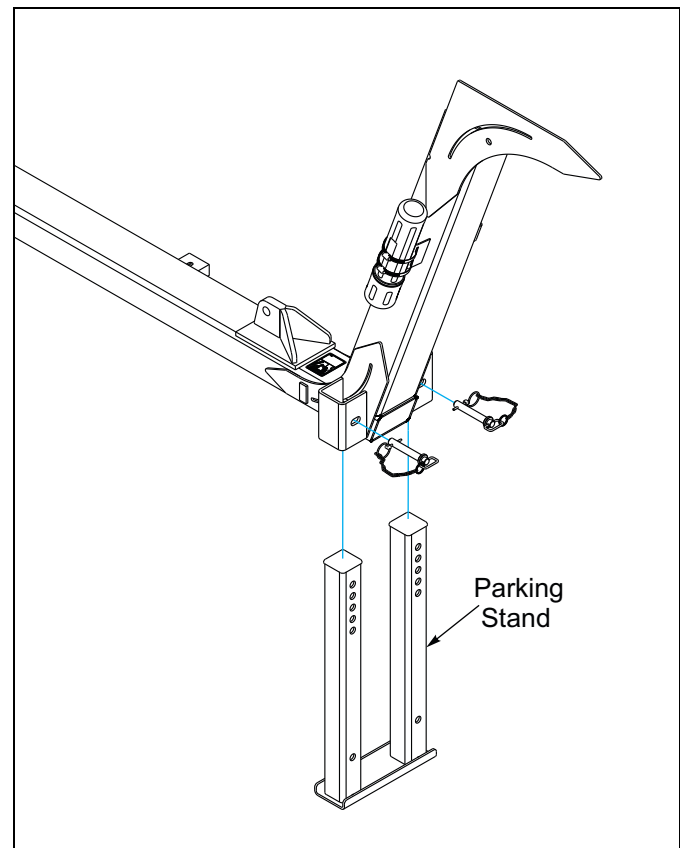

Figure 3-3: Parking Stand

Transport Lock



CAUTION

Be sure to install the transport lock pin any time the pulverizer is being pulled or stored in the transport position.

If you must store the pulverizer in the transport position, block the transport wheels, use the jack to relieve weight from the towing equipment, unhitch the pulverizer, and lower the jack to make it more stable. **Figure 3-4.** shows how and where to install the transport lock pin, and also shows the storage location for the pin when it is not being used.

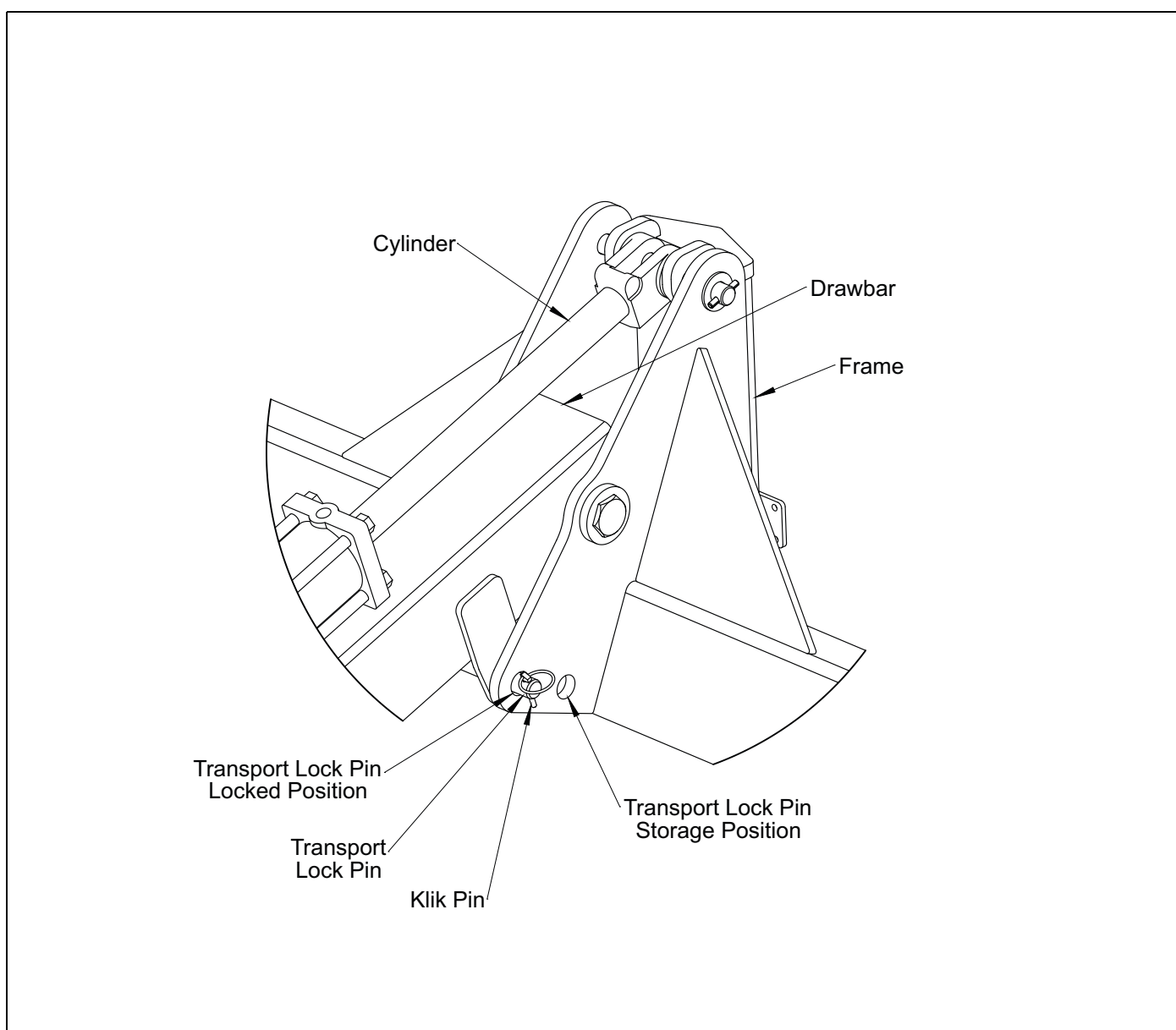

Figure 3-4: Transport Lock

Bridge Hitch Transport Lock

To prepare the machine for transport, raise it fully and place the Transport Lock over the Transport Axle Cylinder Rod. Insert the Bent Pin and secure with Hair Pin. When not in use store the Transport Lock on the storage channel and secure with Bent Pin and Hair Pin. See **Figure 3-5**.

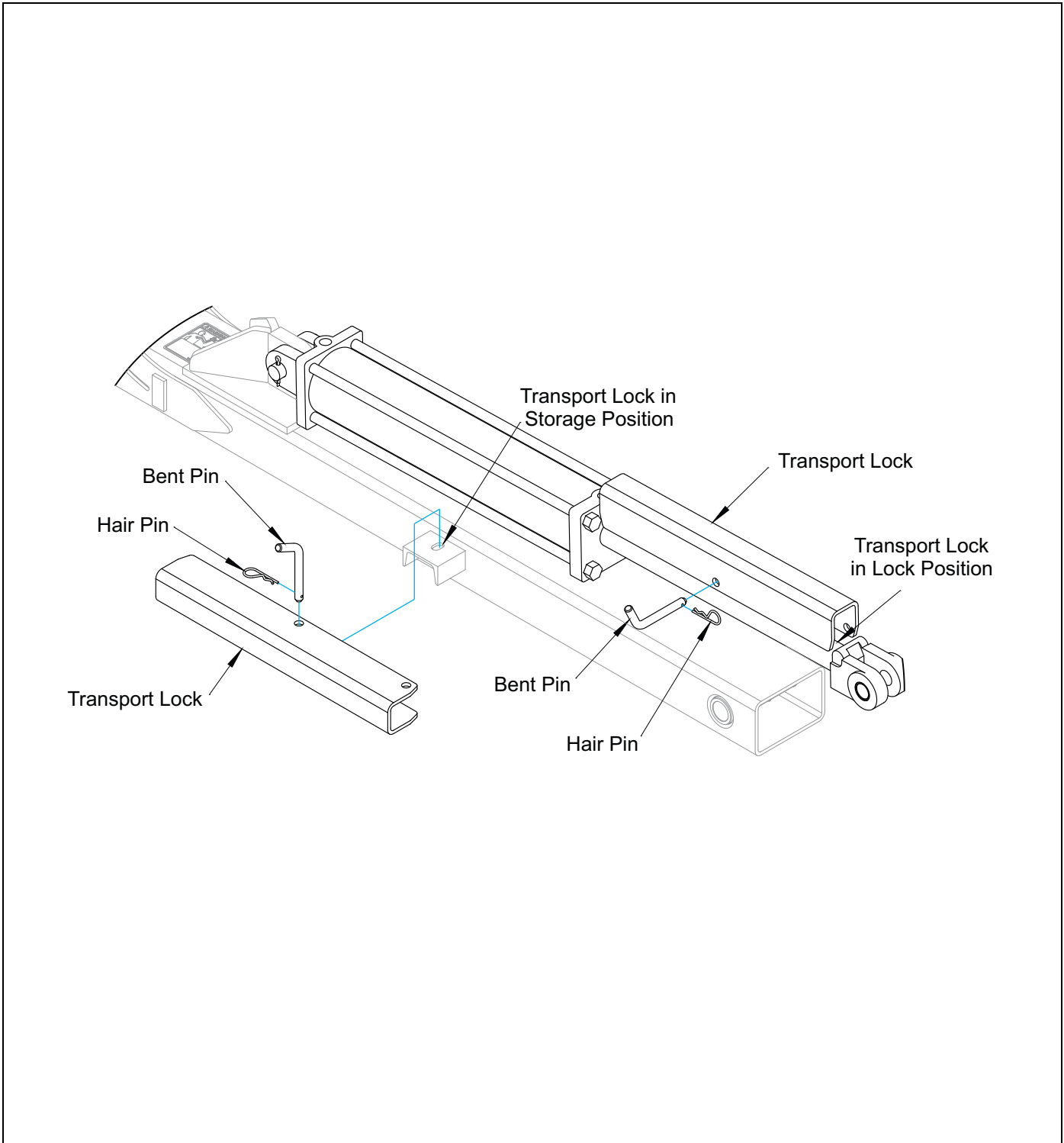

Figure 3-5: Bridge Hitch Transport Lock

Field Operations

The floating ring pulverizer is designed with rings whose inside diameter is greater than the drum which supports them. This allows the roller wheels to follow the irregular contours in your fields.

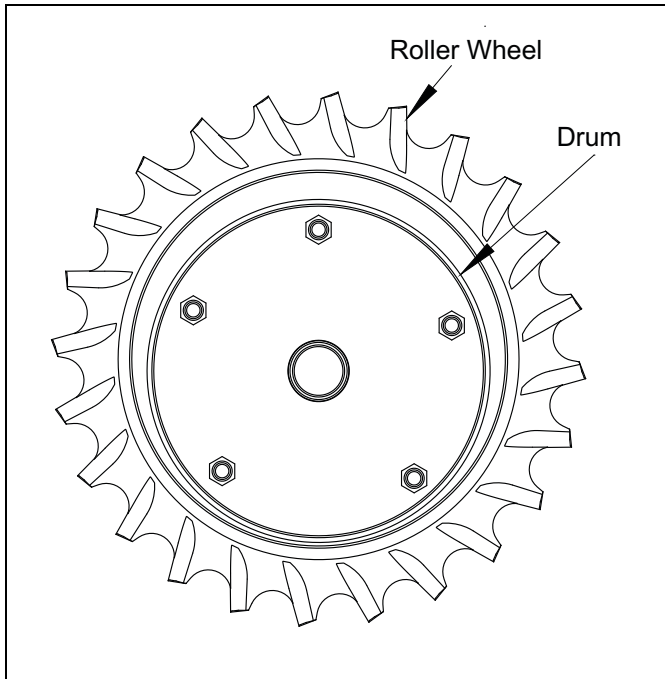

Figure 3-6: Floating Rings

Roller Orientation

The drum assembly can be mounted to the frame in two ways. When mounted as shown the wheels will have a tendency to pack the soil. **See Figure 3-7.** When the wheels are reversed they will act more like a rotary hoe and will have a tendency to loosen the soil. **See Figure 3-8.** To change the mounting of the wheel and drum assembly to the frame, follow these steps:

1. Lower the wheels to the ground.
2. Support the frame with an overhead hoist.
3. Remove the 5/8-11 x 1-3/4 Bolts and Locknuts which hold the Flange Bearings to the Bearing Hangers.
4. Raise the frame above the roller assembly.
5. Pivot the roller assembly 180 degrees
6. Re-attach the Flange Bearings to the frame using 5/8-11 x 1-3/4 Bolts and Locknuts.

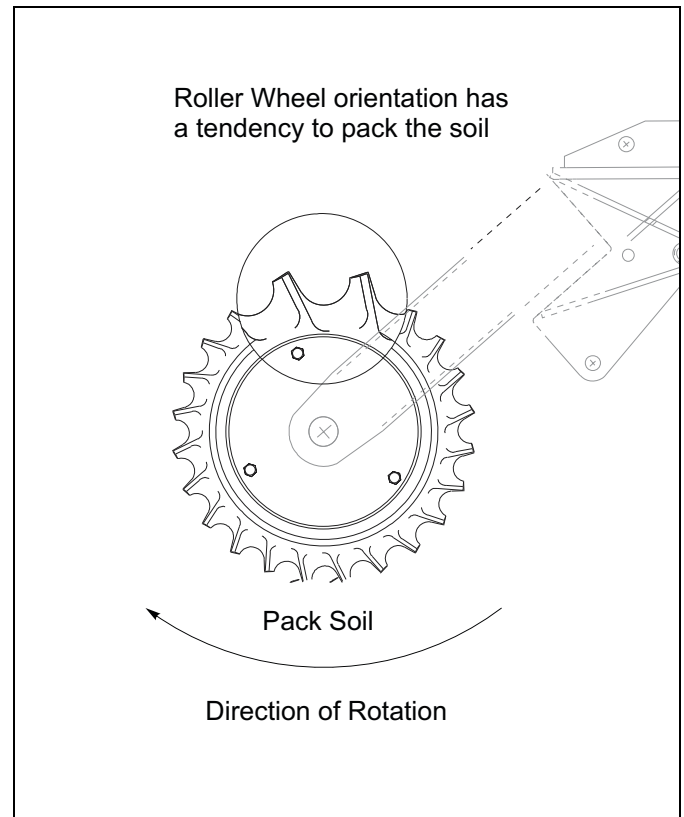

Figure 3-7: Pack Soil

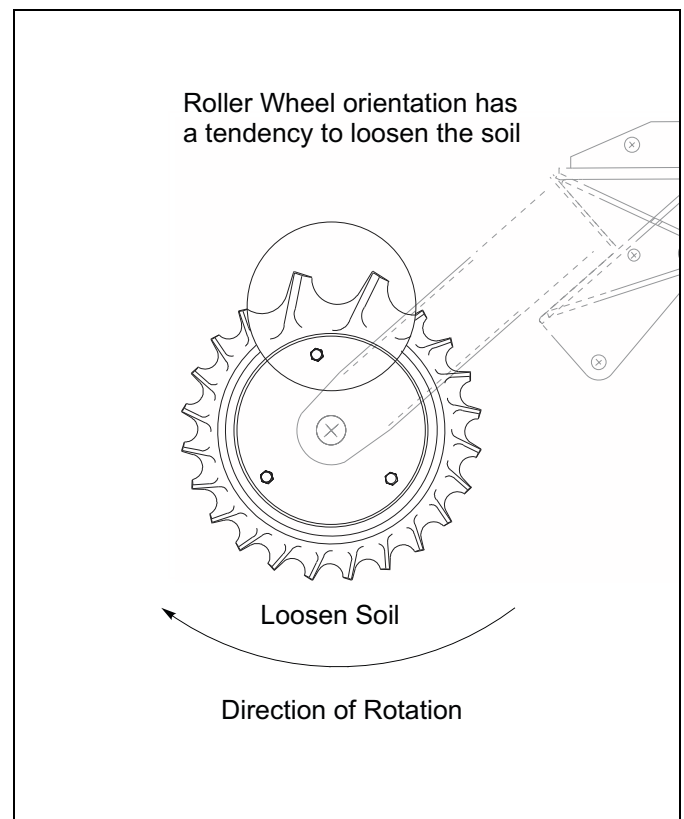

Figure 3-8: Loosen Soil

Transport

1. Check and follow all federal, state, and local requirements before transporting the Pulverizer.
2. The Pulverizer should be transported only by tractor required for field operation. The implement weight should not exceed more than 1.5 times the tractor weight. Maximum transport speed for the Pulverizer is 20 mph for the implement.



CAUTION

Excessive speed may result in loss of control of the tractor and implement, reduced braking ability, or failure of the implement tire or structure. Do not exceed the implement maximum specified ground speed regardless of the capability of the maximum tractor speed.

3. When towing equipment in combination, the maximum equipment ground speed shall be limited to the lowest specified ground speed of any of the towed implements.
4. Maximum transport speed shall be the lesser of travel speed specified in the operator's manual, speed identification symbol, information sign of towed equipment, or limit of road conditions.
5. Slow down when driving on rough roads. Reduce speed when turning, or on curves and slopes to avoid tipping. Equipment altered other than the place of manufacture may reduce the maximum transport speed. Additional weight, added tanks, harrowing attachments, etc. may reduce implement load carrying capabilities.
6. A safety chain is provided with the implement to insure safe transport.
 - The safety chain should have a tensile strength equal to or greater than the gross weight of the implement. The chain is attached to the lower hitch clevis hole with two flat washers between the clamp plates to assure a tight connection. Always use a 1" diameter Grade 8 bolt for this connection.
 - Attach the safety chain to the tractor drawbar (**See Figure 1-2.**) Provide only enough slack in the chain for turning. Do not use an intermediate chain support as the attaching point for the chain on the tractor. Do not pull the implement by the safety chain.

Regularly inspect the safety chain for worn, stretched, or broken links and ends. Replace the safety chain if it is damaged or deformed in any way.

7. Check that tires are of proper size, load rating, and inflated to manufacture specifications before transporting. Check wheel lug bolts to ensure tightness.
8. Know the transport heights and widths of the unit before transporting. Use caution when transporting near bridges and power lines.



WARNING

Electrocution can occur without direct contact

9. Raise the machine to full transport height.
10. Transport during daylight hours when ever possible. Always use flashing warning lights, except where such use is prohibited by law. Make sure lights, reflectors and SMV emblem are clearly visible and operating. remove any obstructions such as dirt, mud, stalks or residue that restricts view before transporting.
11. Reflectors and a slow moving vehicle sign (SMV) are required if the Floating Ring Pulverizer is transported on a public road. Check with local laws/ordinances.

NOTICE

When Transporting on Roadways, Obey all Applicable Laws and Regulations.

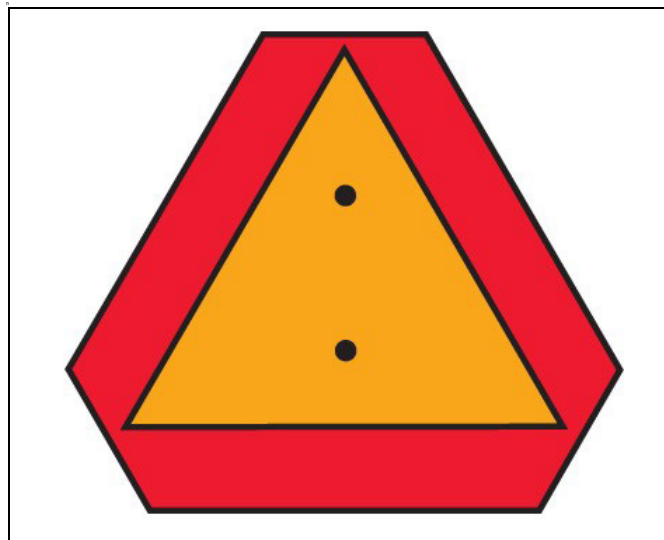

Figure 3-9: SMV Sign

LED 7-Pin AG Connector

- Make sure the tractor has a good clean receptacle, free of dirt and corrosion.
- Make sure the 7-pin connector is inserted ALL the way in. With tighter fitting pins, operator may think the connector is all the way in, but really isn't.

Ensure the tractor receptacle cover latches over the keyway on the 7-pin connector to hold the connector in place.

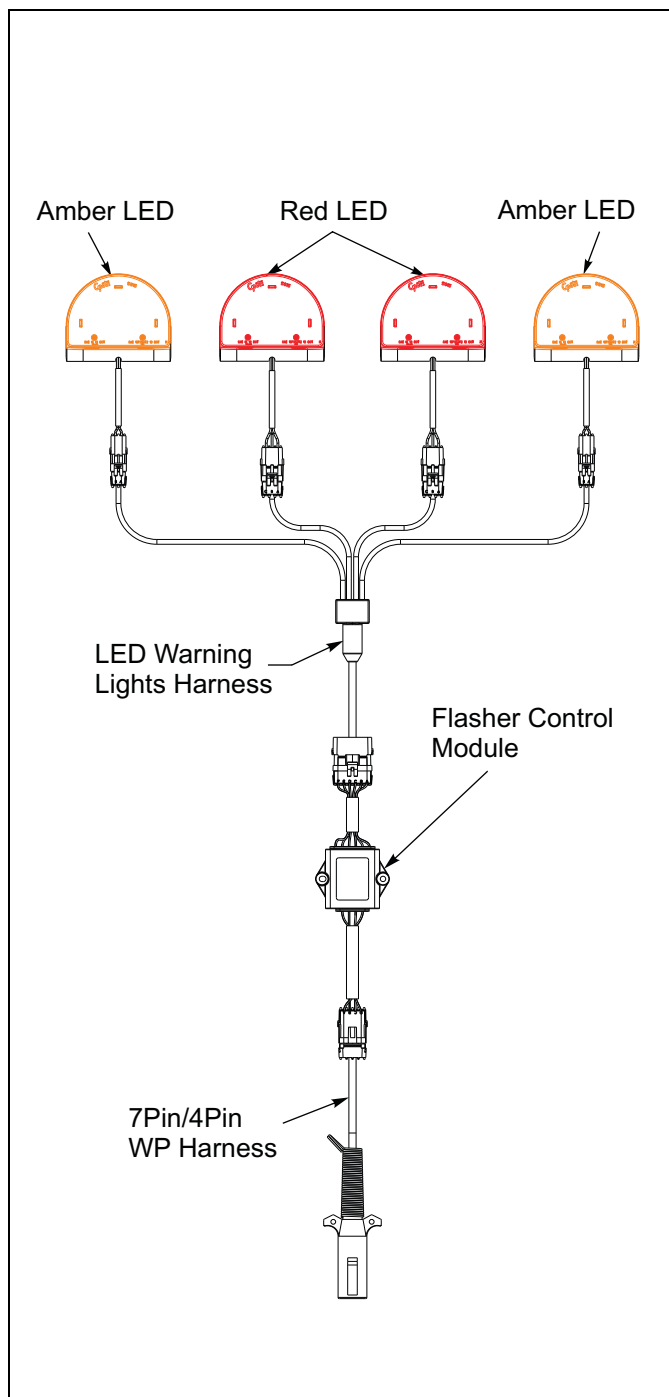

Figure 3-10: 7 Pin AG Connector

Maintenance

General Torque Specifications

(rev. 4/97)

This chart provides tightening torques for general purpose applications when special torques are not specified on process or drawing. Assembly torques apply to plated nuts and capscrews assembled without supplemental lubrication (as received condition). They do not apply if special graphite moly-disulfide or other extreme pressure lubricants are used. When fasteners are dry (solvent cleaned) add 33% to as received condition torque. Bolt head identification marks indicate grade and may vary from manufacturer to manufacturer. Thick nuts must be used on grade 8 capscrews. Use value in [] if using prevailing torque nuts

TORQUE SPECIFIED IN FOOT POUNDS

UNC SIZE	SAE Grade 2	SAE Grade 5	SAE Grade 8	UNF SIZE	SAE Grade 2	SAE Grade 5	SAE Grade 8
1/4-20	4 [5]	6 [7]	9 [11]	1/4-28	5 [6]	7 [9]	10 [12]
5/16-18	8 [10]	13 [13]	18 [22]	5/16-24	9 [11]	14 [17]	20 [25]
3/8-16	15 [19]	23 [29]	35 [42]	3/8-24	17 [21]	25 [31]	35 [44]
7/16-14	24 [30]	35 [43]	55 [62]	7/16-20	27 [34]	40 [50]	60 [75]
1/2-13	35 [43]	55 [62]	80 [100]	1/2-20	40 [50]	65 [81]	90 [112]
9/16-12	55 [62]	80 [100]	110 [137]	9/16-18	60 [75]	90 [112]	130 [162]
5/8-11	75 [94]	110 [137]	170 [212]	5/8-18	85 [106]	130 [162]	180 [225]
3/4-10	130 [162]	200 [250]	280 [350]	3/4-16	150 [188]	220 [275]	320 [400]
7/8-9	125 [156]	320 [400]	460 [575]	7/8-14	140 [175]	360 [450]	500 [625]
1-8	190 [237]	408 [506]	680 [850]	1-14	210 [263]	540 [675]	760 [950]
1-1/8-7	270 [337]	600 [750]	960 [1200]	1-1/8-12	300 [375]	660 [825]	1080 [1350]
1-1/4-7	380 [475]	840 [1050]	1426 [1782]	1-1/4-12	420 [525]	920 [1150]	1500 [1875]
1-3/8-6	490 [612]	1010 [1375]	1780 [2225]	1-3/8-12	560 [700]	1260 [1575]	2010 [2512]
1-1/2-6	650 [812]	1460 [1825]	2360 [2950]	1-1/2-12	730 [912]	1640 [2050]	2660 [3325]

METRIC:

Coarse thread metric class 10.9 fasteners and class 10.0 nuts and through hardened flat washers, phosphate coated, Rockwell "C" 38-45. Use value in [] if using prevailing torque nuts

Nominal thread diameter (mm)	Newton Meters (Standard Torque)	Foot Pounds (Standard Torque)	Nominal Thread Diameter (mm)	Newton Meters (Standard Torque)	Foot Pounds (Standard Torque)
6	10 [14]	7 [10]	20	385 [450]	290 [335]
7	16 [22]	12 [16]	24	670 [775]	500 [625]
8	23 [32]	17 [24]	27	980 [1105]	730 [825]
10	46 [60]	34 [47]	30	1330 [1470]	990 [1090]
12	80 [125]	60 [75]	33	1790 [1950]	1340 [1450]
14	125 [155]	90 [115]	36	2325 [2515]	1730 [1870]
16	200 [240]	150 [180]	39	3010 [3210]	2240 [2380]
18	275 [330]	205 [245]			

Hydraulic Fitting Torque Specifications

37 degree JIC, ORS, &ORB (REV. 10/97)

This chart provides tightening torques for general purpose applications when special torques are not specified on process or drawing. Assembly torques apply to plated nuts and capscrews assembled without supplemental lubrication (as received condition). They do not apply if special graphite moly-disulfide or other extreme pressure lubricants are used. When fasteners are dry (solvent cleaned) add 33% to as received condition torque. Bolt head identification marks indicate grade and may vary from manufacturer to manufacturer. Thick nuts must be used on grade 8 capscrews. Use value in [] if using prevailing torque nuts

TORQUE SPECIFIED IN FOOT POUNDS

PARKER® BRAND FITTINGS

Dash Size	37 Deg. JIC	O-ring (ORS)	O-ring boss
-4	11-13	15-17	13-15
-5	14-16	-----	21-23
-6	20-22	34-36	25-29
-8	43-47	58-62	40-44
-10	55-65	100-110	58-62
-12	80-90	134-146	75-85
-16	115-125	202-218	109-121
-20	160-180	248-272	213-237
-24	185-215	303-327	238-262
-32	250-290	-----	310-340

GATES® BRAND FITTINGS

Dash Size	37 Deg. JIC	O-ring (ORS)	O-ring boss
-4	10-11	10-12	14-16
-5	13-15	-----	-----
-6	17-19	18-20	24-26
-8	34-38	32-40	37-44
-10	50-56	46-56	50-60
-12	70-78	65-80	75-83
-14	-----	65-80	-----
-16	94-104	92-105	111-125
-20	124-138	125-140	133-152
-24	156-173	150-180	156-184
-32	219-243	-----	-----

AEROQUIP® BRAND FITTINGS

Dash Size	37 Deg. JIC	O-ring (ORS)	O-ring boss
-4	11-12	10-12	14-16
-5	15-16	-----	16-20
-6	18-20	18-20	24-26
-8	38-42	32-35	50-60
-10	57-62	46-50	75-80
-12	79-87	65-70	125-135
-14	-----	-----	160-180
-16	108-113	92-100	200-220
-20	127-133	125-140	210-280
-24	158-167	150-165	270-360

Fasteners

Before operating your Brillion machine, check all hardware for tightness. (See “General Torque Specifications” on page 4-1.)

After a few hours of use, check entire machine and tighten any loose nuts or bolts. Daily or periodic checks should be made thereafter.

When replacing bolts, be sure to use fasteners of equal grade.

Lubrication

Lubricate bearings with quality grease per recommended lubrication frequency intervals indicated or if machine is not used for an extended period.

Grease Wheel Hubs every 50 hours.

Repack Wheel Hub bearings annually before each season usage. See Figure 4-1.

Lubricate Drawbar and Bridge Hitch Pivot Pin every 12 hrs. See Figure 4-2.

⚠ CAUTION

Over lubrication of these bearings can cause premature bearing failure.

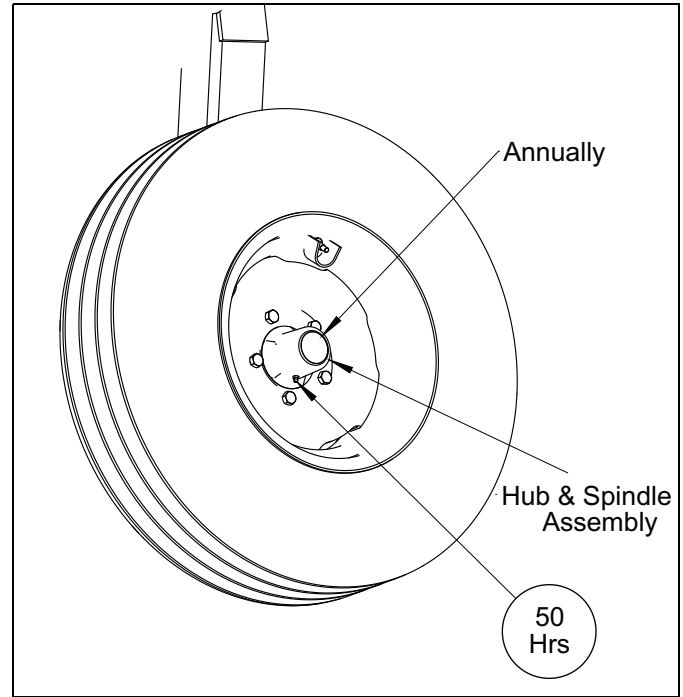

Figure 4-1: Tire and Hub Lubrication

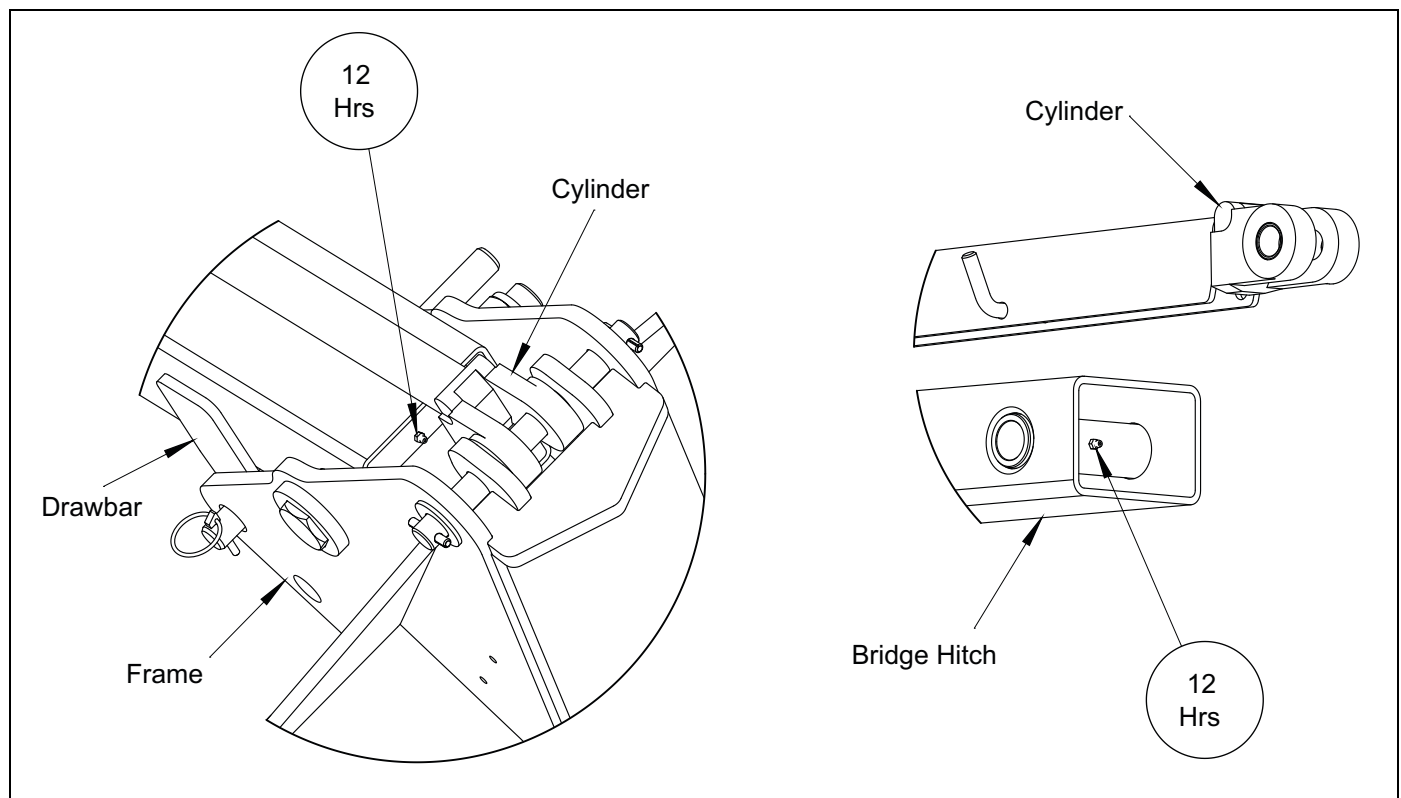

Figure 4-2: Drawbar and Bridge Hitch

Tires

CAUTION

Use of smaller or lighter tires will cause premature tire failure and may cause an accident.

All machines are shipped with 15 x 8LB, 6 Bolt Wheels which require 11L - 15 - 8 Ply Tires. Inflate to 36 PSI. After several hours of use re-torque Wheel Bolts 90-100 Ft-Lbs. For tightening sequence, **See Figure 4-3.**

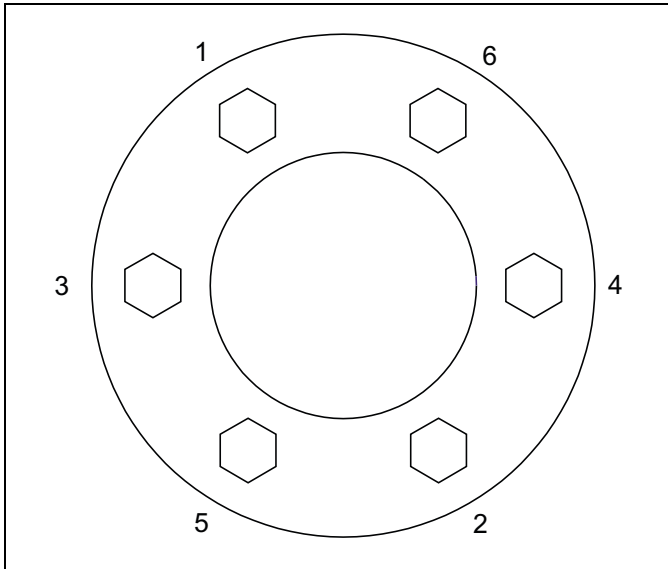

Figure 4-3: Wheel Bolt Tightening Sequence

CAUTION

Escaping fluid under pressure can be nearly invisible and have enough force to penetrate the skin causing serious injury. Use a piece of cardboard, rather than hands to search for suspected leaks. Wear protective gloves and safety glasses or goggles when working with the hydraulic system.

Hydraulic System

The first time the machine is connected to the tractor, or any time the hydraulic circuit is opened, air must be bled from the system

Check the hydraulic lines and cylinders for leaks before starting operation each day.

This machine is hydraulically controlled by one circuit which controls the lift of the machine. When the machine is not to be used for some time, exposed portions of the cylinder rods should be cleaned and covered with a thin coat of grease. This will prevent corrosion which will damage cylinder seals.

Replacing or Adding Roller Wheels

Attach a tractor to the Pulverizer, put the tractor transmission into PARK or lock the brakes preventing tractor from moving. Hydraulically raise the Pulverizer to the transport position and insert the transport pin. With the pulverizer in the transport position, slide all the wheels toward one end of the drum. Remove the transport pin and lower the machine so that the roller wheels rest on blocks approximately two inches off the ground. **See Figure 4-4.** Continue to lower the machine until the outside of the roller drum contacts the bottom ring of the roller wheels.

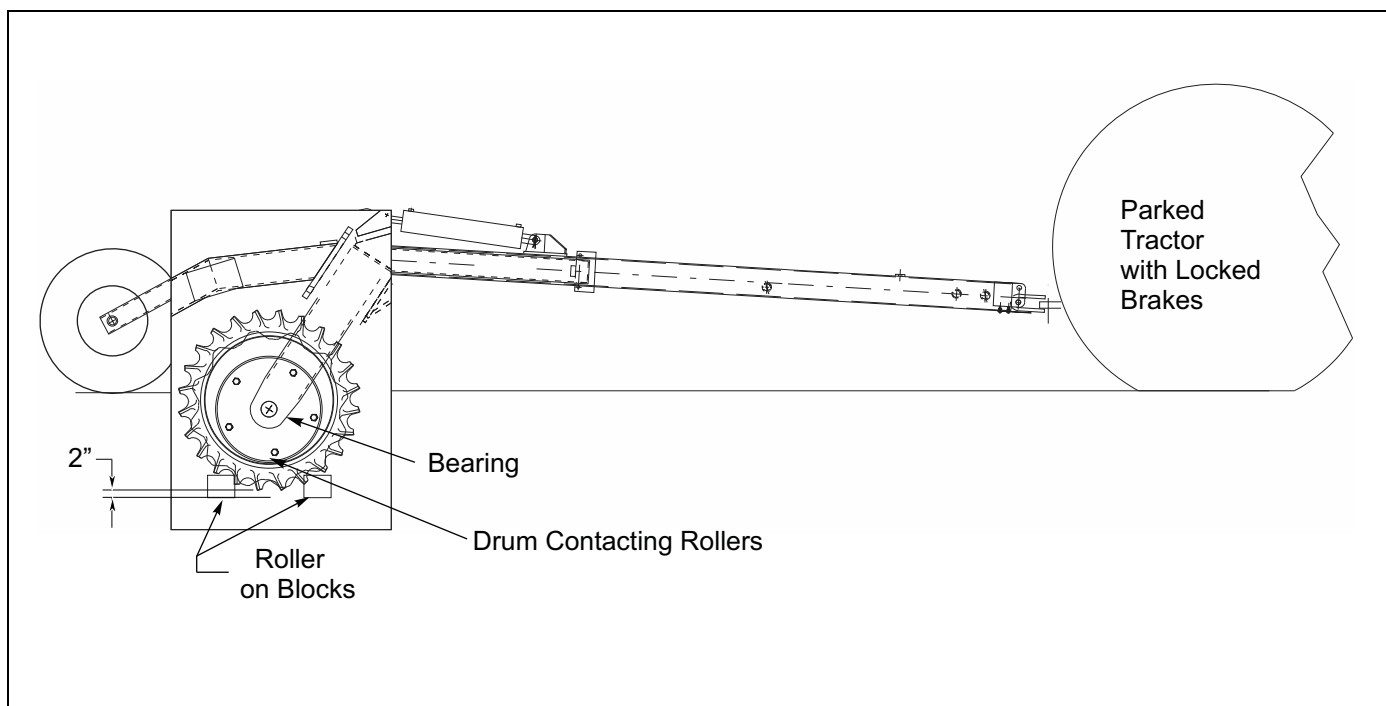

Figure 4-4: Replacing or Adding Roller Wheels 1 of 2

Remove the four 5/8-11 x 1-3/4 Bolts and Locknuts from the Flange Bearing attached to bearing hanger from the end of the drum to which you will be adding wheels.

Refer to “**General Torque Specifications**” on page 4-1. for proper bolt torque values. Note the different torque requirement for bolts with lock nuts.

Remove the 1-8 x 2-1/4 Bolt from the loosened roller end and all accompanying hardware. **See Figure 4-5.**

Remove the five 5/8-11 x 2-1/2 Bolts and Lockwashers which attach the Retainer Wheel to the drum and remove.

Replace or add wheels. Slide the replacement wheels onto the drum, ensuring that they are oriented in the same direction as the others.

Re-attach the Retainer Wheel using the five 5/8-11 x 2-1/2 Bolts and Lockwashers, and tighten.

Slide an 11 and 14 Gauge Shim Washers onto the Drum Stub, then the Flange Bearing followed by a 11 Gauge Shim Washer, Flat Top Washer, 3/8 inch Thick Washer, 1 inch Spring Washer and secure with 1-8 x 2-1/4 Bolt.

Tighten to 400 ft.-lb.

Position roller into the bearing hanger and secure using four 5/8-11 x 1-3/4 Bolts and Locknuts.

Hydraulically raise the Pulverizer to the transport position and insert the transport pin.

IMPORTANT

- If pre-assembled parts or fasteners are temporarily removed, remember where they go. It is best to keep the parts separated.
- Check that all working parts move freely, bolts are tight and cotter pins are spread.

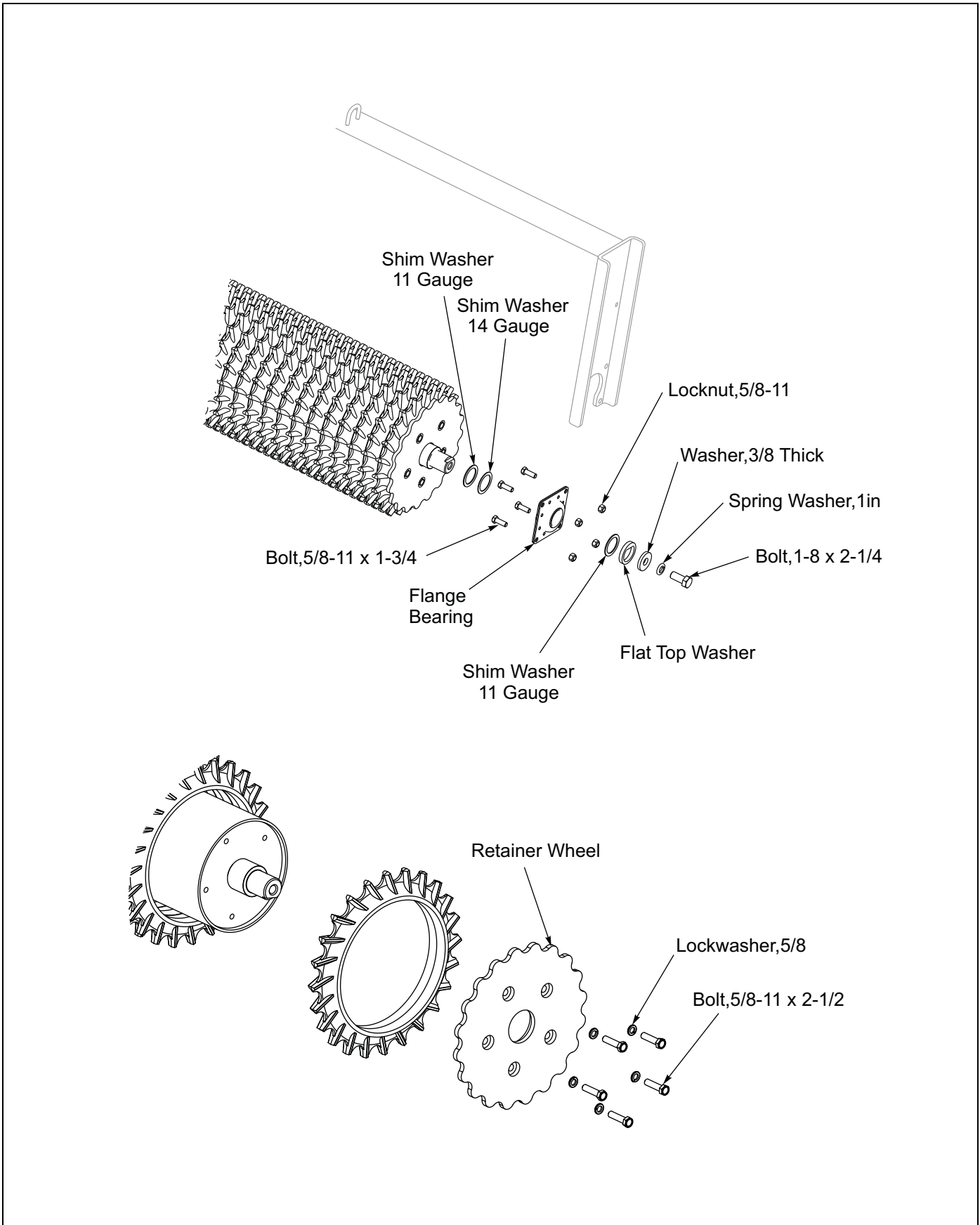

Figure 4-5: Replacing or Adding Roller Wheels 2 of 2

Storage

1. The service life of the Pulverizer will be extended by proper off-season storage practices. Prior to storing the unit, complete the following procedures:
 - a. Completely clean the unit.
 - b. Inspect the machine for worn or defective parts. Replace as needed.
 - c. Repaint all areas where the original paint is worn off.
 - d. Grease all exposed metal surfaces of shanks and points.
 - e. Apply a light coating of oil or grease to exposed cylinder rods to prevent them from rusting.
 - f. Lubricate each point of the machine as stated in **“Lubrication” on page 4-3.**
2. Store the unit in a shed or under a tarpaulin to protect it from the weather. The ground tools and tires should rest on boards, or some other object, to keep them out of the soil.
3. If the unit is stored in the folded position, make sure the transport lock is installed to prevent settling.
4. Relieve Hydraulic Pressure in hoses after lock is installed.
5. Block wheels before unhitching from tractor.

General Reference and Specifications

Table 5-1: Specifications

Standard Machine Specifications		
15" Road Clearance in Transport	LED Warning Lights & SMV Emblem	Powder Coat Paint, Red
Single Tractor Hydraulic Circuit	Roller Axle Size 8"	11L x 15 -8 Ply Tires on 6 Bolt Rims
Safety Chain		

Document Control Revision Log:

Date	Revision	Improvement(s) Description and Comments	Team Member
01/2015	R0	Initial Release	WML



Equipment from Landoll Corporation is built to exacting standards ensured by ISO 9001 registration at all Landoll manufacturing facilities.

Floating Ring Pulverizer PFT 20' and 22' Models Operator's Manual

Re-Order Part Number F-780R0

LANDOLL CORPORATION

1900 North Street

Marysville, Kansas 66508

(785) 562-5381

800-428-5655 ~ WWW.LANDOLL.COM



Copyright 2014. Landoll Corporation

"All rights reserved, including the right to reproduce this material or portions thereof in any form"