

OPERATOR'S MANUAL
REPAIR PARTS CATALOG

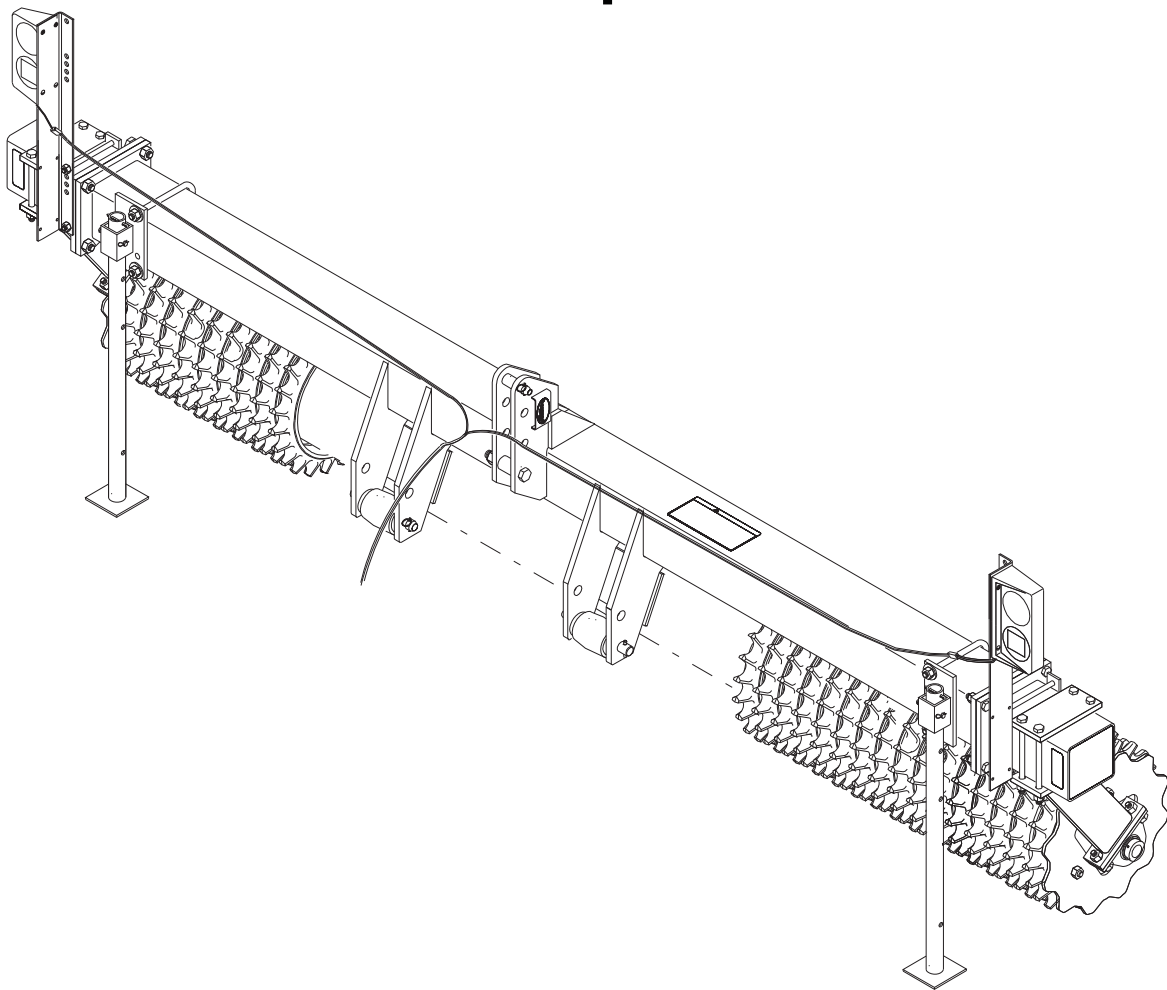

Floating Ring Pulverizer

Pick-up Model: PPF



1199rev401

BRILLION FARM EQUIPMENT
BRILLION, WISCONSIN 54110
www.brillionfarmeq.com

6K107

... **FLOATING RING PULVERIZERS**

CONTENTS

PART I - OPERATION

Introduction	3
Location Reference	3
Parts Ordering	3
Safety Suggestions	4
Safety Sign Description and Illustration	4
Decal Location	5
Machine Specifications	6
Operating Instructions	7
Stand Positioning	7
Fasteners	7
Attaching Tractors to Pulverizers	8
Category II Hitch	8
Category III Hitch	9
Field Operation	10
Replacing or Adding Rollers	11
Warning Lights	12

PART II - REPAIR PARTS

Frame	14
Roller	16
Roller Assemblies	18
Warning Lights	19
Index	20

INTRODUCTION

To obtain maximum benefits from the FLOATING RING PICKUP PULVERIZER, please study this manual carefully before starting assembly or operation. A special section, "Assembly Instructions", is included. If items in this manual are not understood, contact your local BRILLION dealer



The symbol shown here appears in this book and on your machine where special attention is needed to safeguard yourself against harm. It warns, "**ATTENTION! BE ALERT! YOUR SAFETY IS INVOLVED!**" The message following the symbol points out important safety precautions. Read it and be alert to the possibility of personal injury or death.

BE ALERT!
YOUR SAFETY IS INVOLVED

Location Reference

Right Hand, Left Hand, and Forward designations are made from the viewpoint of standing behind the machine and facing the direction it will travel during field operation.

Parts Ordering

When ordering parts for this machine, include the complete model number and serial number. Refer to the name plate on left side of the mast as shown in Figure 1. Please read and record this number upon taking delivery of this machine.

FLOATING PICKUP PULVERIZER Model _____

Serial Number _____

Date Purchased _____

Be sure to read the warranty card which is shipped with the machine. Return the proper portion of the card for recording at the factory.

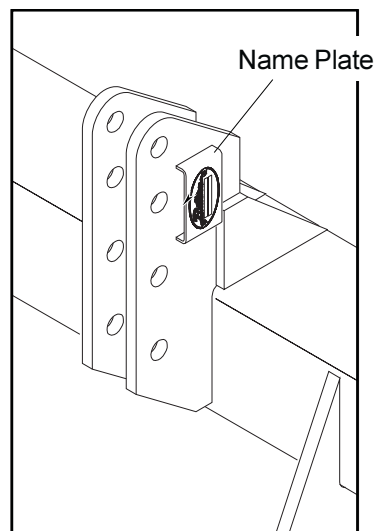

FIGURE 1



SAFETY SUGGESTIONS

Investigation has shown that nearly one-third of all farm accidents are caused by careless use of machinery. You can do your part in improving safety by observing the following suggestions. Insist that all people working with you or for you abide by them.

1. Do not stand between tractor and implement when attaching or detaching implement, unless neither are moving.
2. Do not allow anyone to ride on tractor or machine.
3. Lower machine to ground when not in use.
4. Unhitch implement from tractor on a level surface only. Use support stands and be sure they are fully secured with pins and hair pin cotters.
5. Do not transport at speeds over 20 MPH.
6. When transporting machine, avoid sudden stops or sharp turns because the weight of the machine may cause the operator to lose control of the tractor.
7. When transporting the machine on a road or highway, use adequate warning symbols, reflectors, lights and slow moving vehicle signs as required.
8. Securely block machine when working on or under it to prevent injury in case of hydraulic failure or inadvertent lowering by another person.



SAFETY WARNING SIGNS

The "WARNING" signs illustrated on this page are placed on the machine to warn of hazards. "The warnings found on the sign are for your personal safety and those around you." Their locations on the machine are shown on the following page. **OBSERVE THESE WARNINGS!**

Keep these signs clean so they can be observed readily. Wash with soap and water or cleaning solution as required.

Replace "WARNING" signs should they become damaged, painted over or if they are missing.

When replacing decals, clean the machine surface thoroughly using soap and water or cleaning solution to remove all dirt and grease.

Figure 2A



①



②



③

1. 8J309 - Decal, "Caution" list
2. 2J431 - Decal, Reflective Amber
3. 2J430 - Decal, Reflective Red

DECALS & LOCATIONS

Figure 2B

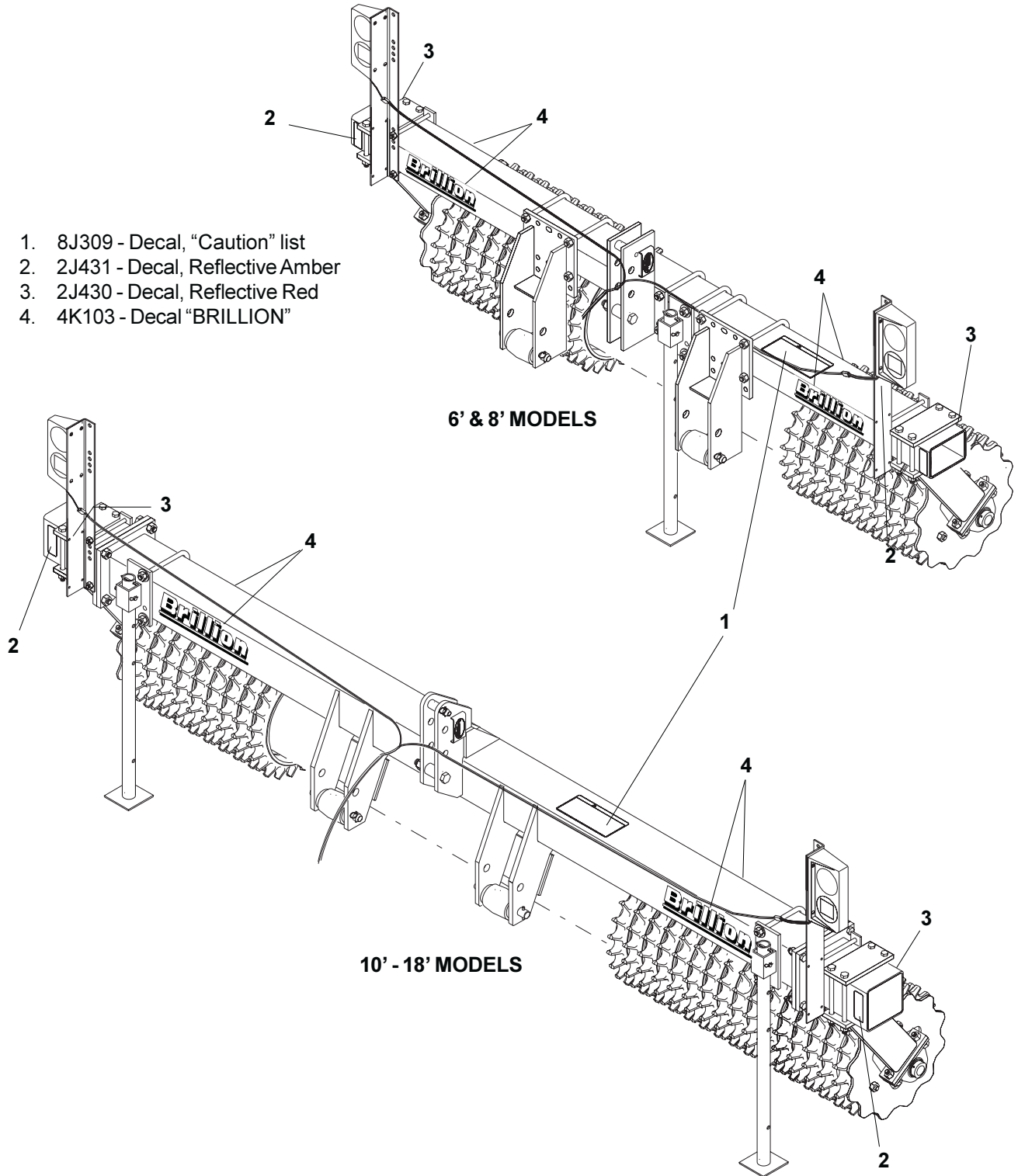

SPECIFICATIONS

Subject to change due to product improvement

Model Designation

Basic model is denoted by: **PPF**= **P**ickup **P**ulverizer with **F**loating ring wheels

Numbers following indicate machine widths in feet:

6', 8', 10', 12', 14', & 16' wide

Letter following indicates wheel size:

B=4K392; 20" O.D., 14" I.D.

Number following indicates

Pipe drum diameter sizes: 12"

EXAMPLE: PPF10B12 = Floating ring pulverizer which is 10 Feet wide and has 20" outside diameter wheels on a 12" pipe drum.

Basic Machine Specifications

Overall Width: The frame width is 15 1/2" wider than the rolling width in all sizes.

Overall length: Approximately 28 1/2"

Machine weights

There are 5 wheels per foot of machine width

"B" size wheels weigh 34 pounds each:

Machines with "B" wheels vary in weight from 245 lbs/ft to 266 lbs/ft of rolling width.

OPERATING INSTRUCTIONS



Securely block machine when working on or under it to prevent injury in case of hydraulic failure or inadvertent lowering by another person.

1. Stand Position

OPERATING POSITION

When operating, keep support stand locked up in raised position.

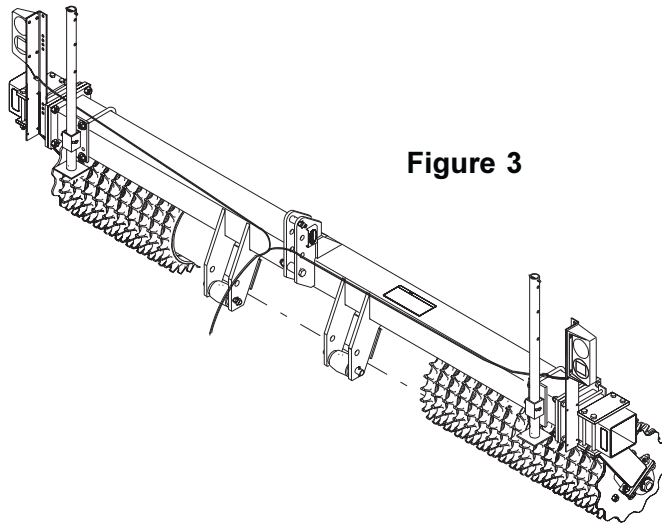
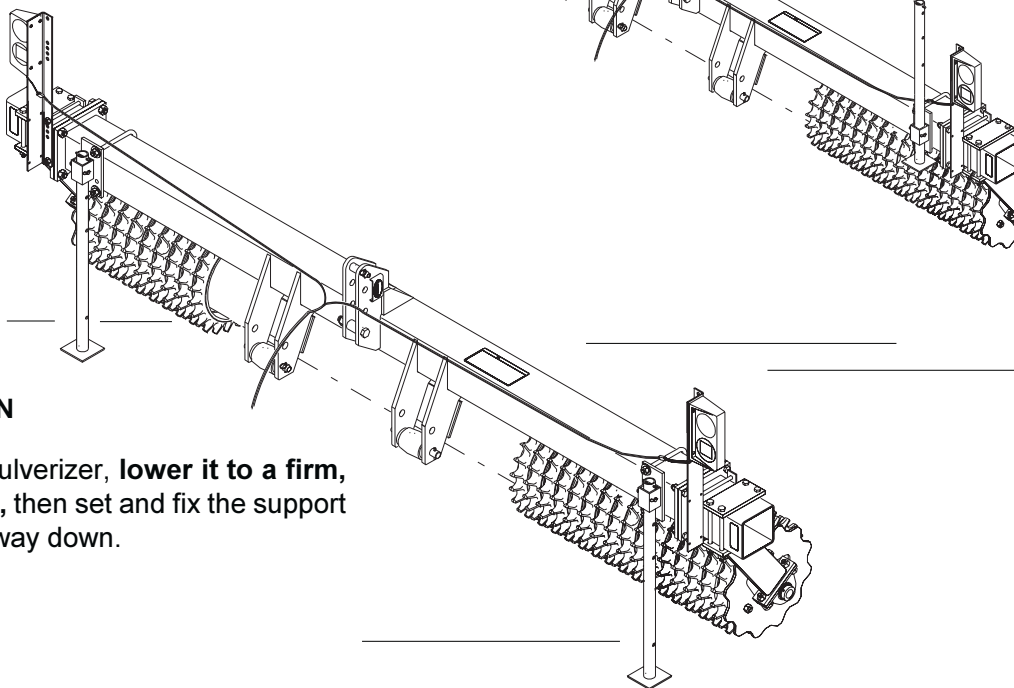

Figure 3



PARKED POSITION

To park the pulverizer, **lower it to a firm, level surface**, then set and fix the support stand all the way down.

Fasteners

After the first 1 - 2 hours of use, check over all fasteners to insure that they remain tight. Periodic checks should be made thereafter.

2. Attaching Tractors to Pulverizers

This pulverizer is designed to be mounted to tractors with a category II or a Category III 3-point hitch. Instructions for attachment are as follows:

With Category II Hitch

See Figure 4. Use the lower set of holes for the tractor lift arms to provide maximum transport clearance. (Upper holes are for other model machines).

Install lower hitch pins with cast iron spacers toward outside of machine. Secure with klik pins. The 1-7/16" O.D. Sleeves are not used.

For the Quick Coupler:

Use the bottom mast hole. Install the 1" x 4-1/2" cap screw, 1" x 2-1/8" pipe spacer, 1" lock nut, and tighten securely. Unused pin and sleeve may be stored in top hole.

For the Three-Point Free Link Hitch:

Use the second lower mast hole for the 1" clevis pin and klik pin. Install 1" x 4-1/2" cap screw and 1" x 2-1/8" pipe spacer in the bottom hole, attach lock nut, and tighten securely. The 1-1/4" O.D. x 1-15/16" sleeve is not used.



Be sure all hitch points seat properly. Watch for possible interference between pluverizer, and linkages when raising the first time.

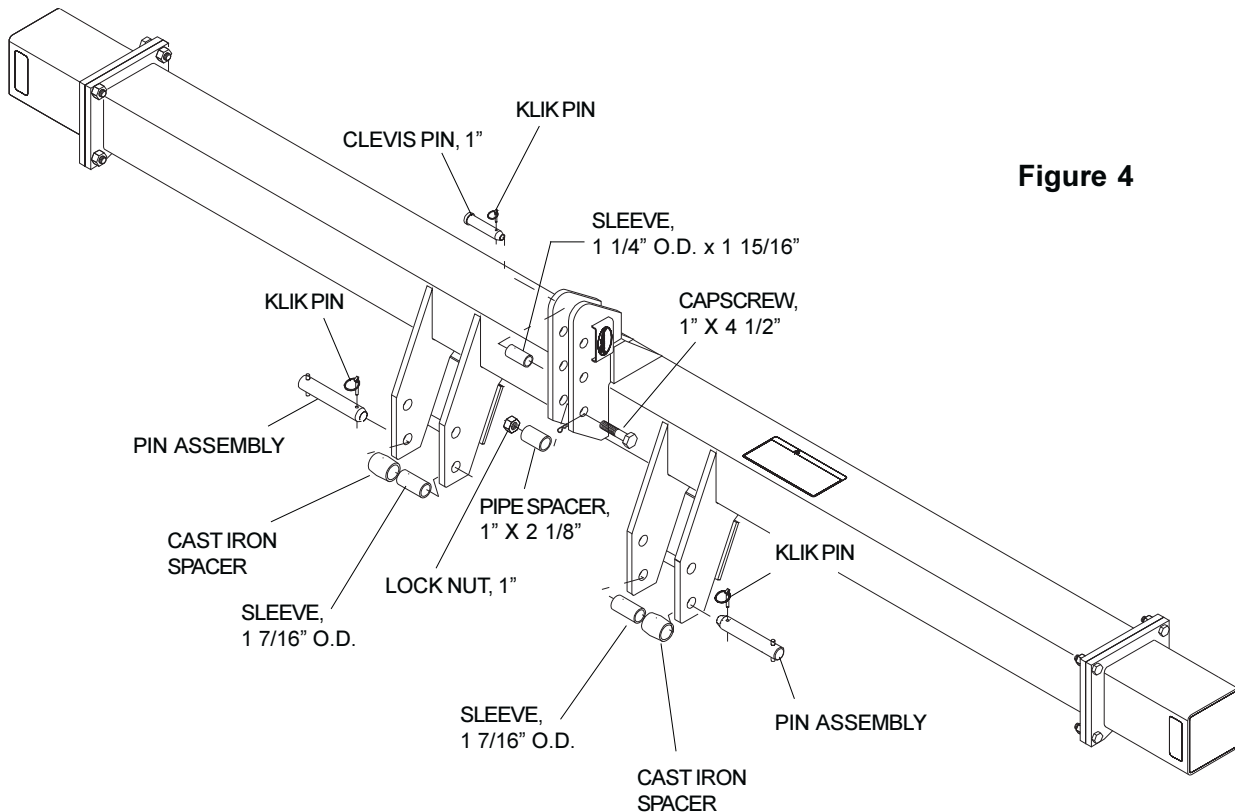

Figure 4

With Category III Hitch

See Figure 5. Use the lower set of holes for the tractor lift arms to provide maximum transport clearance. (Upper holes are for other model machines).

Install lower hitch pins with cast iron spacers inside of machine and 1-7/16" O.D. sleeves toward outside. Secure with klik pins.

For the Quick Coupler:

Use the second lowest mast hole for the 1" x 4-1/2" cap screw and 1" x 2-1/8" pipe spacer. Install the lock nut and tighten securely. Unused pin may be stored in top hole.

For the Three-Point Free Link Hitch:

Use the second highest mast hole and install the 1" clevis pin, 1-1/4" O.D. x 1-15/16" sleeve, and klik pin. Install 1" x 4-1/2" cap screw and 1" x 2-1/8" pipe spacer in the bottom hole, attach lock nut, and tighten securely.



Be sure all hitch points seat properly. Watch for possible interference between pulverizer, tractor, and linkages when raising the first time.

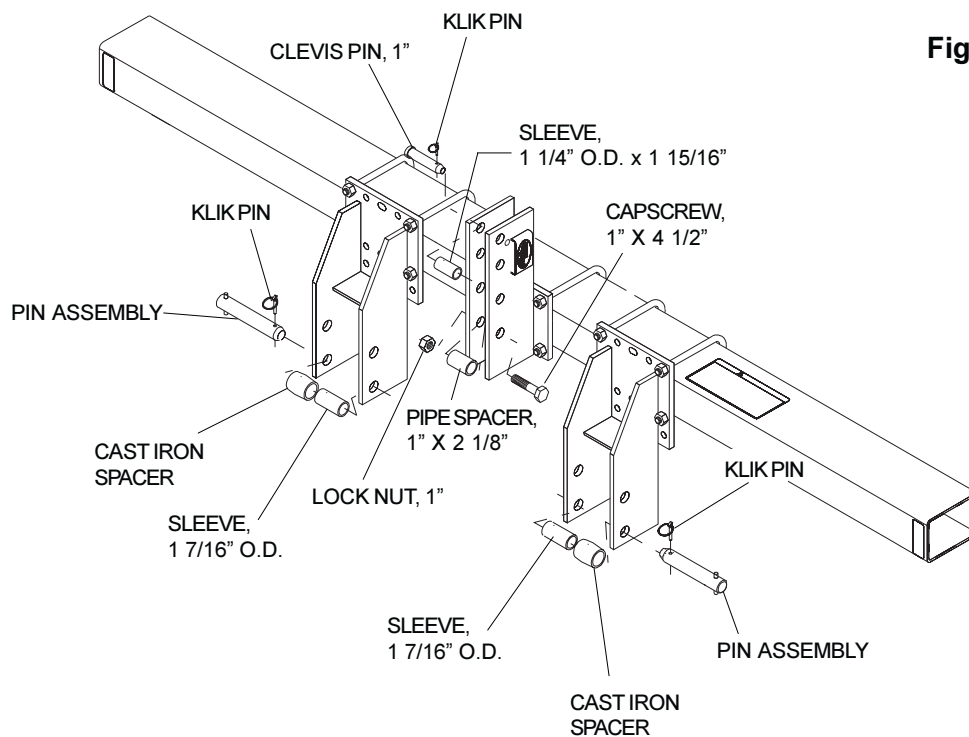
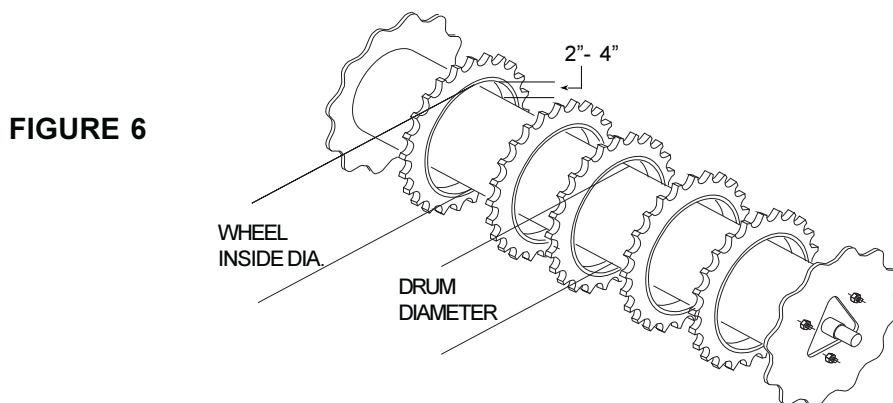

Figure 5

Field Operation

The floating ring pulverizer is designed with rings whose inside diameter is two to four inches greater than the drum which supports them. This allows the packer wheels to follow the irregular contours in your fields.



The drum assembly can be mounted to the frame in two ways. When mounted as shown in figure 7A, the wheels will have a tendency to pack the soil. When the wheels are mounted as shown in figure 7B, the wheels will act more like a rotary hoe and will have a tendency to loosen the soil. To change the mounting of the wheel and drum assembly to the frame, follow these steps:

1. Lower the wheels to the ground.
2. Support the frame with a tractor lift.
3. Remove the bolts which hold the pillow block bearings to the frame.
4. Raise the frame above the roller assembly.
5. Drive tractor with frame around to opposite side of rollers.
6. Re-attach the pillow block bearings to the frame.

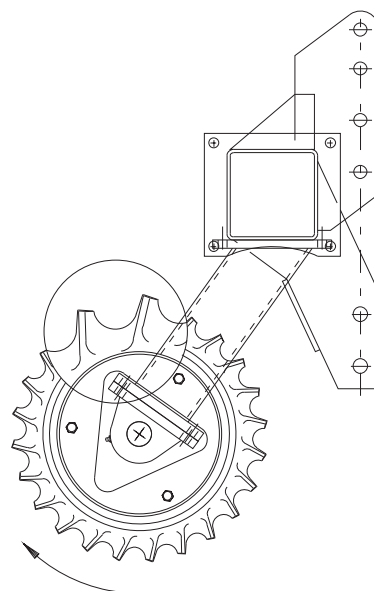
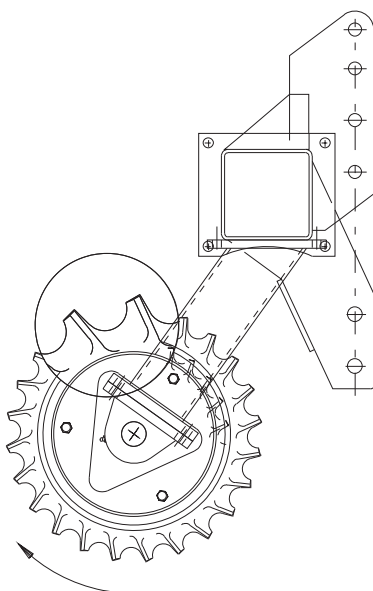

REPLACING OR ADDING ROLLER WHEELS

Although the packer wheels are manufactured from high grade ductile iron, wear or breakage may require that some wheels be periodically replaced. Follow these steps when replacing wheels.

1. Attach a tractor to the pulverizer, put the tractor transmission into PARK, and lock the brakes on the tractor.

Hydraulically raise the pulverizer. Slide all the wheels toward one end of the drum.

Lower the pulverizer so that the packer wheels rest on blocks approximately two inches off the ground (see figure 8).

Continue to lower the machine till the outside of the roller drum contacts the bottom ring of the packer wheels.

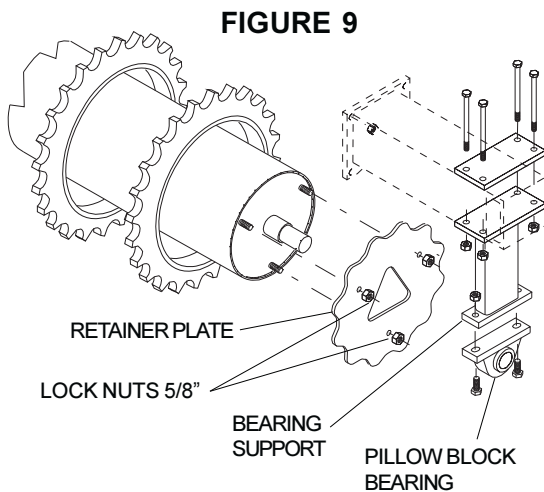
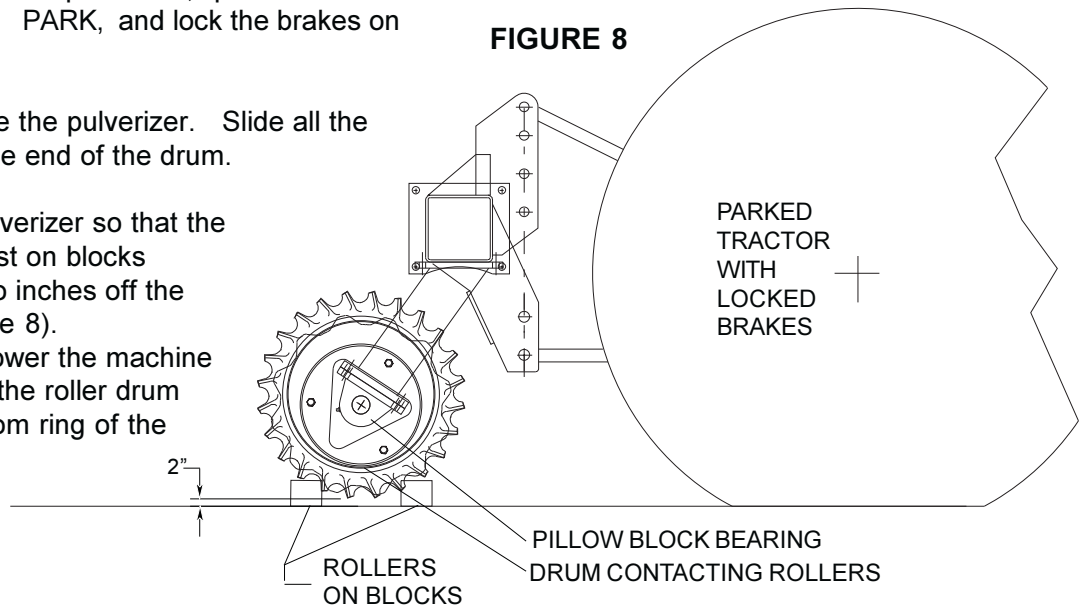

2. Remove the pillow block bearing and the bearing support from the end of the drum to which you will be adding wheels. The pillow block bearing is secured to the drum shaft by means of an eccentric locking collar.

Loosen the set screws which tighten the collar to the shaft. Then with a punch, rotate the collar in the direction opposite which the shaft turns in normal operation.

Next remove the nuts from the bolts which mount the bearing supports to the frame and slide the bearing and the support off the shaft.

Remove the three 5/8" lock nuts which attach the retainer plate to the drum and remove the plate.

3. Slide the replacement wheels onto the drum, replace the retainer and tighten the lock nuts to 150 ft.-lb.

Slide the pillow block bearing and bearing support onto the shaft until the bearing bottoms against the shaft shoulder.

Replace the bolts which mount the bearing support to the frame and tighten the lock nuts to 150 ft.-lb.

Now take a punch and rotate the locking collar of the bearing in the direction which the bearing will rotate and tighten the set screw against the shaft.

WARNING LIGHT ASSEMBLY

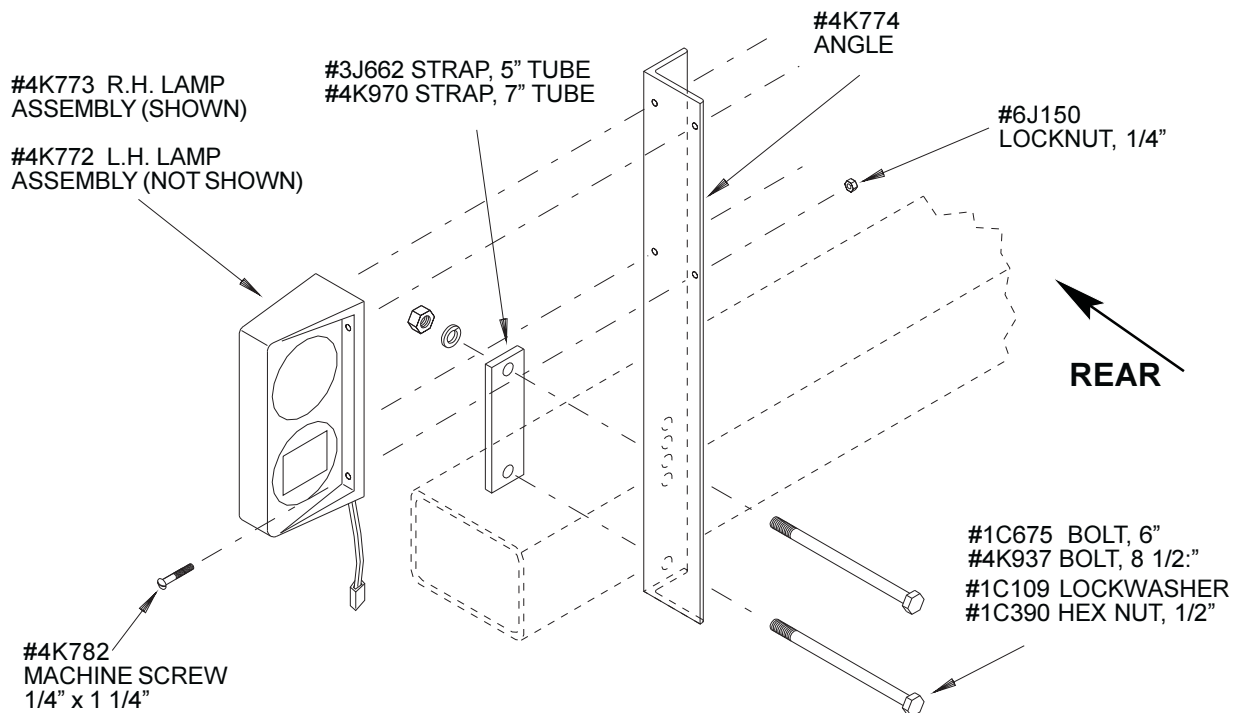

1. Assemble #4K774 to right side of machine frame member. Attach as far to outside of frame as possible using straps and machine bolts or U-bolts as furnished. See illustration above. Assemble the other angle in similar fashion on the left side of machine.
2. Attach lamp assemblies with fasteners shown (amber facing forward; red and amber facing toward the rear with amber above red).
3. Connect "wishbone" wiring harness ends to connectors on lamp assemblies. (**IMPORTANT: wires are color coded on wishbone harness. Connect end with yellow wire to left side lamp assembly. Connect end with green wire to right side lamp assembly.**) Run wishbone harness wires along rear frame member to center of machine.
4. At center of machine assemble the connector of the straight harness to the wishbone harness. The 7-pin plug on the straight harness connects to the tractor socket when in use. Allow enough harness length to reach tractor socket and roll or fold up excess. Attach permanently to pulverizer frame. All wires must be firmly attached to machine frame members so they don't droop or become torn loose by field debris. Use plastic cable ties, provided, and electrical tape to secure all wiring.

37 **Brillion**

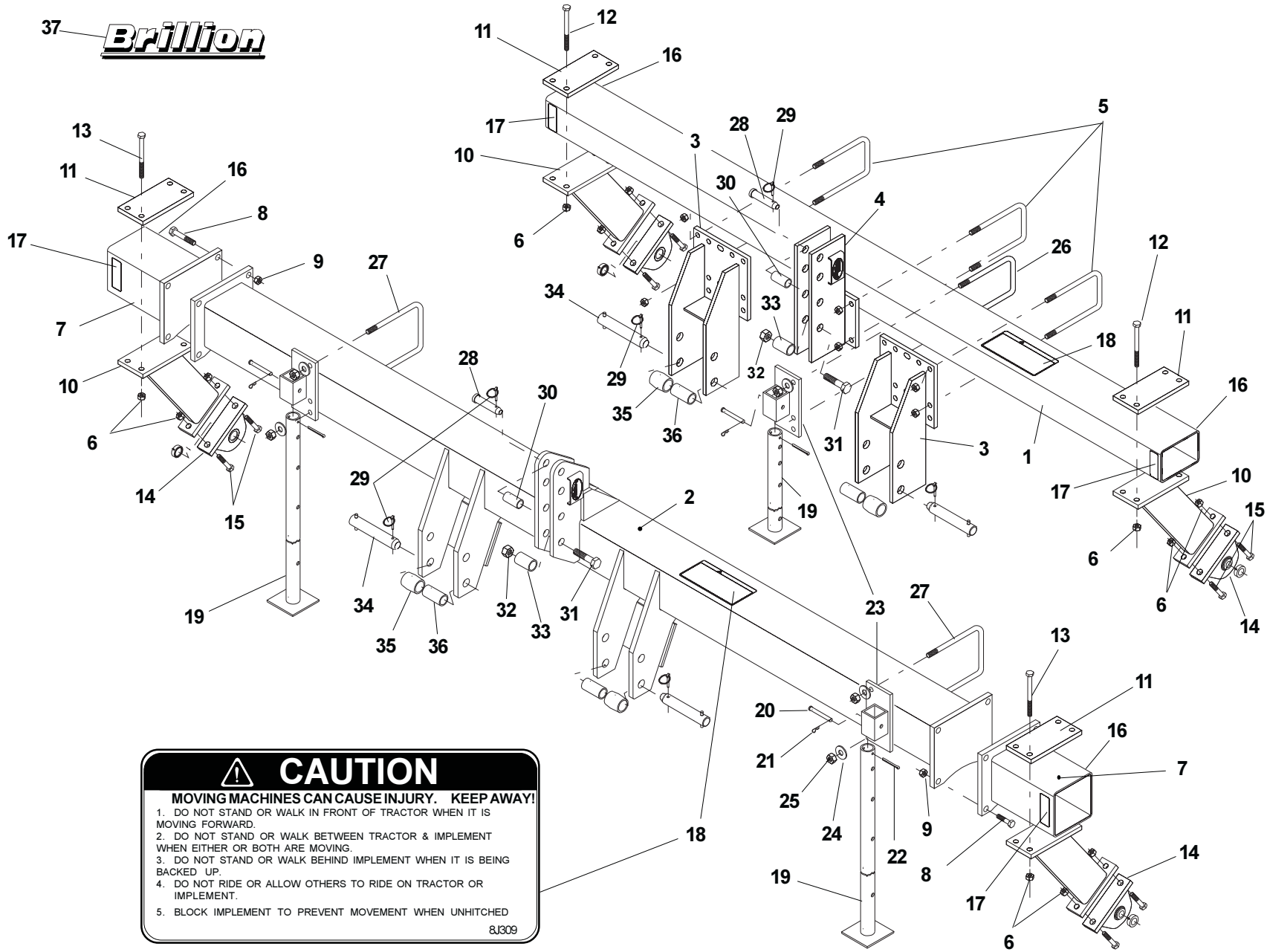

CAUTION
MOVING MACHINES CAN CAUSE INJURY. KEEP AWAY!
1. DO NOT STAND OR WALK IN FRONT OF TRACTOR WHEN IT IS MOVING FORWARD.
2. DO NOT STAND OR WALK BETWEEN TRACTOR & IMPLEMENT WHEN EITHER OR BOTH ARE MOVING.
3. DO NOT STAND OR WALK BEHIND IMPLEMENT WHEN IT IS BEING BACKED UP.
4. DO NOT RIDE OR ALLOW OTHERS TO RIDE ON TRACTOR OR IMPLEMENT.
5. BLOCK IMPLEMENT TO PREVENT MOVEMENT WHEN UNHITCHED
8J309

FRAME

Index No.	Part No.	Description	No. Req'd	Wt.
1	5K812	Tube - 6' Machine	1	106.00
	5K811	Tube - 8' Machine	1	135.00
2	5K766	Frame, 10' - 18' Machines	1	395.00
3	1K247	Hitch Bracket	2	25.00
4	1K282	Mast	1	37.50
5	1J801	U-bolt, 5/8"	6	1.50
6	5C461	Lock Nut, 5/8-11 Hex Stover	24	.07
7	4K989	Extension, 1 Ft.	2	43.00
	4K990	Extension, 2 Ft.	2	65.00
	4K991	Extension, 3 Ft.	2	87.00
	6K309	Extension, 4 Ft.	2	112.00
8	3D510	Capscrew, 3/4" x 2 1/2" gr. 5	8	.43
9	6C729	Lock Nut, 3/4-10 NC Hex Stover	8	.12
10	5K769	Bearing Support	2	24.80
11	5K196	Plate	2	7.30
12	6D303	Bolt, 5/8" x 7 1/2" gr. 5	8	.86
13	5J912	Bolt, 5/8" x 9 1/2" gr. 5	8	.70
14	4K993	Pillow Block Bearing, 1 15/16"	2	6.63
15	1D445	Capscrew, 5/8" x 2 1/2" gr. 5	4	.28
16	2J430	Reflective Decal, Red	2	-
17	2J431	Reflective Decal, Amber	2	-
18	8J309	Decal, Caution List	1	-
-	1J847	Stand Assembly (items 19-22)	1 2	9.60
19	9D047	Stand Weldment	1	9.40
20	3C335	Clevis Pin	1	.20
21	6C400	Hairpin Cotter	1	-
22	6D049	Cotter Pin	1	-
23	7J375	Stand Bracket	1 2	8.20
24	1B166	Washer	2	-
25	1C392	Nut	2	.07
26	1J801	U-Bolt	1	1.50
27	9D112	U-Bolt, 7"	2	1.76
28	6D529	Clevis Pin, 1"	1	1.1
29	5D110	Klik Pin,	3	.10
30	5D157	Sleeve, 1 1/4" O.D. x 1 15/16"	1	.20
31	8D922	Capscrew, 1" x 4 1/2"	1	1.24
32	6D306	Lock Nut, 1"	1	.28
33	6D988	Pipe Spacer, 1" x 2 1/8"	2	.30
34	8D424	Pin Assembly	2	2.5
35	8D425	Cast Iron Spacer	2	1.60
36	5D158	Sleeve, 1 7/16" O.D.	2	.50
37	4K103	Decal, "Brillion"	4	-

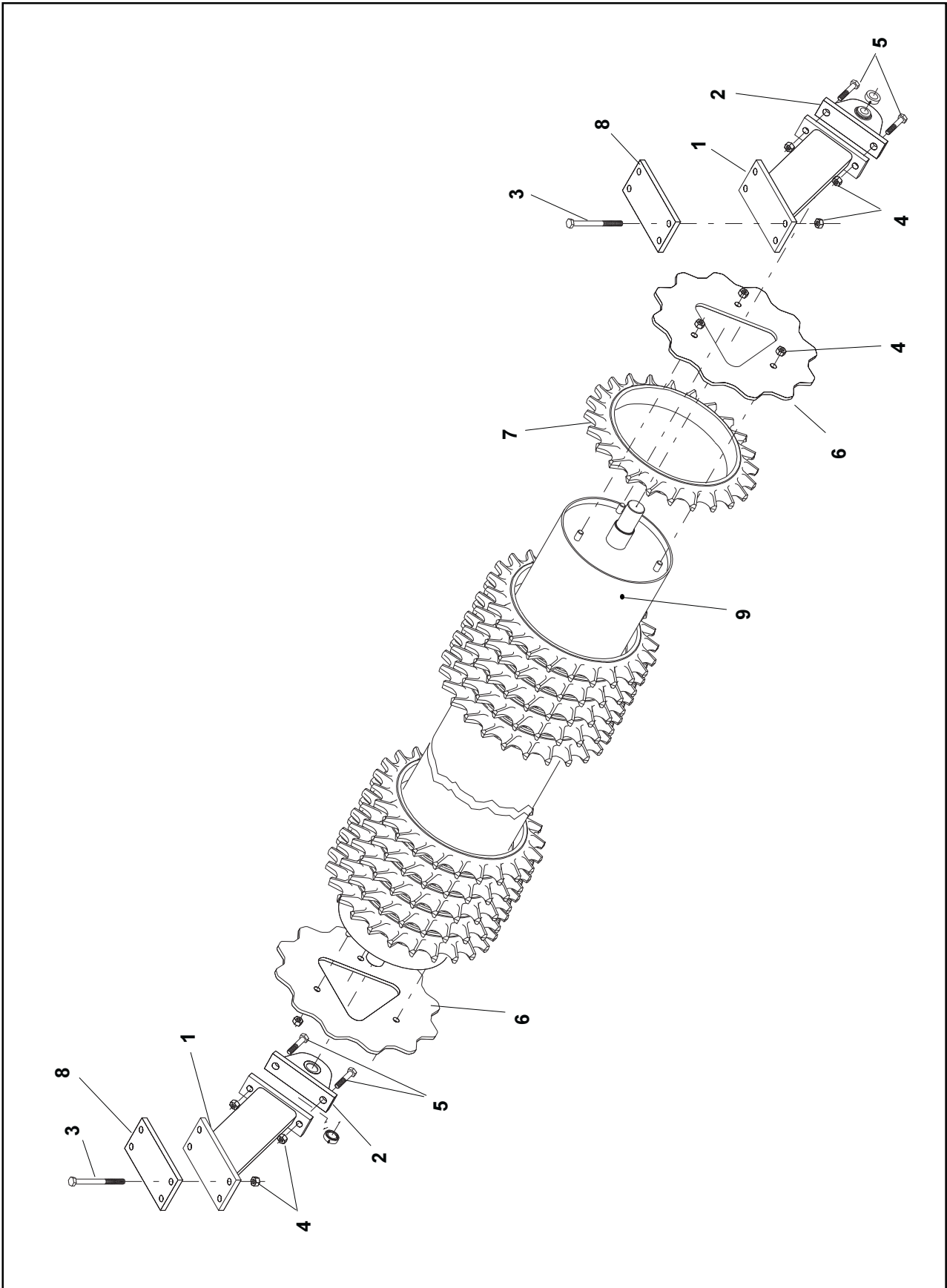

ROLLER

Index No.	Part No.	Description	No. Req'd	Wt.
1	5K769	Bearing Support	2	24.80
2	4K993	Pillow Block Bearing with Collar	2	6.63
3	5J912	Bolt, 5/8-11 NC x 9 1/2" Long (10' - 16' Machines)	4	2.86
	6D303	Bolt, 5/8-11 NC x 7 1/2" Long (6' & 8' Machines)	4	.70
4	5C461	Lock Nut, 5/8-11 Hex	18	.07
5	1D445	Capscrew, 5/8" x 2 1/2"	4	.28
6	4K988	Retainer, 19"	2	21.00
7	4K392	"B"-Size Wheel, 20" O.D., 14" I.D.	-	34.00
8	5K196	Plate	2	7.30
9	5K815	Drum - 12" pipe x 6' Long	1	226.00
	5K816	Drum - 12" pipe x 8' Long	1	276.00
	5K031	Drum - 12" pipe x 10' Long	1	326.00
	5K032	Drum - 12" pipe x 12' Long	1	376.00
	5K033	Drum - 12" pipe x 14' Long	1	426.00
	5K034	Drum - 12" pipe x 15' Long	1	451.00
	5K035	Drum - 12" pipe x 16' Long	1	476.00
	6K313	Drum - 12" pipe x 18' Long	1	526.00

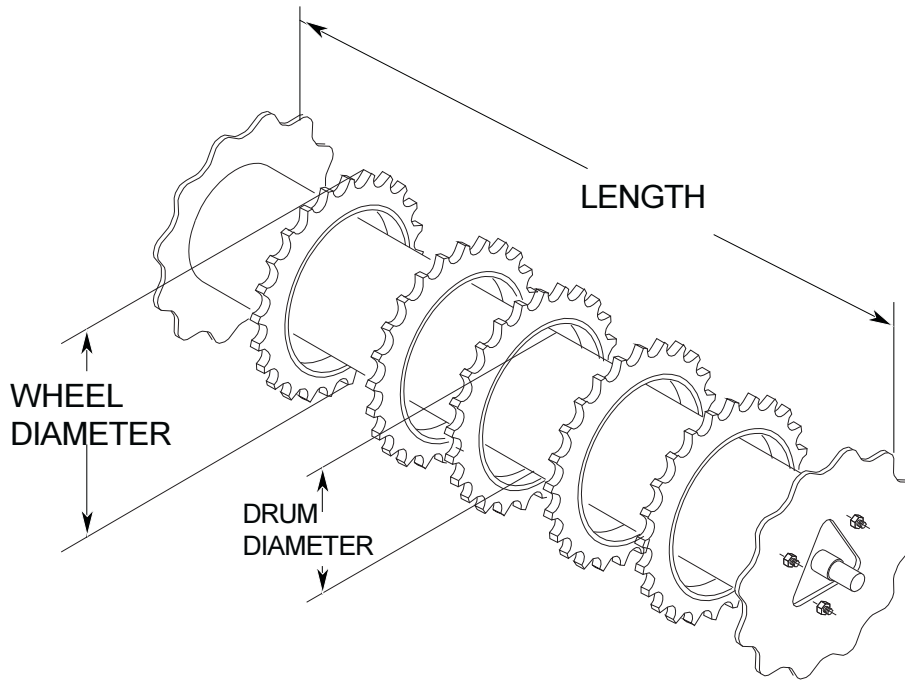

ROLLER ASSEMBLIES

	<u>Assembly No.</u>	<u>Drum (Pipe) Diameter</u>	<u>Wheel Dia. (In inches)</u>	<u>Length (In feet)</u>	<u>Used on Pulv. Model #</u>	<u>Roller Assem. Wt. (#)</u>
1	5K810	12" Pipe	20	6	PPF6B12	1288
2	5K809	12" Pipe	20	8	PPF8B12	1678
3	5K066	12" Pipe	20	10	PPF10B12	2068
4	5K067	12" Pipe	20	12	PPF12B12	2458
5	5K068	12" Pipe	20	14	PPF14B12	2848
6	5K064	12" Pipe	20	15	PPF15B12	3043
7	5K070	12" Pipe	20	16	PPF16B12	3240
8	6K310	12" Pipe	20	18	PPF18B12	3640

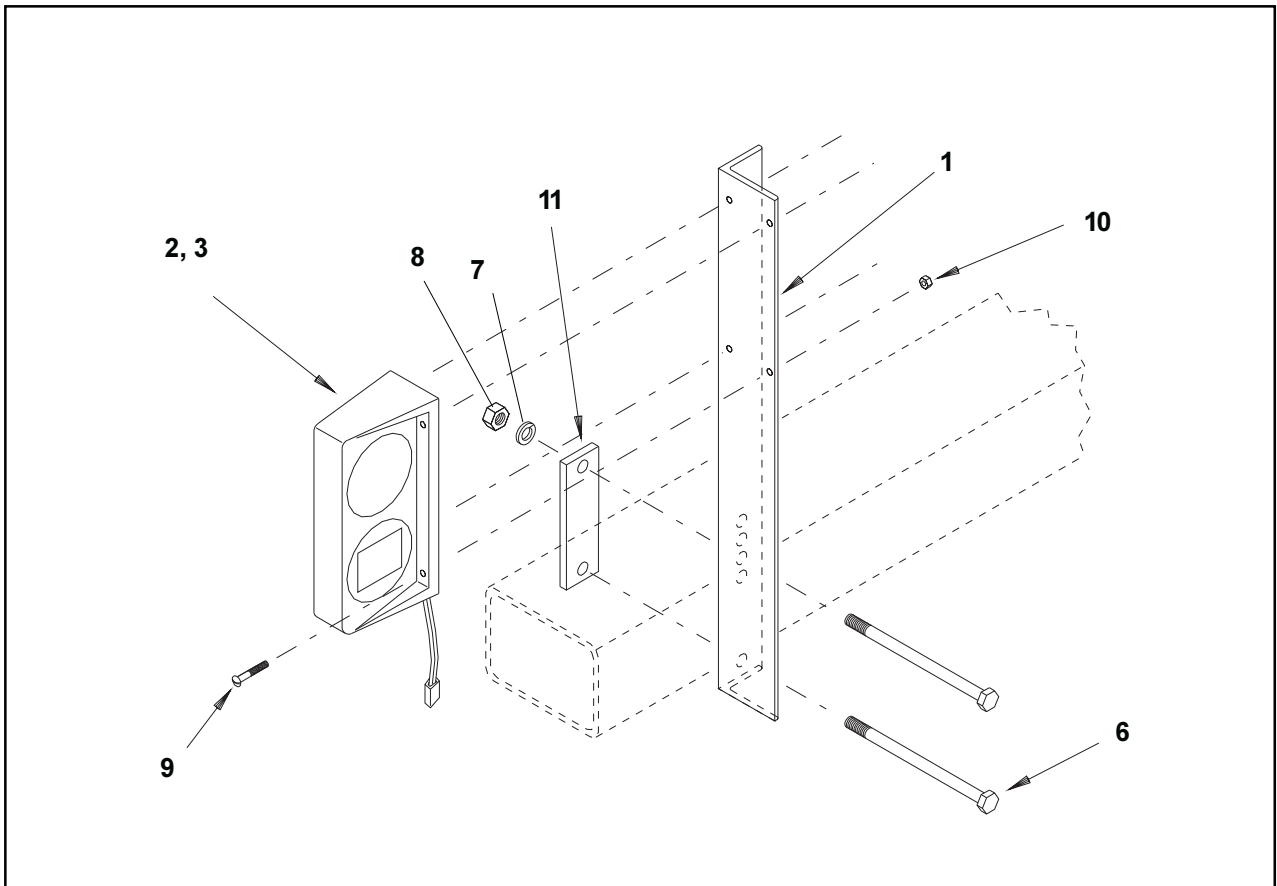

4K938 WARNING LIGHT KIT

Index No.	Part No.	Description	No. Req'd	Wt.
1	4K774	Angle	2	7.70
2	4K772	Dual Lamp, L.H.	1	2.00
3	4K773	Dual Lamp, R.H.	1	2.00
4	4K828	Wishbone Harness, 15' (not shown)	1	3.00
5	4K936	Ag. Harness, 10' (not shown)	1	2.00
6	4K937	Machine Bolt, 1/2" x 8 1/2"	4	.70
7	1C109	Lock Washer, 1/2"	4	-
8	1C390	Hex Nut, 1/2"	4	.04
9	4K782	Machine Screw, 1/4" x 1 1/4"	8	-
10	6J150	Flange Lock Nut, 1/4"	8	.01
11	3J662	Strap	2	1.60
12	3J615	Plastic Cable Tie, 28" (not shown)	11	-
13	4K940	Instruction Sheet	1	-

INDEX

<u>Part No.</u>	<u>Page</u>	<u>Index No.</u>	<u>Part No.</u>	<u>Page</u>	<u>Index No.</u>	<u>Part No.</u>	<u>Page</u>	<u>Index No.</u>
B								
1B166	15	24	4K990	15	7			
			4K991	15	7			
			4K993	15	14			
			4K993	17	2			
			5K031	17	9			
			5K032	17	9			
			5K033	17	9			
			5K034	17	9			
			5K035	17	9			
			5K066	18	3			
			5K067	18	4			
			5K068	18	5			
			5K069	18	6			
			5K070	18	6			
			5K196	15	11			
			5K196	17	8			
			5K766	15	2			
			5K769	15	10			
			5K769	17	1			
			5K809	18	2			
			5K810	18	1			
			5K811	15	1			
			5K812	15	1			
			5K815	17	9			
			5K816	17	9			
			6K309	15	7			
			6K310	18	8			
			6K313	17	9			
D								
1D445	15	15						
1D445	17	5						
3D510	15	8						
5D110	15	29						
5D157	15	30						
5D158	15	36						
6D049	15	22						
6D303	15	12						
6D303	17	3						
6D306	15	32						
6D529	15	28						
6D988	15	33						
8D424	15	34						
8D425	15	35						
8D922	15	31						
9D047	15	19						
9D112	15	27						
J								
1J801	15	5						
1J801	15	26						
1J847	15	-						
2J430	15	16						
2J431	15	17						
5J912	15	13						
5J912	17	3						
7J375	15	23						
8J309	15	18						
K								
1K247	15	3						
1K282	15	4						
4K103	15	37						
4K392	17	7						
4K988	17	6						
4K989	15	7						



Intertek

Equipment from Landoll Corporation is built to exacting standards ensured by ISO 9001 registration at all Landoll manufacturing facilities.

LANDOLL CORPORATION

1900 North Street

Marysville, Kansas 66508

(785) 562-5381

800-428-5655 ~ WWW.LANDOLL.COM



Copyright 2010. Landoll Corporation

"All rights reserved, including the right to reproduce this material or portions thereof in any form"