



Parts Manual

Mfg. No: 1696811-02
SELECT 1024MD, 11.5 Gross TP 24"
Steerable Dual Stage Snowthrower



Model Components	Page
Auger Drive Group.....	4
Auger Housing Group.....	8
Controls Group.....	10
Decals Group.....	14
Discharge Chute Group.....	16
Engine & Frame Group.....	20
Handles Group.....	24
Transaxle Drive Group.....	26
Wheels & Tires Group.....	32
Torque Specification Chart.....	34

Not For
Reproduction

Auger Drive Group

Note: Unless noted otherwise, use the standard torque specifications

Mfg. No: 1696811-02

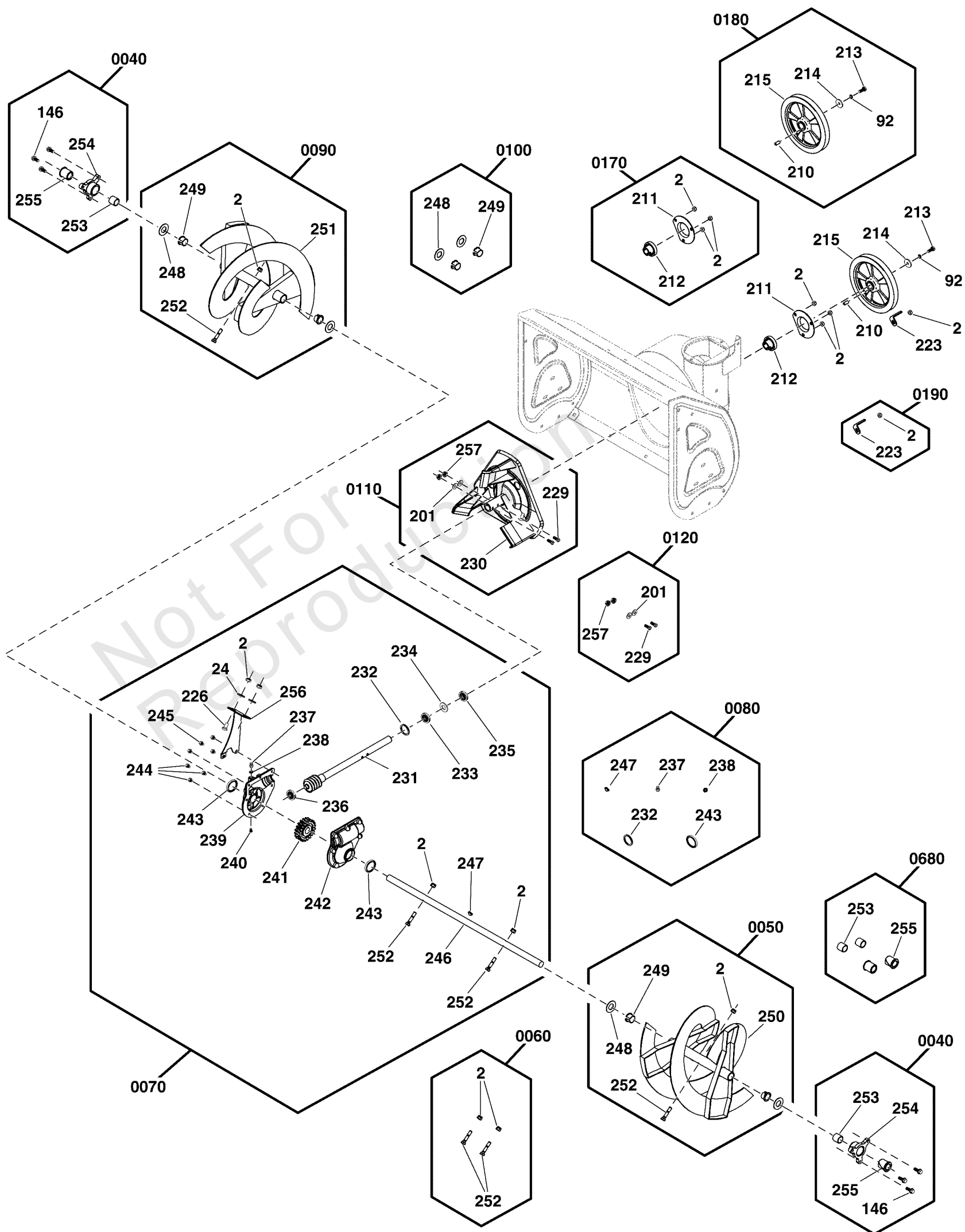

Auger Drive Group

REF NO	PART NO	QTY	DESCRIPTION
0040	707553	2	KIT, Mounting Plate, Auger Housing -(Incl. Ref. Nos. 146, 253, 254, 255)
146	-----	3	SCREW, Hex Head, M8 X 16
253	-----	1	BEARING, Sleeve
254	-----	1	RETAINER, Auger Shaft
255	-----	1	BEARING, Auger Shaft
0050	771721	1	KIT, Auger Assembly, Left -(Incl. Ref. Nos. 2, 248, 249, 251, 252)
2	-----	1	NUT, Lock, M8
248	-----	2	WASHER, Flat
249	-----	2	BEARING, Auger Shaft
250	-----	1	AUGER, 24", Left, Black
252	-----	1	BOLT, Hex, M8 X 38
0060	707555	1	KIT, SHEAR PIN, AUGER -(Incl. Ref. Nos. 2, 252)
2	-----	2	NUT, Lock, M8
252	-----	2	BOLT, Hex, M8 X 38
0070	84001614	1	KIT, Gearbox -(Incl. Ref. Nos. 2, 24, 226, 231, 232, 233, 234, 235, 236, 237, 238, 239, 240, 241, 242, 243, 244, 245, 246, 247, 252, 256)
2	-----	4	NUT, Lock, M8
24	-----	2	WASHER, 8x22x2, Flat
226	-----	2	BOLT, Carriage, M8 X 18
231	-----	1	SHAFT, Impeller Wormgear
232	-----	1	SEAL, Oil
233	-----	1	BEARING
234	-----	1	WASHER, Flat
235	-----	1	BEARING
236	-----	1	BEARING
237	-----	1	ZERK, Grease Fitting
238	-----	1	WASHER, Wave
239	-----	1	GEAR CASE, Right
240	-----	1	BOLT, Phillips Head, M5 X 10
241	-----	1	GEAR, Worm
242	-----	1	GEAR CASE, Left
243	-----	2	SEAL, Oil
244	-----	6	SCREW, Hex Head, M6 X 20
245	-----	1	BOLT, Hex, M6 X 25
246	-----	1	SHAFT, Auger Out
247	-----	1	KEY, WOODRUFF
252	-----	2	BOLT, Hex, M8 X 38
256	-----	1	PLATE, Auger Support
0080	707558	1	KIT, Seal, Gear Box -(Incl. Ref. Nos. 232, 237, 238, 243, 247)
232	-----	1	SEAL, Oil
237	-----	1	ZERK, Grease Fitting
238	-----	1	WASHER, Wave
243	-----	2	SEAL, Oil
247	-----	2	KEY, WOODRUFF
0090	771725	1	KIT, Auger Assembly, Right -(Incl. Ref. Nos. 2, 248, 249, 250, 252)
2	-----	1	NUT, Lock, M8
248	-----	2	WASHER, Flat

Auger Drive Group

Note: Unless noted otherwise, use the standard torque specifications

Mfg. No: 1696811-02

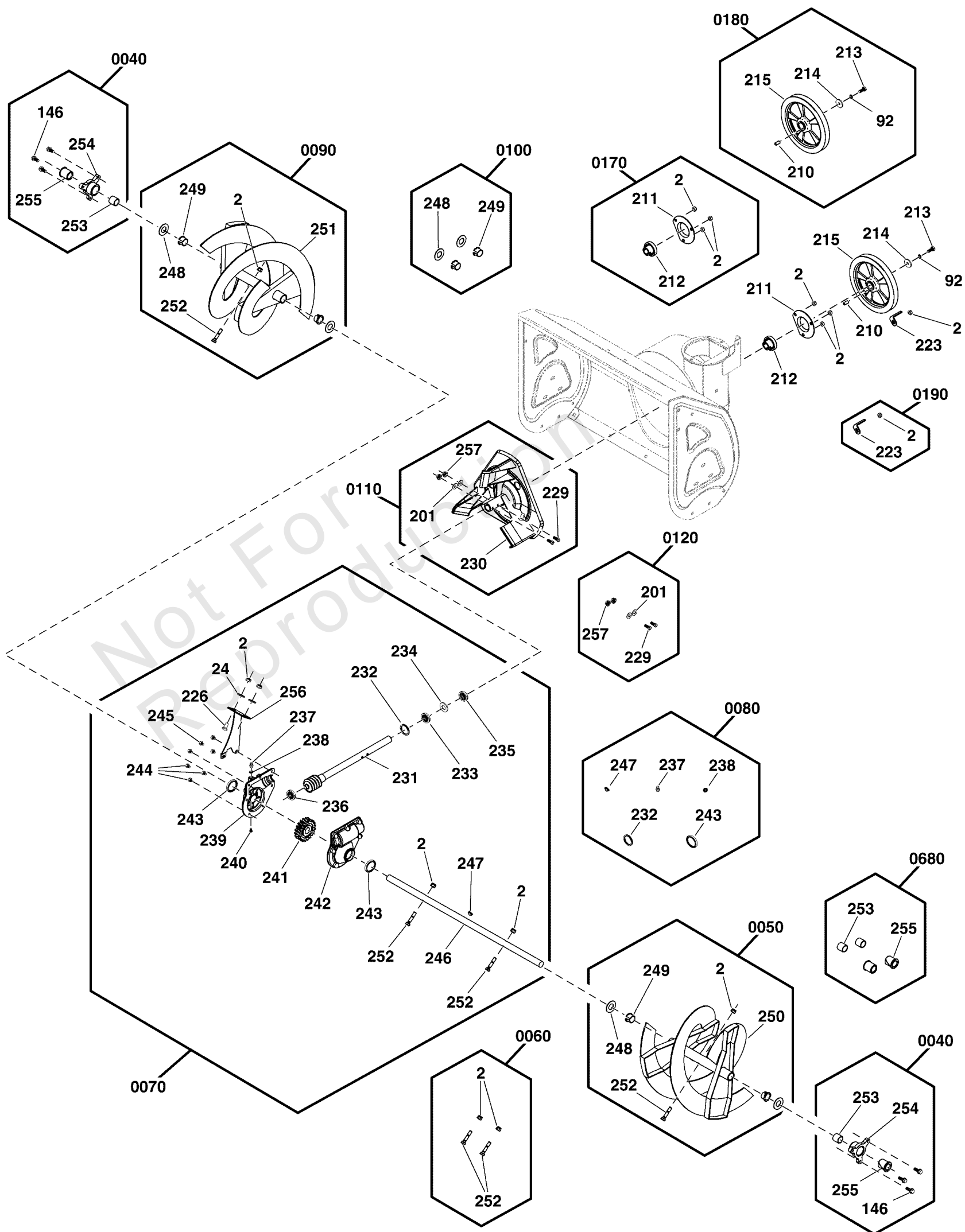

Auger Drive Group

REF NO	PART NO	QTY	DESCRIPTION
249	-----	2	BEARING, Auger Shaft
251	-----	1	AUGER, 24", Right, Black
252	-----	1	BOLT, Hex, M8 X 38
0100	707554	2	KIT, Auger Shaft Hardware -(Incl. Ref. Nos. 248, 249)
248	-----	2	WASHER, Flat
249	-----	2	BEARING, Auger Shaft
0110	707560	1	KIT, Impeller Assembly -(Incl. Ref. Nos. 201, 229, 230, 257)
201	-----	2	WASHER, 6x12x.7, Flat
229	-----	2	BOLT, Hex, M6 X 38
230	-----	1	IMPELLER
257	-----	2	NUT, Lock, M6
0120	707561	1	KIT, Shear Pin, Impeller -(Incl. Ref. Nos. 201, 229, 257)
201	-----	2	WASHER, 6x12x.7, Flat
229	-----	2	BOLT, Hex, M6 X 38
257	-----	2	NUT, Lock, M6
0170	770800	1	KIT, Bearing Hardware, Auger Pulley -(Incl. Ref. Nos. 2, 211, 212)
2	-----	3	NUT, Lock, M8
211	-----	1	RETAINER, Ball Bearing
212	-----	1	BEARING, Ball
0180	770803	1	KIT, Auger Pulley -(Incl. Ref. Nos. 92, 210, 213, 214, 215)
92	-----	1	WASHER, Lock, M8
210	-----	1	KEY, Flat, 6 X 6 X 17
213	-----	1	SCREW, Hex Head, M8X20
214	-----	1	WASHER, Flat, 8 X 28 X 3
215	-----	1	PULLEY
0190	707547	1	KIT, BELT GUIDE, AUGER -(Incl. Ref. Nos. 2, 223)
2	-----	1	NUT, Lock, M8
223	-----	1	GUIDE, Belt
0680	707552	2	KIT, Bearing, Mounting Plate -(Incl. Ref. Nos. 253, 255)
253	-----	2	BEARING, Sleeve
255	-----	2	BEARING, Auger Shaft

Auger Housing Group

Note: Unless noted otherwise, use the standard torque specifications

Mfg. No: 1696811-02

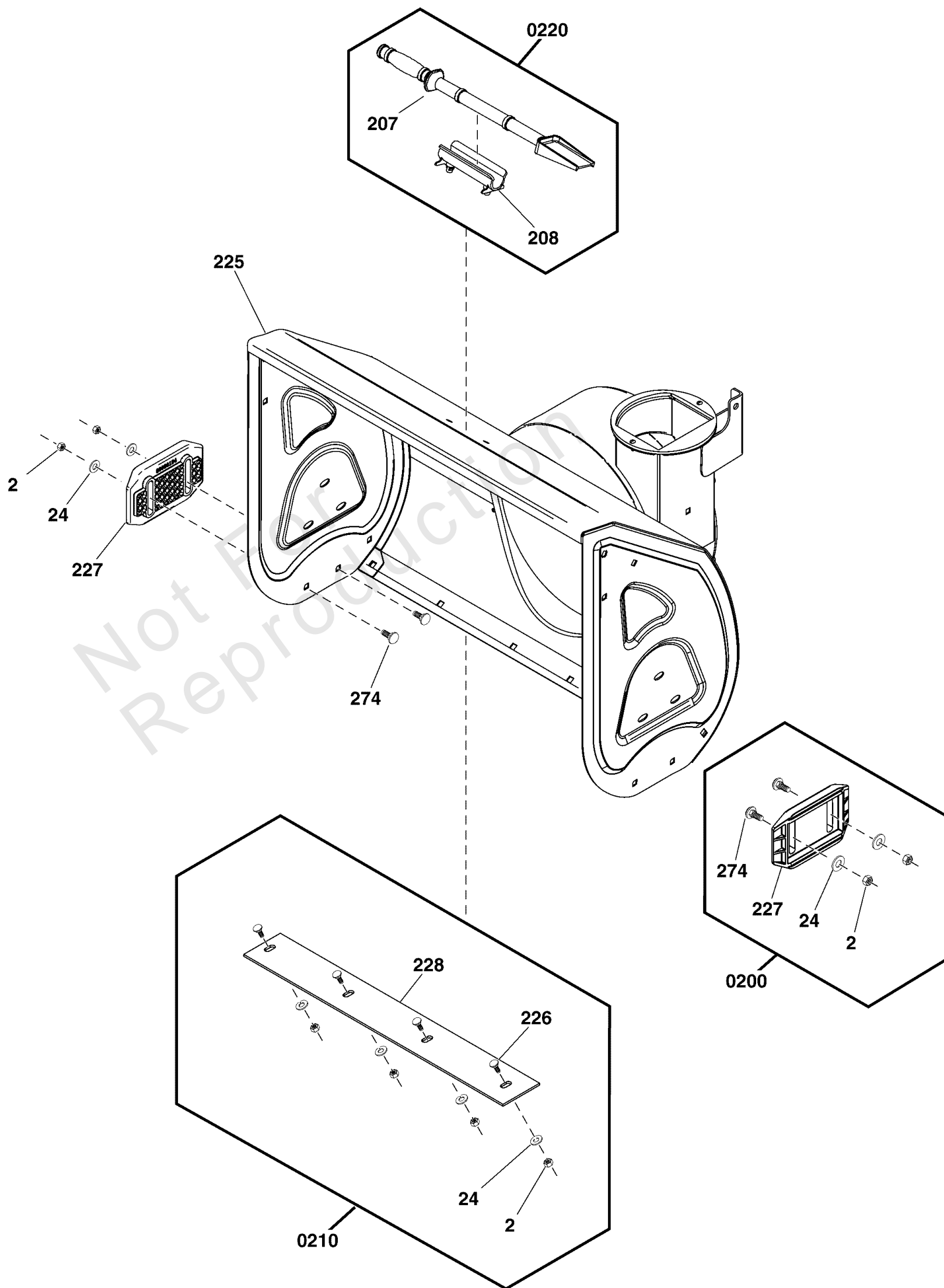

Auger Housing Group

REF NO	PART NO	QTY	DESCRIPTION
225	-----	1	AUGER HOUSING, 24", Orange -(Refer to Note:*)
0200	84003710	1	KIT, SKID SHOE -(Incl. Ref. Nos. 18, 75, 172, 173)
2	-----	4	NUT, Lock, M8
24	-----	4	WASHER, 8x22x2, Flat
274	-----	4	BOLT, Carriage, M8 X 25
227	-----	2	SHOE, Skid, Reversible
0210	84003707	1	KIT, Scraper Bar -(Incl. Ref. Nos. 18, 75, 170, 171)
2	-----	4	NUT, Lock, M8
24	-----	4	WASHER, 8x22x2, Flat
226	-----	4	BOLT, Carriage, M8 X 18
228	-----	1	BLADE, Scraper, 24"
0220	707549	1	KIT, CLEANOUT BRUSH STICK -(Incl. Ref. Nos. 207, 208)
207	-----	1	SHOVEL, Cleanout
208	-----	1	CLAMP, Cleanout

Not For
Reproduction

Footnotes:

Note:* Not a serviceable part.

Controls Group

Note: Unless noted otherwise, use the standard torque specifications

Mfg. No: 1696811-02

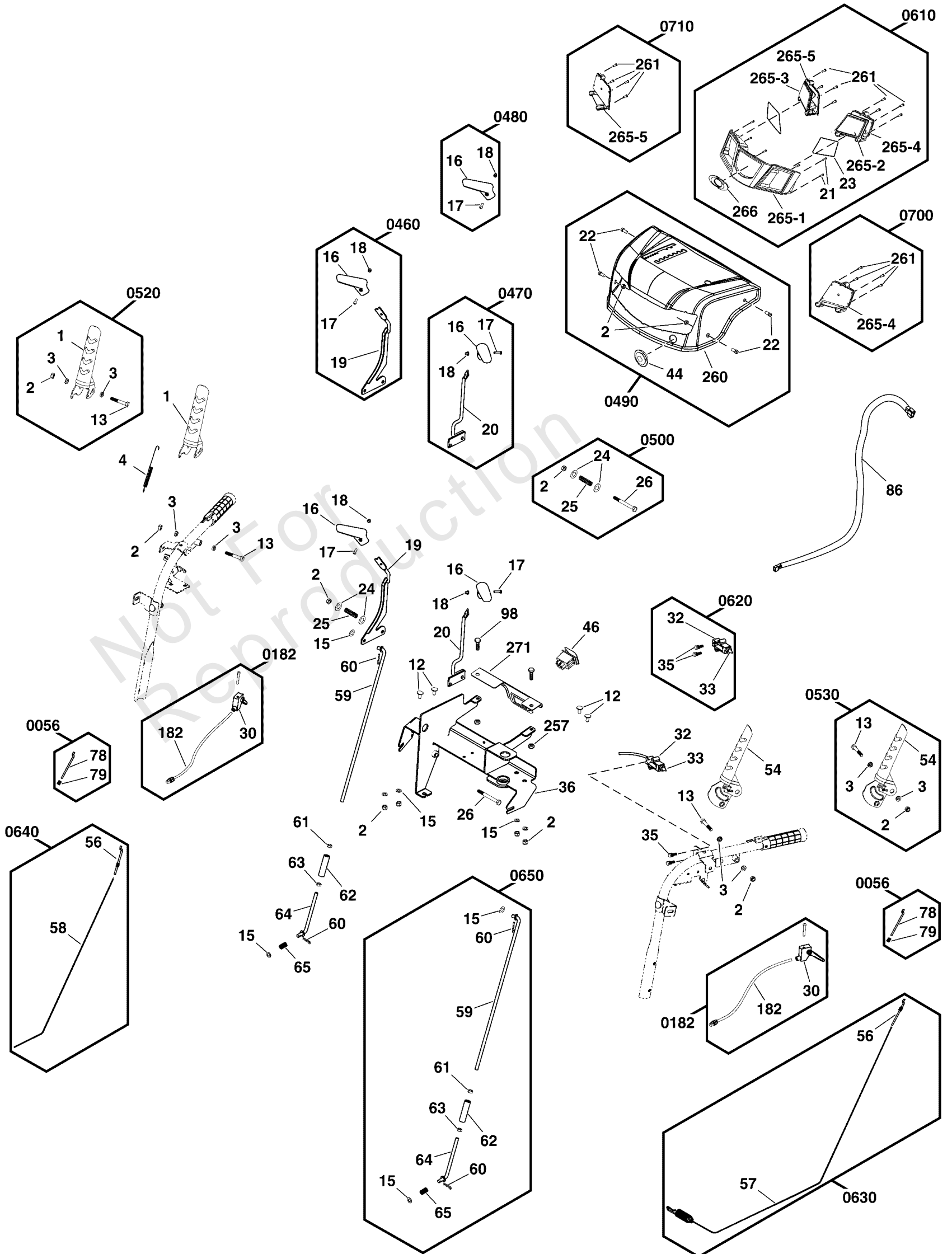

Controls Group

REF NO	PART NO	QTY	DESCRIPTION
4	707877	1	SPRING, Handle
12	-----	4	BOLT, Carriage, M8 X 16
36	-----	1	PANEL, Dash
46	770770	1	SWITCH
86	770788	1	HARNESS, Wiring
	-----	1	FUSE, GMA-3-R, 3A 250V -(Refer to your local hardware store for replacement fuses.)
98	-----	6	SCREW, Hex Head W/ Flat Washer, M6 X 12
257	-----	5	NUT, Lock, M6
271	-----	1	BRACKET, Switch
0056	770785	2	KIT, Cable, Hardware -(Incl. Ref. Nos. 78, 79)
78	-----	1	ROD, Cable
79	-----	1	NUT, Copper
0182	771703	2	CABLE, Steering -(Incl. Ref. Nos. 30, 182)
30	-----	1	LEVER, Steering Control Assembly
182	-----	1	CABLE, Clutch
0460	770813	1	KIT, Lever, Speed -(Incl. Ref. Nos. 16, 17, 18, 19)
16	-----	1	KNOB, Slot Speed
17	-----	1	SCREW, Phillips Head, M5
18	-----	1	NUT, Acorn, M5
19	-----	1	LEVER ASSEMBLY, Speed
0470	770830	1	KIT, Lever, Discharge Chute -(Incl. Ref. Nos. 16, 17, 18, 20)
16	-----	1	KNOB, Slot Speed
17	-----	1	SCREW, Phillips Head, M5
18	-----	1	NUT, Acorn, M5
20	-----	1	LEVER ASSEMBLY, Deflector
0480	770834	1	KIT, Knob, Lever -(Incl. Ref. Nos. 16, 17, 18)
16	-----	1	KNOB, Slot Speed
17	-----	1	SCREW, Phillips Head, M5
18	-----	1	NUT, Acorn, M5
0490	770808	1	ASSEMBLY, Dash -(Incl. Ref. Nos. 2, 22, 44, 264)
2	-----	4	NUT, Lock, M8
22	-----	4	SCREW, Hex Flange Head, M8 X 16
44	-----	1	BUSHING, Rotation Rod, Dash
260	-----	1	PANEL, Orange
0500	707507	1	KIT, Hardware, Speed & Discharge -(Incl. Ref. Nos. 2, 24, 25, 26)
2	-----	1	NUT, Lock, M8
24	-----	2	WASHER, 8x22x2, Flat
25	-----	1	SPRING, Lever Assembly
26	-----	1	SCREW, Hex Head, M8 X 70
0520	770771	1	KIT, Right Hand Lever (Traction Drive) -(Incl. Ref. Nos. 1, 2, 3, 13)
1	-----	1	LEVER, Clutch, Right
2	-----	1	NUT, Lock, M8
3	-----	2	SPACER, Idler Plate, Small
13	-----	1	SCREW, Hex Head, M8 X 60
0530	770772	1	KIT, Left Hand Lever (Auger Drive) -(Incl. Ref. Nos. 2, 3, 13, 54)

Controls Group

Note: Unless noted otherwise, use the standard torque specifications

Mfg. No: 1696811-02

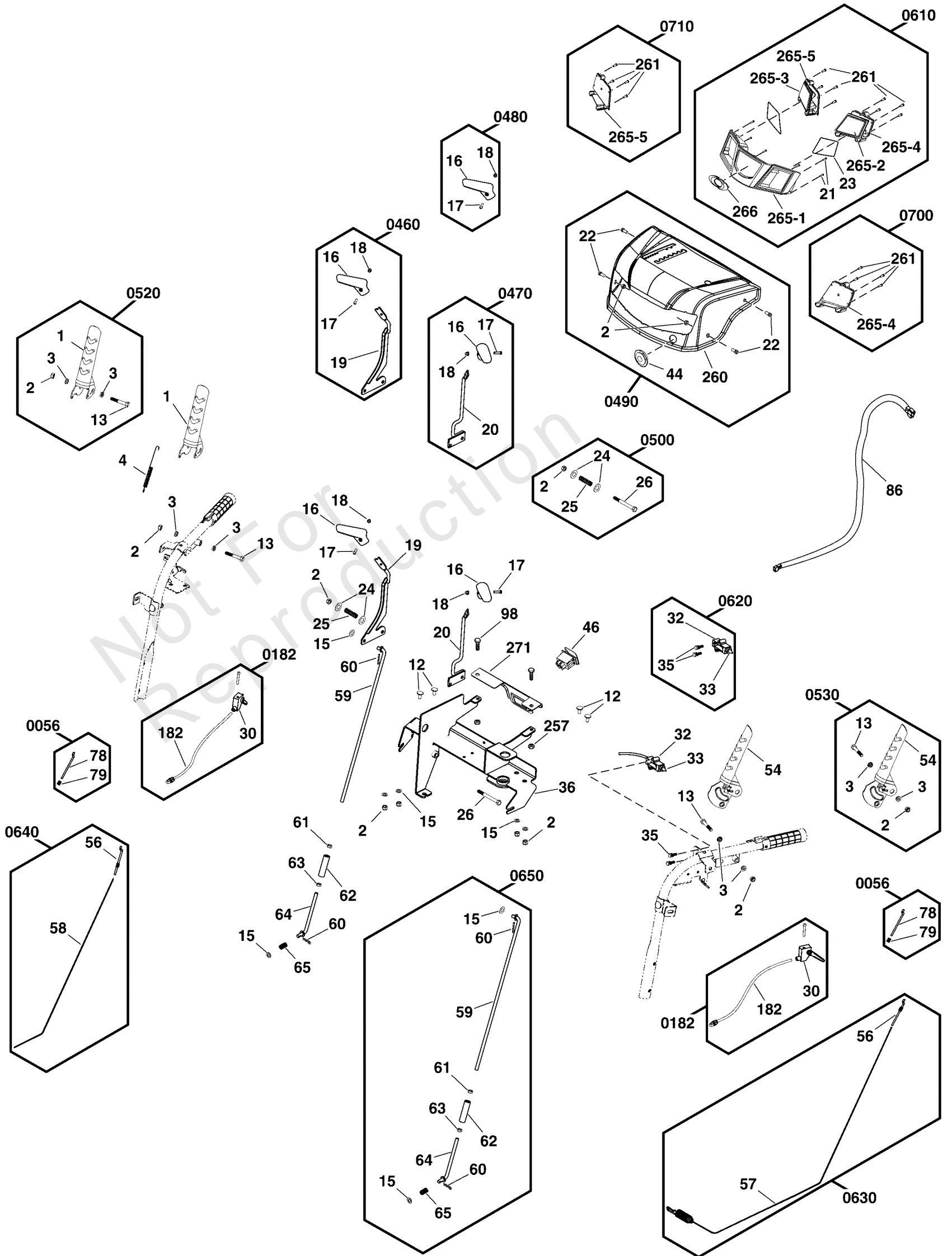

Controls Group

REF NO	PART NO	QTY	DESCRIPTION
2	-----	1	NUT, Lock, M8
3	-----	2	SPACER, Idler Plate, Small
13	-----	1	SCREW, Hex Head, M8 X 60
54	-----	1	LEVER, Clutch, Left
0610	770782	1	KIT, Headlight -(Incl. Ref. Nos. 21, 23, 261, 265-1, 265-2, 265-3, 265-4, 265-5, 266)
21	-----	6	SCREW, Phillips Head, ST4, 2 X 14
23	-----	2	O-RING, 1.4 X 87.5
261	-----	8	SCREW, Phillips Head, Self Tapping, ST2.9 X 14
265-1	-----	1	HOUSING, Light
265-2	-----	1	LENS, Light, Left
265-3	-----	1	LENS, Light, Right
265-4	-----	1	LIGHT ASSEMBLY, Left
265-5	-----	1	LIGHT ASSEMBLY, Right
266	1755798YP	1	DECAL, 3D, Logo, Simplicity
0620	707521	1	KIT, Free Hand Control Assembly -(Incl. Ref. Nos. 32, 33, 35)
32	-----	1	BODY, Free Hand Control
33	-----	1	CABLE, Free Hand Control
35	-----	2	SCREW, Hex Head, W/ Lock Washer, M6 X 20
0630	770784	1	KIT, Cable, Auger Drive -(Incl. Ref. Nos. 56, 57)
56	-----	1	KIT, Cable Hardware
57	-----	1	CABLE, Auger Drive
0640	770786	1	KIT, Cable, Traction Drive -(Incl. Ref. Nos. 56, 58)
56	-----	1	KIT, Cable Hardware
58	-----	1	CABLE, Traction Drive
0650	770787	1	KIT, Traction Drive Rod -(Incl. Ref. Nos. 15, 59, 60, 61, 62, 63, 64, 65)
15	-----	2	WASHER, Flat, 8 X 16 X 1.2
59	-----	1	ROD, Speed Select, Upper
60	-----	2	PIN, Hair, Cotter
61	-----	1	NUT, Hex, M8
62	-----	1	SLEEVE, Adjustment, M8
63	-----	1	NUT, Hex, M8
64	-----	1	ROD, Speed Select, Lower
65	-----	1	SPRING, Speed Select
0700	772141	1	KIT, Light Assembly, Left -(Incl. Ref. Nos. 261, 265-4)
261	-----	4	SCREW, Phillips Head, Self Tapping, ST2.9 X 14
265-4	-----	1	LIGHT ASSEMBLY, Left
0710	772142	1	KIT, Light Assembly, Right -(Incl. Ref. Nos. 261, 265-5)
261	-----	4	SCREW, Phillips Head, Self Tapping, ST2.9 X 14
265-5	-----	1	LIGHT ASSEMBLY, Right

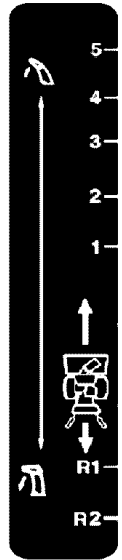
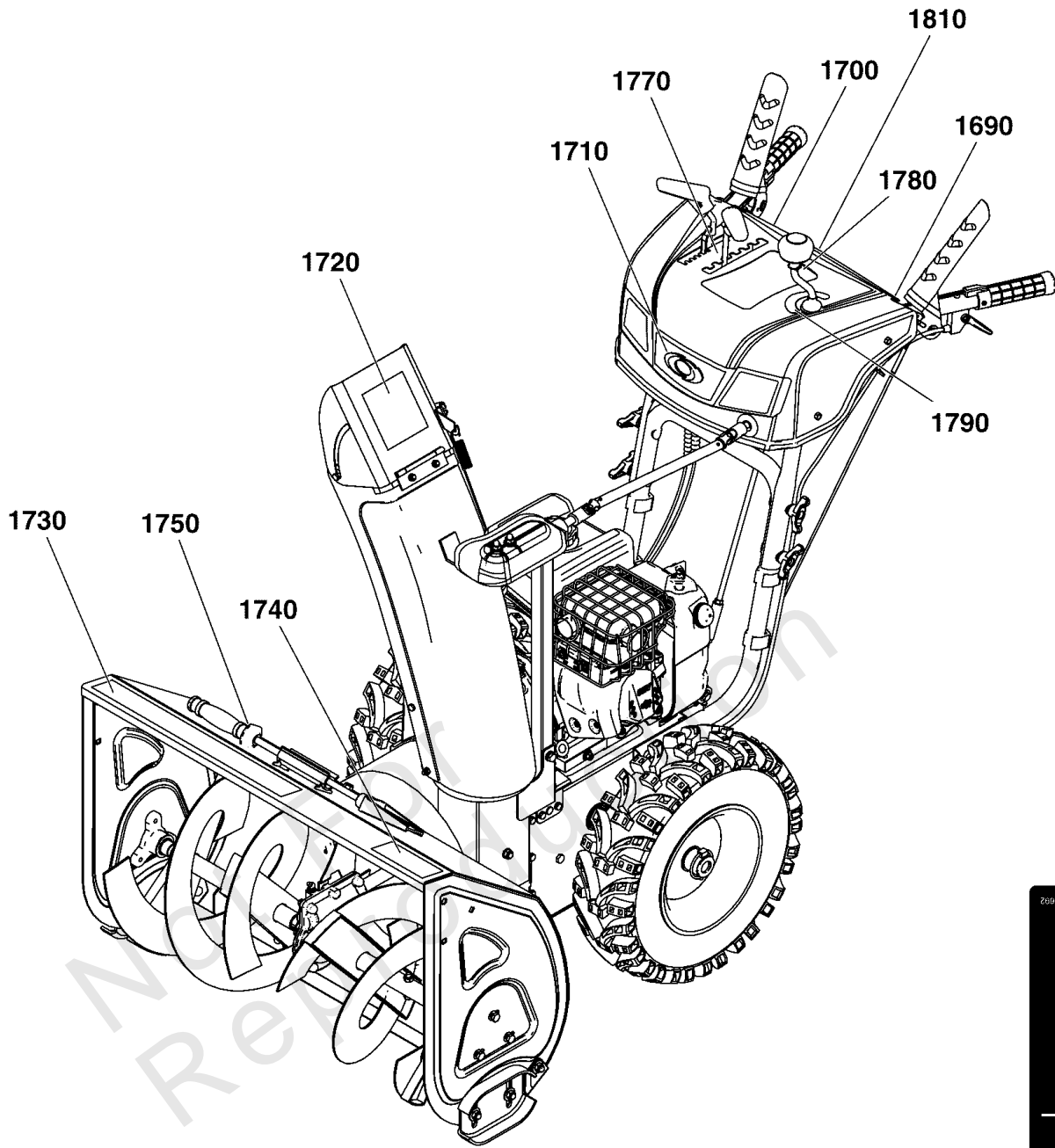

1770

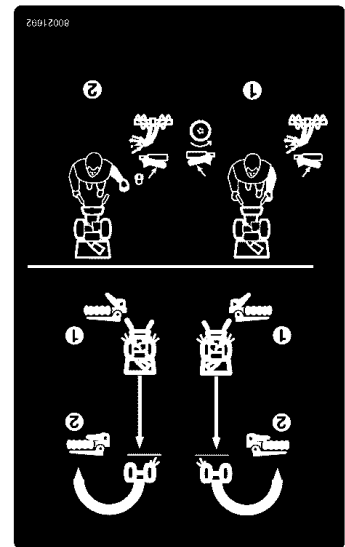

1780

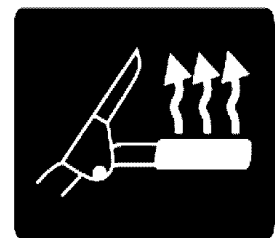

1810



1710

SELECT1024

1740



1790

Simplicity

1730

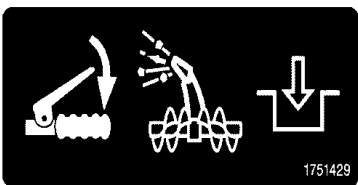

1690

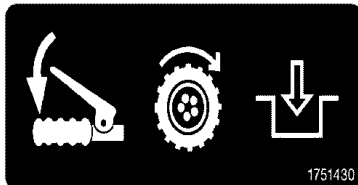

1700



1720

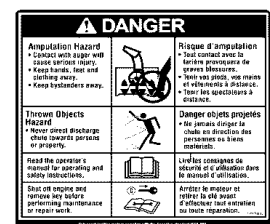

1750

Decals Group

REF NO	PART NO	QTY	DESCRIPTION
1690	771843	1	DECAL, Auger Control
1700	771844	1	DECAL, Traction Control
1710	1755798YP	1	DECAL, 3D, Logo, Simplicity
1720	1737865YP	1	DECAL, Danger Chute Warning, FR/ENG
1730	1757673YP	1	DECAL, SMI LOGO 10.47
1740	84003637	1	DECAL, Model
1750	1737866YP	1	DECAL, Danger Foot, FR/ENG
1770	771859	1	DECAL, 1-6 Transmission Speed Control
1780	771860	1	DECAL, Free Hand Operation
1790	771861	1	DECAL, Chute Rotation
1810	771862	1	DECAL, Heated Hand Grip Switch

Not For Reproduction

Discharge Chute Group

Note: Unless noted otherwise, use the standard torque specifications

Mfg. No: 1696811-02

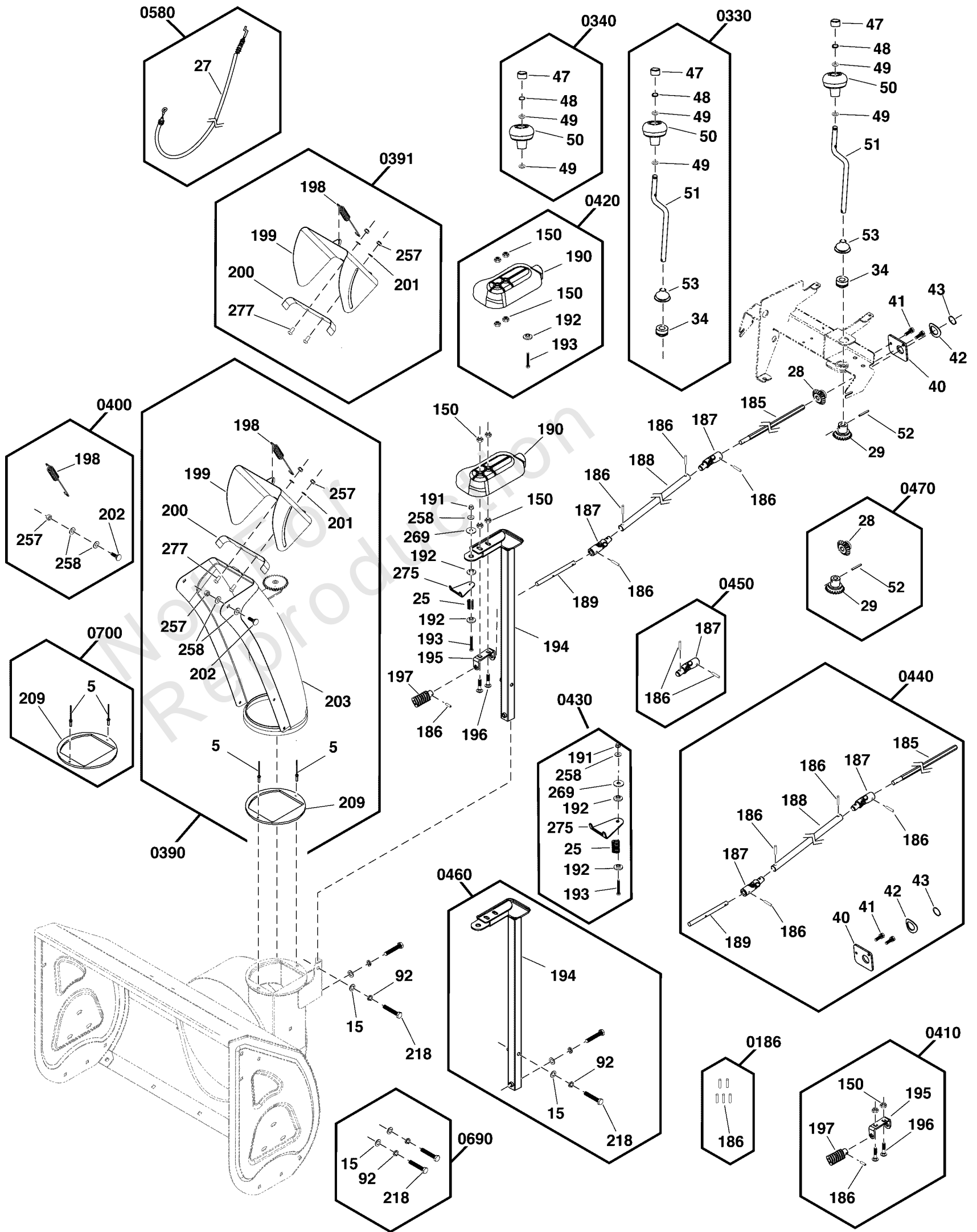

Discharge Chute Group

REF NO	PART NO	QTY	DESCRIPTION
0186	771921	1	KIT, Spring Pin, 4 X 20 -(Incl. Ref. No. 186)
186	-----	5	PIN, 4 X 20, Spring
0330	707503	1	KIT, Chute Rotation -(Incl. Ref. Nos. 34, 47, 48, 49, 50, 51, 53)
34	-----	1	BUSHING, Rotation Rod
47	-----	1	KNOB, Cover
48	-----	1	RING, External Retaining, 10
49	-----	2	WASHER, Flat, 10 X 20 X 1
50	-----	1	KNOB, Chute Rotator
51	-----	1	ROD, Chute Rotation
53	-----	1	BUSHING, Chute Rotation
0340	707502	1	KIT, Chute Knob -(Incl. Ref. Nos. 47, 48, 49, 50)
47	-----	1	KNOB, Cover
48	-----	1	RING, External Retaining, 10
49	-----	2	WASHER, Flat, 10 X 20 X 1
50	-----	1	KNOB, Chute Rotator
0390	84004823	1	KIT, Chute Assembly, Orange -(Incl. Ref. Nos. 5, 198, 199, 200, 201, 202, 203, 209, 257, 258, 277)
5	-----	2	RIVET, 4 X 13
198	-----	1	SPRING, Extension
199	-----	1	DEFLECTOR, Chute, Orange
200	-----	1	GASKET, Chute Deflector
201	-----	2	WASHER, 6x12x.7, Flat
202	-----	1	SCREW, Shoulder, M6 X 10
203	80083436		CHUTE, Orange
209	-----	1	ADAPTER, Chute Ring
257	-----	3	NUT, Lock, M6
258	-----	2	WASHER, 6 X 18 X 1.5, Flat
277	-----	2	BOLT, Button Head Socket, M6 X 13
0391	1688077	1	KIT, Chute Deflector -(Incl. Ref. Nos. 198, 199, 200, 201, 257, 277)
198	-----	1	SPRING, Extension
199	-----	1	DEFLECTOR, Chute, Orange
200	-----	1	GASKET, Chute Deflector
201	-----	2	WASHER, 6x12x.7, Flat
257	-----	2	NUT, Lock, M6
277	-----	2	BOLT, Button Head Socket, M6 X 13
0400	707563	1	KIT, Spring, Chute -(Incl. Ref. Nos. 198, 202, 257, 258)
198	-----	1	SPRING, Extension
202	-----	1	SCREW, Shoulder, M6 X 10
257	-----	1	NUT, Lock, M6
258	-----	2	WASHER, 6 X 18 X 1.5, Flat
0410	707543	1	KIT, Worm Gear Hardware, Chute -(Incl. Ref. Nos. 150, 186, 195, 196, 197)
150	-----	2	NUT, Hex Flange Head, M8
186	-----	1	PIN, 4 X 20, Spring
195	-----	1	BRACKET, Chute Rotation, Worm
196	-----	2	BOLT, Carriage, M8 X 30
197	-----	1	GEAR, Chute Rotation, Worm
0420	84003878	1	KIT, Cover, Chute Rotation -(Incl. Ref. Nos. 150, 190, 192, 193)

Discharge Chute Group

Note: Unless noted otherwise, use the standard torque specifications

Mfg. No: 1696811-02

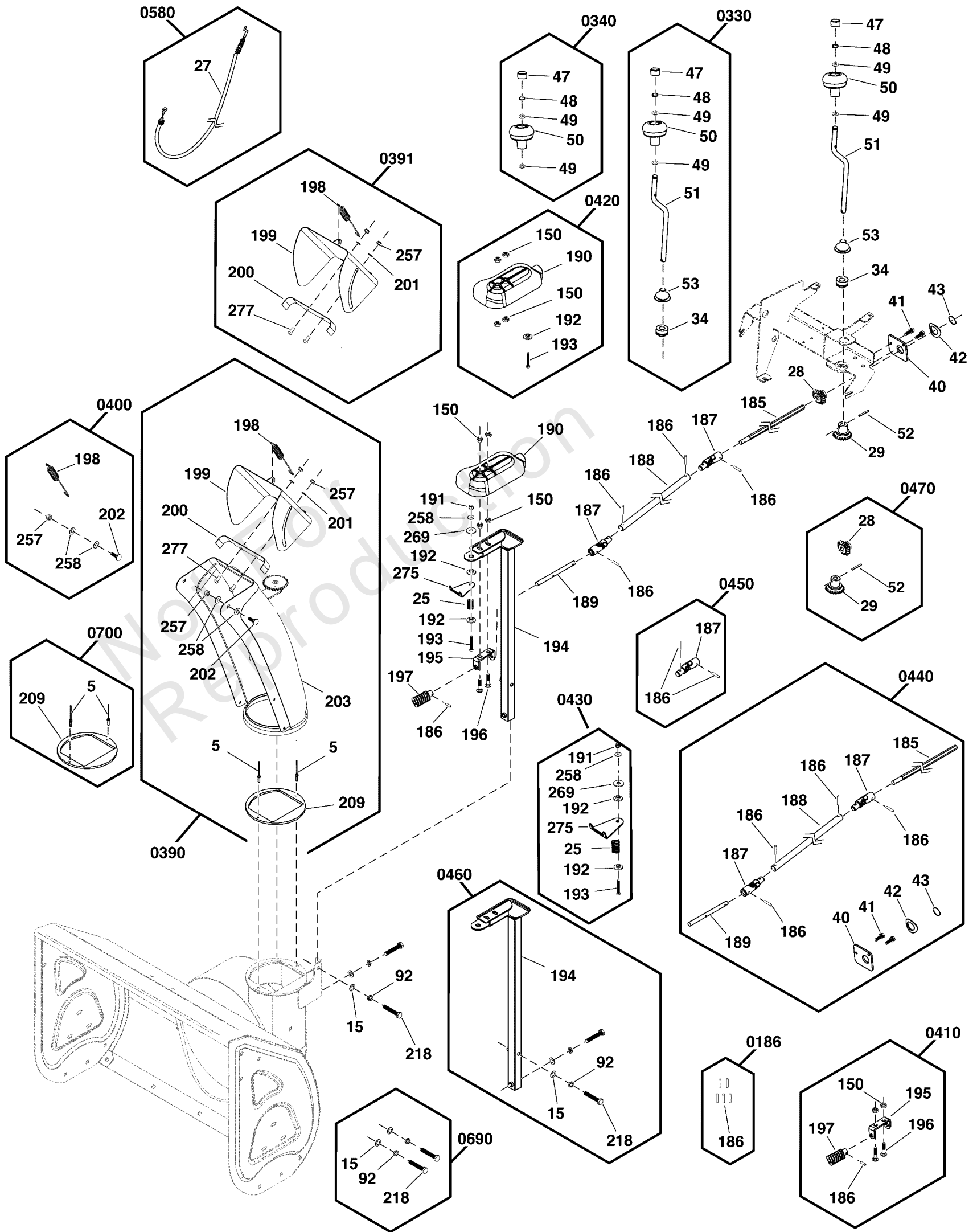

Discharge Chute Group

REF NO	PART NO	QTY	DESCRIPTION
150	-----	4	NUT, Hex Flange Head, M8
190	-----	1	COVER, Chute Rotation
192	-----	1	SPACER, Chute Rotation Bracket
193	-----	1	SCREW, Hex Head, M6 X 70
0430	1688079	1	KIT, Chute Rotation -(Incl. Ref. Nos. 25, 191, 192, 193, 258, 269, 275)
25	-----	1	SPRING, Lever Assembly
191	-----	1	NUT, Lock, Hex Flange Head, M6
192	-----	1	SPACER, Chute Rotation Bracket
193	-----	1	SCREW, Hex Head, M6 X 70
258	-----	1	WASHER, 6 X 18 X 1.5, Flat
269	-----	1	WASHER, Rubber
275	-----	1	BRACKET, Chute Rotation
0440	771895	1	KIT, Chute Rotation Rod -(Incl. Ref. Nos. 40, 41, 42, 43, 185, 186, 187, 188, 189)
40	-----	1	PLATE, Rotation Rod, Bevel Gear
41	-----	2	SCREW, Hex Head, M6 X 20
42	-----	1	WASHER, Wave, 20
43	-----	1	RING, External Retaining, 20
185	-----	1	ROD, Chute Rotation, Driven
186	-----	4	PIN, 4 X 20, Spring
187	-----	2	UNIVERSAL JOINT
188	-----	1	ROD, Chute Rotation, Connecting
189	-----	1	ROD, Chute Rotation, Worm
0450	707524	2	KIT, Cardan Joint -(Incl. Ref. Nos. 186, 187)
186	-----	2	PIN, 4 X 20, Spring
187	-----	1	UNIVERSAL JOINT
0460	771864	1	KIT, Chute Rotation Bracket -(Incl. Ref. Nos. 15, 92, 194, 218)
15	-----	2	WASHER, Flat, 8 X 16 X 1.2
92	-----	2	WASHER, Lock, M8
194	-----	1	BRACKET, Chute Rotation Upper
218	-----	2	SCREW, Hex Head, M8 X 45
0470	770774	1	KIT, Bevel Gear, Chute Rotation -(Incl. Ref. Nos. 28, 29, 52)
28	-----	1	GEAR, Bevel
29	-----	1	GEAR, Bevel
52	-----	1	PIN, Spring, 4 X 28
0580	771734	1	KIT, Cable-Chute Deflector -(Incl. Ref. No. 27)
27	-----	1	CABLE, Deflector Control
0690	771996	1	KIT, Bracket, Chute Rotation Hardware -(Incl. Ref. Nos. 15, 92, 218)
15	-----	2	WASHER, Flat, 8 X 16 X 1.2
92	-----	2	WASHER, Lock, M8
218	-----	2	SCREW, Hex Head, M8 X 45
0700	84002905	1	KIT, Hardware, Chute Rotation -(Incl. Ref. Nos. 5, 209)
5	-----	2	RIVET, 4 X 13
209	-----	1	ADAPTER, Chute Ring

Engine & Frame Group

Note: Unless noted otherwise, use the standard torque specifications

Mfg. No: 1696811-02

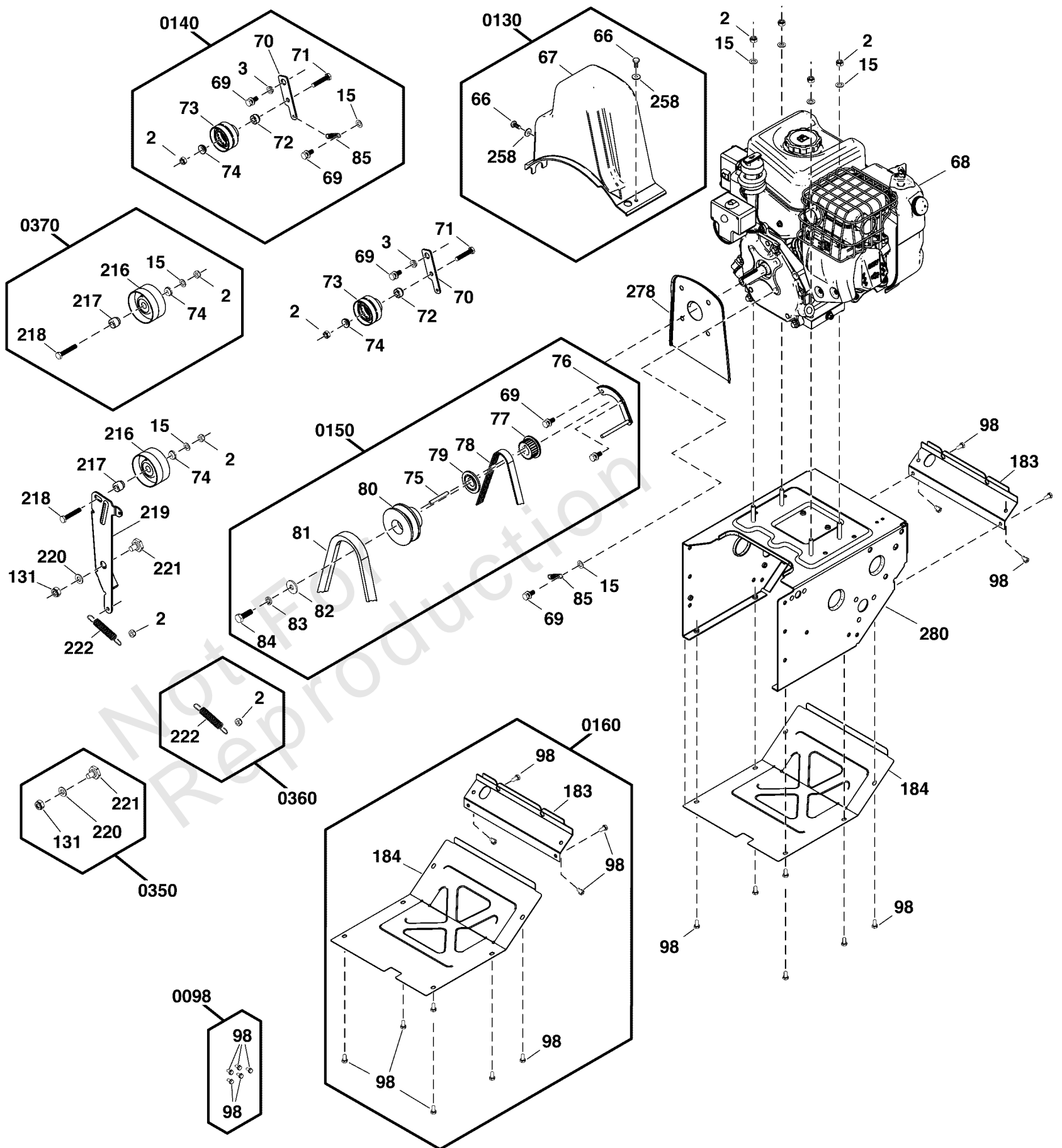

Engine & Frame Group

REF NO	PART NO	QTY	DESCRIPTION
68	13A137-0019-F1	1	*ENGINE, Briggs & Stratton -(Engine Model: 13A137-0019-F1) (Refer to Note: *)
219	770804	1	IDLER, Auger
278	1688080	1	KIT, WATER SHIELD, 208CC
280	-----	1	MOTOR BOX ASSEMBLY, Orange -(Refer to Note: **)
0098	771904	6	KIT, Hardware -(Incl. Ref. No. 98)
98	-----	5	SCREW, Hex Head W/ Flat Washer, M6 X 12
0130	770791	1	KIT, Belt Cover -(Incl. Ref. Nos. 66, 67, 258)
66	-----	2	SCREW, Hex Head, M6 X 12
67	-----	1	COVER, Belt
258	-----	2	WASHER, 6 X 18 X 1.5, Flat
0140	707836	1	KIT, IDLER PULLEY, TRACTION DRIVE -(Incl. Ref. Nos. 2, 3, 15, 69, 70, 71, 72, 73, 74, 85)
2	-----	1	NUT, Lock, M8
3	-----	1	SPACER, Idler Plate, Small
15	-----	1	WASHER, Flat, 8 X 16 X 1.2
69	-----	2	SCREW, Hex Flange Head, M8 X 20
70	-----	1	BRACKET, Idler
71	-----	1	SCREW, Hex Head, M8 X 40
72	-----	1	SPACER, Idler Pulley
73	-----	1	PULLEY, Idler
74	-----	1	SPACER, Idler Pulley
85	-----	1	SPRING, Idler
0150	770816	1	KIT, Idler Pulley, Traction Drive -(Incl. Ref. Nos. 69, 75, 76, 77, 78, 79, 80, 81, 82, 83, 84)
69	-----	2	SCREW, Hex Flange Head, M8 X 20
75	84004762	1	KEY, Flat, 5 X 4.7 X 50
76	-----	1	GUIDE, Belt
77	-----	1	PULLEY, Drive
78	707585	1	BELT, Traction Drive
79	-----	1	SPACER, Belt Wheel
80	-----	1	PULLEY, Auger
81	770796	1	BELT, Auger Drive
82	-----	1	SPACER
83	-----	1	WASHER, M10, Split Lock
84	-----	1	SCREW, Hex Head, M10 X 30
0160	770819	1	KIT, Bottom Cover -(Incl. Ref. Nos. 98, 183, 184)
98	-----	10	SCREW, Hex Head W/ Flat Washer, M6 X 12
183	-----	1	COVER, Back, Orange
184	-----	1	COVER, Bottom, Orange
0350	707565	1	KIT-HARDWARE, IDLER BRACKET -(Incl. Ref. Nos. 131, 220, 221)
131	-----	1	NUT, Lock, M10
220	-----	1	WASHER, Flat, 10 X 20 X 2
221	-----	1	SCREW, Hex Head, M10 X 13
0360	770806	1	SPRING, Idler Pulley -(Incl. Ref. Nos. 2, 222)

Footnotes:

Note:** Not a serviceable part.

Note:* Refer to your local Briggs & Stratton distributor for parts and service.

Engine & Frame Group

Note: Unless noted otherwise, use the standard torque specifications

Mfg. No: 1696811-02

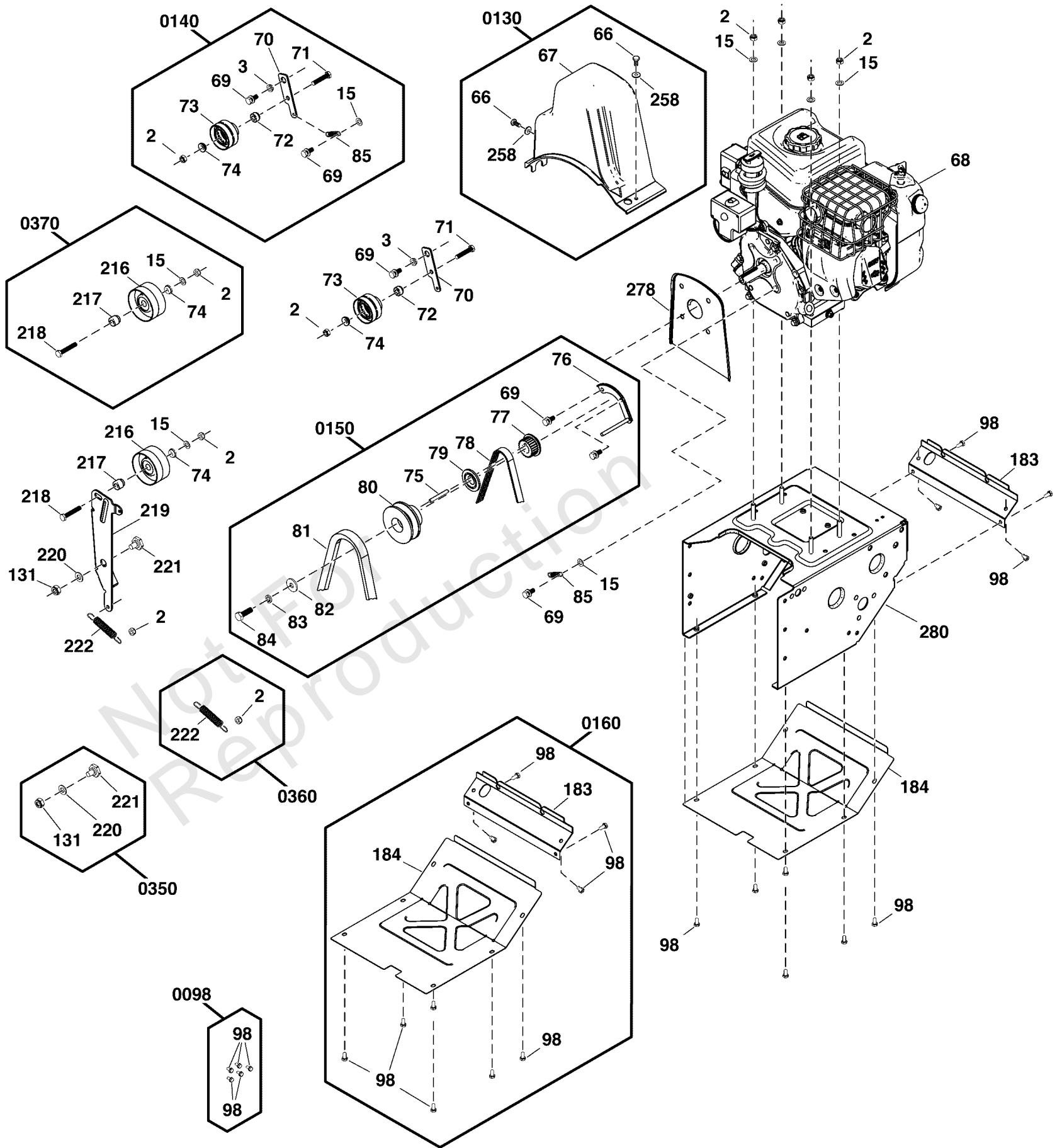

Engine & Frame Group

REF NO	PART NO	QTY	DESCRIPTION
2	-----	1	NUT, Lock, M8
222	-----	1	SPRING, Idler
0370	770807	1	KIT, Idler Pulley, Tension Plate -(Incl. Ref. Nos. 2, 15, 74, 216, 217, 218)
2	-----	1	NUT, Lock, M8
15	-----	1	WASHER, Flat, 8 X 16 X 1.2
74	-----	1	SPACER, Idler Pulley
216	-----	1	PULLEY, Idler
217	-----	1	SPACER, Sleeve, Idler Pulley
218	-----	1	SCREW, Hex Head, M8 X 45

Not For
Reproduction

Footnotes:

Note:** Not a serviceable part.

Note:* Refer to your local Briggs & Stratton distributor for parts and service.

Handles Group

REF NO	PART NO	QTY	DESCRIPTION
0510	770769	1	KIT, Grip, Handle -(Incl. Ref. Nos. 55, 270)
55	-----	2	HAND GRIP, Heated, 60W
270	-----	4	SCREW #6-20X0.380 SELFDRILL PAN HD ZC/CL
0550	707513	2	KIT, Wing Knob, Handle -(Incl. Ref. Nos. 88, 89, 90)
88	-----	2	KNOB, Wing, M8
89	-----	2	WASHER, M8, Curved
90	-----	2	BOLT, Carriage, M8 X 55
0560	770776	1	KIT, Upper Handle, Left -(Incl. Ref. Nos. 2, 12, 15, 37, 39, 88, 89, 90, 150, 267)
2	-----	2	NUT, Lock, M8
12	-----	2	BOLT, Carriage, M8 X 16
15	-----	2	WASHER, Flat, 8 X 16 X 1.2
37	-----	1	HANDLE, Upper Left
39	-----	1	BRACKET, Mounting, Dash, Left
88	-----	1	KNOB, Wing, M8
89	-----	2	WASHER, M8, Curved
90	-----	1	BOLT, Carriage, M8 X 55
150	-----	1	NUT, Hex Flange Head, M8
267	-----	1	BOLT, M8x40, Carriage, Curved Head
0570	770778	1	KIT, Upper Handle, Right -(Incl. Ref. Nos. 2, 12, 14, 15, 38, 88, 89, 90, 150, 267)
2	-----	2	NUT, Lock, M8
12	-----	2	BOLT, Carriage, M8 X 16
14	-----	1	HANDLE, Upper Right
15	-----	2	WASHER, Flat, 8 X 16 X 1.2
38	-----	1	BRACKET, Mounting, Dash, Right
88	-----	1	KNOB, Wing, M8
89	-----	2	WASHER, M8, Curved
90	-----	1	BOLT, Carriage, M8 X 55
150	-----	1	NUT, Hex Flange Head, M8
267	-----	1	BOLT, M8x40, Carriage, Curved Head
0590	770780	2	KIT, Lower Handle Hardware -(Incl. Ref. Nos. 15, 91, 92)
15	-----	2	WASHER, Flat, 8 X 16 X 1.2
91	-----	2	SCREW, Hex Head, M8 X 40
92	-----	2	WASHER, Lock, M8
0600	770781	1	KIT, Lower Handle -(Incl. Ref. Nos. 15, 87, 88, 89, 90, 91, 92, 276)
15	-----	4	WASHER, Flat, 8 X 16 X 1.2
87	-----	1	HANDLE, Lower
88	-----	4	KNOB, Wing, M8
89	-----	4	WASHER, M8, Curved
90	-----	4	BOLT, Carriage, M8 X 55
91	-----	4	SCREW, Hex Head, M8 X 40
92	-----	4	WASHER, Lock, M8
276	-----	4	CLAMP, Cable Guide
0680	771930	2	KIT, Clamp, Cable Guide -(Incl. Ref. No. 276)
276	-----	2	CLAMP, Cable Guide

Transaxle Drive Group

Note: Unless noted otherwise, use the standard torque specifications

Mfg. No: 1696811-02

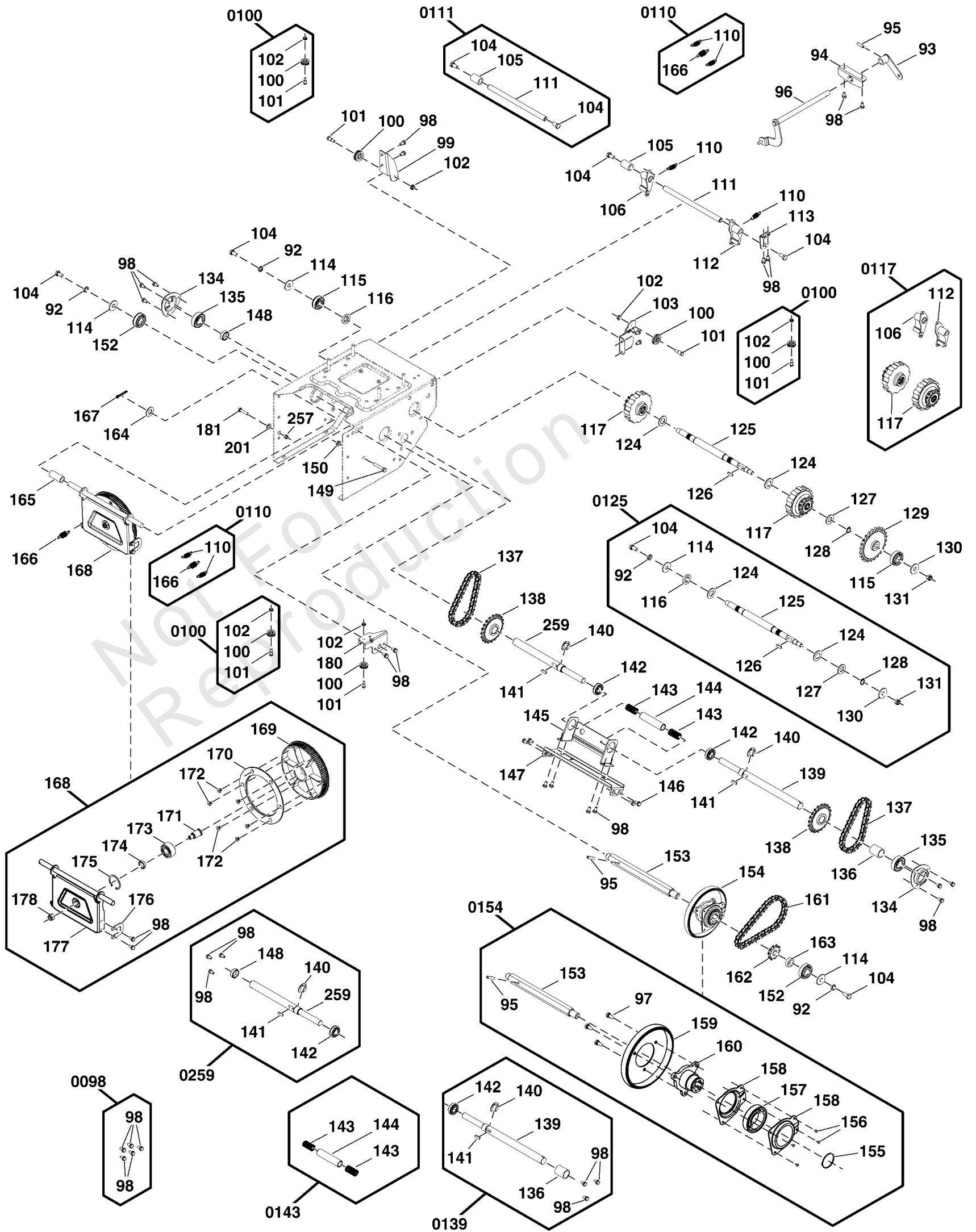

Transaxle Drive Group

REF NO	PART NO	QTY	DESCRIPTION
93	771916	1	ARM, Speed Select
94	771915	1	BRACKET, Speed Select
95	771912	2	PIN, Spring, 6 X 30
96	771913	1	ROD, Speed Select, Fork
99	771918	1	BRACKET, Cable Guide, Traction Control
103	771917	1	BRACKET, Cable Guide, Auger Control
113	-----	1	BRACKET, Pawl
115	771902	2	BEARING, Ball
129	771906	1	SPROCKET, 24T
134	771911	2	RETAINER, Ball Bearing
135	771901	2	BEARING, Ball
136	771914	1	SLEEVE, Drive Shaft
137	771907	2	CHAIN, Roller, 30
138	771908	2	SPROCKET, 20T
143	-----	2	SPRING, Drive Shaft
144	-----	1	SLEEVE, Drive Shaft
145	-----	1	BRACKET, Drive Shaft
146	-----	4	SCREW, Hex Head, M8 X 16
147	-----	1	PLATE, Drive Shaft Bracket
149	-----	1	SCREW, Hex Head, M8 X 50
150	-----	1	NUT, Hex Flange Head, M8
152	771900	2	BEARING, Ball
154	-----	1	FRICITION WHEEL ASSEMBLY
161	771910	1	CHAIN, Roller, 36
162	771909	1	SPROCKET, 10T
163	-----	1	BUSHING, Hex Shaft
164	-----	1	WASHER, Flat, 13 X 24 X 2
165	-----	1	SLEEVE, Spacer, Swinging Plate
167	-----	1	PIN, Cotter, 2.5 X 30
168	771905	1	ASSEMBLY, Friction Swinging Plate -(Incl. Ref. Nos. 98, 169, 170, 171, 172, 173, 174, 175, 176, 177, 178)
98	-----	2	SCREW, Hex Head W/ Flat Washer, M6 X 12
169	-----	1	PULLEY, Friction
170	-----	1	COVER, Friction Pulley
171	-----	1	SHAFT, Bearing Retainer, M10
172	-----	6	SCREW, Phillips Head, M6 X 10
173	-----	1	BEARING, Ball
174	-----	1	SLEEVE, Spacer, Swinging Plate
175	-----	1	RING, Internal Retaining, 40
176	-----	1	BRACKET, Swinging Plate
177	-----	1	PLATE, Swinging
178	-----	1	NUT, Lock, M10
180	-----	1	BRACKET, Cable Guide
181	-----	1	SCREW, Hex Head, M6 X 30
201	-----	1	WASHER, 6x12x.7, Flat
257	-----	1	NUT, Lock, M6
0098	771904	6	KIT, Hardware -(Incl. Ref. No. 98)
98	-----	5	SCREW, Hex Head W/ Flat Washer, M6 X 12
0100	707541	3	KIT, Pulley, Cable -(Incl. Ref. Nos. 100, 101, 102)
100	-----	1	PULLEY, Cable

Transaxle Drive Group

REF NO	PART NO	QTY	DESCRIPTION
101	-----	1	SCREW, M6 X 12, Hex Head Shoulder
102	-----	1	NUT, HEX FLANGE HEAD, M6
0110	771706	1	KIT, Spring, Traction Drive -(Incl. Ref. Nos. 110, 166)
110	-----	2	SPRING, Pawl
166	-----	1	SPRING, Extension
0111	771712	1	KIT, Shaft, Pawl -(Incl. Ref. Nos. 104, 105, 111)
104	-----	2	SCREW, Hex Head, M8X20
105	-----	1	SLEEVE, PAWL
111	-----	1	SHAFT, PAWL
0117	771709	1	KIT, Planitary and Pawl Assembly -(Incl. Ref. Nos. 106, 112, 117)
106	-----	1	PAWL Assembly, Right
112	-----	1	PAWL Assembly, Left
117	-----	2	GEAR, Planitary Assembly
0125	771713	1	KIT, Shaft, Differential -(Incl. Ref. Nos. 92, 104, 114, 116, 124, 125, 126, 127, 128, 130, 131)
92	-----	1	WASHER, Lock, M8
104	-----	1	SCREW, Hex Head, M8X20
114	-----	1	WASHER, Flat, 8 X 28 X 2
116	-----	1	SPACER, SHAFT, DIFFERENTIAL
124	-----	2	WASHER, FLAT, 16X30X2
125	-----	1	SHAFT, DIFFERENTIAL
126	-----	1	KEY, FLAT, 5X5X22
127	-----	1	WASHER, FLAT, 14X28X2
128	-----	1	RING, RETAINING, 14
130	-----	1	WASHER, Flat, 10 X 28 X 2
131	-----	1	NUT, Lock, M10
0139	771711	1	KIT, Shaft, Traction Drive LH -(Incl. Ref. Nos. 98, 136, 139, 140, 141, 142)
98	-----	3	SCREW, Hex Head W/ Flat Washer, M6 X 12
136	-----	1	SLEEVE, Drive Shaft
139	-----	1	AXLE
140	-----	1	WASHER, LOCK, M15
141	-----	1	KEY, WOODRUFF
142	-----	1	BEARING, BALL, DEEP GROOVE
0143	84003161	1	KIT, Spring -(Incl. Ref. Nos. 143, 144)
143	-----	2	SPRING, Drive Shaft
144	-----	1	SLEEVE, Drive Shaft
0154	771708	1	KIT, Friction Wheel -(Incl. Ref. Nos. 95, 97, 153, 155, 156, 157, 158, 159, 160)
95	-----	1	PIN, Spring, 6 X 30
97	-----	3	SCREW, Hex Head w/ Lock Washer, M6 X 12
153	-----	1	SHAFT, Hex
155	-----	1	RING, External Retaining
156	-----	4	RIVET, 3 X 6
157	-----	1	BEARING, Ball
158	-----	2	RETAINER, Ball Bearing
159	771892	1	WHEEL, Friction
160	-----	1	HUB, Friction Wheel
0259	771710	1	KIT, Shaft, Traction Drive RH -(Incl. Ref. Nos. 98, 140, 141, 142, 148, 259)

Transaxle Drive Group

Note: Unless noted otherwise, use the standard torque specifications

Mfg. No: 1696811-02

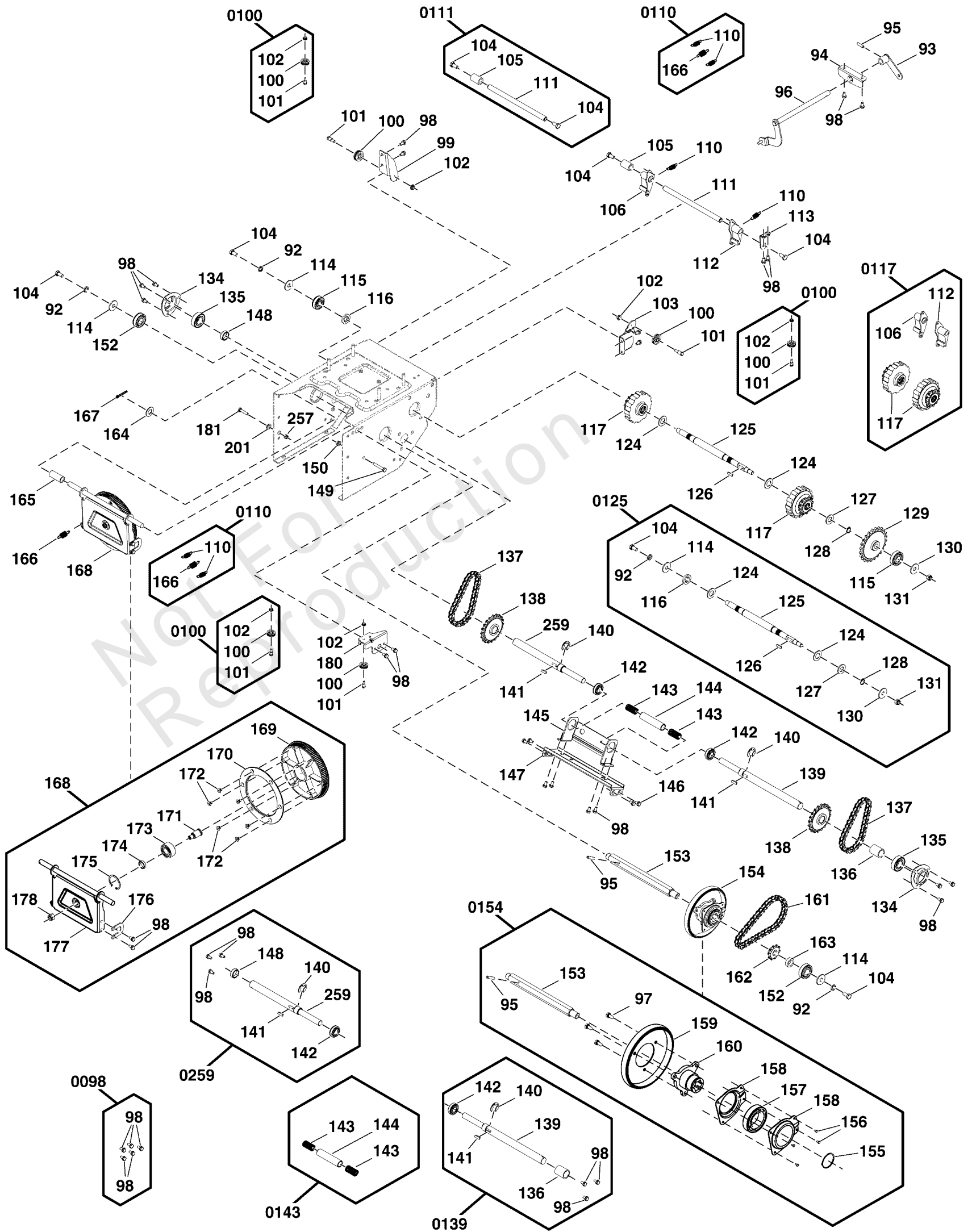

Transaxle Drive Group

REF NO	PART NO	QTY	DESCRIPTION
98	-----	3	SCREW, Hex Head W/ Flat Washer, M6 X 12
140	-----	1	WASHER, LOCK, M15
141	-----	1	KEY, WOODRUFF
142	-----	1	BEARING, BALL, DEEP GROOVE
148	-----	1	SLEEVE, DRIVE SHAFT
259	-----	1	AXLE

Not For Reproduction

Wheels & Tires Group

Note: Unless noted otherwise, use the standard torque specifications

Mfg. No: 1696811-02

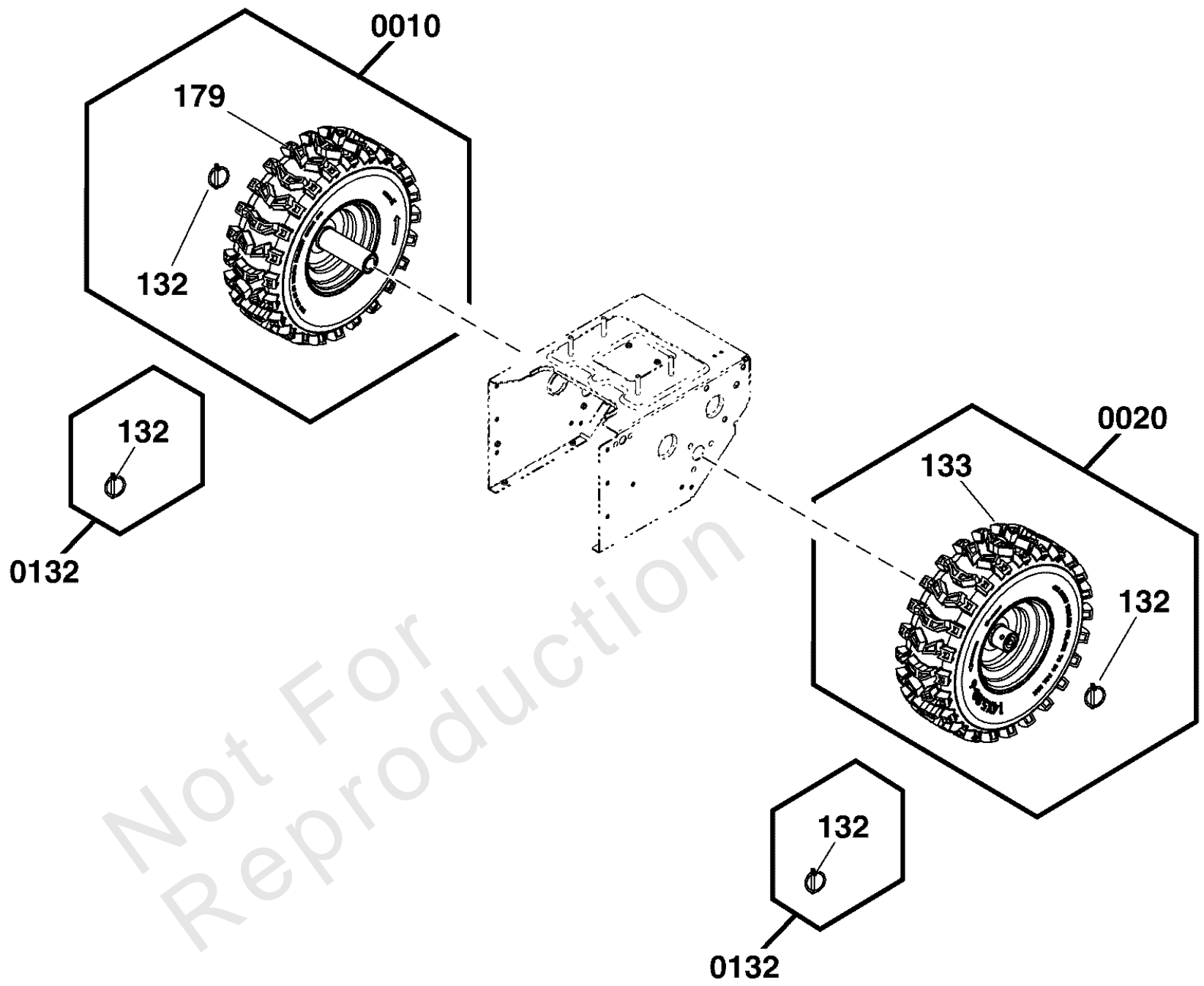

Wheels & Tires Group

REF NO	PART NO	QTY	DESCRIPTION
0010	771718	1	KIT, Wheel & Tire Right -(Incl. Ref. Nos. 132, 179)
132	-----	1	PIN, Klik
179	-----	1	WHEEL ASSEMBLY, 16 X 5, Right
0020	771719	1	KIT, Wheel & Tire Left -(Incl. Ref. Nos. 132, 133)
132	-----	1	PIN, Klik
133	-----	1	WHEEL ASSEMBLY, 16 X 5, Left
0132	84003816	2	KIT, Klik Pin -(Incl. Ref. Nos. 132)
132	-----	1	PIN, Klik

Not For Reproduction

Hardware Identification & Torque Specifications

Torque Specification Chart								
FOR STANDARD METRIC MACHINE HARDWARE (Tolerance ± 20%)								
Property Class	5.6		8.8		10.9		12.9	
	Class 5.6		Class 8.8		Class 10.9		Class 12.9	
Size Of Hardware	in/lbs	Nm.	in/lbs	Nm.	in/lbs	Nm.	in/lbs	Nm.
	ft/lbs		ft/lbs		ft/lbs		ft/lbs	
M3	5.88	.56	13.44	1.28	19.2	1.80	22.92	2.15
M4	13.44	1.28	30.72	2.90	43.44	4.10	52.56	4.95
M5	26.4	2.50	60.96	5.75	5.97	8.10	7.15	9.7
M6	44.64	4.3	7.3	9.9	10.3	14	12.1	16.5
M7	5.2	7.1	12.1	16.5	16.9	23	19.9	27
M8	7.7	10.5	17.7	24	25	34	29	40
M10	15	21	35	48	50	67	59	81
M12	26	36	61	83	86.2	117	103	140
M14	42	58	101	132	136	185	162	220
M16	64	88	147	200	210	285	250	340
M18	89	121	202	275	287	390	346	470
M20	126	171	290	390	405	550	486	660
M22	169	230	390	530	559	745	656	890
M24	217	295	497	375	708	960	840	1140
M27	320	435	733	995	1032	1400	1239	1680
M30	435	590	995	1350	1401	1900	1681	2280
M33	590	800	1349	1830	1902	2580	2278	3090
M36	759	1030	1740	2360	2441	3310	2935	3980
M39	988	1340	2249	3050	3163	4290	3798	5150

Torque Specification Chart						
FOR STANDARD MACHINE HARDWARE (Tolerance ± 20%)						
Hardware Grade	No Marks		SAE Grade 5		SAE Grade 8	
	SAE Grade 2		SAE Grade 5		SAE Grade 8	
Size Of Hardware	in/lbs	Nm.	in/lbs	Nm.	in/lbs	Nm.
	ft/lbs		ft/lbs		ft/lbs	
8-32	19	2.1	30	3.4	41	4.6
8-36	20	2.3	31	3.5	43	4.9
10-24	27	3.1	43	4.9	60	6.8
10-32	31	3.5	49	5.5	68	7.7
1/4-20	66	7.6	8	10.9	12	16.3
1/4-28	76	8.6	10	13.6	14	19.0
5/16-18	11	15.0	17	23.1	25	34.0
5/16-24	12	16.3	19	25.8	29	34.0
3/8-16	20	27.2	30	40.8	45	61.2
3/8-24	23	31.3	35	47.6	50	68.0
7/16-14	30	40.8	50	68.0	70	95.2
7/16-20	35	47.6	55	74.8	80	108.8
1/2-13	50	68.0	75	102.0	110	149.6
1/2-20	55	74.8	90	122.4	120	163.2
9/16-12	65	88.4	110	149.6	150	204.0
9/16-18	75	102.0	120	163.2	170	231.2
5/8-11	90	122.4	150	204.0	220	299.2
5/8-18	100	136	180	244.8	240	326.4
3/4-10	160	217.6	260	353.6	386	525.0
3/4-16	180	244.8	300	408.0	420	571.2
7/8-9	140	190.4	400	544.0	600	816.0
7/8-14	155	210.8	440	598.4	660	897.6
1-8	220	299.2	580	788.8	900	1,244.0
1-12	240	326.4	640	870.4	1,000	1,360.0

The guides and ruler furnished below are designed to help you select the appropriate hardware.



Nut, M8

Thread Diameter (mm)

Inside Diameter (in) Threads per inch

Nut, 1/2-16

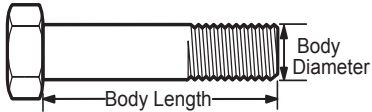

Screw, M8- 1.25 x 25

Thread Diameter (mm) Distance between threads (mm) Body Length (mm)

Body Diameter Threads per inch Body Length (in)

Screw, 1/2- 16 x 2

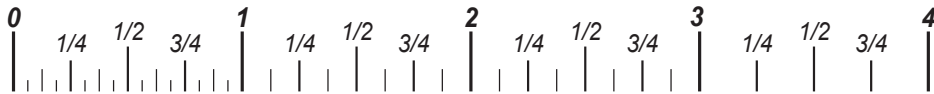

Standard Hardware Sizing

When a washer or nut is identified as 1/2" (M8), this is the *Nominal size*, meaning the *inside diameter* is 1/2 inch (8mm metric thread diameter); if a second number is present it represents the *threads per inch* (distance between threads).

When bolt or capscrew is identified as 1/2 - 16 x 2" (M8 - 1.25 x 50), this means the *Nominal size*, or body diameter is 1/2 inch (8mm metric thread diameter), the second number, 16, represents the *threads per inch*, (*distance between threads*). The final number is the body length of the bolt or screw, 2 inches (50mm).

NOTES

- These torque values are to be used for all hardware excluding: locknuts, self-tapping screws, thread forming screws, sheet metal screws and socket head setscrews.
- Recommended seating torque values for locknuts:
 - for prevailing torque locknuts - use 65% of grade 5 torques.
 - for flange whizlock nuts and screws - use 135% of grade 5 torques.
- Unless otherwise noted on assembly drawings, all torque values must meet this specification.

Common Hardware Types

Hex Head Capscrew



Washer



Carriage Bolt



Hex Nut

Wrench & Fastener Size Guide

1/4" Bolt or Nut Wrench—7/16"	5/16" Bolt or Nut Wrench—1/2"	3/8" Bolt or Nut Wrench—9/16"	7/16" Bolt or Nut Wrench (Bolt)—5/8" Wrench (Nut)—11/16"	1/2" Bolt or Nut Wrench—3/4"
M6 Bolt or Nut Wrench—10mm	M8 Bolt or Nut Wrench—13mm	M10 Bolt or Nut Wrench—17mm	M12 Bolt or Nut Wrench—19mm	M14 Bolt or Nut Wrench—22mm

