



ProPush® Hydraulic Push Box Spreaders
HP 140, 150 & 160



SIMPLE DESIGN, DEPENDABLE SERVICE

THE KUHN HP 140, 150 & 160 PROPUSH BOX SPREADERS ARE DESIGNED WITH SIMPLICITY IN MIND. THE HYDRAULIC PUSH-TYPE DESIGN MEANS NO APRON CHAINS, FEWER MOVING PARTS, FASTER UNLOADING AND DEPENDABLE SERVICE LIFE.



FAST, CONSISTENT, ACCURATE SPREADING
The HP ProPush spreaders come standard with VertiSpread® vertical beaters designed to haul and spread solid materials from dairies and feedlots, including gutter manure, yard scrapings, bedding pack and feedlot manure. An optional scale system is available for precise monitoring and application tracking.

BUILT TO LAST
These spreaders feature an all-steel welded box construction, poly laminate floor and sides, and reliable piggyback hydraulic cylinders to keep your machine on the farm for years to come.

| Models | Struck Level Capacity | Heaped Capacity |
|---------------|--|--|
| HP 140 | 236 ft ³ (6.6 m ³) | 365 ft ³ (10.3 m ³) |
| HP 150 | 360 ft ³ (10.2 m ³) | 495 ft ³ (14 m ³) |
| HP 160 | 450 ft ³ (12.7 m ³) | 600 ft ³ (17 m ³) |

Summary

HP 140-160 Features 4-5

Optional Equipment..... 6

Specifications 7



IMPROVED IMPLEMENT AND TRACTOR CLEARANCE

The redesigned pusher on the HP 150 & 160 features a bird beak design that allows for better cleanout of the load. This also allows the mounting point of the cylinders to be moved rearward, resulting in better clearance between the tractor and implement as well as the ability to add a CV PTO option.



BEATER DRIVE PTO

Power from the tractor to the unit is transferred through a center-mounted driveline that operates at 1,000 RPM. Primary PTOs for all models are available as either 1 3/8" (3.5 cm) or 1 3/4" (4.4 cm). The HP 140 is equipped with a non-CV PTO, while the HP 150 & 160 have a CV PTO option designed for operators that spread at low rates or operators who wish to continue spreading into headland turns.



ALL-STEEL, WELDED CONSTRUCTION

The all-steel, welded ProPush box construction provides a solid framework and includes a reinforced tongue that pulls directly from the full-width axle.

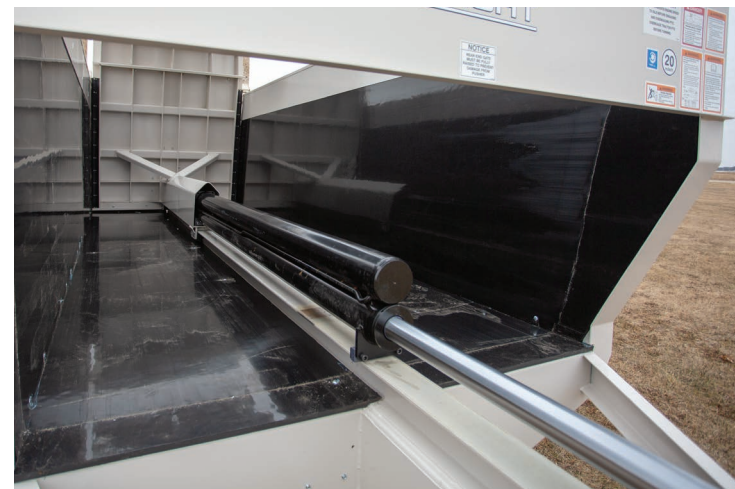

PIGGYBACK HYDRAULIC CYLINDERS

The piggyback hydraulic cylinders are totally protected by a structural tube member. This stops manure from falling directly onto the cylinder which helps prevent premature seal failure. This unique cylinder design provides smooth and uniform travel through the entire stroke and rapid cylinder retraction when spreading is completed.

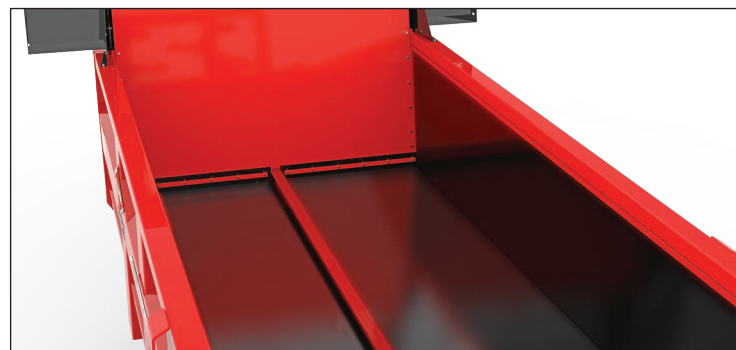

REDUCED WINTER FREEZEDOWN

A two-piece, 5/8" (1.6 cm) solid poly laminate floor and single piece, 5/8" (1.6 cm) poly laminate sides provide more strength and durability than individual tongue & groove boards while reducing friction. The reduced friction of poly laminate requires less power during unloading versus steel or wooden floors and sides. The poly laminate floor provides impact resistance when dropping heavy loads into the spreader. The plastic floor and sides also reduce winter freeze-down issues. The poly laminate floor and sides come with a 10-year breakage warranty.



VERTISPREAD® VERTICAL BEATERS

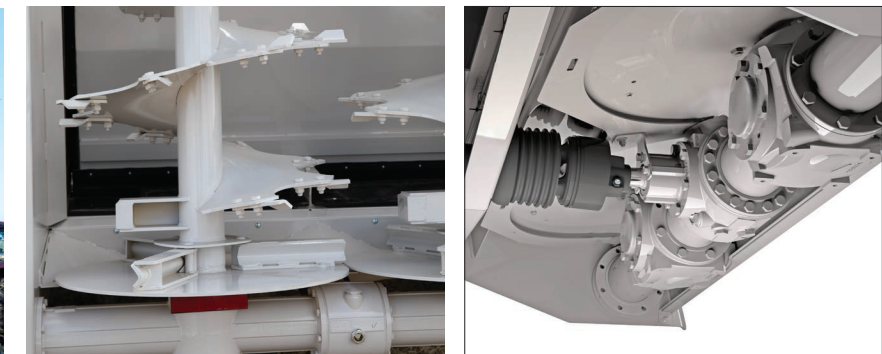

HD BEATERS & LOW-MAINTENANCE GEARBOX DESIGN

All HP spreaders come with a heavy-duty vertical beater module, featuring 5/8" (1.6 cm) fighting and hardened beater tips mounted on a Berma SRT-22 gearbox drive. However, if you're not in need of the extra reinforcement, you can select the standard vertical beater module which features 1/2" (1.3 cm) fighting and standard steel beater tips mounted on a Berma SRT-20 gearbox drive. The integral gearbox provides a heavy-duty, low maintenance design without the use of chains and sprockets. This fully enclosed, modular design allows for the beaters to be overlapped, providing an even spread pattern with excellent material breakup.

- ✓ Very efficient and consistent spread pattern
- ✓ Works great for handling most types of manure
- ✓ Simple and durable beater drive

OPTIONAL EQUIPMENT



MANUAL SPEED FLOW CONTROL

The variable speed flow control may be needed for spreading different materials and for quicker final cleanout when no variable speed hydraulic control is available on the tractor.



ELECTRIC SPEED FLOW CONTROL

An option for tractors that do not have flow control capabilities, the electric flow control allows the operator to easily adjust the pusher speed from inside the cab to suit specific materials or speeds. This provides increased flexibility when spreading a variety of materials.



SEQUENCING VALVE

An optional sequencing valve is highly recommended and can be added to the HP 140, 150 & 160 to protect against accidental pusher and gate collisions. It requires the gate to be all the way up, before it allows the pusher to be engaged.



HYDRAULIC DISC BRAKES

Hydraulic disc brakes are optional. Hydraulic disc brakes are more reliable in manure applications than drum or air brakes since they are easier to keep free of foreign material and have fewer moving parts. The hydraulic brakes are activated using the hydraulic braking port provided on the tractor.

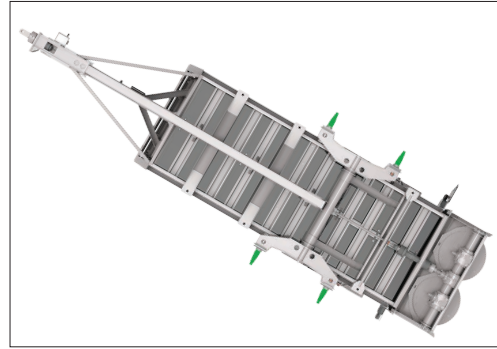

5-POINT SCALE SYSTEM AND INDICATOR

An optional 5-point scale system allows the operator to accurately determine how much material is in the spreader, as well as how much is being applied to the field. Machines equipped with electronic scales can also be fitted with an optional scale indicator, the TopCon/Digi-Star NT 560. This allows you to better manage the material they are spreading by understanding the rate at which the material is leaving the spreader. This also allows you to accurately apply the desirable tons/acre.



TIRE OPTIONS



TRUCK TIRE

Sizes available – 275/80R22.5, 385/65R22.5, 425/65R22.5

Affordable yet reliable, our recapped truck tires feature excellent load carrying capability while providing great wear characteristics, especially in applications requiring higher amounts of road travel.



IMPLEMENT TIRE

Sizes available – 16.5L x 16.1, 21.5L x 16.1

Standard implement tires provide a cost-effective flotation option for field oriented applications with less road travel.



HIGH FLOAT, LOW-PROFILE IMPLEMENT

Sizes available – 550/45-22.5, 600/55R22.5

These high-float implement tires are ideal for both field applications and road transport. They offer the most flotation for spreaders.



Technical Specifications

| | HP 140 TRAILER VERTICAL | HP 150 TRAILER VERTICAL | HP 160 TRAILER VERTICAL |
|--|---|---|-------------------------|
| Struck Level | 235 ft³ (6.6 m³) | 360 ft³ (10.2 m³) | 450 ft³ (12.7 m³) |
| Heaped | 365 ft³ (10.3 m³) | 495 ft³ (14 m³) | 600 ft³ (17 m³) |
| Maximum Net Load | 23,725 lbs (10,760 kg) | 32,175 lbs (14,595 kg) | 39,000 lbs (17,690 kg) |
| Overall Length | 358" (909 cm) | | |
| Inside Box Length | 198" (503 cm) | | |
| Inside Box Depth | 32" (81 cm) | 47" (119 cm) | 60" (152 cm) |
| Inside Box Width | 71" (180 cm) | | |
| Overall Height - Top of Beaters | 99" (251 cm) | 127" (323 cm) | |
| Overall Height - Top of Thrown Object Shield | 105" (237 cm) | 126" (320 cm) | 132" (355 cm) |
| Loading Height | 64" (163 cm) | 85" (216 cm) | 97" (246 cm) |
| Overall Tread Width | 118" (300 cm) | 130" (330 cm) | 125" (318 cm) |
| Ground Clearance | 15" (38 cm) | 21" (53 cm) | |
| Unit Weight | 9,500 lbs (4,310 kg) | 12,914 lbs (5,858 kg) | 14,160 lbs (6,425 kg) |
| Minimum PTO Power Requirement | 140 hp (104 kW) | 160 hp (119 kW) | 180 hp (134 kW) |
| Standard Number of Beaters | 2 | | |
| Number of Paddles or Teeth | 24 Teeth | 32 Teeth | |
| Beater Diameter | 37.5" (95.25 cm) | | |
| Paddle or Flighting Thickness | 0.38" or 0.50" (1 cm or 1.3 cm) | 0.38" or 0.63" (1 cm or 1.6 cm) | 0.63" (1.6 cm) |
| Overload Protection | Torque-Disconnect | | |
| Removable Beater Assembly | Standard | | |
| Beater Drive | PTO | | |
| PTO Drive Speed | 1,000 rpm | | |
| Cylinder Diameter | 3.5" (8.9 cm) | 4.5" (11.4 cm) | |
| Pusher Unload Time @ 15 gpm (seconds) | 35 | 55 | |
| Pusher and Cylinder Guides | Nylatron | | |
| Push Panel Thickness | 10 GA | | |
| Front Panel and Sides | 0.63" (1.6 cm) Poly laminate | | |
| Floor | 0.63" (1.6 cm) Poly laminate | | |
| Endgate | Fixed | | |
| Trailer Axle | Tandem | | |
| Spindle Diameter | 2.5" (6.4 cm) welded or 3" (7.6 cm) bolt-in | 3.38" (8.6 cm) welded or 3.75" (9.5 cm) bolt-in | 3.75" (9.5 cm) |
| Hubs | 8-Bolt | 10-Bolt | |
| Brakes | Optional Hydraulic Disc | | |

MyKUHNS

THE LINK TO MY SUCCESS

MyKUHNS is your online customer portal where you can access machine operator's manuals, parts catalog and more! The site is available on computer, phone or tablet, so you can access your fleet's information anywhere around the farm. Create an account and register your KUHN equipment today!



MORE PRODUCTS TO MEET YOUR NEEDS!



1. Mowers - 2. Tedders - 3. Round Balers - 4. Bale Processors - 5. TMR Mixers - 6. Primary Tillage Systems

KUHN NORTH AMERICA, INC. | Corporate Headquarters | 1501 West Seventh Avenue - Brodhead, WI 53520

For more information about your nearest KUHN dealer, visit our website www.kuhn.com

Information given in this document is only for informational purposes and is non-contractual. Our machines are in compliance with North American safety standards. In our literature, and for improved illustration of certain details, some safety devices may not be in operating position. When operating these machines, these devices must be operated in accordance with the requirements indicated in the operator's manuals and assembly manuals. We reserve the right to change any designs, specifications or materials listed without further notice. Machines and equipment in this document can be covered by at least one patent and/or registered design. Trademarks cited in this document may be registered in one or several countries.

