

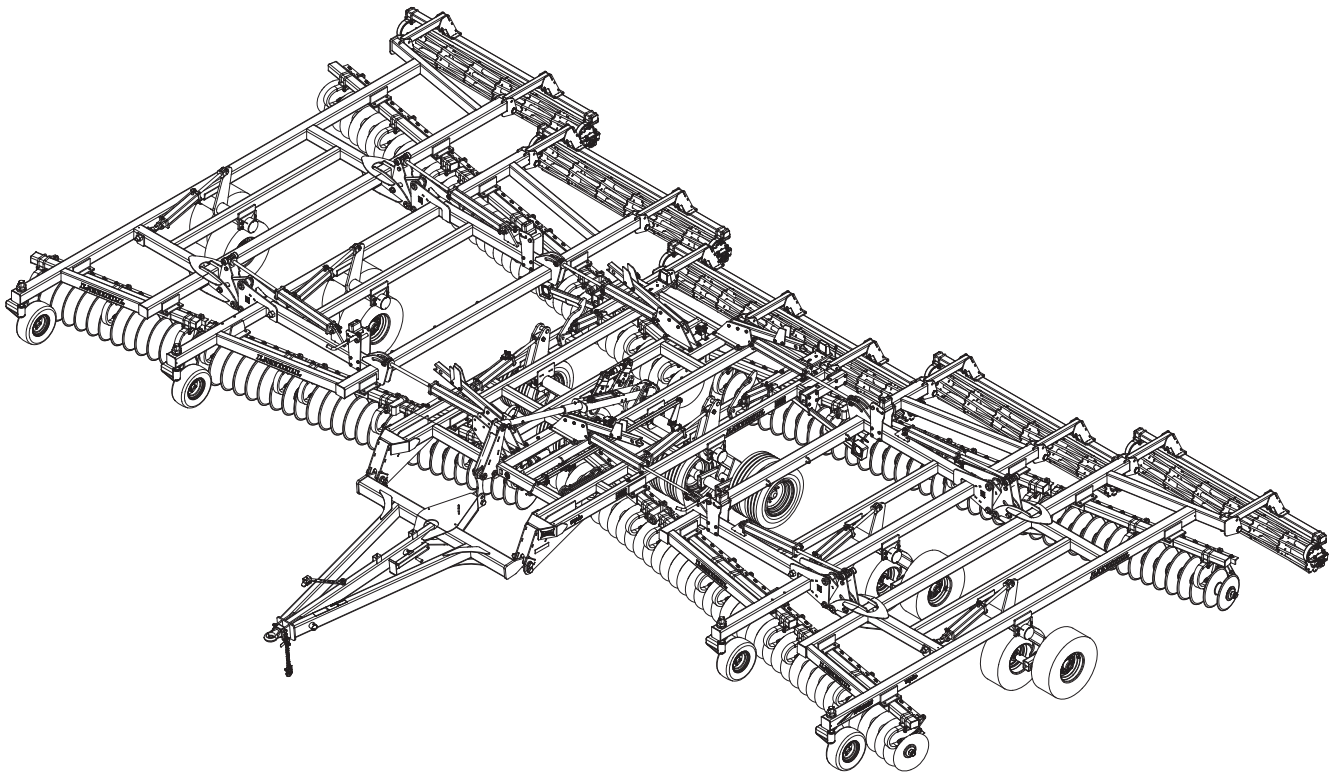

Model 7450 VT Plus Operator's Manual



LANDOLL CORPORATION

1900 North Street
Marysville, Kansas 66508
(785) 562-5381

800-428-5655 ~ WWW.LANDOLL.COM

1 Introduction and Safety Information

Introduction	1-1
Understanding Safety Statements	1-2
Decal Safety	1-2
Transporting Safety	1-2
Attaching, Detaching, and Storage	1-3
Maintenance Safety	1-3
High Pressure Fluid Safety	1-3
Protective Equipment	1-3
Chemical Safety	1-3
Prepare for Emergencies	1-3
Tire Safety	1-3
Safety Chain	1-4

2 Standard Specifications

Model Specifications	2-1
General Torque Specifications (rev. 4/97)	2-3
Hydraulic Fitting Torque Specifications	2-4

3 Assembly Instructions

Disc Gangs	3-3
Mounting Center Frame Tires and Wheels	3-3
Dual Tire Scraper Installation	3-5
Inner Wing Frames	3-5
Outer Wing Frames	3-7
7450 VT Plus Frame and Hitch Assembly	3-9
Leveler Assembly	3-11
Depth Stop Tube Installation	3-12
Hydraulic Installation	3-21
Light Installation	3-23
Rear Tow Hitch Installation	3-23
Conditioner Reel Installation	3-24
Finishing Hydraulic Conditioner Reel Installation (Option)	3-30
Final Assembly	3-36

4 Operation and Maintenance

Tractor Preparation	4-2
VT Plus Preparation	4-2
Attaching to the Tractor	4-3
Hydraulic Lift System	4-3
Hydraulic Fold System	4-5
Folding the 7450 VT Plus	4-6
Unfolding the 7450 VT Plus	4-6
General Operation	4-7
Field Operation	4-7
Leveling (Side to Side)	4-8
Leveling (Front-to-Rear)	4-10
Hitch Adjustment	4-11
Scraper Adjustment	4-12
Front Gauge Wheels	4-13
Disc Blades	4-14
Depth Stop Adjustment (Manual)	4-15
7450 – VT Wheel Bearing Maintenance	4-16
Center Frame	4-16
Wing Frame	4-17
Hydraulic Maintenance	4-18
Transport	4-18
Lubrication Maintenance	4-21
Storage	4-22

Introduction and Safety Information

Introduction

The Landoll Model 7450 VT Plus is a quality product designed to give years of trouble free performance. By following each section of this manual, your system will perform as designed for you and your operation.

- CHAPTER 1** Gives basic instructions on the use of this manual and understanding the safety statements.
- CHAPTER 2** Gives product specifications for the equipment. These specifications supply lengths and measures for your equipment. A Standard Bolt Torque Table is provided to give guidelines for bolt torques to be used when servicing this product.
- CHAPTER 3** Contains assembly instructions for your 7450 VT Plus. When these procedures are correctly followed, your equipment should provide you years of trouble-free operation and service.
- CHAPTER 4** Instructs how to operate your equipment before using it, and describes adjustments needed. Gives practical advice for the care and maintenance of your Landoll equipment. Drawings in this section locate adjustment points on the equipment.

IF YOU HAVE ANY QUESTIONS CONTACT:

**LANDOLL CORPORATION
1900 NORTH STREET
MARYSVILLE, KANSAS 66508**

PHONE # (785) 562-5381 or (800) 428-5655

OR

FAX # (888) 527-3909

- CHAPTER 5** Is a troubleshooting guide to aid in diagnosing and solving problems with the VT Plus
- PARTS MANUAL** Is a separate manual showing the various assemblies, subassemblies, and systems. Refer to that manual when ordering Landoll replacement parts. Order parts from your Landoll dealer.
- WARRANTY** The Warranty Registration form is included with the product documents. Fill it out and mail it within 15 days of purchase.
NOTE: IMPROPER ASSEMBLY, MODIFICATION, OR MAINTENANCE OF YOUR LANDOLL MACHINE CAN VOID YOUR WARRANTY.
- COMMENTS** Address comments or questions regarding this publication to:

**LANDOLL CORPORATION
1900 NORTH STREET
MARYSVILLE, KANSAS 66508
ATTENTION: PUBLICATIONS - DEPT. 55**

Understanding Safety Statements

You will find various types of safety information on the following pages and on the machine signs (decals) attached to the vehicle. This section explains their meaning.



The Safety Alert Symbol means **ATTENTION! YOUR SAFETY IS INVOLVED!**

NOTE

Means that failure to follow these instructions could cause damage to the equipment or cause it to operate improperly.

NOTICE

Special notice - read and thoroughly understand



CAUTION

Caution means serious equipment or other property damage can occur if instructions on this label are not properly followed.



WARNING

Warning means serious injury or death can occur if safety measures or instructions on this label are not properly followed.



DANGER

Danger means a life-threatening situation exists. Death can occur if safety measures or instructions on this label are not properly followed.

NOTE

Make sure you read and understand the information contained in this manual and on the machine signs (decals) before you attempt to operate or maintain this vehicle.

The safety statements contained in this manual relate to the operation of the Model 7450 VT Plus.

Decal Safety

1. Examine safety decals and be sure you have the correct safety decals for the implement.
2. Keep these signs clean so they can be observed readily. It is important to keep these decals cleaned more frequently than the implement. Wash with soap and water or a cleaning solution as required.
3. Replace decals that become damaged or lost. Also, be sure that any new implement components installed during repair include decals which are assigned to them by the manufacturer.
4. When applying decals to the implement, be sure to clean the surface to remove any dirt or residue. Where possible, sign placement should protect the sign from abrasion, damage, or obstruction from mud, dirt, oil etc.



DANGER

- Do not allow anyone to ride on the tractor or implement. Riders could be struck by foreign objects or thrown from the implement.
- Never allow children to operate equipment.
- Keep bystanders away from implement during operation.

Transporting Safety

IMPORTANT

It is the responsibility of the owner/operator to comply with all state and local laws.

1. When transporting the implement on a road or highway, use adequate warning symbols, reflectors, lights and slow moving vehicle sign as required. Slow moving tractors and towed implements can create a hazard when driven on public roads. They are difficult to see, especially at night.



2. Do not tow an implement that, when fully loaded, weighs more than 1.5 times the weight of the towing vehicle.
3. Carry reflectors or flags to mark the tractor and implement in case of breakdown on the road.

4. Do not transport at speeds over 20 MPH under good conditions. Never travel at a speed which does not allow adequate control of steering and stopping. Reduce speed if towed load is not equipped with brakes
5. Avoid sudden stops or turns because the weight of the implement may cause the operator to lose control of the tractor. Use a tractor heavier than the implement.
6. Use caution when towing behind articulated steering tractors; fast or sharp turns may cause the implement to shift sideways.
7. Keep clear of overhead power lines and other obstructions when transporting. Know the transport height and width of your implement.

Attaching, Detaching, and Storage

1. Do not stand between the tractor and implement when attaching or detaching implement unless both are not moving.
2. Block implement so it will not roll when unhitched from the tractor.
3. Store in an area where children normally do not play.

Maintenance Safety

1. Understand the procedure before doing the work. Use proper tools and equipment.
2. Make sure all moving parts have stopped.
3. Do not make adjustments or lubricate implement while it is in motion.
4. Block the implement so it will not roll when working on or under it to prevent injury.

High Pressure Fluid Safety

1. Escaping fluid under pressure can be nearly invisible and have enough force to penetrate the skin causing serious injury. Use a piece of cardboard, rather than hands, to search for suspected leaks.
2. Any fluid injected into the skin must be surgically removed within a few hours or gangrene may result.
3. Avoid the hazard by relieving pressure before disconnecting hydraulic lines.

Protective Equipment

1. Wear protective clothing and equipment.
2. Wear clothing and equipment appropriate for the job. Avoid loose fitting clothing.



3. Because prolonged exposure to loud noise can cause hearing impairment or hearing loss, wear suitable hearing protection, such as earmuffs or earplugs.

Chemical Safety

1. Agricultural chemicals can be dangerous. Improper use can seriously injure persons, animals, plants, soil and property.
2. Read chemical manufacture's instructions and store or dispose of unused chemicals as specified.
3. Handle chemicals with care and avoid inhaling smoke from any type of chemical fire.
4. Store or dispose of unused chemicals as specified by the chemical manufacturer.

Prepare for Emergencies

1. Keep a First Aid Kit and Fire Extinguisher handy.
2. Keep emergency numbers for doctor, ambulance, hospital and fire department near the phone.

Tire Safety

1. Tire changing can be dangerous and should be performed by trained personnel using correct tools and equipment.
2. When inflating tires, use a clip-on chuck and extension hose long enough to allow you to stand to one side, not in front of or over the tire assembly. Use a safety cage if available.
3. When removing and installing wheels use wheel-handling equipment adequate for the weight involved.

Safety Chain

1. Use a chain with a strength rating equal to or greater than the gross weight of towed machinery, which is 10,100 pounds minimum in accordance with ASAE S338.2 specifications. If two or more implements are pulled in tandem, a larger chain may be required. Chain capacity must be greater than the TOTAL weight of all towed implements.
2. A second chain should be used between each implement.
3. Attach the chain to the tractor drawbar support or specified anchor location. Allow only enough slack in the chain to permit turning. The distance from hitch pin to attachment point or intermediate support point should not exceed 9 inches.

Replace the chain if any links or end fittings are broken, stretched or damaged.

Standard Specifications

Model Specifications

7450 VT Plus			
Model Number	7450-39	7450-44	7450-49
Working Width	39'-9"	44'-9"	49'-9"
Transport Width	17'-4"	17'-4"	17'-4"
Transport Height	11'-0"	12'-3"	13'-6"
Blade Diameter	22"	22"	22"
Number of Blades	66/68	74/76	82/84
Number of Bearings	18/18	20/20	20/20
Tire Size, Ply and Wheels	235/75R17.5 Tires W/8 Bolt Walking Dual Wheels (Center Frame) 320/70R15 (Wings)	235/75R17.5 Tires W/8 Bolt Walking Dual Wheels (Center Frame) VF 410/50 R16.5 (Wings)	235/75R17.5 Tires W/8 Bolt Walking Dual Wheels (Center Frame) VF 410/50 R16.5 (Wings)
Spindle Size	4" (Center) 3" (Wings)	4" (Center) 3" (Wings)	4" (Center) 3" (Wings)
Wheel Bolt Pattern	8 Bolt	8 Bolt	8 Bolt
Estimated Weight (W/6 Ga. Blade Option)	37,170 lbs.	39,490 lbs.	41,810 lbs.
NOTE: Specifications Are Subject To Change Without Prior Notification			

Tire Inflation			
Tire Size	Tire Manufacturer	Ply/Load Rating	Inflation Pressure (Psi) (Max.)
235/75R17.5	Double Coin	16 Ply (Load Range H)/6,005 lbs.	125 psi
320/70R15	Firestone	Load Index 144/6,150 lbs @ 40 mph.	70 psi
32/1550 X R16.5	Galaxy	G Load/8,000 lbs. @ 20 mph	115psi.
20.5 X 8.0-10		Load Range D/1,320 lbs.	70 psi
VF 410/50 R16.5	BKT	153A8/B - 8,050 lbs. @ 30 mph	73 psi

Specific Bolt Torques	
Bolts & Nuts	Torque (FT. LBS.)
Center Frame Nuts (Inner)	Torque to 100 Ft./Lbs. while rotating. Back to loose and tighten by hand until contact is made with bearing.
Center Frame Nuts (Outer)	300 Ft./Lbs. .
Center Frame Wheel Nuts	450-500 Ft./Lbs.
Wing Frame Wheel Nuts	85-100 Ft./Lbs.
Disc Gang Shafts	1,200 Ft./Lbs.
5/8-18 (Heavy Duty Disc)	85-100 Ft./Lbs.

General Torque Specifications (rev. 4/97)

TORQUE SPECIFIED IN FOOT POUNDS - This chart provides tightening torques for general purpose applications when special torques are not specified on process or drawing. Assembly torques apply to plated nuts and capscrews assembled without supplemental lubrication (as received condition). They do not apply if special graphite moly-disulfide or other extreme pressure lubricants are used. When fasteners are dry (solvent cleaned) add 33% to as received condition torque. Bolt head identification marks indicate grade and may vary from manufacturer to manufacturer. Thick nuts must be used on grade 8 capscrews. Use value in [] if using prevailing torque nuts.

UNC SIZE	SAE Grade 2	SAE Grade 5	SAE Grade 8	UNF SIZE	SAE Grade 2	SAE Grade 5	SAE Grade 8
1/4-20	4 [5]	6 [7]	9 [11]	1/4-28	5 [6]	7 [9]	10 [12]
5/16-18	8 [10]	13 [13]	18 [22]	5/16-24	9 [11]	14 [17]	20 [25]
3/8-16	15 [19]	23 [29]	35 [42]	3/8-24	17 [21]	25 [31]	35 [44]
7/16-14	24 [30]	35 [43]	55 [62]	7/16-20	27 [34]	40 [50]	60 [75]
1/2-13	35 [43]	55 [62]	80 [100]	1/2-20	40 [50]	65 [81]	90 [112]
9/16-12	55 [62]	80 [100]	110 [137]	9/16-18	60 [75]	90 [112]	130 [162]
5/8-11	75 [94]	110 [137]	170 [212]	5/8-18	85 [106]	130 [162]	180 [225]
3/4-10	130 [162]	200 [250]	280 [350]	3/4-16	150 [188]	220 [275]	320 [400]
7/8-9	125 [156]	320 [400]	460 [575]	7/8-14	140 [175]	360 [450]	500 [625]
1-8	190 [237]	408 [506]	680 [850]	1-14	210 [263]	540 [675]	760 [950]
1-1/8-7	270 [337]	600 [750]	960 [1200]	1-1/8-12	300 [375]	660 [825]	1080 [1350]
1-1/4-7	380 [475]	840 [1050]	1426 [1782]	1-1/4-12	420 [525]	920 [1150]	1500 [1875]
1-3/8-6	490 [612]	1010 [1375]	1780 [2225]	1-3/8-12	560 [700]	1260 [1575]	2010 [2512]
1-1/2-6	650 [812]	1460 [1825]	2360 [2950]	1-1/2-12	730 [912]	1640 [2050]	2660 [3325]
1-3/4-5	736 [920]	1651 [2063]	2678 [3347]	1-3/4-12	920 [1150]	2063 [2579]	3347 [4183]

METRIC:

Coarse thread metric class 10.9 fasteners and class 10.0 nuts and through hardened flat washers, phosphate coated, Rockwell "C" 38-45. Use value in [] if using prevailing torque nuts.

Nominal thread diameter (mm)	Newton Meters (Standard Torque)	Foot Pounds (Standard Torque)	Nominal Thread Diameter (mm)	Newton Meters (Standard Torque)	Foot Pounds (Standard Torque)
6	10 [14]	7 [10]	20	385 [450]	290 [335]
7	16 [22]	12 [16]	24	670 [775]	500 [625]
8	23 [32]	17 [24]	27	980 [1105]	730 [825]
10	46 [60]	34 [47]	30	1330 [1470]	990 [1090]
12	80 [125]	60 [75]	33	1790 [1950]	1340 [1450]
14	125 [155]	90 [115]	36	2325 [2515]	1730 [1870]
16	200 [240]	150 [180]	39	3010 [3210]	2240 [2380]
18	275 [330]	205 [245]			

Table 2-1: General Torque Specifications

Hydraulic Fitting Torque Specifications

TORQUE IS SPECIFIED IN FOOT POUNDS- 37° JIC, ORS, & ORB (REV. 10/97)
 This chart provides tightening torques for general purpose applications when special torques are not specified on process or drawing. Assembly torques apply to plated nuts and capscrews assembled without supplemental lubrication (as received condition). They do not apply if special graphite moly-disulfide or other extreme pressure lubricants are used. When fasteners are dry (solvent cleaned) add 33% to as received condition torque. Bolt head identification marks indicate grade and may vary from manufacturer to manufacturer. Thick nuts must be used on grade 8 capscrews. Use value in [] if using prevailing torque nuts.

Parker Brand Fittings			
Dash Size	37 Degree JIC	O-Ring (ORS)	O-Ring Boss (ORB)
-4	11-13	15-17	13-15
-5	14-16	-----	21-23
-6	20-22	34-36	25-29
-8	43-47	58-62	40-44
-10	55-65	100-110	58-62
-12	80-90	134-146	75-85
-16	115-125	202-218	109-121
-20	160-180	248-272	213-237
-24	185-215	303-327	238-262
-32	250-290	-----	310-340
Gates Brand Fittings			
Dash Size	37 Degree JIC	O-Ring (ORS)	O-Ring Boss (ORB)
-4	10-11	10-12	14-16
-5	13-15	-----	-----
-6	17-19	18-20	24-26
-8	34-38	32-40	37-44
-10	50-56	46-56	50-60
-12	70-78	65-80	75-83
-14	-----	65-80	-----
-16	94-104	92-105	111-125
-20	124-138	125-140	133-152
-24	156-173	150-180	156-184
-32	219-243	-----	-----
Aeroquip Brand Fittings			
Dash Size	37 Degree JIC	O-Ring (ORS)	O-Ring Boss (ORB)
-4	11-12	10-12	14-16
-5	15-16	-----	16-20
-6	18-20	18-20	24-26
-8	38-42	32-35	50-60
-10	57-62	46-50	75-80
-12	79-87	65-70	125-135
-14	-----	-----	160-180
-16	108-113	92-100	200-220
-20	127-133	125-140	210-280
-24	158-167	150-165	270-360
-32	245-258	-----	-----

Table 2-2: Hydraulic Fitting Torque Specifications

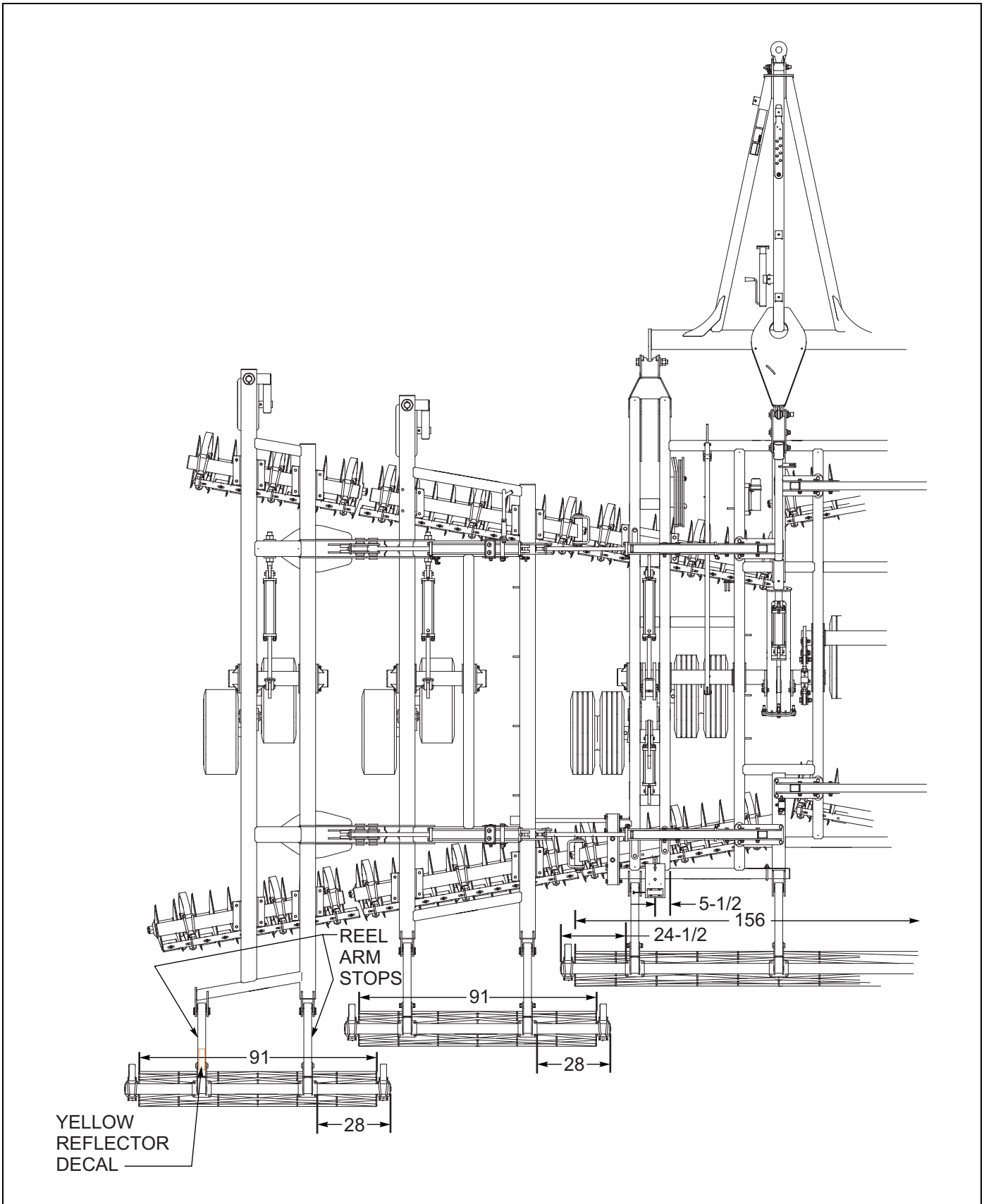

Figure 2-1: Wing Stabilizer and Light Bracket Placement (39' Model)
(Left Half)

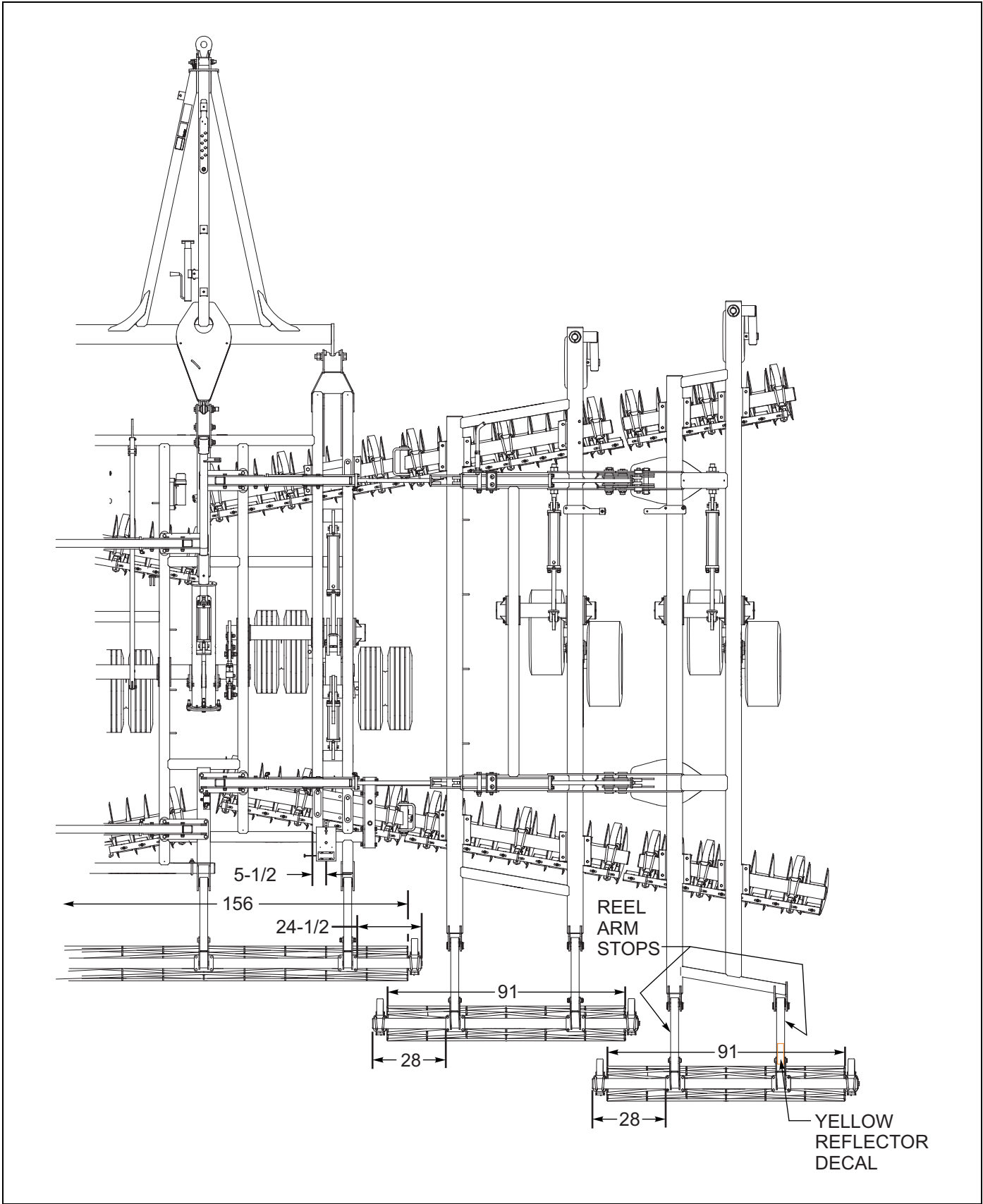

Figure 2-2: Wing Stabilizer and Light Bracket Placement (39' Model)
(Right Half)

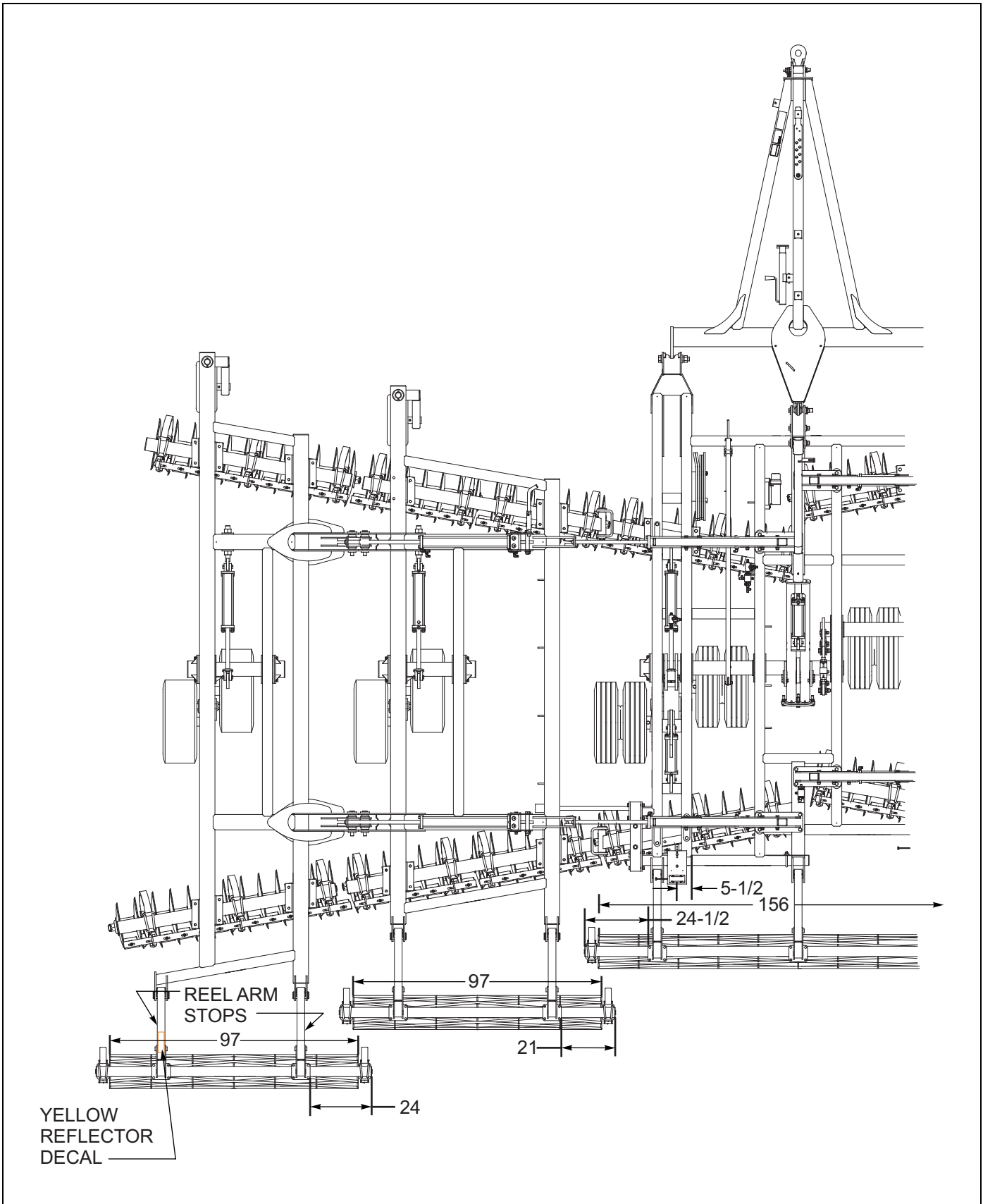

Figure 2-3: Wing Stabilizer and Light Bracket Placement (44' Model)
(Left Half)

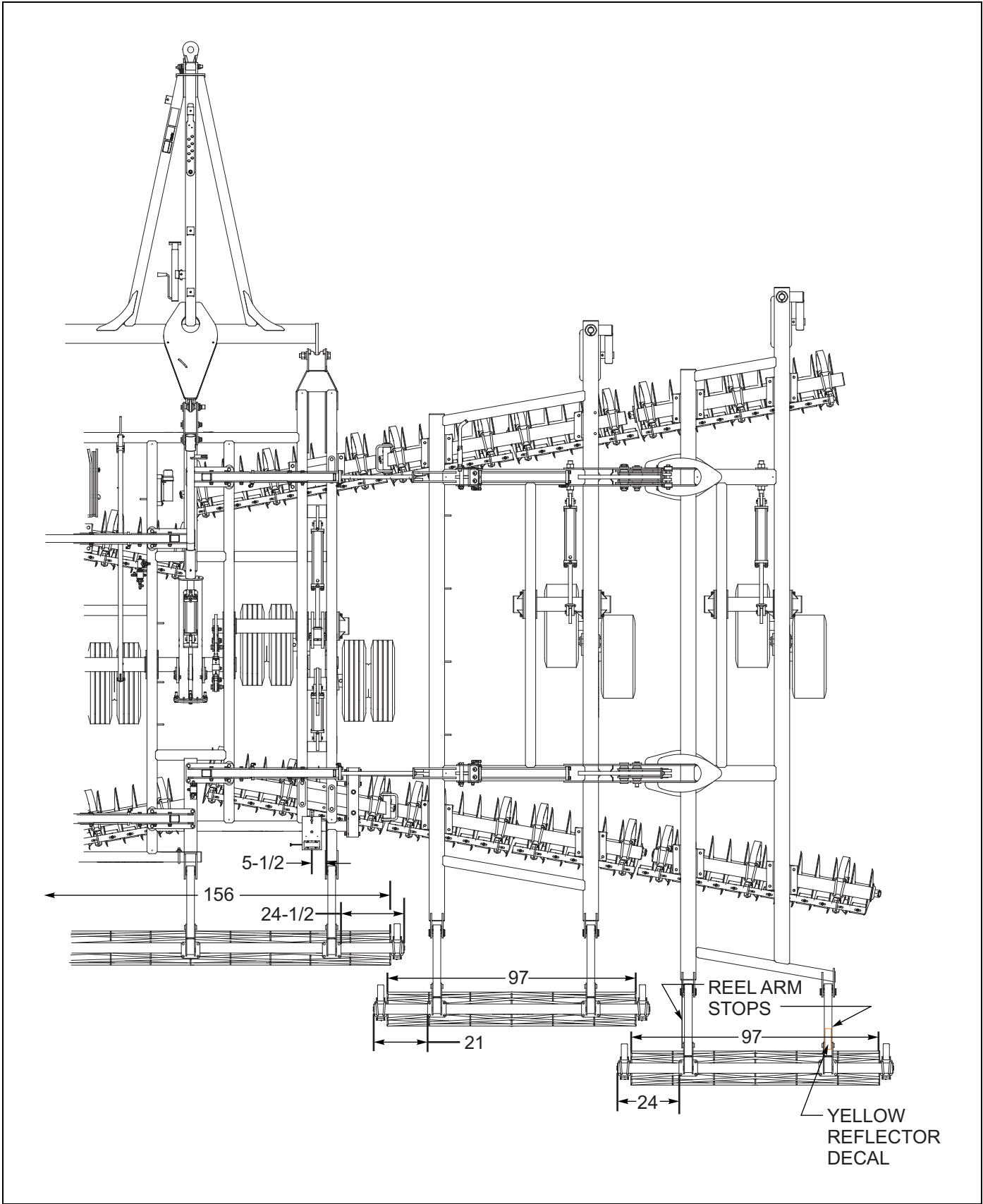

Figure 2-4: Wing Stabilizer and Light Bracket Placement (44' Model)
(Right Half)

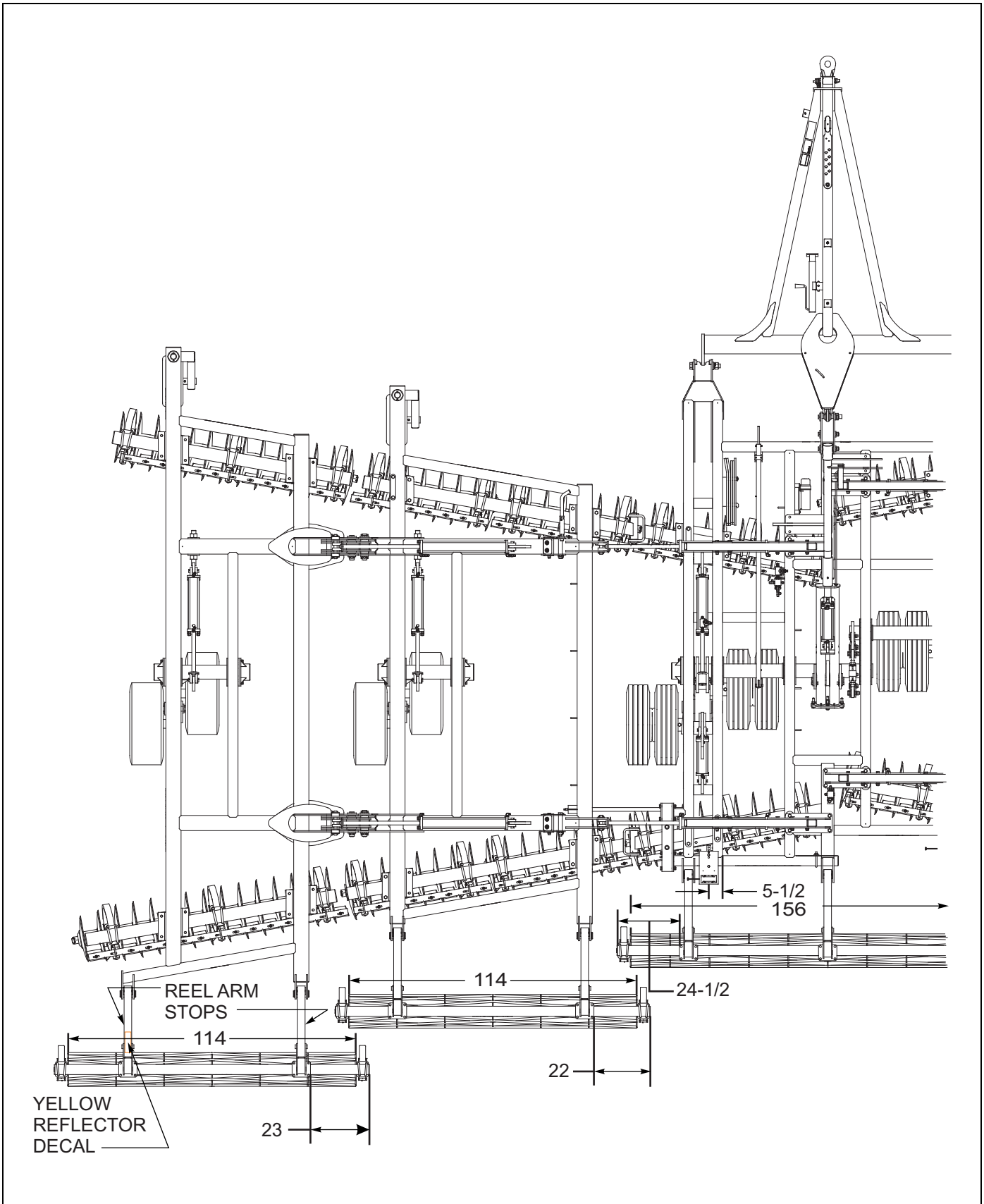

Figure 2-5: Wing Stabilizer and Light Bracket Placement (49' Model)
(Left Half)

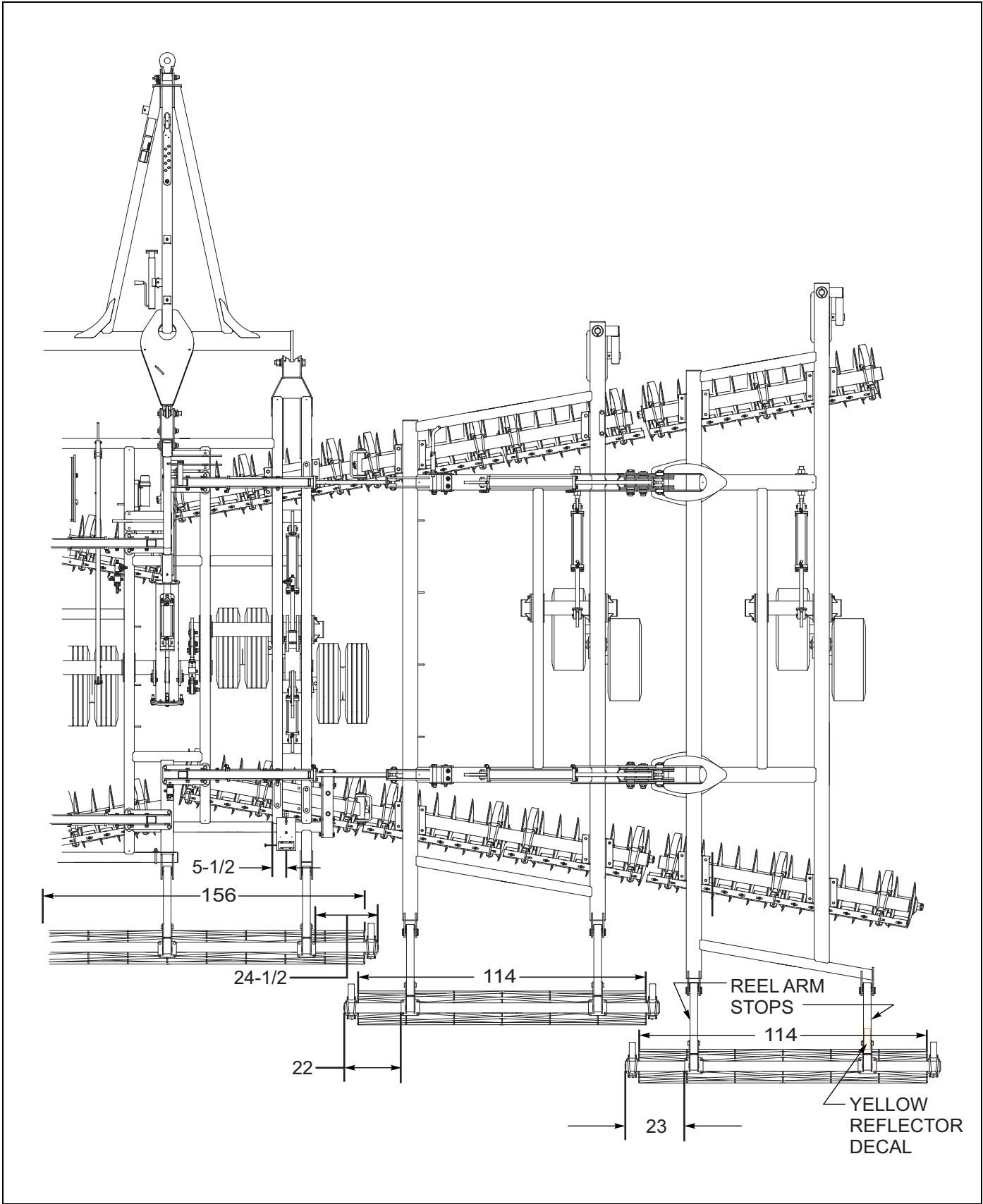

Figure 2-6: Wing Stabilizer and Light Bracket Placement (49' Model)
(Right Half)

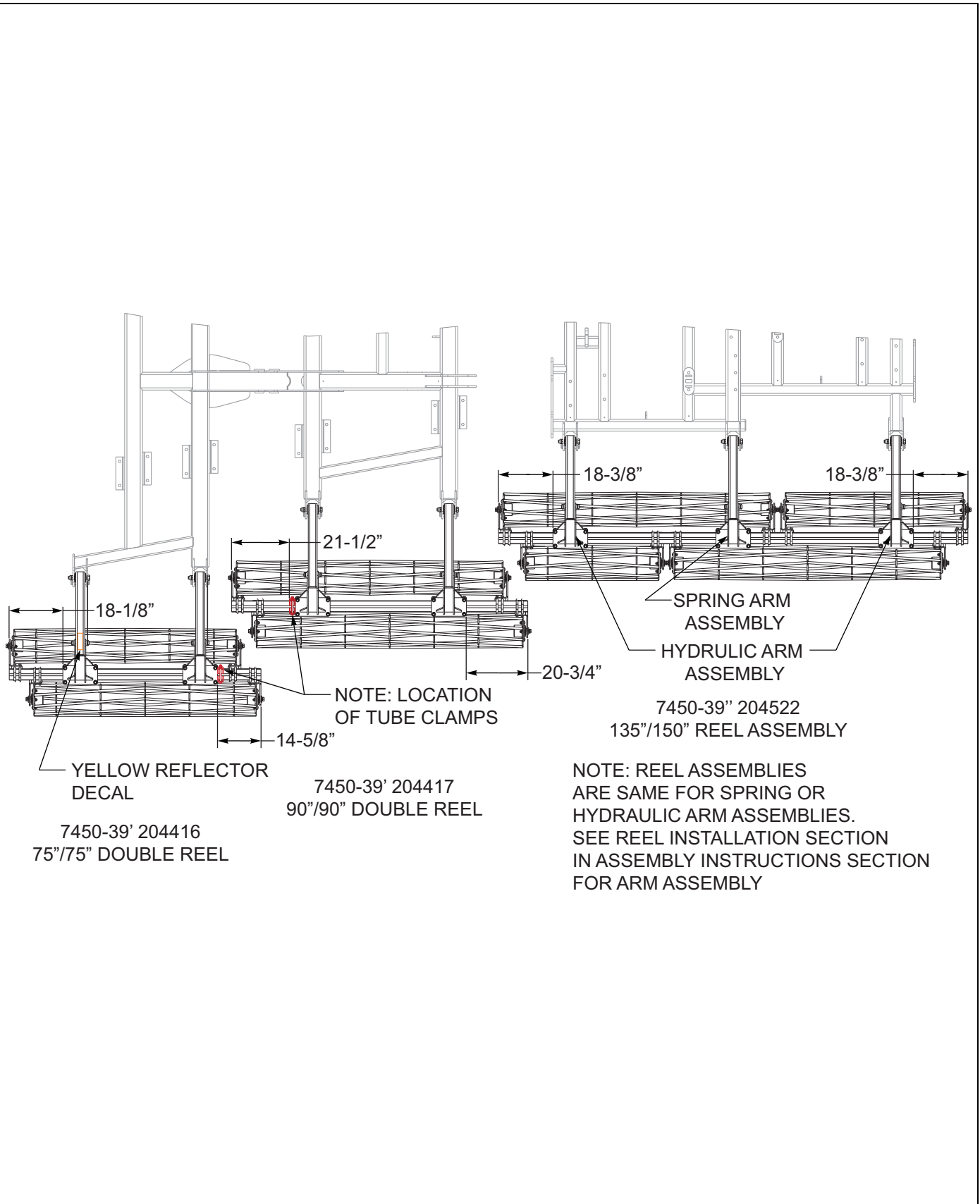

Figure 2-7: Double Round Reel Placement LH 7540-39')

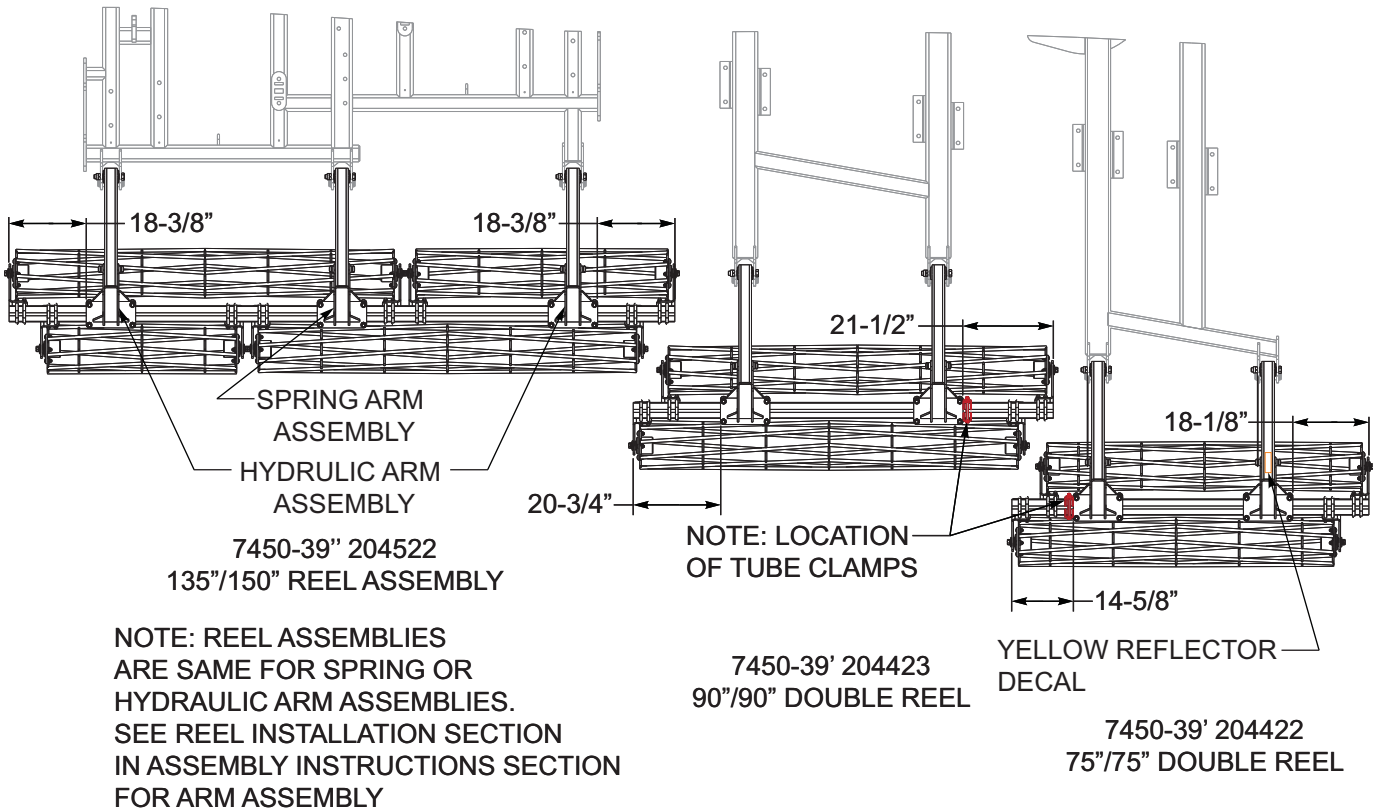

Figure 2-8: Double Round Reel Placement RH 7540-39')

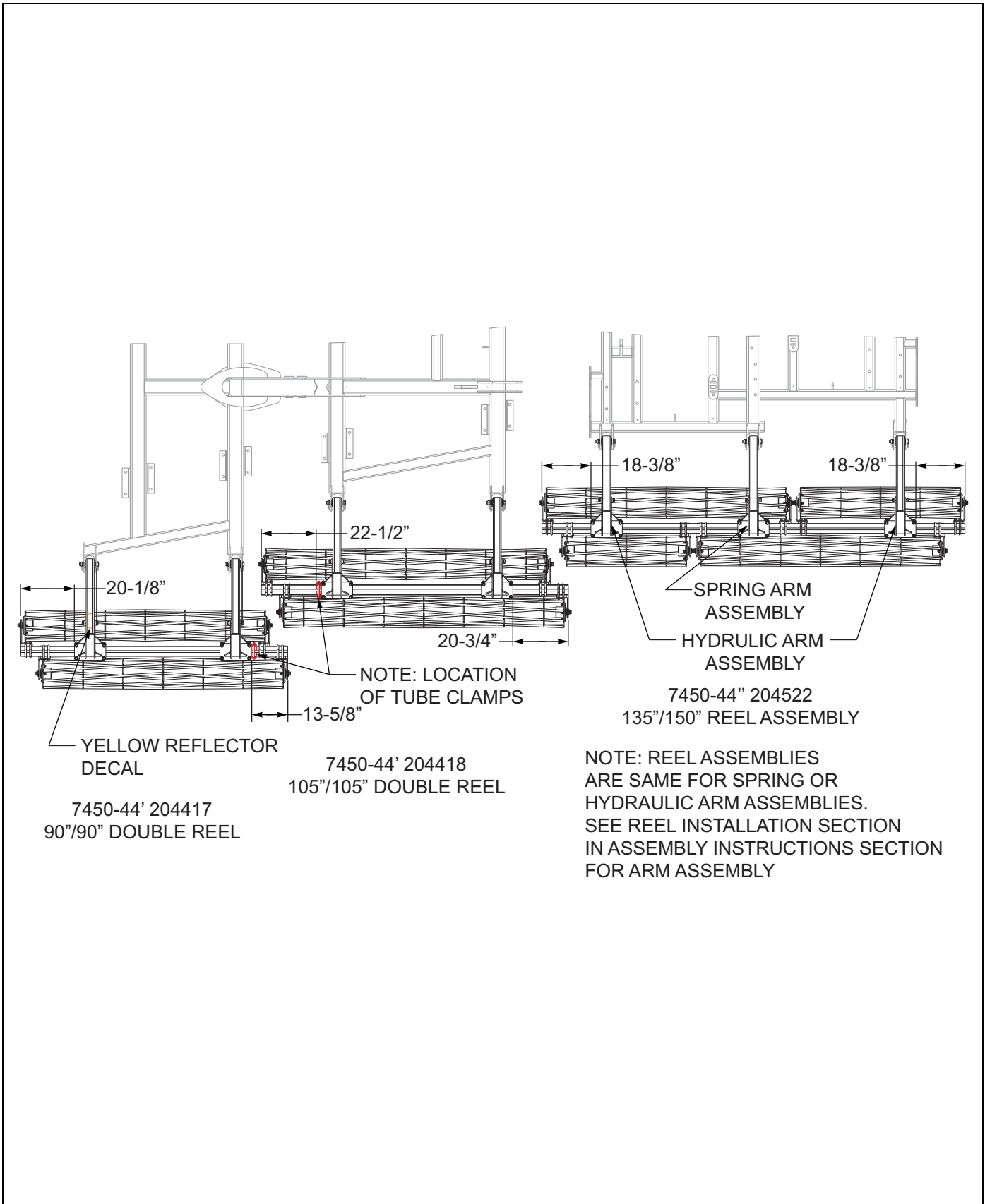

Figure 2-9: Double Round Reel Placement LH 7540-44')

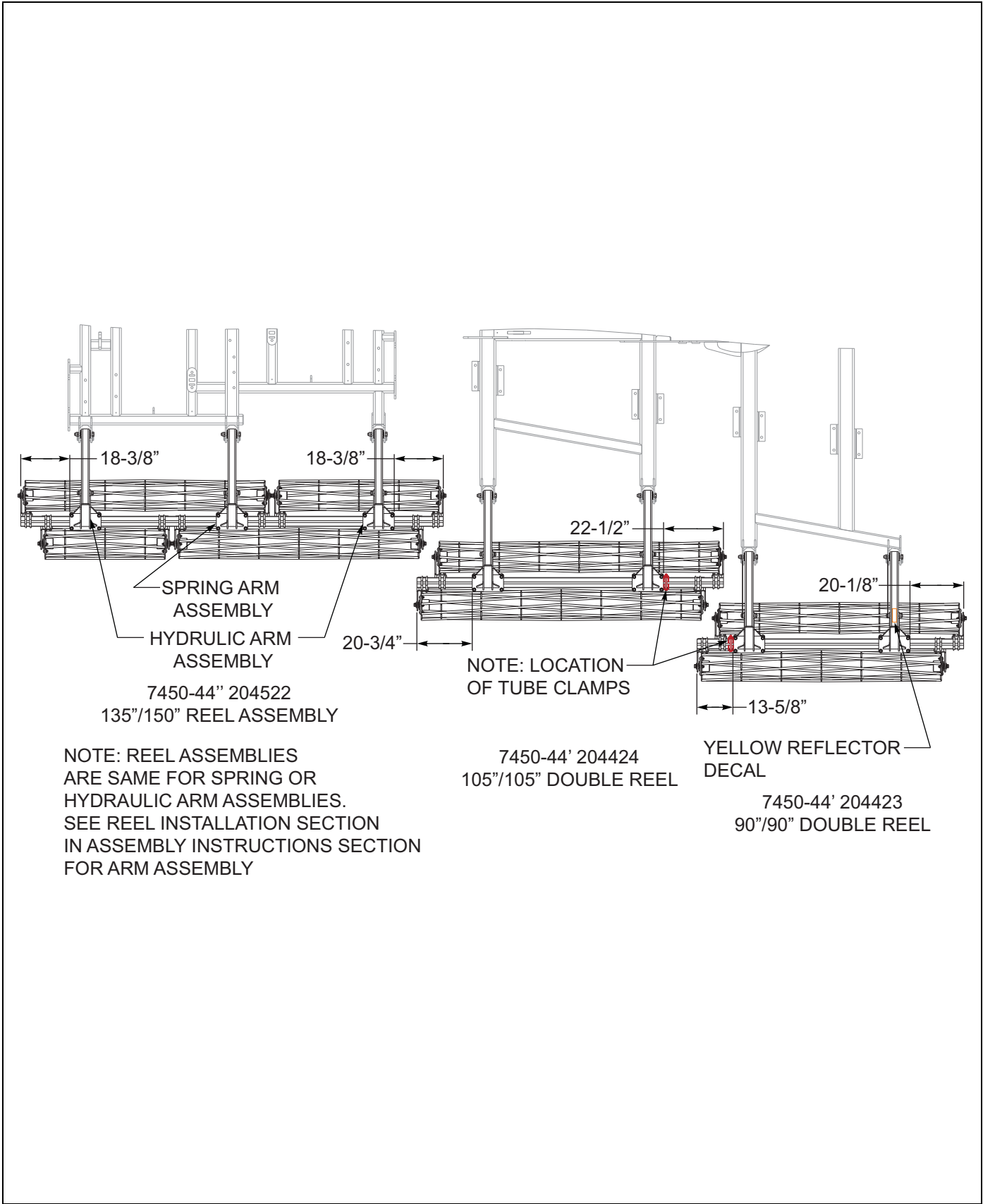

Figure 2-10: Double Round Reel Placement RH 7540-44')

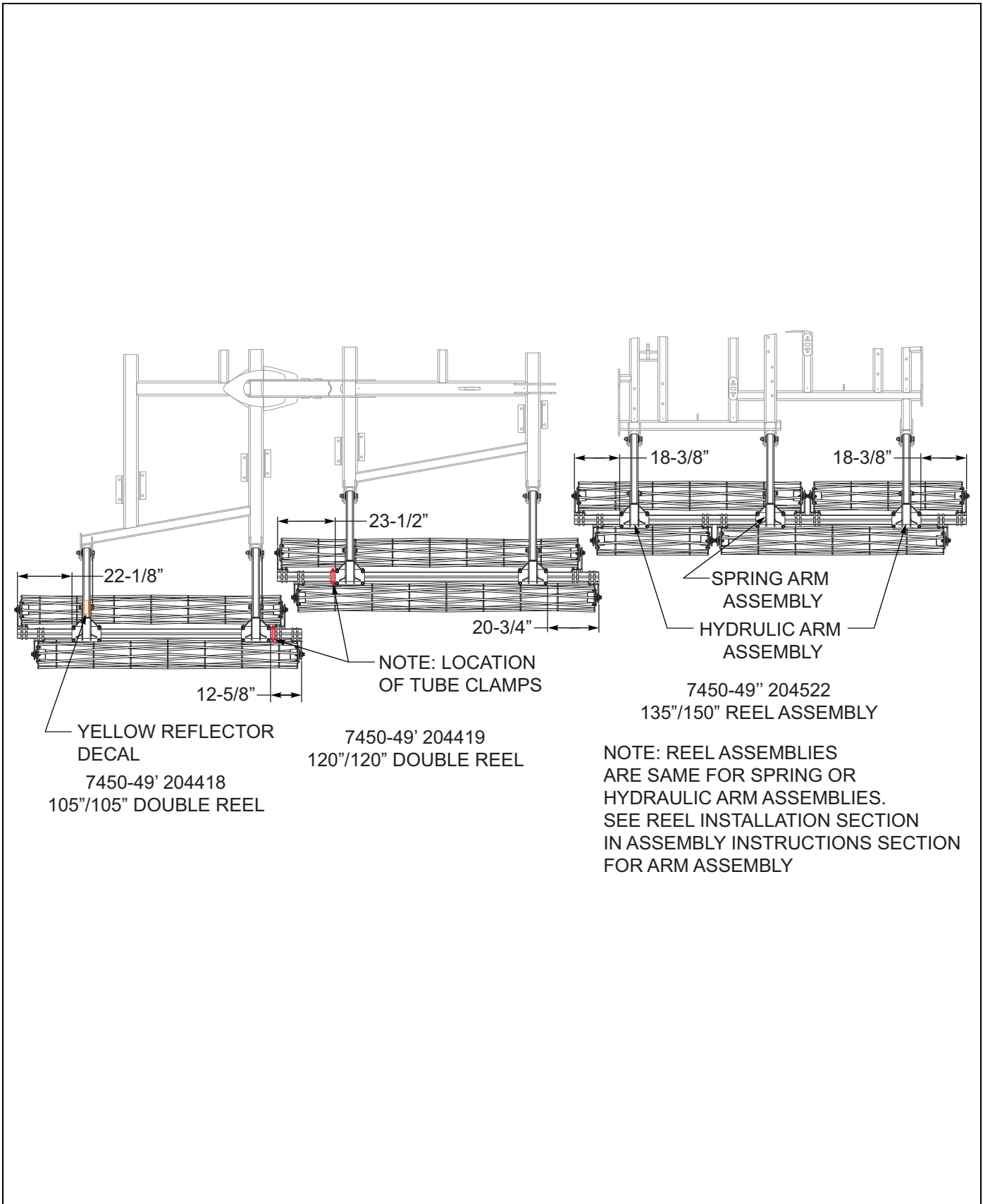

Figure 2-11: Double Round Reel Placement LH 7540-49')

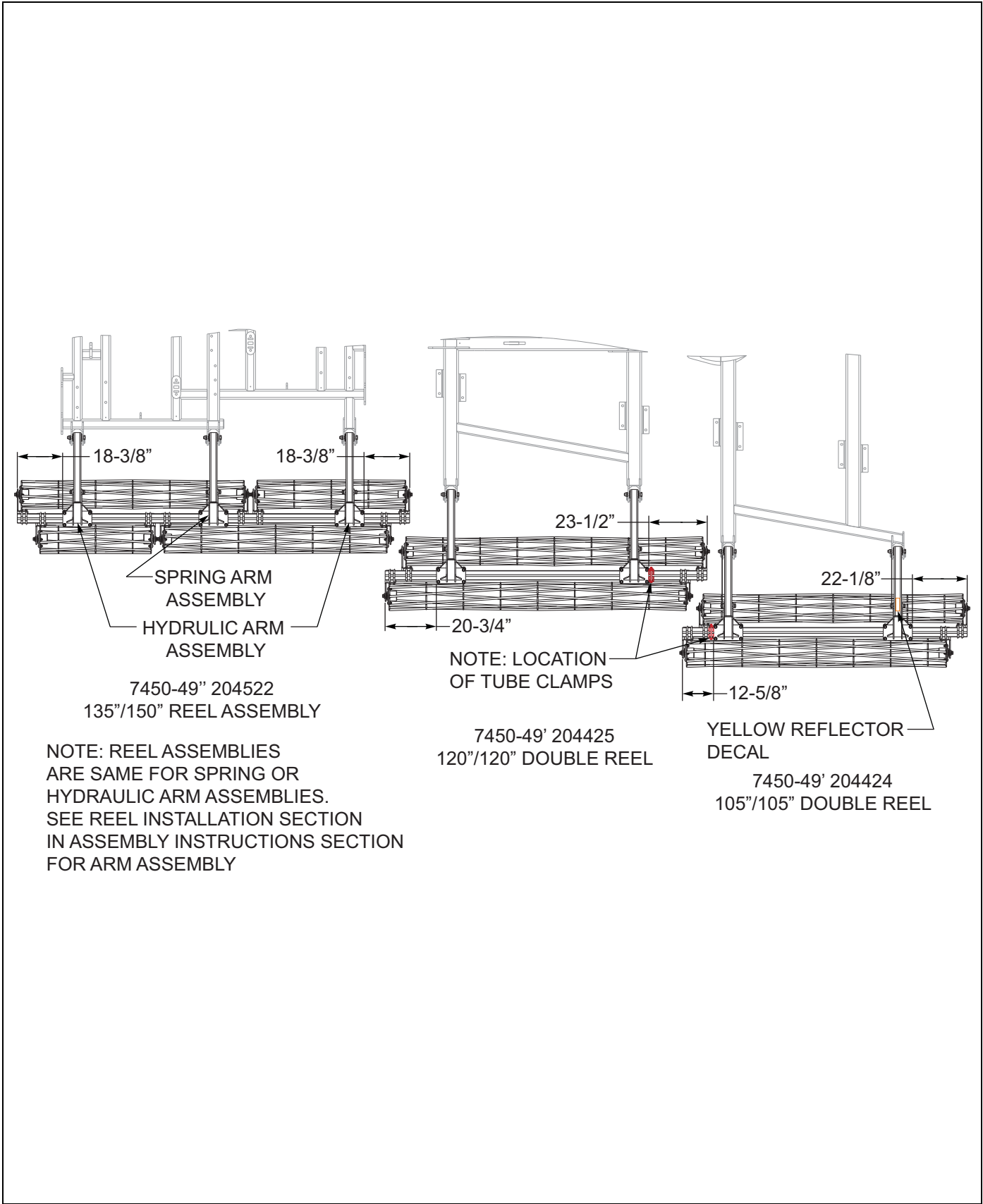

Figure 2-12: Double Round Reel Placement RH 7540-49')

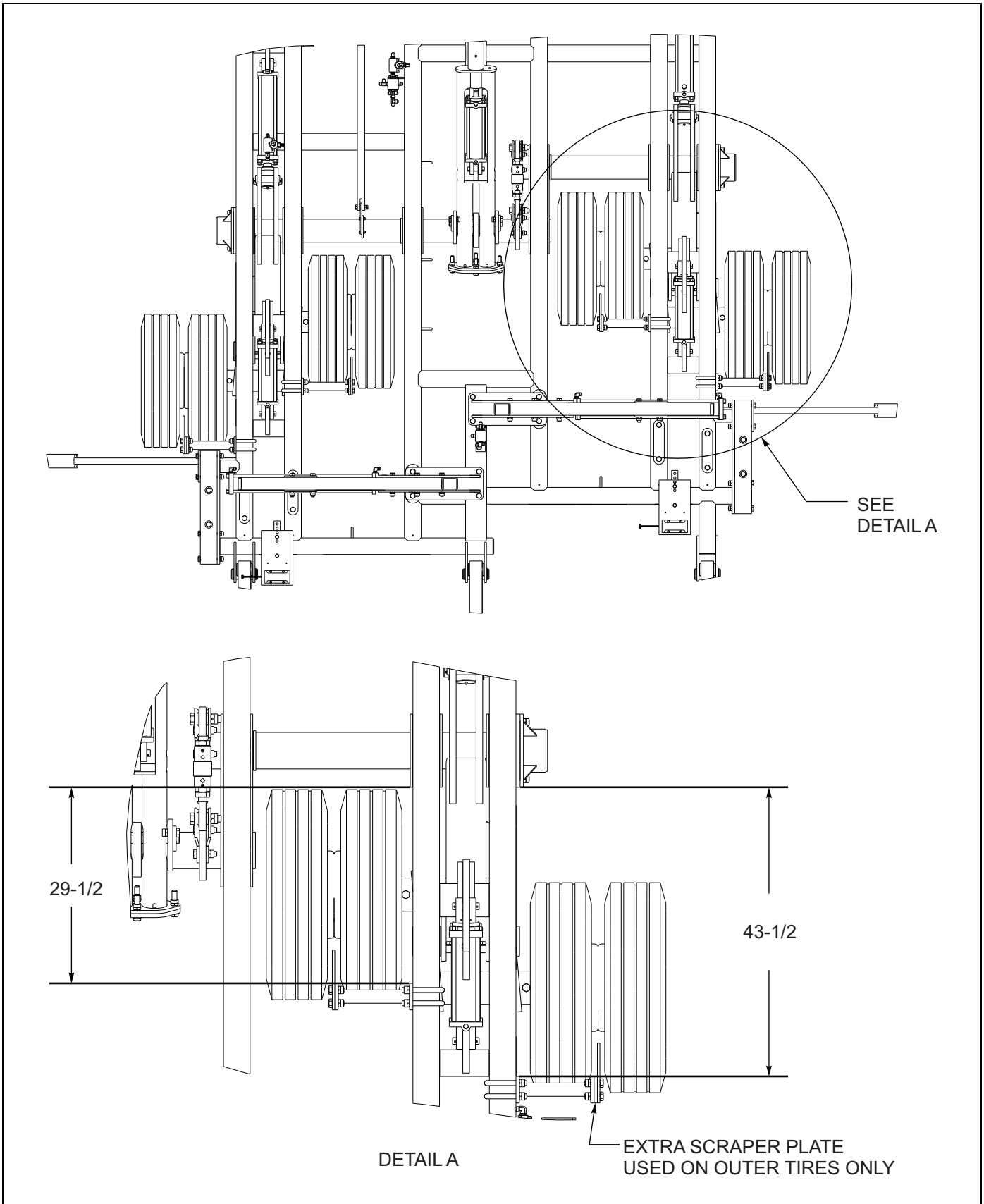

Figure 2-13: Dual Tire Scraper Installation

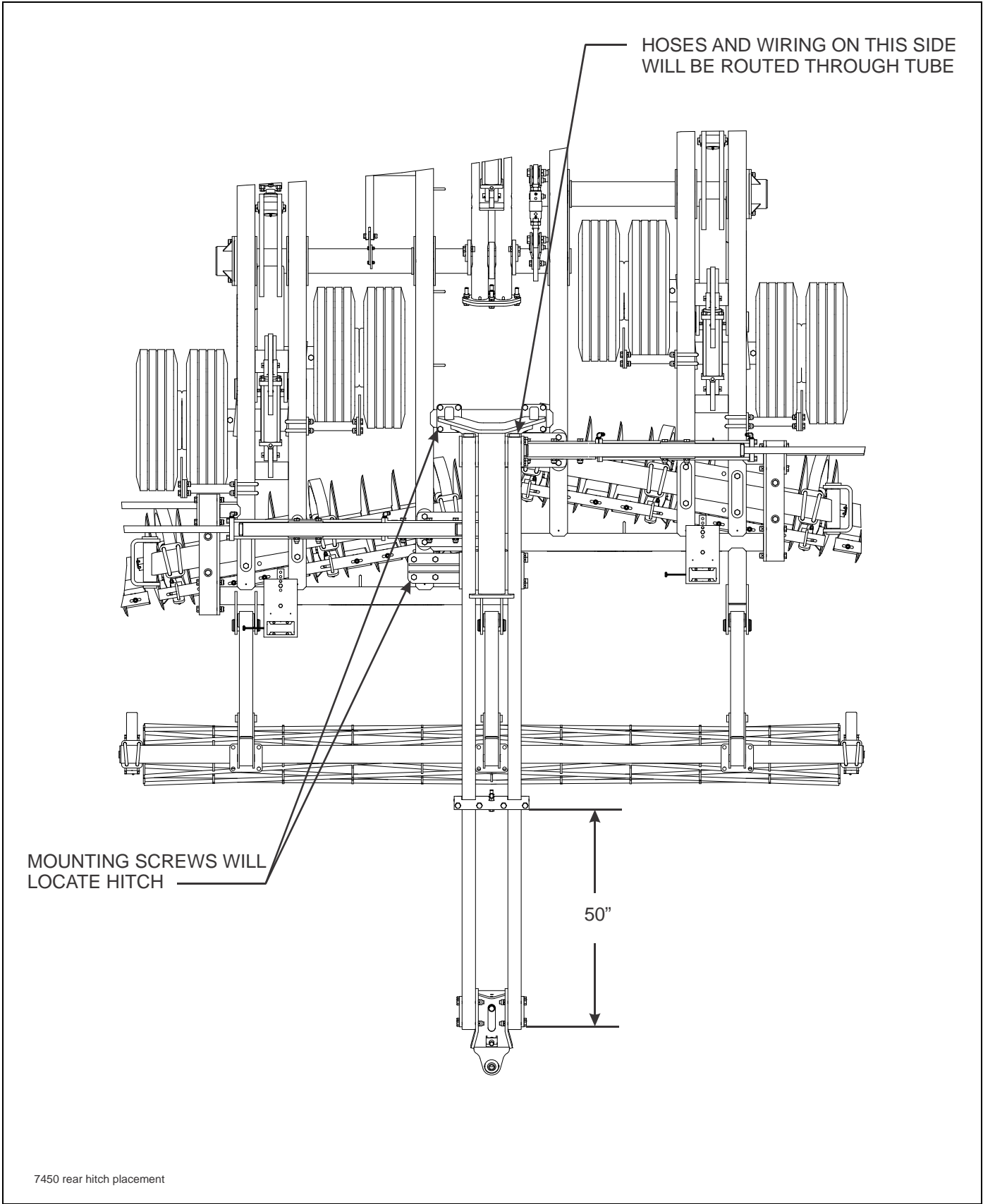

Figure 2-14: Rear Tow Hitch Installation

Assembly Instructions

It is very important that your new 7450 VT Plus be properly assembled, adjusted and lubricated before use. Illustrations to assist with the assembly process are provided in “**Standard Specifications**” on page 2-1.

They show proper disc gang, wing stabilizer bracket, and light mounting bracket spacing. Illustrations in this section show proper assembly procedures. Remove paint from grease fittings. Replace any grease fittings that are damaged or missing. Be sure to return screws, clips, etc., to their original locations.

To insure alignment of assemblies, **leave the nuts loose until completion** of final assembly. Use lock washers or flat washers as specified. Spread all cotter pins.

After completion of final assembly, tighten all nuts evenly to prevent misalignment, distortion or binding. Tighten all screws and nuts to the recommended torques (See “**General Torque Specifications (rev. 4/97)**” on page 2-3.).



CAUTION

Be sure to bleed the hydraulic system of all air in lines after installation. Failure to bleed the system of all air can result in improper machine operation.



DANGER

Disc blades are extremely sharp. Exercise extreme care when working on or near disc blades. Do not allow discs to roll over or fall onto any bodily part. Do not allow wrenches to slip when working near disc blades. Never push wrenches toward disc blades. Do not climb over machine above disc blades. Failure to stay clear of disc blade edges can cause serious personal injury or death.



WARNING

Do not attempt to lift heavy parts (such as the frame, disc gangs, rock shaft, and pull hitch) manually. Use a hoist or a fork lift to move these parts into position.



DANGER

To prevent accidental lowering:

1. All hydraulically elevated equipment must be locked out using the cylinder lockouts:
2. Lower equipment to the ground while servicing or when it is idle.

Failure to take measures to prevent accidental lowering may result in serious personal injury or death.

NOTE: INSTALL RH/LH LIGHT BRACKETS AFTER INNER WING DISC GANGS ARE INSTALLED OR THE LIGHT BRACKETS WILL INTERFERE WITH THE HINGE PINS.

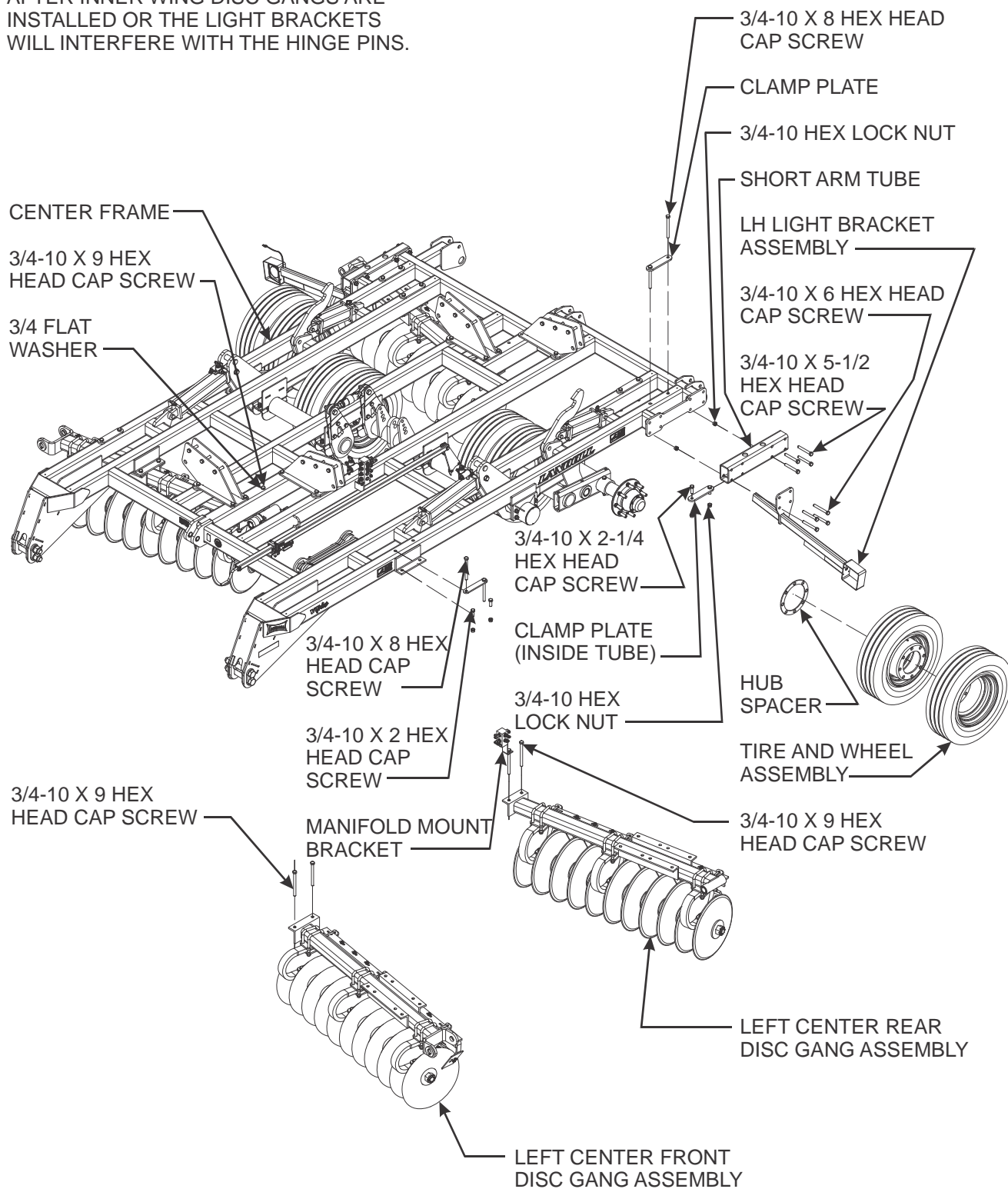

7450 center frame disc gang inst

Figure 3-1: Center Disc Gang Installation

Disc Gangs



DANGER

Disc blades are extremely sharp. Exercise extreme care when working on or near disc blades. Do not allow discs to roll over or fall onto any bodily part. Do not allow wrenches to slip when working near disc blades. Never push wrenches toward disc blades. Do not climb over machine above disc blades. Failure to stay clear of disc blade edges can cause serious personal injury or death.

1. Attach the disc gang assemblies to the center section using 3/4-10 x 2-1/4, 3/4-10 x 8, 3/4-10 x 9 grade 8 hex head cap screws, and hex lock nuts (See **Figure 3-1.**) Use a 3/4-10 x 9 grade 8 hex head cap screw, manifold mounting bracket, and hex lock nut on the center front screw of the left rear gang for all sizes.
2. Install a 1/2 x 2-1/4 grooved alloy pin in the end of each hinge pin.
3. Assemble each wing gang to the center frame gang using the hinge pin, 1-3/4 thrust washer, and 1-1/4-7 hex lock nut allowing the blades to sit on the ground.
4. Assemble rh/lh light brackets.

NOTE

The thrust washer is positioned on the rear side of the inner hinge on the front gangs, and on the front side of the inner hinge on the rear gangs.

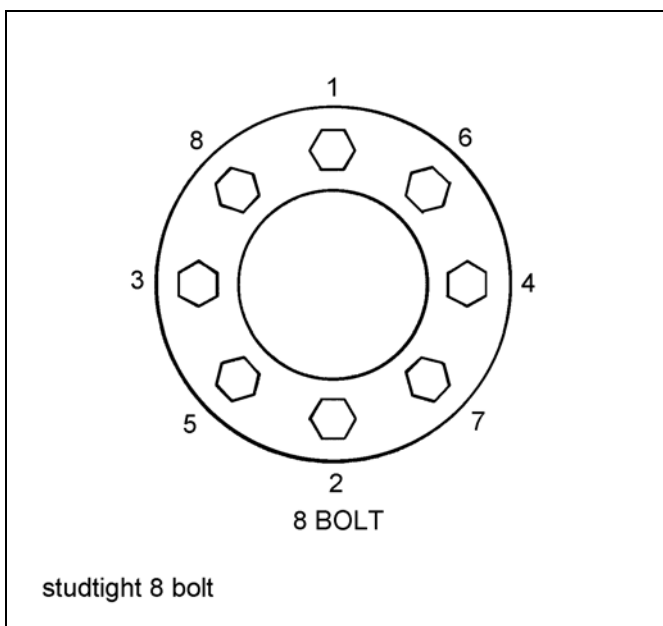

Figure 3-2: Stud Tightening Sequence

Mounting Center Frame Tires and Wheels

Install the tire and wheel assemblies on the center section. The center frame tires uses 235/75R17.5 tires with 8-bolt walking dual wheels and 4" slip-in spindles.

1. Make sure that all mounting surfaces are clean and free of rust, dirt or paint. A wire brush may be used to clean these surfaces (See **Figure 3-1.**)
2. Position the inner disc wheel over the studs, being careful not to damage the stud threads. Make sure that the disc wheel is flat against the mounting surface. There will be a wheel spacer on the hub and it needs to be mounted between the hub and the inner wheel.

NOTE

Do not put hub spacer between the wheels.

3. Position the outer disc wheel being careful not to damage the stud threads. Be sure the valve stems for both the inner and outer tire are pointing away from each other (facing outward). Align wheel holes when mounting.
4. Install the flange nut and tighten to 50 foot-pounds using the sequence in **Figure 3-2.** Then tighten to full torque of 450-500 ft./lbs.
5. Torque will drop after the first 10 hours of operation. Check the nuts for proper torque after this interval and retighten them.



WARNING

Use a torque wrench to assure proper torque. Insufficient torque can cause stud breakage and damage wheel pilots. Overtorque can overstress the studs and strip the threads.

NOTE

All tire/wheel assemblies are mounted with the valve stem facing outward.

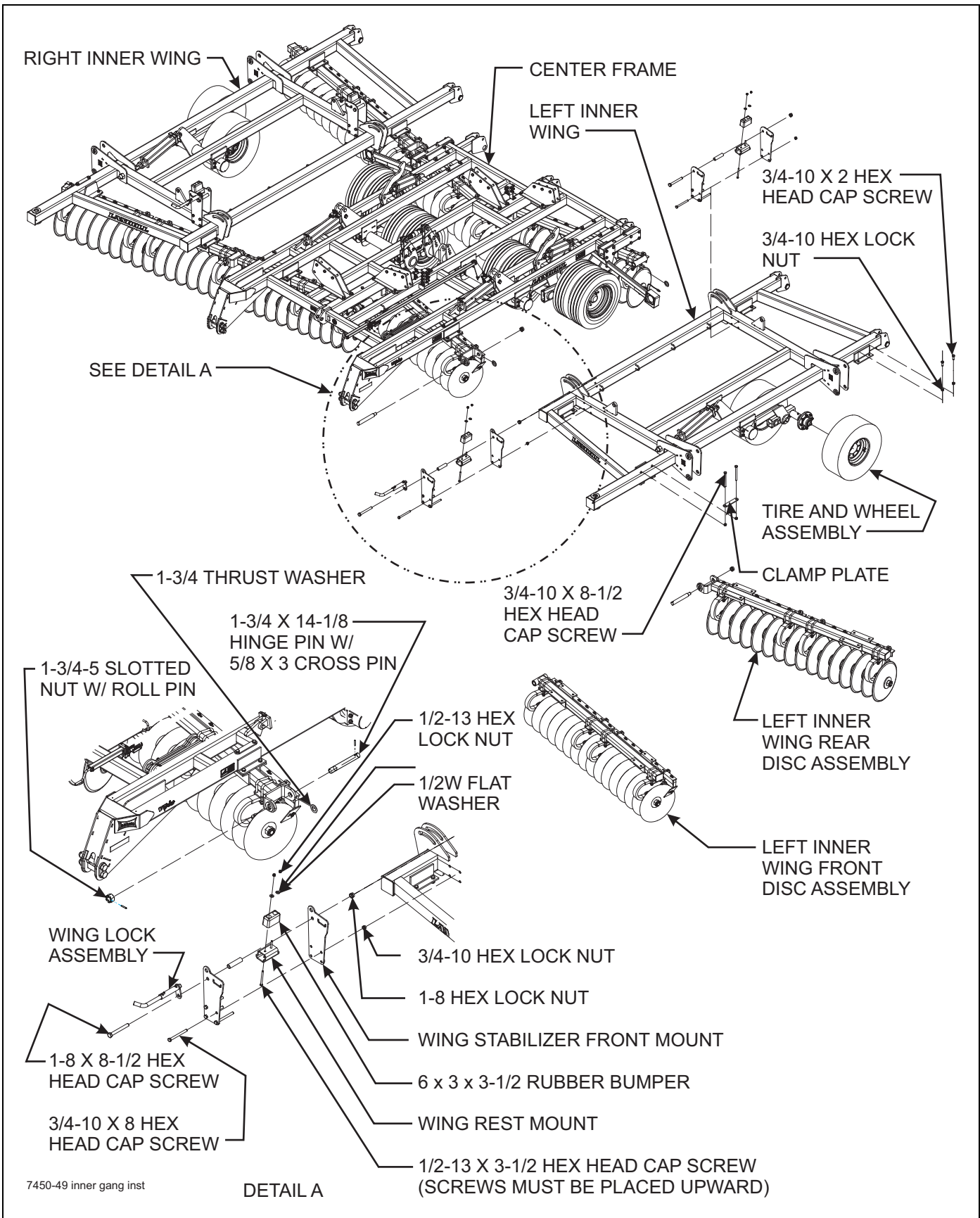

Figure 3-3: Inner Wing Frame Installation

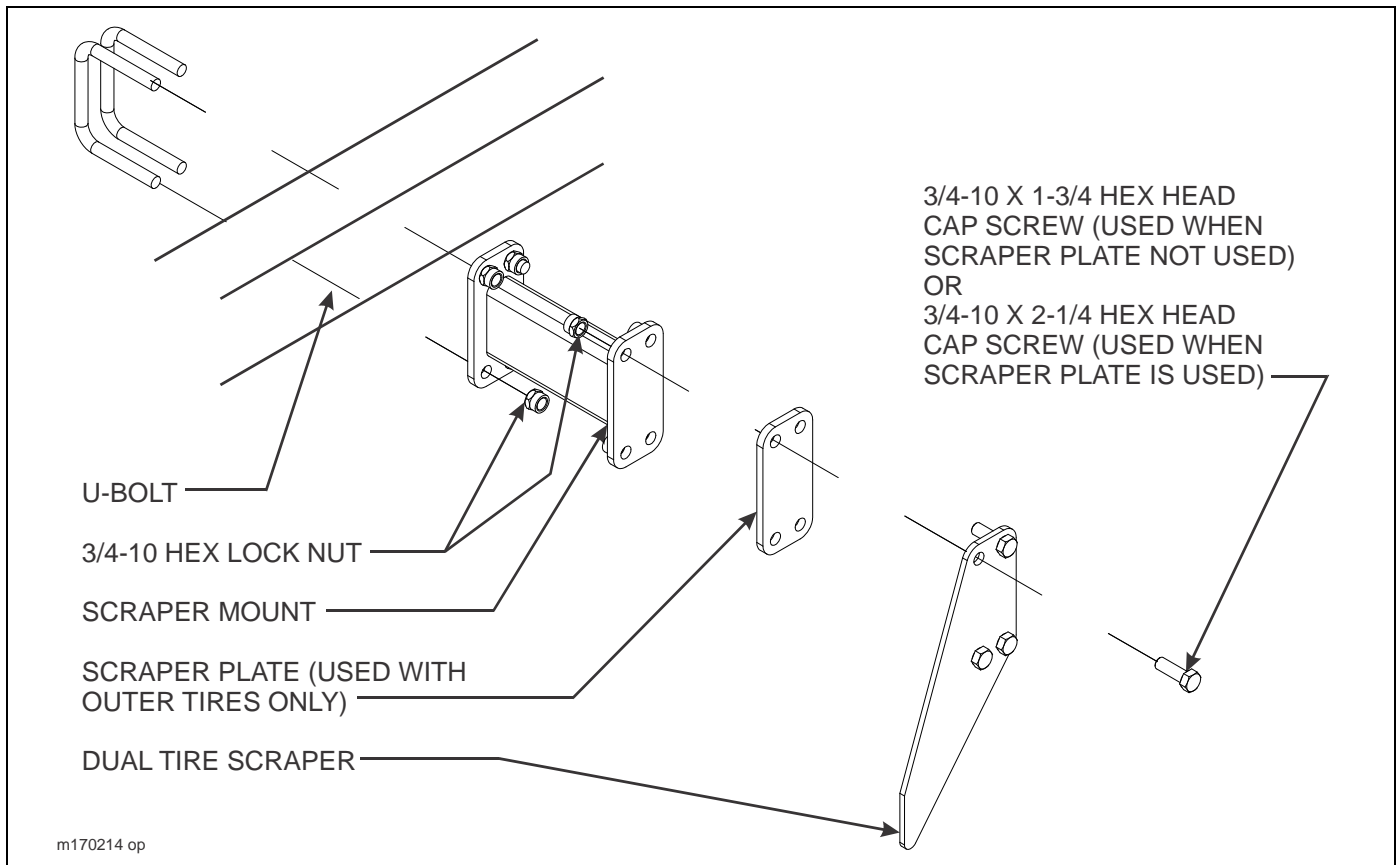

Figure 3-4: Dual Tire Scraper Installation

Dual Tire Scraper Installation

Refer to **Figure 2-13** for dual tire scraper placement.

1. Attach scraper mount to center frame using u-bolts and 3/4-10 hex lock nuts (**See Figure 3-4.**)
2. On inner dual tires, attach scraper to scraper mount in between dual tires using 3/4-10 x 1-3/4 hex head cap screws and hex lock nuts.
3. On outer dual tires, attach scraper to scraper mount in between dual tires using scraper plate, 3/4-10 x 2-1/4 hex head cap screws and hex lock nuts.

Inner Wing Frames

1. Place the inner wing frames on top of the wing gang assemblies and attach using 3/4-10 x 2 and 3/4-10 x 8-1/2 hex head cap screws and hex lock nuts (**See Figure 3-3.**)
2. Assemble the tire and wheel assemblies to the wing frames. The wings use 8 bolt wheels and 3" slip-in spindles. Torque to 85 to 100 ft./lbs.
3. Assemble wing stabilizer and wing lock as shown on the front and rear cross tubes.

IMPORTANT

Note the orientation as the rubber bumper must be toward the outside and the 1/2-13 x 3-1/2 hex head cap screws must be inserted from the bottom through the wing rest mount and rubber bumper and the flat washers and hex lock nuts located on top.

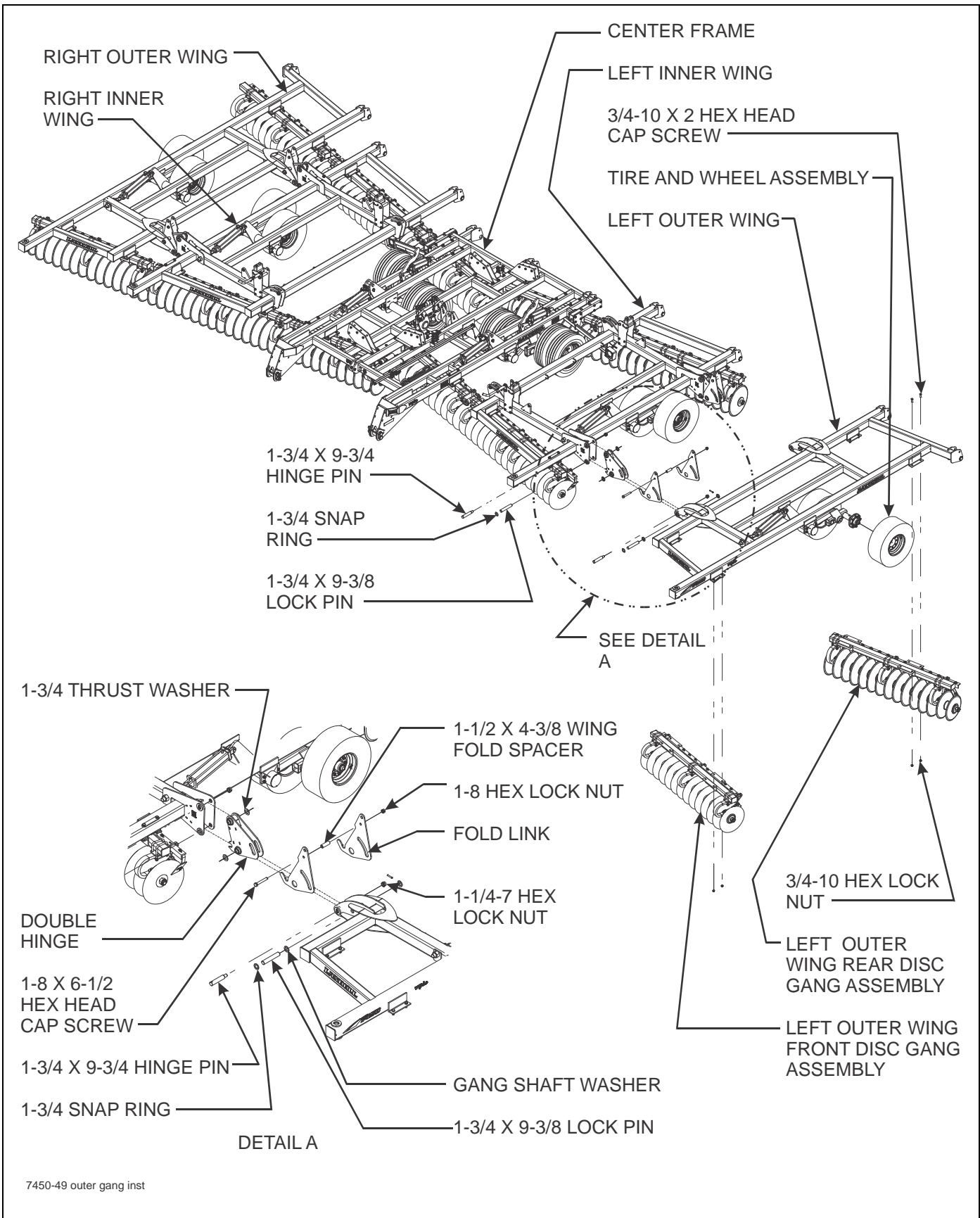

Figure 3-5: Outer Wing Frame Installation

Outer Wing Frames

1. Install double hinge and locks to inner wing with thrust washer toward rear of the machine using hinge pin and 1-1/4-7 hex lock nut (See Figures 3-5 and 3-7). Install two fold links per hinge, placing them over the bushing of the double hinge. Insert 1-8 x 6-1/2 hex head cap screw, wing fold spacer, and 1-8 hex lock nut to keep fold links stable while installing outer wing.
2. Attach outer wing with thrust washer toward front of machine (See Figure 3-5. thru 3-7.)
3. Assemble the tire and wheel assemblies to the wing frames. The wings use 8 bolt wheels and 3" slip-in spindles. Torque to 85 to 100 ft./lbs.

NOTE

All tire/wheel assemblies are mounted with the valve stem facing outward.

4. Install disc gangs to inner wing frames using 3/4-10 x 2 hex head cap screws and hex lock nuts.

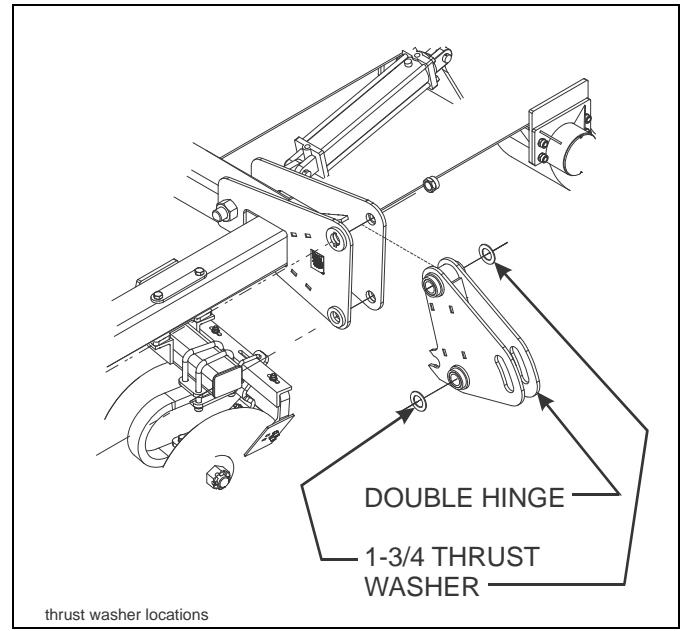

Figure 3-6: Thrust Washer Locations

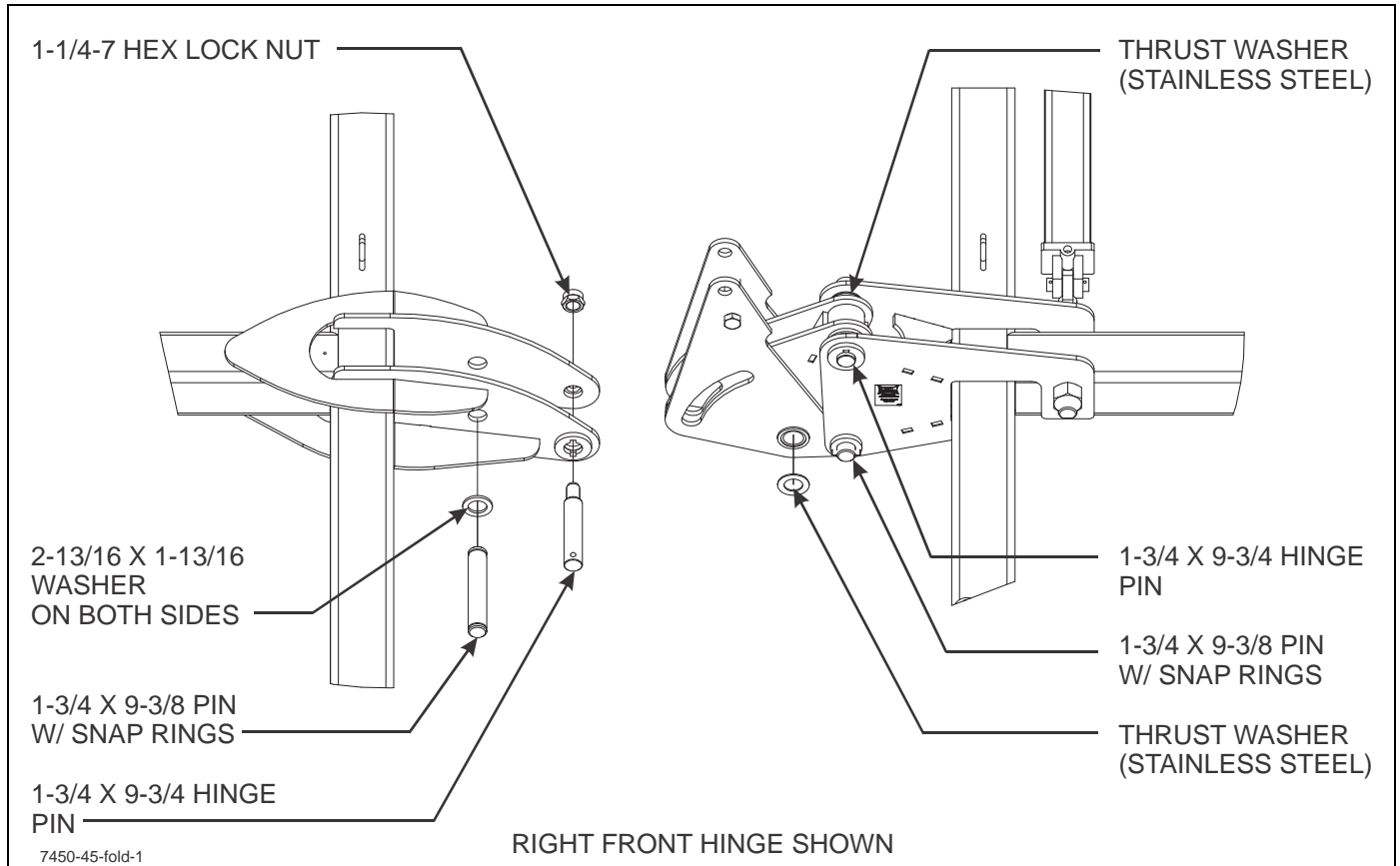
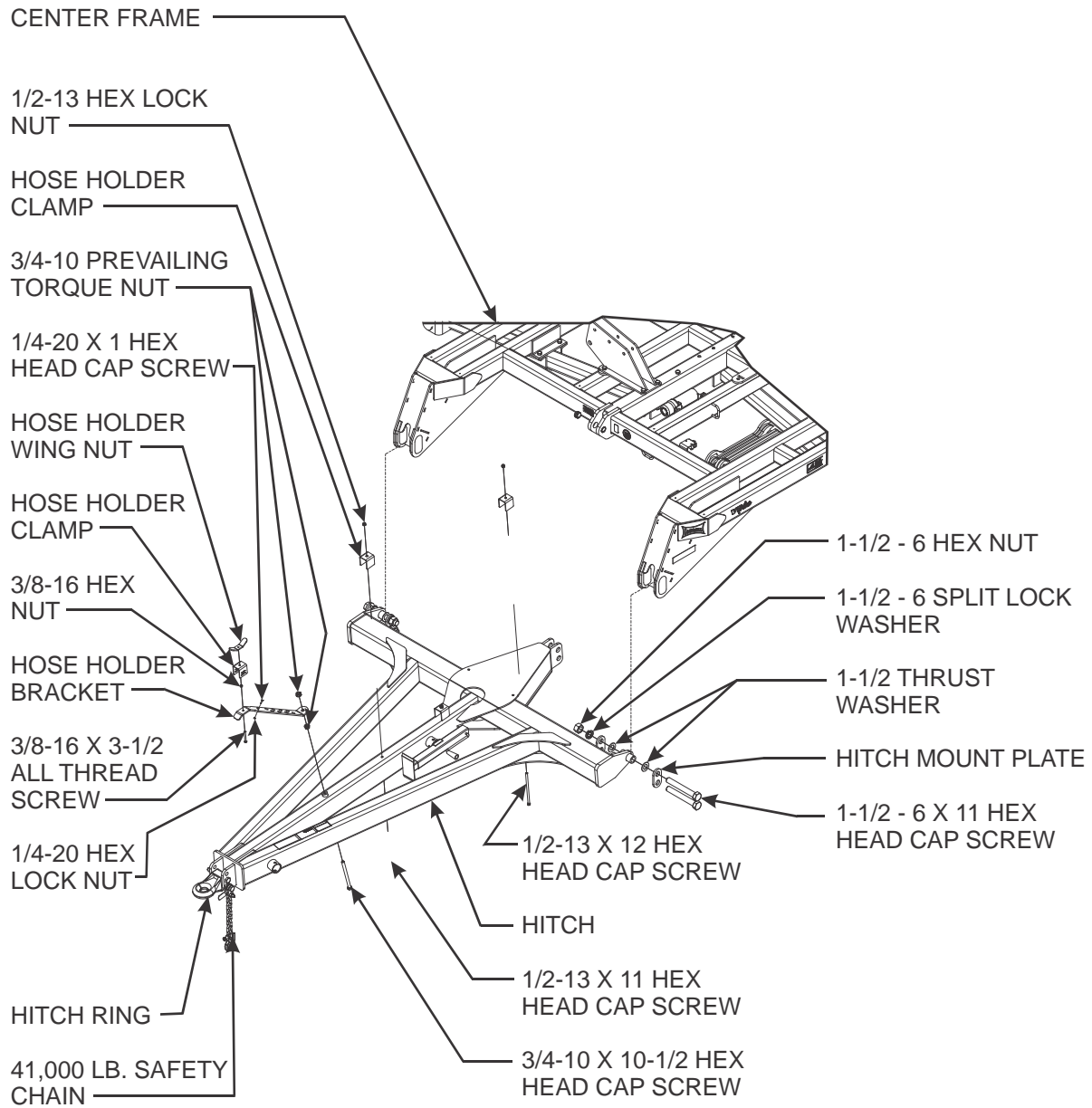

Figure 3-7: Outer Wing Frame Hinge Assembly



7450 frame and hitch assy

Figure 3-8: Frame and Hitch Assembly Installation

7450 VT Plus Frame and Hitch Assembly

IMPORTANT

Read all safety precautions at the front of the section before attempting any of the following procedures.



WARNING

Do not attempt to lift heavy parts (such as the frame, disc gangs, rock shaft, and pull hitch) manually. Use a hoist or a fork lift to move these parts into position.

1. Attach the hitch weldment to the front of the center frame using 1-1/2-6 x 11 hex head cap screws, 1-1/2 thrust washers, split lock washer, hitch mounting plates, and hex nuts (**See Figure 3-8.**)

NOTE

The hitch may be assembled in the upper or lower position depending on matching tractor drawbar height. See "Hitch Adjustment" on page 4-11 for proper adjustment.

2. Move the tongue jack to the forward mounting tube and rotate to parking position to support the front of the hitch.
3. Insert a 3/4-10 x 10-1/2 hex head cap screw into the hose holder tube on the hitch from the bottom side so the threads point upward. Hold in place with a 3/4 prevailing torque flange nut with the flange pointing upward as well. Do not tighten this cap screw, so the hose holder bracket may pivot freely in this joint.
4. Slide the hose holder bracket over the screw and secure with another 3/4 prevailing torque flange nut.
5. Install a 3/8-16 x 3-1/2 all-thread screw in the front of the hose holder bracket and secure with a 3/8-16 hex nut.
6. Slide the hose holder clamp over the 3/8" screw and loosely start the wing nut on top of the clamp. Hydraulic hoses will be routed through the clamp after assembly.

NOTE

The clamp has two sides, so that extend hoses can be located on one side and retract hoses can be located on the other side for reference.

7. Install 1/2-13 x 11 hex head cap screws and hose clamps until the hoses are routed through them.
8. Loosely install 1/2-13 x 12 hex head cap screws and hose clamps until the hoses are routed through them.

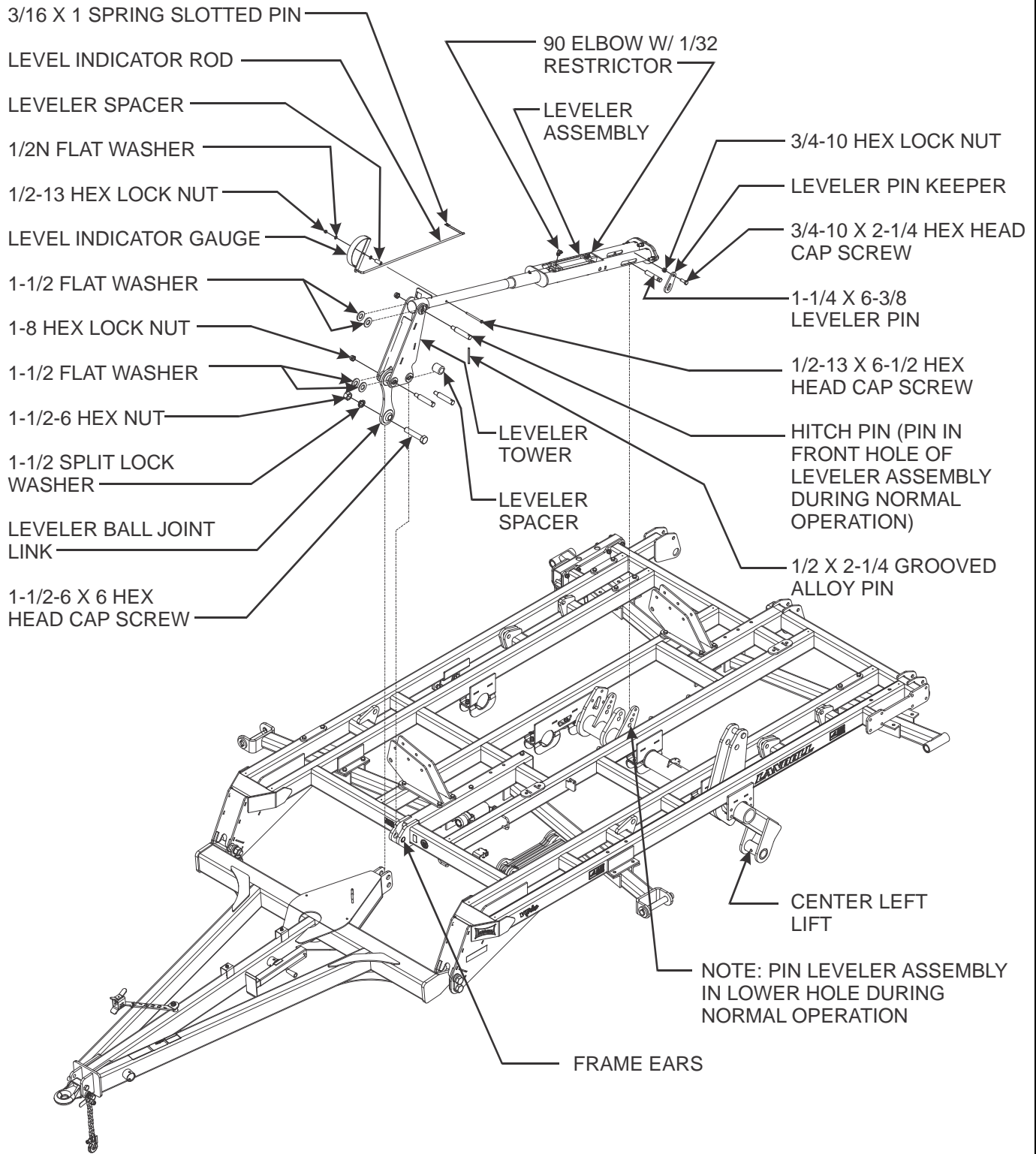

7450-49-leveler op

Figure 3-9: Leveler Assembly Installation

Leveler Assembly

1. Attach rear of leveler assembly to the center left lift using the leveler pins through the leveler base/cross.

NOTE

For normal operation of VT Plus, use the lower set of cross holes to mount the leveler assembly to the center left lift.

2. Slip the leveler pin keeper over the leveler pin hole and slide up into place so that the slots in the leveler pin sit firmly in the straight sides of the keyhole. This will be done on both sides of the leveler assembly.
3. Connect the top of the leveler pin keeper to the second hole from the top of the center lift leveler mount plate using a 3/4-10 x 2-1/4 hex head cap screw and hex lock nut.
4. Attach leveler tower to the center frame using a hitch pin, leveler spacer, 1/2 x 2-1/4 grooved alloy pin, and 1-8 hex lock nut.

NOTE

The leveler spacer is located between frame ears.

5. Attach the top of the leveler tower to the leveler assembly with hitch pin, 1/2 x 2-1/4 grooved alloy pin, 1-1/2" washers, and 1-8 hex lock nut.

NOTE

For normal operation use the mounting hole on the end of the leveler tube. Drawbars of 17" or less could require the 2nd hole in.

6. Attach leveler tower to the top of the leveler ball joint link with hitch pin, 1/2 x 2-1/4 grooved alloy pin, (2) 1-1/2" washers, and 1-8 hex lock nut.
7. Attach the leveler ball joint link to the lower hole of the lower hole of the hitch plate with a 1-1/2-6 x 6 hex head cap screw, split lock washer, and hex nut (**See Figure 3-9.**)

NOTE

*When the hitch is in the upper mounting position, the leveler ball joint link is mounted in the lower holes. When the hitch is in the lower position, the link is mounted in the top mounting holes. **See "Hitch Adjustment" on page 4-11** for proper adjustment.*

8. Place 3/16 x 1 spring slotted pins into two holes in the level indicator rod. Slide the level indicator rod into the hole in the end of leveler base so that the first pin is inside the leveler base. Rotate the level indicator rod so that the pins hold the rod in place.
9. Connect the level indicator gauge to the tube leveler assembly using 1/2-13 x 6-1/2 hex head cap screw, leveler spacer, flat washers, and hex lock nut.
10. Place short end of bent rod through level indicator gauge and hold in place with a hairpin.
11. Install (2) 90 elbows w/ 1/32" restrictors. Note that only two are supplied with the machine.

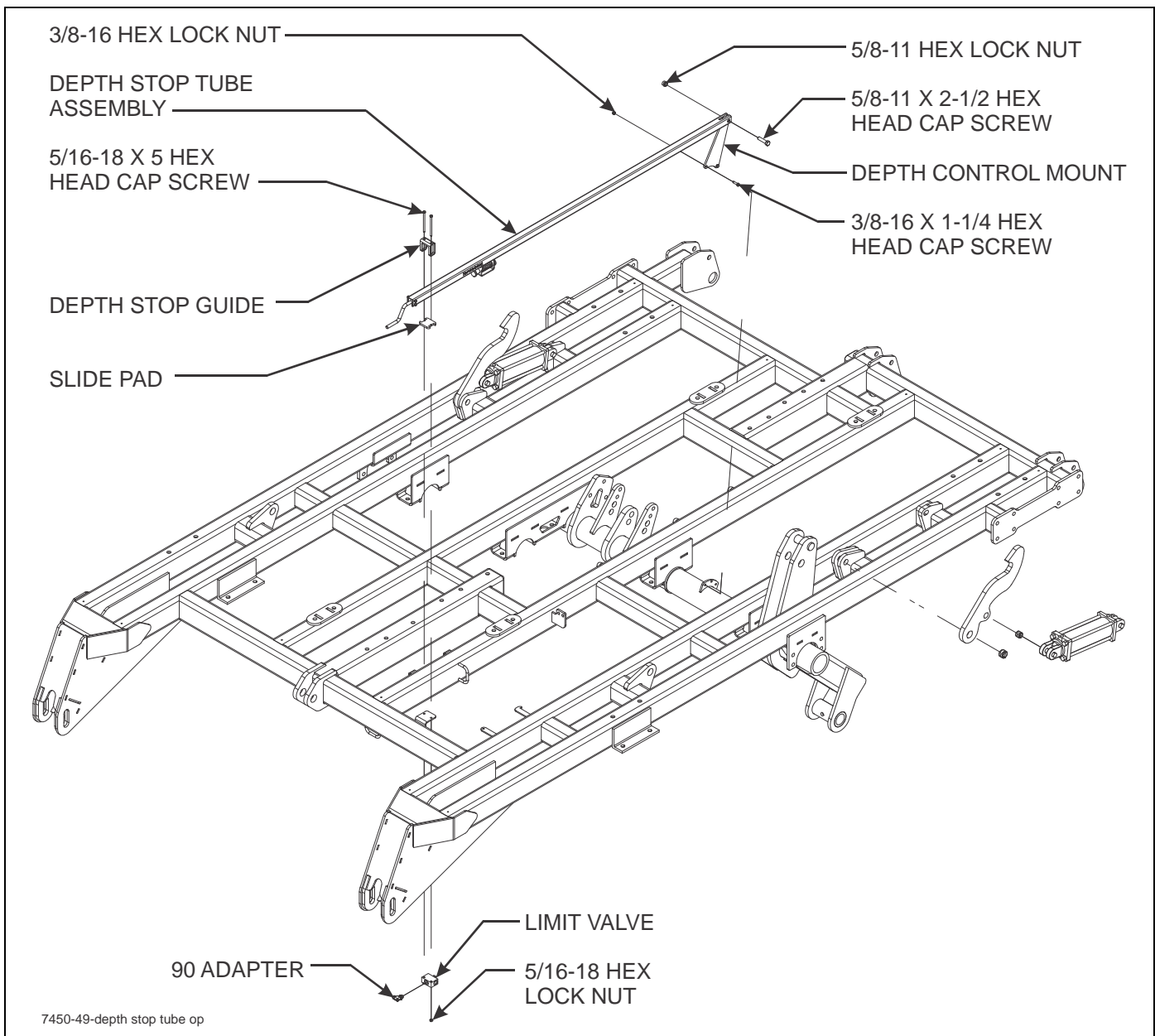

Figure 3-10: Depth Stop Tube Installation

Depth Stop Tube Installation

1. Attach the depth control mount plate to the lift using 3/8-16 x 1-1/4 hex head cap screws and hex lock nuts.
2. Lay the depth stop tube assembly on top of the center frame. Insert a 5/8-11 x 2-1/2 hex head cap screw in the rear hole of the tube assembly from the left side (**See Figure 3-5.**) Install a 5/8-11 hex nut on the screw. Do not over tighten, as the depth stop must pivot on this screw. Insert the screw through the depth stop mounting plate on the center lift and secure with a 5/8-11 hex lock nut.
3. Insert 90° elbow fitting in the front of the limit valve.
4. Using 5/16-18 x 5 hex head cap screws secure the front end of the depth stop tube assembly to the top of the frame mount with the depth stop guide, slide pad, and 5/16-18 hex lock nuts. Attach the limit valve to the bottom side of the center frame mount using these same screws.

IMPORTANT

It may be necessary to leave these screws loose to attach the valve hoses later.

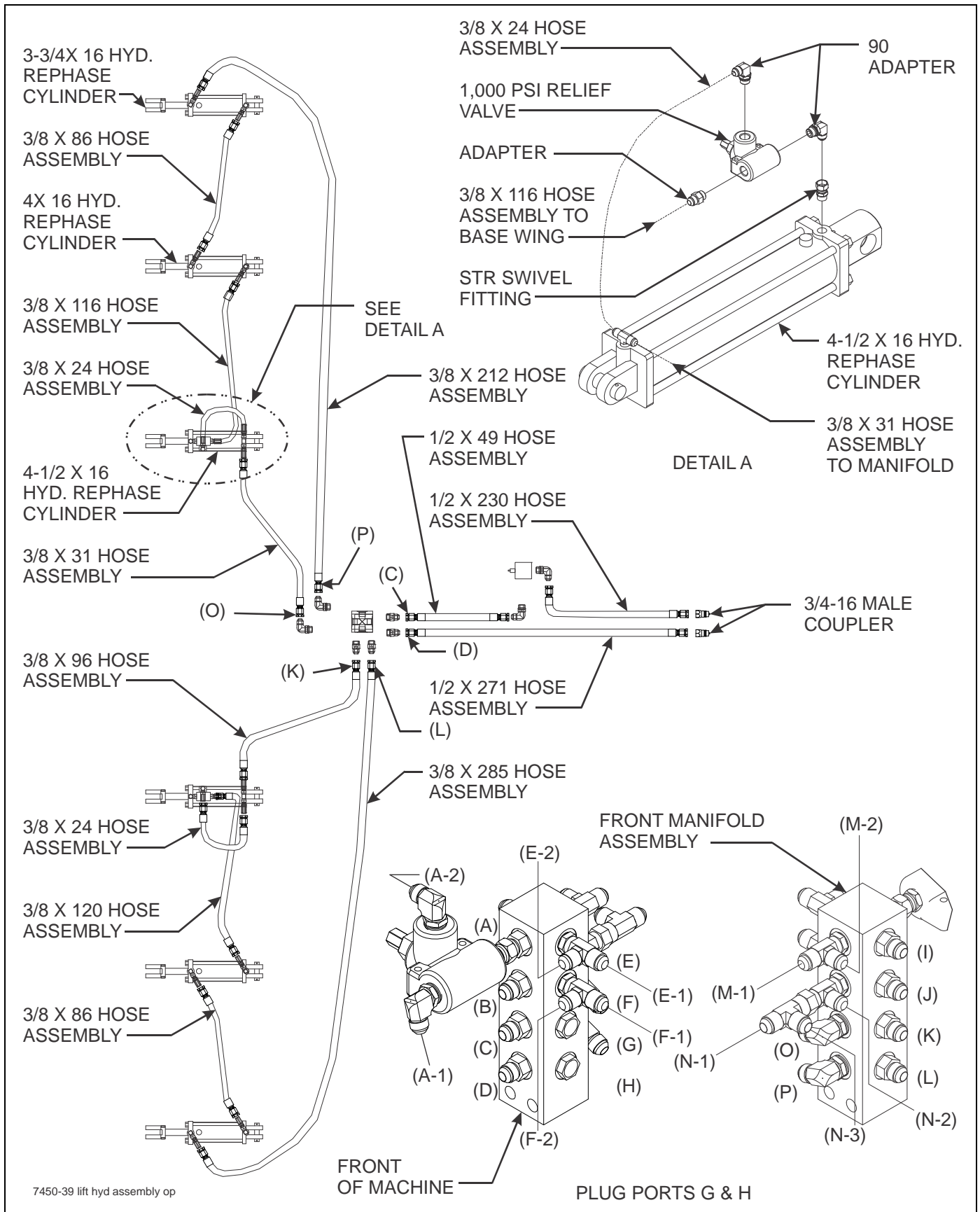

Figure 3-11: Lift Hydraulic Installation (39' Model)

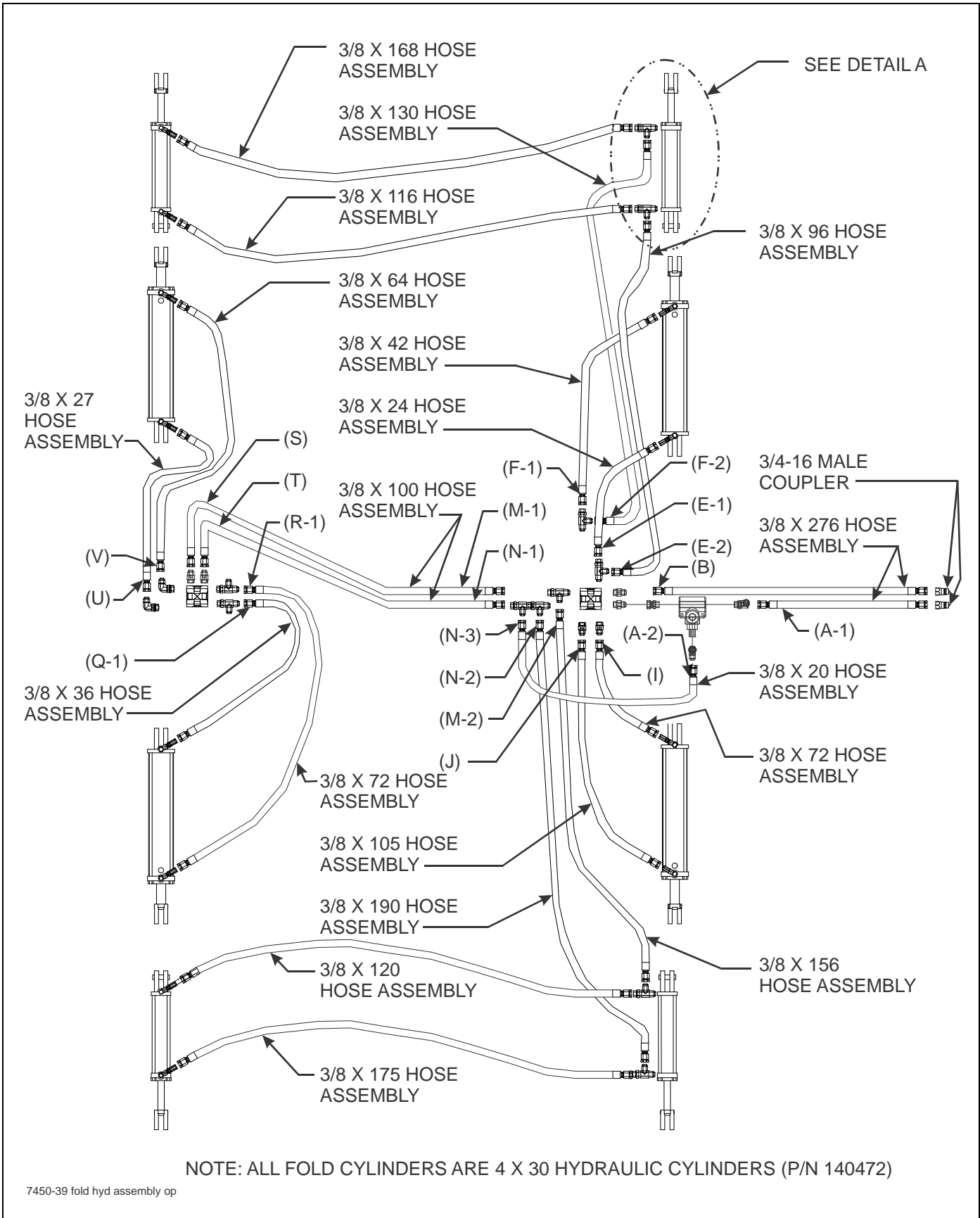

Figure 3-12: Fold Hydraulic Installation (39' Model)

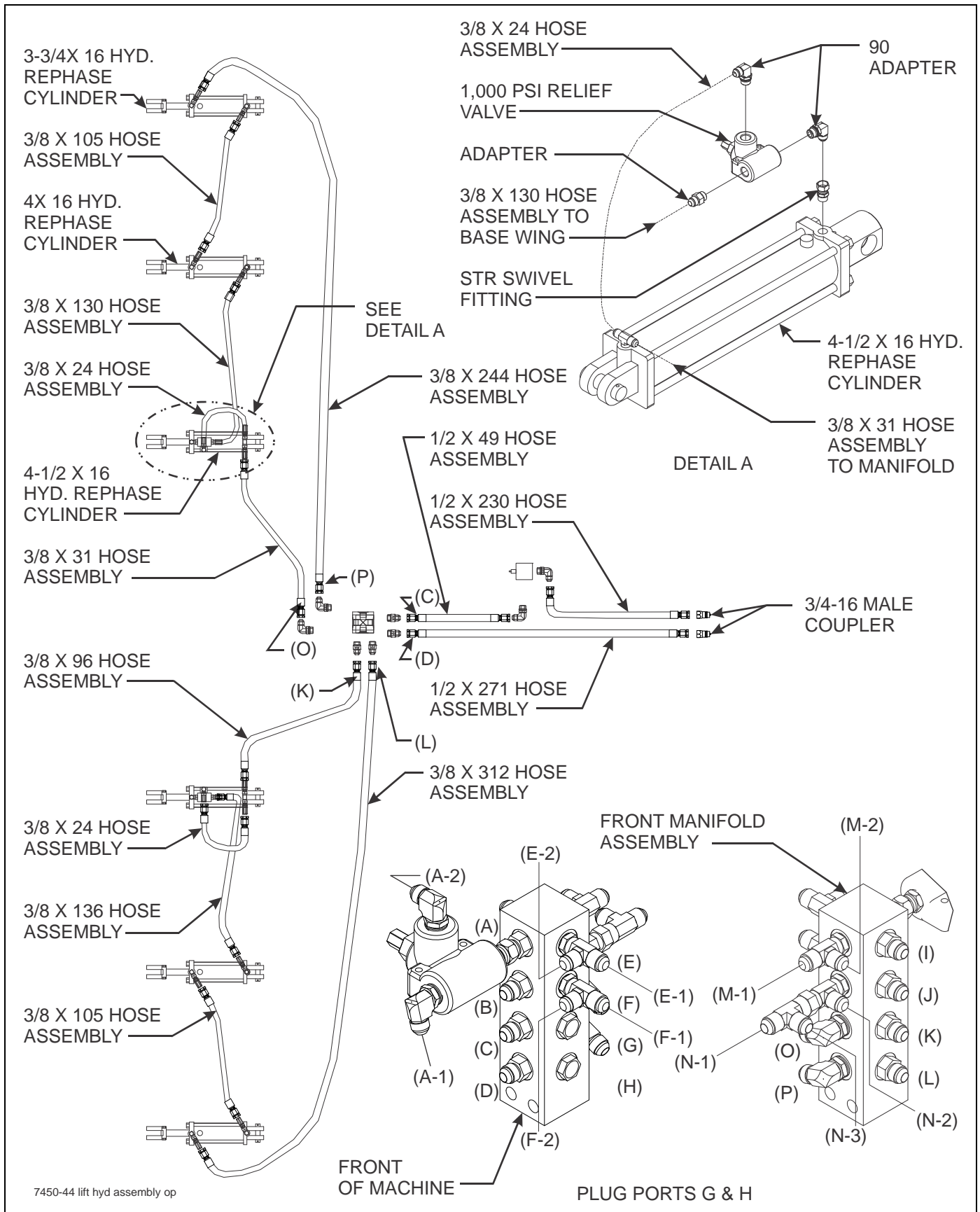

Figure 3-13: Lift Hydraulic Installation (44' Model)

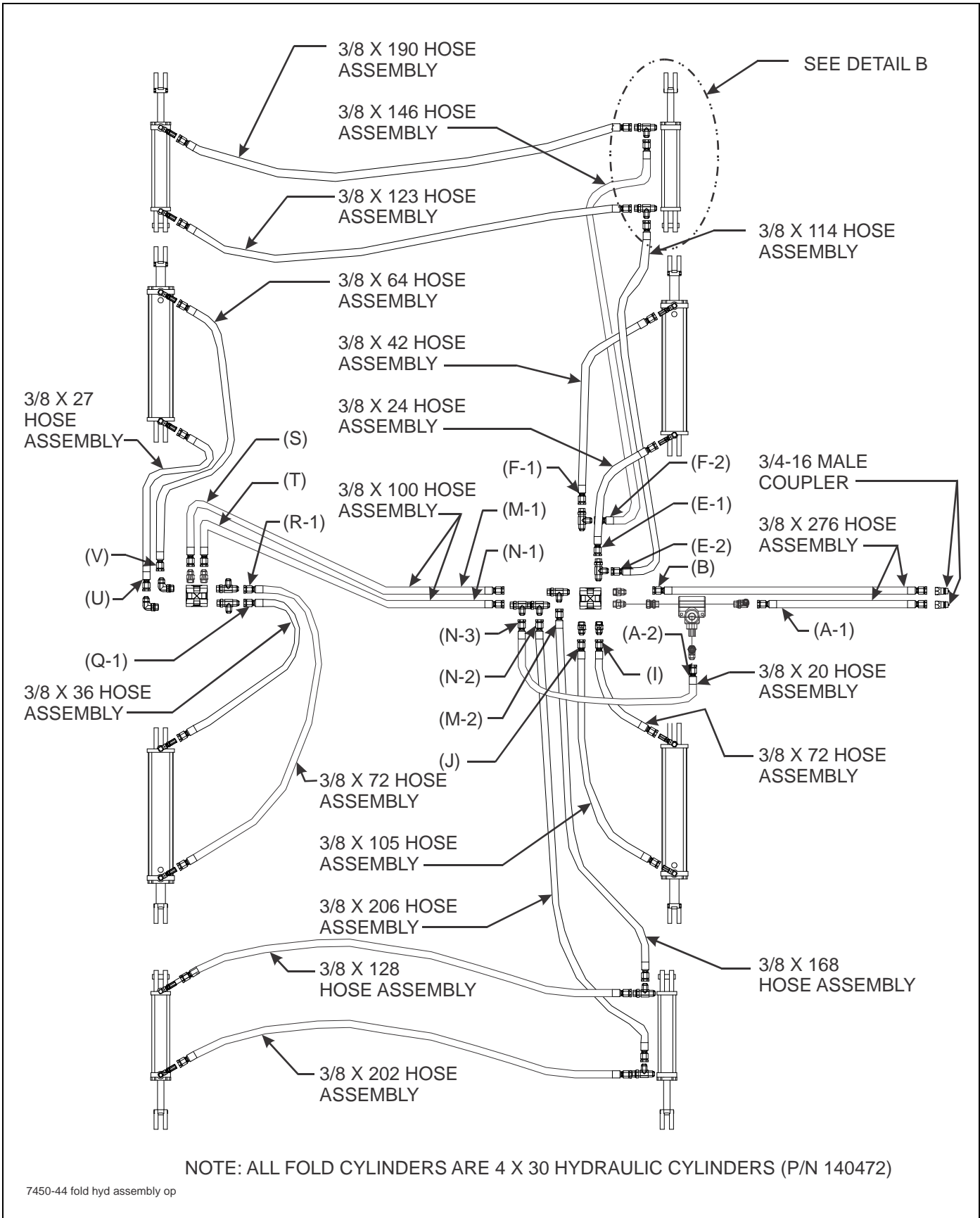

Figure 3-14: Fold Hydraulic Installation (44' Model)

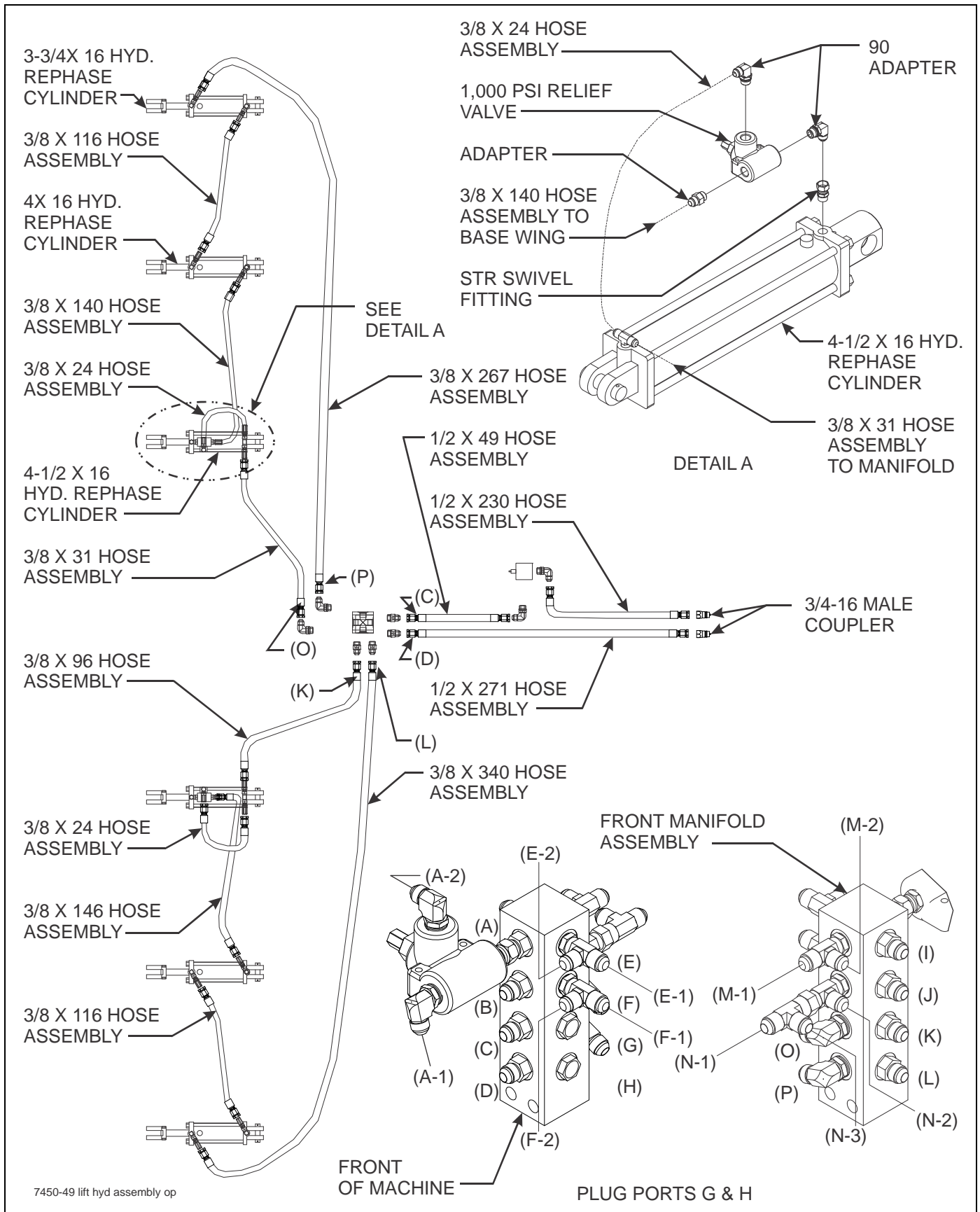

Figure 3-15: Lift Hydraulic Installation (49' Model)

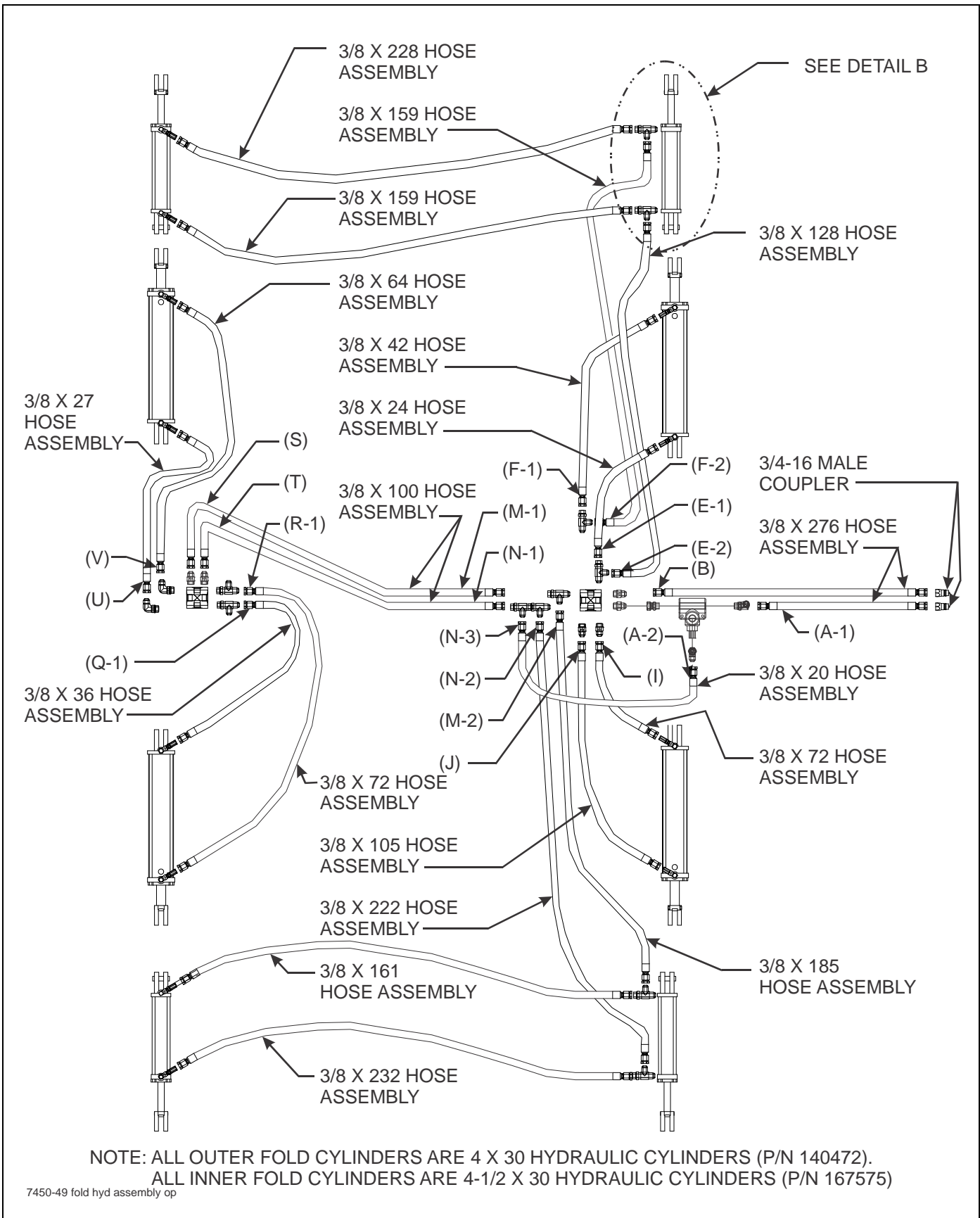

Figure 3-16: Fold Hydraulic Installation (49' Model)

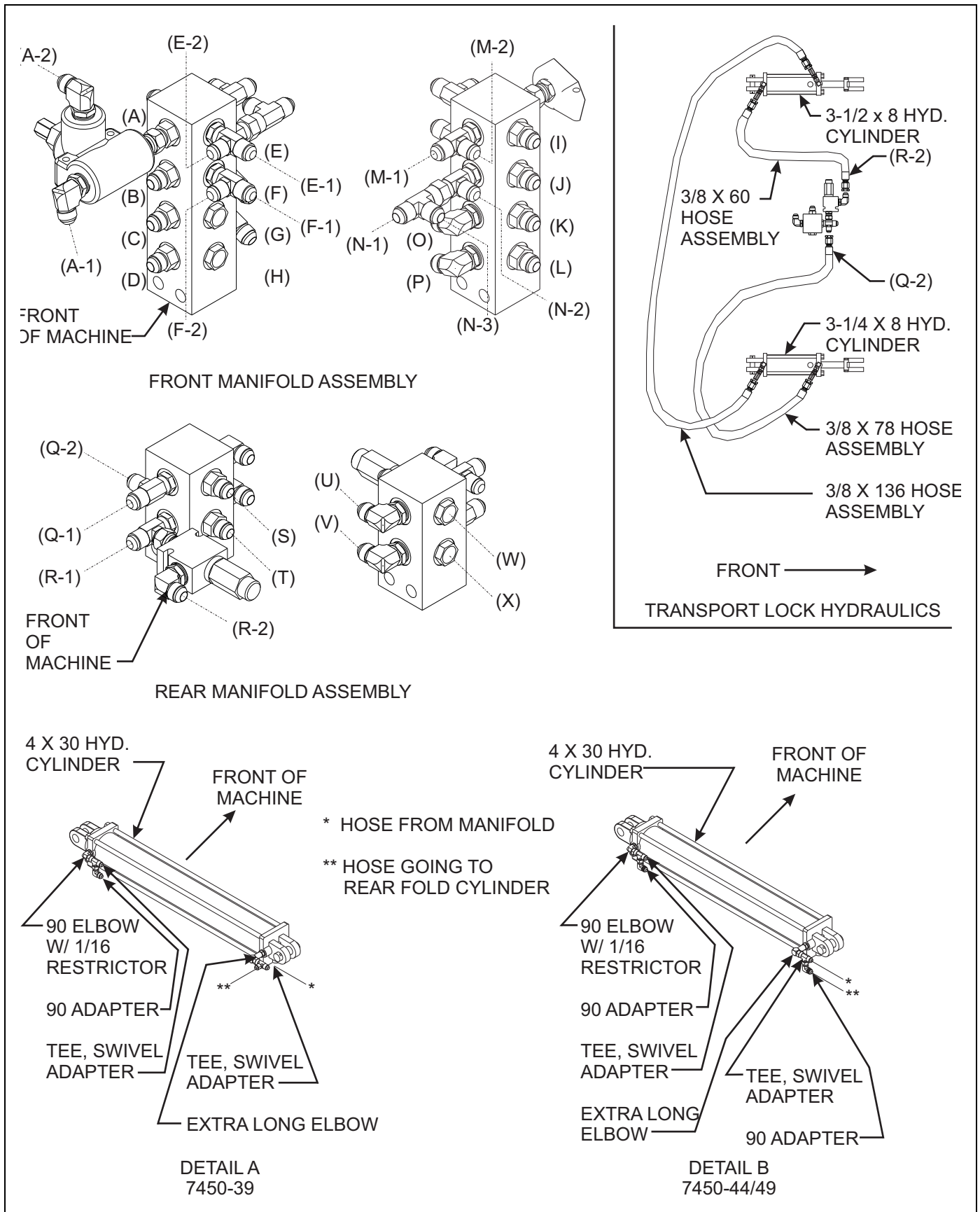

Figure 3-17: Transport Lock and Fold Hydraulic Assembly Details

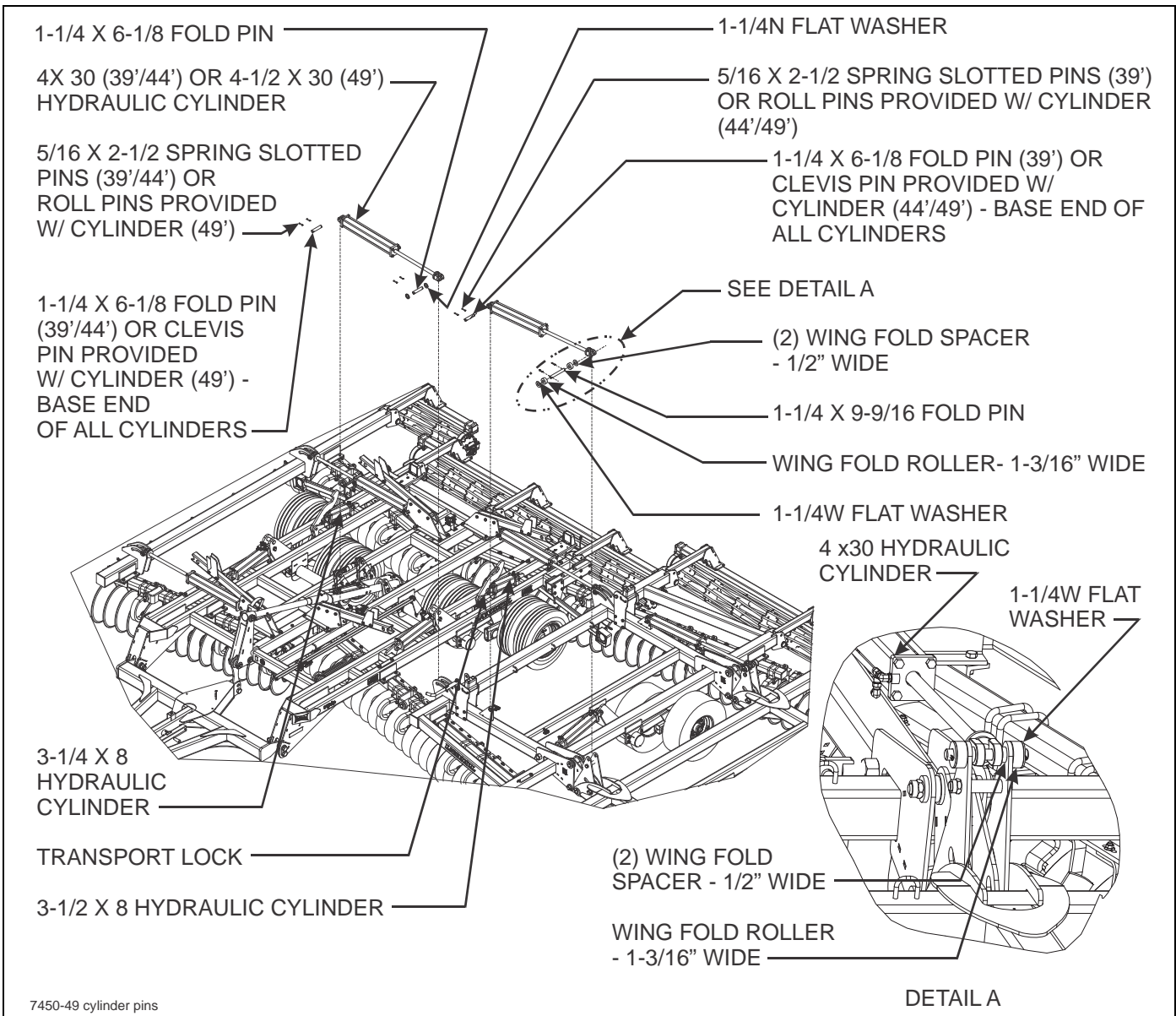

Figure 3-18: Fold Hydraulic Assembly

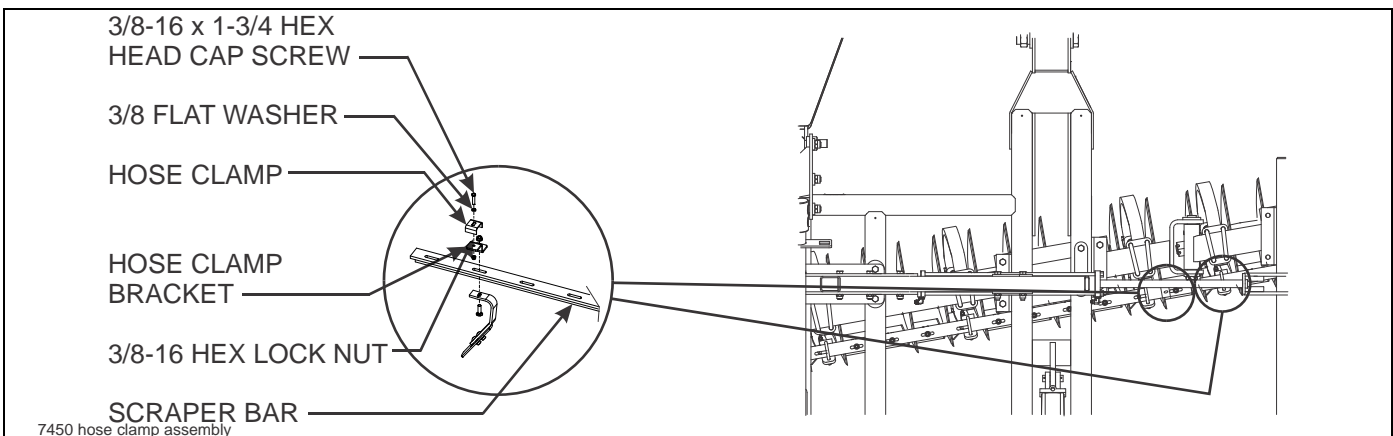

Figure 3-19: Hose Clamp Assembly

Hydraulic Installation

NOTE

See Figures 3-11 through 3-16 for hydraulic cylinder fittings (factory installed and those installed during setup).

Refer to Figures 3-11- 3-12 for lift and fold hydraulic diagrams for 7450-39' model.

Refer to Figures 3-13- 3-14 for lift and fold hydraulic diagrams for 7450-44' model.

Refer to Figures 3-15 - 3-16 for lift and fold hydraulic diagrams for 7450-49' model.

Refer to Figure 3-17 for transport lock hydraulic diagram, front and rear manifold drawings, and fold cylinder detail for all models.

1. Attach the base end of the 4 x 30 (7450-39'/ 7450-44') or 4-1/2 x 30 (7450-49') fold cylinder to the fold cylinders mounts on the center frame with the pins and roll pins as designated in **Figure 3-18**. Position the cylinders so the hydraulic ports point to rear on front and to front on the rear and toward the center of machine.
2. Using a 1-1/4 x 6-1/8 fold pin, flat washers, and 5/16 x 2-1/2 roll pins, attach the rod end of the 4" x 30" cylinders to the slotted mounts on the inner wing frames (See **Figure 3-18**.)
3. Using 1-1/4 x 6-1/8 fold pin (7450-39') or pins provided with cylinder (7450-44'/7450-49'), attach base of outer wing fold cylinder to mount on inner wing (See **Figure 3-17**.)
4. Using a 1-1/4 x 9-9/16 fold pin, flat washers, wing fold rollers, wing fold spacers, and 5/16 x 2-1/2 roll pins, attach the rod end of the 4" x 30" cylinders to the fold links on the double hinge (See **Figure 3-18**.)
5. Install 90 degree regular adapter fittings in both ends of all lift cylinders and transport lock cylinders (4-1/2 x 16, 4 x 16, 3-3/4 x 16, 3-1/2 x 8, and 3-1/4 x 8).
6. Install the 16 port front manifold to the manifold bracket on the front of the center frame using 1/2-13 x 3-1/2 hex head cap screws and hex lock nuts.
7. Attach the 8 port manifold to the rear manifold bracket on the implement using 1/2-13 x 3-1/2 hex head cap screws and hex lock nuts. Install lift system hoses per **Figures 3-11 and 3-15**. Wrap lift system hoses with blue hose wrap.
8. Attach hose clamp brackets to the scraper bar (See **Figure 3-19**.) Secure hoses to the brackets with hose clamps, 3/8-16 x 1-3/4 hex head cap screws, and hex lock nuts.
9. Install fold system hoses per **Figures 3-12 and 3-16**. Wrap fold system hoses with yellow hose wrap.
10. Install 1/32" restrictors, (2) 3/10" hoses, and couplers in the hydraulic leveler. Wrap hydraulic leveler hoses with black hose wrap.
11. Attach outer wing stops and wing stabilizer to fold stabilizer mount using 3/4-10 x 5 hex head cap screws and hex lock nuts (See **Figure 3-20**.)

NOTE

Rod ends of fold cylinders need to be left unassembled until fold hydraulic system is fully charged with oil to prevent machine damage.

5. Install 90 degree regular adapter fittings in both ends of all lift cylinders and transport lock cylinders (4-1/2 x 16, 4 x 16, 3-3/4 x 16, 3-1/2 x 8, and 3-1/4 x 8).



CAUTION

1/16" Restrictors are installed in the rod end of wing fold cylinders to prevent uncontrolled dropping of wings. Removal of these restrictors, or improper installation can result in serious damage to the implement.

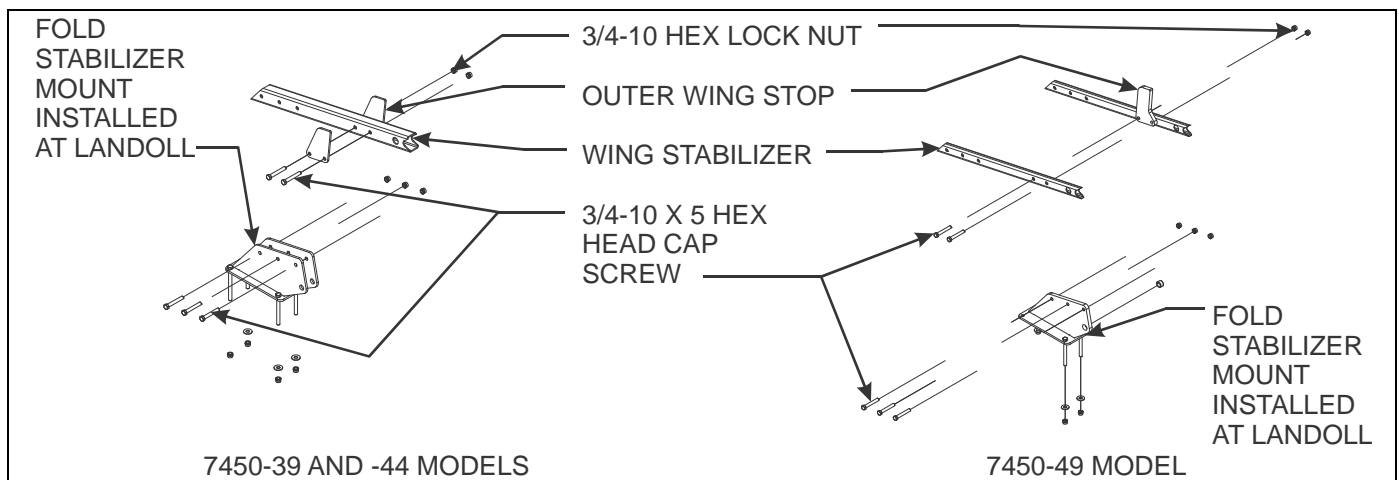

Figure 3-20: Wing Stabilizer Bracket Mounting Installation

7-PIN CONN	4-PIN TOWER	CIRCUIT	WIRE COLOR
1	D	GROUND	GROUND
2		WORK LAMPS	BLACK
3	B	LEFT FLASHING & TURN	YELLOW
4		STOP LAMPS	RED
5	A	RIGHT FLASHING & TURN	GREEN
6	C	TAIL LAMPS	BROWN
7		SWITCHED POWER (12V)	BLUE

	1 2-PIN TOWER	2 3-PIN TOWERS	3 6-PIN SHROUD	4 3-PIN TOWER	5 2-PIN TOWER
BLACK LEFT TURN			A	C	
WHITE GROUND	A	A	B	A	A
BROWN TAIL LIGHT		B	C	B	
YELLOW LEFT TURN			D		B
GREEN RIGHT TURN	B		E		
RED RIGHT TURN		C	F		

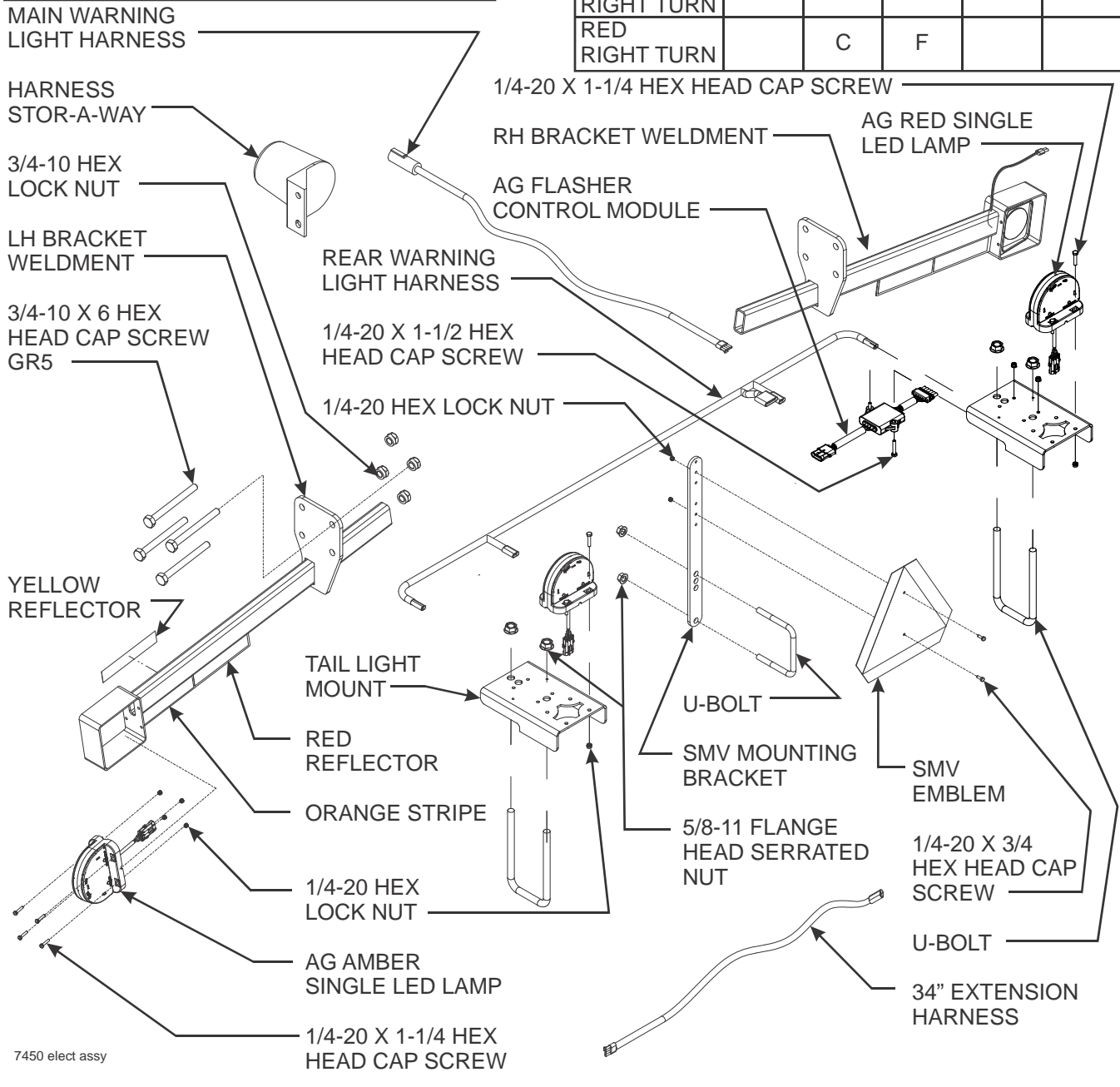

Figure 3-21: Light and SMV Bracket Installation

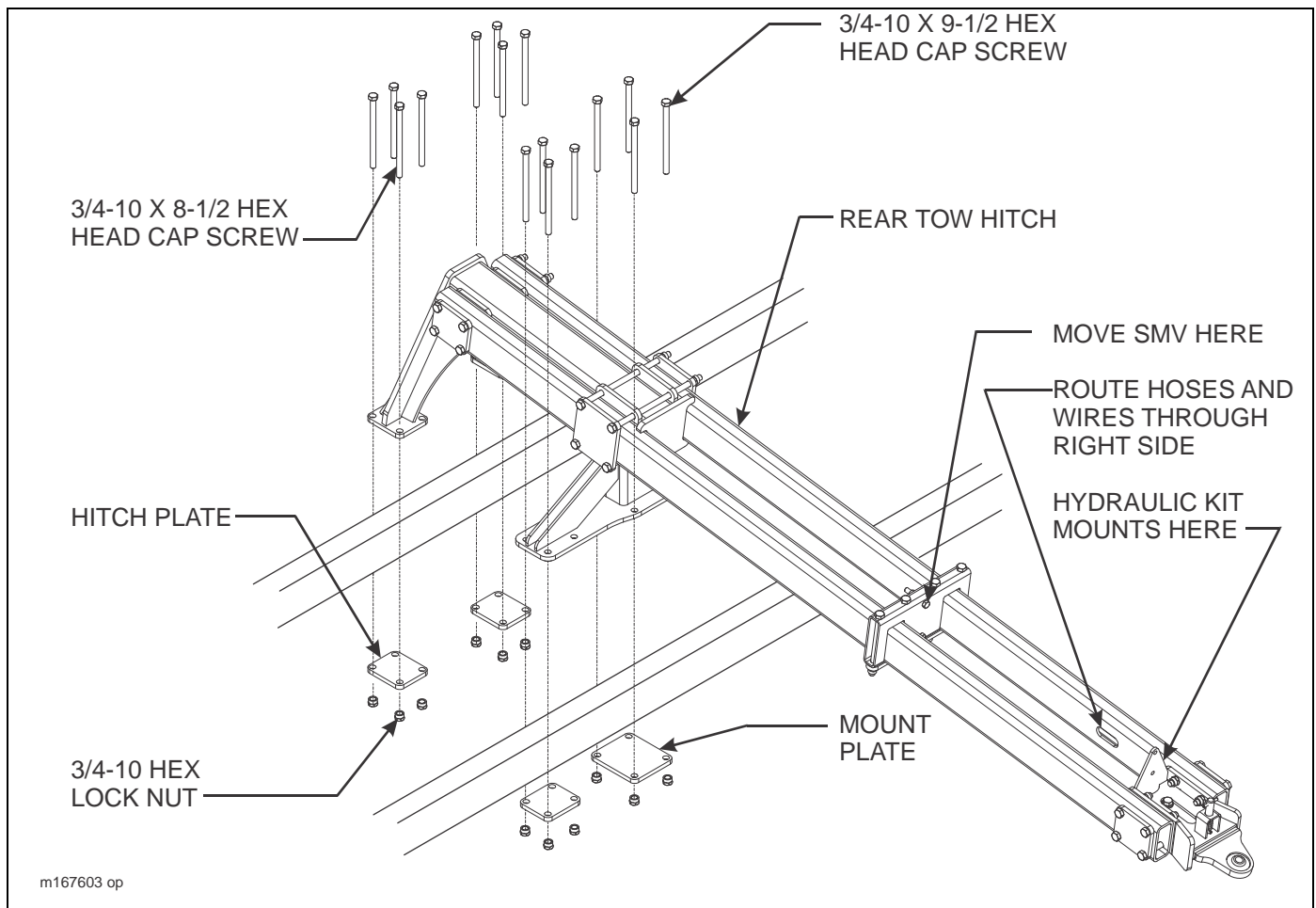

Figure 3-22: Rear Tow Hitch Installation

Light Installation

1. Attach lights and mounting brackets to the center frames using u-bolts, 3/4-10 x 6 hex head cap screws, and hex lock nuts (**See Figure 3-21.**) Refer to page 2-6 thru page 2-11 for light bracket placements.
2. Mount ag flasher control module on right hand tail light mount using 1/4-20 x 1-1/2 hex head cap screws and nuts. Connect rear harness to module and connect the right/left side lights accordingly. Route main wire harness through hose holder on hitch, down the left side of the center frame and across the back to the ag flasher control module plug.
3. Connect light harness to lights.
4. Attach SMV emblem and mounting bracket to rear center frame bar using u-bolt, 1/4-20 x 3/4 hex head cap screws, and hex lock nuts. The SMV sign should be mounted as shown in light bracket placements (**See Figures 2-1 thru 2-6.**)

Rear Tow Hitch Installation

Refer to **Figure 2-14** for rear tow hitch placement.

1. Attach rear tow hitch assembly to center frame using hitch plates, mount plate, 3/4-10 x 8-1/2 hex head cap screws, 3/4-10 x 9-1/2 hex head cap screws, and 3/4-10 hex lock nuts (**See Figure 3-22.**)
2. Move SMV from frame to rear tow hitch as shown.
3. If hydraulics are used, route through right side of hitch tube.
4. Connect one 34" extension harness from main warning light harness to rear tow tandem adapter harness. Connect other 34" extension harness from other connector on rear tow tandem adapter harness to the ag flasher control module. Route extensions through right side of rear tow hitch (**See Figure 3-21.**)

Conditioner Reel Installation

NOTE

Refer to *Conditioner Single Reel Installation* shown in **Figure 3-24** for single reel installation or *Conditioner Double Reel Installation* shown in **Figure 3-25** for double reel installation.

1. Assemble 1 x 8 adjustment bolt through adjustment pin on frame, 1" lock washer, (2) 1-8 hex nuts, and 17" heavy spring assembly. On the outer wings, remove one snap ring and slide large slot of reel arm stop over adjustment pin. Replace snap ring before installing the 1 x 8 adjustment bolt. The reel arm stop will be in between the plates welded to the frame, but mounted to the outer end of the reel.
2. Install 1-1/2" flange bearing into reel arm. Slide in 1-1/2" pivot bushing.
3. Attach reel arm to upper hole on rear center or wing frame or double mount using 1-8 x 6-1/2 hex head cap screw and hex lock nut.
4. Assemble 17" heavy spring assembly to reel arm using 1" pivot pin, and 5/16 x 1-1/2" spring slotted pins. Set pin centers to 21" dimension as shown in **(Figure 3-24)**. On the outer wings, the reel arm stop will replace the machinery bushing on the outside of the reel arm **See (Figure 3-23)**. This will prevent the outer reels from hanging down so far while the machine is being folded. **Refer to pages 2-6 thru 2-17** for reel arm stop locations.



WARNING

Do not attempt to lift heavy parts (such as the frame, disc gangs, lift, pull hitch, or reel/gang bar assembly) manually. Use a hoist or a forklift to move these parts into position.

5. Attach reel/gang bar assembly to reel arms using gang bar mount plate, 3/4-10 x 6 hex head cap screws and double hex lock nuts. **Refer to pages 2-6 thru 2-11** for reel gang bar placement locations.
6. Attach yellow reflector decals on outer arms **(See Figure 3-30.)** The decals are located in the manual tube. Reflector decal locations also shown on **pages 2-6 thru 2-17**.

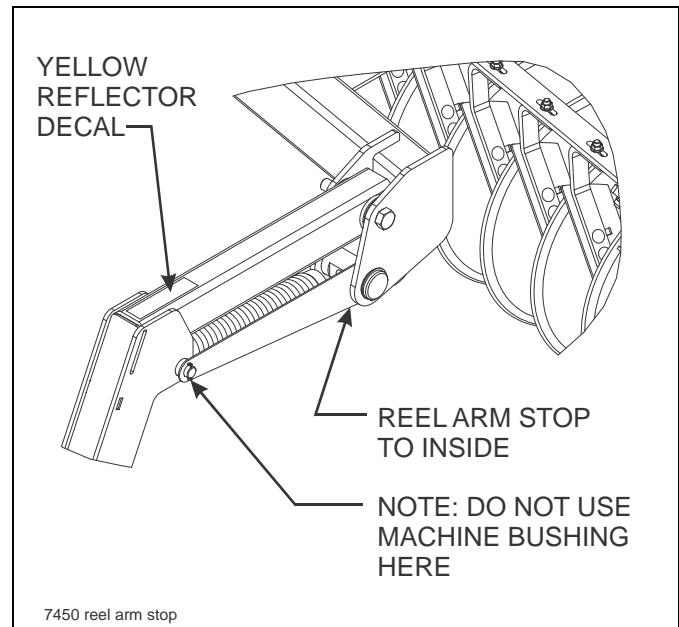

Figure 3-23: Conditioner Reel Arm Stop

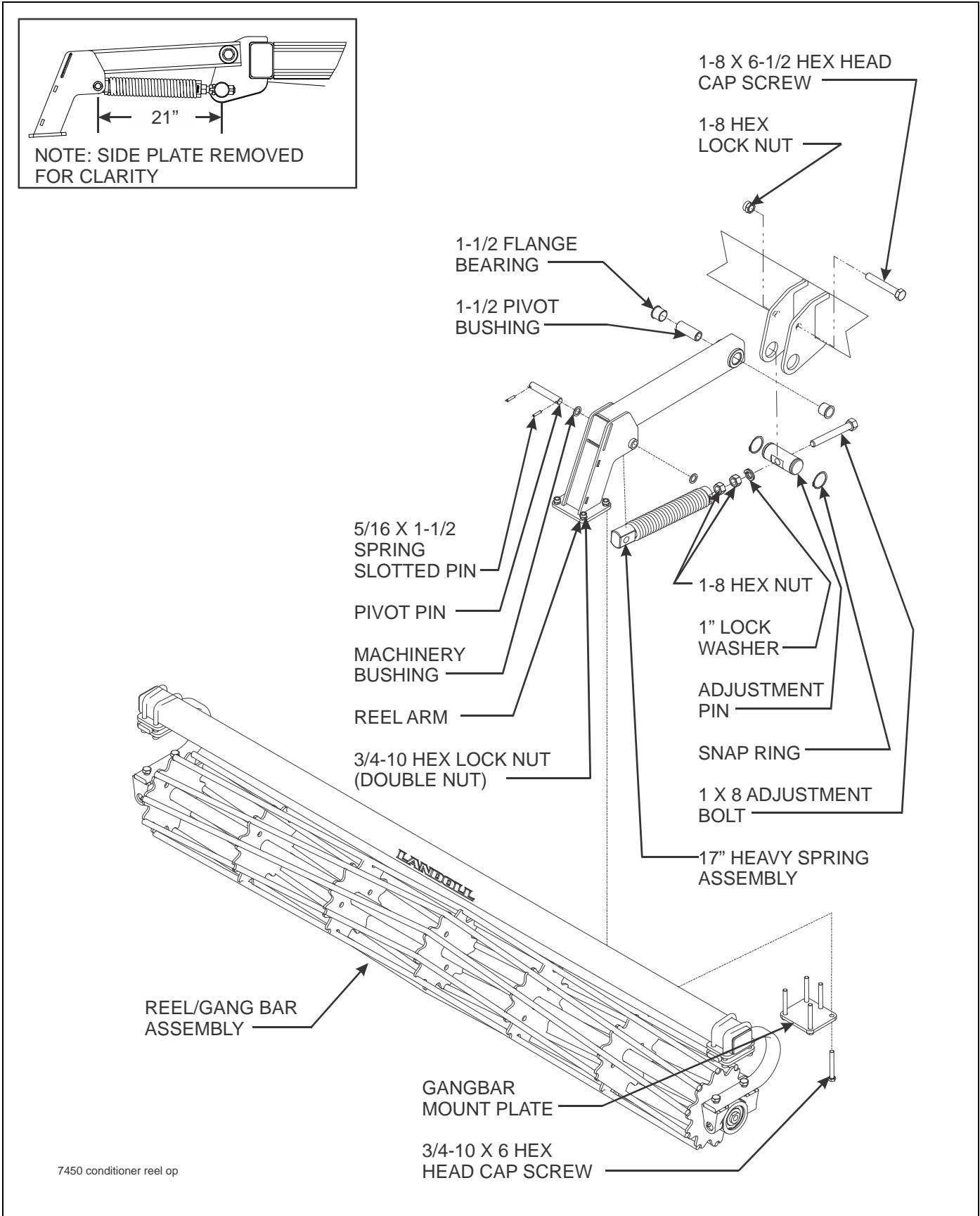

Figure 3-24: Conditioner Single Reel Installation

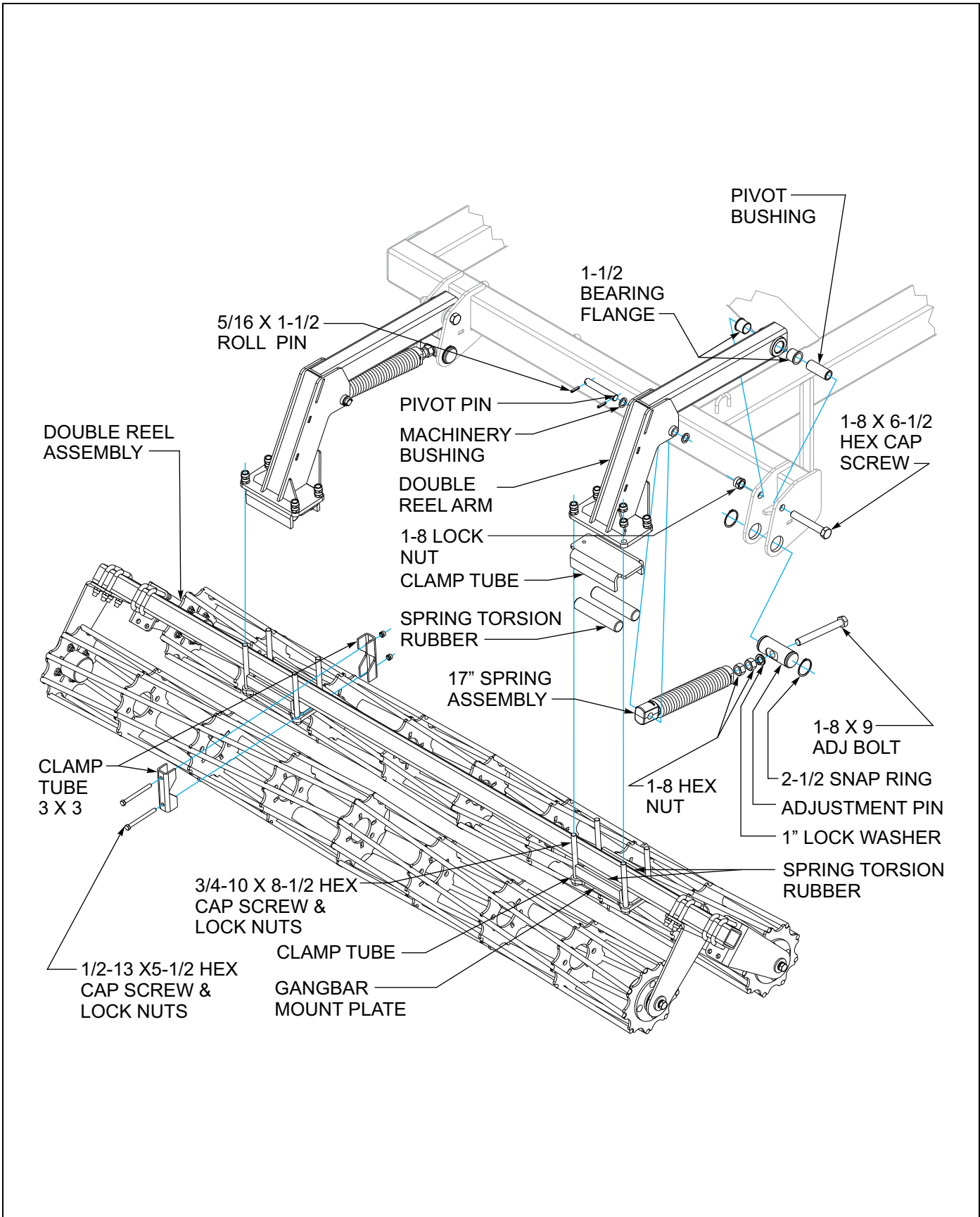

Figure 3-25: Conditioner Double Reel Installation

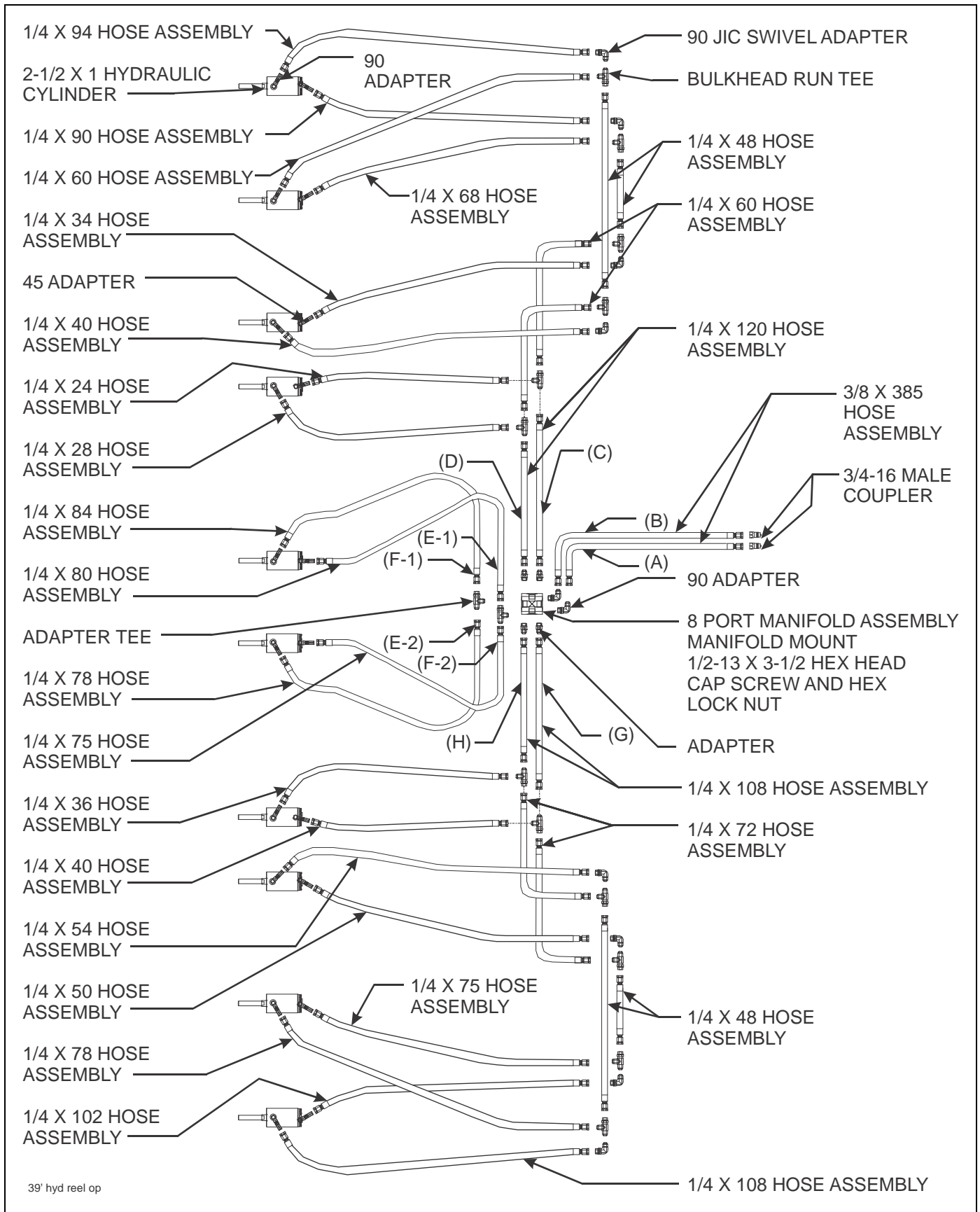

Figure 3-26: Finishing Reel Hydraulic Installation (39' Model)

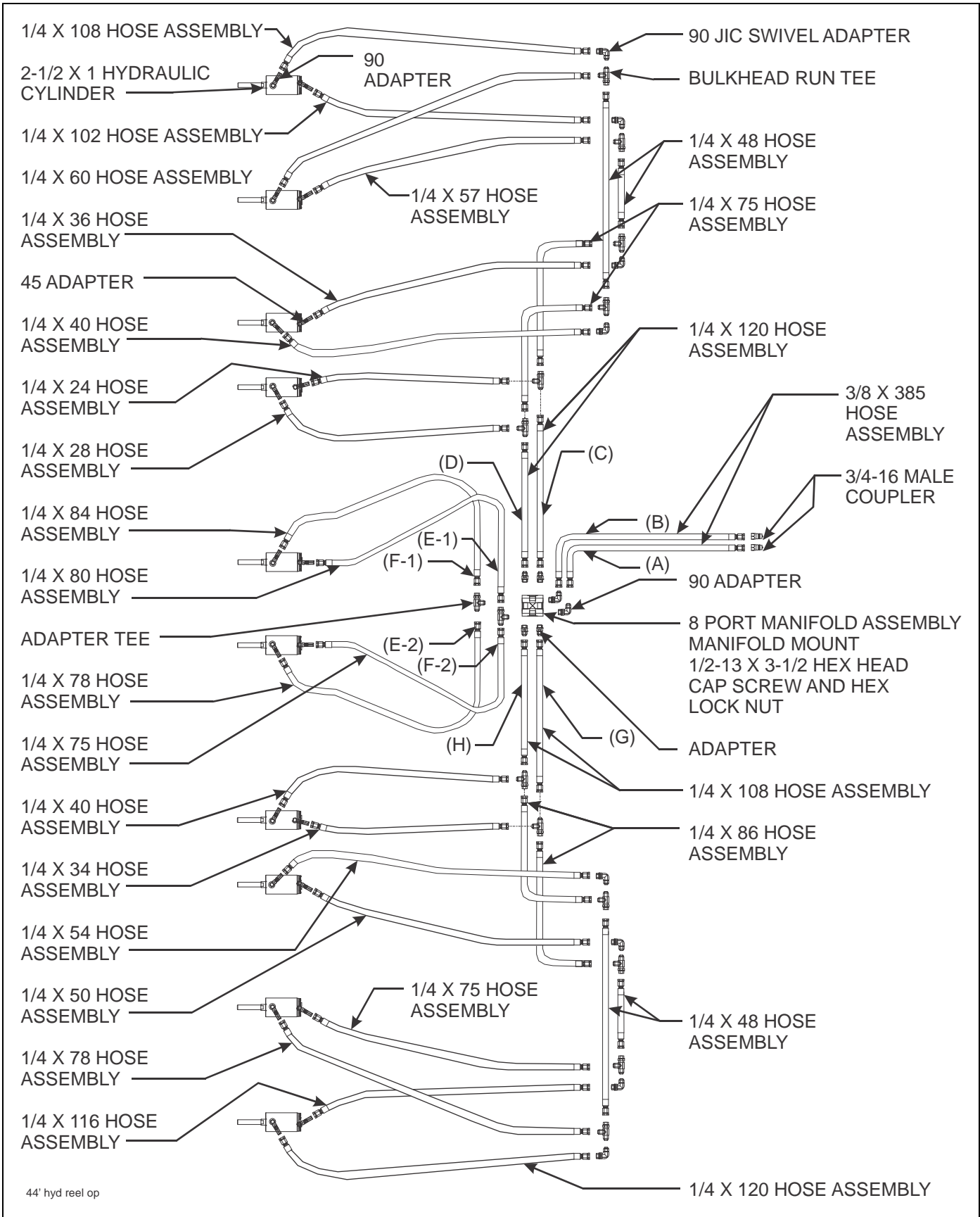

Figure 3-27: Finishing Reel Hydraulic Installation (44' Model)

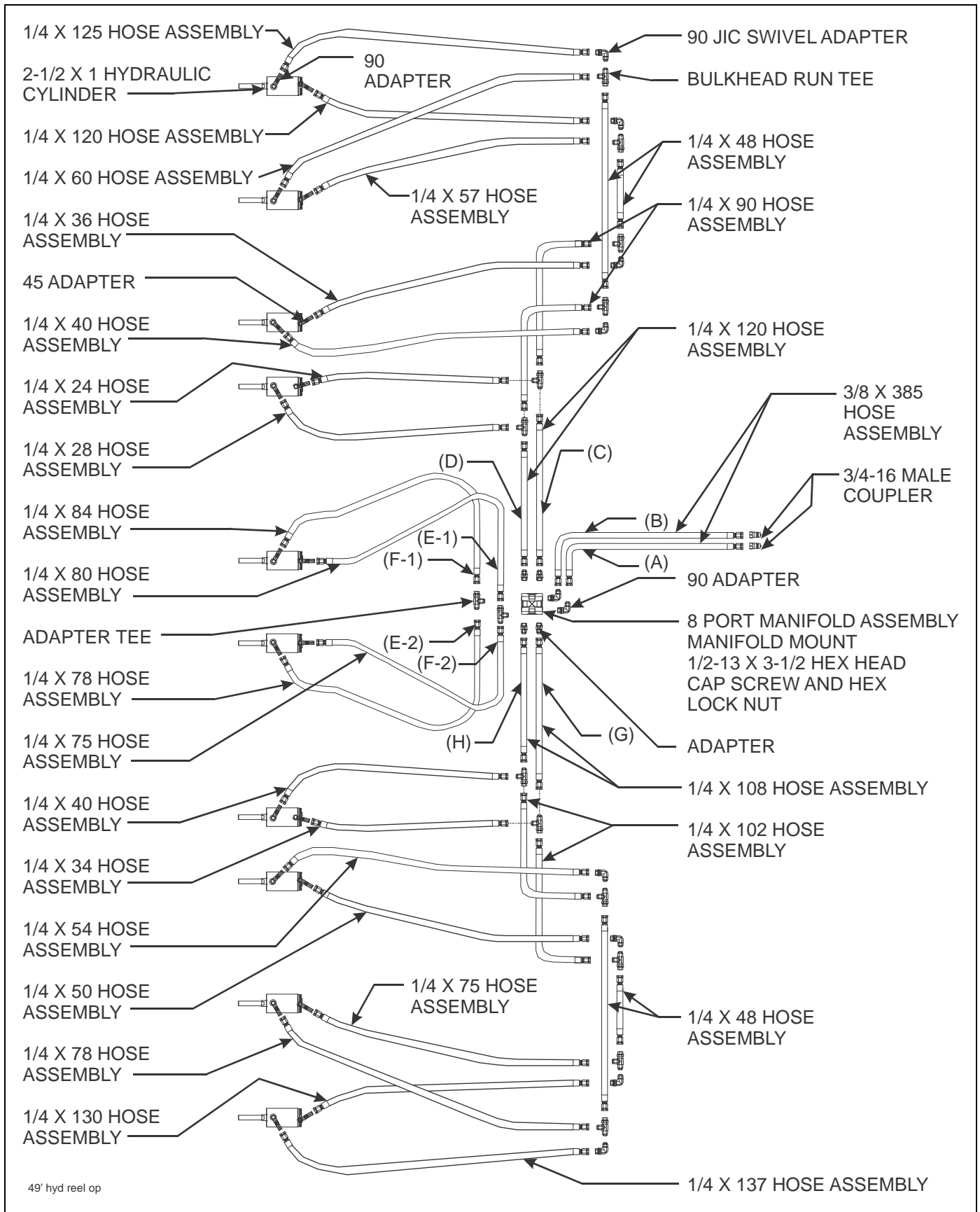

Figure 3-28: Finishing Reel Hydraulic Installation (49' Model)

Finishing Hydraulic Conditioner Reel Installation (Option)

NOTES

Refer to **Figure 3-26** for 7450-39' condition reel hydraulic diagram.

Refer to **Figure 3-27** for 7450-44' condition reel hydraulic diagram.

Refer to **Figure 3-28** for 7450-49' condition reel hydraulic diagram.

See **Figures 2-1 thru 2-12** for finishing conditioner reel placement dimensions.

NOTE

Center arm on center frame is a spring assembly and does not have a hydraulic cylinder attached to it.

1. Attach adjustment pin to center arm location on center frame with snap rings. Assemble 1 x 8 adjustment bolt through pin with 1" lock washer and (2) 1-8 hex nuts along with the 17" heavy spring assembly (**See Figure 3-31.**)
2. Attach 2-1/2" cylinders with the fitting on the barrel of the cylinder facing down to the other arm locations using cylinder trunnions. The center frame, inner wings, and the inside mounts of the outer wing will use the shorter cylinder trunnions, 1/2-13 x 1-1/2 hex head cap screw and split lock washer. The outer mounts of the outer wings will use the longer trunnion mounts, a reel arm stop, and a trunnion stop with 1/2-13 x 2-1/4 hex head cap screws and split lock washer (**See 3-32 and 3-29.**) and (**See 3-33**) for **double reel** See **Figures 2-1 thru 2-12** for reel arm stop locations.

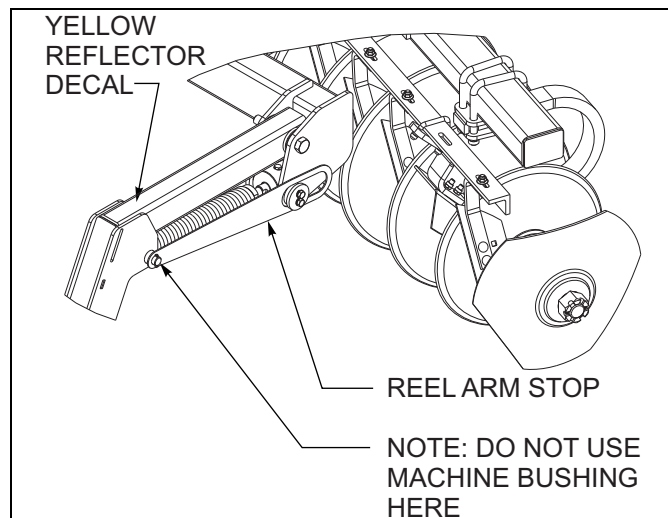

Figure 3-29: Conditioner Reel Arm Stop

3. Install 1-8 hex nut onto rod of cylinder and install 17" heavy spring assembly onto cylinder rod.
4. Install 1-1/2" flange bearing into reel arm, and slide in 1-1/2" pivot bushing.
5. Attach reel arm to upper hole using 1-8 x 6-1/2 hex head cap screw and hex lock nut.
6. Assemble 17" heavy spring assembly to reel arm using 1" pivot pin, 1" machinery bushings, and 5/16 x 1-1/2" spring slotted pins. Set pin centers to 21" dimension as shown in **Figure 3-31**. On the outer wings, the reel arm stop will replace the machinery bushings on the reel arm. The reel arm stop is to prevent the outer reels from hanging down so far while the machine is being folded.
7. Install manifold mount to rear of center frame with hose clamps just to the right of the center arm mount (**See Figure 3-30.**) Install the manifold to the mount using 1/2-13 x 3-1/2 hex head cap screws and hex lock nuts.

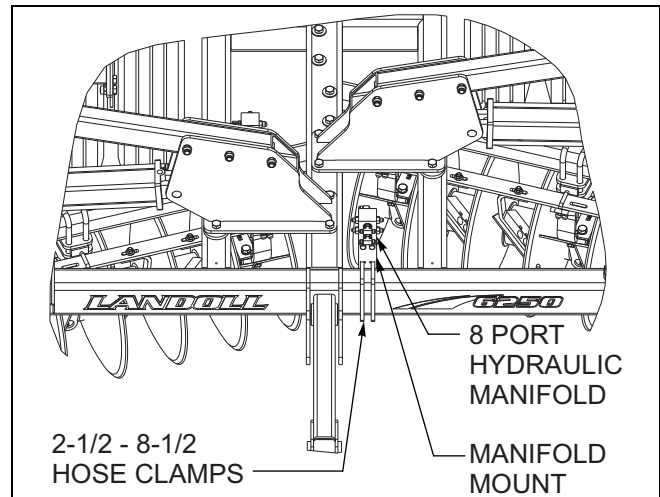

Figure 3-30: Mounting the Manifold Bracket

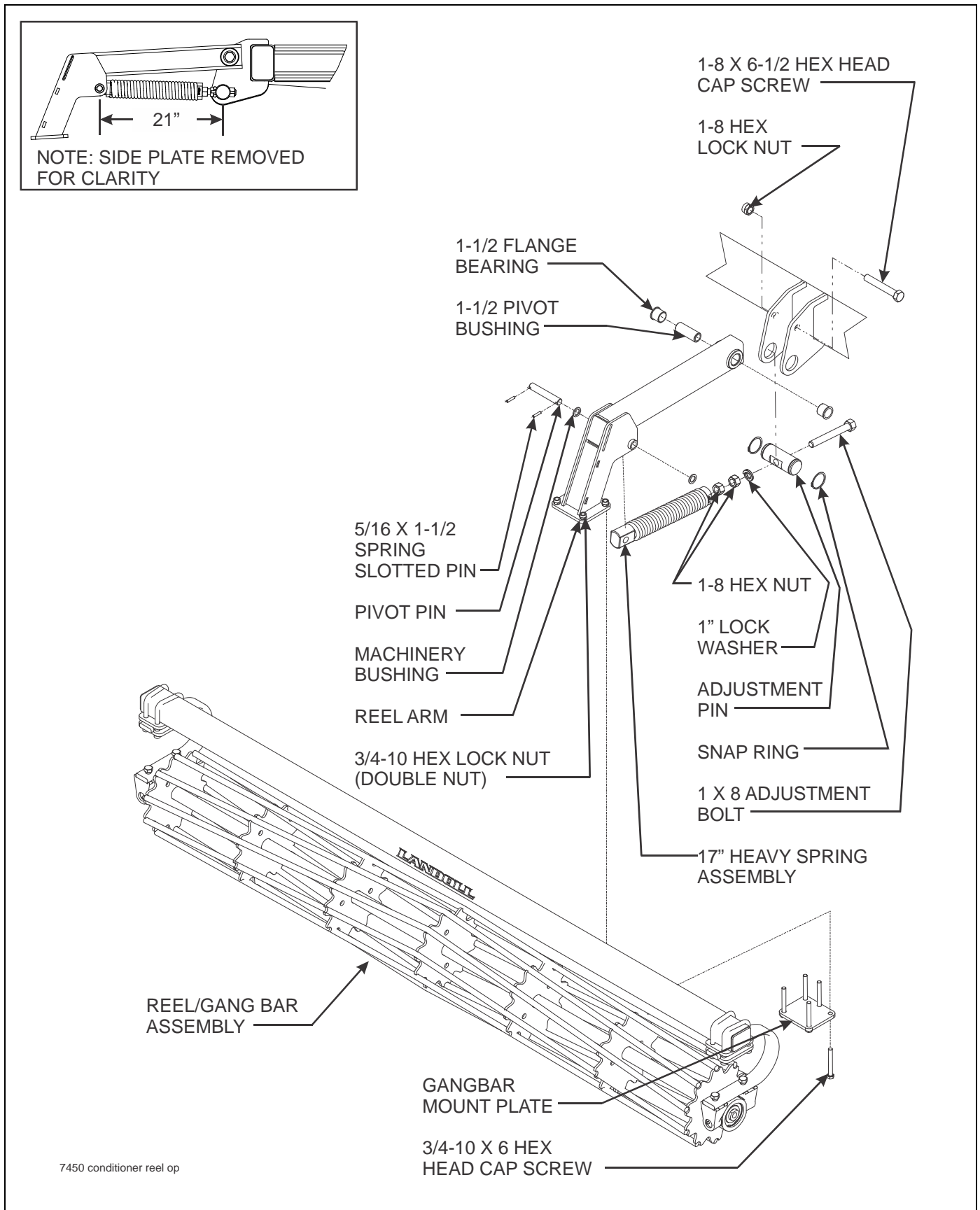

Figure 3-31: Finishing Conditioner Reel Installation (Center Arm for the Three Arm Reel) (Option)

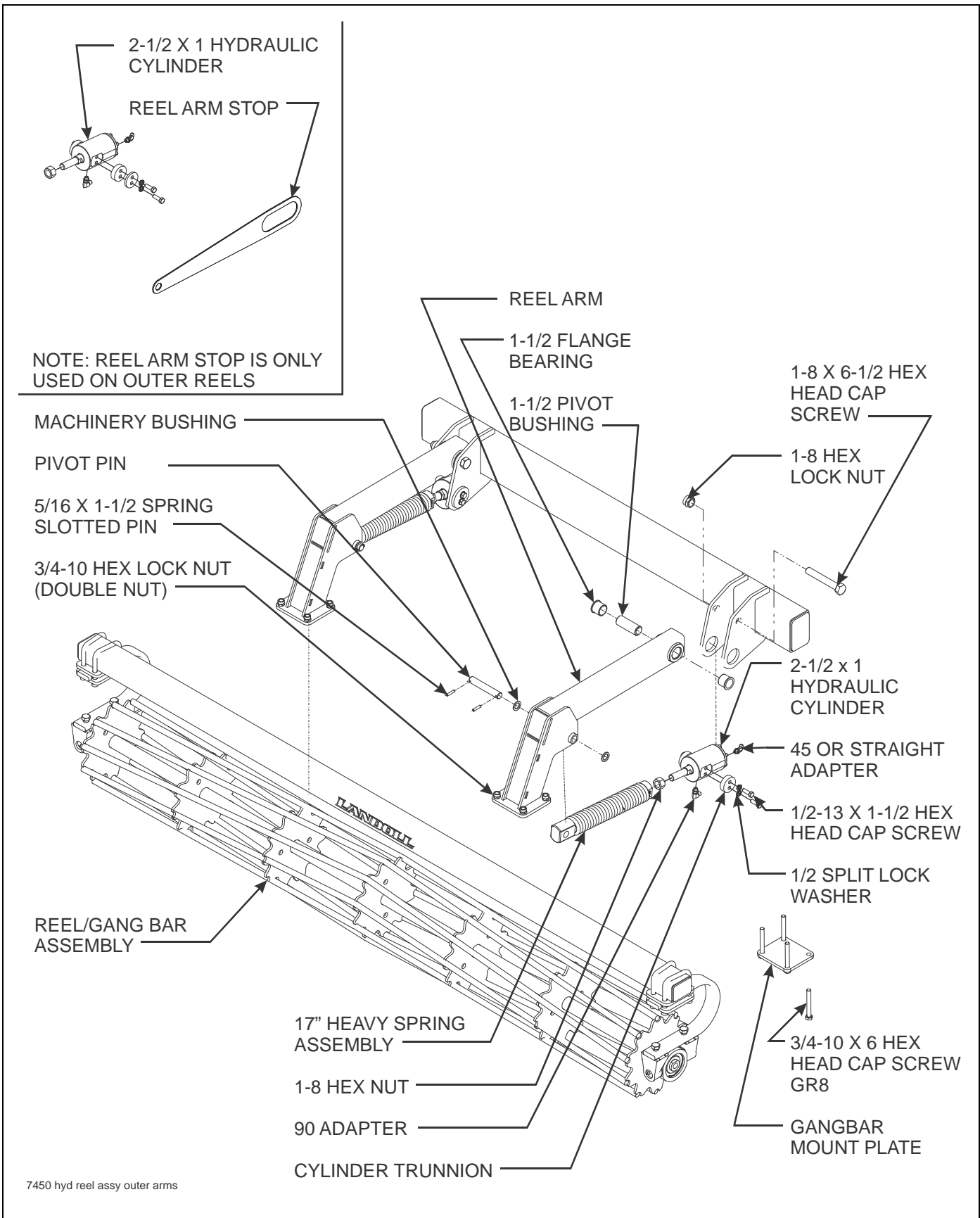

Figure 3-32: Finishing Conditioner Reel Installation (Outer Arms of Center Reel or Wing Reels) (Option)

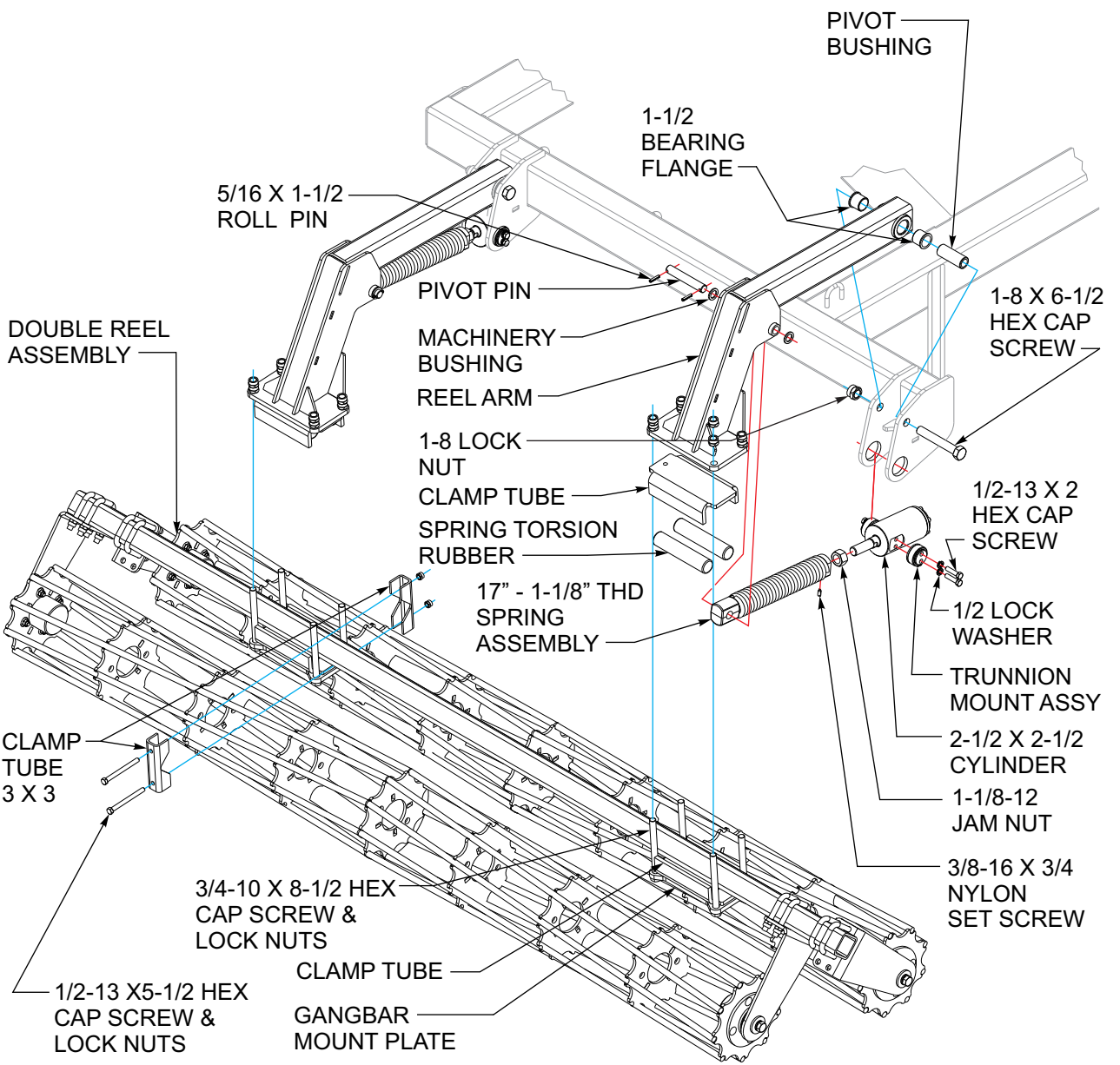

Figure 3-33: Finishing Conditioner Double Reel Installation (Option)

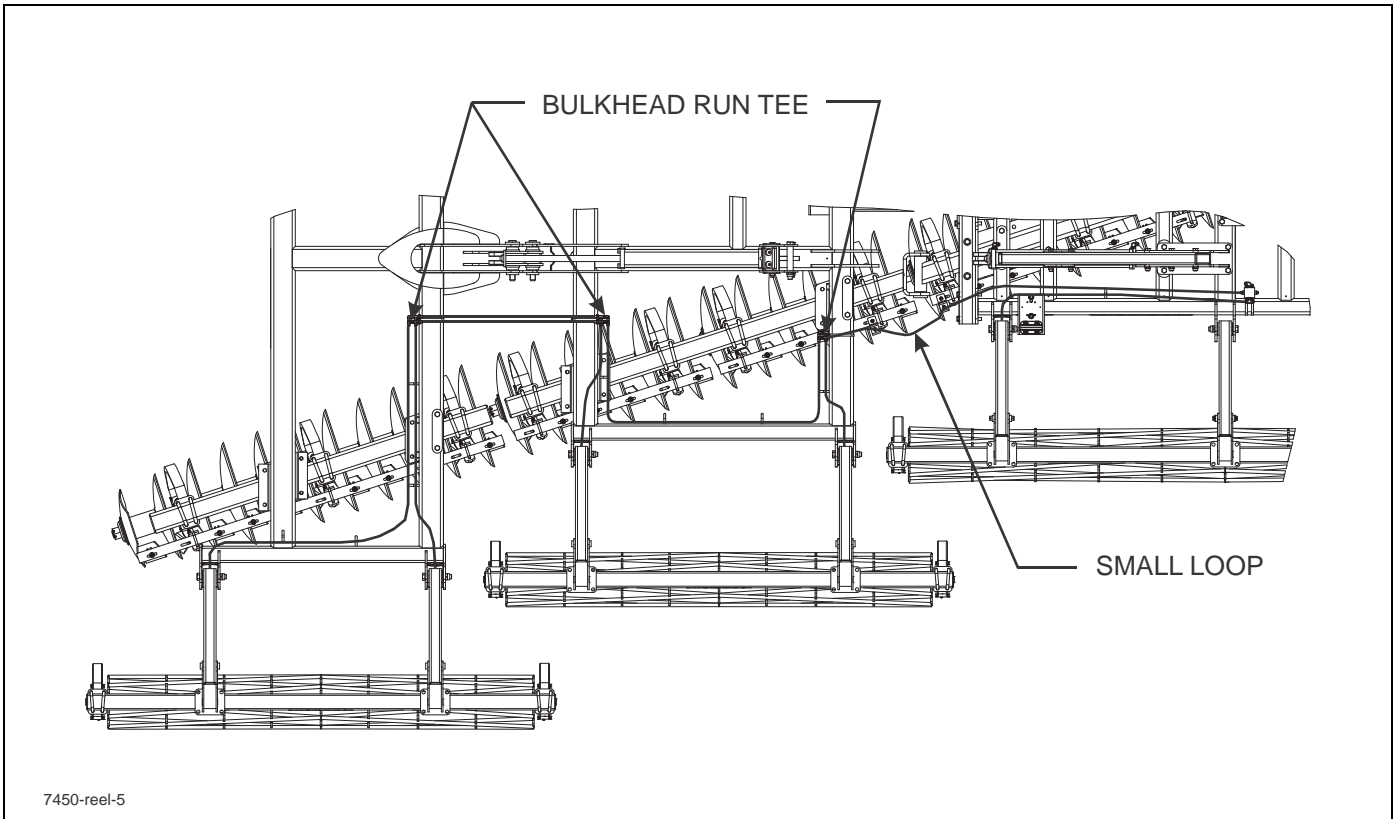

Figure 3-34: Finishing Conditioner Reel Installation Hydraulic Hose Placement (Left Half)

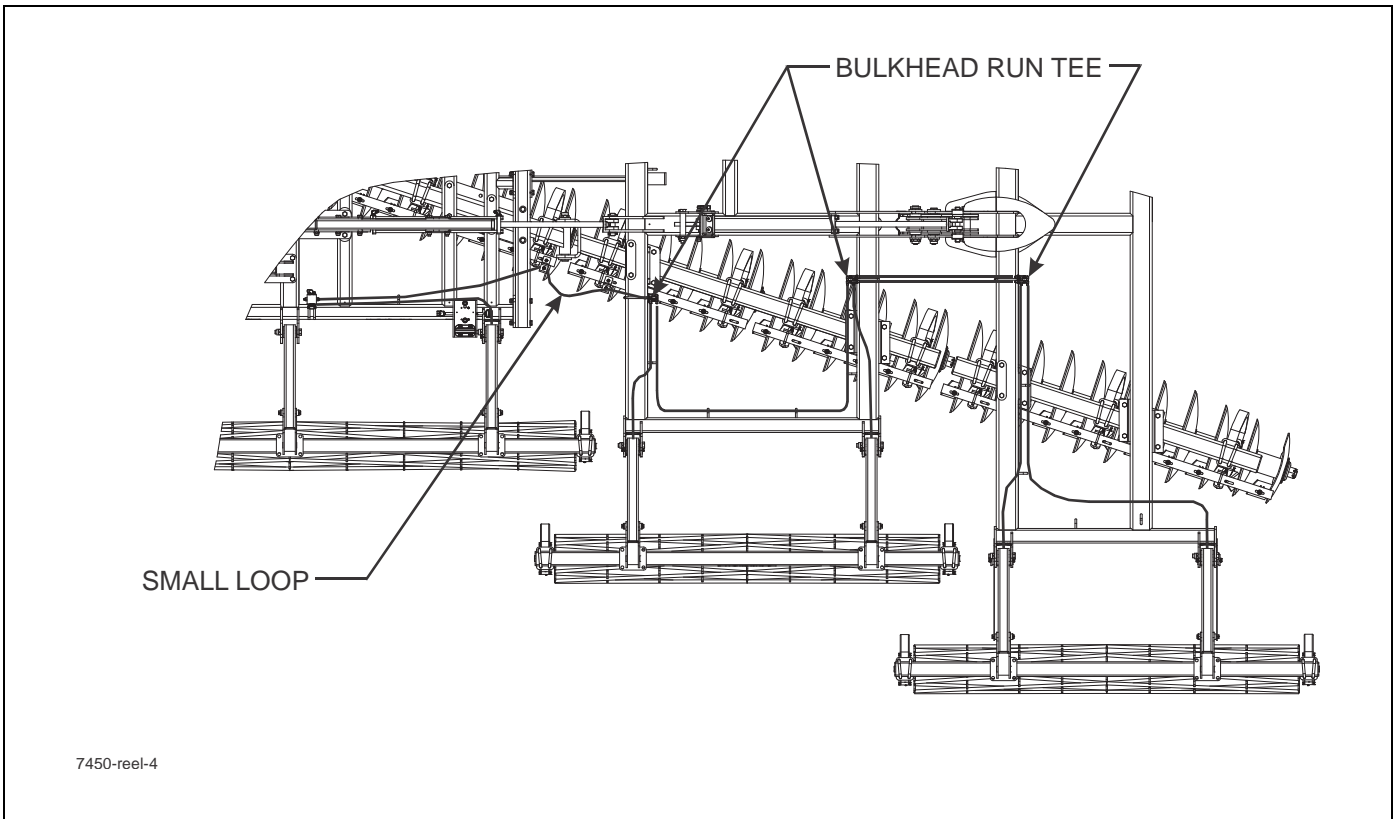

Figure 3-35: Finishing Conditioner Reel Installation Hydraulic Hose Placement (Right Half)

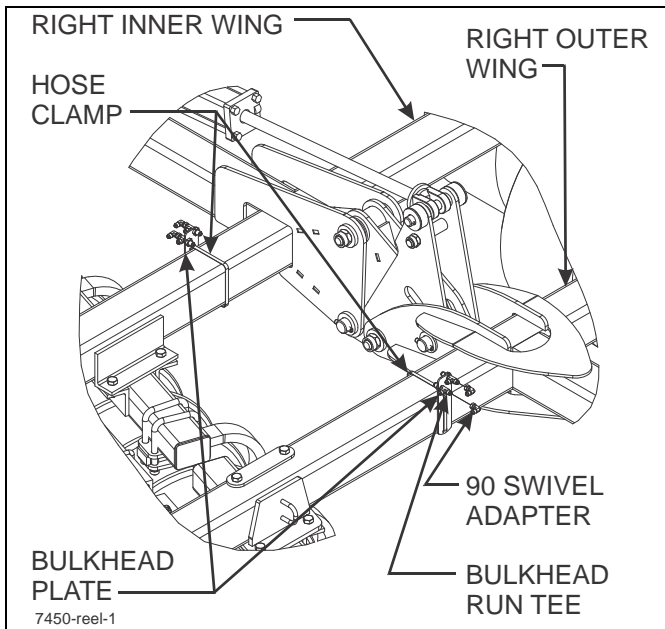

Figure 3-36: Mounting the Bulkhead Plates and Fittings to the Wings

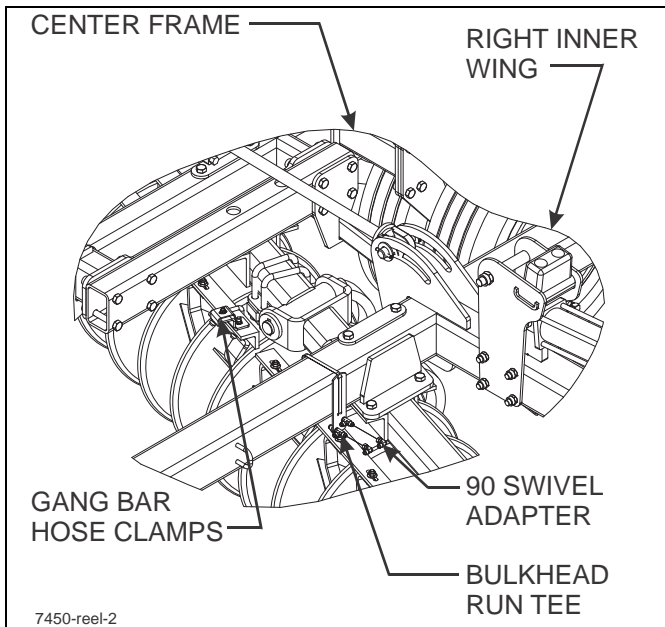

Figure 3-37: Mounting the Gang Bar Hose Clamps and Fittings

8. Install fittings into manifold according to **Figures 3-26 through 3-28**.
9. Install bulkhead plates to the inner and outer wings with hose clamps (**3-36 and 3-37**.) Assemble bulkhead tees and 90° swivel adapters onto each of them.
10. Install fittings into 2-1/2" cylinders. All cylinders will have a 90° fitting on the bottom side. The outer cylinders on each side have a 45° fitting in the base end and the others are a straight adapter.
11. Install hoses per **Figures 3-26 through 3-28**. Hose routing to follow **Figures 3-34 and 3-35**.
12. Install hose clamp brackets as shown at hinge lines with 1/2-13x1-1/2 round head square neck bolts and nuts. Assemble hose clamp with 3/8-16 x 1-1/2 bolts and 3/8 flange lock nuts (**See Figure 3-38**.)

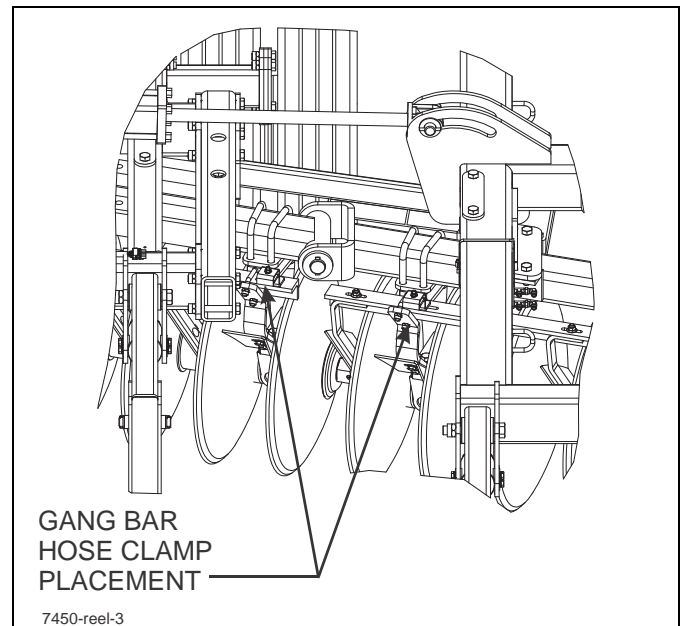

Figure 3-38: Gang Bar Hose Clamp Placement

13. Install other hose clamps as needed to secure hoses.

NOTE

The outer two reels will need enough slack in the hoses to go to the end of the stops when folded so allow some extra hose next to the cylinder.



WARNING

Do not attempt to lift heavy parts (such as the frame, disc gangs, lift, pull hitch, or reel/gang bar assembly manually. Use a hoist or a forklift to move these parts into position.

14. Attach reel/gang bar assembly to reel arms using gang bar mount plate, 3/4-10 x 6 hex head cap screws and double hex lock nuts. **Refer to Figures 2-1 thru 2-6** for reel gang bar placement locations.
15. Attach yellow reflector decals on outer arms (**See Figure 3-39.**) Decals are located in the manual tube. Reflector decal locations also shown in **Figures 2-1 thru 2-6.**

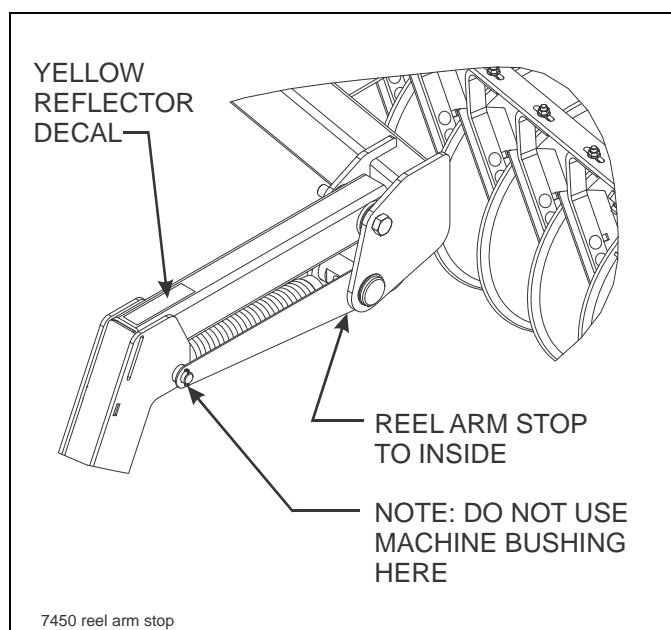

Figure 3-39: Yellow Reflector Decal Placement

Final Assembly

1. Attach a tractor to the implement and charge the lift system hydraulics as described in **“Hydraulic Lift System”** on page 4-3.
2. Connect the hydraulic hoses on the hydraulic leveler to the tractor. Fully extend and retract the hydraulic leveler several times to remove any air.
3. The fold system must be purged of air and filled with oil **BEFORE** attempting to fold the implement. Air in the system will allow the wings to fall uncontrollably and may result in implement damage. Follow instructions for charging the hydraulic fold system as described in **“Hydraulic Fold System”** on page 4-5.
4. Connect lights to the tractor and verify operation.
5. Check tires for proper inflation
6. Level the implement from side to side as described in **“Leveling (Side to Side)”** on page 4-8.
7. Inspect the final implement assembly, and verify that all bolts have been tightened, cotter pins spread, and that there are no leaking hydraulic connections.
8. Rotate each disc gang to verify that each gang rotates freely. Adjust any scrapers that may have shifted during shipment or assembly.
9. Lubricate the implement at all locations (**See “Lubrication Maintenance”** on page 4-21.)
10. Touch up with paint any areas that may have been scratched during moving, handling, or assembly.
11. Thoroughly read and understand the operating section before using the implement.

Operation and Maintenance



DANGER

Never allow anyone to ride on the 7450 VT Plus at any time. Allowing a person to ride on the machine can inflict serious personal injury or death to that person.



DANGER

Disc blades are extremely sharp. Exercise extreme care when working on or near disc blades. Do not allow discs to roll over or fall onto any bodily part. Do not allow wrenches to slip when working near disc blades. Never push wrenches toward disc blades. Do not climb over machine above disc blades. Failure to stay clear of disc blade edges can cause serious personal injury or death.



WARNING

All hydraulically elevated equipment must have cylinder lockouts installed or be lowered to the ground, when servicing or when equipment is idle. Failure to take preventive measures against accidental lowering can result in serious personal injury.



DANGER

Always lock the tractor drawbar in the center position when transporting the unit. Failure to do so can result in serious injury or death and cause damage to the equipment.



DANGER

When transporting the unit, place cylinder lockouts in the transport lock position after fully extending the cylinders. Insert the lockout pins to secure the cylinder lockouts. Failure to lockout the cylinders can cause the unit to settle during transport, which can result in serious injury or death and cause damage to the equipment.



CAUTION

When transporting farm implements on public roads, it is the responsibility of the operator to abide by state and local laws concerning wide loads, speed, safety emblems and safety lighting equipment. Drive at safe speeds. Particularly when rounding corners, crossing rough ground or driving on hillsides, to prevent tipping the tractor.

Tractor Preparation

The Landoll 7450 VT Plus is designed to be pulled by tractor equipped with a double lip or clevis type hitch CAT IV or V. If your tractor is not equipped as such, you need to purchase the hitch from your local tractor dealer.

Before attaching the VT Plus, prepare the tractor as follows:

1. Inflate the rear tractor tires equally and add ballast according to the tractor operator's manual.
2. Lock the tractor drawbar in the center position.

VT Plus Preparation

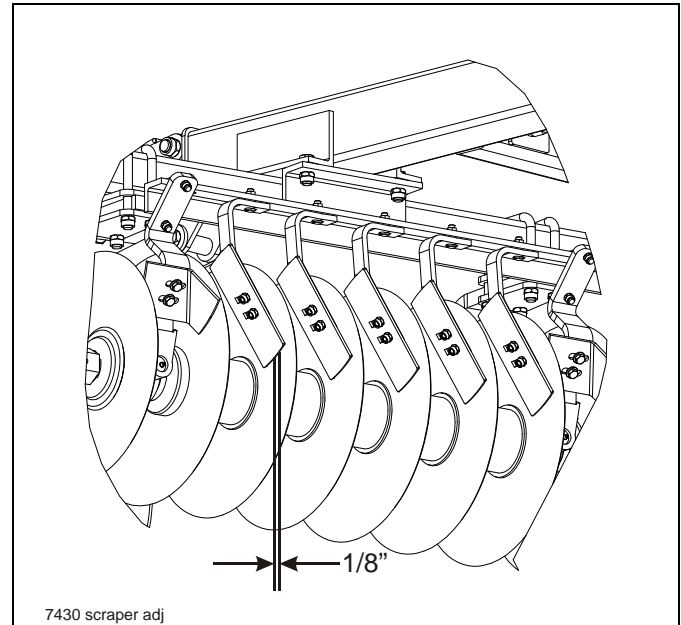

Figure 4-1: Disc Scraper to Disc Blade

1. Prior to operating the 7450 VT Plus, inspect it thoroughly for good operating condition.
2. Replace worn or missing parts.
3. When the machine is new, check the bolt tightness after a few hours of operation. Tighten any loose nuts or bolts. Check the lift wheel lug bolts daily.
4. Check the lift wheel tire inflation. Inflate all tires equally to avoid side draft. Follow the tire manufacturer's recommended pressures listed on the sidewall of the tires.
5. Check disc scrapers for proper adjustment to the disc blade **(See Figure 4-1.)**
6. Lubricate the machine as shown in **"Lubrication Maintenance"** on page 4-21 **(See Figure 4-23.)**

Attaching to the Tractor

1. Align the tractor drawbar with the machine. Raise or lower the disc ring hitch, as needed, using the swivel jack. Attach the unit with proper size hitch pin.
2. Always place the swivel jack on the interior mount before setting the machine in motion.
3. Clean all hydraulic couplings and attach to the tractor.

Hydraulic Lift System

The VT Plus is equipped with a rephasing hydraulic lift system to raise and lower the unit in the field.

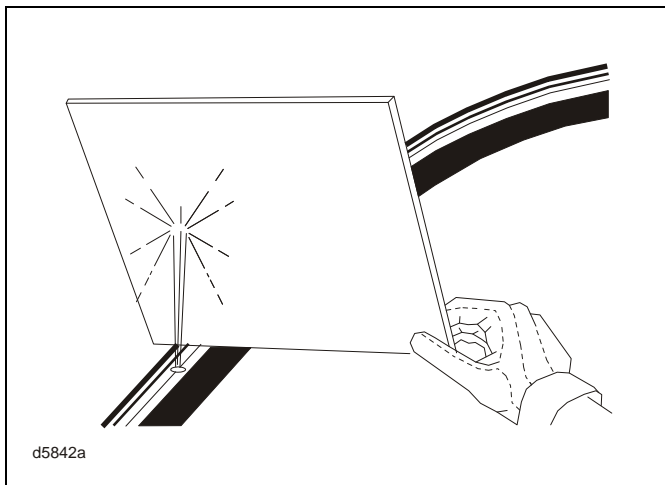

Figure 4-2: Hydraulic Leak Detection



WARNING

Escaping hydraulic fluid can cause serious personnel injury. Relieve system pressure before repairing, adjusting, or disconnecting. Wear proper hand and eye protection when searching for leaks. Use cardboard instead of hands (See Figure 4-2.) Keep all components (cylinders, hoses, fittings, etc.) in good repair.

1. The rephasing hydraulic lift system contains smaller wing frame cylinders plumbed in series with larger center frame cylinders. It is important that the cylinders be connected in the proper series for the lift system to operate correctly. When the cylinders are fully extended and held in this position, oil is able to flow through the cylinders (or rephase) and allow the cylinders to operate in sync. This also allows the system to purge any air that may enter the system without having to loosen or crack hydraulic lines.

- The hydraulic system is not filled with oil and should be purged of air before transporting and field operations. Carefully hitch the VT Plus to the tractor and connect the hydraulic lift hoses. Check to make sure the tractor hydraulic reservoir is full of the manufacturer's recommended oil. Slowly raise the machine, and continue to hold the hydraulic lever until all lift cylinders are fully extended. Lower and raise the unit to verify that all cylinders are working simultaneously throughout the stroke. If the cylinders are not working evenly or together, fully extend the lift cylinders and continue to hold the lever to purge any remaining air. Do not loosen any hoses or fittings. Recheck tractor reservoir to make sure it is within operating limits.
- Always fully extend the cylinders and hold the lever to ensure the cylinders are rephased before starting any field operation. This will keep all cylinders in time and frame sections level when operating.
- The transport locks for the hydraulic lift system are plumbed into the fold system. During folding they are activated to lock the machine up in the fully raised position, while unfolding the locks are released permitting the machine to be lowered.

NOTE

If performing service or repair work, activate the fold to engage the transport locks, or lower the machine down to the ground and relieve hydraulic pressure.

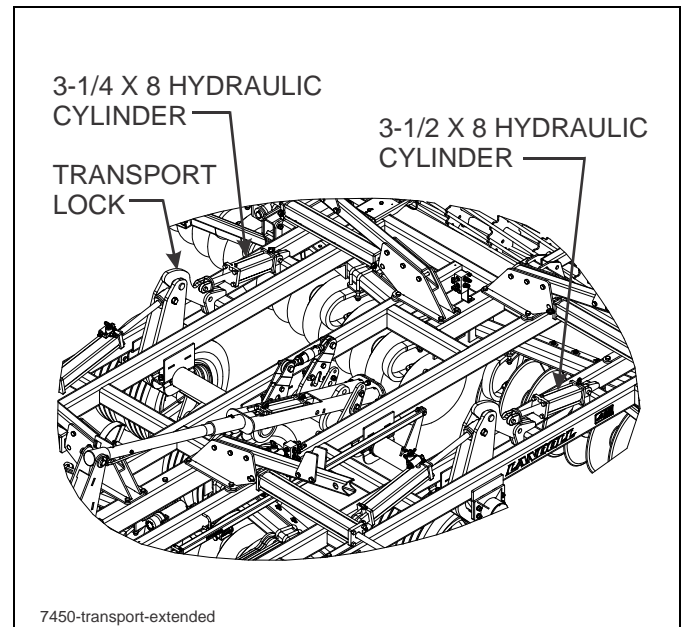

Figure 4-3: Installed Transport Locks

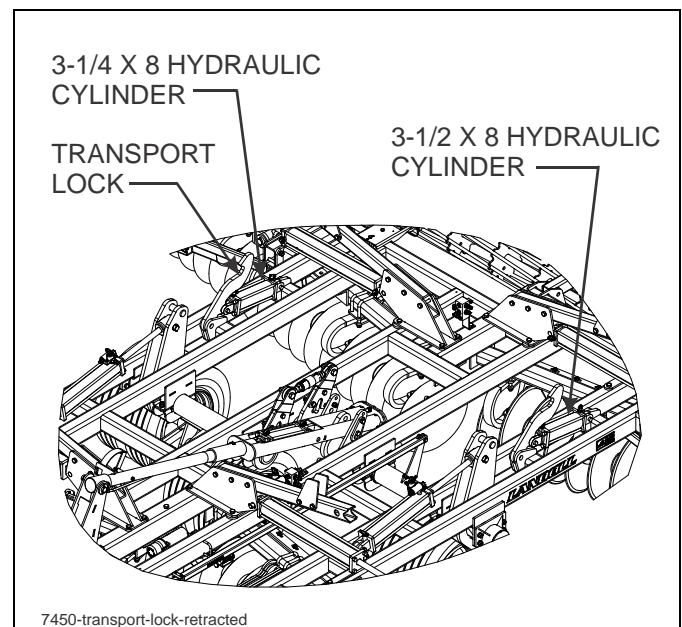

Figure 4-4: Stored Transport Locks

Hydraulic Fold System

1. The VT Plus is equipped with a hydraulic fold system to raise and lower the wing frames for narrow transport.
2. Be sure the system is fully charged with hydraulic oil before attempting to fold/unfold the unit. Air in the system can allow uncontrolled dropping of the wing frames causing serious personal injury or machine damage. The system needs to be charged with oil initially and any time the system has been opened for repair such as cylinder, hose, or fitting replacement/repair.

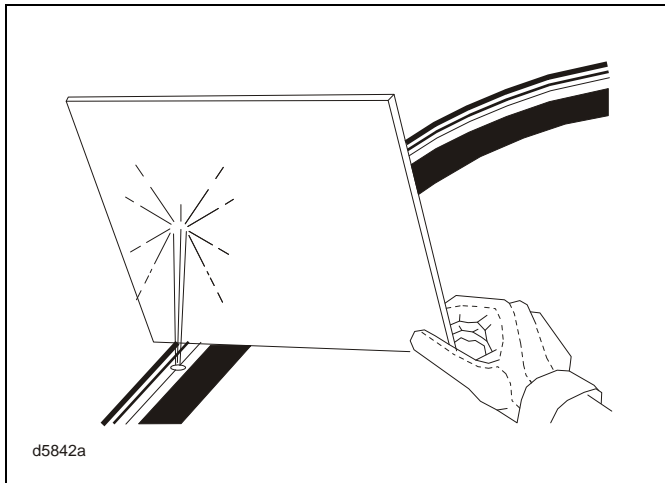

Figure 4-5: Hydraulic Leak Detection

3. To charge the system, carefully hitch the VT Plus to the tractor. **Unpin the end(s) of the fold cylinders, and position them so they can extend and retract without contacting any frames or other parts.** Check the tractor hydraulic fluid level to make sure it is full of the manufacturer's recommended hydraulic fluid. Connect the cylinder hoses to the tractor and fully extend and retract the cylinders several times. The cylinder rod travel should be smooth and positive when all air has been purged from the system. Due to large amounts of hydraulic oil required, recheck the tractor fluid level to make sure it is within proper operating limits.
4. The hydraulic fold system is equipped with restrictors in the rod end of cylinders to prevent uncontrolled falling of wing frames when unfolding. Removal or improper assembly of these restrictors can cause the machine to fold improperly and result in serious machine damage.



WARNING

Escaping hydraulic fluid can cause serious personal injury. Relieve system pressure before repairing, adjusting, or disconnecting. Wear proper hand and eye protection when searching for leaks. Use cardboard instead of hands (See Figure 4-5.) Keep all components (cylinders, hoses, fittings, etc.) in good repair.

5. To fold/unfold the VT Plus, find a level area large enough to accommodate the VT Plus when it is fully unfolded. The tractor should be stopped and not moving with the unit fully raised. **See "Folding the 7450 VT Plus" on page 4-6 and "Unfolding the 7450 VT Plus" on page 4-6** for further instructions on folding and unfolding the VT Plus.

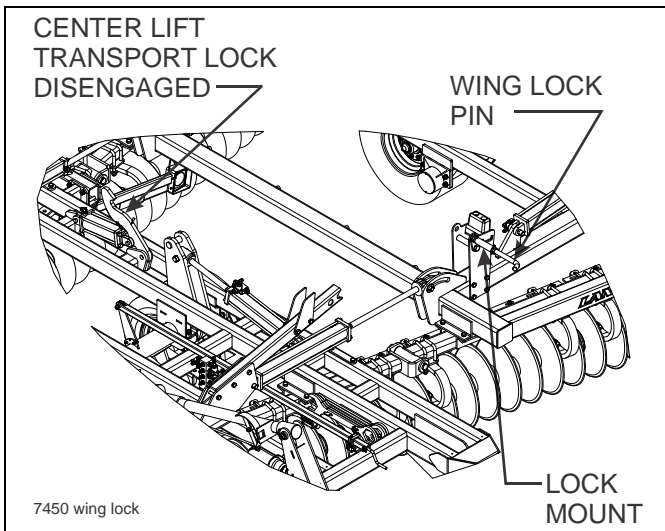

Figure 4-6: Stored Transport Locks

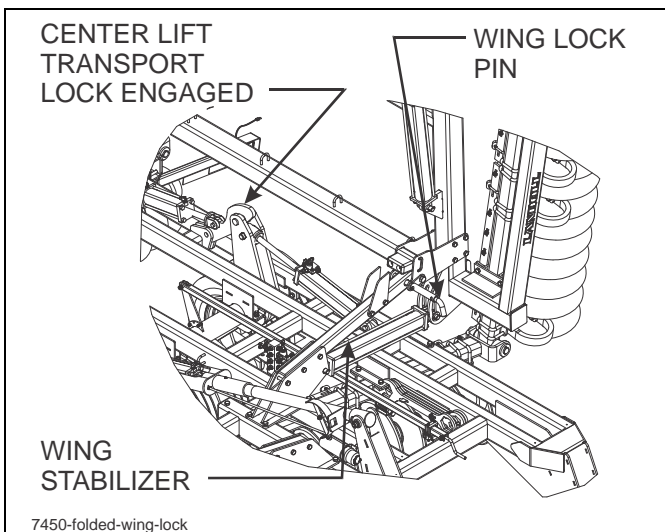

Figure 4-7: Installed Transport Locks

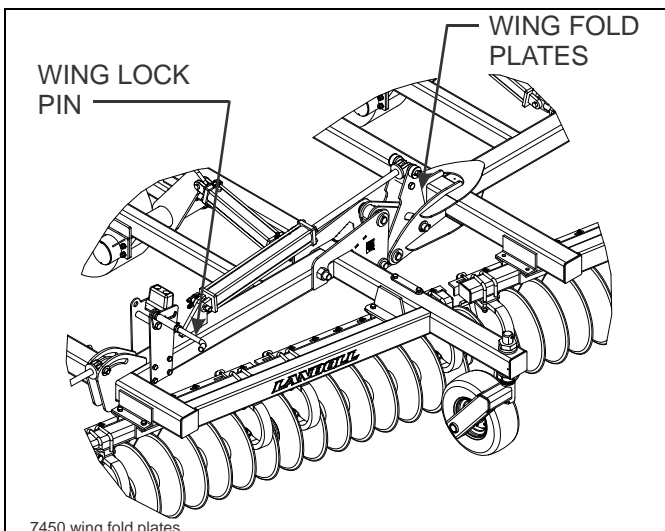

Figure 4-8: Wing Fold Plates

Folding the 7450 VT Plus

1. Fully raise machine.
2. Begin folding the machine. Transport locks will engage on the center lift as the outer wings are folding, fully fold all inner and outer wings (See Figures 4-6 and 4-7).
3. Take note that both center lift transport locks are engaged. Lower machine to locks and continue to hold lever, this will allow the inner and outer wing transport wheels to retract, reducing the transport width.
4. When the unit is fully folded, rotate and slide wing lock pins rearward to engage wing lift transport locks (See Figure 4-7.)

Unfolding the 7450 VT Plus

1. Disengage wing transport locks.

IMPORTANT

Failure to remove the lock pins when unfolding will result in serious damage to the implement. Be sure other people and pets are a safe distance away.

2. Fully raise the folded machine to unhook the locks and continue to hold the lever to fully extend the wing transport wheels (See Figures 4-6 and 4-7).
3. Unfold the machine. Transport locks will disengage from the center lifts during the unfolding process.
4. Continue to hold lever until the fold cylinders are fully extended to lock the outer wing fold plates (See Figure 4-8.) This will allow the wings to fully flex in the field.

NOTE

If the operator chooses to leave the wing transport wheels extended while transporting the VT Plus, some settling of the machine may occur and it may be necessary to raise the machine to disengage the center lift transport locks.

General Operation

1. The horsepower requirements are typically 8-10 horsepower per foot of cut. This will vary widely due to speed, depth, moisture, residue and types of soils. Local dealers can help in making recommendations for your areas.
2. Operating speed is typically 6 - 9 mph. Excessive speed can cause the unit to bounce, uneven depth, and create a ridge on the outside edges. Too low of speed may not allow the unit to properly fill in the center furrow.
3. Lift wheels must always be in contact with the ground and carrying some implement weight. Lift wheels are used to gauge the depth of each frame section and to control the leveling feature. Maximum discing depth cannot be achieved by raising the lift wheels off the ground. Little or no weight on the lift wheels will cause the frame sections to gouge, side-draft, and buckle producing inconsistent cutting depth.
4. Do not turn with the VT Plus in the ground, this can put excessive side load on the gangs and hitch. Raise the unit slightly when making turns to prevent gouging and pushing a ridge.

Field Operation

1. Raise the unit to take the weight off of the transport locks.
2. Remove the wing lock pins by sliding forward. Unfold the wings and extend the fold cylinders completely noting that the transport locks are also disengaged (See Figure 4-6.)



CAUTION

Failure to remove wing lock pins before unfolding wings will cause permanent equipment damage.

Leveling (Side to Side)

1. An adjustable radius rod connects the center frame lifts together to keep them operating in unison. The radius rod does not level the center frame lift. The radius rod length is determined initially by fully retracting the lift cylinders and adjusting the radius rod until it is loose and tightening the jam nuts.

2. To level the center frame:
 - a. Verify that all of the tires are properly inflated.
 - b. With the unit unfolded, raise it to fully extend the lift cylinders and continue holding the tractor lever 30-60 seconds to insure the cylinders are fully extended and the rephrasing lift system has been purged of air.
 - c. Lower the unit so the disc blades are 1" off the ground.
 - d. Measure the distance from the walking beam spindle to the top of the frame on both sides. If there is a difference, it needs to be adjusted by turning the cylinder rods with the wrench flats provided at the clevis end (**See Figure 4-9.**)
 - e. Let the machine down onto the ground to relieve any pressure, but do not fully retract the cylinders.
 - f. Loosen the set screw in the cylinder rod block. If the difference is 1/4" this requires turning the rod of the short side one full revolution to lengthen the cylinder. If the difference is 1/2" this requires turning the rod of the short side out one full turn and the rod of the tall side in one full revolution. Any differences of less than a 1/4" are acceptable for operating.

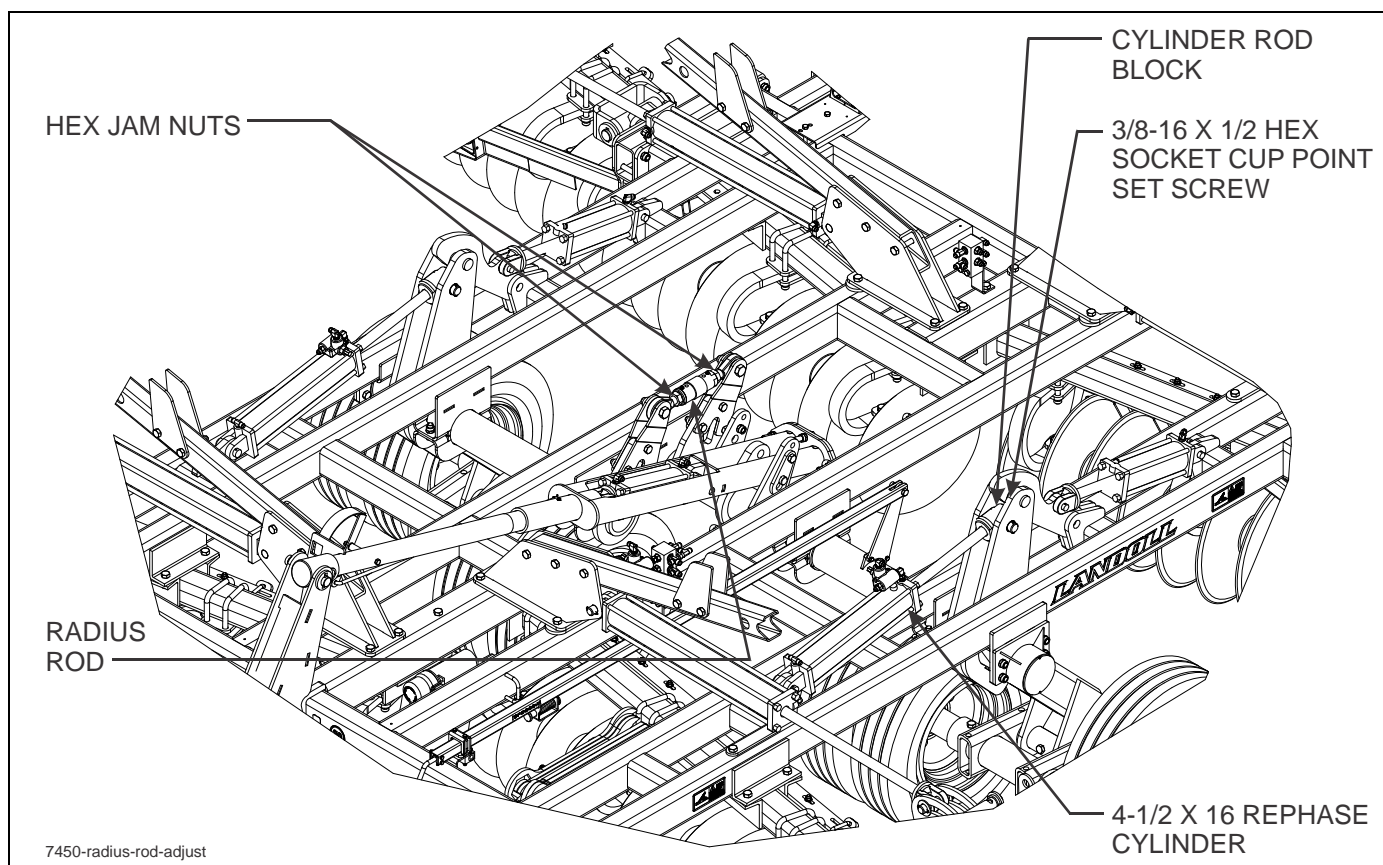

Figure 4-9: Leveling the Center Frame

3. After adjusting the cylinder rod or rods, the radius rod needs to be adjusted back to a neutral position. This is accomplished by fully retracting the lift cylinders and adjusting the radius rod until there is no load on it, and then tightening the jam nuts on each end.

NOTE

Center frame cylinders may have 1/8" rod exposed when fully retracted due to the rephasing system.

4. Leveling the VT Plus side-to-side involves leveling the wing frame to the center frame. The unit should be level side-to-side when operating in the field.

5. To level the unit:
 - a. Verify that all tires are properly inflated, and that the center radius rod adjustment has been properly set.
 - b. With the implement unfolded, raise the unit to fully extend the lift cylinders. Continue to hold the tractor lever 30-60 seconds to insure that the cylinders are fully extended and the rephasing lift system has been purged of air.
 - c. Lower the unit until the disc blades are approximately 1" off the ground.
 - d. On the center frame, measure the distance from the welded tube in the walking beam to the top side of the frame (See Figure 4-10.)
 - e. On the wing frame, measure the distance from the welded washer to the top side of the wing frame (See Figure 4-11.)
 - f. Measure the same distance on the wing frame. The wing frames are generally set to the same distance or slightly higher than the center frame. The 7450 requires subtracting 1" from the center frame measurement for the wings due to the smaller tires on the center frame.
 - g. Adjusting the anchor at the base end of each wing lift cylinder sets wing frame height (See Figure 4-12.)

6. An adjusting wrench is provided to make this adjustment. It may be necessary to lower the wing to the ground and relieve weight on the cylinder anchor to make this adjustment. If required, fully raise the implement, lower to just above the ground, and re-verify measurements. Repeat as necessary and securely tighten the cylinder anchor when complete.

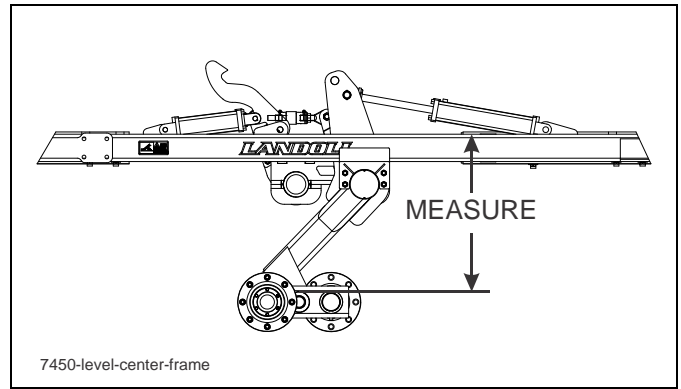

Figure 4-10: Leveling Center Frame from Side to Side

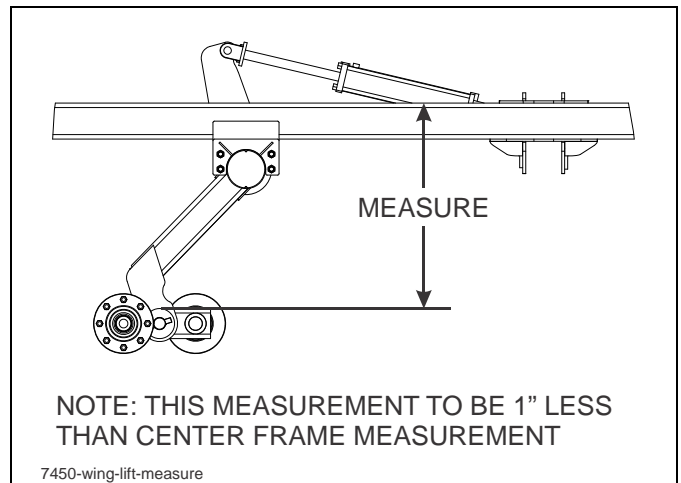

Figure 4-11: Leveling Wing from Side to Side

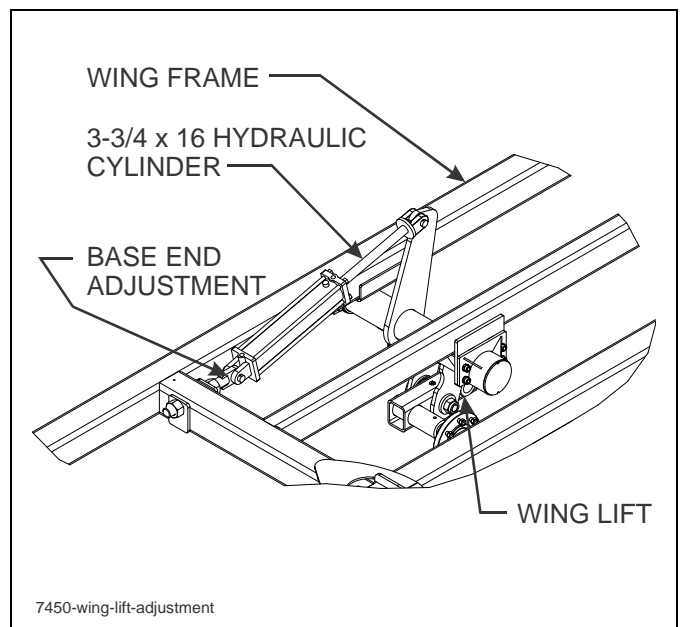

Figure 4-12: Wing Lift Adjustment

Leveling (Front-to-Rear)

1. The leveling feature on the VT Plus is used to keep the machine level when raising the unit from a working position to a transport position. The leveling feature is also used to level the unit from front-to-rear to perform a level discing operation in the field.
2. The unit should be level from front to rear and the soil behind the disc should be level without furrows or ridges. If there is a presence of a center ridge from the rear gangs, the rear gangs are too deep. If there is a furrow left from the rear gangs the front gangs are too deep.

3. Implements with the hydraulic leveler, can make adjustments on-the-go from the tractor. A reference gauge is provided on the implement for a guide.
4. For normal operation the leveler will be set in the bottom hole on the lift and the outer hole on the leveler tube (See Figure 4-13.)

IMPORTANT

Improperly set gauge wheels can prevent the leveler from functioning properly. Large adjustments will require adjustment of gauge wheels.

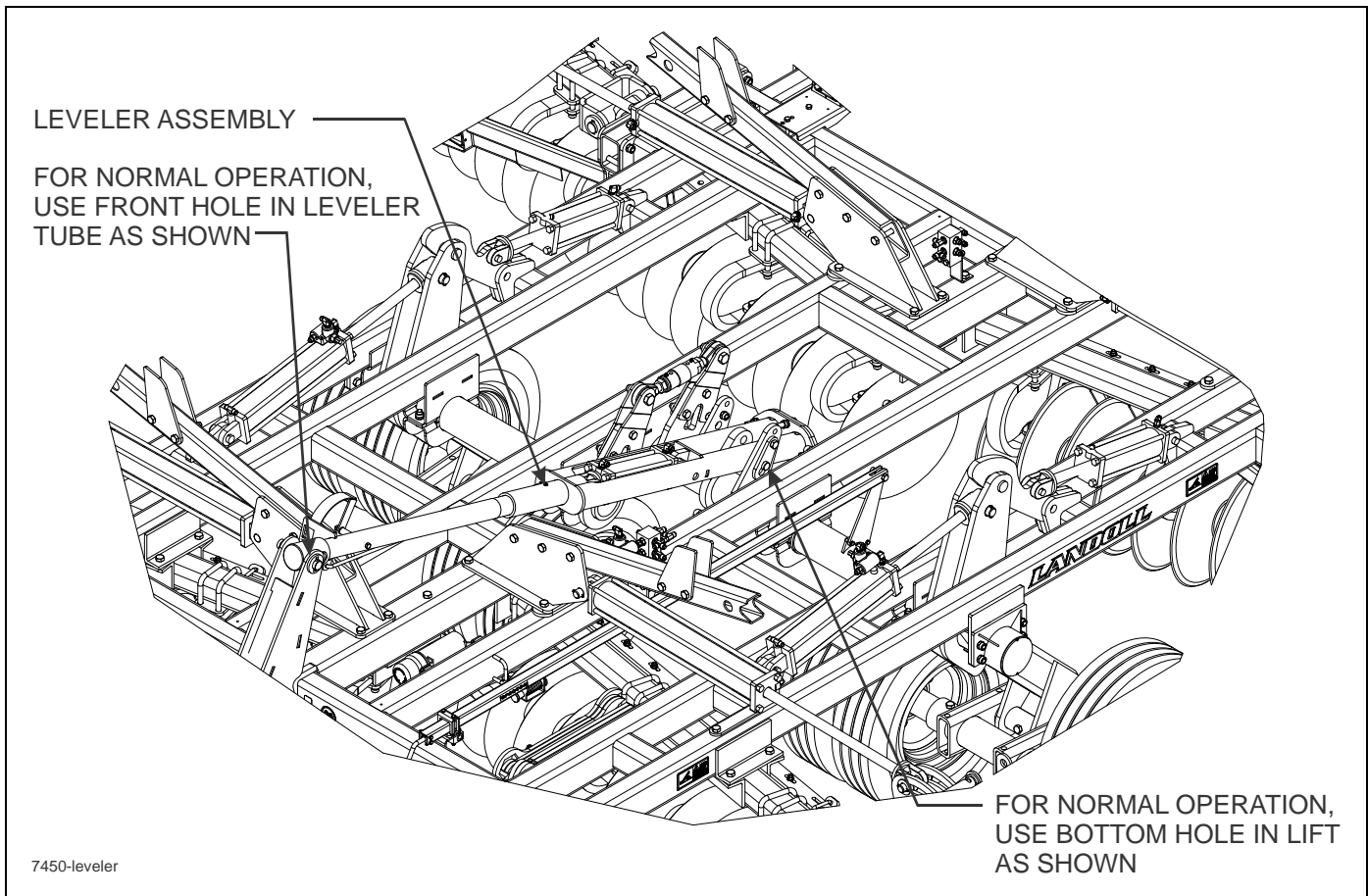

Figure 4-13: Leveling (Front to Rear)

Hitch Adjustment

1. It is important for the VT Plus to maintain a proper draft line with the tractor to do a level job of discing. The draft line will vary depending on soil conditions and tractor drawbar height. The VT Plus is equipped with an adjustable hitch to help insure a proper draft line with the tractor.
2. Generally tractor drawbars greater than 17" tall will require the hitch to be in the upper position. 17" drawbars and below should be in the lower position. Operating conditions may also influence the hitch adjustment. The hitch is most commonly located in the upper position.
3. A hitch adjustment that is too high will leave a center furrow, as the front of the VT Plus will operate too deep. A low hitch adjustment can cause a center ridge, regardless of leveler setting.

IMPORTANT

Excessive down pressure with gauge wheels can also create a center ridge regardless of hitch and leveler settings.

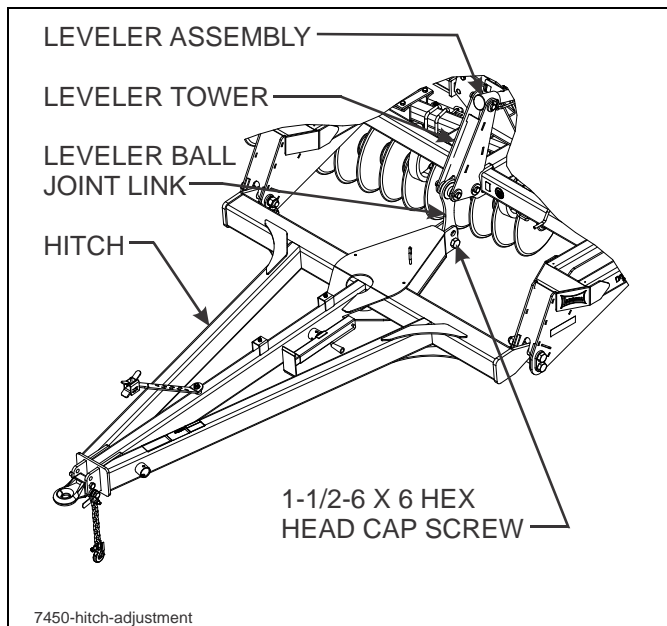

Figure 4-14: Hitch Adjustment

4. To adjust the hitch (See Figure 4-14.):
 - a. Lower the VT Plus to the ground.
 - b. Adjust the hydraulic leveler in or out until the pressure is relieved on the leveling system (See "Leveling (Side to Side)" on page 4-8 and "Leveling (Front-to-Rear)" on page 4-10).
 - c. Remove the 1-1/2-6 X 6 hex head cap screw and hardware from the leveler ball joint link at the center rear of the hitch weldment.
 - d. Loosen, but do not remove the bolts that pass through the welded bushing at the outer rear connections of the hitch.
 - e. Remove the bolt through the two hole clamp plates (above or below) the rear connections of the welded bushing
 - f. Vertically raise or lower the hitch to the desired operating position.
 - g. Reinstall the bolt through the two-hole clamp plates to secure the hitch in the new position.
 - h. Retighten all hitch bolts.
 - i. Install the bolt in the leveler ball joint link in the new position at the rear of the hitch and retighten.

IMPORTANT

When the hitch is in the lower position, the leveler ball joint link will be in the upper mounting hole at the rear of the tongue. If the hitch is in the raised mounting position, the leveler ball joint link will be in the lower hole at the rear of the tongue.

Scraper Adjustment

The VT Plus is equipped with rigid scrapers at regular spools with dual scrapers at the disc bearings.

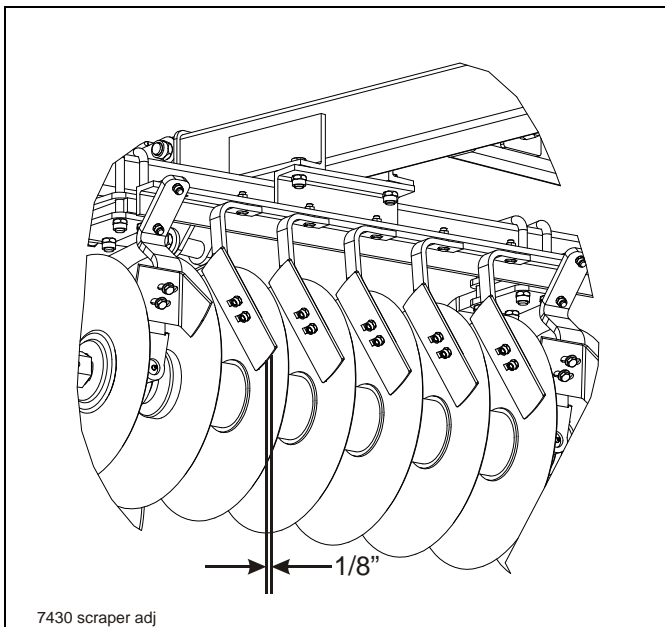

Figure 4-15: Scraper Adjustment

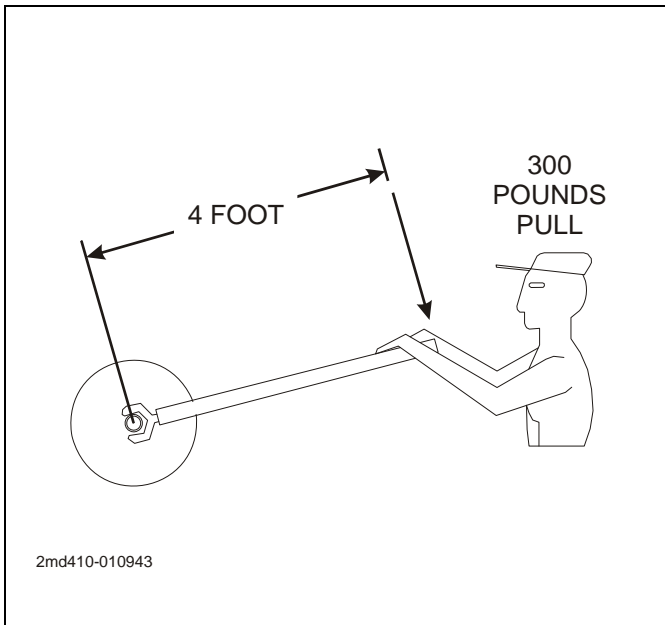

Figure 4-16: 1,250 Foot-Pounds of Torque

1. Rigid scrapers should be set initially as close to the disc blade as possible without rubbing (approximately 1/8") (See Figure 4-15.) A slotted hole at the top of each scraper is provided for individual adjustment. Adjustments may be made for entire gangs, by loosening the u-bolts around the angle-iron scraper bars and sliding the whole bar. Scraper arms are made of spring steel. In wet conditions, the scraper may be set against the disc blade and will function as a spring-loaded scraper.
2. Scraper blades have two positions and are reversible. The blades are initially set in the front position to position scraper closer to the spool. This position will perform better in wet and heavier residue conditions. The blade may be moved back for dryer conditions and climates where less scraper action is needed.
3. Dual scrapers are provided at the bearing locations to scrape the disc blade and to limit the amount of soil and residue carried into the bearing hanger. Scrapers can be individually adjusted in or out from the concave side of the disc blade.



CAUTION

Tighten all 1-3/4" nuts to 1,250 foot-pounds of torque (See Figure 4-16.)

Front Gauge Wheels

1. The VT Plus is equipped with castoring gauge wheels at the outer front corners of each wing. These gauge wheels are used to limit depth of the wings, and prevent gouging and buckling of wing frames.
2. Gauge wheels are not intended to carry the wing, but prevent excessive depth. Adjust the wheels to carry some weight, but not enough to hold the wing from reaching operating depth set with the main lift hydraulics.

IMPORTANT

Excessive down pressure can cause the implement to throw a center ridge.

3. To adjust the gauge wheel depth, loosen and adjust the nuts on the top and bottom of the frame tube (See Figure 4-17.) The top nut will have to be loosened first allowing the bottom nut to descend out of its locked position, so that it can be rotated. Once the bottom nut is adjusted up or down, retighten the top nut being sure the bottom one is inside of the lock. A wrench is provided on the implement for this adjustment. Securely tighten the adjusting nuts when complete. All gauge wheel assemblies should be set the same. Verify adjustment by measuring the length of the bolt exposed above the top nut.

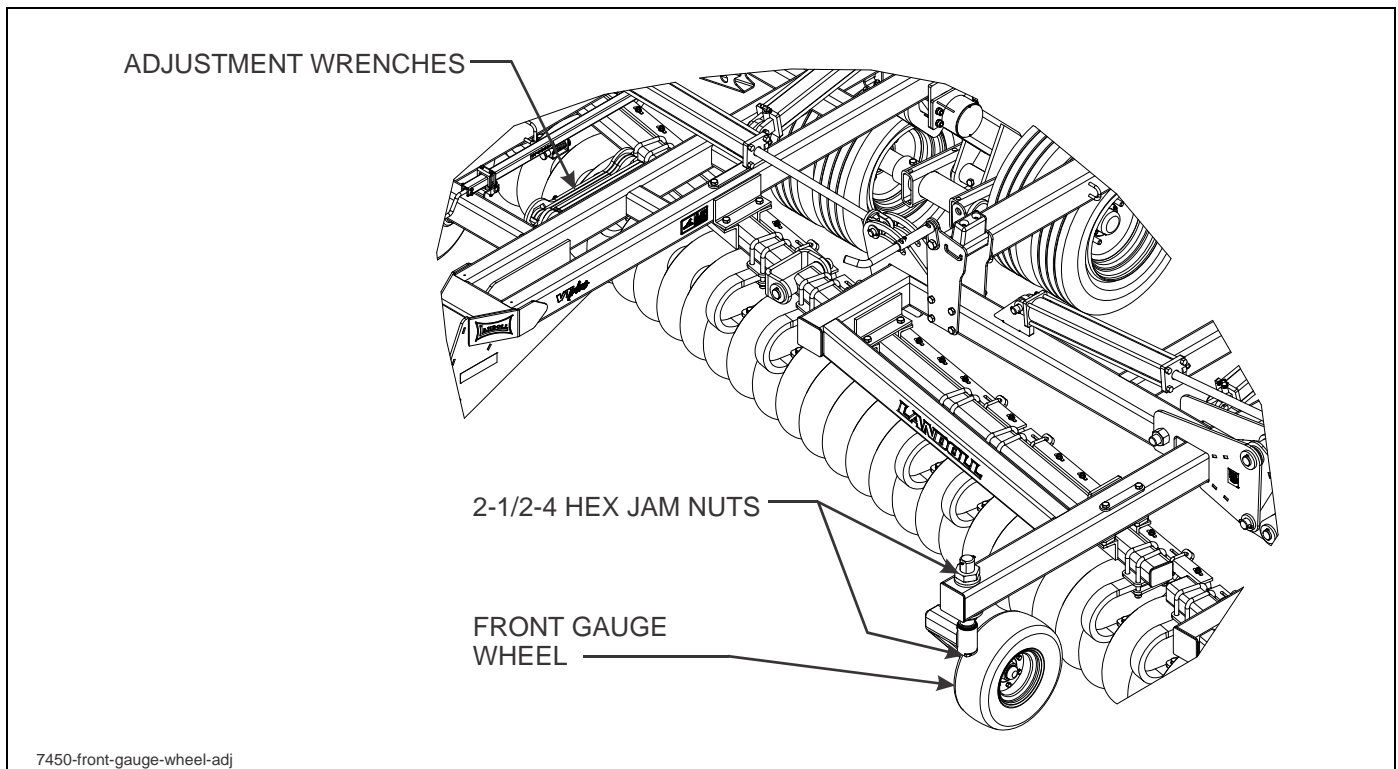

Figure 4-17: Front Gauge Wheel Adjustment

Disc Blades

1. The 7450 VT Plus is equipped with 22" -6 ga. (.197"), 22" -4 ga. (.256), or 22" -4 ga. (.256) rollable low concavity disc blades on both front and rear. The use of other concavity blades can give unpredictable results and is not recommended.
2. Sharpening – In some cases there is a desire to sharpen disc blades for improved cutting. There are several people who roll-sharpen disc blades. Most disc blades used today are made of chrome-boron steel. The chrome-boron steel has a higher hardness than traditional carbon-steel blades for increased wear. Higher hardness makes roll sharpening more difficult often with mixed results, and is not covered by warranty. Disc blade manufacturers will not cover any alterations to blades other than the place of manufacture. Results from roll-sharpening damage may not be immediate, and may take more than a season to be noticeable. If you choose to sharpen disc blades, check with local dealers for reputable experienced sharpeners that will stand behind their work.



DANGER

Disc blades are extremely sharp. Exercise extreme care when working on or near disc blades. Do not allow discs to roll over or fall onto any bodily part. Do not allow wrenches to slip when working near disc blades. Never push wrenches toward disc blades. Do not climb over machine above disc blades. Failure to stay clear of disc blade edges can cause serious personal injury or death.

Depth Stop Adjustment (Manual)

The operating depth of the VT Plus is controlled by a single-point depth stop. The stop is located at the center front of the machine.

1. Adjust the depth stop by turning the handle out (counter-clockwise) to increase operating depth (See **Figure 4-18.**) Turn the handle in (clockwise) to decrease operating depth. One turn will equal approximately 1/8" adjustment in depth.
2. The gauge on the side of the depth stop tube gives a reference for depth setting. The "A" setting refers to maximum operating depth.

IMPORTANT

For maximum operating depth, the lift wheels must be in contact with the ground and carry some of the machine weight. Raising the lift wheels off the ground, permits uncontrolled depth of each frame section and does not allow the leveler to function properly.

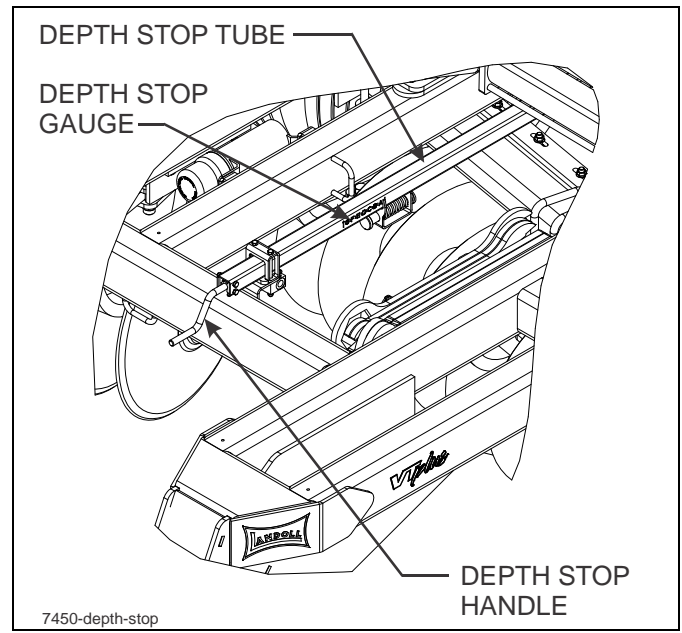

Figure 4-18: Depth Stop Adjustment (Manual)

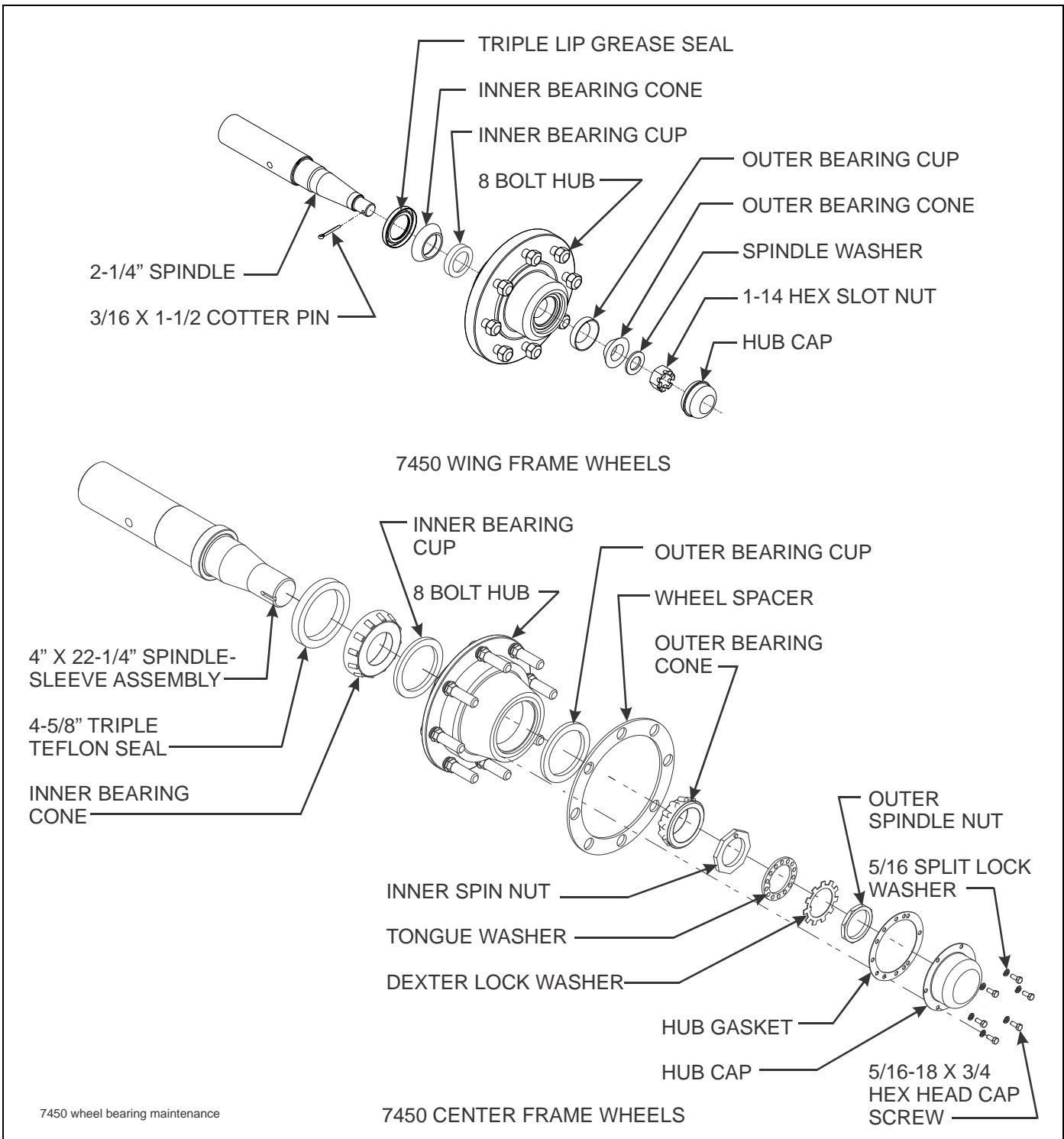

Figure 4-19: Wheel Bearing Maintenance

7450 – VT Wheel Bearing Maintenance

Center Frame

Center frame wheel bearing maintenance should be performed at the beginning of every season. Check periodically for excessive endplay. If needed, adjust or replace hub and components using the following procedure (See Figure 4-19.)

1. Lower machine until tires are off the ground, the depth stop may have to be adjusted to allow cylinders to retract far enough.
2. Remove tires.
3. Remove hub cap and catch lubricant.
4. Straighten tab of star washer, remove outer spindle nut, star washer, spindle locking washer, inner spindle nut and bearing. Remove hub from spindle.
5. Using an appropriate driver, remove inner bearing cone and seal.
6. Clean and inspect the bearings and hub cavity. Replace any worn or defective parts.
7. Repack the bearings using a high-quality wheel bearing grease. Apply grease to bearing cups and a liberal amount to the center void.
8. Install inner bearing and seal, using the correct seal driver, into hub.
9. Place the hub over the spindle being careful to align the hub bore with the spindle to prevent seal damage. Support the hub until the outer bearing cone and spindle nut are installed.
10. Torque inner nut to 100 ft.-lbs. while rotating hub to insure proper seating of bearings and cups.
11. Loosen the inner spindle nut to remove preload torque.
12. Hand tighten the inner adjustment nut until contact is made with bearing.
13. Install the spindle nut lock washer so that the dowel on the inner nut will align with a hole in the lock washer and washer tang fits in the spindle keyway.

NOTE

The spindle lock washer may be flipped over if needed to achieve a closer match to aligning with the dowel on the inner nut. Inner nut may also need to be rotated slightly for alignment.

14. Install the star washer aligning tang with spindle keyway.
15. Apply grease to one side of the outer nut and install with grease to the star washer side.
16. Torque outer nut to 300 ft.-lbs. Endplay of .001" to .010" must be present in the adjust wheel bearing assembly.
17. Bend over one tab of star washer that is aligned with a flat on the outer nut to prevent rotation.
18. Grease interior of cap lightly to prevent any corrosion.
19. Install the hub cap with the proper gasket. Tighten the cap screws of the hub cap to 15 to 20 ft.-lbs of torque.
20. Reinstall tires, making sure wheel spacer is on hub.

Wing Frame

Wheel bearing maintenance should be performed at the beginning of every season of use. Check the wheel bearings periodically for excessive end play. If needed, adjust or replace them using the following procedure **(See Figure 4-19.)**

1. Lower machine to the ground, enough to raise tires off the ground. It may be necessary to adjust depth stop to get tires off the ground.
2. Remove the tire.
3. Remove the hub cap, cotter pin, slotted nut and washer.
4. Remove the hub. Clean and inspect the bearings and hub cavity. Replace any worn or defective parts.

IMPORTANT

It is recommended to replace the seal any time the hub is removed from the spindle.

5. Repack the bearings using a high-quality wheel bearing grease.
6. Slide the seal onto the spindle. Do not install the seal into the hub.
7. Slide the inner bearing cone and hub onto the spindle.
8. Install the outer bearing cone, washer and slotted nut.
9. Tighten the slotted nut while rotating the hub until there is a slight resistance to wheel rotation. Then, back the slotted nut off one notch, until the wheel rotates freely without end play.
10. Slide the seal to the hub and install the seal in the hub.

NOTE

The seals should point away from the hub to keep contaminants out and allow grease to pass.

11. Install a new cotter pin and replace the hub cap.
12. When greasing hubs, fill hub until grease is purged from seal.
13. Reinstall tires.

Hydraulic Maintenance

1. Check the tractor hydraulic fluid level per tractor owner's manual and after any leakage. Check fluid level with the cylinders in the retracted position.
2. If a cylinder or valve leaks, before disassembling the part, contact Landoll service at 785-562-4721 for further direction. Any time a cylinder is opened up, or whenever any seal replacement is necessary, it is advisable to clean all parts and replace all seals. Seal kits are available from your Landoll dealer.
3. Check all hydraulic hoses weekly. Look for binding or cracking. Replace all worn or defective parts immediately.

IMPORTANT

Unfold, lower the unit to the ground, and relieve hydraulic pressure before attempting to service any hydraulic component.

4. Transport locks are provided to hold the implement in a raised position. Do not attempt to perform any service work under the implement without first installing the transport locks (**See Figure 4-20.**) This will require activating the fold circuit to engage the transport locks. Before servicing any hydraulic component, lower the implement to the ground and relieve all system pressure. If a hydraulic component is disconnected, repaired, or replaced, it will be necessary to purge the system of air before operation. **See “Hydraulic Lift System” on page 4-3 and “Hydraulic Fold System” on page 4-5** on how to purge the hydraulic systems.

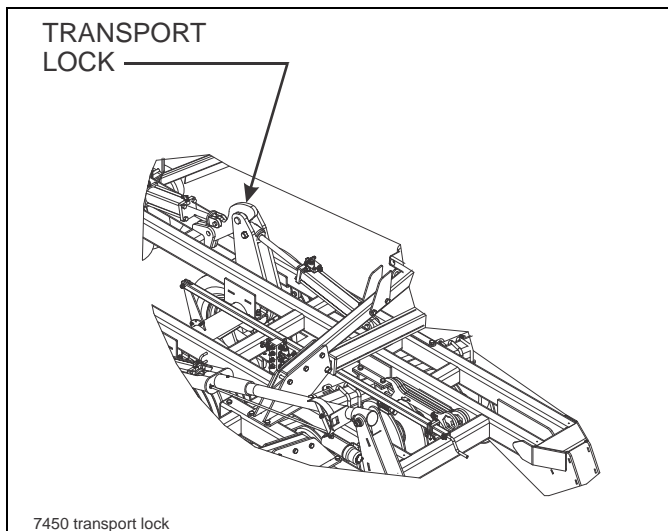

Figure 4-20: Installed Transport Locks

Transport

1. Check and follow all federal, state, and local requirements before transporting the VT Plus.
2. The 7450 should be transported only by tractor required for field operation. The implement weight should not exceed more than 1.5 times the tractor weight. **Refer to “Standard Specifications” on page 2-1** for estimated weight of each model. Maximum transport speed for the 7450 is 20 mph for the implement and is designated on the speed identification symbol located on the front of the implement (**See Figure 4-21.**)



CAUTION

1. **Excessive speed may result in loss of control of the tractor and implement, reduced braking ability, or failure of the implement tire or structure. Do not exceed the implement maximum specified ground speed regardless of the capability of the maximum tractor speed.**
2. **Due to the weight of this machine, check local bridge capacities before crossing. Approximate weights for each model are listed in the front of this manual (See “Standard Specifications” on page 2-1.)**
3. When towing equipment in combination, the maximum equipment ground speed shall be limited to the lowest specified ground speed of any of the towed implements.
4. Maximum transport speed shall be the lesser of travel speed specified in the operator's manual, speed identification symbol, information sign of towed equipment, or limit of road conditions.
5. Slow down when driving on rough roads. Reduce speed when turning, or on curves and slopes to avoid tipping. Equipment altered other than the place of manufacture may reduce the maximum transport speed. Additional weight, added tanks, harrowing attachments, etc. may reduce implement load carrying capabilities.

6. A safety chain is provided with the implement to insure safe transport.
 - a. The safety chain should have a tensile strength equal to or greater than the gross weight of the implement. The chain is attached to the lower hitch clevis hole with two flat washers between the clamp plates to assure a tight connection. Always use a 1" diameter Grade 8 bolt for this connection.
 - b. Attach the safety chain to the tractor drawbar (See Figure 4-21.) Provide only enough slack in the chain for turning. Do not use an intermediate chain support as the attaching point for the chain on the tractor. Do not pull the implement by the safety chain.
 - c. When unhitching from the tractor attach the hook end of the chain to a free link close to the hitch clevis for storage. This will keep the hook off the ground, reducing corrosion and keep the hook functioning properly.
 - d. Regularly inspect the safety chain for worn, stretched, or broken links and ends. Replace the safety chain if it is damaged or deformed in any way.
7. Check that tires are of proper size, load rating, and inflated to manufacture specifications before transporting. Check wheel lug bolts to insure tightness.

8. Know the transport heights and widths of the unit before transporting. Attachments such as leveling harrows can increase the transport dimensions of the implement. Use caution when transporting near bridges and power lines.

! WARNING

Electrocution can occur without direct contact.

9. Raise the unit to full transport height.
10. Install transport locks on both lift and fold systems. Do not depend solely on implement hydraulics for transport. (See Figure 4-22.)

! WARNING

Failure to use transport lock during transport may result in permanent equipment damage, serious injury, or death.

11. Transport during daylight hours whenever possible. Always use flashing warning lights, except where such use is prohibited by law. Make sure lights, reflectors and SMV emblem are clearly visible and operating. Remove any obstructions such as dirt, mud, stalks or residue that restricts view before transporting.
12. To increase stability and reel clearance on center frame, use hydraulic leveler to roll the unit forward.

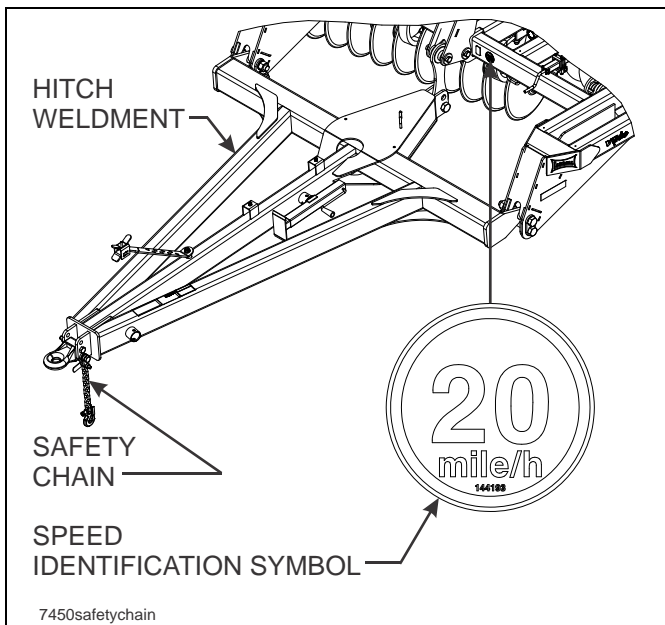

Figure 4-21: Hitch, Speed Identification Symbol, and Safety Chain

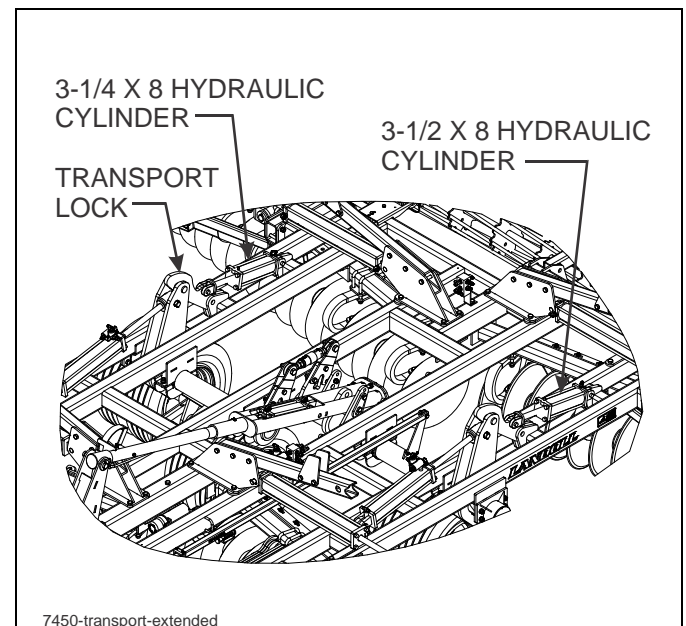

Figure 4-22: Installed Transport Locks

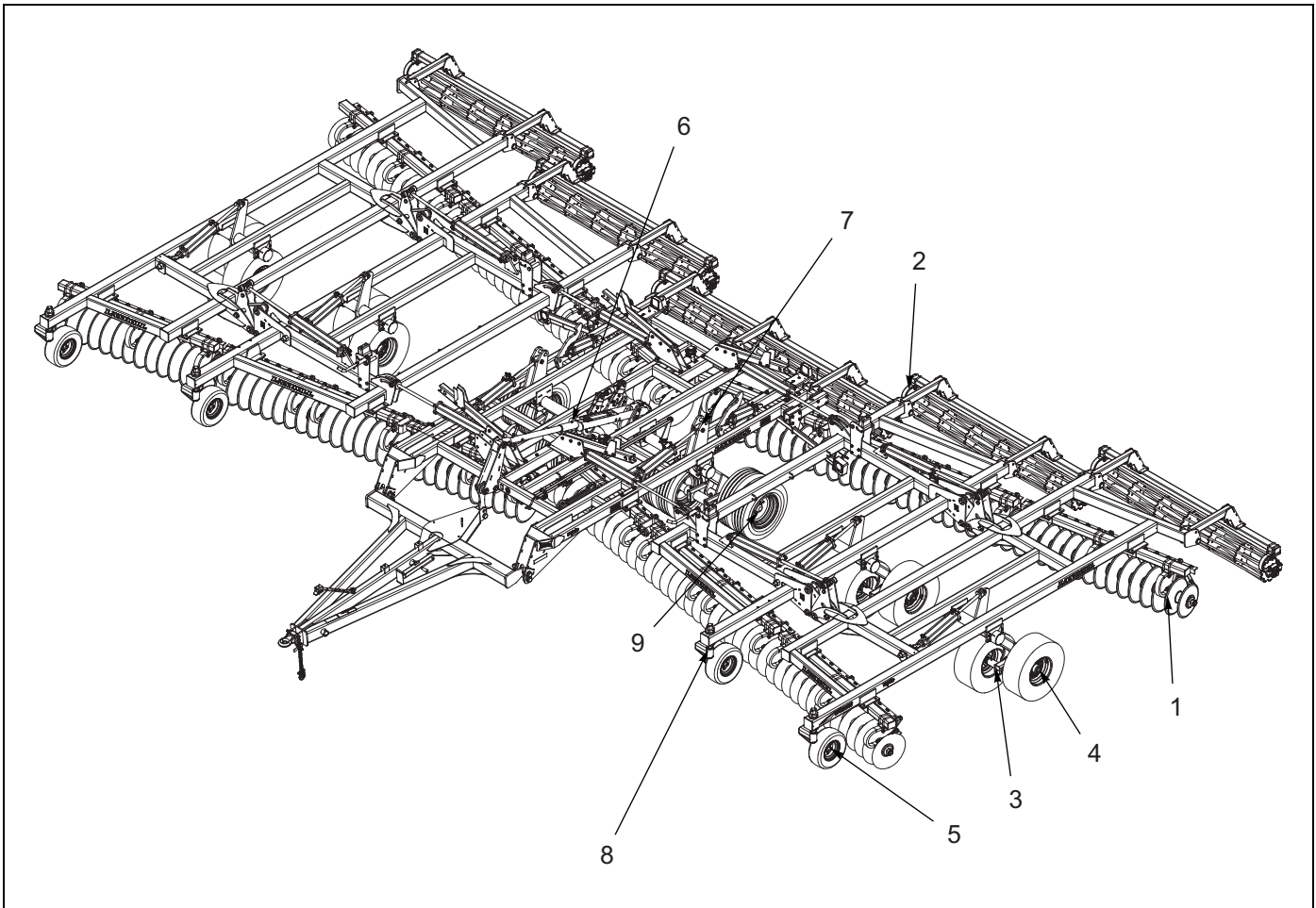

Figure 4-23: Lubrication Schedule

LUBRICATION TABLE			
ITEM	DESCRIPTION	NO. OF LUBE POINTS	INTERVAL (Hours Unless Stated)
1	Disc Gang Bearings	1 each	10
2	Conditioner Reel Bearings	1 each	10
3	Walking Tandem Hubs	1 each (Top)	50
4	Wing Wheel Hubs	1 each	50
5	Front Gauge 6 Bolt Wheel Hubs	1 each	50
6	Leveler Assembly	1	50
7	4-1/2 x 16 Lift Cylinder Rod Block	2	50
8	Gauge Wheel Pivot	4	10
9	Center Frame Hubs	1	50

Table 4-1: Lubrication Table

Lubrication Maintenance

1. **Table 4-1** specifies the number and the period of lubrication points on the 7450 VT Plus. Proper maintenance of your machine will, under normal operating conditions, help to keep it operating at or near its peak performance for an extended period of time. Proper maintenance is also a condition of keeping your warranty in good status (**See Figure 4-23.**)
2. When lubricating the VT Plus, SAE multi-purpose EP grease, or EP grease with 3-5% molybdenum sulfide is recommended. Wipe soil from fittings before greasing. Replace any lost or broken fittings immediately.
3. Disc gang and conditioner reel bearings are equipped with seals that will let grease pass and not harm the seal. Regular lubrication will maintain a full grease cavity and help purge any contaminants. Grease the bearings before long periods of storage to prevent moisture buildup within the bearing cavity.
4. Center frame hub seals will allow grease to pass without harm to seals. For wheel bearing maintenance, **refer to “Center Frame” on page 4-16.**
5. Wing wheel hub seals when properly installed will allow grease to pass without harm to seals. For wheel bearing maintenance, **refer to “Wing Frame” on page 4-17.**
6. Grease all walking tandems until grease is purged out both sides of pivot. Walking tandems must be greased daily.
7. Regular lubrication will extend service life, particularly in severe operating conditions.
8. The VT Plus is equipped with maintenance-free bearings in the lifts, leveler, wing hinges and gauge wheel casters. These areas require no lubrication.

Storage

1. The service life of the VT Plus will be extended by proper off-season storage practices. Prior to storing the unit, complete the following procedures:
 - a. Completely clean the unit.
 - b. Inspect the machine for worn or defective parts. Replace as needed.
 - c. Repaint all areas where the original paint is worn off.
 - d. Grease all exposed metal surfaces of shanks, points and discs.
 - e. Apply a light coating of oil or grease to exposed cylinder rods to prevent them from rusting.
 - f. Lubricate each point of the machine as stated in **“Lubrication Maintenance” on page 4-21.**
2. Store the unit in a shed or under a tarpaulin to protect it from the weather. The ground tools and tires should rest on boards, or some other object, to keep them out of the soil.
3. If the unit must be stored outside, unfold the VT Plus to prevent moisture buildup in the disc gang and wheel bearings.
4. If the unit is stored in the folded position, make sure the transport lock pins are installed to prevent wing frames settling.

Document Control Revision Log:

Date	Revision	End Item #	Improvement(s) Description and Comments
03/28/11	F-607	7450	Initial Release
11/02/18	F-607-1118	7450	ECN44101 Galaxy Tire/Wheel revision, wheel hub lubrication revision



Intertek

Equipment from Landoll Corporation is built to exacting standards ensured by ISO 9001 registration at all Landoll manufacturing facilities.

Model 7450 VT Plus Operator's Manual

Re-Order Part Number F-607-1118

LANDOLL CORPORATION

1900 North Street

Marysville, Kansas 66508

(785) 562-5381

800-428-5655 ~ WWW.LANDOLL.COM



Copyright 2010. Landoll Corporation

“All rights reserved, including the right to reproduce this material or portions thereof in any form.”

Scan to go to www.landoll.com

