

CX8 COMBINES

CX8.80 | CX8.90



CX threshing system with
new Ultra-Flow™ staggered drum

New CX. Tons of versatility.

The New Holland CX Series has defined super conventional combine harvesting since its launch in 2001, and almost two decades later, New Holland has redefined harvesting productivity. The new CX8 Series delivers super-sized productivity and has further elevated its already impressive capacity. The all-new optional, award-winning Ultra-Flow™ staggered drum improves threshing performance, with smoother crop flow, quieter operation, reduced fuel consumption and up to a 10% increase in capacity. Added to this are a host of in-cab controls, allowing management of the rotary separator to yield 10% higher daily productivity as well as control of the sieve opening and chop or swath selection. These new features are in addition to the industry-leading technologies of Opti-Speed™ auto-adaptive variable speed strawwalkers for tailored separation excellence, SmartTrax™, Opti-Fan™, Opti-Clean™ and Opti-Spread™ technology. Your harvest is in safe hands.



Best-in-class threshing performance.

Threshing is key when it comes to making every grain count. Thanks to four-drum technology, gentle, yet efficient threshing is guaranteed. The huge threshing drum, featuring a diameter of 29.5 inches, threshes even the toughest crop at an unbeatable rate. The concave has 111° wrapping angle and huge surface of 1,829 in.² for enhanced threshing and grain separation. Tough on threshing. Gentle on the crop. A CX8 Series is your passport to unsurpassed productivity, grain quality and straw quality!

Low-speed drum kit

For those operations where reduced grain damage is paramount, the optional low-speed drum kit enables operators to reduce the drum speed for even less cracked grain.

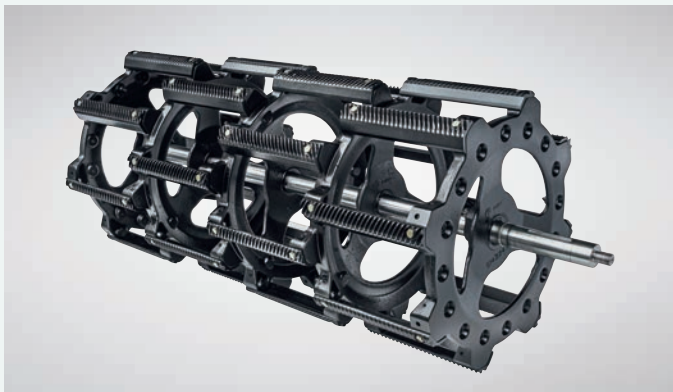







Launched and awarded: Ultra-Flow™ staggered drum for more efficient threshing

New Holland has developed the new, Agritechnica 2019 silver award-winning Ultra-Flow™ staggered drum option to enhance overall threshing performance. The sectional drum features offset rasp bars that are suitable for all grains and can be configured with covers to work with corn. This system makes for smoother crop flow, resulting in lower in-cab noise, reduced fuel consumption and a lower instance of blockages. In addition, capacity is improved by up to 10% and this is delivered within an even more durable package.

Sectional concave: easy to manage, quick to change

- Reduces the rebuilding time from 6 hours to 20 minutes, when switching between crops
- Various concave section combinations can be fitted to match a variety of crop types
- No need to remove the feeder house

Concave / Drum	Standard drum	Standard drum + cover plates	Ultra-Flow™ staggered drum	Ultra-Flow™ staggered drum + cover plates	Universal drum + Std raspbars	Universal drum + Spiked bars
						
Small Grain	✓	-	✓	-	✓	-
Corn	-	✓	-	-	-	-
Round Bar (Corn)	-	-	-	✓	-	-
Rice	-	-	-	-	-	✓

CX8 Series.

Outstanding capacity

The CX8 Series fully lives up to its title as the world's most powerful conventional combine, with up to 460hp on tap. The new, optional, award-winning Ultra-Flow™ staggered drum improves threshing performance, with smoother crop flow, quieter operation, reduced fuel consumption and 10% higher capacity. The enlarged grain tank, up to 355 bushels, and increased unloading speed enhance autonomy and harvesting flexibility. Unique in the industry, Opti-Speed™ auto adaptive variable speed strawwalkers tailor separation to the individual crop, and offer up to 10% more capacity.

Superior harvest quality

The gentle, award-winning threshing action from New Holland's four drum threshing system gently, yet thoroughly, threshes each and every ear, while preserving straw quality. New in-cab controls manage the rotary separator, the sieve opening and the chopping/swathing selection. The powerful combination of Opti-Clean™ and Opti-Fan™ technology delivers clean grain, and has enhanced cleaning efficiency by up to 20%.

Lower operating costs

The CX8 Series benefits from industry-leading technology for emissions compliance. All models are fitted with ECOBlue™ HI-eSCR 2 technology to comply with the most stringent Stage V emissions regulations to date and maintains the outstanding performance you've come to expect of the CX Series. When combined with long, 600-hour service intervals and the SmartTrax™ system for reduced soil compaction, more money stays in your pocket.

Absolute driving pleasure

The Harvest Suite™ Ultra cab has been designed to deliver ultimate harvesting comfort and ergonomics. The large 131 ft³ cab with 68 ft² of glass means more space and more glass add up to more comfortable and more precise harvesting. At 73dB(A) it is still the quietest cab on the market. The 10.4-in ultra-wide IntelliView™ IV color touchscreen monitor can be positioned on the ideal viewing arc for every operator. If you are a night-time operator, the LED Lighting package enables true, 24-hour productivity. This is all combined with a new, automotive inspired interior.

MyPLM®Connect
Telematics

Up to 27 LED work lights

Harvest Suite™ Ultra cab

Four-chain feeding system

Varifeed™ header

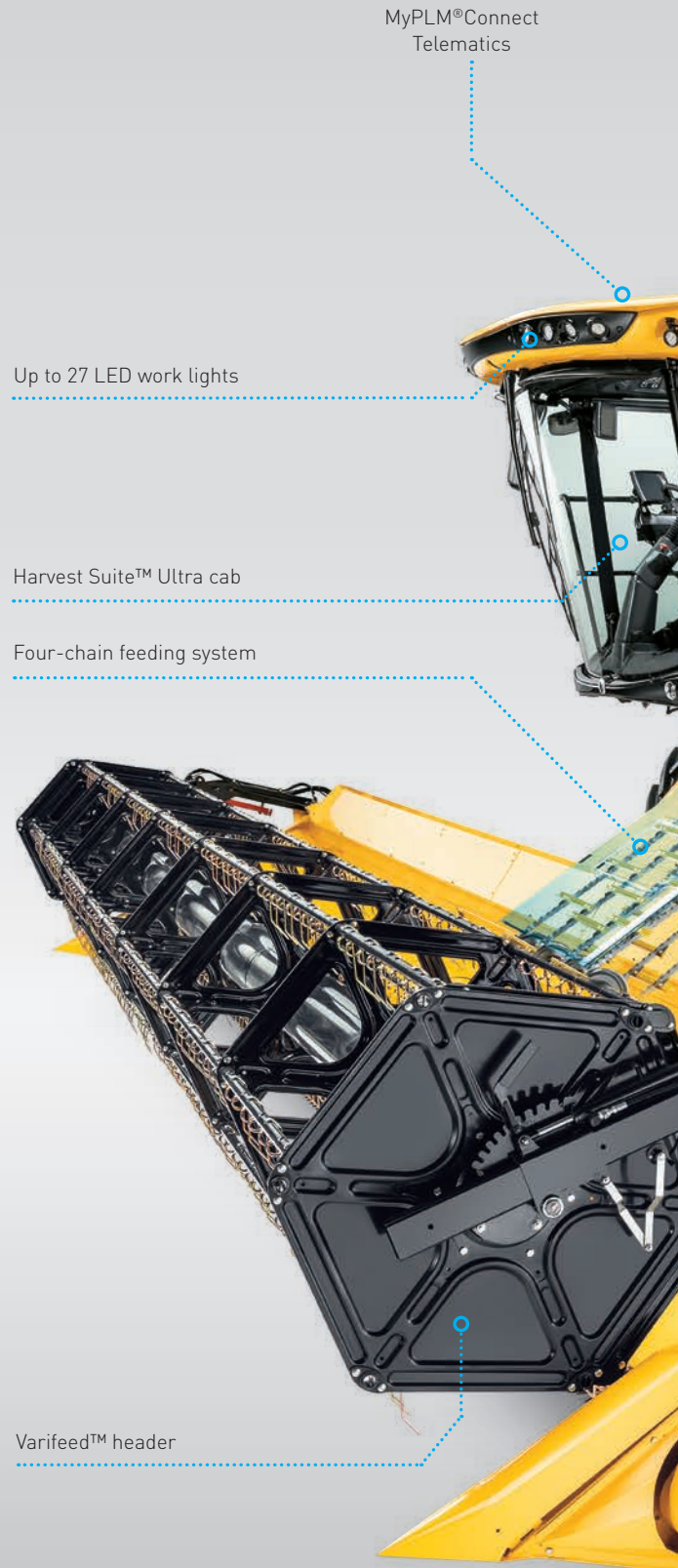



Four-drum technology including new optional Agritechnica silver medallist Ultra-Flow™ staggered drum design

Up to 355 bushel grain tank

Opti-Speed™ technology

Up to 460hp Cursor engine with ECOBlue™ HI-eSCR 2 Stage V technology

Self-leveling cleaning shoe

Opti-Spread™ system

Opti-Clean™ system

Opti-Fan™ technology

Optional New Everest Sidehill compensation system

SmartTrax™ with Terraglide™ suspension available

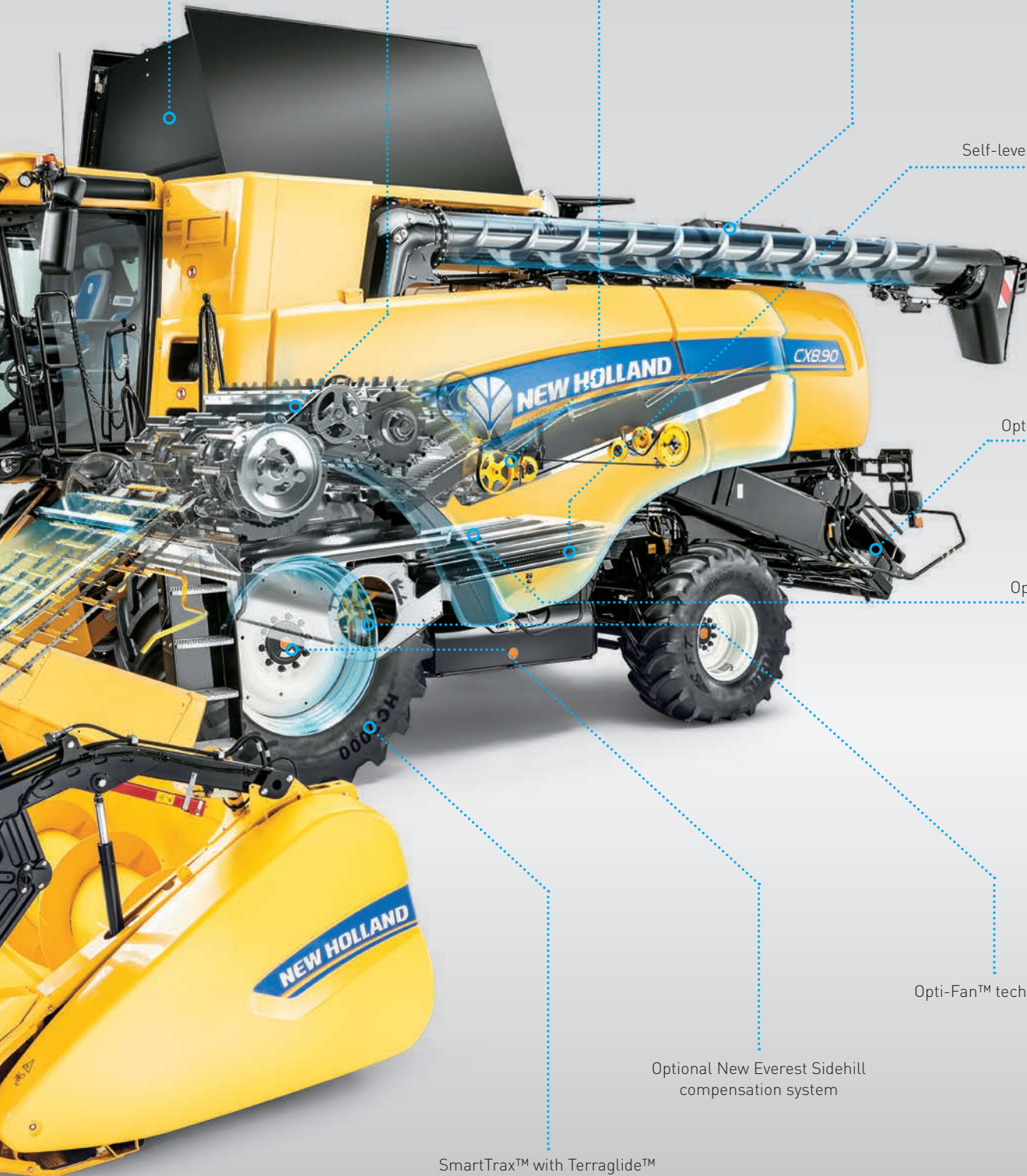

High-volume grain management.

The 355-bushel grain tank is now produced in New Holland trademark harvesting yellow. Electronically folding grain tank covers come as optional and are activated from the comfort of the cab. The covers reduce grain losses when working on steep inclines and when closed help to seal out water. The bubble-up auger evenly distributes grain in the tank and renders air pockets and grain banks a thing of the past.

Grain tank		CX8.80	CX8.90
Folding covers capacity	(bu)	326	355
Manual extension capacity	(bu)	350	350

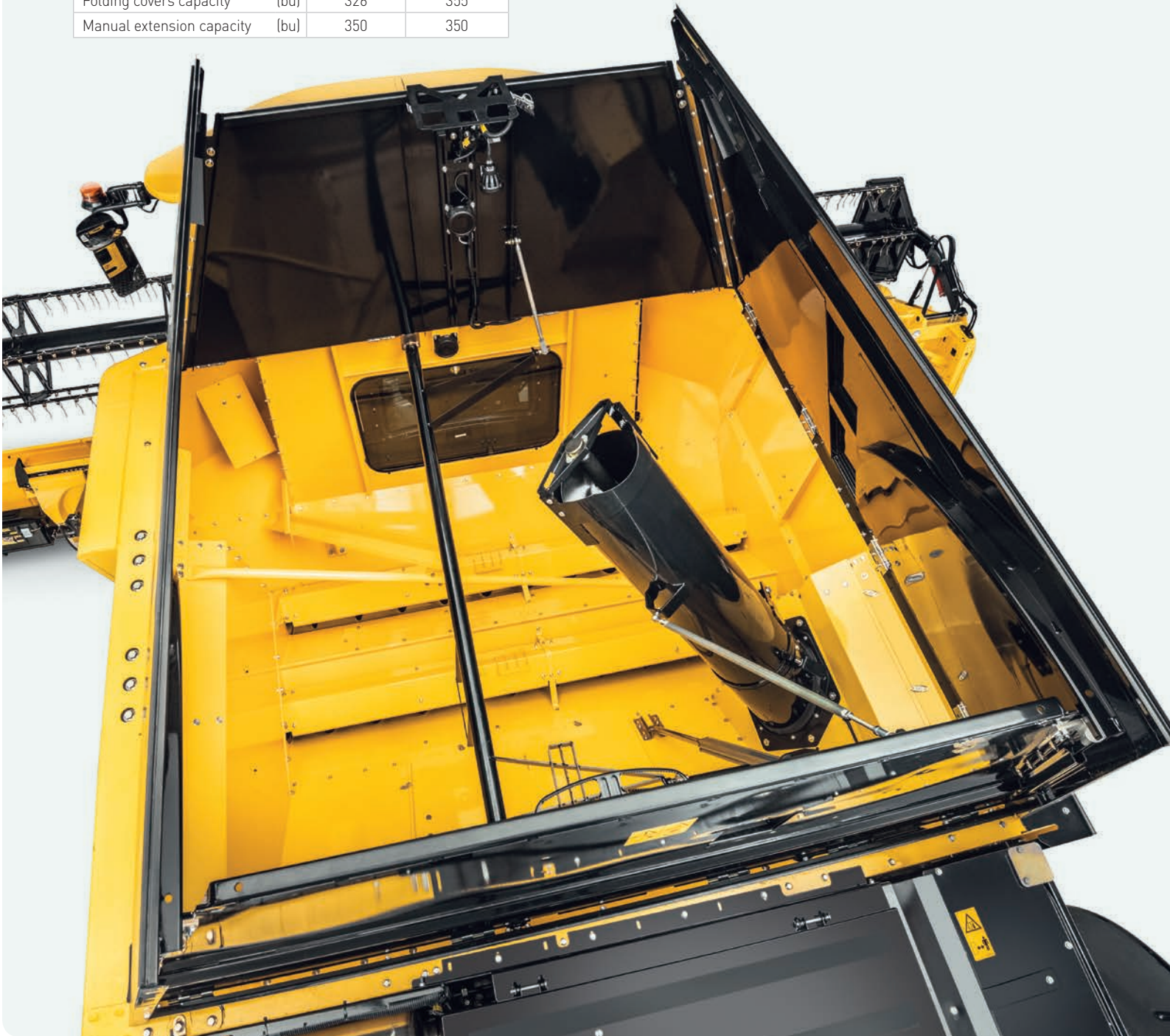

Uniform chopping, ultra-wide spreading.

Spreading wide. Always.

- The new, patented, air-flow based chaff spreader can spread the chaff across the entire width of the header. The speed of the disks can be controlled from the cab in response to crop or wind conditions, and spread chaff up to 45 feet wide.
- The straw chopper spreading width can be adjusted on-the-go through the in-cab controlled deflector.

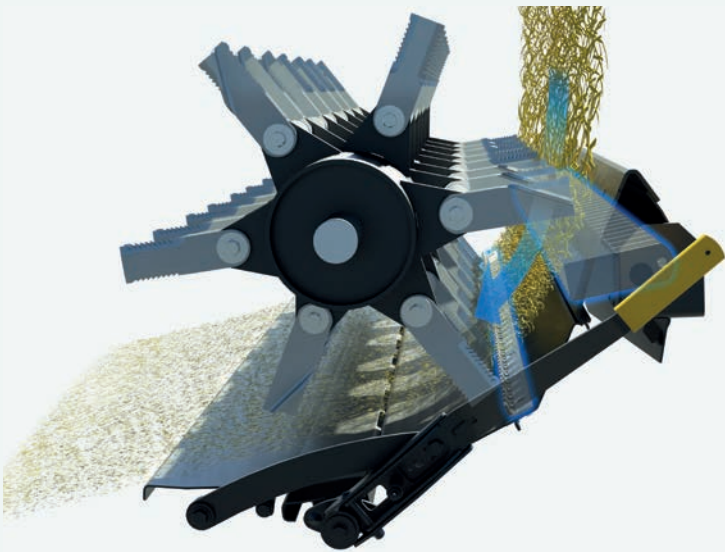

Super-fine chopping

- The straw chopper comes in two versions, with 4 or 6 rows of knives, to match residue management needs on all crop conditions.
- The Dual-Chop™ system features a rake through which the razor sharp blades pass to ensure super-fine chopping of all material



Perfect bales

- The Multi-Thresh™ system guarantees gentle crop handling, maintaining straw structure and minimizing breakages
- The concave adjustments now can be made from the cab and on-the-go according to the crop requirements
- Changing between chopping and swathing is managed at the touch of a button

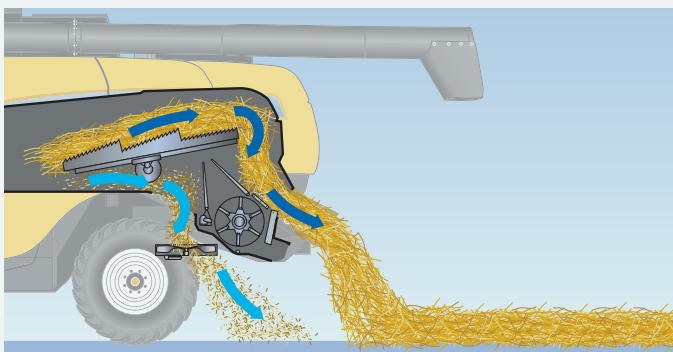

More power and top efficiency.

Through the Clean Energy Leader® strategy, the entire CX Series is fitted with ECOBlue™ HI-eSCR 2 technology to comply with the most stringent Stage V emissions. The proven ECOBlue™ technology uses AdBlue to transform the harmful nitrogen oxides contained in the exhaust gas into harmless water and nitrogen. This after-treatment system is separate from the engine, which means the engine only breathes clean, fresh air. The result? Clean-running power improves performance and enhances fuel economy.

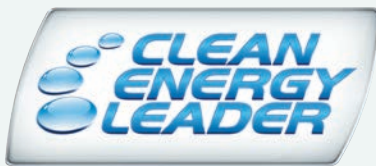

Sustainable Efficient Technology

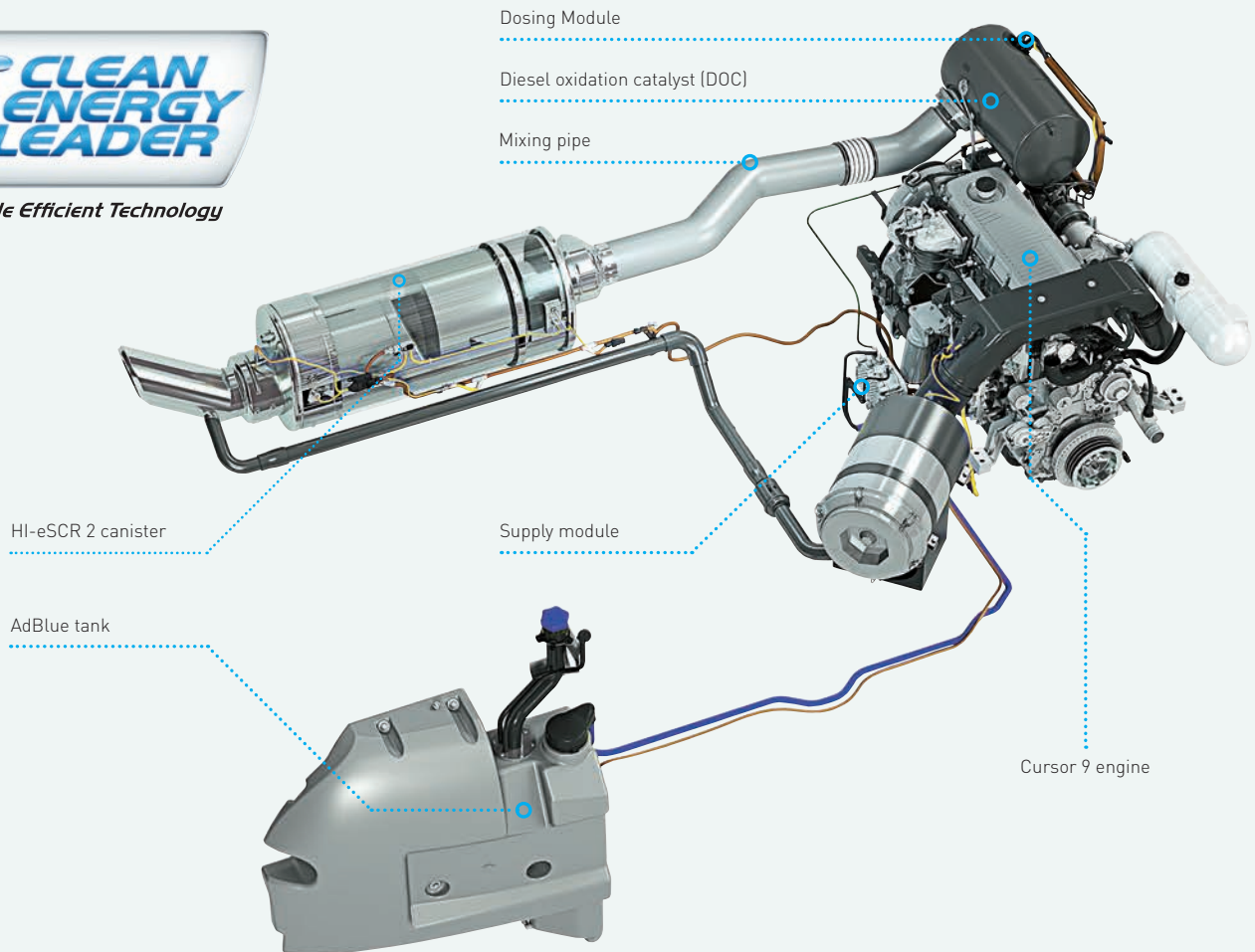

Models		CX8.80	CX8.90
Engine*		FPT Cursor 9*	FPT Cursor 9*
Displacement	cu.in. (L)	531 (8.7)	531 (8.7)
Compliant with emission regulations		Stage V	Stage V
ECOBlue™ system (Selective Catalytic Reduction)		HI-eSCR 2	HI-eSCR 2
Injection system		Common Rail	Common Rail
Gross engine power @ 2100rpm	hp (kW)	354 (260)	420 (308)
Maximum engine power @ 2000rpm	hp (kW)	394 (290)	460 (338)
Approved biodiesel blend**		B7	B7

* Developed by FPT Industrial

** Biodiesel blend must fully comply with the latest fuel specification EN14214:2009 and operation is in accordance with operator manual guidelines

ECOBlue
HI-eSCR2

A new benchmark for harvesting comfort.

The CX8 Series of combines offers you a home-away-from-home during long harvesting days. The Harvest Suite™ Ultra cab is completely new from the floor up and is the result of extensive customer consultation. Cab volume has increased to 131 cubic feet and includes 68 square feet of glass, 7% more than previous models. You can enjoy all that space in the peace and quiet of the near-silent 73dB(A) cab. The new, automotive-inspired interior features an ultramodern dark grey color scheme, which has been extended to the seat, headliner and armrest.

Stay refreshed on the hottest days

- The large portable fridge under the instructor seat can be easily removed for replenishment
- Air conditioning comes as standard, or upgrade to the optional Automatic Climate Control system that automatically adjusts fan speed to guarantee accurate temperature control

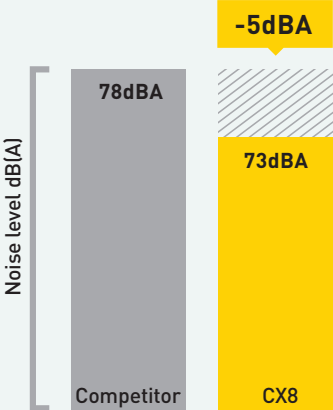

360° panoramic view

- The Harvest Suite™ Ultra cab's wide curved window offers a perfect view
- The floor slopes down into the front windscreen so that you have a clear view of the edge of the header
- Standard electric mirrors present a wide viewing arc to the sides and rear
- Up to three optional viewing cameras can be managed through the IntelliView™ IV monitor, and one has been pre-wired for reversing



Effortlessly maximizing performance.

Intelligent and intuitive automation saves times and enhances harvesting performance. The CommandGrip™ multifunction handle means you can perform a full day of harvesting with minimum fatigue. All key machine and header parameters can be controlled, including header height, reel position and unloading engagement. The right-hand console contains less frequently used functions, which are laid out in an ergonomic and logical manner. Machine functions can be analyzed at a glance courtesy of the color IntelliView™ IV monitor.



Shift button and ground speed unlock (behind)



Force based movement enables the operator to change speed and direction

Wide-screen harvesting

The ultra-wide 10.4-inch IntelliView™ IV color touchscreen monitor is fixed on rollers, which can move along an ideal viewing arc so you can position it where you want. This intuitive, color touchscreen displays and monitors all combine functions and parameters, all of which can be easily adjusted by touching the screen. A second screen can be installed on request and is perfect for IntelliSteer® auto guidance tasks and mapping follow-up.



10.4-inch wide IntelliView™ touch screen monitor

Variable header / feeder speed adjustment

Road / Field mode

Drum speed control



2 USB charging ports are available

Reel speed synchronization



Concave position

IntelliSteer® guidance activation

Rotary Separator concave position

Open / close grain tank cover

Cleaning fan speed

Grass seed unload

Pre-sieve opening

Upper sieve opening

Lower sieve opening

Chaff spreader speed

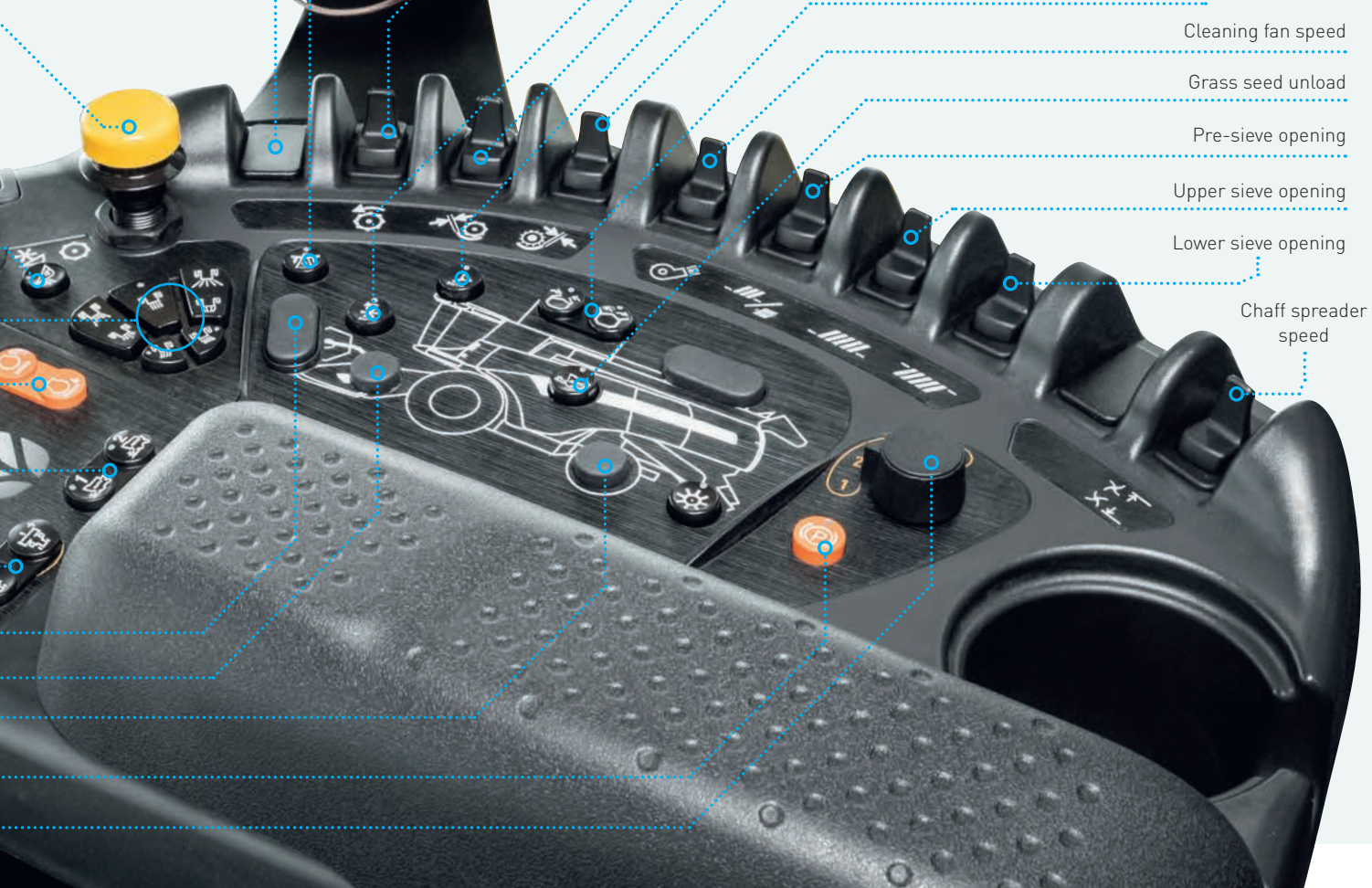

New Holland guidance systems to match your needs.

A full range of guidance solutions are available from New Holland and include manual and assisted guidance. You can even specify your CX8 with fully integrated IntelliSteer® auto guidance direct from the factory to start saving money from your first run. Fully compatible with the most accurate RTK correction signals, IntelliSteer can guarantee pass-to-pass and year-to-year precision to as low as sub-inch accuracy.

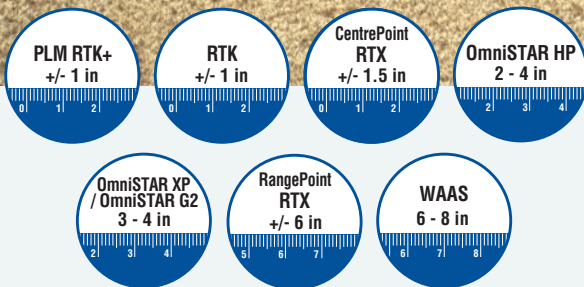

Levels of accuracy and repeatability

New Holland offers multiple levels of accuracy. This enables you to select the right IntelliSteer® system to match your needs and budget. When using RTK correction with IntelliSteer you can enjoy guaranteed year-on-year repeatability.



RTK base station

An RTK base station can be used to broadcast a correction signal to achieve a pass-to-pass accuracy of sub-inch accuracy.

MyPLM[®]Connect Telematics: manage your machine from the comfort of your office.

MyPLM[®]Connect enables you to connect to your CX from the comfort of your office through a mobile network. You can stay in touch with your machines at all times, and you can even send and receive real-time information that saves time and enhances productivity. The entry-level MyPLM[®]Connect Essential package offers the most frequently used features, or upgrade to the MyPLM[®]Connect Professional package for full machine monitoring and control. MyPLM[®]Connect will help you to reduce your fuel bills and improve fleet management and security in one simple package.



MyNew Holland[™]

Manage your MyPLM[®] applications and your entire farm operation, equipment and support through one centralized location. **MyNewHolland.com** provides the infrastructure to connect your farming operation and share information while using MyPLM[®]Connect Telematics to manage your fleet logistics, utilization and productivity. Key MyNew Holland[™] features include:

- MyPLM[®]Connect
- MyPLM[®] Customer Support
- Product guides and manuals
- Warranty documents
- MyPLM[®] training materials
- Frequently Asked Questions

Real-time data recording

New Holland offers a variety of precision farming packages to tailor your inputs to reduce your costs and increase your yields. This information is recorded in real time by your machine during work. It is then simply and efficiently transferred for analysis by the computer package from the IntelliView[™] IV monitor via the complementary 4GB USB stick, which is large enough to record data from over 1,500-1,750 acres.

MODELS		CX8.80	CX8.90
Header control systems			
Automatic stubble height control		Automatic	Automatic
Compensation mode		●	●
Autofloat™ III system		●	●
Straw elevator			
Number of chains		4	4
Power Reverse hydraulic header and elevator reverser		Hydraulic	Hydraulic
Lateral flotation		●	●
Harvest Suite™ Ultra cab glass area			
	ft. ²	68	68
Cab category level - EN 15695		2	2
Halogen working lighting pack		●	●
LED working lighting pack		○	○
LED long distance lights		○	○
Standard cloth trimmed seat with air-suspension		●	●
Deluxe cloth trimmed heated air-suspension seat with Active Ventilation		○	○
Leather trimmed heated air-suspension seat with Active Ventilation		○	○
Leather steering wheel		○	○
IntelliView™ IV monitor with adjustable position		●	●
2nd IntelliView™ IV monitor		○	○
3 viewing cameras		○	○
ACS (Automatic Crop Settings)		●	●
Automatic climate control and removable fridge		●	●
MP3 Bluetooth radio / Satellite radio (hands free phone calls)		○	○
2 x USB charging ports		●	●
Optimum Cab Noise level - 77/311EEC	[dB(A)]	73	73
New Holland Precision Land Management systems			
MyPLM® Connect Telematics		○	○
IntelliSteer™ automatic guidance system		●	●
IntelliCruise™ II system		○	○
Yield measuring and moisture measuring, DGPS yield mapping		●	●
PLM® Desktop software and software support service		●	●
Threshing drum			
Width	in. (m)	62 (1.56)	62 (1.56)
Diameter	in. (m)	29.5 (750)	29.5 (750)
Standard type / Universal type / Ultra-Flow™ staggered type		● / ○ / ○	● / ○ / ○
Number of bars		10	10
Speed range	(rpm)	305 - 905	305 - 905
Low speed drum kit (optional)	(rpm)	245 - 745	245 - 745
Drum concave			
Sectional Concaves		○	○
Area	in. ² (m ²)	1829 (1.18)	1829 (1.18)
Number of bars		16	16
Wrap angle	(degrees)	111	111
Beater			
Four paddle and four teeth drum diameter	in. (m)	18.75 (0.476)	18.75 (0.476)
Beater concave area	in. ² (m ²)	450 (0.29)	450 (0.29)
Rotary Separator			
Diameter	in. (m)	28 (0.72)	28 (0.72)
Two Speed quick change without tools	(rpm)	387 / 700	387 / 700
Concave area (including rake)	in. ² (m ²)	1441 (0.93)	1441 (0.93)
Multi-Thresh™ system with in-cab control		●	●
Total powered separation area	in. ² (m ²)	3937 (2.54)	3937 (2.54)
Straw Flow™ beater		●	●
Strawwalkers			
Number		6	6
Opti-Speed™ variable strawwalkers		●	●
Separation area	in. ² (m ²)	9192 (5.93)	9192 (5.93)
Cleaning			
Self-levelling cleaning shoe		○	○
Opti-Clean™ cleaning system		●	●
Grain pan removable from front		●	●
Pre-cleaning system		●	●
Total sieve area under wind control	in. ² (m ²)	10,075 (6.5)	10,075 (6.5)
Remote control sieve and presieve setting		○	○
Cleaning fan			
Opti-Fan™ system		●	●
Number of blades		6	6
Fan drive		Hydraulic	Hydraulic
Self-levelling cleaning shoe variable speed range	(rpm)	200 - 1100	200 - 1100

MODELS		CX8.80	CX8.90
Return system			
Roto-Thresher™ system	(Number of rotors)	2	2
Returns indication on IntelliView™ IV monitor		●	●
Grain tank			
Remote folding covers capacity	bushels	326	355
Manual folding extensions capacity	bushels	350	350
Unloading auger			
Unloading speed	bu/sec	3.5	3.5
Unloading auger swivel reach	(degrees)	105	105
Pivoting spout system		○	○
Electrical			
12 volt alternator Standard/Optional	(Amps)	190	190
Battery capacity	(CCA / Ah)	730 / 2x107	730 / 2x107
Engine*			
		FPT Cursor 9*	FPT Cursor 9*
Compliant with emission regulations		Stage V	Stage V
Displacement	cu. in. (l)	531 (8.7)	531 (8.7)
ECOBlue™ SCR system (Selective Catalytic Reduction)		HI-eSCR 2	HI-eSCR 2
Injection system		Common Rail	Common Rail
Gross engine power @ 2100rpm - ISO 14396 - ECE R120	[kW/hp(CV)]	260/354	308/420
Max. engine power @ 2000rpm - ISO 14396 - ECE R120	[kW/hp(CV)]	290/394	338/460
Approved Biodiesel Blend		B7**	B7**
Fuel tanks			
Diesel capacity / AdBlue capacity	(gal)	265 / 45	265 / 45
Transmission			
4 speed gearbox		●	●
Differential lock		●	●
Powered rear wheels		○	○
Maximum speed standard / optional	(mph)	19 / 25	19 / 25
SmartTrax™ rubber tracks with Terraglide™ suspension		○	○
Residue management			
Remote adjustable spread board deflectors		○	○
Remote chop / drop selection		○	○
Chaff spreader with in-cab adjustment		●	●
Weight			
Standard version on tires, less header and less strawchopper	(lbs)	34260	35350

● Standard ○ Optional — Not available *Developed by FPT Industrial

**Biodiesel blend must fully comply with the latest fuel specification EN14214:2009 and operation is in accordance with operator manual guidelines

MODEL DIMENSIONS

		CX8.80 / CX8.90	
		Tires	SmartTrax with Terraglide suspension
With traction wheels / tracks ^(A)		900/60R32	34"
Ground contact area	sq.ft. (m²)	—	22.7 (2.11)
Max height in transport position	ft. in. (m)	13 (3.96)	13 (3.96)
Max width - transport	ft. in. (m)	12'10" (3.9)	12'10" (3.97)

(A) Traction wheels other than those mentioned are also available





VALUE, SERVICE AND SOLUTIONS

There's a certain way of thinking that comes from living on a farm. Farming takes equal parts brain and brawn. Not to mention thick skin, calloused hands and a fair share of know how. Seasoned farmers know it helps to have equipment that's built by farmers, sold by farmers and used by farmers.

Support at every step. When you place your confidence in New Holland agricultural equipment, you get the finest in local support. Your New Holland dealer understands the many challenges you face and stands behind you at every step with the equipment, parts, service and financial solutions to make your job easier. Look to New Holland for a complete selection of equipment, including a full line of tractors, hay & forage equipment, harvesting, crop production and material handling equipment.

Quality parts and service. Turn to your New Holland dealer after the sale for expert, factory-trained service and genuine New Holland-branded parts. Your dealer has the very latest service updates and training to ensure your equipment keeps working productively season after season.

Financing solutions. Your New Holland dealer can tell you about smart ways to turn your financial challenges into opportunities with a portfolio of innovative financial services available through CNH Industrial Capital, including customized financing, leasing, insurance and the purchasing convenience of a Commercial Revolving Account.

For reliable equipment, parts and service — or just honest advice on farming and finance — turn to New Holland and your trusted New Holland dealer. We know. We're farmers, too.



We are proud to support the FFA.

Learn more at www.newholland.com/na

Design, materials and/or specifications are subject to change without notice and without liability therefor. Specifications are applicable to units sold in Canada, the United States, its territories and possessions, and may vary outside these areas.

© 2019 CNH Industrial America LLC. All rights reserved. New Holland is a trademark registered in the United States and many other countries, owned by or licensed to CNH Industrial N.V., its subsidiaries or affiliates. Any trademarks referred to herein, in association with goods and/or services of companies, other than owned by or licensed to CNH Industrial N.V., its subsidiaries or affiliates, are the property of those respective companies.



Safety begins with a thorough understanding of the equipment. Always make sure you and your operators read the Operator's Manual before using the equipment. Pay close attention to all safety and operating decals and never operate machinery without all shields, protective devices and structures in place.