

X4 F/VI/GE

90 - 100 - 110 - 120



Power
Technology

McCORMICK

McCORMICK X4F/V/GE, FEATURING THE DEUTZ TCD SERIES ENGINE

The X4F/V/GE series is powered by the new Deutz TCD L4 2.9L four-cylinder engines. With four valves per cylinder, turbo Intercooler and common rail injection system, these engines deliver more power, higher torque backup and better fuel economy, resulting in great flexibility of use.

The four models in the range provide power ratings from 90 to 112 max hp at 2200 rpm. The fuel consumption is reduced to a minimum as a result of the Engine Memo Switch, a device which allows the operator to store and recall the engine speed most suited to the implement used, and due to the absence of DPF regeneration system.

EGR + DOC system: exhaust emissions under control

An innovative exhaust gas recirculation system (EGR) combined with a diesel oxidation catalyst (DOC) allows the Deutz TCD L4 engines to meet the Tier 4 emissions regulations without the use of a diesel particulate filter (DPF), thus eliminating the need for a regeneration process.

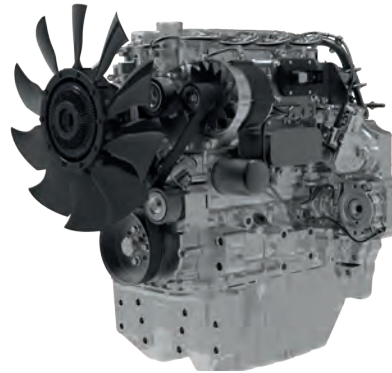

This range is available in ROPS version for the F and GE models and in cab version for the F and V models.

The range offers a choice of transmissions and a variety of frames providing different wheelbase sizes, ground clearances and track widths. The series comes in three models to suit specific applications:

F model for orchards and vineyards with wider row spacing.

GE model for low orchards: perfect for moving under low-hanging branches.

V model for vineyards: specially designed to operate between vineyard rows.

X4F



• Min. Width 52.8 in

X4GE

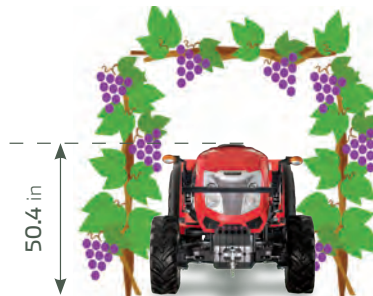

• Min. Width 33.2 in

X4 V



• Min. Width 39.5 in

HYDRAULIC SYSTEM - CAB

UP TO 29 GPM (110LPM) TOTAL FLOW

HYDRAULIC SYSTEM - ROPS

20.6GPM (78LPM) TOTAL FLOW

OPERATOR'S AREA

CAB AND ROPS OPTIONS

ENGINE

DEUTZ, 2.9L



FRONT AXLE

4-WHEEL DRIVE

TRANSMISSION

MECHANICAL OR POWER SHUTTLE

REAR HITCH - CAB

5,952 LB (2700 KG) LIFT

REAR HITCH - ROPS

5,732 LB (2600 KG) LIFT

More comfort means more productivity. That's why McCormick has developed the Deluxe cab: a true mobile office where working becomes enjoyable. The Deluxe cab is a four-post design with rear-hinged doors that provide ease of access to the driving seat and unequalled all-round visibility. With its flat-deck platform, fully adjustable driving position, ergonomic controls and automotive-grade fit and finish, the X4F cab offers the operator a comfortable workplace all year round and in all weather conditions.

HIGHLIGHTS

- › Spacious and comfortable cab with flat-deck platform
- › Best-in-class heat and sound insulation
- › Four-post design for unmatched all-round visibility
- › Category 4 protection for maximum operator safety during pesticide spraying available
- › Ergonomic arrangement of all controls
- › Air-suspension seat and tilt-adjustable telescopic steering wheel
- › Automotive-style fit and finish for maximum comfort



DELUXE DRIVING POSITION WITH ERGONOMIC CONTROLS

The driver's seat is equipped with air suspension providing for maximum seating comfort. The telescopic tilt-adjustable steering wheel is designed to tilt with the instrument panel. The joystick and all control levers and pedals are ergonomically positioned for maximum ease of operation.



MORE COMFORT, BETTER CONTROL, GREATER PRODUCTIVITY

The interior of the X4F & V cabs is inspired by the automotive industry to offer the operator a more comfortable driving and working environment. The digital instrument panel keeps the operator constantly informed on the tractor performance. This reduces fatigue and stress, allowing the operator to stay focused on the task at hand, resulting in increased productivity.



QUIETNESS AND SAFETY ON BOARD

The X4F & V feature an excellent soundproofing and pressurisation system which converts the Deluxe cab into a clean, quiet and dust-free working environment. In addition, an activated carbon filter with category 4 filtration is available to protect the operator from contamination during the application of pesticides.



EXCELLENT CLIMATE CONTROL

A highly-efficient climate control system, built into the cab roof, maintains the desired cab temperature whatever the outdoor weather conditions. The climate controls are conveniently integrated into the overhead console on the driver's left-hand side. Natural ventilation is ensured by the opening front and rear windscreens.



VERSATILE TRANSMISSION TO SUIT EVERY NEED



CHOICE OF SYNCHRO OR POWER SHUTTLE

The X4F tractors are fitted standard with a mechanical shuttle. Optionally available is an electrohydraulic power shuttle with response modulation to suit operating conditions.



MODULATED PTO ENGAGEMENT FOR INCREASED OPERATOR COMFORT

The rear PTO offers two speeds: 540 and 1000 with groundspeed PTO option on cab models. A power-assisted button enables smooth and modulated engagement of the PTO. This ensures a soft start-up of the implement for greater operator comfort.

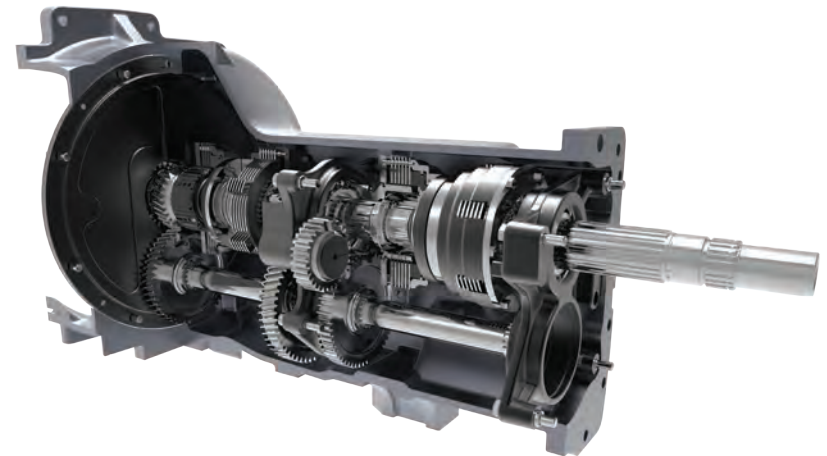

INNOVATIVE HYDRAULIC SYSTEM FOR MAXIMUM FLEXIBILITY

The X4F and V come with a variety of hydraulic options and configurations to offer farmers tailored solutions for their applications. The hydraulic system of this range comes standard with a double pump that supplies 13.2 gpm (50 l/min) to the rear hitch and remotes and 7.4 gpm (28 l/min) to the steering system. Optionally, it can be equipped with a triple pump that provides a flow rate of 10.8+10.8+7.4 gpm (41+41+28 l/min) to operate, respectively, the rear hitch and remotes, the front remotes and the steering system. The tractor can be equipped with up to seven remote valves, four at the rear and three at the front. Available options include three electrohydraulic front remotes, a flow selector to control multiple outlets with a single control and a flow divider to regulate the flow rate to the remotes. The F and V cab models are available with rear hydraulic stabilizers which control opening and closing of the lower links via two simple push-buttons. This function can be useful when attaching implements or when hitch adjustment during inter-row operation is required. The Category 2 three-point hitch offers a lift capacity of 5,952 lbs (2700 kg)

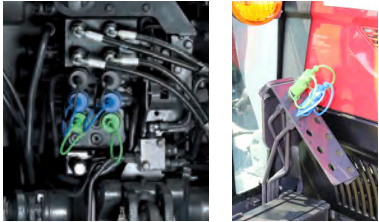

PRACTICAL QUICK COUPLINGS

The high-quality quick-release couplings, mounted on both the front and rear of the tractor, are easily accessible for convenient and fast **operation**.



CONVENIENT HITCH CONTROLS ON FENDERS

The hitch controls are located on the rear fenders making it easier to attach implements from the ground with electronic hitch control option.



A JOYSTICK TO OPERATE IMPLEMENTS

Mid-mounted front remote valves are controlled by a joystick which operates both front- and mid-mount implements.



INTUITIVE CONTROLS FOR SIMPLE OPERATION

Fingertip controls conveniently integrated into the right-hand console provide easy and intuitive control of electronically-operated rear hitch. The sensors located on the three-point linkage allow optimum adjustment of hitch sensitivity for maximum efficiency of the tractor-implement combination.

The ROPS version of the X4F and GE tractors feature an innovative design which combines beauty and functionality. The sleek, dynamic lines of the hood and the rounded profile of the fenders allow this tractor to move easily under low branches and through narrow rows.

Spacious, comfortable, and safe, the driving position ensures exceptional all-round visibility, thereby maximizing productivity.



FOCUS ON THE OPERATOR: MORE COMFORT AND LESS FATIGUE

The driving position has been designed to allow ease of movement and to reduce operator fatigue during long working hours in the field. The spacious platform is iso-mounted to absorb impacts of rough terrain and allows easy access to the driving position. The optimum distance between the driver's seat and the steering wheel and the ergonomic arrangement of all controls make for maximum comfort and ease of operation.

McCormick X4 GE, for those who want to keep a low profile

The driving position of X4 GE (low profile) is ideal for low orchards: perfect for moving under low-hanging branches.

HIGHLIGHTS

- › Spacious and comfortable iso-mounted platform
- › Ease of access to the driving position
- › Excellent front and rear visibility
- › Ergonomically-arranged controls
- › Axles equipped with central drive, differential lock and hydraulic 4WD engagement



UP TO 55° STEERING ANGLE

Optimization of the engine compartment along with 16 or 18 inch tires allow the tightest steering angle to be obtained, making for excellent maneuverability in tight quarters.

FUNCTIONAL FOLDING ROPS

The ROPS is equipped with two pneumatic cylinders to aid raising and lowering of the frame.



HIGHLIGHTS

- › Transmissions: Standard 16x16 speeds with creeper, or optional 15x15 and 40x40 transmissions available.
- › De-Clutch control and Power Shuttle to shift through gears and change from forward to reverse without using the clutch pedal option available

SPECIALIZED TRANSMISSION TO BE ONE STEP AHEAD



The ROPS version of the X4F and GE features as standard a 16x16 speed transmission with creeper gear and synchronized mechanical shuttle capable of 25mph (40kph). A 15x15 speed transmission with five gears and three ranges is available with reverse power shuttle. This five gear transmission can be optionally combined with 2-speed power shift and creeper reduction gears to obtain 40 forward and 40 reverse speeds.



TWO-SPEED PTO WITH MODULATED ENGAGEMENT

The PTO offers two speeds: 540 and 1000 rpm. An electrohydraulic push button control, standard on all models, enables smooth and modulated engagement of the PTO, ensuring a soft start-up of the implement.

HYDRAULIC SYSTEM WITH DOUBLE PUMP

HIGHLIGHTS

- › Double pump with 13.2+7.4 gpm (50+28 l/min) flow rate standard
- › Two rear spool valves standard; float, flow divider, and kick out options available.
- › Rear hitch lift capacity 5,732 lbs (2600 kg).
- › PTO with two speeds: 540 and 1000 rpm. Groundspeed PTO standard.

The ROPS models feature as standard a hydraulic system with a double pump that supplies 13.2 gpm (50 l/min) to the rear hitch and remotes and 7.4 gpm (28 l/min) to the steering system. 2 rear-mounted valves, 1 standard and 1 float, come standard with the X4F and GE tractors. Available as an option with 2 spool valves are S/D acting (1 motor with flow divider + 1 float) or D/E (1 motor with flow diverter + 1 kick out). A flow selector is also available as an option with 2 front splitting pipes.



TWO REAR REMOTE VALVES

The two rear remotes valves are mechanically controlled and feature double outlets. The optional front splitting pipes with flow selector allow the use of front and rear couplers.



SUPERIOR OPERATING COMFORT

The rear hitch is mechanically operated via easy-to-use controls ergonomically integrated into the right-hand console.



Mechanical hitch for power and versatility

To increase the versatility of the X4F and GE ROPS tractors, a Category 2 rear hitch capable of lifting up to 5,732 lbs (2600 kg) comes standard with fixed ball ends and mechanical top link. Quick attach hook option available on X4F models.

SPECIFICATIONS: ROPS

Tractor Model		X4.90F/GE ROPS	X4.100F/GE ROPS	X4.110F/GE ROPS	X4.120F/GE ROPS
Engine					
Max. ISO Engine HP @ 2200 RPM	HP (kW)	90 / 66	95 / 70	102 / 75	112 / 82
Max. ISO PTO HP @ 2200 RPM*	HP (kW)	79 / 58	83 / 63	95 / 70	105 / 77
Max. Engine Torque @ 1600 RPM	lb ft (Nm)	378	400	410	420
Engine Type	Duetz AG TCD engine, 2.9L, 4-cylinder, Tier 5 with DOC (No DPF with regeneration)				
Engine Size	2.9 Liter, 4-cylinder				
Fuel Capacity	gal (liter)	17.17 (65)			
Drive Train					
Standard Transmission	Transmission 16 x 16 with 4 ranges (Incl. Creeper), 4 gears - 25 mph (40 Km/h)				
Optional Transmission (1)	Transmission 32 x 32 with powershift and creeper - 40 Km/h				
Optional Transmission (2)	Transmission 48 x 16 with powershuttle and 3 speed powershift HML				
Clutch	Independent dual dry clutch standard; multi-disc wet clutch standard with hydraulic shuttle				
Brakes	Heavy duty wet multi-disc disc brakes				
Differential Lock	Limited slip				
4wd Front Axle	Rigid front axle				
Tire Type	Radial tires standard				
Hydraulics, 3-point Hitch, PTO					
Standard Hydraulic Pump	gpm (lpm)	Open center hydraulic system: 13.2 gpm (50 L/min to the implement + 7.4 gpm (28 L/m) for steering			
Standard Rear Remote Valves	2 spool valves double acting (1 standard + 1 float)				
Standard Rear 3-point Hitch Type	3 Point linkage category 2 with fixed ball ends, bent lower arms. 3 PT hitch lift capacity 5,732 (2,600 Kg)				
Rear 3-point Lift Capacity	lb (kg)	5,952.48 (2,700)			
Rear PTO	PTO 2 speeds, 540/1000 rpm w/additional 21 spline 1" 3/8				
Operator's Area					
ROPS Area	Silent bocks platform suspensions with 2 posts folding safety frame				
Seat and Front Dash	Cloth seat, air suspension; tilt and telescopic steering wheel				
Weights and Dimensions					
Wheelbase	in (mm)	84.25 (2,140)			
Height Over ROPS	in (mm)	F Model: GE Model:			
Minimum overall width	in(mm)	F Model: GE Model:			
Base Weight without ballast	lb (kg)	F Model: GE Model:			

*Manufacturer's estimate. +/- 5% tolerance. Max PTO HP at 1000 RPM shaft rated speed

Tractor Model		X4.90F/V CAB	X4.100/V CAB	X4.110F/V CAB	X4.120F/V CAB
Engine					
Max. ISO Engine HP @ 2200 RPM	HP (kW)	90 / 66	95 / 70	102 / 75	112 / 82
Max. ISO Engine HP @ 2200 RPM*	HP (kW)	79 / 58	86 / 63	95 / 70	105 / 77
Max. Engine Torque @ 1600 RPM	lb ft (Nm)	378	400	410	420
Engine Type	DUETZ AG TCD engine, 2.9 L, 4-cylinder, Tier 5 with DOC (No DPF with regeneration)				
Engine Size	2.9 Liter, 4-cylinder				
Fuel Capacity	gal (liter)	F 21.14 (80) / V 15.85 (60)			
Drive Train					
Standard Transmission	Transmission 16 x 16 with 4 ranges (Inc. Creeper), 4 gears - 25 mph (40 Km/h)				
Optional Transmission (1)	Transmission 32 x 32 with powershift and creeper - 40 km/h				
Optional Transmission (2)	Transmission 48 x 16 with power shuttle and 3 speed powershift HML				
Clutch	Independent dual dry clutch standard; multi-disc wet clutch standard with hydraulic shuttle				
Brakes	Heavy duty wet multi-disc disc brakes				
Differential Lock	Limited slip				
4wd Front Axle	Rigid front axle				
Tire Type	Radial tires standard				
Hydraulics, 3-point Hitch, PTO					
Standard Hydraulic Pump	gpm (lpm)	Open center hydraulic system: 13.2 gpm (50 L/min to the implement + 7.4 gpm (28 L/min) for steering			
Hydraulic Flow Rate hitch + steering	15.3 + 7.92 (58 +30)				
Rear Remote Valves	2 spool valves double acting (1 standard + 1 float)				
Standard Rear 3-point Hitch Type	3 point linkage category 2 with fixed ball ends, bend lower arms. 3 PT hitch lift capacity 5,732 lbs (2,600 Kg)				
Optional Rear 3-point Hitch Type	Category 2 with quick attach hooks; electronic lift control option (<i>F Series Only</i>)				
Rear 3-point Lift Capacity	lb (kg)	5,952.48 (2,700)			
Rear PTO	PTO 2 speeds, 540/1000 rpm w/additional 21 spline 1" 3/8				
Operator's Area					
Cab	high-visibility 4-post monocoque cab with flat floor and opening front & rear windows				
Seat and Front Dash	Cloth seat, air suspension; tilt and telescopic steering wheel				
Weights and Dimensions					
Wheelbase	in (mm)	F Model: 84.25 (2,140) V Model: 86.22 (2,190)			
Minimum Width	in (mm)	F Model: 52.7 (1,340) V Model: 39.37 (1,000)			
Minimum Height Over Cab	in (mm)	75.98 (1,930)			
Base Weight without ballast	lb (kg)	6,393.40 (2,900)			

*Manufacturer's estimate. +/- 5% tolerance. Max PTO HP at 1000 RPM shaft rated speed



McCormick North America
www.McCormickNA.com

updated: March 2023

