



COMMERCIAL
MOWERS





IMPROVING LIFE & LAWCARE

In 1964, Hustler Turf introduced the world's first twin-lever zero-turn lawn mower. Today, the twin-lever design created by Hustler is used by most zero-turn manufacturers. With a jump on the competition, Hustler quickly began improving the original design by implementing a rigorous R&D program to engineer, test, and push the envelope on what was possible with a zero-turn mower for the commercial market.

Over the years, Hustler's commercial lineup has evolved into the most complete lineup in the industry. From sit-downs to stand-ons to walk-behinds, and deck sizes ranging from 36-inches to 104-inches, Hustler Turf is a one-stop shop for mowing professionals. Additionally, Hustler has three industry exclusives not offered by any other brand: the HyperDrive® hydraulic system, a 104-inch zero-turn, and an 88-inch stand-on model.



THE HUSTLER® ADVANTAGE

SMOOTHTRAK™ STEERING

Precision control to help trim and maneuver easily around obstacles. This steering system has been developed over decades of experience. Many have tried to reverse-engineer this design only to learn that it's not one component that makes it the smoothest in the industry.



INTEGRATED PARK BRAKE

Hustler was the first to integrate the parking brake into the twin-lever design. This design was patented for years and continues to be a great safety feature for operators.



HEAVY-DUTY DECKS

Our fabricated welded-steel decks are designed to handle the harshest conditions. We use heavy-gauge steel and reinforced impact areas that prolong the life of the deck.



TOUGH FRAMES

Fabricated welded-steel frames, over-engineered front axles, and thick front forks with heavy-duty caster yokes ensure your mower withstands whatever you can throw at it. Our frames are tested for thousands of hours on grass and concrete test tracks with inclines and embankments.



SIMPLE DESIGN

Who wants something you can't work on yourself? More engineering doesn't always mean more parts or more complexity. Quite the opposite. We engineer our mowers to have fewer parts and more access points making them efficient and easy to maintain.



PROFESSIONAL CUT QUALITY

Our decks are not only durable, they're engineered to provide the cleanest and most professional looking cut. This comes from decades of learning how to manipulate the airflow inside the deck, creating a vacuum that lifts the grass when it's cut. The result is an even cut and defined stripes.



COMMERCIAL MOWERS

OVERVIEW

MID-MOUNT MOWERS

STAND-ON

WALKBEHIND

FASTRAK®	SURFER PRO	TRIMSTAR®
FASTRAK® SDX	SUPER S®	
X-ONE®	SUPER SF	
SUPER Z®	SUPER 88	
HYPERDRIVE®		
DIESEL Z		
SUPER 104		

OTHER PRODUCTS AVAILABLE

RESIDENTIAL MOWERS

GENERATORS AND INVERTERS

PRESSURE WASHERS



HYPERDRIVE SYSTEM

Increase the life and performance of your mower with Hustler's exclusive HyperDrive system, the largest, most durable drive system in the industry. With temperature regulation and heavy-duty components, the HyperDrive system is only running at about 30% of its peak capacity which is why we offer an industry-leading 5-year / 3,000-hour warranty on the hydraulic system. By not pushing its components to peak capacity 10 hours-a-day 7 days-a-week, the HyperDrive allows professionals to get more done and more out of their mower.



9" Fan & High Capacity Oil Cooler with Hot Oil Shuttle



Large Oil Reservoir

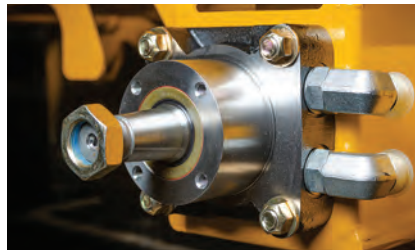

Heavy-Duty Parker TG280 Wheel Motors



Industrial-Grade Slipper Piston Pumps - pumps of this size are not found on other zero-turn mowers.

Available on the following mowers:

HYPERDRIVE
SUPER 104

**INDUSTRY'S
BEST WARRANTY**



VX DECK TECHNOLOGY

The Hustler VX deck is engineered for extreme vacuum. The deck draws grass and leaves up into the mower blades more efficiently resulting in a consistent cut for all grass types including thin dry grass.

Available on the following mowers:

X-ONE
SUPER S
SUPER SF

1 Front Wall to Blade Distance
Opened to provide better grass throughput and wider and more even clipping dispersal.

2 Internal Front Wall Height
Reduced to allow grass to better stand back up.

3 Full Width Air Channel
Open across the entire front deck, allows crossflow in front of cutting chamber to improve vacuum across the width of the deck.

4 Anti-scalp Wheels
Located outside the deck to keep the air channel unobstructed.

5 "Cut-off" Baffle
Increases throughput and balances airflow.

6 "Sharp" Wrapper Intersections
Reduces volume of air flow across the back of the deck.

7 Extra-high Sail Blades
Creates better lift.

8 Front of the Deck
11 ga. bull nose/ramp.



9 Blade Bolt Protectors
Guards the bolts from being sheared off from uneven ground or hard debris.

10 7 ga. Deckplate with 7 ga. Stamped Spindle Mounts
Provides increased strength and longer life in sandy conditions.

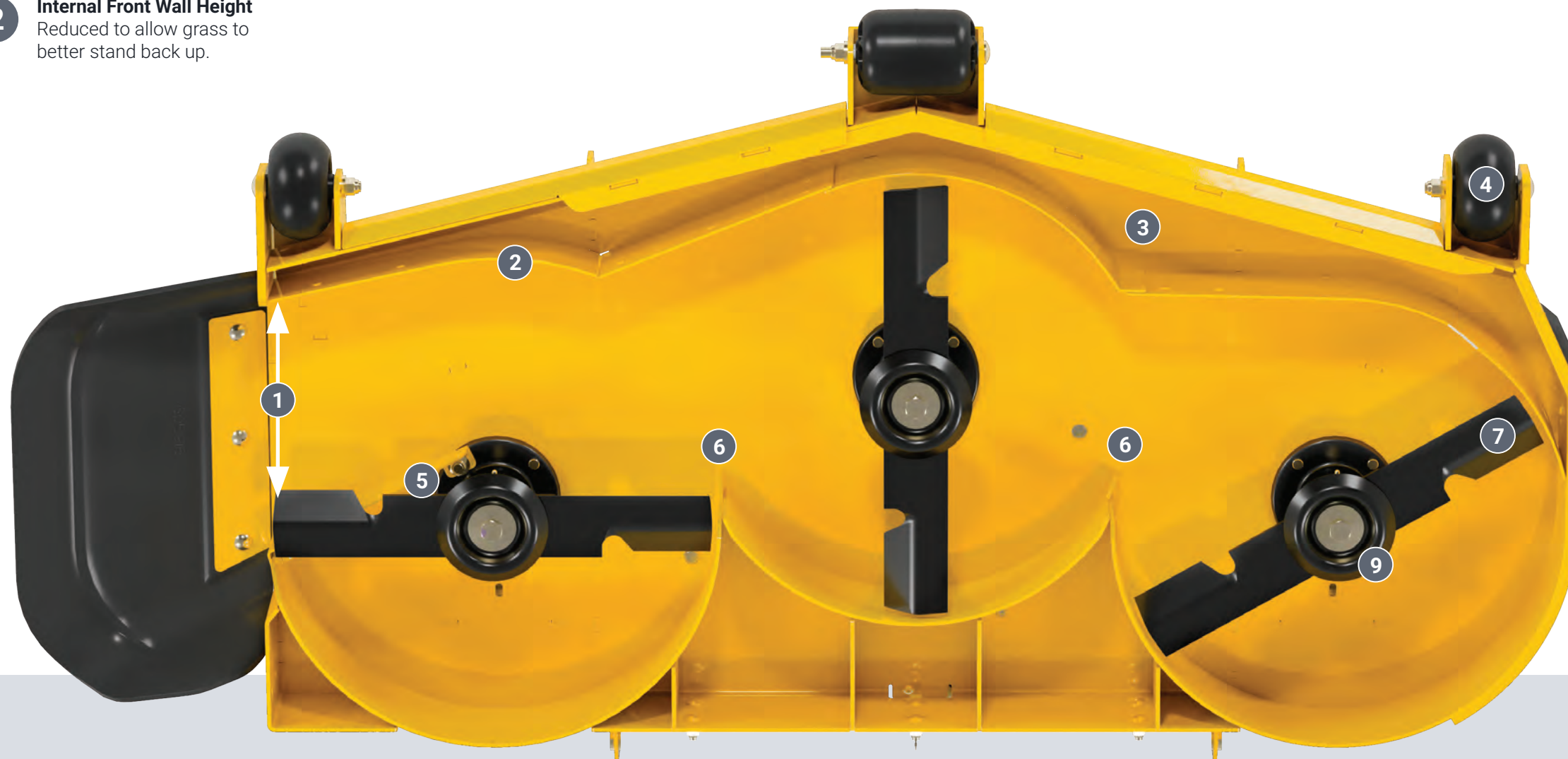

VX4® DECK TECHNOLOGY

The VX4 Deck combines four performance features to give you the quickest, cleanest, and most professional looking cut: Versatility, Velocity, Vacuum, and Volume. The combination allows professionals to move more grass through the deck more efficiently and consistently.

Available on the following mowers:

Super Z
HyperDrive
Diesel Z

DECK FEATURES

- 1 Formed Discharge Stiffener**
Added rigidity to prevent movement to the discharge opening.
- 2 Deckplate Reinforcement**
7 ga. steel supports along the top of the deck provides continuous support from front to back to keep the deck from bending.
- 3 Stamped Deck Doublers**
Stamped 7 ga. steel around the spindle mount areas creates a $\frac{3}{8}$ " total thickness protecting the spindle and adding strength to the deck.

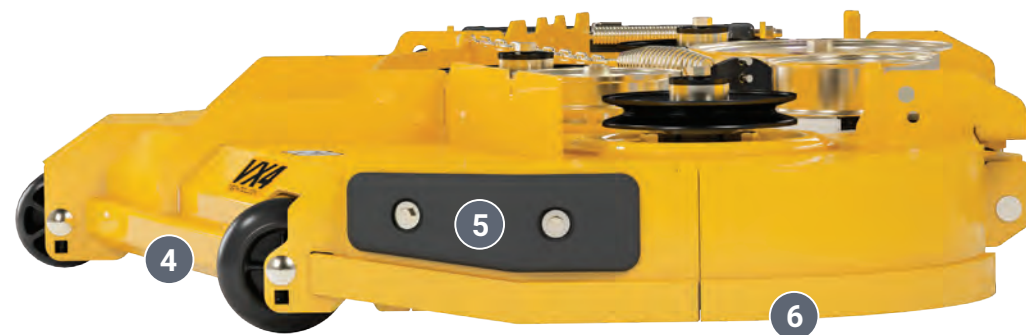

- 4 Formed Bump Bar**
Angled contact surface formed and engineered to protect the deck by deflecting any impact.
- 5 Wear Guard**
Poly replaceable wear plate protects deck trim edge and obstacles from damage.
- 6 Deck Guards**
 $\frac{3}{8}$ " thick guard protects the integrity of the deck from side impacts.

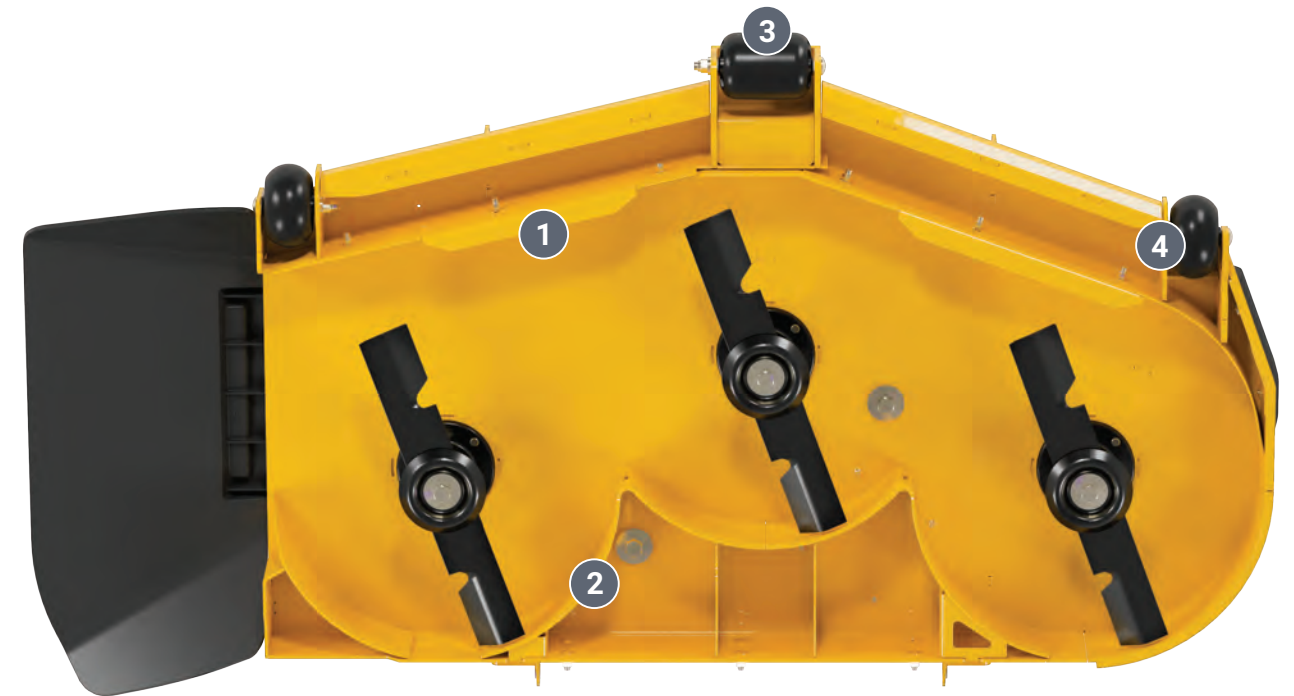

UNDERSIDE OF DECK FEATURES

- 1 Adjustable Front Baffle**
Optimize the deck according to mowing season and grass type for best cut.
- 2 Deck Wrappers**
Heavy duty 7 ga. steel fortify deckplate.
- 3 Front Anti-Scalp Wheel**
Commercial anti-scalp wheels with internal bushing protects turf from scalping damage on uneven terrain.
- 4 Heavy Gauge Mounts**
Anti-scalp wheels protected by $\frac{3}{8}$ " heavy gauge integrated steel mounting plates.

SPINDLE IMPROVEMENTS

- Debris Shield**
Protects the top bearing from water, dirt, and debris.
- Relief Fitting**
Protects seals from overpressure when filling with grease.
- Ductile Cast Iron Housing**
Corrosion resistant and high tensile strength provide extra protection for spindles.
- Grease Zerk**
Easy access to grease the spindles.
- Blade Bolt Protectors**
Guards the bolts from being sheared off from uneven ground or hard debris.

FASTRAK

Engine	Decks Sizes Available
22HP - Kawasaki® FT691	48", 48" RD, 54", 54" RD
24HP - Kawasaki FT730	60"
27HP - KOHLER® 7500 EFI	54", 60"

RD = Rear Discharge

✓ 4yr / 750hr limited warranty



Standard Dual USB Port



UPGRADES FOUND ON THE

FASTRAK SDX

Engine	Decks Sizes Available
22HP - Kawasaki FX691	48", 54"
23.5HP - Kawasaki FX730	60"

- ✓ **Extra High-Back Suspension Seat**
Higher backrest and more bolstered back cushion
- ✓ **Kawasaki® FX Engine**
Full commercial remote canister air cleaner
- ✓ **Larger Transmissions**
Hydro-Gear ZT-3400™
- ✓ **More Warranty Coverage**
4yr/1000hr compared to 4yr/750hr



Premium Suspension Seat
High-back seat with suspension to shield the operator from bumps and EVC cushion to take pressure off tail bone and lower back.



Commercial-Grade Kawasaki® FT Engine
With Vortical Air Filtration. Cleans debris to help extend engine life.



Dual Roto-Molded Fuel Tanks
8.5 gallon fuel capacity and dual fuel gauges.

FASTRAK SERIES

FASTRAK & FASTRAK SDX SHARED FEATURES

1 Magnetic Top Pin Deck Lift System
Adjust the deck height between 1.5" -4.5" with your foot.

2 SmoothTrak™ Steering
Precision control to help trim and maneuver easily around obstacles. Other brands have sensitive steering levers causing sudden jerky movements.

3 Heavy-Duty Deck Hangers
Commercial-grade, cast deck hangers for improved durability.



4 Front and Rear Tie Downs
1.5" x 3" tubular steel fabricated frame with front and rear tie downs.

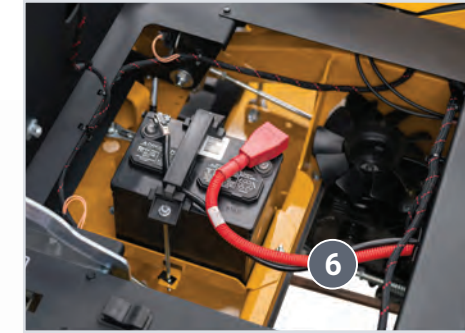

5 Easy Serviceability
Flip-up seat pan, removable floor pan, and toolless removable pulley covers make maintenance easy and simple.

6 Less Clutter Under Seat
Provides better airflow keeping transmissions cooler.

7 Transmissions
Serviceable commercial-grade Hydro-Gear® ZT-3200™

8 Welded Steel Deck
Durable 10 ga. welded fabricated steel.

9 BigBite™ Tires
Enhanced traction designed not to tear up turf. We worked directly with the tire manufacturer on this product.

FasTrak model pictured above.

X-ONE

X-ONE

Engine	Decks Sizes Available
23.5HP - Kawasaki FX730	54" RD, 60", 60" RD
24HP - Kawasaki FT730	60"
25HP - KOHLER Command Pro	52", 60"
27HP - Kawasaki FX850	52", 60", 72"
29.5HP - Kawasaki FX850 EFI	60", 72"

RD = Rear Discharge

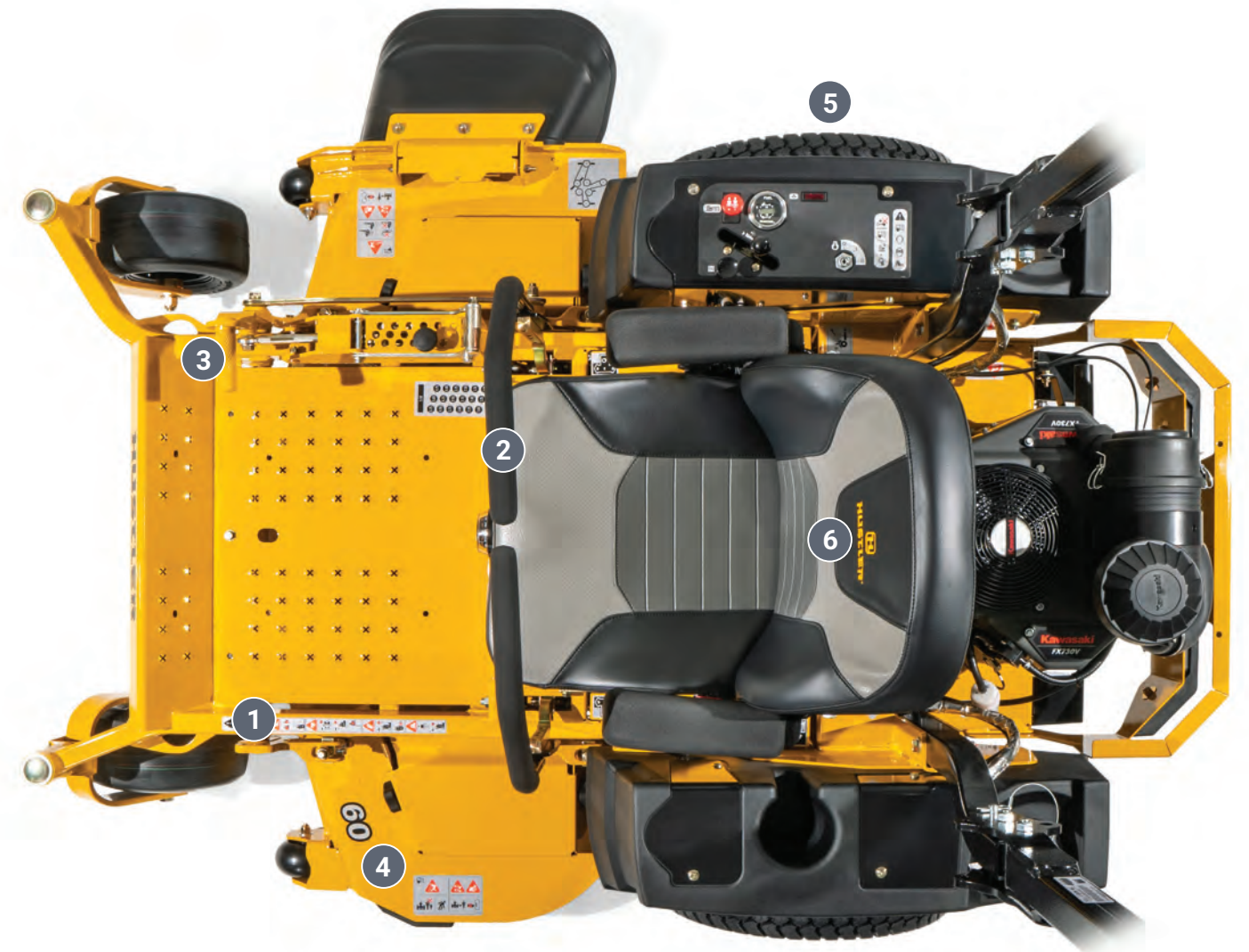

✓ 5yr / 1200hr limited warranty
(First 2 years no hour limit)



VX Deck
Engineered for extreme vacuum enhancing performance and cut quality.



I3M Suspension Seat
High-back seat with adjustable armrests and 3-inch travel range.



Commercial-Grade Engines
Kawasaki® FX, FT and KOHLER Command Pro Engine options backed by 3-year warranties.

- 1 Fabricated Frame for Durability**
1.5" x 3.0" steel frame making it one of the toughest and most durable in its class.
- 2 SmoothTrak™ Steering**
Precision control to help trim and maneuver easily around obstacles. Other brands have sensitive steering levers causing sudden jerky movements.
- 3 Foot Operated Deck Lift**
Easily adjust the deck height between 1" - 5.5" with your foot.
- 4 VX Deck**
Fabricated 7 ga. steel engineered for extreme vacuum enhancing performance and cut quality.
- 5 Commercial-Grade Torque**
Driven by Parker unitized transmissions.
- 6 I3M Seat**
High-back seat with adjustable armrests and 3-inch suspension travel range.

SUPER Z

SUPER Z

Engine	Decks Sizes Available
27HP - Kawasaki FX850	54", 60", 60" RD, 72" RD
35HP - Kawasaki FX1000	60", 66", 72"
38.5HP - Kawasaki FX1000 EFI	60", 72"
36HP - Vanguard BigBlock™	60", 72"

RD = Rear Discharge



✓ 5yr / 1200hr limited warranty
(First 2 years no hour limit)

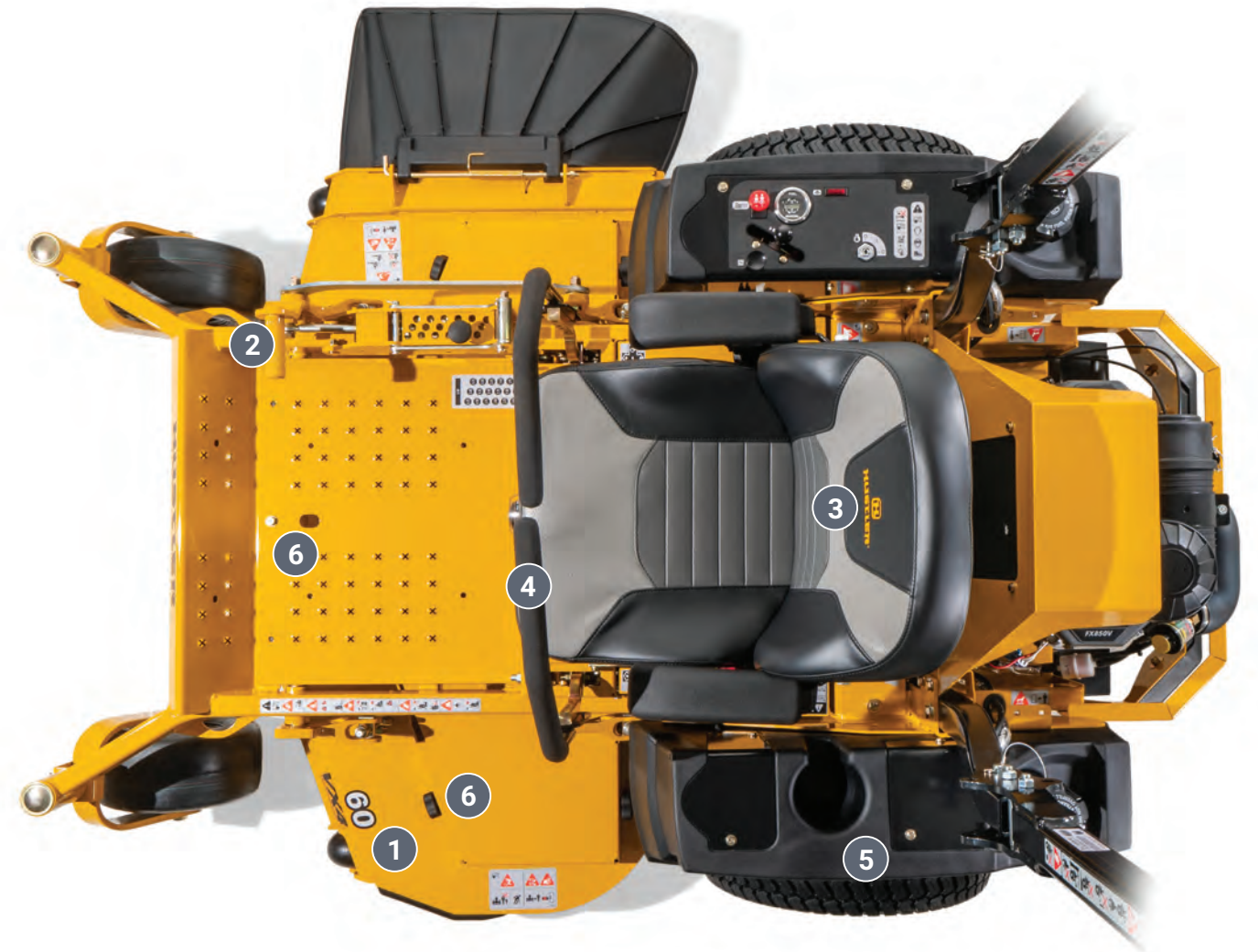

Commercial-Grade Torque
Hydro-Gear 21cc PY pumps
and Parker TG wheel motors.



Heavy-Duty Hydraulics
with 3 gal. oil reservoir, oil cooler
w/ fan & hot oil shuttle.



**Kawasaki FX & Vanguard
Big Block Engines**
FX1000 EFI also available.

- 1 VX4® Deck**
Fabricated 7 ga. steel deck
engineered to move more
grass at high speed while
maintaining cut-quality.
- 2 Foot Operated Deck Lift**
Easily adjust the deck
height between 1" - 5.5"
with your foot.
- 3 I3M Suspension Seat**
High-back seat with
adjustable armrests and
3-inch travel range.
- 4 SmoothTrak™ Steering**
Precision control to help trim
and maneuver easily around
obstacles. Other brands have
sensitive steering levers causing
sudden jerky movements.
- 5 Large Fuel Capacity**
Large 11.7 US gal. fuel
tank for all-day mowing.
- 6 Easy Serviceability**
Flip-up seat pan, removable
floor pan, and vented pulley
covers for easy and
simple maintenance.

HYPERDRIVE

HUSTLER EXCLUSIVE 

HYPERDRIVE

Engine	Decks Sizes Available
40HP - Vanguard BigBlock™ EFI	60", 66", 72"
35HP - Kawasaki FX1000	60", 60 RD", 72", 72" RD
40HP - Vanguard BigBlock EFI w/ Oil Guard	60", 72"
38.5HP - Kawasaki FX1000 EFI	60", 72"

RD = Rear Discharge



INDUSTRY'S
BEST WARRANTY

5 YEAR | **3000** HOUR
PUMPS
AND
MOTORS

✓ 5yr / 1200hr limited warranty
(First 2 years no hour limit)



HyperDrive® Hydro System
Features industrial-grade pumps and motors to handle tough jobs and long days.



Optional Vanguard® Big Block™ Engine w/ Oil Guard
500 hour oil change.



Industrial-Grade Slipper Piston Pumps
Pumps of this size are not found on other zero-turn mowers.

- 1 SmoothTrak™ Steering**
Precision control to help trim and maneuver easily around obstacles. Other brands have sensitive steering levers causing sudden jerky movements.
- 2 Foot Operated Deck Lift**
Easily adjust the deck height between 1" - 5.5" with your foot.
- 3 I3M Suspension Seat**
High-back seat with adjustable armrests and 3-inch travel range.
- 4 Commercial-grade Torque**
Danfoss DDC-20 pumps and Parker TG wheel motors.
- 5 VX4® Deck**
Fabricated 7 ga. steel deck engineered to move more grass at high speed while maintaining cut-quality.
- 6 Easy Serviceability**
Flip-up seat pan, removable floor pan, and vented pulley covers for easy and simple maintenance.

DIESEL Z

Engine	Decks Sizes Available
25HP - Perkins	60" RD, 60", 72", 72" RD

RD = Rear Discharge



✓ 5yr / 1200hr limited warranty
(First 2 years no hour limit)



Service Access
Removable back cover for maintenance access.



I3M Suspension Seat
High-back seat with adjustable armrests and 3-inch travel range.



Patented Belt Drive System
Further extends the life of the machine.

DIESEL Z

- 1 Formed Bump Bar**
Angled contact surface formed and engineered to protect the deck by deflecting any impact.
- 2 Reinforced Edge**
1.5" x .375" steel bar.
- 3 14.4 US Gallon Fuel Capacity**
- 4 VX4® Deck**
Fabricated 7 ga. steel deck engineered to move more grass at high speed while maintaining cut-quality.
- 5 Top Access**
Top hatch opens for access to service points.
- 6 Filter Access**
Easy access to slide out filter.

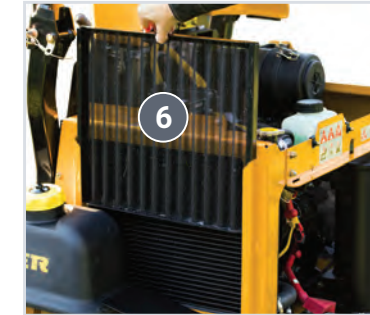

SUPER 104

HUSTLER EXCLUSIVE ★

Engine	Decks Sizes Available
35HP - Kawasaki FX1000	104" RD
40HP - Vanguard BigBlock EFI w/ Oil Guard	104" RD
38.5HP - Kawasaki FX1000 EFI	104" RD

RD = Rear Discharge



✓ 5yr / 1200hr limited warranty
(First 2 years no hour limit)

» Mows a football field
in under 10 minutes.



HyperDrive® Hydro System
Features industrial-grade pumps and motors to handle tough jobs and long days.



104" Width of Cut
Widest and most productive commercial zero-turn available.



80" Transport Width
Fits most trailers making it easy to transport from job-to-job.

SUPER 104

1 HyperDrive® Hydro System
Features industrial-grade pumps and motors to handle tough jobs and long days.

2 SmoothTrak™ Steering
Precision control to help trim and maneuver easily around obstacles. Other brands have sensitive steering levers causing sudden jerky movements.

3 Hydraulic Deck Height Adjustment
Raising and lowering your cutting height has never been easier.

4 I3M Suspension Seat
High-back seat with adjustable armrests and 3-inch travel range.

5 Commercial-Grade Engines
Vanguard Big Block™ EFI with Oil Guard, Kawasaki FX1000, and FX1000 EFI engine options.

6 Hydraulic Wings
Easily raise and lower wings for transporting.



80" Transport Width
Fits most trailers making it easy to transport from job-to-job.

104" Width of Cut
Widest and most productive commercial zero-turn available

SURFER PRO

Engine	Decks Sizes Available
15HP - Kawasaki FS541	34", 48"

- ✓ 3yr / 300hr residential limited warranty or 2yr / 300hr commercial limited warranty



Kawasaki FS Engine
15hp Commercial FS541
V-Twin Engine.



Fabricated Deck
Heavy duty construction.



Ideal for Commercial Contractors and Homeowners
For tight spaces and fenced backyards with gates.

SURFER PRO

- 1 Semi Pneumatic Front Tires
11" front tires.
- 2 34" & 48" Decks
Fabricated steel decks for durability.
- 9 2 Gallon Fuel Capacity



- 3 18" Drive Tires
Provides stability and traction.
- 4 Small Footprint
For storage and trailering.
- 5 Park Brake
Hand operated lever to set the park brake.
- 6 Kawasaki FS541 Engine
15hp
- 7 Hydro-Gear ZT-1800®
Transmissions
- 8 Cut Height Adjustment
Hand operated lever and pin to easily adjust deck/cutting height.

SUPER S

Engine	Decks Sizes Available
15HP - Kawasaki FS541	36"
19HP - Kawasaki FX600	36"
22HP - Kawasaki FX691	48"
22HP - Kawasaki FT691	52"
27HP - Kawasaki FX850	52", 60"
29.5HP - Kawasaki FX850 EFI	52", 60"



- ✓ 5yr / 1200hr limited warranty (First 2 years no hour limit)



Compact Stance
Perfect for tight spaces and trailering from job-to-job.



VX Deck
Fabricated 7 ga. steel engineered for extreme vacuum enhancing performance and cut quality.



SmoothTrak™ Steering
Precision control to help trim and maneuver easily around obstacles.

SUPER S

- 1 **Pulley Covers**
Toolless removable pulley covers for easy maintenance.

- 2 **Park Brake**
Hand operated lever to set the park brake.

- 7 **24" Rear Drive Tires**
For superior traction. (48", 52", 60")



- 3 **Cut Height Adjustment**
Hand operated lever and pin to adjust deck/cutting height.

- 5 **Adjustable Foot Platform**
Spring loaded suspension platform for all-day comfort.

- 4 **Wide Operator Platform**
For all-day mowing comfort and operator stability.

- 6 **Service Friendly Design**
Designed to make maintenance and service fast and easy.

- 8 **Adjustable Speed Controls**
Allows you to go at your own pace for added control. Also helps with training new operators.

SUPER SF

Engine	Decks Sizes Available
38.5HP - Kawasaki FX1000 EFI	60", 72"
40HP - Vanguard BigBlock EFI w/ Oil Guard	60", 72"

RD = Rear Discharge



✓ 5yr / 1200hr limited warranty
(First 2 years no hour limit)

» Up to 15mph top speed



Strong Hydraulics
Hydro-Gear 21cc pumps and Parker TG wheel motors



VX Deck
Fabricated 7 ga. steel engineered for extreme vacuum enhancing performance and cut quality.



Dual Fuel Tanks
13.9" gal fuel capacity

1 Semi Pneumatic Front Tires
13" front tires.

2 60" and 72" VX Deck
7 ga. deckplate with 7 ga. stamped spindle mounts and 11 ga. bull nose leading edge.

7 Large Rear Tires
26" x 12 rear tires are larger than any other unit on the market.



3 Electric Actuator Deck Lift
Easily adjust your cutting height from 2.0" to 5.5".

5 Kawasaki FX EFI and Vanguard EFI Oil Guard Engine
38.5 and 40 hp options.

4 Hydro Oil Cooler
8" fan and 6-quart reservoir capacity.

6 Service Friendly Design
Designed to make maintenance and service fast and easy.

8 Speed Control Bar Adjustment
Up to 15 mph with reduced speed up to 10 mph.

SUPER 88

HUSTLER EXCLUSIVE ★

Engine	Decks Sizes Available
36HP - Vanguard BigBlock	88" RD
37HP - Vanguard BigBlock EFI w/ Oil Guard	88" RD

RD = Rear Discharge

- ✓ 5yr / 1200hr limited warranty
(First 2 years no hour limit)



Designed to Flex with the Landscape
Contours with the mowing surface providing improved cut quality and scalping prevention.



76" Transport Width
Fits most trailers making it easy to transport from job-to-job.



Reinforced Impact Areas
1/4" thick steel wrapper added to the impact areas of the deck.

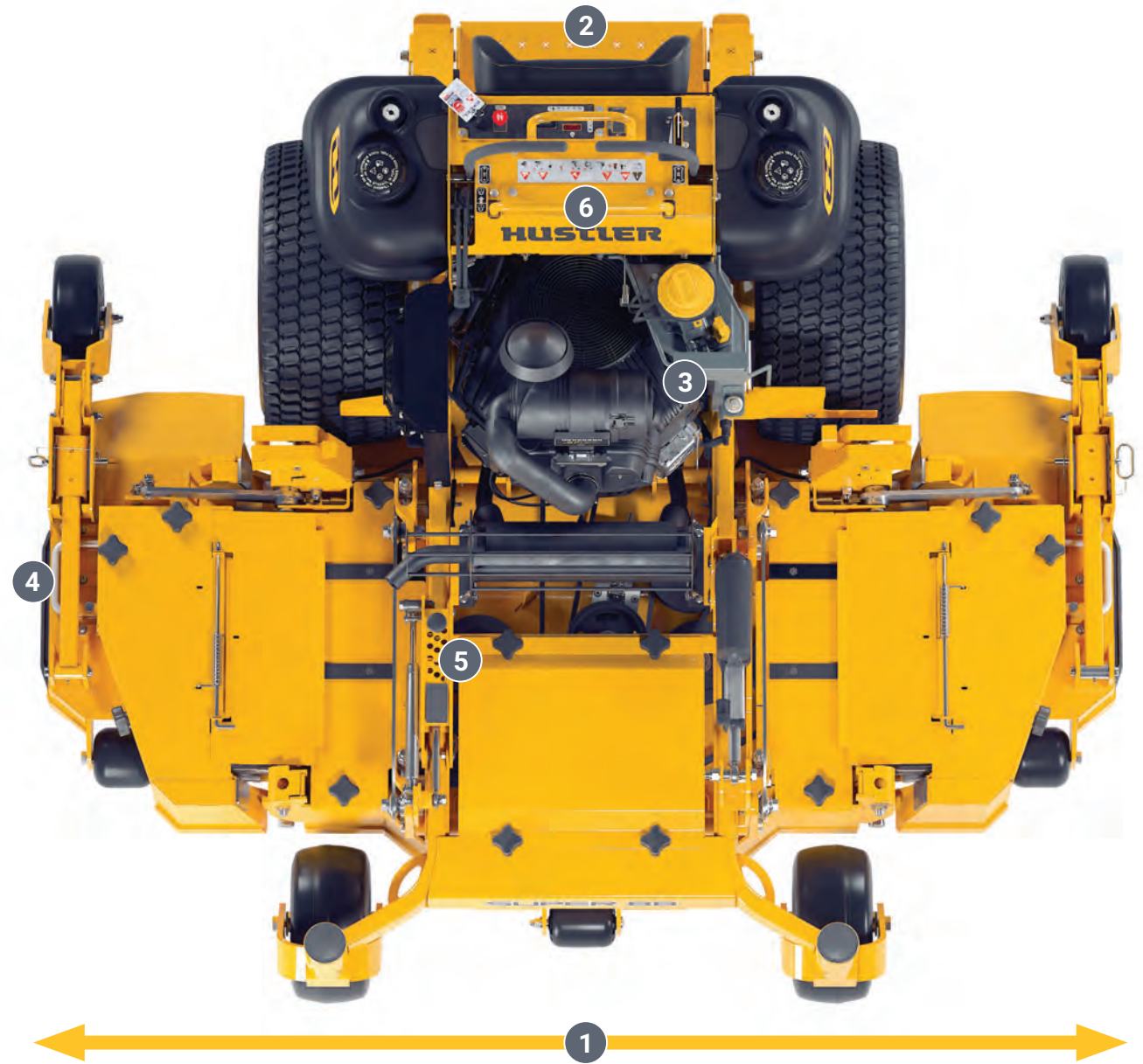

1 88" Width of Cut
The cut quality of a 54" deck plus the productivity of an 88" deck.

2 Adjustable Foot Platform
Spring loaded suspension platform for all-day comfort.

3 Vanguard Big Block™ Power
With Oil Guard option allowing for 500 hours between changes.

4 Transport Position
The wing decks are manually lifted using pull-out lift assist handles and gas spring assist.

5 Cut Height Adjustment
The center deck uses electric actuated height adjustment. The height of the wing decks are adjusted manually.

6 Adjustable Speed Controls
Allows you to go at your own pace for added control. Also helps with training new operators.

SUPER 88

TRIMSTAR

Engine	Decks Sizes Available
15HP - Kawasaki FS541 (Electric Start)	36"
18.5HP - Kawasaki FS600 (Electric Start)	48"
22HP - Kawasaki FS651 (Electric Start)	54"
23HP - Kawasaki FS691 (Electric Start)	60"

- ✓ 5yr / 1200hr limited warranty
(First 2 years no hour limit)



Welded Steel Deck
Durable 10 ga. plus 11 ga. reinforced steel with 11 ga. formed channel rolled edge. (36 in. deck is 7 ga. plus 7 ga reinforced steel)



Dual Hydro System
Hydro-Gear ZT-2800® transmissions provide heavy-duty traction and performance.



Compact Stance
Perfect for tight spaces and for trailering from job-to-job.

TRIMSTAR



- 1 Ergo-Designed Controls**
H-Bar® steering is the easiest-to-use walk-behind system in the industry, reducing operator fatigue.
- 2 SmoothTrak™ Steering**
Precision control to help trim and maneuver easily around obstacles. Other brands have sensitive steering levers causing sudden jerky movements.
- 3 3.4 US Gallon Fuel Capacity**
- 4 Deck Lift**
Easy-to-operate deck lift makes deck height adjustment a breeze.
- 5 Service Friendly Design**
Designed to make maintenance and service simple and easy.
- 6 20" Drive Tires**

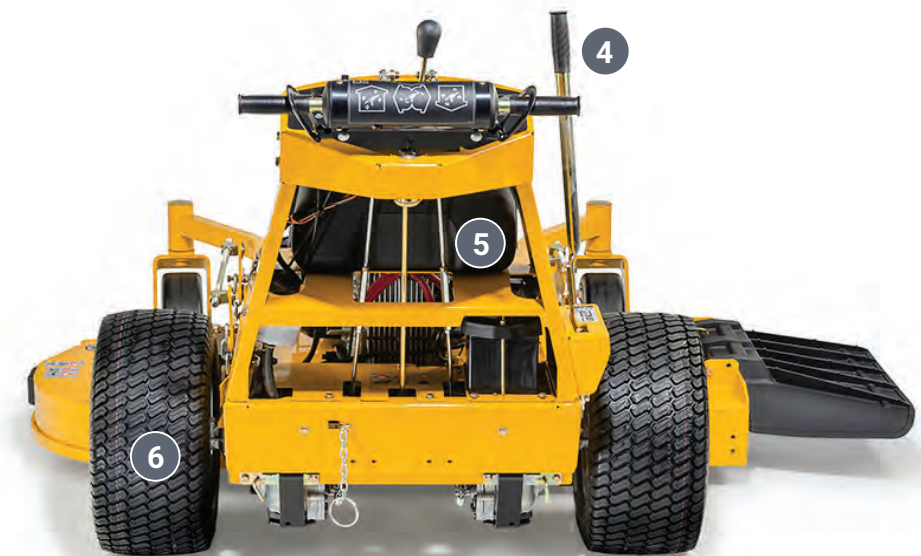



2-BAG POWERED BAGGER

Bagger has a 7.2-bushel capacity. Available on FasTrak and FasTrak SDX.



3-BAG POWERED BAGGER

Bagger has a 12-bushel capacity. Available on X-ONE, Super Z, and HyperDrive.



FLEX FORKS®

Improves operator comfort and provides a more even cut, especially over uneven terrain or at higher speeds.



MULCH KIT

Recycles clippings back into the soil to reclaim nutrients for your lawn.



STEEL SIDE BAGGER

Bagger has a 3.5-bushel capacity. Available on FasTrak, FasTrak SDX, X-ONE, Super S, and TrimStar.



MESH SIDE BAGGER

Bagger has a 3-bushel capacity. Available on FasTrak, FasTrak SDX, X-ONE, Super S, and TrimStar.



STEERING EXTENSION KIT

Allows height adjustment of steering levers to make your mowing experience as comfortable as possible.



LIGHT KIT

Extends your productivity into the late hours. Kit contains two high-quality 12-volt lights with a switch that mounts in the instrument panel.



BACVAC

Electric actuated DFS bagger system. The BACVAC has a 10-bushel capacity. Available on X-ONE, Super Z, and HyperDrive.



MICHELIN® X® TWEEL® TURF

Airless radial tires designed to help eliminate downtime caused by flat tires and unseated beads. Available on X-ONE, Super Z, HyperDrive, and Diesel Z.



STRIPE KIT

Helps provide a professional, manicured finish to your lawn. Depending on the mower, rubber flap or steel cylinder options are available.



SEMI-PNEUMATIC TIRES

Better protection against flat tires.

FASTRAK®



FASTRAK® SDX



X-ONE®



SUPER Z®



HYPERDRIVE®



DIESEL Z



SUPER 104™



AVAILABLE AT CERTIFIED DEALERS

AVAILABLE AT CERTIFIED DEALERS

CUTTING WIDTHS	48", 54" & 60" Side-discharge 48" & 54" Rear-discharge	48", 54" & 60" Side-discharge	52", 60" & 72" Side-discharge 54" & 60" Rear-discharge	54", 60", 66" & 72" Side-discharge 60" & 72" Rear-discharge	60", 66" & 72" Side-discharge 60" & 72" Rear-discharge	60" & 72" Side-discharge 60" & 72" Rear-discharge	104" Rear-discharge
ENGINE CONFIGURATIONS	Kawasaki® 22hp FT691 24hp FT730 KOHLER® 27hp 7500 EFI	Kawasaki 22hp FX691 23.5hp FX730	Kawasaki 23.5hp FX730 24hp FT730 27hp FX850 29.5hp FX850 EFI KOHLER 25hp Command Pro	Kawasaki 27hp FX850 35hp FX1000 38.5hp FX1000 EFI Vanguard® 36hp Big Block	Kawasaki 35hp FX1000 38.5hp FX1000 EFI Vanguard 40hp Big Block EFI 40hp Big Block EFI with Oil Guard	Perkins 25hp	Kawasaki 35hp FX1000 38.5hp FX1000 EFI Vanguard 40hp Big Block EFI with Oil Guard
DECK HEIGHT	Foot-operated. 1.5" to 4.5" (1/4" increments)	Foot-operated. 1.5" to 4.5" (1/4" increments)	Foot-operated. 1" to 5.5" (1/4" increments)	Foot-operated. 1" to 5.5" (1/4" increments)	Foot-operated. 1" to 5.5" (1/4" increments)	Foot-operated. 1" to 5.5" (1/4" increments)	Hydraulic. 1" to 5.5" (1/4" increments)
DRIVE SYSTEM	Commercial-duty Hydro-Gear ZT-3200*. Serviceable w/ spin-on filters.	Commercial-duty Hydro-Gear ZT-3400*. Serviceable w/ spin-on filters.	Parker unitized 12 cc /rev pump and 15.9ci wheel motors	Hydro-Gear 21cc pumps, Parker TG high torque wheel motors, 3 gal. reservoir, oil cooler w/ fan & hot oil shuttle.	HyperDrive industrial Danfoss slipper piston pumps, Parker TG high torque wheel motors, 3 gal. reservoir, oil cooler w/ 9" fan & hot oil shuttle.	Tandem Hydro-Gear 21cc pumps, Parker TG wheel motors, oil cooler with 8" fan	HyperDrive industrial Danfoss slipper piston pumps, Parker TG high torque wheel motors, 3 gal. reservoir, oil cooler w/ 9" fan & hot oil shuttle.
SPEED (FWD)	Up to 10 mph	Up to 10 mph	Up to 10.5 mph	Up to 14 mph	Up to 16 mph	Up to 11.5 mph	Up to 11 mph
FUEL CAPACITY	8.5 US gallons	8.5 US gallons	11.7 US gallons	11.7 US gallons	11.7 US gallons	14.4 US gallons	12 US gallons
ACCESSORIES	<ul style="list-style-type: none"> ▶ Mulch kit ▶ Dump From Seat bagger (8 bushels) ▶ Grass bagger (2-bag powered 7.2 bushels) ▶ Mesh side bagger (3 bushels) ▶ Steel side bagger (3.5 bushels) ▶ Steering lever extension kit ▶ FlexForks® ▶ Light kit ▶ Stripe kit ▶ High vacuum kit 	<ul style="list-style-type: none"> ▶ Mulch kit ▶ Dump From Seat bagger (8 bushels) ▶ Grass bagger (2-bag powered 7.2 bushels) ▶ Mesh side bagger (3 bushels) ▶ Steel side bagger (3.5 bushels) ▶ Steering lever extension kit ▶ FlexForks® ▶ Light kit ▶ Stripe kit ▶ High vacuum kit 	<ul style="list-style-type: none"> ▶ Semi pneumatic front tires ▶ Steering lever extension kit ▶ Deck rear anti-scalp wheels ▶ 3-bag powered bagger (12 bushels) ▶ BacVac bagger (10 bushels) ▶ Mesh side bagger (3 bushels) ▶ Steel side bagger (3.5 bushels) ▶ Flex Forks® ▶ Mulch kit ▶ Light kit ▶ Stripe kit ▶ Electric deck lift ▶ Hitch kit ▶ Michelin® X® Tweel® Turf 	<ul style="list-style-type: none"> ▶ Semi pneumatic front tires ▶ Steering lever extension kit ▶ Deck rear anti-scalp wheels ▶ 3-bag powered bagger (12 bushels) ▶ BacVac bagger (10 bushels) ▶ Flex Forks® ▶ Mulch kit ▶ Light kit ▶ Sand kit ▶ Stripe kit ▶ Beacon kit ▶ Flasher kit ▶ Electric deck lift ▶ Hitch kit ▶ Michelin® X® Tweel® Turf 	<ul style="list-style-type: none"> ▶ Semi pneumatic front tires ▶ Steering lever extension kit ▶ Deck rear anti-scalp wheels ▶ 3-bag powered bagger (12 bushels) ▶ BacVac bagger (10 bushels) ▶ Flex Forks® ▶ Mulch kit ▶ Light kit ▶ Sand kit ▶ Stripe kit ▶ Beacon kit ▶ Flasher kit ▶ Electric deck lift ▶ Hitch kit ▶ Michelin® X® Tweel® Turf 	<ul style="list-style-type: none"> ▶ Semi pneumatic front tires ▶ Steering lever extension kit ▶ Single/dual anti-scalp wheels ▶ Flex Forks® ▶ Mulch kit ▶ Light kit ▶ Sand kit ▶ Stripe kit ▶ Beacon kit ▶ Flasher kit ▶ Electric deck lift ▶ Hitch kit ▶ Michelin® X® Tweel® Turf 	<ul style="list-style-type: none"> ▶ Semi pneumatic front tires ▶ Steering lever extension kit ▶ Flex Forks® ▶ Mulch kit ▶ Light kit ▶ Beacon kit ▶ Flasher kit ▶ Hitch kit ▶ Anti-scalp kit

Specifications are subject to change without notice.

Visit hustlerturf.com for more specs.

SURFER PRO



SUPER S®



SUPER SF



SUPER 88™



TRIMSTAR®



CUTTING WIDTHS	34" & 48" Side-discharge	36", 48", 52", & 60" Side-discharge	60" & 72" Side-discharge	88" Rear-discharge	36", 48" 54" & 60" Side-discharge
ENGINE CONFIGURATIONS	Kawasaki 15hp FS541	Kawasaki 15hp FS541 22hp FT691 19hp FX600 27hp FX850 22hp FX691 29.5hp FX850 EFI	Kawasaki 38.5hp FX1000 EFI Vanguard 40hp Big Block EFI with Oil Guard	Vanguard 36hp Big Block 37hp Big Block EFI with Oil Guard	Kawasaki 15hp FS541 18.5hp FS600 22hp FS651 23hp FS691
DECK HEIGHT	Hand-operated. 2" to 4.75" (1/4" increments)	Hand-operated. 1.5" to 5.5" (1/4" increments)	Hand-operated. 2" to 5.5" (1/4" increments)	Center deck: Electric actuator. Wings: Manual lift with pull-out lift assist handles. 2" to 5.5" (1/4" increments)	Hand-operated. 1.5" to 4.5" (1/4" increments)
DRIVE SYSTEM	Hydro-Gear ZT-1800	36" : Hydro-Gear 10cc pump and Parker TL wheel motor. 48/52/60" : Hydro-Gear 12cc pump and Parker TL wheel motor.	Hydro-Gear 21cc pumps and Parker TG wheel motors	Hydro-Gear 21cc pumps and Parker TG wheel motors	Hydro-Gear ZT-2800® w/ spin-on filters.
SPEED (FWD)	Up to 6 mph	36" : Up to 8 mph 48/52/60" : Up to 9 mph	Up to 15 mph	Up to 10 mph	Up to 6.3 mph
FUEL CAPACITY	2.0 US gallons	36" : 6.5 US gal. 48/52/60" : 7.3 US gal.	13.9 US gallons	13.9 US gallons	3.4 US gallons
ACCESSORIES	<ul style="list-style-type: none"> ▶ Mulch kit ▶ Mesh side bagger (3 bushels) ▶ Light Kit ▶ Stripe kit 	<ul style="list-style-type: none"> ▶ Mulch kit ▶ Mesh side bagger (3 bushels) ▶ Steel side bagger (3.5 bushels) ▶ Light kit ▶ Stripe kit ▶ Trash basket ▶ Cup holder 	<ul style="list-style-type: none"> ▶ Mulch kit ▶ Mesh side bagger (3 bushels) ▶ Stripe kit ▶ Mud Flap kit ▶ Light kit 	<ul style="list-style-type: none"> ▶ Mulch kit ▶ Mud Flap kit ▶ Light kit 	<ul style="list-style-type: none"> ▶ Mulch kit ▶ Mesh side bagger (3 bushels) ▶ Steel side bagger (3.5 bushels) ▶ Stripe kit ▶ High vacuum kit

Specifications are subject to change without notice.

Visit [hustlerturf.com](https://www.hustlerturf.com) for more specs.

Visit [hustlerturf.com/find-a-retailer](https://www.hustlerturf.com/find-a-retailer) to locate your nearest dealer.

HUSTLER FLUID PRODUCTS

Hustler Turf's motor oil, fuel stabilizer and hydrostatic transmission oil products will help keep your machine running smoothly. Ask your local dealer about availability of these products.





HUSTLER®

©2021 HUSTLER TURF EQUIPMENT

SPECIFICATIONS SUBJECT TO CHANGE WITHOUT NOTICE.
VISIT WWW.HUSTLERTURF.COM FOR THE MOST CURRENT
SPECIFICATIONS. 10-21

HUSTLERTURF.COM

