



***Tome 2 - Volume 2***

***Teil 2 - Tomo 2***

**CADET**

**CADET ROLL UP**

**200 - 240 - 260**

**CADET SOLID**

**260 - 285 - 310 - 340**

ZT03744

Edition 17



- CAREFULLY READ THIS MANUAL BEFORE OPERATING YOUR BOAT.
- THIS OWNER'S MANUAL IS IN TWO VOLUMES THAT MUST BE KEPT TOGETHER.

**NOTICE:**

THE OWNER'S MANUAL IS IN TWO VOLUMES:

**- VOLUME 1**

DEALS WITH OPERATING PRECAUTIONS AND SAFETY RECOMMENDATIONS THAT MUST BE OBSERVED.

**- VOLUME 2**

DEALS WITH TECHNICAL SPECIFICATIONS AND ASSEMBLY PROCEDURE OF THE BOAT AND ITS EQUIPMENT.

## **VOLUME 2**

### **TECHNICAL SPECIFICATIONS - ASSEMBLY PROCEDURE**

# **ZODIAC**

## **CADETS**

**CADET ROLL UP 200 - 240 - 260**  
**CADET SOLID 260 - 285 - 310 - 340**

## **CONTENTS**

|                     | <b>Page</b> |                               | <b>Page</b> |
|---------------------|-------------|-------------------------------|-------------|
|                     |             | ⇒Inflation                    | 7           |
| ⇒Assembly procedure | 2           | ⇒Pressure                     | 8           |
| ⇒Check on unpacking | 2           | ⇒Assembly of equipment        | 9           |
| ⇒Assembly           | 3 - 5       | ⇒Deflation - folding the boat | 10          |
| ⇒Inflation system   | 6           | ⇒General description          | I - IV      |

## ASSEMBLY PROCEDURE

We recommend that you follow the specific order of the assembly procedure. Proceed step by step and refer to the corresponding pages.

| PROCEDURE   | PAGE   | SECTION                      |
|---|--------|------------------------------|
| 1. inventory the elements composing your boat,<br>and learn how to recognise them   | 2      | <b>CHECK ON UNPACKING</b>    |
|   | I - IV | <b>DESCRIPTION</b>           |
| 2. activate valves in inflating position  | 6      | <b>INFLATION SYSTEM</b>      |
| 3. slightly inflate the main buoyancy tube  | 7      | <b>INFLATION</b>             |
| 4. <b>CADET RU 200 - RU 240</b> : Insert the wooden slats in their pockets<br><b>CADET RU 260</b> : install the rolling floor<br><b>CADET SOLID</b> : assemble the floorboard | 3 - 5  | <b>ASSEMBLY</b>              |
| 5. Install the seat (except <b>CADET RU 200</b> )   | 9      | <b>ASSEMBLY OF EQUIPMENT</b> |
| 6. finish inflation of the boat to the correct pressure   | 7 - 8  | <b>INFLATION / PRESSURE</b>  |
| 7. Install the oars   | 9      | <b>ASSEMBLY OF EQUIPMENT</b> |

## CHECK ON UNPACKING

|   |                                |
|---|--------------------------------|
| <br><b>CAUTION</b> | <b>DO NOT USE A SHARP TOOL</b> |
|---|--------------------------------|

The pack must contain: 1 buoyancy tube +

|  <b>Cadet Roll up<br/>Cadet Solid</b> | C200RU       | C240RU       | C260RU       | C260S         | C285S         | C310S         | C340S         |
|--|--------------|--------------|--------------|---------------|---------------|---------------|---------------|
| Floorboard   | <b>S (1)</b> | <b>S (1)</b> | <b>R (1)</b> | <b>PF (1)</b> | <b>PF (1)</b> | <b>PF (1)</b> | <b>PF (1)</b> |
| inflatable keel  |              |              |              | <b>1</b>      | <b>1</b>      | <b>1</b>      | <b>1</b>      |
| Stringer   |              |              |              | <b>2</b>      | <b>2</b>      | <b>2</b>      | <b>2</b>      |
| Repair kit   | <b>1</b>     | <b>1</b>     | <b>1</b>     | <b>1</b>      | <b>1</b>      | <b>1</b>      | <b>1</b>      |
| Owner's manual (2)   | <b>1</b>     | <b>1</b>     | <b>1</b>     | <b>1</b>      | <b>1</b>      | <b>1</b>      | <b>1</b>      |

| <b>Equipement standard</b> |          |          |          |          |          |          |          |
|----------------------------|----------|----------|----------|----------|----------|----------|----------|
| Removable wooden seat      |          | <b>1</b> | <b>1</b> | <b>1</b> | <b>1</b> | <b>1</b> | <b>1</b> |
| Carry bag                  | <b>1</b> | <b>1</b> | <b>1</b> | <b>1</b> | <b>1</b> | <b>1</b> | <b>1</b> |
| Reinforced aluminium oar   | <b>2</b> | <b>2</b> | <b>2</b> | <b>2</b> | <b>2</b> | <b>2</b> | <b>2</b> |
| Foot-pump                  | <b>1</b> | <b>1</b> | <b>1</b> | <b>1</b> | <b>1</b> | <b>1</b> | <b>1</b> |

(1) S = Slats    R = Rolling floor    PF = Marine Plywood Floor  
 (2) 2 volumes

You can equip your boat with many optional accessories (transportation wheels, boarding ladder, lifting rings etc.). Ask your dealer to advise you.

|                 |   |
|-----------------|---|
| <b>NOTICE :</b> | <b>IF YOU WISH TO ADD LIFTING RINGS, YOU MUST FIX THEM ON THE BUOYANCY TUBE, NEVER ON THE FLOOR</b> |
|-----------------|---|

## ASSEMBLY

Choose a smooth and clean surface



**IF THE BUOYANCY TUBE WAS STORED AT A TEMPERATURE BELOW 0°C / 32°F, LEAVE IT AT 20°C / 68°F FOR 12 HOURS BEFORE UNFOLDING.**

### CADET SOLID : INSTALL THE MARINE PLYWOOD FLOOR:

- Sprinkle some starch in the angle (joint of the buoyancy tubes to the bottom) to facilitate fitting. **CAUTION, NEVER USE TALCUM POWDER.**
  - **Make sure you identify the parts and direction in which they fit:**
    - The floorboard consists of 3 main sections and 2 sections in the bow [fig 1 and 4]
    - The bow sections have an upside and a downside.
1. Insert the bow section (1) into the bow angle.
  2. Insert the rear section (5) against the transom (6) as show on fig 1.
  3. Fit all sections together [fig.1].
  4. Position sections 3 and 4 as an apex (in a tent-like position) [fig 1 and 2].
  5. Check that all sections are correctly aligned [fig 4].
  6. Check that the floorboard is correctly fitted in the angles.
  7. Flatten the apex by standing on it (in the boat) and pulling the lifelines to prevent the fabric being pinched [fig. 2].
  8. Assemble the stringers (see instructions below).

### CADET SOLID : ASSEMBLY OF THE STRINGERS

The stringers are essential to good working of the boat: they lock the floorboard together and stiffen its structure.

1. To facilitate the fitting of the first stringer, slide the other stringer under the boat, about 20 cm from the side [fig. 3-a].



**DO NOT PUT THE STRINGER IN POSITION UNDER THE BOAT UNTIL THE FLOOR IS FLATTENED.**

2. Position the stringer on the edge of the floorboard. The reference mark on the stringer (8) must remain on top (**the thicker part should be towards the top**) [fig. 3].
3. Fit the stringers between the two buffers (9) of sections 3 and 5 [fig. 4].
4. Rotate the stringer in the angle so as to press them against the bottom [fig. 3-b and 4].
5. Because of the self-locking system of the floorboard, the stringers will fit into place once the buoyancy tube is inflated.

# ASSEMBLY

fig 1-A

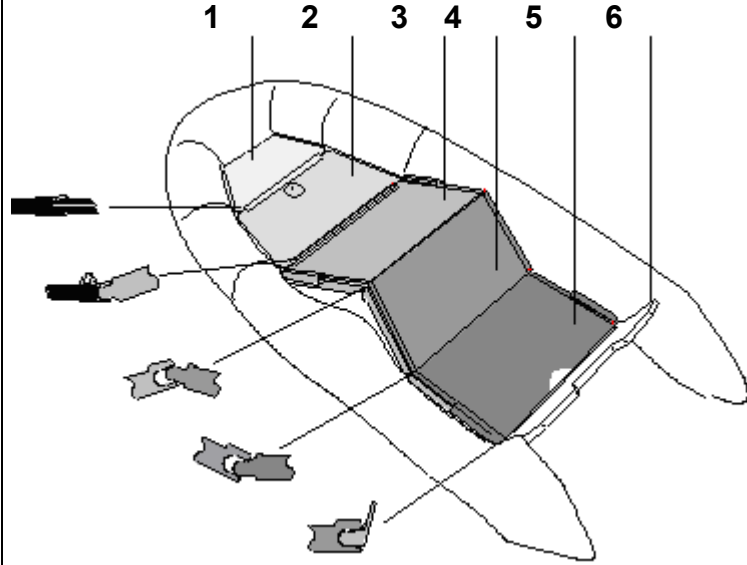

fig 1-B

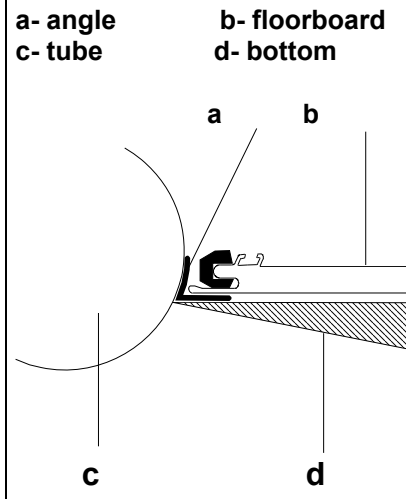

fig 2

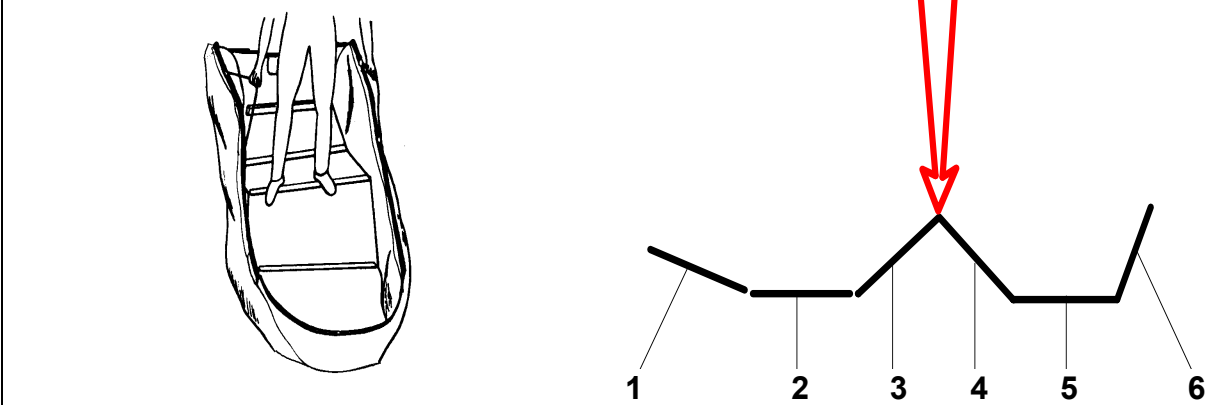

fig 3

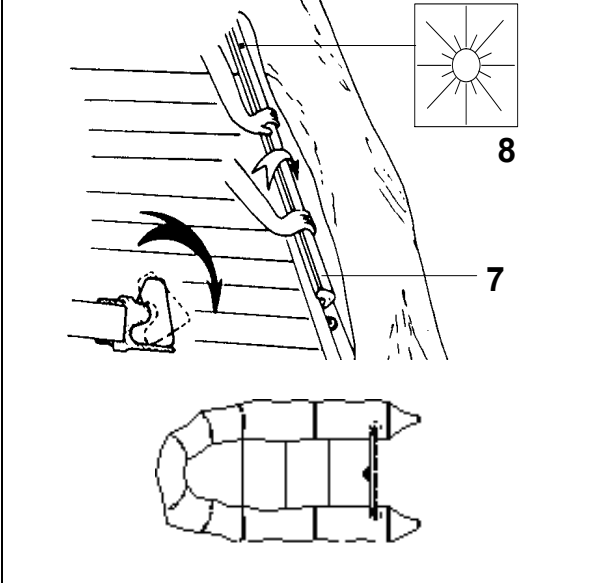
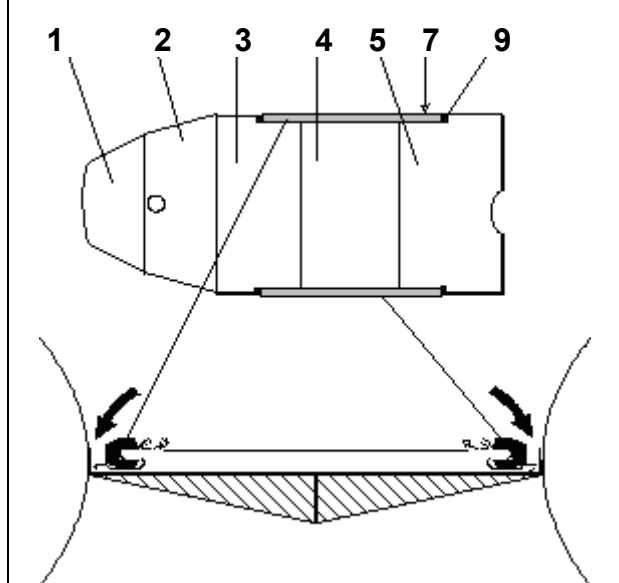

fig 4



## ASSEMBLY

### CADET ROLL UP 200 - 240: INSTALL THE SLATTED FLOOR:

Boat deflated, slide the slats in their pockets starting by the closest to the transom. If the slats are difficult to insert, lubricate it with liquid soap.

### CADET ROLL UP 260 : INSTALL THE ROLLING FLOOR:

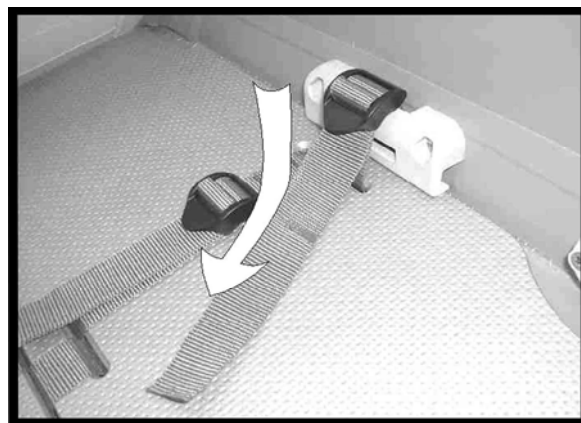
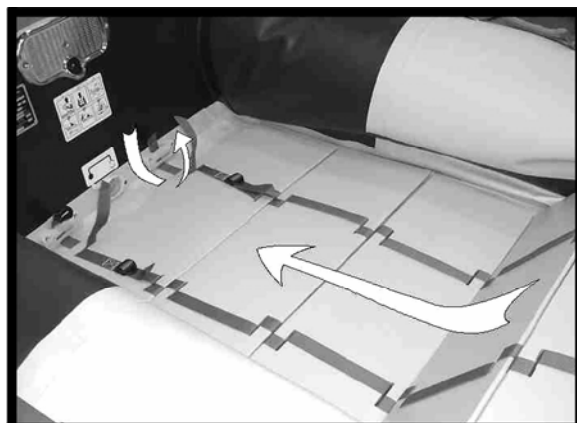

## INFLATION SYSTEM

The inflation system is composed of:

### THE FOOT PUMP

- a. connecting tip
- b. hose end piece
- c. hose base
- d. outlet for inflation

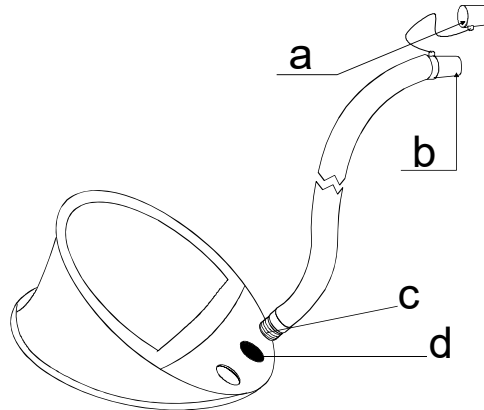

### THE STANDARD VALVES

(1) cap (2) valve insert (3) base

**To activate the standard valves into INFLATION position:**

- Free the valve insert from its protection.
- Unscrew the valve cap.
- Screw the valve support onto its base (screw it tight but without exaggeration, not to deteriorate the screw thread) and check that the valve cap stays accessible.

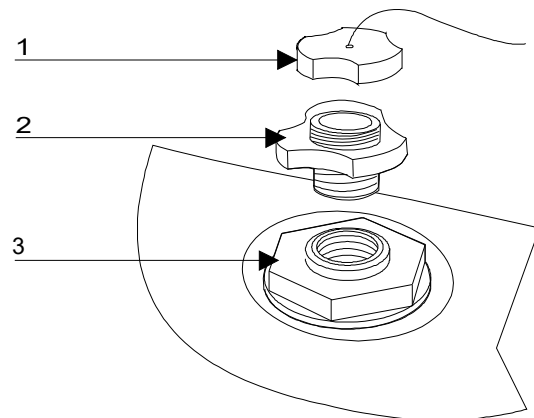

**TO DEFLATE:**

Unscrew the valve support from its base

### THE VALVES « EASY – PUSH ».

| To change the position:                               | Inflation position  | Deflation position                                |
|---|---|---|
| <p style="font-size: 1.2em; font-weight: bold;">↓</p> |   |   |
| <b>Push / Push</b>                                    | <b>diaphragm closed, the inner button springs upwards</b> | <b>diaphragm open, the inner button goes down</b> |

## INFLATION

Activate all valves into inflation position.

Fit the hose to the foot-pump.  
To inflate your boat properly, the bottom side of the foot-pump must rest on a flat ground.  
Pump evenly to inflate rapidly.

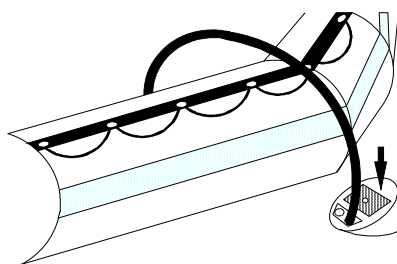

**CAUTION**

**DO NOT USE A COMPRESSOR OR A BOTTLE OF COMPRESSED AIR**

You can use the electrical air pump *ACCESS* (ask your Dealer).

### TO INFLATE THE MAIN BUOYANCY TUBE

- Insert the pump hose end piece
- Inflate (**pressure = 240 mb, refer to PRESSURE section**) making sure that each compartment is equal. When correctly inflated, the internal bulkheads (a) are not visible.



**NEVER COMPLETELY INFLATE A COMPARTMENT TO FULL PRESSURE IF OTHER COMPARTMENTS ARE TOTALLY DEFLATED**

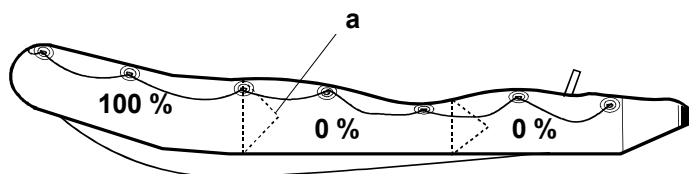

1

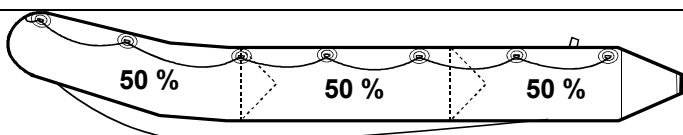

2

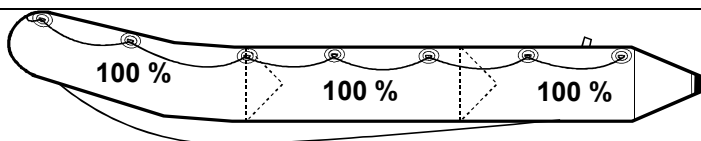

### CADET SOLID : INFLATE THE KEEL

- Once the floor is assembled, start inflation of the keel (**pressure = 240 mb**).

**Inflation is over:** fit the valve caps tight (clockwise).

**NOTICE :**

A slight air-leak before screwing the valve caps is normal.  
**ONLY THE VALVE CAPS CAN ENSURE FINAL AIR TIGHTNESS.**



## PRESSURE

**The correct pressure for the buoyancy tube and the keel is 240 mb / 3,4 PSI** (green area of the pressure indicator).

If your boat is not equipped with a **ACCESS** pressure indicator, we recommend that you purchase one from your Dealer. This will permit a quick and efficient control of the pressure during inflation. Without a pressure indicator, stop inflating when the foot-pump gets difficult to operate, and the boat is « hard » (you should not be able to bend the cone ends).

Ambient temperature of air and water have an effect on the boat's internal pressure

| Ambient temperature | tubes' internal pressure |
|---------------------|--------------------------|
| +1°C / +1,8°F       | +4 mb / 0,06 PSI         |
| -1°C / -1,8°F       | -4 mb / 0,06 PSI         |

**Therefore, it is important to anticipate:**

Because of temperature variations (especially when this variation is important between the beginning and the end of the day, in hot areas) check and adjust the pressure in the inflated compartments by inflating or deflating. Be sure that pressure remains within the recommended zone, between 220 mb/3,10 PSI and 270 mb/3,85 PSI (green area).

### RISK OF UNDERPRESSURE

**EXAMPLE:** Your boat is in direct sunlight on the beach (temperature =50°C/122°F) at recommended pressure (240 mb/3,4 PSI). after putting it in the colder water (temperature =20°C/68°F), the internal temperature and pressure of the tubes will both drop (up to 120 mb/1,7 PSI) and **YOU WILL HAVE TO INFLATE AGAIN** until you regain the lost pressure due to the difference in temperatures. Therefore, a loss of pressure at the end of the day when ambient temperature drops is perfectly normal.

**NOTICE :**

**Proper inflation is critical to the performance of the boat. It is the pressure in the tubes that gives your boat the necessary rigidity to perform well. Under-inflation causes improper flexing of the tubes which will result in stress and chafe**

### RISK OF OVERPRESSURE

**EXAMPLE:** Your boat is inflated to the recommended pressure (240 mb/3,4 PSI) at the beginning of the day (low ambient temperature =10°C/50°F). Later in the day, your boat is in direct sunlight on the beach or on a yacht's deck (temperature =50°C/122°F). Internal temperature of all inflated compartments can then increase and reach up to 70°C/158°F (especially for dark-coloured tubes). The consequence will be a doubling of previous pressure (480 mb/6,8 PSI). **YOU WILL THEN HAVE TO DEFLATE** until you reach the recommended pressure.



**WHEN YOUR BOAT IS OVER INFLATED, PRESSURE BECOMES TOO STRONG FOR THE INFLATABLE STRUCTURE, AND COULD CAUSE A BREAK IN THE FABRIC ASSEMBLY**

### IN CASE OF OVERPRESSURE

**STANDARD VALVE (A):**

Free some air by pushing on the diaphragm (1) with a blunt object.

**Beware not to fold down the diaphragm.**

**SEMI-RECESSED VALVE (B):**

Deflate by pressing the spring loaded button.

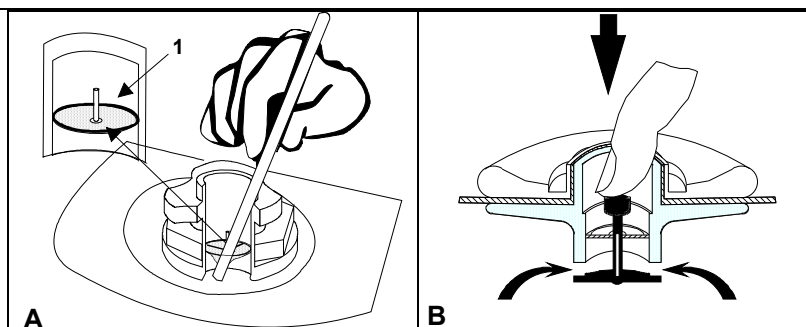

**ASSEMBLY OF STANDARD EQUIPMENT**

**TO ASSEMBLE AND INSTALL THE OARS:**

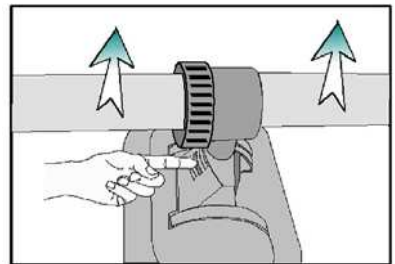
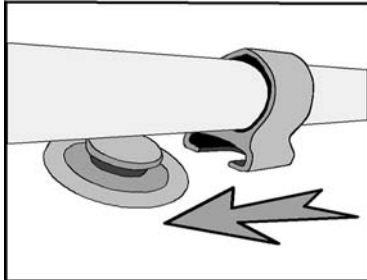
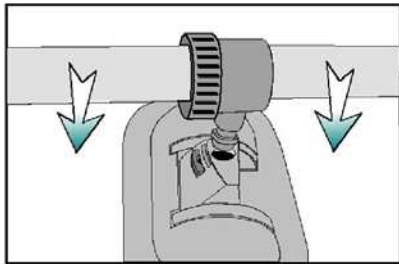
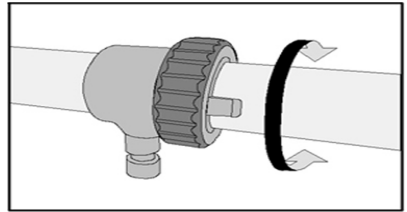
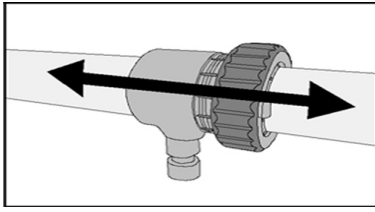
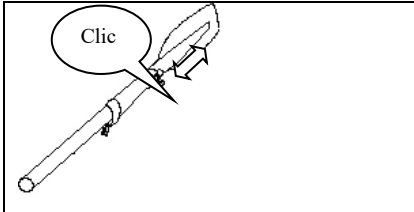
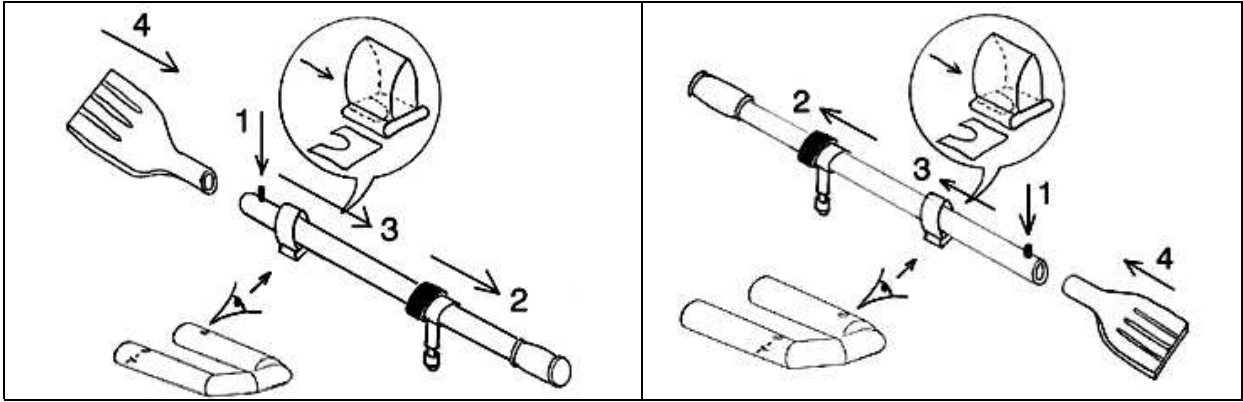

**THE REMOVABLE SEAT (EXCEPT C 200 ROLL UP)**

Install the seat before the boat is totally inflated.

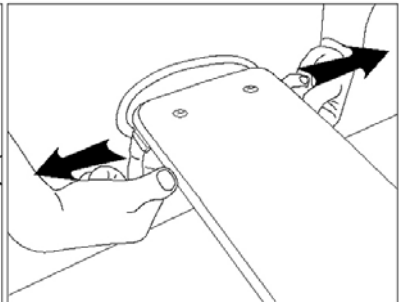
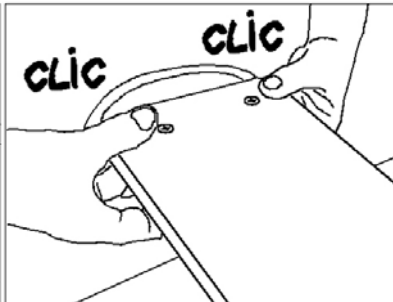
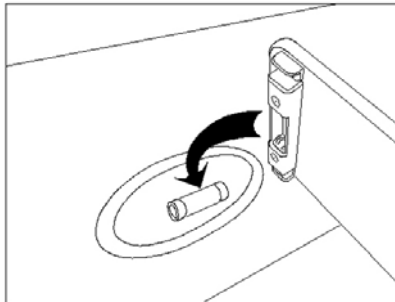

**E  
N  
G  
L  
I  
S  
H**

## DEFLATING / FOLDING THE BOAT

1. **Deflate** the boat.
2. **Replace** the valve protections.
3. **Remove** oars and equipment.
4. **Remove** the floorboard (For Cadets solid only - for cadets Roll up with a slatted floor, It is not necessary to remove the slats to fold the boat).
5. **Empty** the boat of all water and sand by opening the self-bailers, dry it.
6. **Fold in** the 2 sides of the main buoyancy tube (A), fold the cones onto the transom, then **roll up** the boat around the transom (C). Start again if you feel there is still some air left in the tubes.

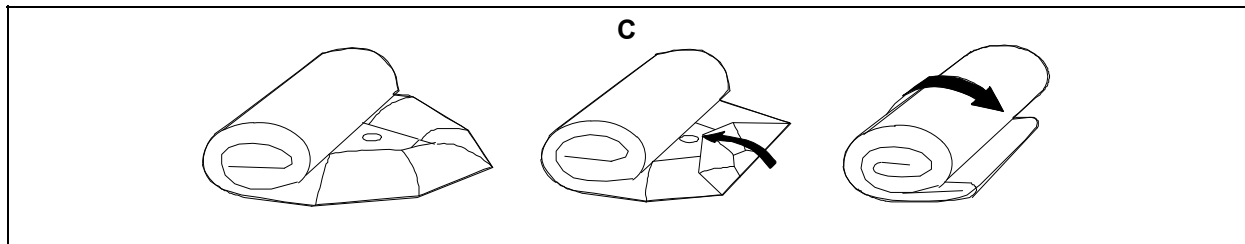
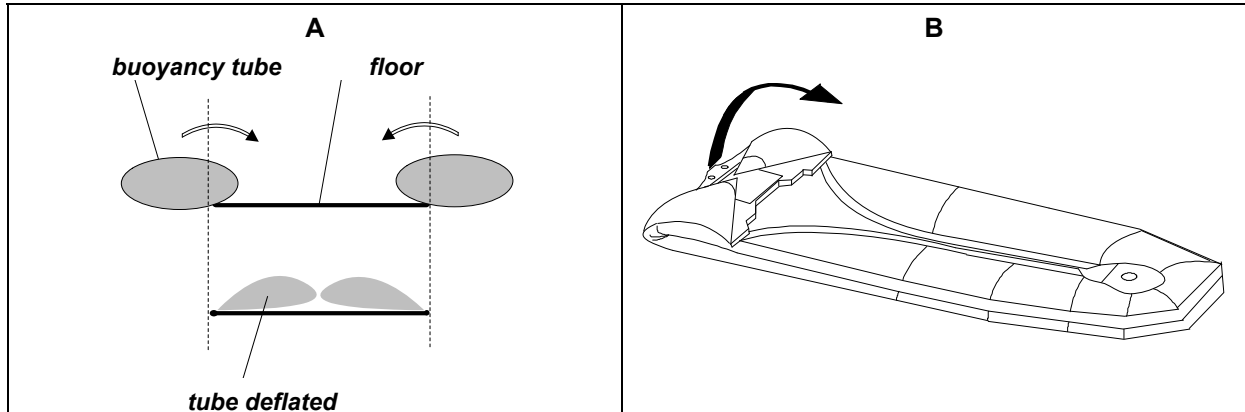

**Stow** the boat in its bag as follows (D):

- . **Stow** the boat folded on its bag open (back side of the bag visible).
- . **Position** the floor sections and stringers flat on the boat (Cadet Solid), then the oars dismantled.
- . **Close** the bag and fasten the two front straps.
- . **Tight** the side ropes (make sure that all equipment stays inside).
- . **To finish**, store the foot-pump in the front pocket.

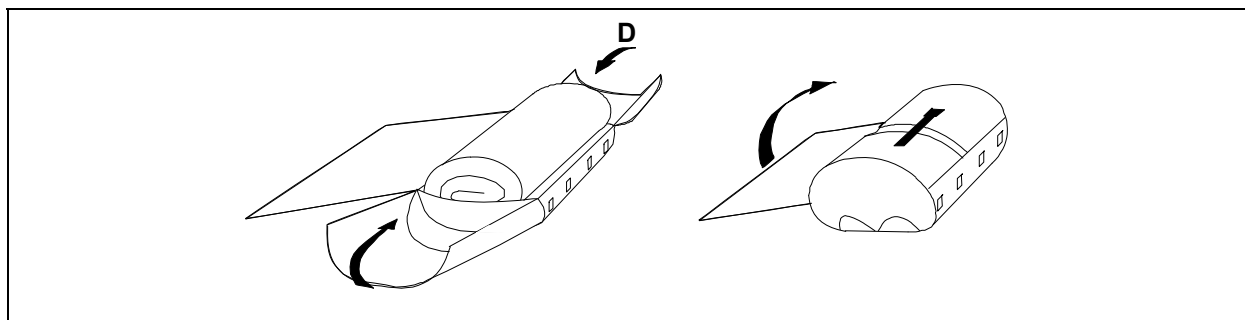



**DESCRIPTION**



**DESCRIPTION - BESCHREIBUNG**

**DESCRIZIONE - DESCRIPCIÓN**

**DESCRIPTION - DESCRIPTION - BESCHREIBUNG - DESCRIZIONE - DESCRIPCIÓN**

|   |                                      |                       |                       |                       |                      |                      |                      |                      |
|---|--------------------------------------|-----------------------|-----------------------|-----------------------|----------------------|----------------------|----------------------|----------------------|
|  | <b>CADET Roll up<br/>CADET Solid</b> | <b>200<br/>Rollup</b> | <b>240<br/>Rollup</b> | <b>260<br/>Rollup</b> | <b>260<br/>Solid</b> | <b>285<br/>Solid</b> | <b>310<br/>Solid</b> | <b>340<br/>Solid</b> |
|---|--------------------------------------|-----------------------|-----------------------|-----------------------|----------------------|----------------------|----------------------|----------------------|

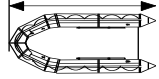
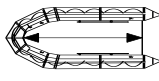

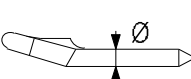

**Dimensions - Dimensions - Dimensioni - Abmessungen - Dimenciones**

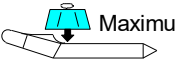
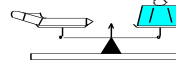
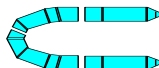
|   |      |                |                |                |                |                |                |                |
|---|------|----------------|----------------|----------------|----------------|----------------|----------------|----------------|
|  | (m)  | 2.00           | 2.40           | 2.60           | 2.60           | 2.85           | 3.10           | 3.40           |
|   | (ft) | 6'7"           | 7'11"          | 8'6"           | 8'6"           | 9'4"           | 10'2"          | 11'2"          |
|  | (m)  | 1.23           | 1.55           | 1.72           | 1.72           | 1.95           | 2.17           | 2.48           |
|   | (ft) | 4'             | 5' 1"          | 5' 8"          | 5' 8"          | 6' 5"          | 7' 1"          | 8' 2"          |
|  | (m)  | 1.54           | 1.54           | 1.61           | 1.61           | 1.61           | 1.61           | 1.79           |
|   | (ft) | 5'             | 5'             | 5' 3"          | 5' 3"          | 5' 3"          | 5' 3"          | 5' 10"         |
|  | (m)  | 0.70           | 0.70           | 0.70           | 0.70           | 0.70           | 0.70           | 0.78           |
|   | (ft) | 2'4"           | 2'4"           | 2'4"           | 2'4"           | 2'4"           | 2'4"           | 2' 7"          |
|  | (m)  | 0.36<br>0.40   | 0.36<br>0.40   | 0.40<br>0.45   | 0.40<br>0.45   | 0.40<br>0.45   | 0.40<br>0.45   | 0.45<br>0.50   |
|   | (ft) | 1' 2"<br>1' 4" | 1' 2"<br>1' 4" | 1' 4"<br>1' 6" | 1' 4"<br>1' 6" | 1' 4"<br>1' 6" | 1' 4"<br>1' 6" | 1' 6"<br>1' 8" |

**Capacité - Capacity - Capacità - Kapazität - Capacidad**

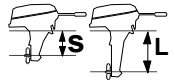
|   |       |     |     |     |     |     |     |      |
|---|-------|-----|-----|-----|-----|-----|-----|------|
|  (ISO)     |       | 2   | 3   | 3+1 | 3+1 | 4   | 5   | 5+1  |
|  Maximum | Kg*   | 190 | 250 | 300 | 370 | 400 | 450 | 750  |
|   | lb.*  | 419 | 551 | 661 | 815 | 881 | 992 | 1653 |
|          | Kg ** | 19  | 23  | 30  | 35  | 36  | 39  | 49   |
|   | lb.** | 42  | 51  | 66  | 73  | 79  | 86  | 108  |
|          |       | 2   | 2   | 2   | 2+1 | 2+1 | 2+1 | 3+1  |

**Motorisation - Outboard data - Motorizzazione - Außenbordmotor - Motorización**

|   |               |     |    |    |     |     |     |     |
|---|---------------|-----|----|----|-----|-----|-----|-----|
|          |               | S   | S  | S  | S   | S   | S   | S   |
|          | Maximum CV*** | 4   | 4  | 4  | 6   | 8   | 15  | 20  |
|   | Maximum kW*** | 3   | 3  | 3  | 4.5 | 6   | 12  | 15  |
|          | Medium CV***  | 3.5 | 4  | 4  | 4   | 6   | 10  | 15  |
|   | Medium kW***  | 2.5 | 3  | 3  | 3   | 4.5 | 8   | 12  |
|  Maximum | kg            | 27  | 27 | 27 | 27  | 42  | 55  | 55  |
|   | Lbs.          | 60  | 60 | 60 | 60  | 93  | 121 | 121 |

**Encombremet - Storage dimensions - Ingombro - Packmaße - Dimenciones**

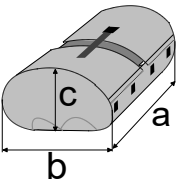
|   |   |               |               |                |                |                |                |                |
|---|---|---------------|---------------|----------------|----------------|----------------|----------------|----------------|
|  | a | 0.90<br>3'    | 1.0<br>3'3"   | 1.0<br>3' 3"   | 1.0<br>3' 3"   | 1.0<br>3' 3"   | 1.0<br>3' 3"   | 1.17<br>3' 10" |
|   | b | 0.45<br>1' 6" | 0.45<br>1' 6" | 0.55<br>1' 10" | 0.55<br>1' 10" | 0.55<br>1' 10" | 0.55<br>1' 10" | 0.58<br>1' 11" |
|   | c | 0.20<br>9"    | 0.20<br>9"    | 0.30<br>1'     | 0.35<br>1' 2"  | 0.35<br>1' 2"  | 0.35<br>1' 2"  | 0.35<br>1' 2"  |

|   |   |   |   |   |   |   |   |
|---|---|---|---|---|---|---|---|
|  (94/25 CE - 03/44 CE) | - | - | D | D | D | C | C |
|---|---|---|---|---|---|---|---|

**DESCRIPTION - DESCRIPTION - BESCHREIBUNG - DESCRIZIONE - DESCRIPCIÓN**

|   |   |
|---|---|
| <b>NOTE<br/>NOTICE :<br/>NOTA :<br/>HINWEIS :</b> | Toutes les mesures indiquées sont susceptibles de varier de + ou - 3%<br>All dimensions indicated have a tolerance of +/- 3%<br>Tutte le dimensioni indicate hanno una tolleranza del +/- 3%<br>Alle angegebenen Abmessungen haben eine Toleranz von +/- 3%.<br>Todas las dimensiones tienen una tolerancia de +/- 3% |
|---|---|

\* The maximum payload has been calculated according to ISO standards. Operating at or near maximum payload is only advised in calm water and at reduced speeds.  
\*\* The weights indicated do not include any accessories  
\*\*\*The spread of engine sizes corresponds to the efficient use of the boat with an average load. The minimum power is exploitable in relaxed activities, such as fishing, while the maximum recommended power is destined for performance activities such as water-skiing.  
Where the maximum power exceeds the recommended power it must be treated with extreme care.

\* La charge maximale autorisée a été calculée selon la norme ISO. Il est recommandé de naviguer avec précaution lorsque le bateau est chargé au maximum.  
\*\* Poids indiqués hors accessoires  
\*\*\*Les puissances conseillées correspondent à une exploitation optimale des capacités du bateau pour une charge moyenne. Selon l'utilisation, vous choisirez la puissance maximale (ski nautique) ou minimale (pêche, promenade).  
Utilisez la puissance maximale autorisée avec une extrême prudence (voir Tome 1 du manuel chapitre "Conseils de navigation").

\* La portata massima autorizzata è calcolata in conformità alla normativa ISO. In condizioni di massimo carico si raccomanda di navigare con particolare prudenza.  
\*\* Pesi s'intendono accessori esclusi  
\*\*\*Le potenze suggerite corrispondono ad uno sfruttamento ottimale delle capacità del battello, in condizioni medie di carico. In funzione del tipo di utilizzo prevalente, potrà essere preferita la motorizzazione massima (sci nautico) o minima (pesca, impiego familiare).  
La potenza massima autorizzata deve essere sfruttata con prudenza.

\* Die zulässige Nutzlast wurde gemäß ISO-Normen berechnet. Fahren mit oder nahe der zulässigen Nutzlast ist nur empfehlenswert in ruhigem Wasser und mit reduzierter Geschwindigkeit.  
\*\* Die Gewichtsangaben beinhalten kein Zubehör  
\*\*\*Die Bandbreite der Motorleistung entspricht einer optimalen Nutzung des Bootes bei durchschnittlicher Zuladung. Die minimale Motorleistung ist für entspannende Tätigkeiten wie Angeln, während die maximal empfohlene Motorleistung für hohe Fahrleistung wie Wasserski bestimmt ist.  
Ist die zulässige Motorleistung größer als die empfohlene, muß mit äußerster Vorsicht gehandelt werden.

\* La carga máxima autorizada se ha calculado según la norma ISO. Se recomienda navegar con precaución cuando la embarcación esté cargada al máximo.  
\*\* Pesi s'intendono accessori esclusi  
\*\*\*Las potencias aconsejadas corresponden a una explotación óptima de las capacidades de la embarcación para una carga media. Según la utilización, escogerá la potencia máxima (esquí náutico) ó mínima (pesca, paseo).  
Utilice la potencia máxima autorizada con extrema prudencia.

| <b>DESCRIPTION - DESCRIPTION - BESCHREIBUNG - DESCRIZIONE - DESCRIPCIÓN</b> |  |   |  |   |  |
|---|--|---|--|---|--|
|   | <b>Français</b>  | <b>English</b>                                    | <b>Italiano</b>  | <b>Deutsch</b>  | <b>Español</b>   |
| <b>1</b>  | fixation sac avant<br>(option)                                     | bow bag fixation<br>(option)                      | attacco borsa di<br>prua   | Befestigung<br>(Bugstausack)  | fijación bolsa de<br>proa (opcionale)                              |
| <b>2</b>  | valve quille   | keel valve  | valvola di chiglia   | Ventile (Luftkeil)  | válvula de la<br>quilla  |
| <b>3</b>  | valve gonflement<br>flotteur                                       | main buoyancy<br>tube valve                       | valvola di<br>gonfiaggio<br>tubolari                               | Ventile<br>(Schauchkörper)  | válvula flotador<br>principal                                      |
| <b>4</b>  | banc de nage<br>amovible<br>(sauf C200)                            | removable<br>wooden seat<br>(except C200)         | Panchetta<br>amovibile<br>(eccetto C200)                           | herausnehmbare<br>Sitzducht<br>(außer C200)                             | banqueta de remo<br>amovible<br>(excepto C200)                     |
| <b>5</b>  | Longerons<br>(260s/285S/<br>310S/340S)                             | stringers<br>(260S/285S/<br>310S/340S)            | longheroni<br>(260S/285S/<br>310S/340S)                            | Längsholme<br>(260S/285S/<br>310S/340S)                                 | larguero<br>(260S/285S/<br>310S/340S)                              |
| <b>6</b>  | plancher en<br>contreplaqué<br>marine<br>(260S/285S/<br>310S/340S) | marine plywood<br>floor (260S/285S/<br>310S/340S) | Pagliolato in<br>compensato<br>marino<br>(260S/285S/<br>310S/340S) | Bodenelemente<br>aus<br>Marinesperrholz<br>(C260S/C285S/C3<br>10S/340S) | enjaretado<br>contrachapado<br>marino<br>(260S/285S/<br>310S/340S) |
|   | lattes amovibles<br>(200 RU/240 RU)                                | removable<br>wooden slats<br>(200RU/240RU)        | Pagliolato a listelli<br>(200 RU/240 RU)                           | herausnehmbarer<br>Lattenboden (200<br>RU/240 RU)                       | tabillas extraibles<br>(200 RU/240 RU)                             |
|   | Plancher<br>déroulant<br>(C260 RU)                                 | Rolling floor<br>(C260 RU)                        | pagliolato<br>avvolgibile.(260RU)                                  | Rolldeck<br>(C260RU)  | suelo<br>enrollable<br>(C260RU)                                    |
| <b>7</b>  | repos d'avirons  | oar rest  | Sistemi di<br>fissaggio dei remi                                   | Ruderfixierungen  | sujeta remos   |
| <b>8</b>  | Cône tronqué   | Truncated cone                                    | Coni tronchi   | Stumpfkegel   | Conos truncados  |
| <b>9</b>  | Renfort de cône  | Reinforced cone<br>end                            | Coni di poppa<br>rinforzati  | Verstärkte<br>heckkonn  | Refozado de cono   |
| <b>10</b>   | tableau arrière  | transom   | specchio di poppa  | Heckspiegel   | tabla popa   |
| <b>11</b>   | taquets tableau<br>arrière   | retaining batten                                  | tasselli   | Beiden<br>Niederhalter  | cuñas  |
| <b>12</b>   | supports dames<br>de nage  | rowlock blocks                                    | Scalmi basculanti  | klappbare<br>Ruderdollen  | soportes<br>chumaceras   |
| <b>13</b>   | poignées   | handles   | maniglie   | griffe  | asa  |
| <b>14</b>   | quille gonflable   | inflatable keel                                   | chiglia gonfiabile   | Luftkeil  | quilla hinchable   |
| <b>15</b>   | poignée de<br>portage  | carrying handle                                   | maniglie de<br>transporto  | Tragegriffe   | asa de transporte  |
| <b>16</b>   | anneau de<br>remorquage  | towing ring                                       | anelli di rimorchio  | Schleppringe  | anilla de arrastre   |
| <b>17</b>   | bande antiragage<br>périmétrique<br>nervurée                       | non-scuff rubbing<br>strake                       | bottaccio di<br>protezione piatto<br>perimetrale                   | verstärkte<br>Rundum-<br>Scheuerleiste                                  | defensa periférica   |
| <b>18</b>   | vide vite  | self bailer                                       | autovuotanti   | selbstlenzende<br>Ventile   | Desagües   |

DESCRIPTION - BESCHREIBUNG - DESCRIZIONE - DESCRIPCIÓN

CADET SOLID 260 S - 285 S - 310 S - 340 S

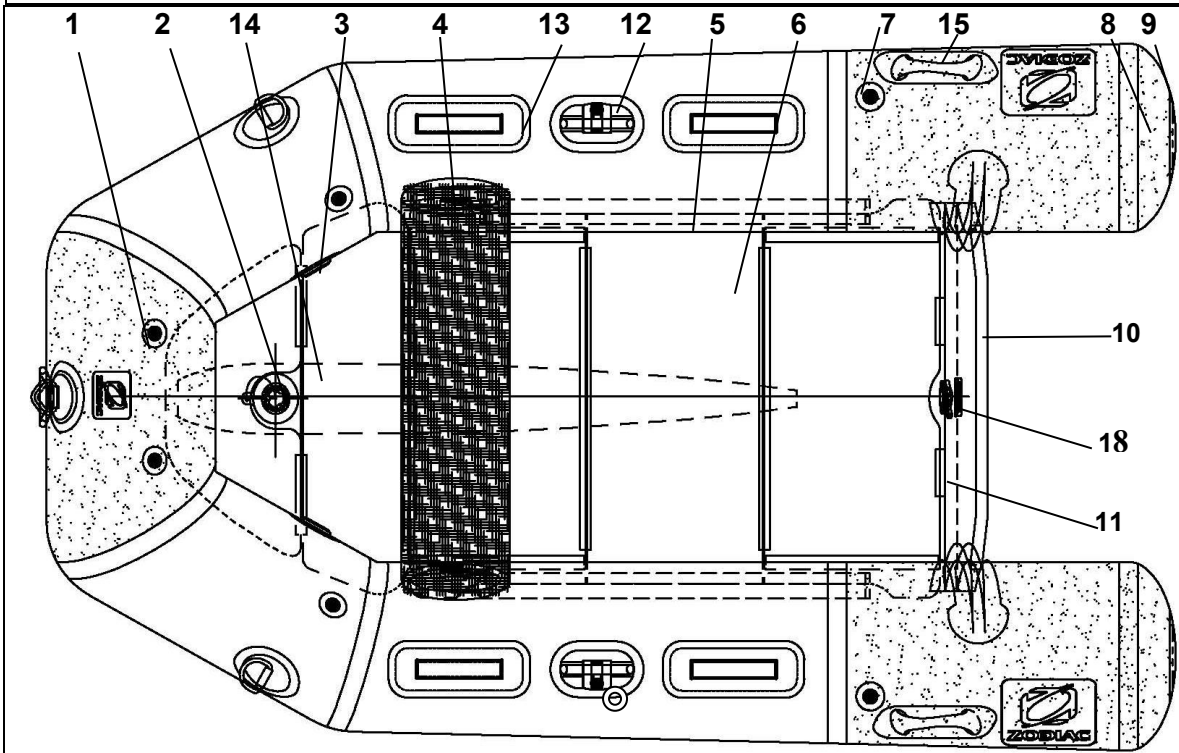

CADET ROLL UP 200 RU - 240 RU - 260 RU

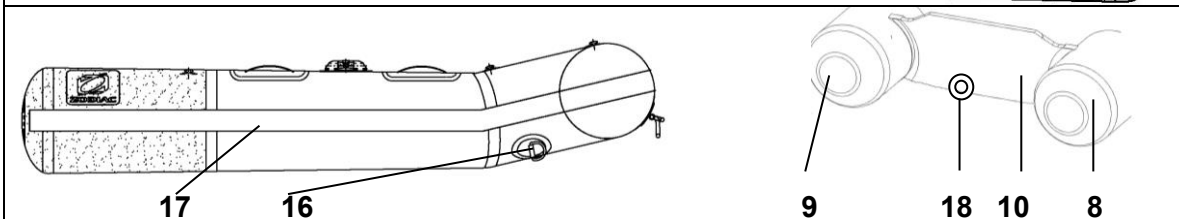
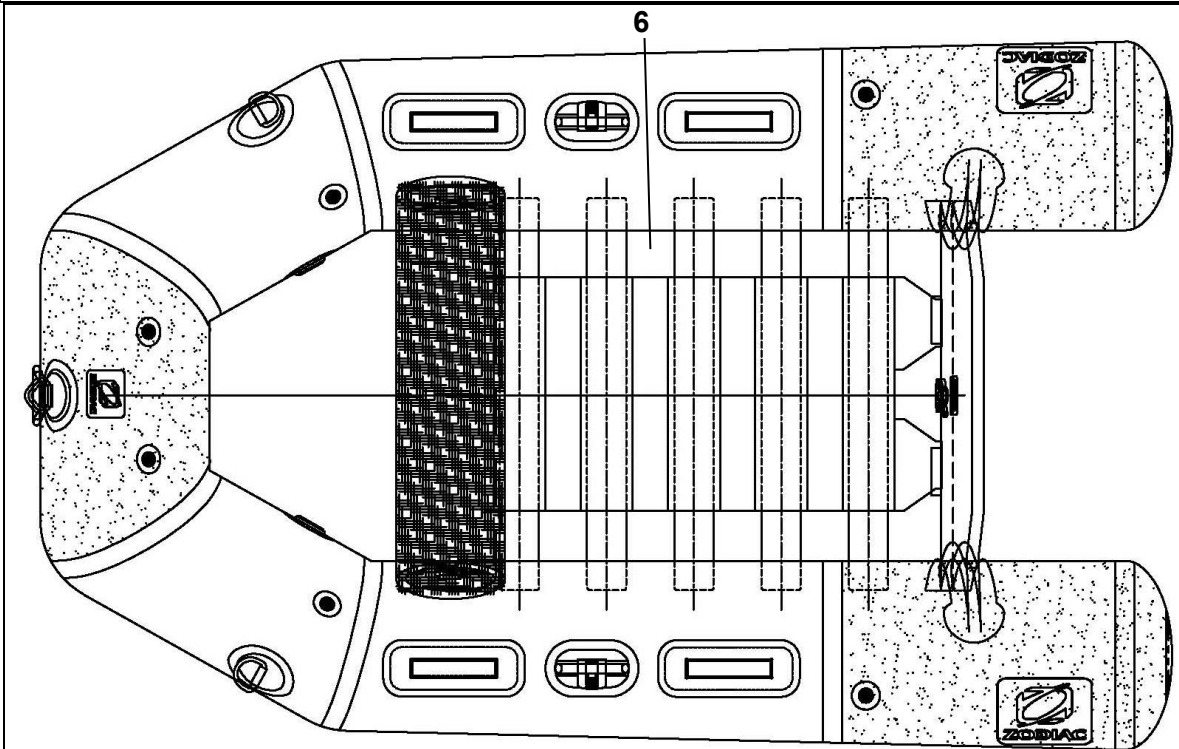





**2 chemin de la Val Priout**  
31450 AYGUESVIVES  
FRANCE