

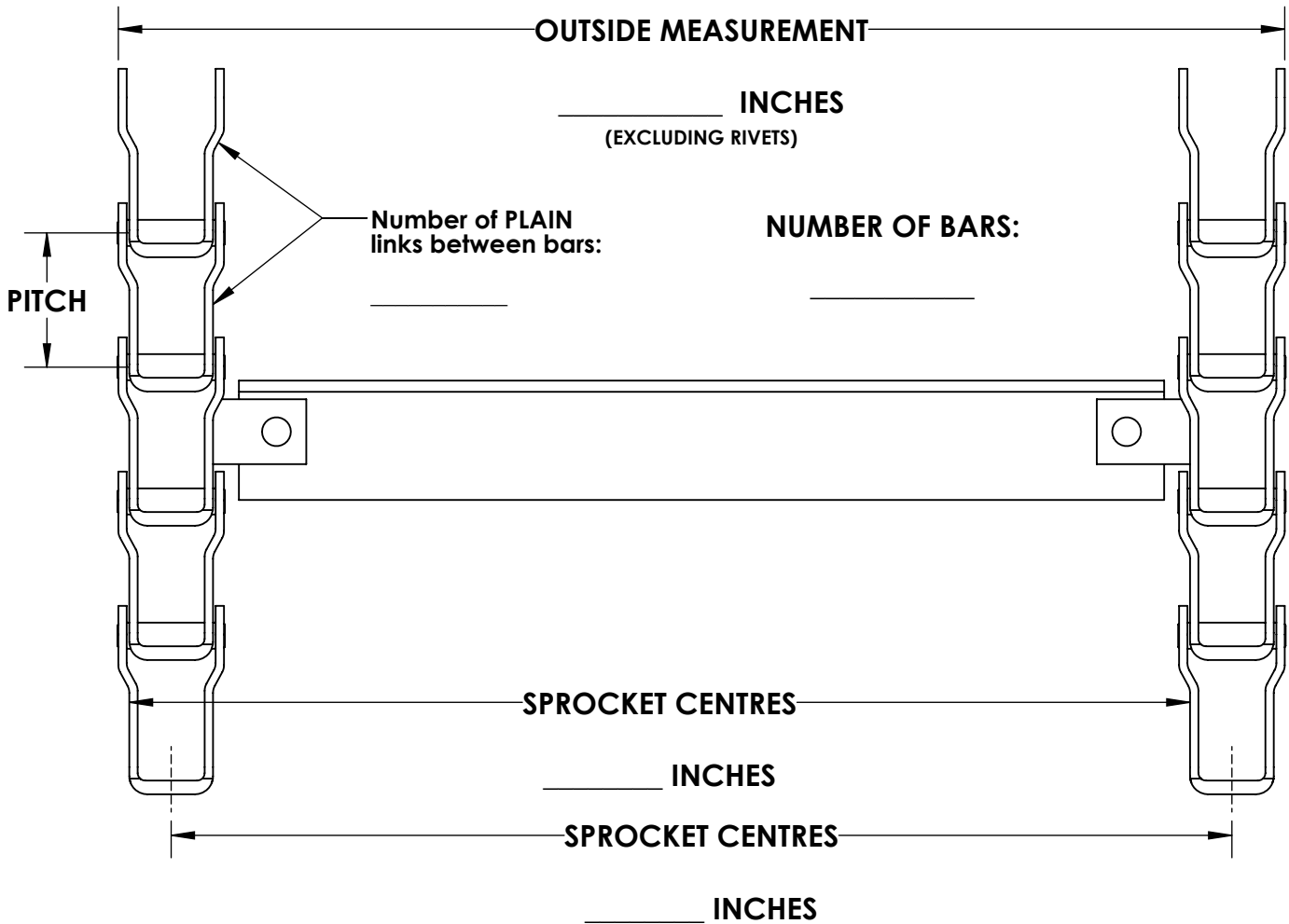

Manure Spreader Apron Chain Form



CHAIN TYPE: _____
(SEE BELOW REFERENCE)

TOTAL NUMBER OF LINKS PER STRAND: _____

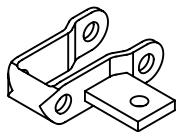

667X PINTLE CHAIN
PITCH - 2.250"

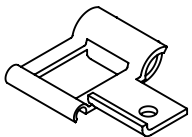

67XH FLAT DETACHABLE
PITCH - 2.313"

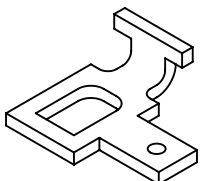

67 T-BAR DETACHABLE CHAIN
PITCH 2.550"

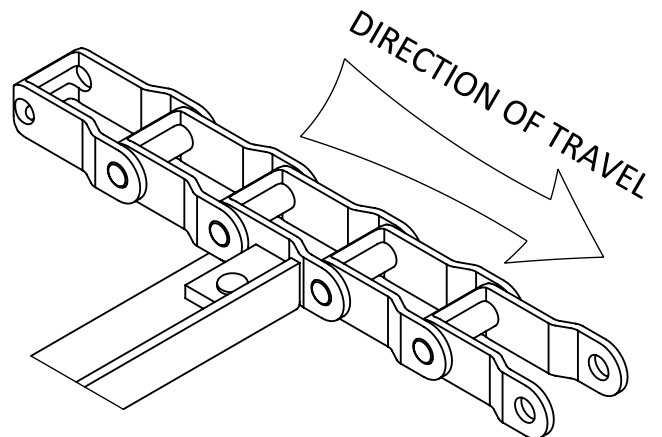

DIRECTION OF TRAVEL