



LINER

Rotary Rakes

CLAAS



LINER.





Product overview	4
Technology for professionals	8
Rotor dome assembly	10
Tine arms	12
User-friendly features	14
Road transport	16
Outstanding forage quality	18
Four-rotor rakes	22
LINER 4000 / 3600	24
Dual-rotor rakes (center delivery)	28
LINER 3100	30
LINER 2900 / 2800	32
LINER 2700 / 2600	34
Dual-rotor rakes (side delivery)	36
LINER 1900 / 1800 TWIN / 1700 TWIN	40
LINER 800 TWIN / 700 TWIN	46
Single-rotor rakes	48
LINER 500 T / 450 T / 370 T	50
CLAAS Service & Parts	52
Specifications	54

The ultimate in professional equipment – the four-rotor rake.

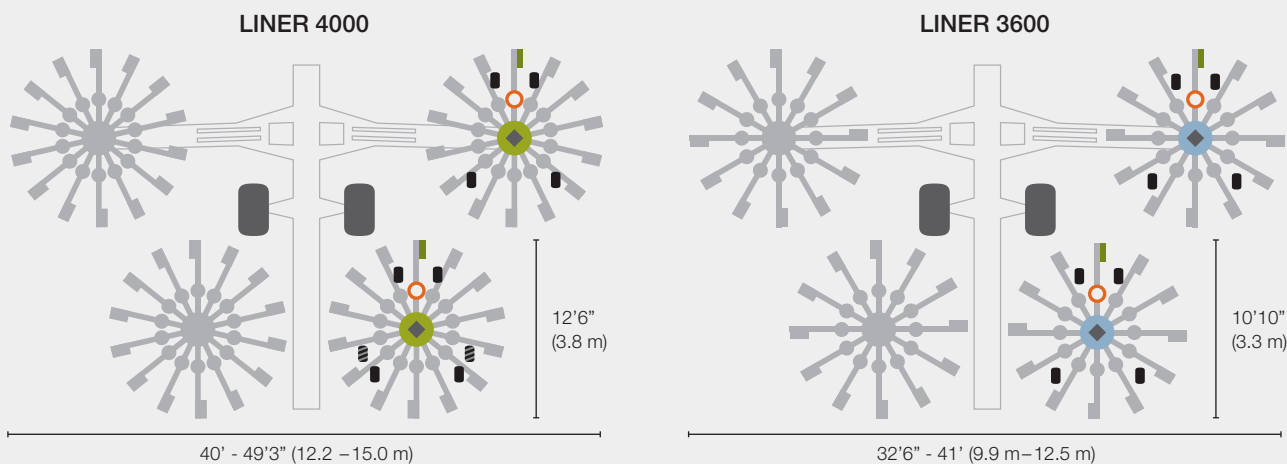

Tines

- Silage tines, 9.5 mm
- Standard tines, 9.0 mm

Tine arm attachment

- PROFIX/20-spline multiple gearing
- PROFIX/lemon profile
- Clamping cotter pins/lemon profile
- Tensioning pins/fixed connection

Rotor dome assembly

- 14-arm rotor dome assembly (permanently lubricated), with triple bearing
- 12 arm rotor dome assembly (permanently lubricated), with double bearing
- 11 arm rotor dome assembly (permanently lubricated)
- 8 arm rotor dome assembly (permanently lubricated)
- ◆ Cardanic suspension

Chassis

- Rotor chassis with 4 or 6 wheels:
- Standard
 - Option
- 1 TWIN = dual windrows possible
2 T = trailed

Width

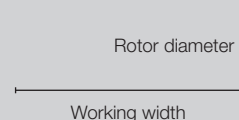

For the best results:
rake know-how from
CLAAS.

Sophisticated technology.

It goes without saying that our customers want to have the best machines to work with. CLAAS engineers devote all their efforts, every day, to make that happen. Our rakes are the most innovative on the market.

The crop harvest center of competence.

The crop harvesting product development center at the CLAAS plant in Bad Saulgau is one of the most modern and advanced facilities of its type in the world today. This location is right in the heart of Europe's largest territorial area of grassland, making the employees even more aware of the job at hand.

Versatile and multi-talented— the dual-rotor center-delivery rake.

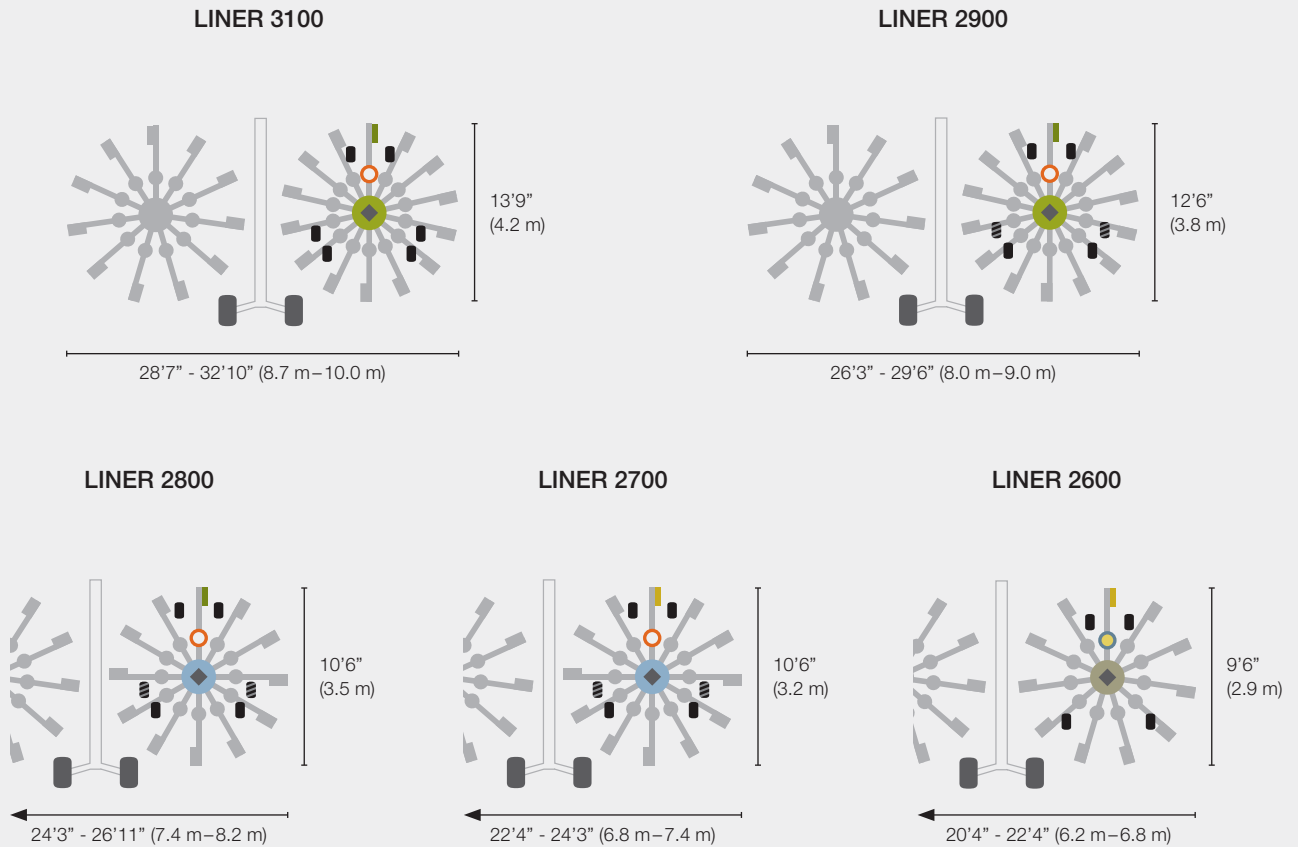

The best for the future, built on the best of the past.

Our customers are looking for versatile solutions that match their specific needs. Farms keep growing and changing, just as we are continuously developing our products. We retain the best of our existing technology, and keep improving everything else.

Team player in the harvest chain.

Conditions keep changing – so do people and harvesting processes. Continuous change places complex demands on machinery and equipment, which we meet with a powerful team of forage harvesting machines. One of our 15 LINER models will make an ideal member of your team.



CLAAS Saulgau GmbH is the company's nucleus of forage harvesting competence, with one of the most modern product development facilities anywhere in the world today.

The classic – dual-rotor rake with side delivery.

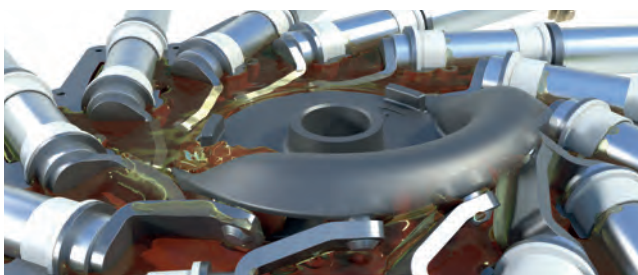
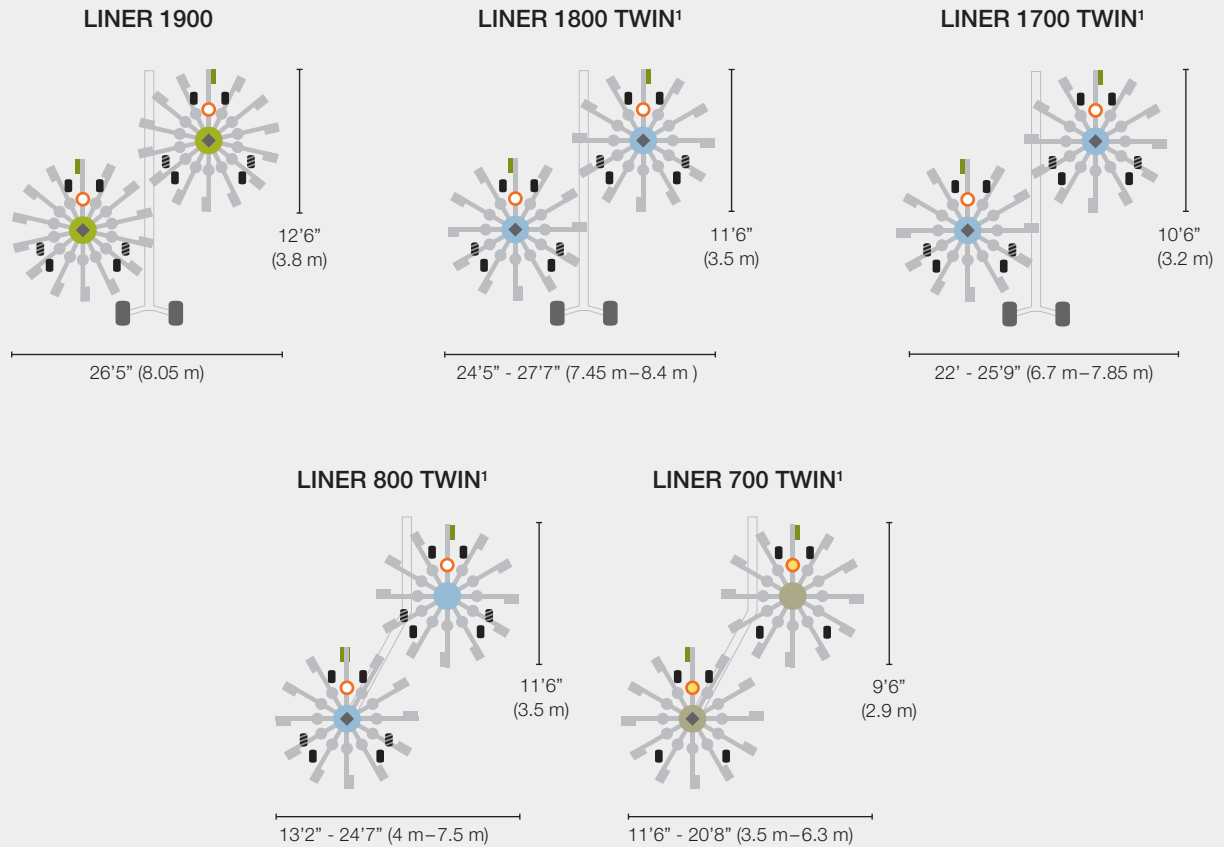

Cam track in oil bath: life-long maintenance-free reliability.



To keep the JAGUAR supplied with enough crop, in 1998 CLAAS introduced the world's first four-rotor rake, and now has two models with top productivity performance in the professional equipment segment.



Cardanic rotor suspension, ensuring rotors adjust to the ground contours independently from all tractor functions.



On-grip tines: the original robust and reliable performer, in all operating conditions.

Compact single-rotor rake.

LINER 370T²

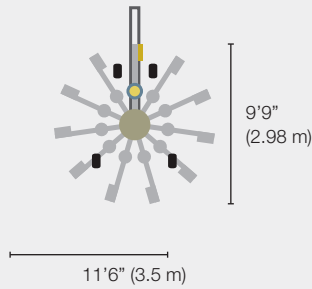

LINER 500 T²

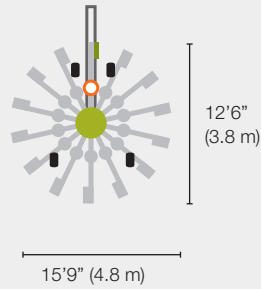

LINER 450 T²

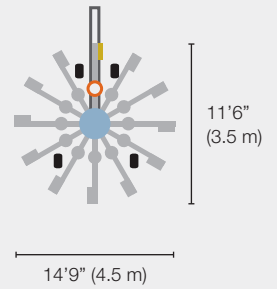

Tines

- Silage tines, 9.5 mm
- Standard tines, 9.0 mm

Tine arm attachment

- PROFIX/20-spline multiple gearing
- PROFIX/lemon profile
- Clamping cotter pins/lemon profile
- Tensioning pins/fixe connection

Rotor dome assembly

- 14-arm rotor dome assembly (permanently lubricated), with triple bearing
- 12 arm rotor dome assembly (permanently lubricated), with double bearing
- 11 arm rotor dome assembly (permanently lubricated)
- 8 arm rotor dome assembly (permanently lubricated)
- ◆ Cardanic suspension

Chassis

Rotor chassis with 4 or 6 wheels:

- Standard
- Option

- 1 TWIN = dual windrows possible
- 2 T = trailed

Width

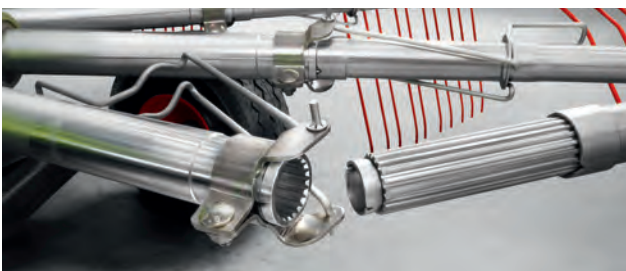
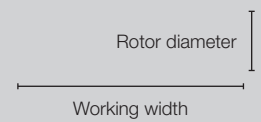

The patented PROFIX tine arm bracket with multiple gearing: easy and convenient tine arm fitting and removal.



The unique chassis design of the CLAAS side delivery rake allows lift heights of up to 28 in (70 cm).



In the event of a collision, the tine arms snap off at a set bending point, preventing any serious damage.



Tandem axle, for optimum tine position at even higher driving speeds.

Smooth operator.

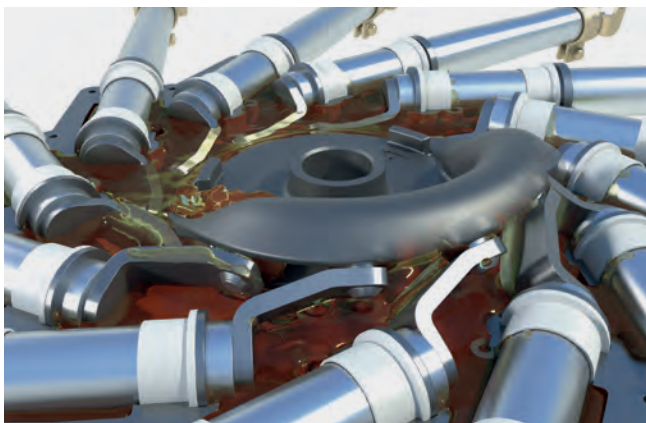
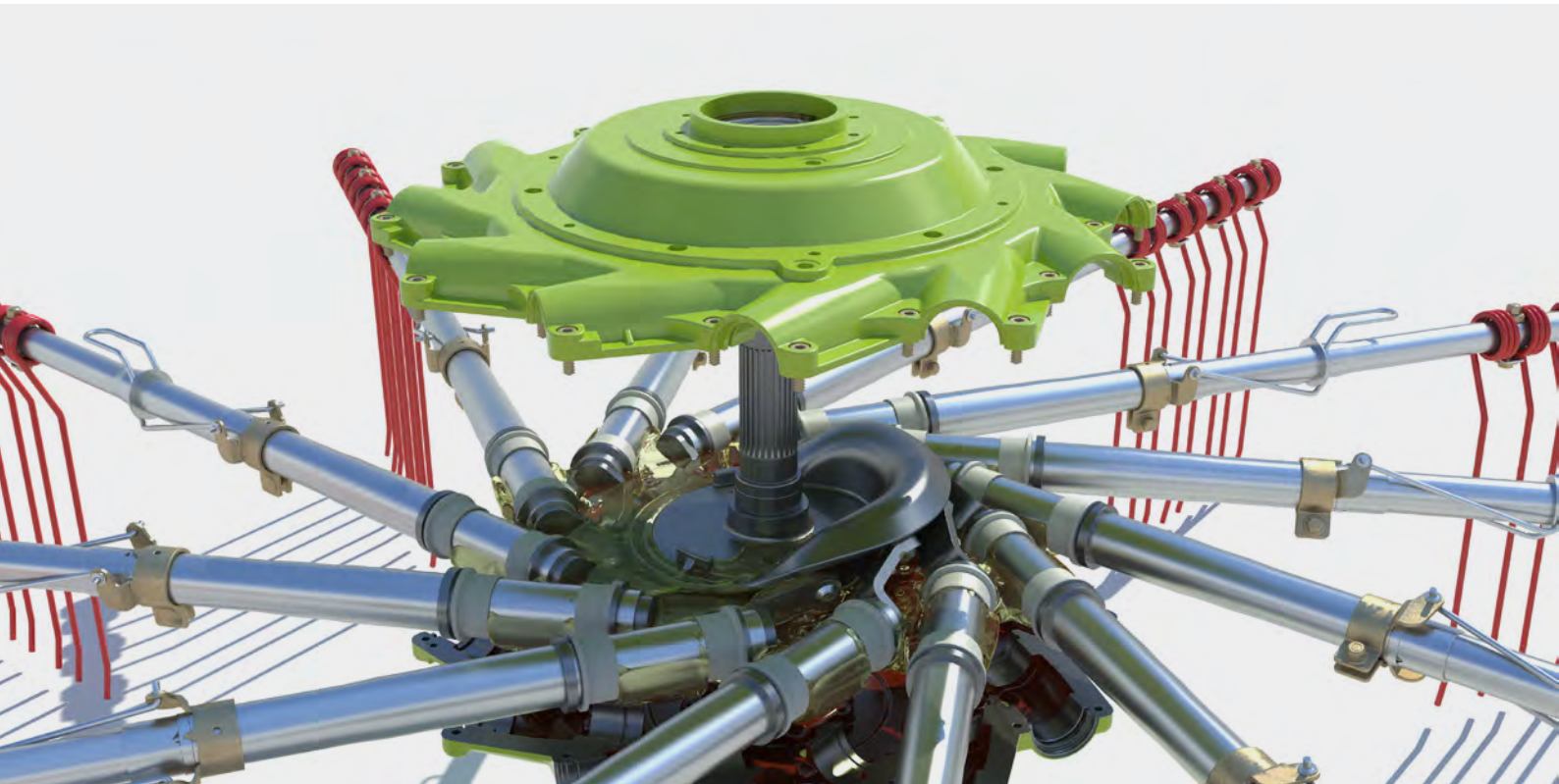

Continuously lubricated rotor dome assembly for professional operators.

The rake's transmission is located in a solid cast housing (rotor dome assembly), which is filled with oil and hermetically sealed. This means the core component of the LINER is protected from dirt entering, and is therefore maintenance-free. The cam rollers operate smoothly in an oil bath. This perfect frictionless operation guarantees maximum service life.

- Continuously lubricated, maintenance-free rotor dome assembly in all models
- Intelligent drive concept with individual rotor overload protection
- Robust and durable cam track, made of spheroidal graphite cast iron

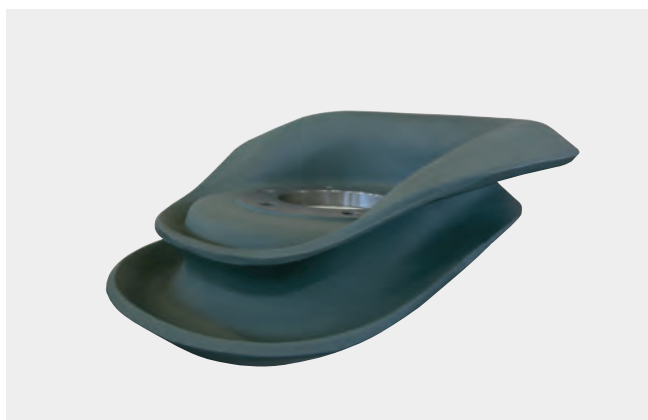

The CLAAS long-running cam track.

High performance under all conditions – its spheroidal graphite iron construction gives the cam track the strength required to withstand any load. The large diameter and the gentle rise of the cam track ensure that the thrust forces from the turning momentum are minimized. As a result, the tine arms operate smoothly, giving a clean raking action without material fatigue, even during periods of prolonged use.

Built to last.

The LINER's operating reliability and stamina make it an ideal part of the core forage harvesting team. To ensure clean raking results when they matter most, all machine parts are designed to meet the most rigorous requirements.

The cam track arms have a triple-bearing system in the 14 tine arm rotor dome assembly, and a dual-bearing arrangement in the 12 tine arm version. The plain bearings are generously dimensioned and wear-resistant. This reduces wear on the cam rollers, protecting them against both horizontal and vertical loadings.

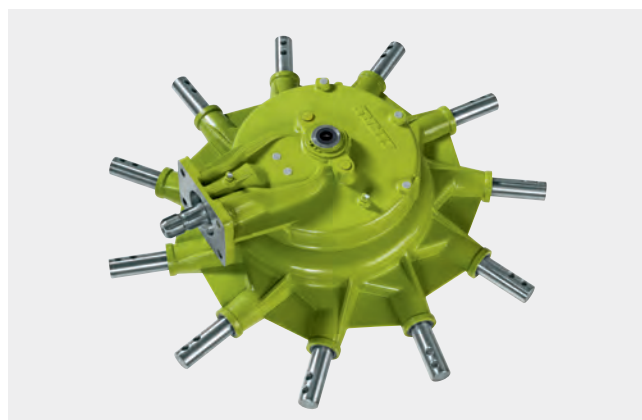

Compact: robust 11 or 8 arm rotor dome assembly.

Some of the small LINER models are fitted with a smaller rotor dome assembly. The steel cam rollers are continuously lubricated in an oil bath, with the robust cast housing hermetically sealed and maintenance-free. The tine arm brackets are secured to the cam track arms either by clamping cotter pins, or via a positive connection with a lemon profile.

The drive concept.

LINER rakes feature a highly reliable, entirely external drive train, ensuring ease of access. The main driving force is transferred to the rotors via an auxiliary gearbox with intelligent gear ratios. That means you are always working at optimum revolutions, which reduces fuel consumption and also protects the crop material. An integrated freewheel mechanism is fitted as standard, to protect the rotors against overload.

Low maintenance.

The LINER is an incredibly low-maintenance machine, with a 250 hr lubrication interval for the universal joints of the drive shafts, and a 50 hr interval for the travel drive shaft.

Better quality means better results.

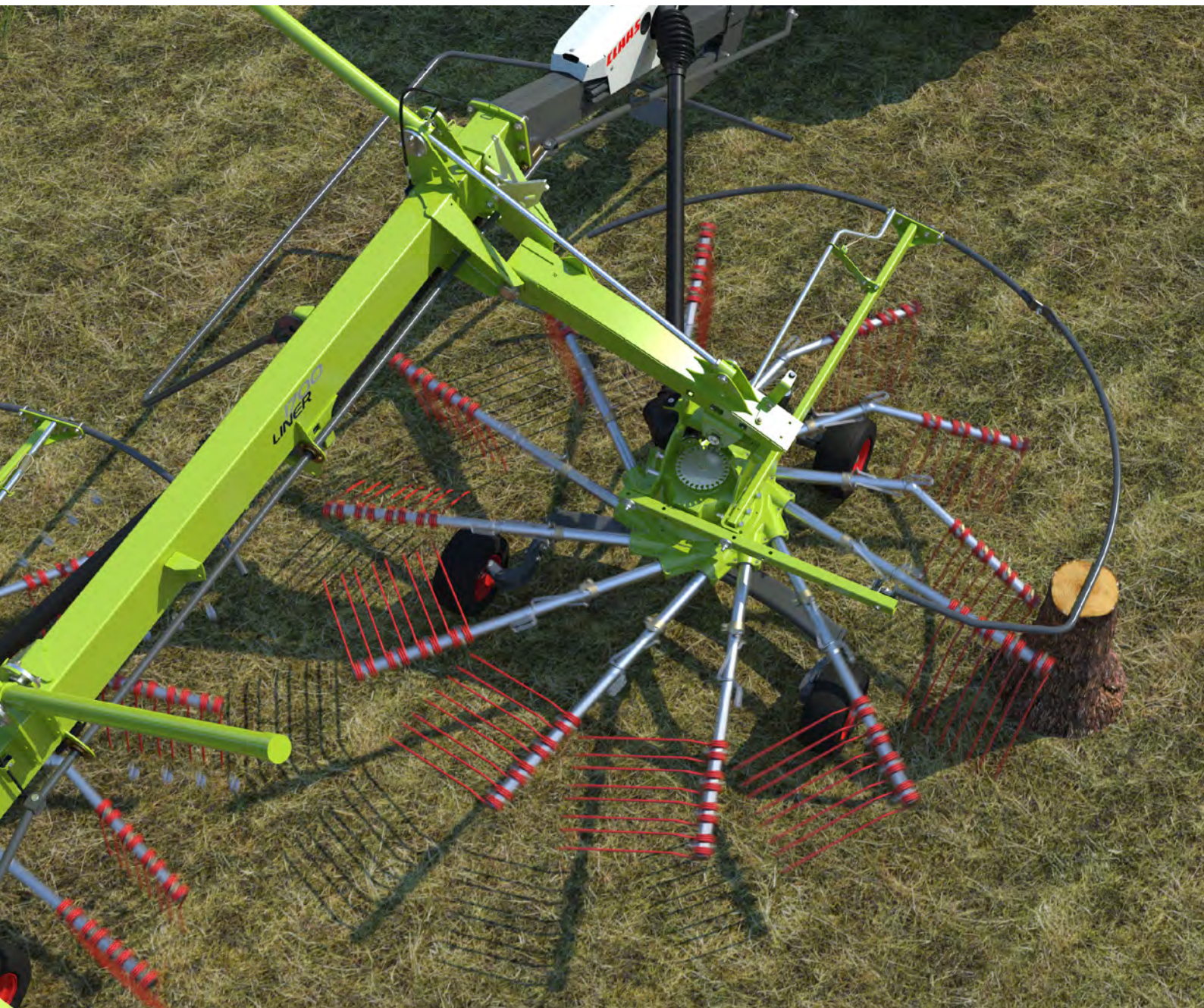

- Predefined bending points on all tine arms
- Faster tine arm replacement in the event of a collision, with the PROFIX attachment system
- Top-quality materials for maximum strength

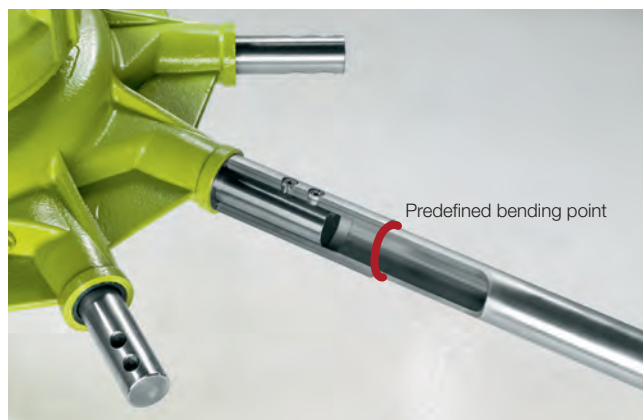
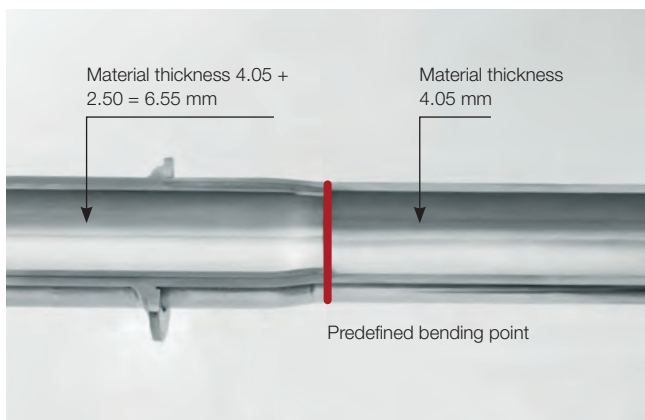

Patented PROFIX system.

In the event of a collision with an extraneous object, the tine arms deflect at a predefined bending point and are then easily replaced, thanks to the patented PROFIX bracket mounting. The bending points are located outside the rotor dome assembly, which therefore remains undamaged. All PROFIX tine arm attachment components can be replaced in a matter of moments, at minimum expense.

The 20 spline multiple gearing attachment keeps the tine arms firmly attached, with no play, and therefore no wear. The seating position is clearly indicated with marker arrows.

Predefined bending points in all models.

In the smaller 11 arm rotor dome assembly, the tine arms are attached with PROFIX, clamping splints or tensioning cotters, according to the model. In the 8 arm rotor dome assembly, clamping splints are used. In both rotor dome assemblies, in the event of a collision the tine arms deflect at a predefined bending point, and can be immediately replaced.

Strong arms for every rotor.

The generous tube diameter and wall material thickness make the tine arms extremely strong. The tine arm length varies according to the model, so the same type of rotor dome assembly can have different rotor diameters (see table).

Rotor diameter		
14 arm rotor dome assembly	12 arm rotor dome assembly	11 arm rotor dome assembly
13'9" or 12'6" (4.2 m or 3.8 m)	11'6" or 10'6" (3.5 m or 3.2 m)	9'6" (2.9 m)



Lemon profile attachment and PROFIX tine arm attachment system in the LINER 700 TWIN.



Lemon profile attachment and clamping splint in the LINER 370 T.

First work, then relax and enjoy yourself, they say – with the LINER you can do both at once.



- Clean windrow, thanks to step sequencing and maximum lift heights
- Narrow turning circle safe road transport
- Easy adjustment of working height and rake width



Adjustable hydraulic step sequencing.

When folding in the transport position, or raising in headland position, the rotors are raised parallel to the ground before being inclined inwards. This ensures that the finished windrow is not destroyed by any rotating tines. During lifting, the front rotors are lifted first, while during lowering, the rear chassis wheels are set down before the front ones, so that the tines cannot catch in the ground and the forage stays clean.

Unmatched lifting heights.

The maximum lifting height in headlands allows passage over even the largest windrows. So you can turn quickly, with no effect on the clean windrow.

Maximum maneuverability.

The maximum steering lock is marked on the drawbar. This is a great advantage in the field, and essential when negotiating narrow entrances, for example.

Flexible rake height and width.

Both working height and rake width are easily adjustable on all models. For optimum rake width adjustment, on the larger models, there is also a scale on the telescopic arms. The rake height can be read off the central shaft of the rotor chassis at any time, and adjusted as needed.



Maximum lift heights for clean windrows even in headlands.

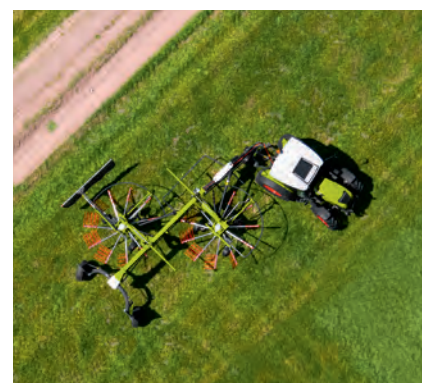

Dynamic handling, even in a tight space.



Keeping it flexible, with the rake height adjustment scale.

Convenience both on and off the road.



- Road transport height of less than 13'1" (4 m)
- Low center of gravity means excellent road stability
- Tidy cab conditions, with storage surfaces and holders for all cables and the drive shaft



For some models, the tine arms have to be removed for road transport – but they can be stowed away in no time at all.

Safe, compact and fast transport on the road.

Almost all models fold down to a transport height of less than 13'1" (4 m) without removal of the tine arms.

On two-rotor and four-rotor rakes, the rotors are folded up, and then hydraulically retracted from the tractor and mechanically or hydraulically secured for transport. This is both convenient for the user and extremely safe: the LINER low center of gravity ensures excellent on-road stability, even at road speeds of up to 31 mph (50 km/h).

In models with larger rotor diameters, the tine arms are quickly and easily removed, thanks to the PROFIX attachment system, and stowed in the tine arm brackets provided. For even greater safety, all LINER models are equipped with road lights standard.



All tidied away: the right solution for every model.

Clean and tidy.

The reliable and easy-to-use stand provides a convenient storage surface for the drive shaft. And depending on the model, there are also user-friendly holders for hydraulic hoses and cables. So the machine can be parked away neatly, out of harm's way.

Rotatable mounted hose holders avoid any strain on the connection with the tractor.

There is plenty of room around the drive, allowing a steering lock of up to 80°.

A clean feed crop, with no compromise.



- The cardanic rotor adapts effortlessly to uneven terrain
- Adjustable raking rotor angle
- Sturdy, flexible tines ensure clean pick-up of the crop
- Optimum ground-contour following protects both the soil and the crop
- Chassis stability on all types of terrain
- Optional gauge wheel, with tool-free adjustment (depending on the model)

Fully floating rotor suspension

For three-dimensional adaptation to uneven terrain, the rotors move both lengthwise and laterally across the direction of travel, independently of the position of the main frame.

Rotor adjustment – simplicity itself.

The rotors are set correctly when placed at the minimum angle towards the windrow. To adjust, select the appropriate insertion position on the main shaft of the rotor chassis to ensure complete pick-up of the crop material. The result is a perfect windrow, even when raking at high speeds.

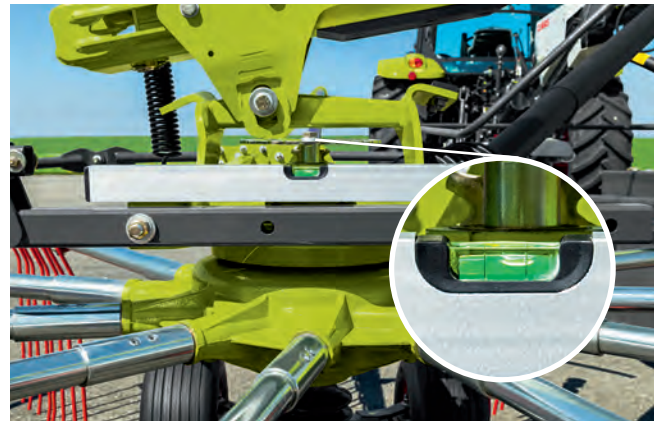

When the tine is right...

CLAAS silage tines achieve ideal, clean crop pickup, with a tine thickness of 0.37 in (9.5 mm) and an angle of 10° at the bottom of the tine. This ensures reliable on-grip operation in all operating conditions, thanks to continuous enhancement of the product design. CLAAS engineers thrive on this kind of challenge. It's not just about good ideas, but turning them into the best possible solutions. It's also about vision, seeing further than the edge of the next rotor!



Ideal weight distribution.

The high-volume tires on the main chassis give the LINER a wide track and a maximum contact area. This means that the weight is distributed optimally, and the soil is protected. The chassis provides the greatest possible stability on slopes, and on roads it enables high speeds.



The gauge wheel traces the ground contours.

The four-wheel or six-wheel chassis ensures optimum travel of the rake over the ground. The trailing-steered wheels on the front rotor and at the front of the rear rotor provide optimum soil protection. And the rigid wheels on the rear of the back rotor stabilise the LINER on hilly terrain.

For clean harvesting results over the entire working width, on both sloping and flat ground, the wheels are positioned close to the tine circle of rotation.



Four times optimum productivity –
as you'd expect from the ultimate professional.

Four-rotor rakes

With the four-rotor rakes, raking bottlenecks become a thing of the past. The LINER four-rotor rakes stand out from the rest because of their power, intelligence and reliability.

LINER 4000	40' - 49'3" (12.2 – 15.0)
LINER 3600	32'6" - 41' (9.9 – 12.5)





Unbeatable teamwork –
59 feet (18 meters) in a single pass.

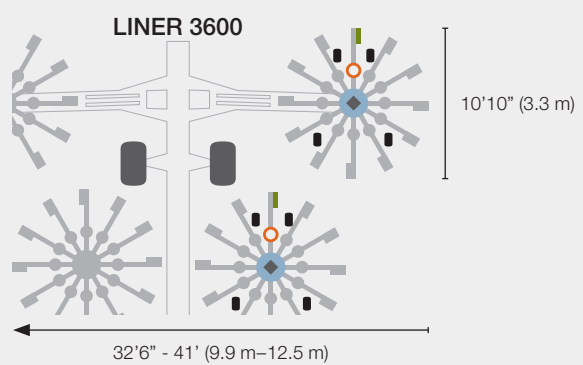
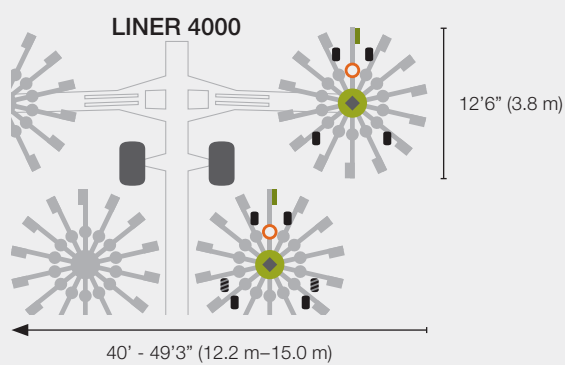



Peak production from combined forces, based on high working widths.

The recipe for a faster return on higher upfront investment costs is to have the right combination of machines working for you. Bigger working widths significantly reduce overlap between passes – which automatically boosts the productivity of your forage harvester or loading wagon.

59-to-39 mowing strategy with the DISCO 9200 C AUTOSWATHER.

With the DISCO 9200 C AUTOSWATHER, you can lay a working width of 59 ft to 39 ft 4 in (18.0 m on 12.0 m), using the machine's belt units. The crop is then formed into a single windrow with the LINER 3600. The result is 50% more grass in the windrow for the JAGUAR harvester following along behind.

Flexibility in the headland.

The benefits are self-evident:

- Adjustable time sequence for lifting and lowering of the front and rear rotor pairs
- Hydraulically adjustable, infinitely variable lift height at headlands to suit every type of forage crop
- Automatically folding swath guard for maximum ground clearance

<ul style="list-style-type: none"> ■ Silage tines, 9.5 mm ○ PROFIX/20-spline multiple gearing ■ Rotor chassis with 4 or 6 wheels: ■ Standard ▨ Option 	<ul style="list-style-type: none"> ● 14-arm rotor dome assembly (permanently lubricated), with triple bearing ● 12-arm rotor dome assembly (permanently lubricated), with double bearing ◆ Cardanic suspension
--	---

Rotor diameter

Working width



Outstanding results –
see for yourself.



It couldn't be gentler.

Customizable chassis: ideal ground protection is assured, thanks to the four-wheel rotor chassis with steered front wheels and a laterally suspended front axle, or the six-wheel rotor chassis for the rear pair of rotors with additional tandem axle and trailing wheels, available as an option with the LINER 4000.

- GRASS CARE: optimal ground-contour following, including at high working speeds, guarantees clean forage
- Powerful spring packs cushion the rotors
- Suspended mounting of the rotor chassis front axle for precise rotor guidance
- Large 500/50-20 or 620/40 R 22.5 road tires for optimum ground protection and maximum stability during transportation



Comfortable to operate.

The LINER 4000 and 3600 feature comfort hydraulics as standard. Both models are operated via the OPERATOR, the COMMUNICATOR II, EASY on board, or any other ISOBUS-capable terminal. ISOBUS operation allows various functions to be assigned to the tractor's spool valves, providing additional support for the driver in the form of numerous automated processes.

- Convenient folding in and out from inside the cab
- Infinitely variable hydraulic adjustment of windrow and working width
- Different parameters can be determined and stored to match the particular operating conditions (such as different windrow widths and raking heights)
- Overview of all the services provided and customer data in conjunction with the hectare counter
- Performance optimisation with steering systems
- Low fuel consumption
- More acres per hour, from full use of working width capacity



LEDs – so you're never left in the dark.

Even when you need to work well into the night, you'll always enjoy all-round visibility. Perfect lighting is provided by a total of three optional LED work lights (two for the front rotors and one for the windrow). The special light assists the driver by provided maximum contrast, yet without dazzle, ensuring optimal illumination around the rake. The work lights are activated automatically along with the tractor lights in darkness.

Windrow width adjustable according to the conditions.

In the LINER 3600, the windrow width is adjusted mechanically with a grip, while the LINER 4000 has user-friendly hydraulic adjustment from the terminal, accommodating the crop mass characteristics and all widely used pick-ups, from 47 in to 102 in (1.2 to 2.6 m).

Less than 13'1" (4 m) without removing tine arms.

The hydraulically lowered transport chassis reduces the transport height of both models to less than 13'1" (4 m), without removing the tine arms (with 22.5" tires for the LINER 3600).

Best in class –
the power of two.





Dual-rotor rakes (center delivery)

The reliable alternative to the four-rotor rake should be used when flexibility is called for in addition to a high work rate. Whether working with silage, hay or straw, the LINER dual-rotor rake with central windrowing, and working widths of between 20'4" and 32'10" (6.2 and 10 m), is unmatched in its class.

LINER 3100	28' 7" - 32'10" (8.7 – 10 m)
LINER 2900	26'3" - 29'6" (8 – 9 m)
LINER 2800	24'3" - 26'11" (7.4 – 8.2 m)
LINER 2700	22'4" - 24'3" (6.8 – 7.4 m)
LINER 2600	20'4" - 22'4" (6.2 – 6.8 m)

Your trusted specialist –
and not just in straw.



LINER 3100

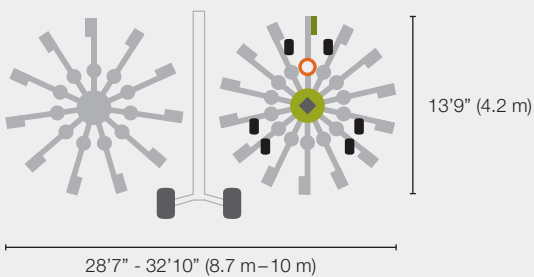

- Silage tines, 0.37" (9.5 mm)
 - PROFIX/20-spline multiple gearing
 - Rotor chassis
 - 14-arm rotor dome assembly (permanently lubricated), with triple bearing
 - ◆ Cardanic rotor chassis connection
- Rotor diameter
Working width

Power and efficiency with two rotors.

With a working width of between 28'7" and 32'10" (8.7 and 10 m), the LINER 3100 can be reliably deployed anywhere. This can be infinitely varied by means of hydraulics, and can be read off on a scale. When working in straw, thanks to its generous working width, the LINER 3100 is easily able to combine two windrows from a 24'6" (7.5 m) harvester cutterbar.

Large rotor to cope with even the thickest windrows.

With a rotor diameter of up to 13'9" (4.2 m), a total of 14 PROFIX tine arms, each with five double tines, ensure that

nothing is left behind. And with a lift height of up to 35'6" (90 cm), the LINER 3100 can drive effortlessly over even the largest straw windrows. It can be adapted to all harvesting conditions via infinitely variable headland stops. At headlands, the windrow guard automatically folds upwards, giving maximum clearance.

User-friendly options through flexible control.

The single-rotor lifting function can be controlled without a terminal via a three-way valve.



Time savings and enhanced safety on the road.

To get the transport height down to below 13'1" (4 m), three tine arms are removed from each rotor, and securely attached to the holder provided for the purpose, directly on the rotor.



Ideal for tight curves: the steering system.

As the tractor is steered, the action is passed to the large wheels fitted to the main chassis via the hitching, transfer lever and steering linkage.

The time saver –
efficient, tidy, consistently successful.



Consistent, uniform raking with the LINER.

The LINER 2900 and 2800 have a successful record dating back many years. They consistently provide a perfectly formed windrow that is cleanly picked up with the follow-up machines. The windrow width is hydraulically adjusted according to the operating conditions, via a double-acting spool valve.

To adjust to a wide range of forage crops, the headland stop is infinitely variable in the two larger models. The swath guard, which can be folded automatically by means of hydraulics, ensures the maximum possible ground clearance.

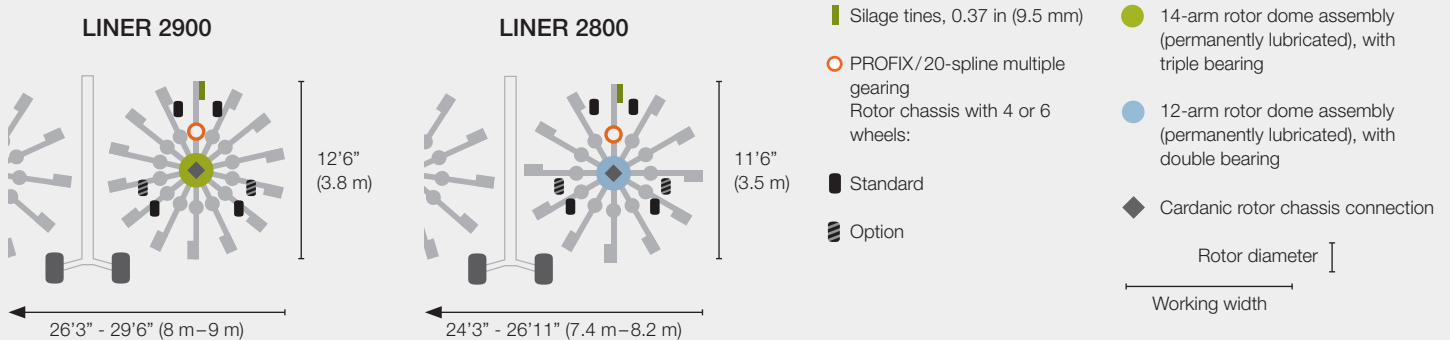



LINER 2900

The LINER 2900, with its 14 PROFIX tine arms, is the ultimate performer and the true silage professional. Contractors therefore like to use it ahead of a forage harvester. And for use with straw, the box-shaped windrows are ideal for producing well-formed bales.



LINER 2800

The LINER 2800 is a slightly smaller machine, more popular with farmers. Its 12 tine arms also deliver tidy and reliable raking results, but with a more compact windrow, with a maximum of 7'3" (2.2 m).



Optimum ground-contour following.

Both models can be supplied on request with a six-wheel rotor chassis and additional tandem axles, and trailing-steered wheels.

Efficient control system.

The single rotor lifting function can be controlled via a three-way valve.

Convenient transport.

All models fold down to a transport height of less than 13'1" (4 m), with hydraulic retraction of the rotors. And the automatic transport lock function makes the operation particularly convenient for the user.

Small farms –
they also face big challenges in the field.

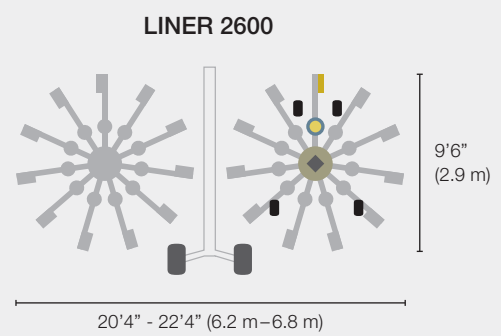
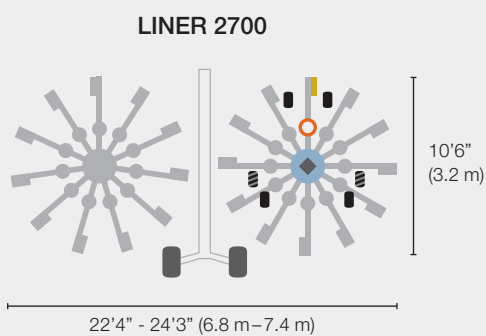

Stability.

The strong frame structure and large tires result in maximum stability. In all models, the wheels of the frame are controlled by active steering. The benefits include flawless trailing and optimum adaptation to the tractor position.



Powerful and flexible.

The two small central delivery models are also highly versatile performers. The windrow width is mechanically adjustable according to the operating conditions.

The rotors are secured with a mechanical locking system for road transport.

LINER 2700

Like its larger counterparts in the central delivery segment, the LINER 2700 is fitted with the PROFIX tine arm attachment system. With a maximum windrow width of 6'7" (2 m), it is ideal for farms that organize their own baling or loading operations.

LINER 2600

Unbeatable price-performance ratio. The LINER 2600 has everything a rake needs – including a maintenance-free, hermetically rotor dome assembly, permanently filled with oil.

The LINER 2600, with a maximum windrow width of 5'11" (1.8 m), is particularly impressive in haymaking operations.

- Standard tines, 9 mm
 - PROFIX / 20-spline multiple gearing
 - Clamping cotter pins/lemon profile
 - Rotor chassis with 4 or 6 wheels:
 - Standard
 - ▨ Option
 - 12-arm rotor dome assembly (permanently lubricated), with double bearing
 - 11-arm rotor dome assembly (permanently lubricated)
 - ◆ Cardanic rotor connection
- Rotor diameter |

Working width

The bigger the family –
the wider the range of skills and talents.

New arrivals in the side delivery rake range.

We've added three models to the product range. The dual-rotor rakes with side delivery and three-dimensional rotor frame guarantee meticulous raking in all situations.

LINER 1900	26'5" (8.05 m)
LINER 1800 TWIN	24'5" - 27'7" (7.45 m – 8.4 m)
LINER 1700 TWIN	22' - 25'9" (6.7 m – 7.85 m)
LINER 800 TWIN	13'2" - 24'7" (4 – 7.5 m)
LINER 700 TWIN	11'6" - 20'8" (3.5 – 6.3 m)





Sometimes the best way to lead is to follow – when it comes to ground contours, for example.



"Inferior feed equals poor quality livestock."

High-quality forage is the key to success. That means choosing the best time for harvesting, and then handling the crop correctly. This starts with the ground-contour following, because our farmers can achieve their targets only if the harvesting machines produce a clean crop:

- Low foreign material content in stock feed, for sustainably healthy, productive animals.
- Consistently high-value mix of grass and herb species, thanks to protection of the windrow.



For superior raking: trailed cardanic suspension.

The innovative rotor suspension on a stable ball coupling mount allows both lateral and longitudinal rotor oscillation, independently of the main frame. The combination of maximum oscillation travel and outstanding stability provides optimum rotor adaptation to even deep ruts and bumps. As a result, the new LINER generation delivers superior raking outcomes, all the time, in any conditions.



Annette Jilg works in the Crop Farming and Feed Storage extension of the Baden-Württemberg Agricultural Center for Cattle, Crop, Dairy and Deer Farming and Fisheries in Aulendorf, and knows just how important a low foreign material content is for high feed quality.



New arrivals –
at the top end of the family.

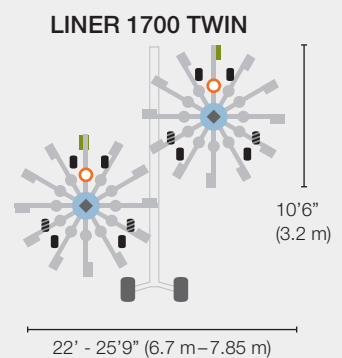
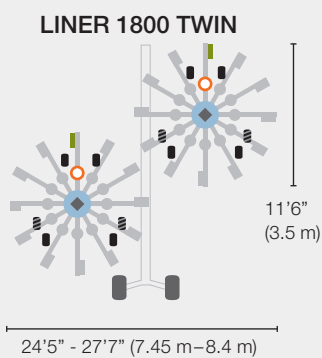
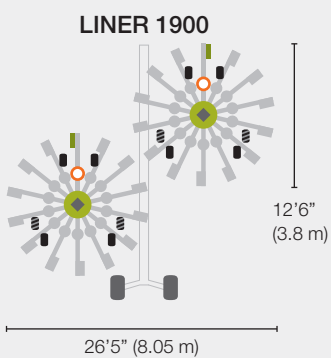



LINER 1900.

The LINER 1900, with working width of 26'5" (8.05 m) and rotor diameter of 12'6" (3.8 m), is the largest, highest-performance side delivery rake. It is ideal for all professional silage businesses and farm contractors. By combining two windrows, material from a working width of up to 42'6" (16 m) can easily be formed into a single forage windrow. To avoid forage losses, the rotor overlap is infinitely adjustable from the driver's seat in the tractor. The four-wheel rotor chassis with steered front wheels and a laterally oscillating front axle ensures exceptionally smooth running and exact gauging of the ground contour, on any kind of terrain. On request, the LINER 1900 can be supplied with a six-wheel rotor chassis with additional tandem axles and trailing wheels, for even better ground-contour following, high work speeds and top forage quality.

A brief digression: full LINER dual-rotor range, and standardised model naming conventions.

As is already the case for dual-rotor rakes with central windrow delivery, dual-rotor side discharge rakes now also come with different rotor diameters. The second digit of the model number is always the same for a particular rotor diameter, and the first digit also provides essential information: 2000 models are central windrow delivery, while 1000 models have side discharge.

- Silage tines, 9.5 mm
- PROFIX/20-spline multiple gearing
- Rotor chassis with 4 or 6 wheels:
- Standard
- ▨ Option
- 14-arm rotor dome assembly (permanently lubricated), with triple bearing
- 12-arm rotor dome assembly (permanently lubricated), with double bearing
- ◆ Cardanic rotor connection

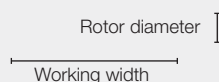

LINER with side delivery	LINER with central delivery	Rotor diameter
1900	2900	12'6" (3.80 m)
1800 TWIN	2800	11'6" (3.50 m)
1700 TWIN	2700	10'6" (3.20 m)

NEW

Reliable partners –
professionalism guaranteed.

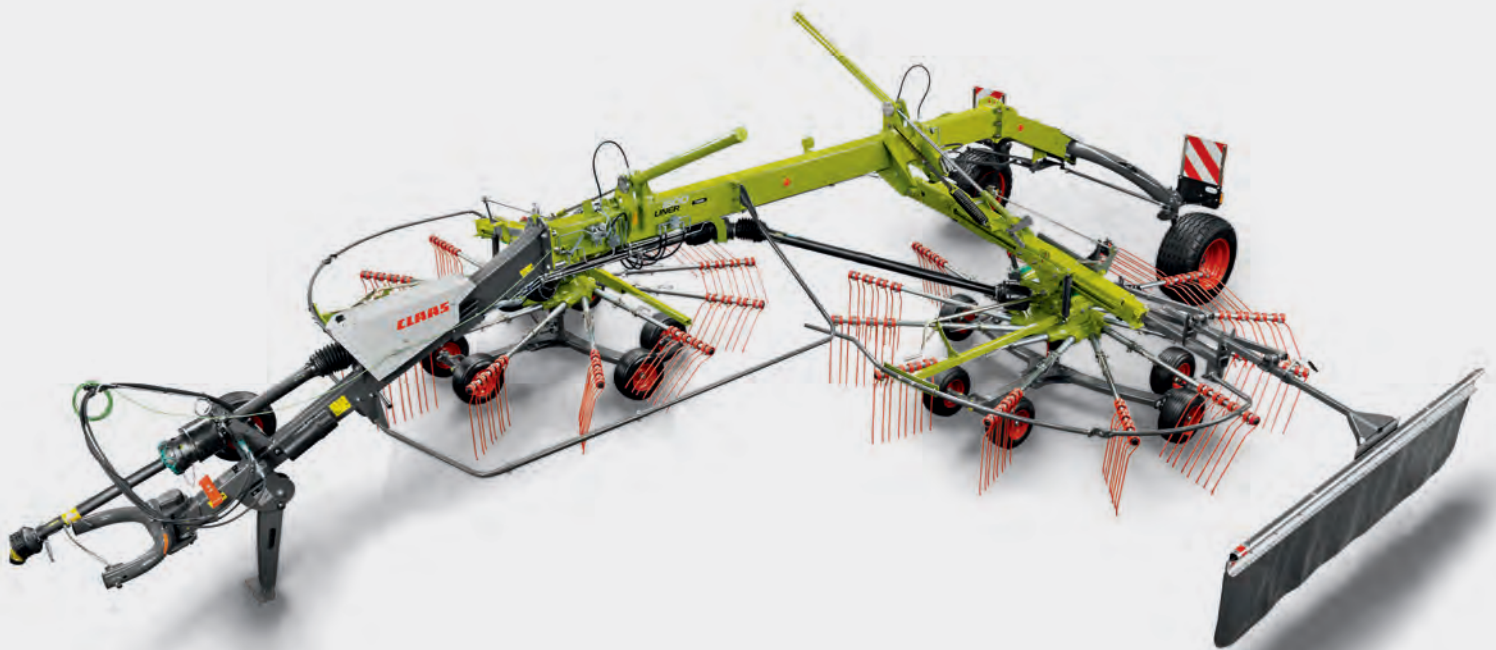



LINER 1800 TWIN and 1700 TWIN. Flexibility guaranteed.

The TWIN function allows flexible adaptability to a range of different conditions. The two individual windrows can be combined to form a large windrow for a forage harvester or baler. You also have the option of forming two smaller windrows for overnight raking, round balers or large forage volumes.

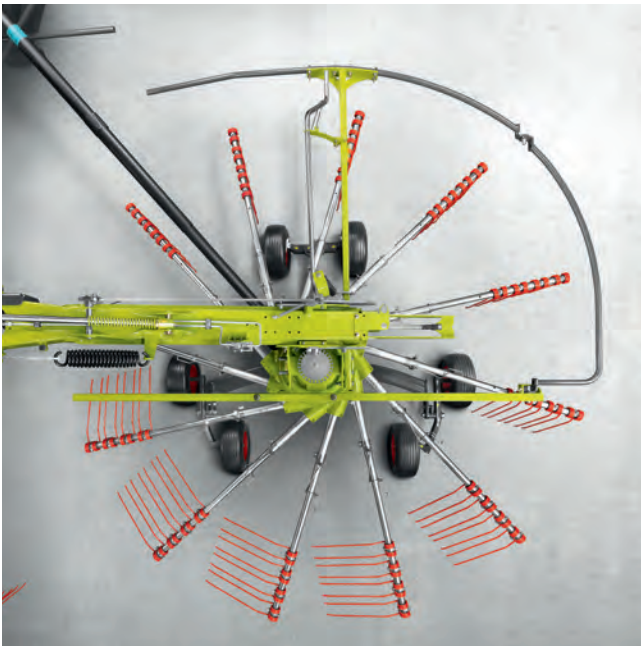

Hydraulic headland stops.

The LINER 1900 and 1800 TWIN models are equipped with an infinitely adjustable hydraulic headland stop. In the LINER 1700 TWIN, this function is performed mechanically, with two positions. The headland stop allows adaption to an incredibly wide range of crop conditions.



Changeover from single to double windrow discharge.

The telescopic booms of the LINER 1800 TWIN and 1700 TWIN provide a choice between single and double windrow discharge, simply by relocating the stop bolts.

Reliable, safe, low-maintenance – in each and every detail.



Impeccably shaped windrows.

Optimum windrow formation even in the headland, thanks to unparalleled lift heights of 20" (50 cm) for the LINER 1900 and LINER 1800 TWIN, 21" (53 cm) for the LINER 1700 TWIN. Even greater lift heights can be set for double windrow discharge.



Rotor manipulation for zero soiling.

Crop soiling effectively prevented with perfectly controlled rotor lift and lowering, also eliminating any risk of damage to the windrow.



Controlled lift and lowering.

Adjustable hydraulic sequence valve for time-delayed lifting and lowering of the rotors. The lift and lowering speed can also be adjusted to the tractor's hydraulic system.



Proven, low-maintenance LINER reliability.

The large-size tires (up to 340/55 R 16) protect soil and windrow – whether you opt for a four-wheel chassis, or the six-wheel chassis optionally available for the larger models.

External drive train and individually secured rotors, low maintenance, thanks to the 250 hr lubrication interval for the universal joints of the drive shafts.



TWIN function.

With the TWIN models, an additional windrow guard can be used to rake a double windrow (or windrows for smaller machines). At haymaking time, for example, this protects already dry material from exposure to moisture at night, before it can be collected.

Maximum maneuverability through flexible inverted U-frame hitch.

The flexible inverted U-frame hitch with lateral oscillation allows a steering lock angle of up to 80°. An easy-to-read scale is provided for adjusting the rake height on both of the rotor chassis.

Unlimited possibilities, taking the toil out of working.



LINER 800 TWIN

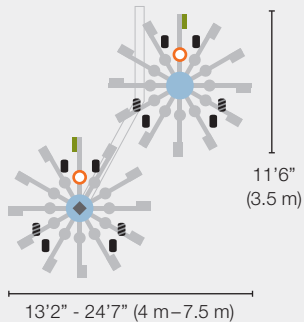

LINER 700 TWIN

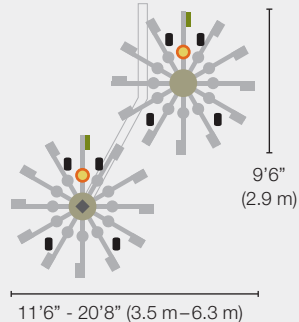

- Silage tines, 0.37 in (9.5 mm)
- PROFIX/20 spline multiple gearing
- PROFIX/lemon profile

Rotor chassis with 4 or 6 wheels:

- Standard
- Option

- 12 arm rotor dome assembly (permanently lubricated), with double bearing
- 11 arm rotor dome assembly (permanently lubricated)
- Cardanic suspension

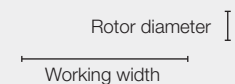



Efficient, high-performance raking.

The LINER 800 TWIN and 700 TWIN are the ideal harvest partners for small- and medium-sized farms whose operators want to rely on efficiency at a reasonable price. The impressive features of the rakes include their flexible working widths, low power requirements, high operator convenience and exceptional raking quality. Thanks to their large chassis and low center of gravity, both models are extremely stable on slopes and gentle on the soil in all types of conditions.

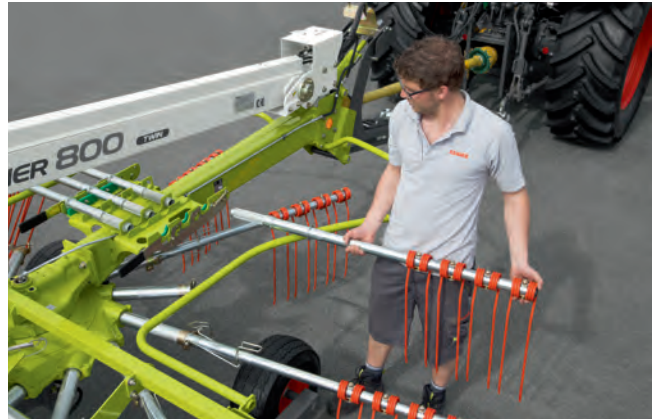

On the road.

The LINER 700 TWIN has a transport width of less than 9'10" (3 m) without removing the tine arms. In the LINER 800 TWIN, the rotor diameter is 11'6" (3.5 m), so the tine arms can be directly and conveniently secured on the rotor for transport purposes.



Generous lifting height for driving over windrows at headlands: up to 24 in (60 cm) in the LINER 700 TWIN

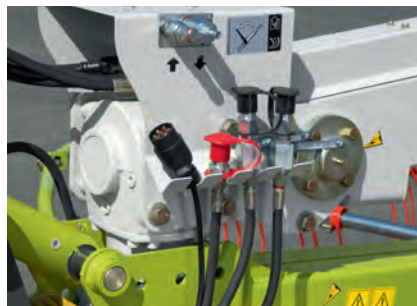

Hydraulic sequential control fitted as standard to adjust the time delay between front and rear rotors when raising and lowering



Parallelogram drawbar is standard in the LINER 700 TWIN and LINER 800 TWIN

Just one rotor, but plenty of performance.

Single-rotor rakes

The LINER single-rotor rakes are mainly intended for use in smaller fields. Working widths of 11'6" to 15'9" (3.5 to 4.8 m) are ideal for these situations. The key features of the LINER single-rotor rakes are precise ground-contour following, high work rates and excellent reliability.

LINER 500 T	15'9" (4.8 m)
LINER 450 T	14'9" (4.5 m)
LINER 370 T	11'6" (3.5 m)





Power to the rear –
the trailed models.



LINER 500 T

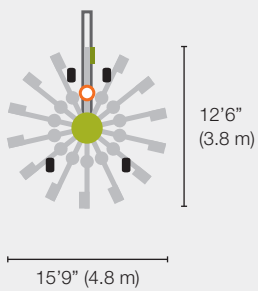

LINER 450 T

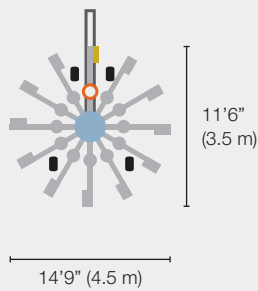

LINER 370 T

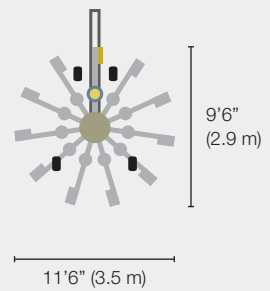

The “T” is for trailed.

With working widths of between 11’6” to 15’9” (3.5 to 4.8 m), the CLAAS trailed rakes follow effortlessly behind the tractor, even over sloping terrain. Once hitched up, the wide-track machine stays in line behind the tractor both in the field and on the road.

Runs like clockwork.

CLAAS relies on the continuously lubricated and hermetically sealed CLAAS rotor housing. All models (except LINER 370 T) are equipped with the PROFIX tine arm bracket and multiple gearing. For the LINER 370 T, the tine arms are connected to the rotor housing with a lemon profile.

All bumps smoothed out.

The CLAAS contour chassis with V-shape tandem axle is positioned close to the tines and adapts to uneven ground. The configurable lateral tilt enables the machine to adjust to different crop volumes. With its caster guide wheel, the rake glides over any uneven surface, ensuring it can operate with minimal loss and deliver an outstanding crop quality.

Off you go – no fuss.

Just one single-acting spool valve is required to operate the trailed single-rotor rakes.

- The hitch design enables raising of the rotors parallel to the ground
- Setting of rotor angle in the direction of travel via a built-in crank handle fitted in the drawbar cylinder
- Parallelogram drawbar for connection to rigid pulling mechanisms



- Silage tines, 0.37 in (9.5 mm)
- Standard tines, 0.35 in (9 mm)
- PROFIX/20-spline multiple gearing
- Clamping cotter pins/lemon profile
- Rotor chassis
- 14-arm rotor dome assembly (permanently lubricated), with triple bearing
- 12-arm rotor dome assembly (permanently lubricated), with double bearing
- 11 arm rotor dome assembly (permanently lubricated)

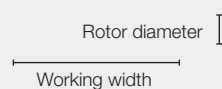

Whatever it takes – CLAAS Service & Parts.



Your needs matter.

You can always rely on us: we'll be there whenever you need us – everywhere, quickly and reliably, around the clock if necessary, with precisely the solution that your machine or business requires.

Reliability can be planned.

With our service products, you can increase your machine reliability, minimize your risk of breakdowns, and budget with confidence. CLAAS MAXI CARE offers planned reliability for your machine.



Always up to date.

CLAAS dealer service teams are trained by CLAAS and equipped with the all-important special tools and diagnostic systems to meet all your expectations with regard to expertise and reliability.

Problem solving by remote diagnostics:
CLAAS TELEMATICS.

CLAAS TELEMATICS on your machine brings two important advantages: fast assistance from CLAAS service technicians and a more profitable operation, thanks to wireless networking. We can be there, on the spot, to solve your problem – even when you can't see us.

ON YOUR FARM PARTS.

CLAAS ON YOUR FARM PARTS allows you to customize a selection of parts on your farm in order to get you back up and running in minimal time. Buy now – pay after the harvest – it's that simple. Ask your participating dealer for details.



ORIGINAL parts and accessories.

Specially matched to your machine: precision-manufactured parts, high-quality consumables and useful accessories. We will supply exactly the right solution from our comprehensive product range to ensure that your machine is 100% reliable.

Worldwide coverage from Columbus, Regina, and Hamm.

The CLAAS of America Parts Logistics Centers in Columbus, Indiana and Regina, Saskatchewan, provide world-class parts support throughout North America for all CLAAS products. Supported by the CLAAS worldwide spare parts depot in Hamm, Germany, we provide the CLAAS dealer network with reliable, consistent parts availability and industry leading responsiveness. Your local CLAAS dealer can supply the right parts solution for your business to maximize machine uptime.



The CLAAS Parts Logistics Center in Columbus, Indiana, stocks more than 36,000 part numbers in a warehouse area of over 165,000 sq ft.



The CLAAS Parts Logistics Center in Regina Saskatchewan, stocks more than 14,000 part numbers in a warehouse area of over 33,000 sq ft.

LINER center delivery rakes		4000	3600	3100	2900	2800	2700	2600
-----------------------------	--	------	------	------	------	------	------	------

Mounting category		Four-rotor rakes		Dual-rotor rakes				
		Cat. III	Cat. II	Cat. II	Cat. II	Cat. II	Cat. II	Cat. II
Working width	ft (m) (DIN)	40' - 49'3" (12.2 - 15)	32'6" - 41' (9.9 - 12.5)	28'7" - 32'10" (8.7 - 10)	26'3" - 29'6" (8 - 9)	24'3" - 26'11" (7.4 - 8.2)	22'4" - 24'3" (6.8 - 7.4)	20'4" - 22'4" (6.2 - 6.8)
Windrow width ^{ca.}	in (m)	59" - 102" (1.5 - 2.6)	47" - 90" (1.2 - 2.3)	59" - 102" (1.5 - 2.6)	47" - 94" (1.2 - 2.4)	47" - 86" (1.2 - 2.2)	47" - 79" (1.2 - 2)	43" - 71" (1.1 - 1.8)
Transport width with tine arms attached	ft (m)	9'10" (3)	9'10" (3)	9'9" (2.97)	9'9" (2.97)	9'9" (2.97)	9'9" (2.97)	9'9" (2.97)
Transport height with tine arms attached	ft (m)	13'1" (3.99)	13'1" (3.99) ¹	14'8" (4.46)	13'1" (3.99)	13'1" (3.99)	13'1" (3.99)	13'1" (3.99)
with tine arms removed	ft (m)	11'8" (3.57)	11'2" (3.4)	12'4" (3.75)	12'3" (3.72)	11'5" (3.47)	11' (3.38)	10'5" (3.18)
Parking length (transport position)	ft (m)	33'4" (10.16)	28'7" (8.7)	22'8" (6.92)	21'5" (6.53)	21'5" (6.53)	19'3" (5.87)	19'3" (5.87)
Rotors	Qty	4	4	2	2	2	2	2
Rotor diameter	ft (m)	12'6" (3.8)	10'10" (3.3)	13'9" (4.2)	12'6" (3.8)	11'6" (3.5)	10'6" (3.2)	9'6" (2.9)
Tine arms per rotor set	Qty	14	12	14	14	12	12	11
Dual tines per arm set	Qty	4	4	5	4	4	4	4
Tine diameter	mm	9.5	9.5	9.5	9.5	9.5	9	9
PROFIX tine arm bracket		●	●	●	●	●	●	–
Windrow-laying position		Center	Center	Center	Center	Center	Center	Center
Four-wheel rotor chassis		● ²	●	–	● ²	● ²	●	●
Six-wheel rotor chassis		○ ³	–	● ²	○	○	○	–
Fully floating suspension		●	●	●	●	●	●	●

Drive systems

PTO shaft speed	rpm	540	540	540	540	540	540	540
Single wide-angle PTO drive shaft		●	●	●	●	●	●	●

Tires

Rotor chassis								
16 x 6.50-8 10 PR		4x4	4x4	2x6	2x4	2x4	2x4	2x4
Main frame								
10.00/75-15.3 10 PR		–	–	–	–	2	2	2
500/55-20		–	○	–	–	–	–	–
620/40 R 22.5		2	○	–	–	–	–	–
380/55-17		–	2	2	2	○	–	–
Weight approx.	lb (kg)	12,895 (5,480)	9,480 (4,600)	6,173 (2,880)	4,960 (2,250)	4,520 (2,050)	4,190 (1,900)	3,530 (1,600)

Comfort

Spare wheel 16x6.50-8 10 PR		○	○	○	○	○	○	○
Wheel weights		–	–	●	○	○	○	–
Single-rotor lifting function (three-way valve)		–	–	○	○	○	○	○
Electrohydraulic individual rotor lift		●	●	○	○	○	–	–
Electrohydraulic rotor height adjustment		○	○	○	○	○	–	–
LED working lights		○	○	–	–	–	–	–
Hydraulic spool valves		–	1xsa	1xsa	1xsa	1xsa	1xsa	1xsa
		1xsa + fR or LS	1xsa + fR or LS	1xda	1xda	1xda	–	–

- For tire variant 500/55-20
- Front lateral suspension
- For rear pair of rotors

- Windrow curtain
- Rear only
- Hydraulic folding windrow curtain

● Standard ○ Optional – Not available

LINER side delivery rakes ⁴		1900	1800 TWIN	1700 TWIN	800 TWIN	700 TWIN	500 T	450 T	370 T	
		Dual-rotor rakes				Single-rotor rakes				
Mounting					Swinging draw-bar/hitch	Swinging draw-bar/hitch	Swinging draw-bar/hitch	Swinging draw-bar/hitch	Swinging draw-bar/hitch	
Mounting category		Cat. II	Cat. II	Cat. II	–	–	–	–	–	
Working width	ft (m)	26'5" (8.05)	24'5" - 27'7" (7.45–8.4)	22' - 25'9" (6.7–7.85)	13'2" - 24'7" (4–7.5)	11'6" - 20'8" (3.5–6.3)	15'9" (4.8)	14'9" (4.5)	11'6" (3.5)	
Transport width	ft (m)									
with tine arms attached	ft (m)	9'10" (2.99)	9'10" (2.99)	9'6"/9'10" (2.89/2.99)	11'10" (3.6)	9'10" (3)	12'6" (3.8) ³	11'6" (3.5) ³	9'6" (2.9)	
with tine arms removed	ft (m)	–	–	–	7'11" (2.42)	7'11" (2.42)	8'3" (2.5)	7'3" (2.2)	9'9" (2.98)	
Transport height										
with tine arms attached	ft (m)	13'1" (3.99)	13'1" (3.99)	13'1" (3.99)	–	–	–	–	–	
with tine arms removed	ft (m)	–	–	–	–	–	8' (2.45)	8' (2.45)	5'3" (1.6)	
Parking length (transport position)	ft (m)	31'8" (9.64)	30'2" (9.19)	28'5" (8.66)	28' (8.55)	26'3" (8)	18'3" (5.55)	17'3" (5.25)	15'7" (4.75)	
Weight approx.	lb (kg)	5,709 (2,590)	5,467 (2,480)	4,895 (2,220)	3,570 (1,620)	3,175 (1,440)	1,730 (785)	1,455 (660)	1,160 (525)	
Rotors	Qty	2	2	2	2	2	1	1	1	
Rotor diameter	ft (m)	12'6" (3.8)	11'6" (3.5)	10'6" (3.2)	11'6" (3.5)	9'6" (2.9)	12'6" (3.8)	11'6" (3.5)	9'6" (2.9)	
Tine arms per rotor set	Qty	14	12	12	12	11	14	12	12	
Dual tines per arm set	Qty	4	4	4	4	4	4	4	4	
Tine diameter	mm	9.5	9.5	9.5	9.5	9.5	9.5	9	9	
PROFIX tine arm bracket		●	●	●	●	●	●	●	●	
Windrow-laying position		left	left	left	left	left	left	left	left	
Four-wheel rotor chassis		●	●	●	●	●	●	●	●	
Six-wheel rotor chassis		○	○	○	–	–	–	–	–	
Tires										
Rotor chassis	16 x 6.50-8 10 PR	2x4 (2x6 ○)	2x4 (2x6 ○)	2x4 (2x6 ○)	–	–	–	–	–	
	18x8.50-8 6 PR	–	–	–	2x4	2x4	4	4	4	
Main frame	10.00/75-15.3 10 PR	–	–	●	–	–	–	–	–	
	380/55-17	●	●	–	–	–	–	–	–	
	340/55-16	–	–	○	–	–	–	–	–	
Fully floating suspension		●	●	●	● ⁵	● ⁵	–	–	–	
Drive systems										
PTO shaft speed	rpm	540	540	540	540	540	540	540	540	
Single wide-angle PTO drive shaft		●	●	●	●	●	●	●	●	
Comfort										
Spare wheel 16x6.50-8 10 PR		○	○	○	–	–	–	–	–	
Spare wheel 18x8.50-8 6 PR		–	–	–	○	○	–	–	–	
Wheel weights		○	○	○	–	–	–	–	–	
Double wide-angle PTO drive shaft		–	–	–	○	○	–	–	–	
TWIN function		–	●	●	●	●	–	–	–	
Guide wheel at front		–	–	–	○	○	○	○	○	
Hydraulic folding of swath guard		○	○	○	○	○	○	○	○	
Hydraulic rotor height adjustment		–	–	–	–	–	–	–	–	
Warning sign		–	–	–	–	–	○	○	○	
Warning sign with illumination		●	●	●	●	●	○	○	○	
Parallelogram drawbar		–	–	–	●	●	○	○	○	
Hydraulic spool valves		1xsa 1xda	1xsa 1xda	1xsa 1xda	1xsa 1xda	1xsa 1xda	1xsa + 1xda ⁶	1xsa + 1xda ⁶	1xsa + 1xda ⁶	

CLAAS continually develops its products to meet customer needs. This means that all products are subject to change without notice. All descriptions and specifications in this brochure should be considered approximate and may include optional equipment that is not part of the standard specifications. This brochure is designed for worldwide use. Please refer to your nearest CLAAS dealer and their price list for local specification details. Some protective panels may have been removed for photographic purposes in order to present the function clearly. To avoid any risk of danger, never remove these protective panels yourself. In this respect, please refer to the relevant instructions in the operator's manual.

All technical specifications relating to engines are based on the European emission regulation standards: Stage. Any reference to the Tier standards in this document is intended solely for information purposes and ease of understanding. It does not imply approval for regions in which emissions are regulated by Tier.



Ensuring a better **harvest.**

CLAAS of America Inc.
8401 S 132nd Street
Omaha, NE 68138
Phone +1 (402) 861-1000
Fax +1 (402) 861-1003
www.claas.com