



MERIDIAN

OPERATOR'S MANUAL



FOR OWNERS OF MERIDIAN BUILT
SMOOTHWALL HOPPER BINS

www.meridianmfg.com

MERIDIAN MANUFACTURING INC.

Extended Materials and Workmanship Warranty

Meridian Manufacturing Inc. (hereinafter referred to as the Manufacturer) hereby warrants the bin(s) sold by it to be free from any defect in material or workmanship under normal use and service for a period of five (5) years from the date of shipment. Manufacturer's Warranty is as follows: ten (10) years on structural integrity, one (1) year paint for liquid and commercial storage bins from the date of shipment to owner and in the manner referred to in paragraph 2 herein.

THIS WARRANTY IS SUBJECT TO THE FOLLOWING LIMITATIONS, PROVISIONS AND CONDITIONS:

1. This warranty does not apply:
 - a) to any product sold by the Manufacturer where it is used in areas exposed to corrosive or aggressive conditions including salt water, acids, alkaloid, ash, cement dust, animal waste or other corrosive chemicals from either inside or outside the bin.
 - b) for failures or defects arising out of damage during shipment or during storage on site.
 - c) to materials replaced or repaired under this warranty except to the extent of the remainder of the applicable warranty.
 - d) to damage resulting from misuse, negligence, accident or improper site preparation by others.
 - e) if the product has been altered or modified by others.
 - f) if in the case of coating failures the failure is the result of damage, lack of proper maintenance or failure to remove road salt or other contaminants that may have come in contact with the bin surface.
 - g) if the product has not been erected and installed strictly in accordance with the Manufacturer's manuals and instructions.
2. The obligation of the Manufacturer under this warranty shall not arise unless the Manufacturer is notified and this warranty is presented together with a written statement specifying the claim or defect within thirty (30) days after the failure is first detected or made known to the owner and within five (5) years for general and coating claims and ten (10) years for structural claims, from the shipment date. The Manufacturer in its sole discretion shall determine if the claim is valid and whether correction of the defect or failure shall be made by repair or replacement of the materials.
3. The obligation of the Manufacturer hereunder extends only to the original owner and to the Meridian dealer to whom the materials may have been initially sold. This warranty shall not be subject to any assignment or transfer without the written consent of the Manufacturer.
4. The customer shall acknowledge that it has made its own independent decision to approve the use of the supplied materials and also the specific fabrication and construction procedures utilized to complete the bin, and has satisfied itself as to the suitability of these products for this particular application.
5. The foregoing sets forth the only warranties applicable to said materials and said warranties are given expressly and in lieu of all other warranties, expressed or implied, statutory or otherwise, of merchantability or fitness for a particular purpose and all warranties which exceed or differ from said warranties herein are disclaimed by the Manufacturer.
6. The owner's sole and exclusive remedy against the Manufacturer shall be limited to the applicable warranty set forth herein and the endorsements, if any, issued together with this document and no other remedy (including but not limited to the recovery of assembly or disassembly costs, shipping costs, direct, incidental, special, indirect or consequential damages for lost profits, lost sales, injury to person or property or any other loss, whether arising from breach of contract, breach of warranty, tort, including negligence, strict liability or otherwise) shall be available to the owner or Meridian Dealer or any other person or entitles whether by direct action or for contribution or indemnity or otherwise.
7. The financial obligation of the Manufacturer under this warranty shall be limited to the repair or replacement of the product as originally supplied and in no event shall exceed the original cost of the product supplied.
8. The Manufacturer shall not have any obligation under any warranty herein until all accounts for materials, installation and erection of the said product thereof and for labor and other work performed by the Manufacturer or its dealers have been paid in full by the owner.

Warranty Claim Procedure

- Should you find any factory defects, please advise your dealer immediately.
- Dealer will supply you as the customer with a warranty claim sheet and or direct you to our customer service rep.
- Warranty claim must be completed with **ALL** the information required in order for the claim to be accepted.
- Once the warranty claim has been received by our company, someone will be in contact with you the customer.
- All warranty claims will be dealt with at the discretion of a Meridian Manufacturing Inc. Representative.

TABLE OF CONTENTS

SECTION	DESCRIPTION	PAGE
1	Introduction	1
2	Safety	2
2.1	General Safety	3
2.2	Equipment Safety Guidelines	4
2.3	Safety Training	5
2.4	Safety Signs.....	5
2.5	Preparation	6
2.6	Operating Safety.....	7
2.7	Maintenance Safety.....	8
2.8	Lock-Out Tag-Out Safety	8
2.9	Sign-Off Form	9
3	Safety Sign Locations	10
4	Set-Up and Installation	12
4.1	Bin Location.....	12
4.1.1	Bin Foundation.....	13
4.1.2	Pad Construction	14
4.2	Design Loads and Concrete Pad Sizes.....	14
4.2.1	Concrete Pad Specifications – Square	15
4.2.2	Concrete Pad Specifications – Round	16
4.3	Installation	17
5	Operation.....	18
5.1	To the New Operator or Owner.....	18
5.2	Controls	19
5.3	Loading.....	20
5.4	Unloading	20
5.5	Optional Features/Equipment.....	21
5.5.1	Aeration System.....	21
5.5.2	Ladders	22
5.5.3	Manholes.....	23
5.5.4	Access Manway	23
5.5.5	Bean Ladder.....	23
5.5.6	Auger Mounting Boot.....	24
5.5.7	Pail Chute.....	24
5.5.8	Poke Hole.....	24
5.5.9	Leg Extensions.....	24
5.5.10	Hopper Bottom Cones	25
5.5.11	View Glasses	25
5.5.12	Paint (Internal)	26
5.5.13	Other Options.....	26
6	Maintenance.....	27
7	Specifications	28
8	Index	29
9	Warranty Registration Form	30

1 INTRODUCTION

Congratulations on your choice of a Meridian Manufacturing Inc. Hopper Bottom Bin to complement your feed, seed, grain and fertilizer storage system for your farming operation. This equipment has been designed and manufactured to meet the exacting standards for such equipment in the agricultural industry and will keep your feeding, seeding and fertilizing operation working at optimum efficiency.

Safe, efficient and trouble free operation of your Hopper Bottom Bin requires that you and anyone else who will be operating or maintaining the Bin, read and understand the Safety, Operation, Maintenance and Trouble Shooting information contained within the Operator's Manual.



This manual covers the Hopper Bottom Bins made by Meridian Manufacturing Inc. Differences are explained where appropriate. Use the Table of Contents and Index as a guide to locate required information.

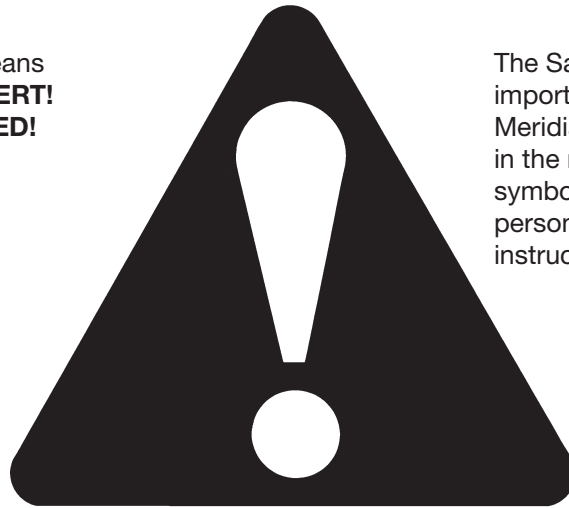
Keep this manual handy for frequent reference and to pass on to new operators or owners. Call your Meridian Manufacturing Inc. dealer or distributor if you need assistance, information or additional copies of the manuals.

OPERATOR ORIENTATION – The directions left, right, front and rear, as mentioned throughout this manual, are as seen from the slide gate crank and facing in the direction of the center of the Bin.

2 SAFETY

SAFETY ALERT SYMBOL

This Safety Alert symbol means **ATTENTION! BECOME ALERT! YOUR SAFETY IS INVOLVED!**



The Safety Alert symbol identifies important safety messages on the Meridian Hopper Bottom Bin and in the manual. When you see this symbol, be alert to the possibility of personal injury or death. Follow the instructions in the safety message.

Why is SAFETY important to you?

3 Big Reasons

Accidents Disable and Kill
Accidents Cost
Accidents Can Be Avoided

SIGNAL WORDS:

Note the use of the signal words **DANGER**, **WARNING** and **CAUTION** with the safety messages. The appropriate signal word for each message has been selected using the following guide-lines:

DANGER - Indicates an imminently hazardous situation that, if not avoided, will result in death or serious injury. This signal word is to be limited to the most extreme situations typically for machine components which, for functional purposes, cannot be guarded.

WARNING - Indicates a potentially hazardous situation that, if not avoided, could result in death or serious injury, and includes hazards that are exposed when guards are removed. It may also be used to alert against unsafe practices.

CAUTION - Indicates a potentially hazardous situation that, if not avoided, may result in minor or moderate injury. It may also be used to alert against unsafe practices.

If you have any questions not answered in this manual or require additional copies or the manual is damaged, please contact your dealer or Meridian Manufacturing Inc., P.O. Box 760, 275 Hespler Ave., Winkler, MB, R6W 4A8. (Telephone) 204-325-7883, (FAX) 204-325-5556.

SAFETY

YOU are responsible for the **SAFE** operation and maintenance of your Meridian Hopper Bottom Bin. **YOU** must ensure that you and anyone else who is going to operate, maintain or work around the Hopper Bottom Bin be familiar with the operating and maintenance procedures and related **SAFETY** information contained in this manual. This manual will take you step-by-step through your working day and alerts you to all good safety practices that should be adhered to while operating the Bin.

Remember, **YOU** are the key to safety. Good safety practices not only protect you but also the people around you. Make these practices a working part of your safety program. Be certain that **EVERYONE** operating this equipment is familiar with the recommended operating and maintenance procedures and follows all the safety precautions. Most accidents can be prevented. Do not risk injury or death by ignoring good safety practices.

- Bin owners must give operating instructions to operators or employees before allowing them to operate the machine, and at least annually thereafter per OSHA (Occupational Safety and Health Administration) regulation 1928.57.
- The most important safety feature on this equipment is a **SAFE** operator. It is the operator's responsibility to read and understand **ALL** Safety and Operating instructions in the manual and to follow these. Most accidents can be avoided.
- A person who has not read and understood all operating and safety instructions is not qualified to operate the machine. An untrained operator exposes himself/herself and bystanders to possible serious injury or death. Always be and stay alert to any possible unsafe operating or maintenance procedures or conditions.
- Do not modify the equipment in any way. Unauthorized modification may impair the function and/or safety of the components and systems and could affect the life of the equipment, possibly invalidating the warranty coverage.
- Think SAFETY! Work SAFELY!

2.1 GENERAL SAFETY

1. Read and understand the Operator's Manual and all safety signs before operating, maintaining, adjusting or unplugging the Bin.



2. Have a first-aid kit available

for use should the need arise and know how to use it.



3. Have a fire extinguisher available for use should the need arise and know how to use it.



4. Wear appropriate protective gear. This list includes but is not limited to:

- A hard hat
- Protective shoes with slip resistant soles
- Protective goggles, glasses or face shield
- Heavy gloves
- Protective clothing
- Respirator



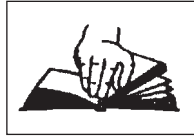
5. Install and secure all guards before starting.
6. Establish a lock-out tag-out policy for the work site. Be sure all personnel are trained in and follow all procedures. Lock-out tag-out all power sources before entering bin or working around loading/unloading equipment.
7. Clear the area of people, especially small children, before starting.
8. Review safety related items annually with all personnel who will be using or maintaining the bin.

2.2 EQUIPMENT SAFETY GUIDELINES

1. Safety of the operator and bystanders is one of the main concerns in designing and developing a machine. However, every year many accidents occur which could have been avoided by a few seconds of thought and a more careful approach to handling equipment. You, the operator, can avoid many accidents by observing the following precautions in this section. To avoid personal injury or death, study the following precautions and insist those working with you, or for you, follow them.
2. In order to provide a better view, certain photographs or illustrations in this manual may show an assembly with a safety shield removed. However, equipment should never be operated in this condition. Keep all shields in place. If shield removal becomes necessary for repairs, replace the shield prior to use.
3. Replace any safety sign or instruction sign that is not readable or is missing. Location of such safety signs is indicated in this manual.
4. Never use alcoholic beverages or drugs which can hinder alertness or coordination while operating this equipment. Consult your doctor about operating this machine while taking prescription medications.
5. **Under no circumstances should young children be allowed to work with this equipment. Do not allow persons to operate or assemble this unit until they have read this manual and have developed a thorough understanding of the safety precautions and of how it works.** Review the safety instructions with all users annually.
6. This equipment is dangerous to children and persons unfamiliar with its operation. The operator should be a responsible, properly trained and physically able person familiar with farm machinery and trained in this equipment's operations. If the elderly are assisting with farm work, their physical limitations need to be recognized and accommodated.
7. Never exceed the limits of a piece of machinery. If its ability to do a job, or to do so safely, is in question – **DON'T TRY IT.**
8. Do not modify the equipment in any way. Unauthorized modifications result in serious injury or death and may impair the function and life of the equipment.
9. In addition to the design and configuration of this implement, including Safety Signs and Safety Equipment, hazard control and accident prevention are dependent upon the awareness, concern, prudence, and proper training of personnel involved in the operation, transport, maintenance, and storage of the machine. Refer also to Safety Messages and operation instruction in each of the appropriate sections of the auxiliary equipment and machine Manuals. Pay close attention to the Safety Signs affixed to the auxiliary equipment and the machine.

2.3 SAFETY TRAINING

1. Safety is a primary concern in the design and manufacture of our products. Unfortunately, our efforts to provide safe equipment can be wiped out by a single careless act of an operator or bystander.
2. In addition to the design and configuration of equipment, hazard control and accident prevention are dependent upon the awareness, concern, prudence and proper training of personnel involved in the operation, transport, maintenance and storage of this equipment.
3. It has been said, "The best safety feature is an informed, careful operator." We ask you to be that kind of an operator. It is the operator's responsibility to read and understand ALL Safety and Operating instructions in the manual and to follow these. Accidents can be avoided.
4. Working with unfamiliar equipment can lead to careless injuries. Read this manual, and the manual for your auxiliary equipment, before assembly or operating, to acquaint yourself with the machines. If this machine is used by any person other than yourself, it is the machine owner's responsibility to make certain that the operator, prior to operating:
 - a. Reads and understands the operator's manuals.
 - b. Is instructed in safe and proper use.
5. Know your controls and how to stop augers, conveyors and any other auxiliary equipment quickly in an emergency. Read this manual and the one provided with your other equipment.
6. Train all new personnel and review instructions frequently with existing workers. Be certain only a properly trained and physically able person will operate the machinery. A person who has not read and understood all operating and safety instructions is not qualified to operate the machine. An untrained operator exposes himself and bystanders to possible serious injury or death. If the elderly are assisting with farm work, their physical limitations need to be recognized and accommodated.



2.4 SAFETY SIGNS

1. Keep safety signs clean and legible at all times.
2. Replace safety signs that are missing or have become illegible.
3. Replaced parts that displayed a safety sign should also display the current sign.
4. Safety signs are available from your authorized Distributor or Dealer Parts Department or the factory.

How to Install Safety Signs:

- Be sure that the installation area is clean and dry.
- Be sure temperature is above 50°F (10°C).
- Determine exact position before you remove the backing paper. (See Section 3).
- Remove the smallest portion of the split backing paper.
- Align the sign over the specified area and carefully press the small portion with the exposed sticky backing in place.
- Slowly peel back the remaining paper and carefully smooth the remaining portion of the sign in place.
- Small air pockets can be pierced with a pin and smoothed out using the piece of sign backing paper.

2.5 PREPARATION

1. Never operate the Bin and auxiliary equipment until you have read and completely understand this manual, the auxiliary equipment Operator's Manual, and each of the Safety Messages found on the safety signs on the Bin and auxiliary equipment.

2. Personal protection equipment including hard hat, safety glasses, safety shoes, and gloves are



required during assembly, installation, operation, adjustment, maintaining, repairing, removal, or moving the implement. Do not allow long hair, loose fitting clothing or jewellery to be around equipment.

3. **PROLONGED EXPOSURE TO LOUD NOISE MAY CAUSE PERMANENT HEARING LOSS!**

Motors or equipment attached can often be noisy enough to cause permanent, partial hearing loss. We recommend that you wear hearing protection on a full-time basis if the noise in the Operator's position exceeds 80db. Noise over 85db on a long-term basis can cause severe hearing loss. Noise over 90db adjacent to the Operator over a long-term basis may cause permanent, total hearing loss.



NOTE: Hearing loss from loud noise (from tractors, chain saws, radios, and other such sources close to the ear) is cumulative over a lifetime without hope of natural recovery.

4. Clear working area of debris, trash or hidden obstacles that might be hooked or snagged, causing injury, damage or tripping.
5. Operate only in daylight or good artificial light.
6. Be sure machine is properly anchored, adjusted and in good operating condition.
7. Ensure that all safety shielding and safety signs are properly installed and in good condition.
8. Before starting, give the machine a "once over" for any loose bolts, worn parts, cracks, leaks, frayed belts and make necessary repairs. Always follow maintenance instructions.

2.6 OPERATING SAFETY

1. Make sure that anyone who will be operating the bin or working on or around the unit reads and understands all the operating, maintenance and safety information in the operator's manual.
2. Keep all bystanders, especially children, away from the bin when loading or unloading is being done, or when authorized personnel are carrying out maintenance work.
3. Do not crawl under the opened unloading chute to inspect for a suspected blockage. This is an unsafe practice. Caked or impacted product could suddenly break loose and cause facial and/or eye injury.
4. Do not attempt to enter the hopper bin through the top loading hatch. This opening is designed for loading the bin only and not for human entry.
5. Use the inspection manway only for entry into the bin and only when the bin is empty for cleaning purposes.
6. If you enter the bin, make sure that there is no possibility that either the loading or unloading auger could be started up. Lock out the power sources for the augers and have a responsible, trained person close at hand to keep unauthorized individuals away from the work area.
7. Establish a lock-out tag-out policy for the work site. Be sure all personnel are trained in and follow all procedures. Lock-out tag-out all power sources before entering bin or working around loading/unloading equipment.
8. Enter the empty bin with extreme caution and wear protective clothing, goggles for eye protection and a properly filtered respirator mask for lung protection. It is also good safety practice to connect a safety line to yourself and a secure attachment point outside the bin before entering the enclosed area.
9. Do not enter the bin from the top loading hatch or the inspection manway at the bottom of the bin to break loose impacted, caked or bridged material. You could fall through the bridged material if you are trying to clear it from the top. Or have it cave in on you from the bottom. Either situation could result in you being buried in the falling material and suffocating.
10. If material is bridged or caked causing a blockage. Use a long pole, a length of board or a stick to break the material loose.
11. Be very careful when you are climbing up or down the loading hatch access ladder. Remove excess mud or other material from your footwear that could cause slipping.
12. Make sure the safety section of the access ladder is raised and latched in place to prevent children and other unauthorized persons from climbing up on the bin.
13. The optional inspection manway should not be used inserting an auger to load or unload material. This will cause the material to be off center, either piling up or emptying unevenly to one side of the bin. This uneven stressing of the bin could cause structural damage.
14. Review safety related items annually with all personnel who will be operating, using or maintaining the Bin.

2.7 MAINTENANCE SAFETY

1. Good maintenance is your responsibility.
Poor maintenance is an invitation to trouble.

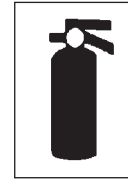
2. Follow good shop practices.

- Keep service area clean and dry.
- Be sure electrical outlets and tools are properly grounded.
- Use adequate light for the job at hand.



3. Do not crawl under the opened unloading chute to inspect for a suspected blockage. This is an unsafe practice. Caked or impacted product could suddenly break loose and cause facial and/or eye injury.
4. If you enter the bin, make sure that there is no possibility that either the loading or unloading auger could be started up. Lock out the power sources for the augers and have a responsible, trained person close at hand to keep unauthorized individuals away from the work area.
5. Review safety related items annually with all personnel who will be operating, using or maintaining the Bin.
6. Enter the empty bin with extreme caution and wear protective clothing, goggles for eye protection and a properly filtered respirator mask for lung protection. It is also good safety practice to connect a safety line to yourself and a secure attachment point outside the bin before entering the enclosed area.
7. Use personal protection devices such as eye, hand, breathing and hearing protectors, when performing any service or maintenance work.
8. A fire extinguisher and first aid kit should

be kept readily accessible while performing maintenance on this equipment.



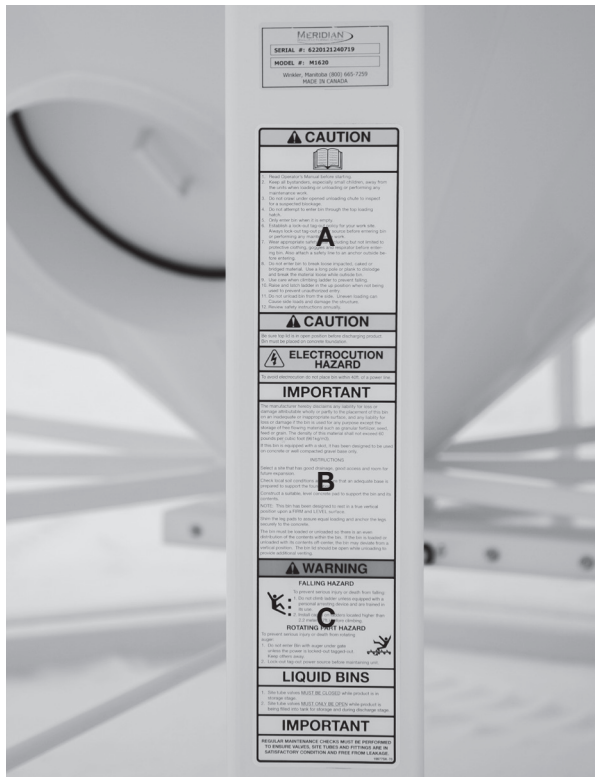
9. Periodically tighten all bolts, nuts and screws and check that all cotter pins are properly installed to ensure unit is in a safe condition.
10. When completing a maintenance or service function, make sure all safety shields and devices are installed before placing unit in service.

2.8 LOCK-OUT TAG-OUT SAFETY

1. Establish a formal Lock-Out Tag-Out program for your operation.
2. Train all operators and service personnel before allowing them to work around the Bin.
3. Provide tags at the work site and a sign-up sheet to record tag out details.

3 SAFETY SIGN LOCATIONS

The types of safety signs and locations on the equipment are shown in the illustration below. Good safety requires that you familiarize yourself with the various safety signs, the type of warning and the area, or particular function related to that area, that requires your SAFETY AWARENESS.



A

CAUTION



1. Read Operator's Manual before starting.
2. Keep all bystanders, especially small children, away from the units when loading or unloading or performing any maintenance work.
3. Do not crawl under opened unloading chute to inspect for a suspected blockage.
4. Do not attempt to enter bin through the top loading hatch.
5. Only enter bin when it is empty.
6. Establish a lock-out tag-out policy for your work site. Always lock-out tag-out power source before entering bin or performing any maintenance work.
7. Wear appropriate safety gear including but not limited to protective clothing, goggles and respirator before entering bin. Also attach a safety line to an anchor outside before entering.
8. Do not enter bin to break loose impacted, caked or bridged material. Use a long pole or plank to dislodge and break the material loose while outside bin.
9. Use care when climbing ladder to prevent falling.
10. Raise and latch ladder in the up position when not being used to prevent unauthorized entry.
11. Do not unload bin from the side. Uneven loading can cause side loads and damage the structure.
12. Review safety instructions annually.

CAUTION

Be sure top lid is in open position before discharging product. Bin must be placed on concrete foundation.

ELECTROCUTION HAZARD

To avoid electrocution do not place bin within 40ft. of a power line.

B

IMPORTANT

The manufacturer hereby disclaims any liability for loss or damage attributable wholly or partly to the placement of this bin on an inadequate or inappropriate surface, and any liability for loss or damage if the bin is used for any purpose except the storage of free flowing material such as granular fertilizer, seed, feed or grain. The density of this material shall not exceed 60 pounds per cubic foot (961kg/m3).

If this bin is equipped with a skid, it has been designed to be used on concrete or well compacted gravel base only.

INSTRUCTIONS

Select a site that has good drainage, good access and room for future expansion.

Check local soil conditions and ensure that an adequate base is prepared to support the foundation.

Construct a suitable, level concrete pad to support the bin and its contents.


NOTE: This bin has been designed to rest in a true vertical position upon a **FIRM** and **LEVEL** surface.

Shim the leg pads to assure equal loading and anchor the legs securely to the concrete.

The bin must be loaded or unloaded so there is an even distribution of the contents within the bin. If the bin is loaded or unloaded with its contents off-center, the bin may deviate from a vertical position. The bin lid should be open while unloading to provide additional venting.

REMEMBER – If safety signs have been damaged, removed, become illegible or parts replaced without signs, new signs must be applied. New signs are available from your authorized dealer.


C

 **WARNING**

FALLING HAZARD

To prevent serious injury or death from falling:


- 1. Do not climb ladder unless equipped with a personal arresting device and are trained in its use.
- 2. Install cages on ladders located higher than 2.2 meters (7ft.) before climbing.



ROTATING PART HAZARD

To prevent serious injury or death from rotating auger:

- 1. Do not enter Bin with auger under gate unless the power is locked-out tagged-out. Keep others away.
- 2. Lock-out tag-out power source before maintaining unit.



LIQUID BINS

- 1. Site tube valves MUST BE CLOSED while product is in storage stage.
- 2. Site tube valves MUST ONLY BE OPEN while product is being filled into tank for storage and during discharge stage.

IMPORTANT

REGULAR MAINTENANCE CHECKS MUST BE PERFORMED TO ENSURE VALVES, SITE TUBES AND FITTINGS ARE IN SATISFACTORY CONDITION AND FREE FROM LEAKAGE.

HD1119977SK-70

REMEMBER – If safety signs have been damaged, removed, become illegible or parts replaced without signs, new signs must be applied. New signs are available from your authorized dealer.

4 SET-UP AND INSTALLATION



INSTALLATION SAFETY

1. Read instruction manuals before starting.
2. Clear the area of bystanders, especially small children.
3. Prepare the base carefully to be sure the bin is supported evenly to prevent tipping.
4. Use extra care when moving bin. Never move a bin that has material in it.
5. Use only an approved hoist, crane or other lifting system when positioning bin.
6. Secure, anchor or stack base when positioned.

4.1 BIN LOCATION

It is important that the customer plan the storage and work site to minimize or eliminate the need to move the bin(s) once they are positioned. Extra care must be used when moving and/or positioning a bin.

Some general guidelines include but are not limited to:

1. Clear the area of bystanders, especially small children.
2. Use only hoists, jack and/or cranes with sufficient lift capacity and reach for the bin being positioned.
3. Have at least one other trained and responsible person to assist and who can, in the case of an emergency or accident, provide assistance or seek assistance.
4. Do not move or transport bins when it is windy. They are a large, clumsy, hard to hold object that the wind can catch and move without warning. Wait for a calmer day.
5. Be sure the bin is positioned on a base that has been properly prepared to support the weight and loads of the bin when it is being used.
6. Stay away from power lines when lifting or moving the bin during installation. Electrocutation can occur without direct contact.

4.1.1 BIN FOUNDATION

Although the bin base can be temporary, it is recommended that a permanent concrete base be constructed so it can support and carry the weight and load of the bin full of stored material.

1. Temporary Skid Base:

If a temporary skid is attached, the unit must be placed on a minimum of 10 inches of compacted granular fill so that the entire bearing area of the skid rests evenly on the area. The fill should be in an area with proper type of soil and good drainage to provide a firm base.

IMPORTANT

This should be only a temporary base. It is highly recommended that a good concrete pad be used as a permanent base.

2. Concrete Pad (Permanent Base):

The best, and recommended, type of base is a concrete pad that is located on well drained, level ground that is capable of supporting the concrete pad and hopper bin under all environmental conditions. It is recommended to have the soil conditions checked by a professional engineer to ensure that the area has adequate bearing capacity. If a custom pad is being designed, Meridian can provide your engineer with required leg reactions (wind and weight load).

The bin must be bolted to the pad so that all the legs will sit evenly and be firmly in contact with the concrete. If the concrete is uneven, full "leg base plate" shims can be used.



Fig. 1 CONCRETE PAD (TYPICAL)

4.1.2 PAD CONSTRUCTION

The following information provides specifications and general guidelines for construction of concrete slabs for supporting hopper bins.

It is very important that close attention be given to site preparation and soil conditions in order to provide a good base for the concrete pad.

Items to be aware of include but are not limited to:

1. Soil Conditions:

Sod and other organic material must be removed before laying down the gravel till. Positive drainage must be provided to drain excessive moisture away from the concrete pad.

The concrete pad is designed for load stresses on soils with minimum allowable soil bearing capacity of 1500 psf. The designer is not responsible for concrete pad performance on soils with lower than specified bearing capacity or soils that are unsuitable for supporting a concrete pad.

Soil conditions should be assessed on the basis of soil tests or on the performance history of similar structures in your local area.

2. Slab Structures:

The following specifications must be followed to construct a concrete pad to meet the load and stress carrying requirements:

- a. The concrete must have a minimum 28 day strength of 3000 psi (1361 kg).
- b. Use sulphate resistant cement where required by soil conditions.
- c. Do not pour concrete on frozen ground or in an excavation that contains ice, snow, excessive moisture or when the air temperature is below 4 degrees Celsius (40 deg F).

4.2 DESIGN LOADS AND CONCRETE PAD SIZES

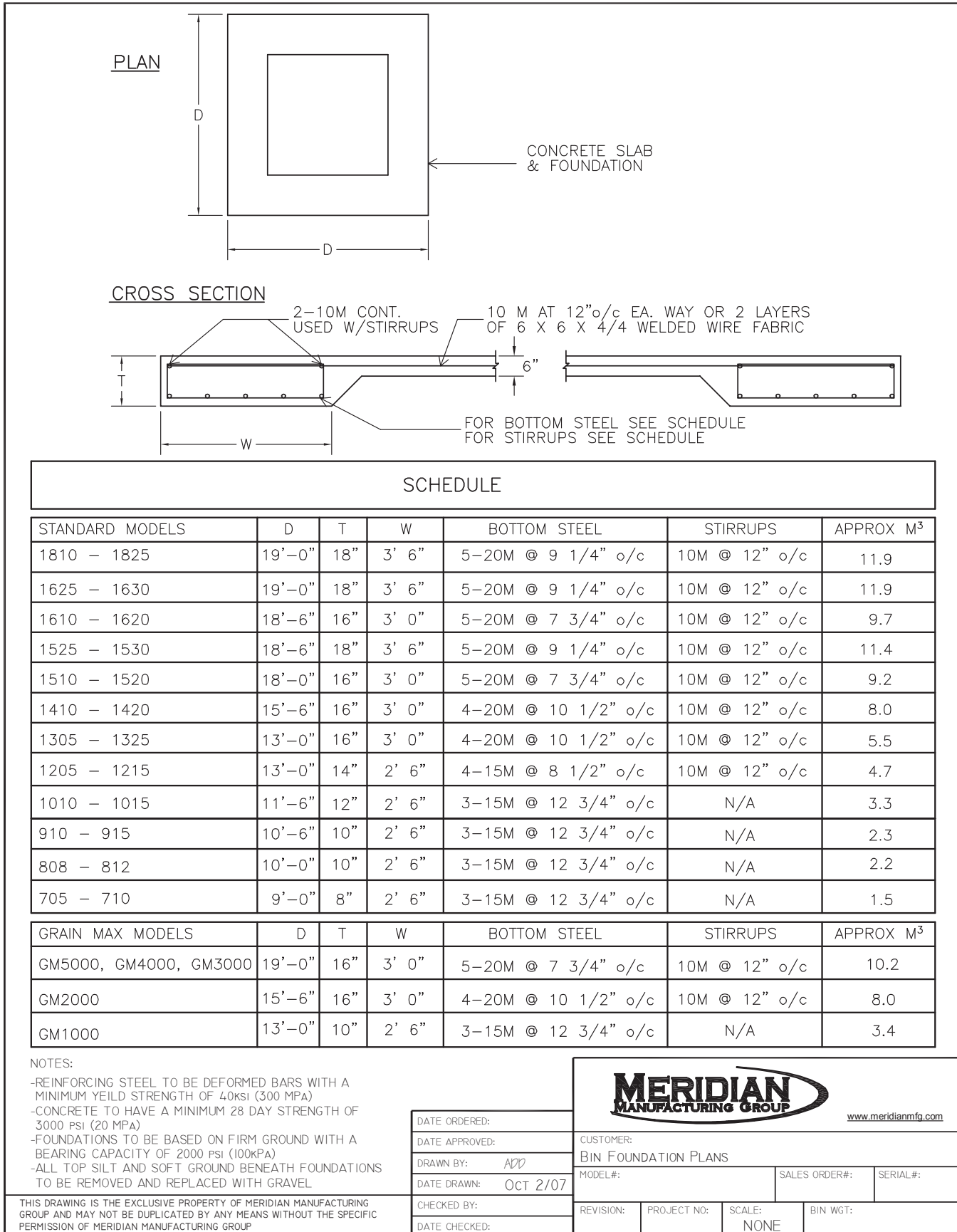
The concrete pad design is based on varied load bearing specifications for the different sized storage bins. The manufacturer is not responsible for damage caused by an inferior concrete pad. It is the responsibility of the owner to ensure that good construction practices are followed to obtain the required load carrying capacity for the pad. A concrete pad built to the proper performance specifications will ensure a long, trouble-free life for the storage system.

We recommend that you consult a civil engineer regarding the site you choose, the soil load bearing capacity and the proper method of construction and type of concrete pad for your needs.

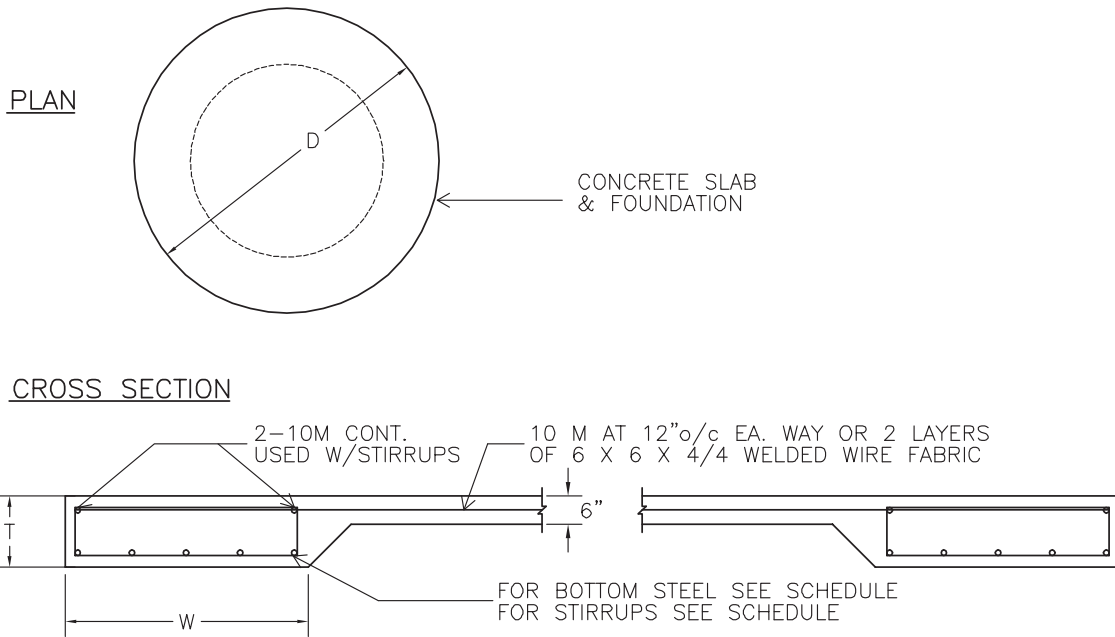


Fig. 2 FEED BIN (TYPICAL)

4.2.1 Concrete Pad Specifications – Square



4.2.2 Concrete Pad Specifications – Round



SCHEDULE						
STANDARD MODELS	D	T	W	BOTTOM STEEL	STIRRUPS	APPROX M ³
1810 – 1825	19'-0"	18"	3' 6"	5-20M @ 9 1/4" o/c	10M @ 12" o/c	9.3
1625 – 1630	19'-0"	18"	3' 6"	5-20M @ 9 1/4" o/c	10M @ 12" o/c	9.3
1610 – 1620	18'-6"	16"	3' 0"	5-20M @ 7 3/4" o/c	10M @ 12" o/c	7.6
1525 – 1530	18'-6"	18"	3' 6"	5-20M @ 9 1/4" o/c	10M @ 12" o/c	9.0
1510 – 1520	18'-0"	16"	3' 0"	5-20M @ 7 3/4" o/c	10M @ 12" o/c	7.3
1410 – 1420	16'-6"	16"	3' 0"	4-20M @ 10 1/2" o/c	10M @ 12" o/c	6.3
1305 – 1325	14'-0"	16"	3' 0"	4-20M @ 10 1/2" o/c	10M @ 12" o/c	4.9
1205 – 1215	14'-0"	14"	2' 6"	4-15M @ 8 1/2" o/c	10M @ 12" o/c	4.1
1010 – 1015	12'-6"	12"	2' 6"	3-15M @ 12 3/4" o/c	N/A	2.9
910 – 915	11'-6"	10"	2' 6"	3-15M @ 12 3/4" o/c	N/A	2.2
808 – 812	10'-6"	10"	2' 6"	3-15M @ 12 3/4" o/c	N/A	1.8
705 – 710	9'-6"	8"	2' 6"	3-15M @ 12 3/4" o/c	N/A	1.3
GRAIN MAX MODELS	D	T	W	BOTTOM STEEL	STIRRUPS	APPROX M ³
GM5000, GM4000, GM3000	19'-0"	16"	3' 0"	5-20M @ 7 3/4" o/c	10M @ 12" o/c	8.0
GM2000	16'-6"	16"	3' 0"	4-20M @ 10 1/2" o/c	10M @ 12" o/c	6.3
GM1000	14'-0"	10"	2' 6"	3-15M @ 12 3/4" o/c	N/A	3.2

NOTES:

- REINFORCING STEEL TO BE DEFORMED BARS WITH A MINIMUM YIELD STRENGTH OF 40ksi (300 MPa)
- CONCRETE TO HAVE A MINIMUM 28 DAY STRENGTH OF 3000 PSI (20 MPa)
- FOUNDATIONS TO BE BASED ON FIRM GROUND WITH A BEARING CAPACITY OF 2000 PSI (100kPa)
- ALL TOP SILT AND SOFT GROUND BENEATH FOUNDATIONS TO BE REMOVED AND REPLACED WITH GRAVEL

THIS DRAWING IS THE EXCLUSIVE PROPERTY OF MERIDIAN MANUFACTURING GROUP AND MAY NOT BE DUPLICATED BY ANY MEANS WITHOUT THE SPECIFIC PERMISSION OF MERIDIAN MANUFACTURING GROUP

DATE ORDERED:	
DATE APPROVED:	
DRAWN BY:	ADD
DATE DRAWN:	OCT 2/07
CHECKED BY:	
DATE CHECKED:	

MERIDIAN MANUFACTURING GROUP				www.meridianmfg.com	
CUSTOMER: BIN FOUNDATION PLANS					
MODEL #:			SALES ORDER#:	SERIAL #:	
REVISION:	PROJECT NO:	SCALE: NONE	BIN WGT:		

4.3 INSTALLATION

Care must be used when moving, lifting and installing the bin. Installation instructions include but are not limited to:

1. Clear the area of bystanders, especially small children.
2. Never move a bin that has material in it. The legs, base and supporting structure are not designed with sufficient strength to carry the combined mass. Any structural damage occurring during the move, can lead to more problems or damage when the bin is filled at its final position.
3. Do not use the tow hooks on a temporary skid base to pull the bin with any material inside. Because of the inherent high center of gravity and the pulling force that would be concentrated at the tow hooks, the bin would tip over, creating a



Fig. 3 INSTALLING (TYPICAL)

4. safety hazard.
4. If the unit must be pulled, make sure that it is completely empty and that the area that it will be pulled over is firm, level and contains no obstructions. Proceed with extra caution. The bin is top heavy, having a high center of gravity and can tip easily.
5. Have at least one other trained and responsible person to assist and who, in case of an emergency or accident, can provide assistance or seek assistance.
6. Use only a crane, hoist or lift with sufficient load carrying capacity and the appropriate stability to raise, move, position and lower the bin. Do not use handling equipment that does not have the required specifications. Your safety and the integrity of the bin is at stake.
7. It is recommended that installing the bin be done on a calm day or one with light winds. A bin is a large, hard-to-handle object that can easily be caught and moved by the wind. Do not take chances with your safety.
8. Be sure the base cannot move. Stake the skid plate when equipped with a temporary base. Bolt the base to the permanent concrete pad. If the base can move, it can lift or slide and lead to tipping.
9. Stay away from power lines when lifting or moving the bin during installation. Electrocutation can occur without direct contact.
10. Determine the position of the bin loading auger or conveyor. The position of the loading auger or conveyor determines the required position of the loading hatch on the top of the bin. Loosen the hatch clamping bolts and turn the hatch to its required position prior to raising the bin into its permanent position. Tighten clamping bolts to their specified torque and tie the rope to the hatch handle. It is easier to position the hatch before raising the bin than after.

5 OPERATION



OPERATING SAFETY

1. Read Operator's Manual before starting.
2. Keep all bystanders, especially small children, away from the units when loading or unloading or performing any maintenance work.
3. Do not crawl under opened unloading chute to inspect for a suspected blockage.
4. Do not attempt to enter bin through the top loading hatch.
5. Only enter bin when it is empty.
6. Establish a lock-out tag-out policy for your work site. Always lock-out tag-out power source before entering bin or performing any maintenance work.
7. Wear appropriate safety gear including but not limited to protective clothing, goggles and respirator before entering bin. Also attach a safety line to an anchor outside before entering.
8. Do not enter bin to break loose impacted, caked or bridged material. Use a long pole or plank to dislodge and break the material loose while outside bin.
9. Use care when climbing ladder to prevent falling.
10. Raise and latch ladder in the up position when not being used to prevent unauthorized entry.
11. Do not unload bin from the side. Uneven loading can cause side loads and damage the structure.
12. Review safety instructions annually.

5.1 TO THE NEW OPERATOR OR OWNER

The Meridian built Hopper Bin is designed to be used with any feeding storage, seed or fertilizer handling operations. The units have been designed and engineered for loading capacities up to 62 lb. per cubic foot. The Grain Max model up to 50 lb. per cubic foot recommended for grain storage only. It is the responsibility of the operator or user to be familiar with the bin(s) and all auxiliary loading and unloading equipment before starting.

In addition to the design and configuration of equipment, hazard control and accident prevention are dependent upon the awareness, concern, prudence and proper training of personnel involved in the operation, transport, maintenance and storage of equipment. It is the responsibility of the owner or operator to read this manual and to train all other operators before they start working with the equipment. Follow all safety instructions exactly.

Safety is everyone's business. By following recommended procedures, a safe working environment is provided for the operator, bystanders and the area around the work site. Untrained operators are not qualified to operate the equipment.

Many features incorporated into these storage unit(s) are the result of suggestions made by customers like you. Read this manual carefully to learn how to use the bin safely and efficiently. By following the operating instructions in conjunction with a good maintenance program, your Hopper Bin will provide many years of safe and efficient product storage and handling.

5.2 CONTROLS

Always review this section of the manual to be familiar with the controls before working with the bin(s) or system. Be sure to follow the lock-out tag-out procedure for your work site.

1. Unloading Door:

This crank controls the position of the discharge door at the base of the bin. Turn the crank clockwise to close the discharge door and counterclockwise to open it.

2. Electrical Controls:

A variety of control systems and switches can be used with a storage system for loading and unloading. Always have a licensed electrician provide the power and controls for your system.

3. Top Lid:

Each bin is equipped with a spring-loaded top lid on the top. A rope attached to the lid and extending down to the ground allows the operator to open or close the lid as required. Pull on the rope to open the lid and release it to close.

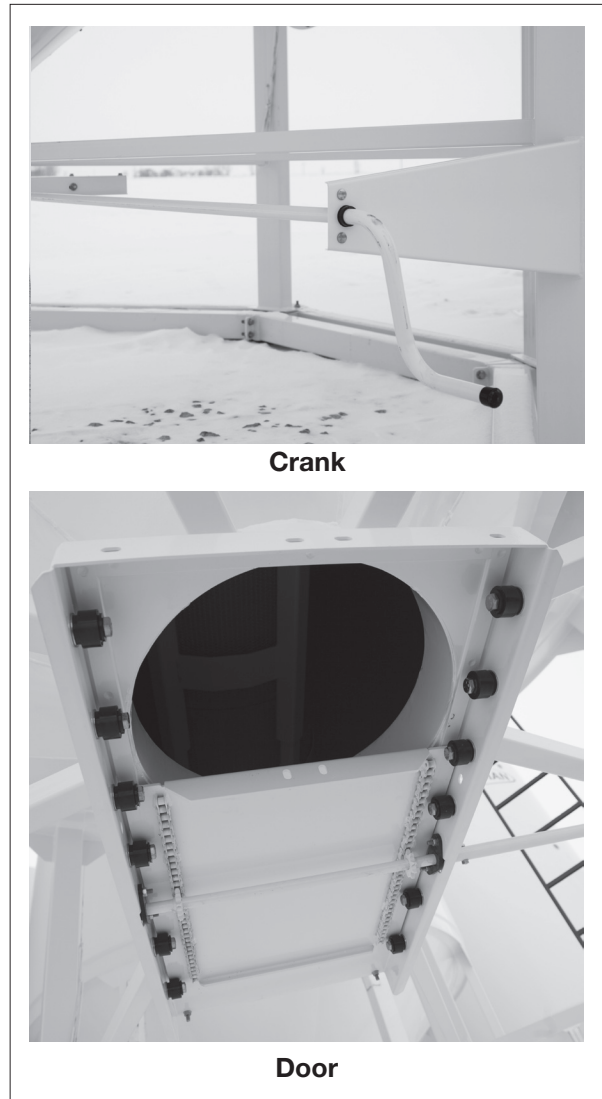


Fig. 4 UNLOADING SYSTEM



Fig. 5 LOADING TOP LID

5.3 LOADING

The bin(s) are designed to be easy to load/unload or fill/empty for storage and/or transport of product. A list of general guidelines to be followed include but are not limited to:

1. A spring-loaded vented lid covers the loading hatch and can be opened from the ground by pulling on the rope provided. The spring loading will automatically close the lid when the cord is released. The venting of the lid allows the bin to "breathe", avoiding vacuum lock when unloading.
2. The lid is designed so that it can be installed to open in any direction that will work favorably with your particular installation. Before erecting the bin, decide on the opening direction and make the adjustment. This will be more convenient than waiting until the bin is set in place.
3. A Hopper Bottom Bin should always be center loaded and unloaded to prevent uneven stresses on the bin caused by material piling up on one side and emptying from the other. Over stressing in this manner will cause eventual structural damage.
4. The loading hatch at the top of the bin is designed so that the material will center load when a specified loading auger is used when filling the bin.
5. The unloading chute at the base of the bin is so designed that the material will center unload.
6. Do not, under any circumstances, attempt to use the optional inspection manhole as either a loading or unloading port. If the manhole is used for these purposes, the material will pile up or empty unevenly, creating a situation that could cause damage to the unit.
7. If a skid is being used as a base, make sure that you have a level, well-packed gravel base pad consisting of a minimum of 10" in an area that provides proper soil type and good drainage. You should consult your local engineer to confirm soil type.

IMPORTANT

This should be only a temporary base. It is highly recommended that a good concrete pad be used as a permanent base.

5.4 UNLOADING

The standard Hopper Bin is designed with 2 feet of clearance at the bottom of the cone to provide room for unloading equipment or a system. Use the auxiliary unloading equipment as appropriate for your storage system. A list of general guidelines to be followed include but are not limited to:

1. To unload the bin's product, use the crank to open the slide gate chute assembly. The emptying rate of the bin is determined by how far the slide gate is opened. Optional permanent auger mounts and auger boots to enclose the unloading chute can be ordered to complement the functioning of your storage bin. The slide gate assembly is optional on Meridian Manufacturing Inc.'s feed bin line.
2. When unloading fertilizers, make sure that the product does not cake on one side, cling to the side of the bin, or empty on the other side. This will usually occur when a hot product such as mixed potash is loaded into the bin and then cools, causing a moisture build-up due to condensation or any other product that has bridging.

If this happens, an uneven stress is generated on the bin structure and could cause structural damage. In most cases, banging the side of the bin with a rubber mallet will break the material loose. Failing this, use a long pole or piece of wood through the inspection manhole to break the caked material free.
3. Do not crawl under the opened unloading chute to inspect for a suspected blockage. This is an unsafe practice. Caked or impacted product could suddenly break loose and cause facial, body and/or eye injury.
4. Do not attempt to enter the hopper bin through the top loading hatch. This opening is designed for loading the bin only and not for human entry.
5. Use the inspection manway only for entry into the bin and only when the bin is empty for cleaning purposes.
6. If you enter the bin, make sure that there is no possibility that either the loading or unloading auger could be started up. Lock-Out-Tag-Out the power sources for the augers and have a responsible, trained person close at hand to keep unauthorized individuals away from the work area.
7. Enter the empty bin with extreme caution and wear protective clothing, goggles for eye protection and a properly filtered respirator mask for lung protection. It is also good safety practice to connect a safety line to yourself and a secure attachment point outside the bin before entering the enclosed area.

5.5 OPTIONAL FEATURES/EQUIPMENT

A variety of optional features or equipment is available for use with the Hopper Bin. Contact your dealer, distributor or the factory for more details.

5.5.1 MERIDIAN AIRMAX™

Grain normally is harvested when its moisture content is low enough to allow for long term storage without a deterioration in grain quality or spoilage. Unfortunately, farmers have always faced crop maturity variations, adverse weather conditions and labor shortages that require harvesting before the moisture content of the grain will allow safe, long term storage. Storage problems can range from localized hot spots to complete deterioration and spoilage. Depending on the moisture content, the grain can go down from premium quality until, in the worst case, it is unfit for both human and animal consumption.

A variety of grain drying methods and technologies have been developed over the years to eliminate grain spoilage during storage. The fastest but by far the most expensive technique is using a gas fired batch dryer to reduce moisture content of the grain before it is placed in storage.

Another less expensive alternative has been developed over the years. It is called aeration and involves forcing outside air into the bottom of the grain bin to reduce moisture content, lower the temperature of the material and maintain grain quality. No external heating is required, but a low temperature heater to aid dryer in adverse weather conditions is needed using this method. The only extra energy is that needed to force air through the grain. A variety of methods and techniques have been tried in an attempt to obtain an even distribution of air flow through the grain for uniform cooling and drying. Some work well; others have limitations.

Meridian Manufacturing Inc. offers an optional ducting system that is factory installed or the small version can be installed in the field. The internally mounted rocket or shuttle system provides uniform air flow and drying throughout the bin. The innovative hollow duct design is formed by a self-cleaning perforated metal screen to allow air to disperse through the grain in all directions.

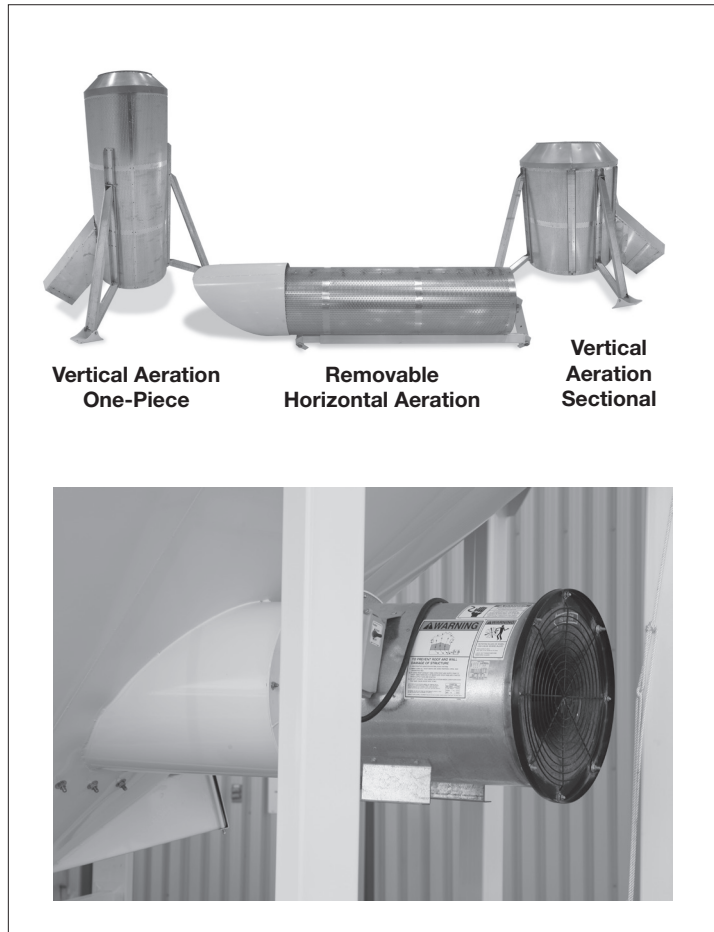


Fig. 6 MERIDIAN AIRMAX™

Each customer can choose which ducting system they want for their storage system. Some must be ordered from and installed at the factory and others can be field installed. Review the tables and select the system that works best with your application.

5.5.2 LADDERS

Each bin is equipped with a ladder that allows the user to access the top of the bin. Select and utilize the ladder appropriate for your application.

1. **Access Ladder:**

Each Bin is designed and built with a ladder that reaches to the loading hatch.

2. **Ladder Cage:**

This OSHA approved cage surrounds the ladder to reduce the chance of falling.

3. **Safety Section:**

The access ladder has a moveable safety section located at ground level. This is designed to slide up out of reach of children and latch into place. Make sure that this safety section is always raised and latched into place when the bin is not being used to prevent children and unauthorized personnel from climbing up the access ladder.

4. **Inside Ladder (Not Shown):**

This inside ladder provides access to the inside of the Bin and is located next to the access manhole in the roof.



Ladder



Cage



Safety Section

5.5.3 MANHOLES

Manholes are available in the roof as an inspection port and can also be used as an entrance to the interior of bin and may have an interior ladder.

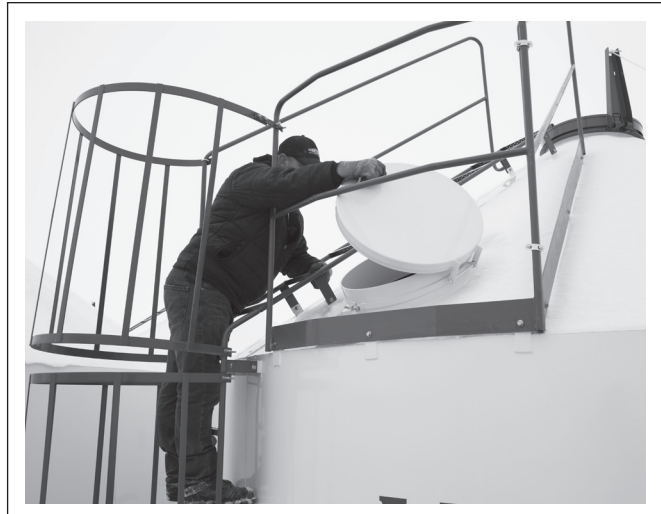


Fig. 8 MANHOLE

5.5.4 ACCESS MANWAY

This access hole is located in the bottom cone and provides access to the interior of the Bin. Do not use it to dislodge bridged material inside the Bin.



Fig. 9 MANWAY

5.5.5 BEAN LADDER

This ladder hangs in the centre of bin and directs the material to flow down the ladder to the bottom of bin to reduce damage to seed. It is particularly recommended for pulse crops of all kinds and reduces splits from handling.

NOTE

Bean ladder must be removed if and when the bin is used for fertilizer storage or any other product that is prone to bridging.

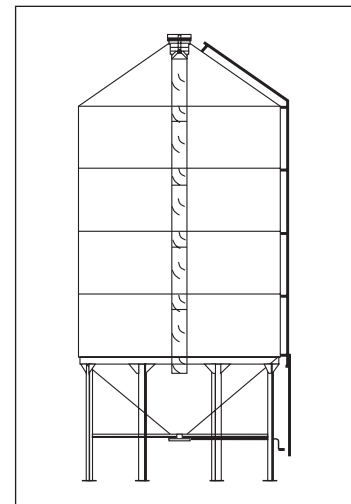


Fig. 10 BEAN LADDER

5.5.6 AUGER BOOT

This assembly allows an auger to fit into the bottom cone of the Bin and provides for easy and convenient unloading.

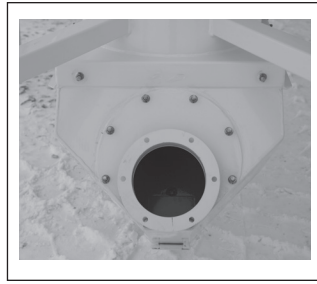


Fig. 11 AUGER BOOT

5.5.7 PAIL CHUTE

This assembly allows someone to take a small sample from the Bin without spilling any material. It is equipped with a small hand-operated slide gate to control the size of the sample. A pail works well to collect the sample.



Fig. 12 PAIL CHUTE

5.5.8 POKE HOLE

This access hole allows an operator to get a pole or stick into the Bin to dislodge any bridged material. It is a convenient way to eliminate bridging without entering the Bin.



Fig. 13 POKE HOLE

5.5.9 LEG EXTENSIONS

Leg extensions are available to raise the Bin up to allow for special loading or unloading equipment appropriate for your application.

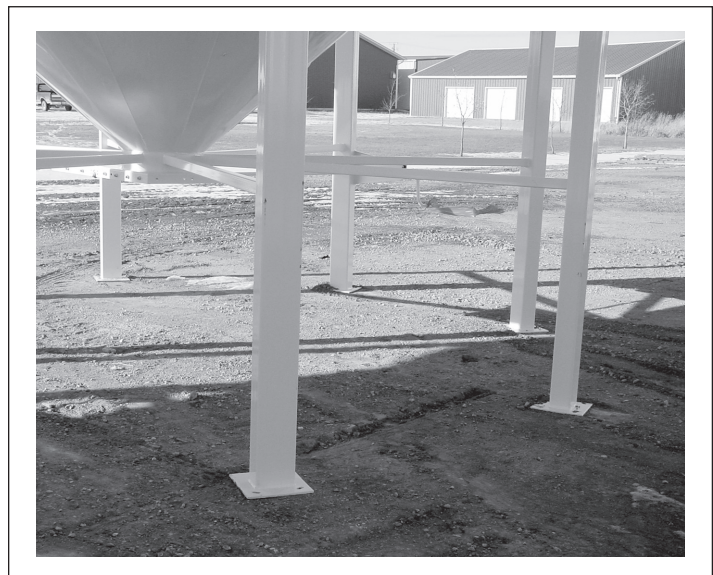


Fig. 14 LEG EXTENTIONS

5.5.10 Level ALERT Bin Level Indicator

Level ALERTs are available and installed on the sidewall of the bin. They turn a fluorescent yellow when the product level inside the bin reaches that point. Level ALERTs can be installed at any time, and are available with an optional proximity switch to control lights, alarms, etc.

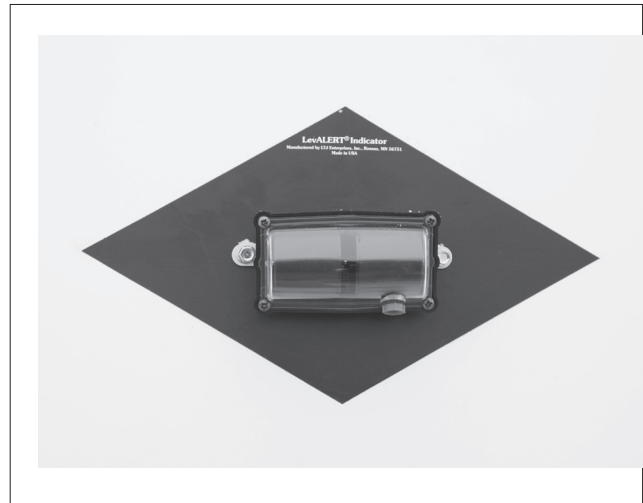


Fig. 15 Level ALERT bin level indicator

5.5.11 VIEW GLASSES

View Glass(es) are available and installed into the sidewall to allow viewing of material inside. View Glasses are best ordered and installed from the factory.



Fig. 16 VIEW GLASSES

5.5.12 PAINT (INTERNAL)

All fertilizer bins come standard with Polyester powder coat finish interior. This powder coat finish protects the interior metal surface when coming in contact with corrosive materials. If fertilizer, potash or any other corrosive material will be placed in the bin, it must have the powder coat finish paint on the inside to prevent damage to the metal surface.

Always inspect the interior surface for damage before filling with corrosive material. Clean and repaint if any damage is found. Warranty will be null and void on any unpainted or poorly maintained bin.

IMPORTANT

Always follow all paint application safety instructions when maintaining the bin.

5.5.13 OTHER OPTIONS

1. Touch-Up Paint.
2. Grain or Feed Boot.
3. Pneumatic Fill System.
4. Vented and Non-Vented Top Lid.
5. View Glass.
6. Safety Fill.
7. Transitions.
8. 12", 14", and 18" Gooseneck Vents.
9. OPI-One Sensors and Cables.
10. OPI-One Monitor.
11. Skids.
12. Level Alert.
13. Fan Mounting Bracket.
14. Lift Hooks.

6 MAINTENANCE



MAINTENANCE SAFETY

1. Read operator's manual before performing and maintenance work.
2. Clear the area of bystanders, especially small children.
3. Lock-out tag-out all power sources before entering bin or performing maintenance work on bin or auxiliary equipment.
4. Use a safety line whenever entering the bin.
5. Use a respirator with a fresh air supply whenever repainting interior of bin. Always have a helper available to assist with the work.
6. Wear the appropriate safety gear while performing maintenance work on bin or auxiliary equipment.

By following a careful service and maintenance program for your bin, you will enjoy many years of trouble-free service.

The recommended maintenance items include but are not limited to:

1. **Inspection:**
When the bin is empty, periodically inspect the inside of a painted bin for bare metal areas where the paint has worn. A special epoxy paint kit is available and it is highly recommended that only this type of paint be used. Remember to exercise all the cautionary points covered in the safety sections of this manual.
2. **Re-Painting:**
It is especially necessary that any bare metal be painted before storing fertilizer or any other corrosive commodities. Exposed metal will corrode quickly. A special epoxy repair kit for the interior is available through your Meridian dealer. Exterior enamel paint kits are also available to touch up scrapes and minor dent marks.
3. **Pad Inspection:**
Check the foundation conditions regularly. Cracks that are more than 1/8 inch wide in the concrete slab indicate significant movement. Always consult with a professional engineer when foundation problems arise. If severe cracking exists, slab levels should be taken to determine whether any area of the slab is sinking independently. Subsoil conditions should be monitored to ensure against bearing capacity losses.

7 SPECIFICATIONS

Multi-Purpose Fertilizer Bins

Model #	Bushels	Cubic Feet	Imp. Tons	Metric Tons	Bin Height	Min. Auger
12' Diameter Bins - 45 Degree Bottom Cone						
1205	806	949	29	27	16' 8"	36'
1208	1095	1288	40	36	19' 8"	36'
1210	1287	1514	47	43	21' 8"	41'
1212	1479	1740	54	49	23' 8"	46'
1215	1768	2080	64	58	26' 8"	51'
14' Diameter Bins - 45 Degree Bottom Cone						
1410	1826	2149	67	60	23' 3"	41'
1412	2088	2457	76	69	25' 3"	46'
1415	2481	2918	90	82	28' 3"	51'
1417	2742	3226	100	91	30' 3"	56'
1420	3135	3688	114	104	33' 3"	61'
16' Diameter Bins - 40 Degree Bottom Cone						
1610	2410	2836	88	80	23' 11"	41'
1612	2751	3237	100	91	25' 11"	46'
1615	3264	3840	119	108	28' 11"	51'
1617	3606	4242	132	119	30' 11"	56'
1620	4119	4845	150	136	33' 11"	61'
1625	4973	5851	181	165	38' 11"	71'
1630	5828	6856	213	193	43' 11"	71'
18' Diameter Bins - 40 Degree Bottom Cone (FOB Winkler)						
1810	3161	3719	115	105	25' 6"	46'
1815	4242	4991	155	140	30' 6"	51'
1820	5324	6263	194	176	35' 6"	61'
1825	6405	7536	234	212	40' 6"	71'
15'6" Diameter Bins - 40 Degree Bottom Cone (Available for NW USA Destinations)						
1510	2241	2636	82	74	23' 9"	41'
1512	2561	3013	93	85	25' 9"	46'
1515	3043	3580	111	101	28' 9"	51'
1517	3363	3957	123	111	30' 9"	56'
1520	3845	4523	140	127	33' 9"	61'
1525	4646	5466	169	154	38' 9"	71'
1530	5448	6410	199	180	43' 9"	71'

Liquid Bins

Model #	Imp. Gallons	U.S. Gallons	Bushels	Cubic Feet	Imp. Tons	Metric Tons	Bin Height	Min. Auger
1212L	10878	13074	1479	1740	54	49	23' 8"	46'
1412L	15354	18449	2088	2457	76	69	25' 3"	46'
1612L	20230	24305	2751	3237	100	91	25' 11"	46'
1615L	24000	28832	3264	3840	119	108	28' 11"	51'
1617L	26514	31850	3606	4242	132	119	30' 11"	56'
1620L	30284	36378	4119	4845	150	136	33' 11"	61'
15'6" Diameter Bins - 40 Degree Bottom Cone (Available for NW USA Destinations)								
1512	18770	22542	2561	3013	93	85	25' 9"	46'
1515	22296	26777	3043	3580	111	101	28' 9"	51'
1517	24647	29600	3363	3957	123	111	30' 9"	56'
1520	28173	33834	3845	4523	140	127	33' 9"	61'

Grain Max

Model #	Bushels	Cubic Feet	Bin Diameter	Bin Height	Min. Auger
GM1000	1095	1288	12'	19' 8"	36'
GM2300	2301	2707	14'	26' 3"	46'
GM3000	3264	3840	16'	28' 11"	51'
GM4000	4119	4845	16'	33' 11"	61'
GM5000	4973	5851	16'	38' 11"	71'
GM6000	5828	6856	16'	43' 11"	71'
18' Diameter Bins - 40 Degree Bottom Cone (FOB Winkler)					
GM5300	5324	6263	18'	35' 6"	61'
GM6400	6405	7536	18'	40' 6"	71'
15'6" Diameter Bins - 40° Bottom Cone (Available for NW USA Destinations)					
GM3000	3043	3580	15'6"	28' 9"	51'
GM4000	3845	4523	15'6"	33' 9"	61'
GM5000	4646	5466	15'6"	38' 9"	71'

Feed Bins

Model #	Bushels	Cubic Feet	Imp. Tons	Metric Tons	Bin Height	Min. Auger
7 Diameter Bins - 60 Degree Bottom Cone						
705	225	300	6	5.4	14' 3"	25'
708	353	415	8.3	7.5	17' 3"	28'
710	419	492	9.8	8.9	19' 3"	31'
8 Diameter Bins - 55 Degree Bottom Cone						
808	462	543	10.9	9.9	17' 6"	28'
810	547	644	12.9	11.7	19' 6"	31'
812	633	744	14.9	13.5	21' 6"	35'
9 Diameter Bins - 55 Degree Bottom Cone						
910	712	838	16.8	15.2	20' 6"	35'
912	820	965	19.3	17.5	22' 6"	37'
915	983	1156	23.1	21	25' 6"	41'
10 Diameter Bins - 55 Degree Bottom Cone						
1010	903	1063	21.3	19.3	21' 8"	35'
1012	1037	1220	24.4	22.1	23' 8"	25'
1015	1237	1455	29.1	26.4	26' 8"	43'

Steep Cone

Model #	Bushels	Cubic Feet	Imp. Tons	Metric Tons	Bin Height	Min. Auger
12' Diameter Bins - 55° Bottom Cone						
1205-55	889	1045	32	29	18' 10"	36'
1208-55	1177	1385	43	39	21' 10"	41'
1210-55	1369	1611	50	45	23' 10"	41'
1212-55	1562	1837	57	52	25' 10"	46'
1215-55	1850	2176	67	61	28' 10"	51'
14' Diameter Bins - 55° Bottom Cone						
1410-55	1957	2302	71	65	25' 11"	46'
1412-55	2219	2610	81	73	27' 11"	51'
1415-55	2611	3072	95	86	30' 11"	56'
1417-55	2873	3380	105	95	32' 11"	61'
1420-55	3266	3842	119	108	35' 11"	61'
16' Diameter Bins - 55° Bottom Cone						
1610-55	2678	3150	98	89	28' 1"	51'
1612-55	3020	3552	110	100	30' 1"	56'
1615-55	3532	4156	129	117	33' 1"	61'
1617-55	3874	4558	141	128	35' 1"	61'
1620-55	4387	5161	160	145	38' 1"	71'
1625-55	5241	6166	191	173	43' 1"	71'
1630-55	6096	7172	222	202	48' 1"	81'
15'6" Diameter Bins - 55° Bottom Cone (Available for NW USA Destinations)						
1510-55	2484	2923	91	82	27' 11"	51'
1512-55	2805	3300	102	93	29' 11"	56'
1515-55	3286	3866	120	109	32' 11"	61'
1517-55	3607	4244	132	119	34' 11"	61'
1520-55	4088	4810	149	135	37' 11"	71'
1525-55	4890	5753	178	162	42' 11"	71'
1530-55	5692	6697	208	188	47' 11"	81'

Calculations

Bushel capacities are approximate
 Feed bin capacities are based on 40 lbs/ft³.
 All fertilizer bins, steep cone bins and liquid bins capacities are based on 62 lbs/ft³.

- To select the most appropriate bin size for your storage, please follow these steps:
- Determine product density (lbs/ft³).
 - Convert the total tonnage being stored to lbs, then divide by the density. The result is the cubic foot capacity you require.

Example - You need to store 100 MT of urea fertilizer with a density of 48 lbs.
 $100 \times 2204 = 220,400 / 48 = 4592$ (Min. ft³ required)
 Best model selection would be a 1620 or 1815.

- To calculate a bins holding capacity of a specific product, follow these steps:
- Determine product density (lbs/ft³).
 - Multiply the bins cubic foot capacity by the product density, then divide by 2204.

Example - Your fertilizer blend weights 57 lbs/ft³ and your purchasing a model 1625 fertilizer bin.

Model 1625 = $5851 \text{ ft}^3 \times 57 \text{ lbs} = 333,507 \text{ lbs} / 2204 = 151 \text{ MT}$. Your new 1625 will hold about 151 MT of your specific fertilizer blend.



ATTENTION DEALERS:

You can register your products online through the Dealer Login: <http://dealers.meridianmfg.com/login/>

Meridian Manufacturing Inc. "Warranty Registration Form": It is mandatory to complete this form and return to the manufacturer in order to qualify for future warranties that may arise; knowingly falsifying information on this form will result in the voiding of the product warranty.

Dealer Information	Customer Information
Name: _____	Name: _____
Address: _____	Address: _____
City, State, Code: _____	City, State, Code: _____
Phone: _____	Phone: _____

Note; registering a product in multiple entry format is only allowed when; the product has the same Model # and the same dealer, however **each serial number must be legibly listed for each unit.** Delivery dates for a multiple entry must be within a 1 month time frame.

Product Information: _____

Model #: _____

Serial Number #: _____

Invoice Date: _____

***Warranty Acknowledgement *** "The Product Warranty" along with the "Operator's Manual" for this product purchase has been reviewed and understood by the end user.

Date: _____ **Signature:** _____

Important: Please send this form to the Meridian Manufacturing Location which built this product being registered; if you require further assistance call you're Dealer or the Meridian Manufacturing outlet nearest to your location.

We want to thank you for purchasing a Meridian manufactured product. Whether this is your first Meridian purchase or you have been a customer for years; you are now part of the Meridian community of customers and we appreciate your business.

It is important that you now complete the product registration information and this form indicating you have received delivery. This registration and information is necessary to ensure you have access to warranty and product updates in the event it be required in the future.

Registration can be completed by using this form or visiting your dealer who will complete the form online. You will be given access to the Meridian Community and become eligible for updates, special offers and prizes.

Again thank you for choosing Meridian.

MERIDIAN MANUFACTURING INC.

is North America's leading storage expert with almost
50 years specializing in hopper tank storage.



AGRICULTURAL



INDUSTRIAL



OIL & GAS

Camrose Office
4232 - 38 St.
Camrose, AB T4V 4B2
PH: 780.672.4516
TF: 800.830.2467
FX: 780.672.4759

Lethbridge Office
3125 - 24 Ave. N.
Lethbridge, AB T1H 5G2
PH: 403.320.7070
TF: 800.661.1436
FX: 403.320.7579

Storm Lake Office
2902 Expansion Blvd.
Storm Lake, IA 50588
PH: 712.732.1780
TF: 800.437.2334
FX: 712.732.1028

Winkler Office
Box 760, 275 Hespler Ave.
Winkler, MB R6W 4A8
PH: 204.325.7883
TF: 800.665.7259
FX: 204.325.5556

MERIDIAN

www.meridianmfg.com