

X6 PREMIUM

420 - 430



MCCORMICK





McCORMICK X6 PREMIUM, INNOVATIVE DESIGN FOR UNMATCHED COMFORT AND PRODUCTIVITY

Each McCormick tractor reflects the passion and dedication of those involved in designing, testing and producing this incredible line-up of tractors. The X6 Series tractors make a statement with power, versatility, and efficiency.

McCormick has designed and built the X6 series with an ambitious goal: to create a series of mid-range tractors that have the reliability and versatility to be able to respond to the real needs of every farm.

Born from the extensive experience gained in the field by our engineering team, the X6 is a tractor designed to be highly versatile in any work situation. The series offers two different types of configurations: Standard and Premium.

The aggressive and modern design of the X6 is unmistakably one of the latest generations of McCormick tractors, designed to give the machines a compact and powerful look. The four-post cab has been designed to provide the operator with complete visibility and superior comfort.

HIGHLIGHTS

- › Manufactured, Designed, and Engineered by McCormick
- › 4.5 liter BETAPOWER Engine
- › 36 x 12-Speed Gearbox
- › Hydraulic Power Shuttle
- › Push-Button 4WD and Differential Lock
- › 4WD Front Axle
- › Heavy Lifting 3-Point Hitch
- › Deluxe Cab with Completely Flat Foot Deck
- › Digital Front Dash Display
- › 29 gpm (110 lpm) Superior Hydraulic System
- › Instructor's Seat
- › 25 mph (40 kph) Transport Speed
- › Fully locking front and rear differentials
- › Closed Center Hydraulic System
- › 540 and 1000 speed PTO standard equipment

| MODEL | MAX HP | MAX PTO HP |
|---------------|--------|------------|
| X6.420 | 121 | 109 |
| X6.430 | 133 | 121 |



ENGINE

BETAPOWER, 4.5L

HOOD DESIGN

FAMILY STYLE

CAB

DELUXE COMFORT

REAR HITCH

10,450 LB LIFT

REAR PTO

540/1000

FRONT AXLE

4-WHEEL DRIVE

TRANSMISSION

POWER SHUTTLE

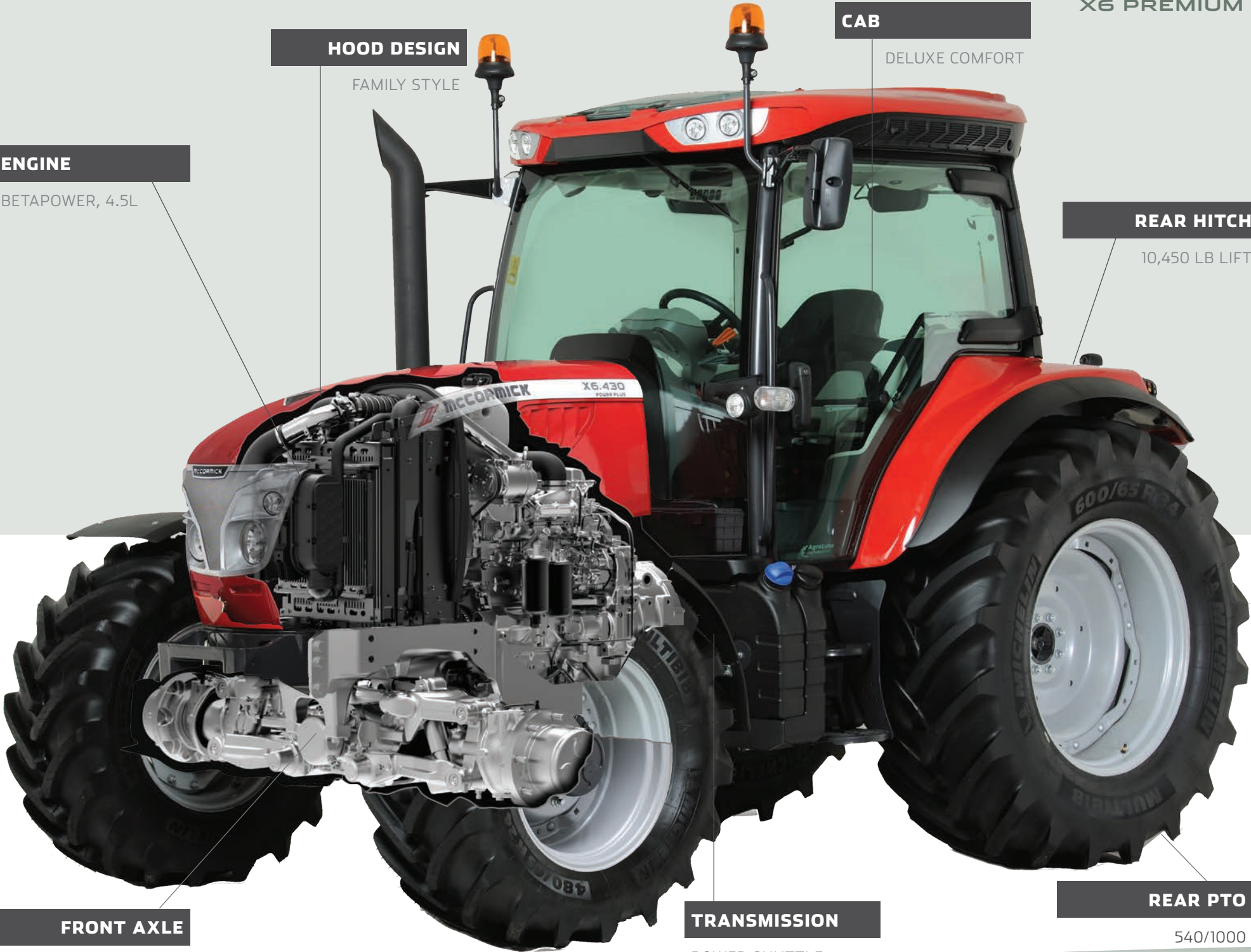

DELUXE CAB: YOUR LUXURY WORK ENVIRONMENT

The X6 series cab features a four-post frame with flat foot deck, large rear hinged doors that provide ease of access to the driving position, and a one-piece panoramic widescreen that gives all-round visibility. The deluxe upholstered swivel seat with dynamic air suspension system combined with a heavy duty HVAC system creates a comfortable interior for less fatigue during long working days.

The telescopic tilt-adjustable steering wheel is designed to tilt with the instrument panel. The cushioned instructor's seat is adjustable for comfort, and fold away when not in use. The tilt and telescopic steering with integrated front dash and intuitive layout of controls keep the driver informed and make operation easy. The cab sits up high on the tractor chassis to offer excellent visibility in all directions.



X6 Premium models feature our deluxe cab with a spacious 4 post design. Both doors open widely for easy access from either side.



Most major tractor controls are integrated into the right hand console within easy reach of the operator. Positioned for quick identification and simple operation, the intuitive layout ensures maximum productivity.





MCCORMICK

HIGHLIGHTS

- › Easy Access
- › Spacious 4-Post Design
- › Roofline Window for Increased Loader Visibility
- › Deluxe Air Suspended Seat
- › Heavy Duty HVAC System
- › Hide Away Instructor's Seat
- › Ergonomic Controls
- › Cab Suspension Available
- › Pressurized Cab for Acoustic Insulation
- › Radio and Sound System Standard



Panoramic Visibility

The structure of the cab has 4 posts with completely flat foot deck and rear hinged doors. These features allow for a perfect 360 degree field of view for the operator.



Exceptional Rear View

Thanks to the large rear window and large size of the side mirrors, the operator is able to work comfortably and easily with an complete rear view.

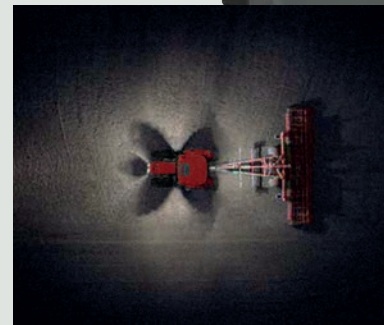

All Day Lighting

The ensure the best productivity with maximum safety, premium halogen lights can illuminate the field for operators that can't stop at sunset.



Ergonomic Controls

All controls are laid out along the right hand arm rest for easy access & an unobstructed view for the operator.



ROOFLINE WINDOW

The sunroof allow the operator to work easily with the front loader. It can be opened for ventilation and also has an adjustable sun shade to protect the operator from direct light and reflections.



HVAC SYSTEM

Simple operation and access to the controls for the heavy duty HVAC are integrated into the upper dash of the cab. Operators are able to control their temperature as they please.



BLUETOOTH RADIO

The premier radio system in X6 cabs allows for Bluetooth/MP3 radio connection. Operators can listen to entertainment via their MP3 player or Bluetooth compatible device, AUX connector, or even USB drive. This system also allows hands-free calling for increased convenience and safety.



ADDED COMFORTS

On the left-hand console there is a chilled storage compartment. Temperature is maintained via an additional air conditioning vent located inside the console, which can also be turned off if needed.



Pro-Drive Transmission: Maximum Efficiency

The Pro-Drive Transmission features 36 forward and 12 reverse speeds in 3 ranges with 3 powershift gears in each range. Incorporated is electronic range shifting and a separate, electro-hydraulic power shuttle. In addition, a creeper gearbox is available as an option on the X6.430, providing additional 12 forward speeds and 4 reverse speeds.

The Pro-Drive transmission is designed to ensure the operator has the right speed for every application, and offers a top speed of up to 25mph (40kph).

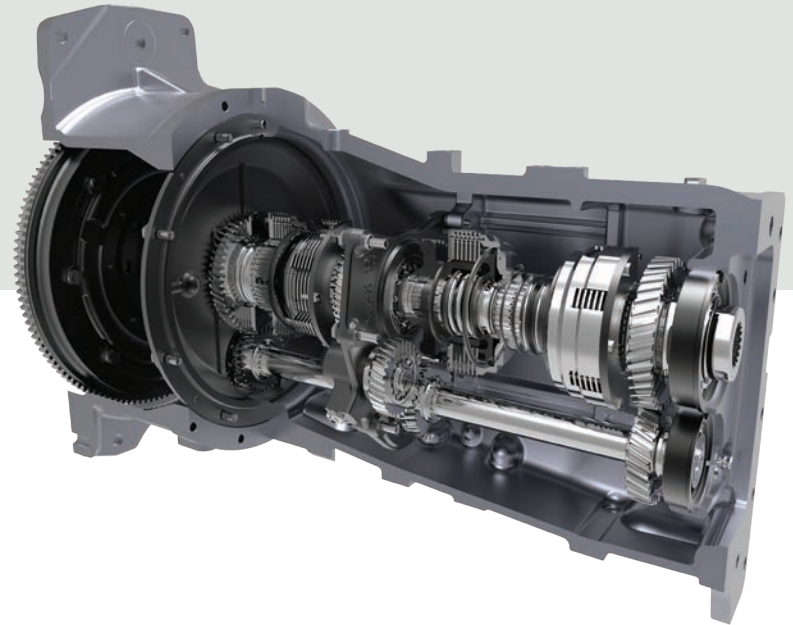



BETAPOWER PERFORMANCE FOR THE TOUGHEST DEMANDS

The X6 tractors are powered by a 4.5 liter, 4-cylinder BETAPOWER clean diesel engine with advanced SCR technology that delivers power and performance while meeting the EPA's strict emissions requirements. The electronic common rail fuel injection system, along with turbocharging and intercooling, helps to generate high, sustained torque to keep the wheels turning and get work done. The engine also features the 'PowerPlus' system. PowerPlus delivers extra horsepower and torque in PTO and transport operations to power through tough conditions while maintaining speed and productivity.

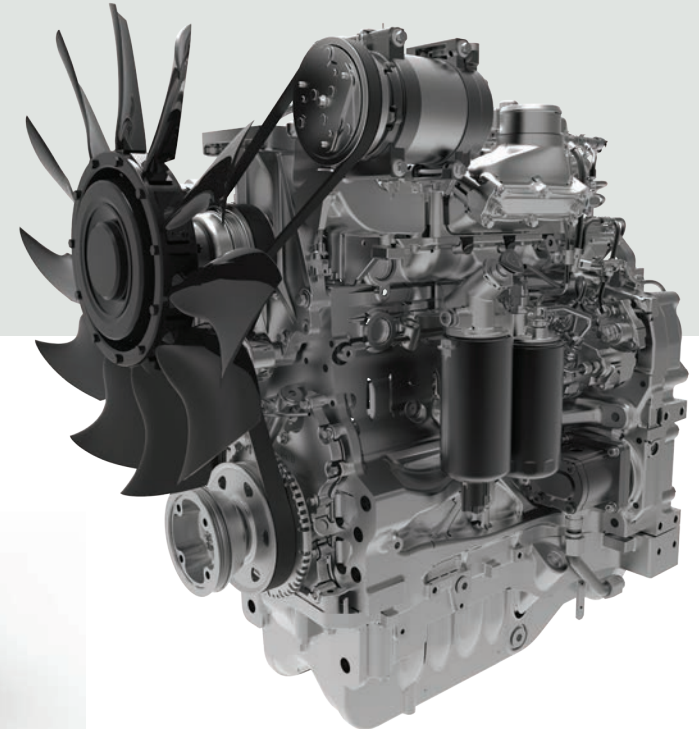



POWERFUL HYDRAULICS, HITCH,
AND PTO FOR **EVERY APPLICATION**

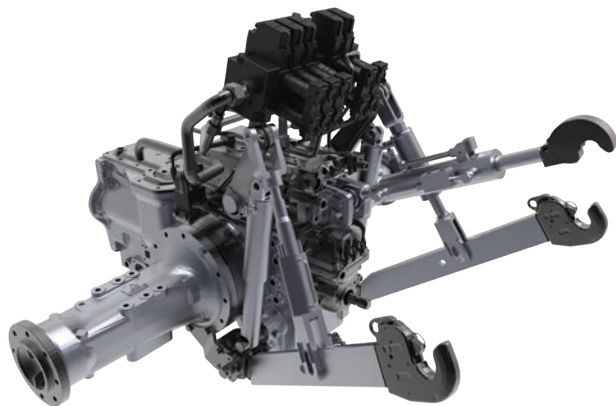

An ASABE Category 2 rear 3-point hitch operates electronically using simple controls in the right hand console and has a massive 11,905 lb (5400 kg) lift capacity for handling large mounted implements.

X6 tractors offer both 540 and 1000 RPM PTO speeds to power a wide variety of implements. A wet disc PTO clutch engages with the press of a button for smooth PTO start-up. A simple hand lever near the seat selects the PTO gear.

External rear fender buttons on both sides of the tractor allow the operator to start and stop the rear PTO, as well as raise and lower the 3-point hitch.



The closed center PFC hydraulic system uses a variable displacement pump to provide up to 29 gpm (110 lpm) of oil flow to the implement system. The advantage of a closed center system is that it delivers oil flow instantly and on demand, conserving engine power when no oil is needed. A separate 10 gpm (38 lpm) gear pump is dedicated to the steering system.

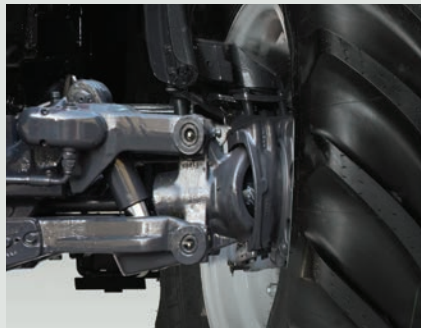

Traction, Maneuverability, and Comfort

The standard 4wd front axle offers a high 55-degree steering angle for excellent maneuverability in tight spaces. Push-button 4wd engagement increases traction and pulling power for better field performance. The durable wet disc clutch and outboard planetary final drives ensure a long service life on the farm. A fully locking front differential engages simultaneously with the rear differential, at the push of a button, to further increase traction. Integrated front axle brakes are standard equipment to improve stopping power during transport work for safety.

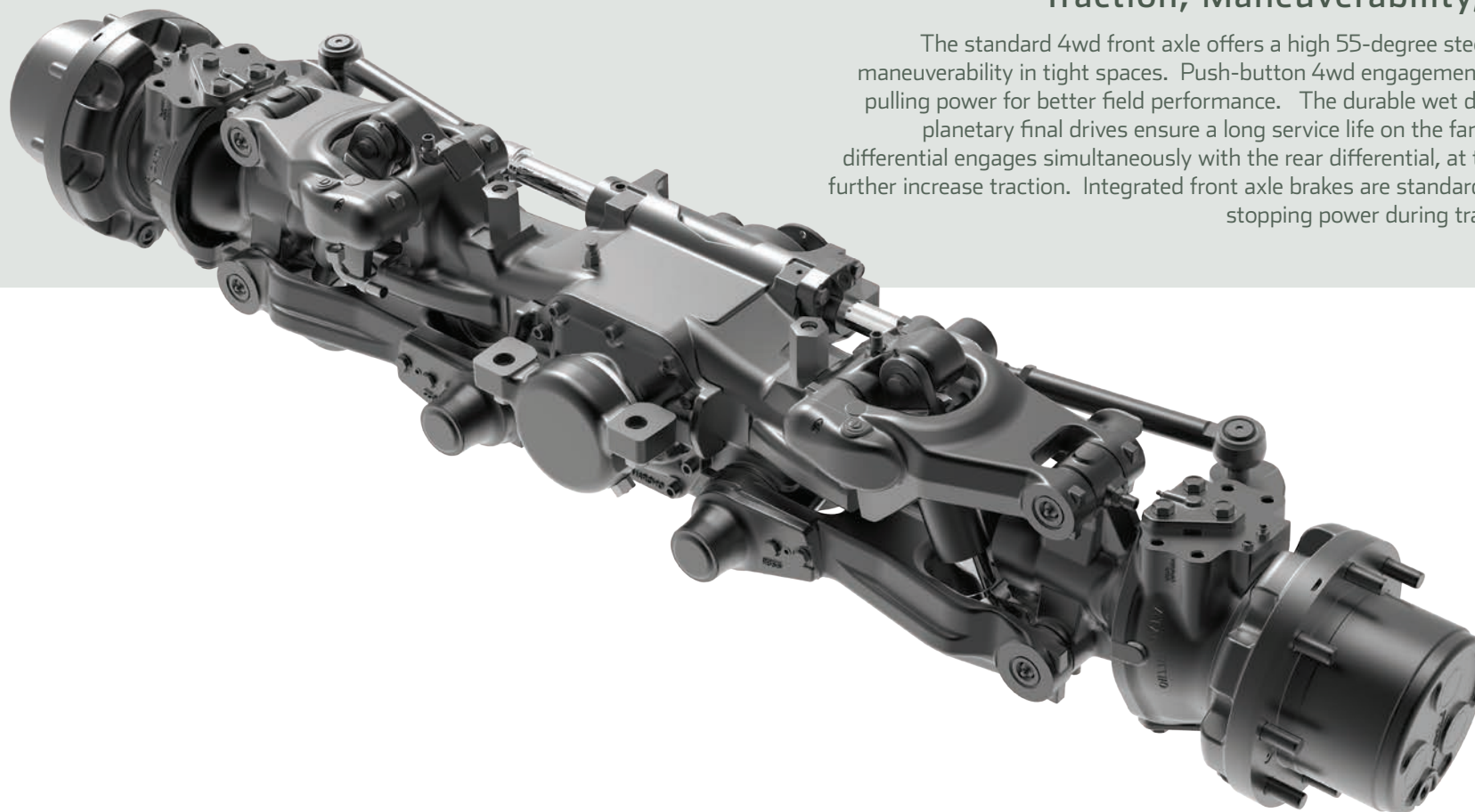



QUICK MAINTENANCE TO GET YOU BACK IN THE FIELD

1. Top off your engine oil without the need to open the hood. The cap is located in the lower part of the engine.
2. The single-piece hood fully opens to allow complete accessibility.
3. The engine air filter is positioned so that it can be easily cleaned or replaced.
4. Radiators have a fan-shaped opening system that allows a quick, simple, and accurate cleaning.
5. Fuel and AdBlue tanks are positioned to allow quick refueling.
6. The cabin air filter is easily accessible for simple maintenance.
7. The oil level of the transmission hydraulic system can be easily controlled via the rod cap on the rear of the tractor.
8. Top off you wind shield wiper fluid at the rear of the cab.



The X6 Series is a true product of reliability and productivity. It comes equipped with many solutions designed to simplify and speed up the maintenance of the tractor.

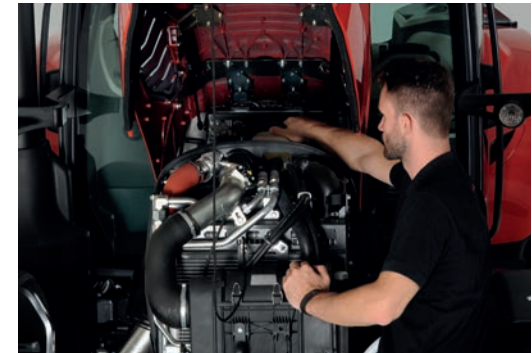



MCCORMICK PARTS AND SERVICE: YOUR AFTER SALES RESOURCE

Even in spare parts and after-sales services, the McCormick brand is always a symbol of quality and reliability. Original McCormick parts, manufactured according to the highest quality standards, ensure the best performance and safety of each tractor because they are developed by the same team that designs and builds our tractors. Parts are delivered to our dealers quickly and efficiently, with each piece being

guaranteed for 12 months. Service is carried out by specialized personnel equipped with the most advanced diagnostic technology. Our competent service team is knowledgeable, reliable and oriented to problem solving.

Choosing McCormick means choosing excellence.



PARTS & SERVICE



FRONT END LOADERS

| Loader Model | L41 | L46 | L51 | L56 |
|---|-------------------|-----------------|-------------------|-----------------|
| Loader Type | Non-Self Leveling | Self Leveling | Non-Self Leveling | Self Leveling |
| Max. Lift Height at Pivot Pin | 149 (3790) | 149 (3790) | 159 (4060) | 159 (4060) |
| Lift Capacity to Max. Height 31.5" (800 mm) Forward of Pivot Pin | 3,440 (1560) | 4,230 (1920) | 2,870 (1300) | 4,370 (1980) |
| Breakout Force from Ground Level 31.5" (800 mm) Forward of Pivot Pin | 7,740 (3510) | 7,410 (3360) | 7,540 (3420) | 7,430 (3370) |
| Lift Capacity to Max Height at Pivot Point | 5,420 (2460) | 3,770 (1710) | 4,520 (2050) | 3,790 (1720) |



| Tractor Model | | X6.420 | X6.430 |
|--|--|--|-----------|
| Engine | | | |
| Rated Engine HP @ 2200 RPM | HP (kW) | 111 (82) | 121 (89) |
| Rated PTO HP @ 2200 RPM | HP (kW) | 101 (74) | 111 (82) |
| Max. Engine HP @ 1900 RPM <i>with power plus**</i> | HP (kW) | 121 (89) | 133 (98) |
| Max. PTO HP @ 1900 RPM <i>with power plus**</i> | HP (kW) | 109 (81) | 121 (89) |
| Max. Engine Torque @ 1500 RPM <i>with power plus**</i> | lb ft (Nm) | 367 (498) | 405 (549) |
| Engine Type | BETAPOWER diesel engine; Tier 4 using advanced Selective Catalytic Reduction (SCR) technology | | |
| Engine Size | 4.5 Liter 4-cylinder | | |
| Fuel / DEF Capacity | gal (liter) | 47.6 (180) / 6.6 (25) | |
| Drive Train | | | |
| Standard Transmission | 36 x 12 speeds: hydraulic power shuttle; 3-speed power shift; 25 mph (40 kph) transport speed | | |
| Optional Transmission | none | 48 x 16 speeds with creeper gear | |
| Clutch | Wet multi-disc main clutch | | |
| Rear Axle | Internal planetary final drives; heavy duty wet disc brakes; flange axle | | |
| Differential Lock | Front and rear fully locking differentials; electronic control; hydraulic engagement | | |
| 4wd Front Axle | Electro-hydraulic engagement with integrated front axle brakes | | |
| Hydraulics, 3-point Hitch, PTO | | | |
| Hydraulic System | gpm (lpm) | Closed Center PFC: dedicated steering pump 10 (38), variable implement pump 29 (110) | |
| Rear Remote Valves | 3 spool valves | | |
| Rear 3-point Hitch Type | Category 2; electronic control; rear fender controls | | |
| Rear 3-point Lift Capacity @ Hitch | lb (kg) | 11,905 (5,400) | |
| Rear PTO | 540 / 1000 RPM; electro-hydraulic engagement; rear fender controls | | |
| Operator's Area | | | |
| Cab | Large 4-post structure; 2 doors; flat foot deck; heavy duty HVAC; premium sound system (suspension option available on X6.430) | | |
| Seat and Front Dash | Deluxe air suspended seat; tilt and telescopic steering wheel; instructor's seat | | |
| Wheelbase | in (mm) | 100 (2,540) | |
| Height Over Cab <i>with standard wheel equipment</i> | in (mm) | 110.4 (2,805) | |
| Overall Length <i>with front weights</i> | in (mm) | 173 (4,400) | |
| Base Weight <i>without ballast</i> | lb (kg) | 10,360 (4,700) | |

*Manufacturer's Calculated Estimates. +/- 5% tolerance.

**PowerPlus is available only when certain operating conditions are met.



McCormick North America
www.McCormickNA.com

updated: 04.23.2019

