

**MacDon®**



## ***C Series Clinic Handout***

***The Harvesting Specialists.***

# Table of Contents

---

<b>Advantages &amp; Features</b> .....	3
The MacDon C Series Advantage .....	3
More Features & Advantages .....	4
<b>Setup &amp; Settings</b> .....	5
Header Operating Speed .....	5
Row Unit Angle .....	5
Snouts .....	5
Checking Snapping (Deck) Plate Clearance .....	6
Vine Knife .....	7
Gathering Chains .....	7
Auger Setup .....	7
Chopping Mechanisms Engage / Disengage .....	8
Lubrication Table .....	9
Maintenance / Lubrication .....	10
Gathering Chains .....	10
Gathering Chain Timing .....	11
Chopper Knives .....	12
Auger Drive Chains .....	12
Stalk Chopper Gearboxes .....	12
Snapping Unit Gearboxes .....	13
Input Gearboxes .....	13
Header Drive Shafts .....	13
Snapping Rolls .....	14
Snapping Rolls Knife Spacing Adjustments .....	14
Folding Corn Header .....	15
<b>Options</b> .....	16
Rotary End Dividers .....	16
Tall End Dividers .....	16
AHHC .....	16
Upper Ear Savers .....	17
Stubble Stompers .....	17
In-field Adjustments for Challenging Conditions .....	18
Ear Savers .....	18
<b>Notes</b> .....	19

# Advantages & Features

## The MacDon C Series Advantage

1



 Crimping Edge  
 Cutting Edge

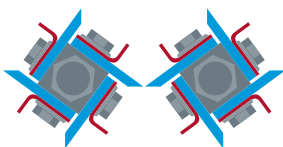

**OctiRoll™** RESIDUE MANAGEMENT SYSTEM

2



### ONE-PASS RESIDUE MANAGEMENT

With a strong focus on the agronomy of corn, MacDon C Series headers provide industry-leading residue management. In a one-pass process MacDon's OctiRoll™ Residue Management System creates well conditioned/chopped and evenly distributed residue, necessary for achieving accurate seed depth and seed placement essential for maximizing successive crop yields.

#### 1. CRIMPING:

C Series Corn Headers feature MacDon's innovative OctiRoll. Improving on the traditional snapping roll model, this unique industry-leading design incorporates 4 point-to-point knives and 4 serrated edges, that alternate to cut and crimp the stalk every 7.5 cm (3 inches). The OctiRoll's cutting/crimping action speeds up the microbial breakdown process, taking less than half the time to decompose over typical corn headers.

#### 2. CHOPPING:

Stalks are aggressively pulled through the header and residue is consistently chopped into 5 to 7.5 cm (2 to 3 inch) pieces at harvesting speeds up to 12 km/h (7.5 mph) thanks to the extra 4 serrated blades on each OctiRoll.

### OPTIMAL STALK TO CHOPPER POSITIONING

The front-mounted chopper positioned close to the underside of the rolls provides the shortest, most consistent residue size. The OctiRolls can then be run closer to the ground to better harvest downed corn while delivering the shortest stubble height possible.

You'll enjoy the direct positive drive from the specially designed high-capacity aluminum gearbox and slip clutch that powers each row unit. Chopper speed is 2800 rpm, and the chopper gearboxes can be easily disconnected row by row as needed.

### UNIQUE SNOOT DESIGN

The ribbed shape strengthens the snout structure and creates less drag allowing the material to flow over it smoothly. Featuring a unique teardrop snout design that excels at lifting downed crop, minimizing ear bounce, and following curved rows, the MacDon C Series is ready for your toughest corn harvesting challenges.

# Advantages & Features

## More C Series Features & Advantages



### STRONG, LIGHT, AND FUEL EFFICIENT

- Light yet robust frame structure and row units reduce weight.
- The reduced frame weight, high-performance OctiRolls, aluminum gearboxes and compact driveline require less power from the combine resulting in reduced fuel consumption.



### SERIOUS CUTTING PERFORMANCE & INNOVATION

- MacDon's OctiRoll Residue Management System features 4 point-to-point knives and 4 additional serrated edges on each OctiRoll. This feature creates more pinch points on the stalk per revolution of the roll, resulting in less trash intake and stalk slippage, and allows for a more thorough stalk cut, crimping, and chopping process.
- Chopper models feature aluminum stalk chopper gearboxes with large oil volumes to help prevent overheating. The optimized position of the chopping knives relative to the snapping rolls ensures excellent chopping quality even at harvesting speeds up to 12 km/h (7.5 mph).
- Knives can be reversed when the front edge wears to prolong life & reduce operational costs



### EASY MAINTENANCE

- Each front-supported OctiRoll uses two sealed double row ball bearings. The grease in the cavity forms a barrier to prevent dirt & debris from contacting the bearing seal. The greasing interval is every 250 hours of operation.



### BUILT TOUGH FOR INCREASED HARVESTING UP-TIME

- A Walterscheid radial pin safety clutch protects the compact aluminum row unit gearbox.
- The high-performance OctiRolls feature 4 hardened carbide knives bolted to each roll shaft for easy replacement.
- The gathering chain drive sprockets feature a unique low profile tooth design that protects the gathering chain should the chain meet an obstruction; this also helps to protect the row unit driveline.



### COMBINE INTERCHANGEABILITY

- MacDon C Series Headers are designed to fit most major brand combines with an easy to install completion package. This multi-brand compatibility and interchangeability mean your investment will hold its value when it's time to update your header.



### Need More Info?

Use your phone camera to scan the QR code for support documents, videos & more!

# Setup & Settings

Please refer to Operator's Manual for more information.

## Header Operating Speed:

Recommended header operating speed is 550 rpm

Combine	Backshaft Speed		Header Speed			
	Range	Rated	11 tooth	12 tooth	15 tooth	18 tooth
NH fixed drive	575	-	-	575	-	-
NH variable drive	402-575	550	-	402-575	-	-
AGCO fixed drive	617	-	673	-	-	-
AGCO variable drive	608-975	825	-	-	-	405-650
JD fixed drive	520	-	567	-	-	-
JD variable drive	520-785	688	-	-	416-628	-
Case-1000-2000 series	500	-	545	-	-	-
Case AFX variable drive	460-690	596	-	460-690	-	-
Lexion fixed drive	761	-	-	-	609	-
Lexion variable drive	508-737	688	-	-	406-590	-

## Row Unit Angle:

Preferred angle is 23° measured off snapping plates.

To set angle

- Lower front of row unit on 4"X4" block
- Measure angle on snapping plate
- Adjust combine feederhouse faceplate as required to achieve 23°

## Snouts:

Once row unit angle is set, adjust poly snouts as required.

Major adjustment with cross bolt and fine tune adjustment with eye bolt until snout just touches the ground.

## Checking Snapping (Deck) Plate Clearance:

Set the in-cab snapping plate adjusting mechanism to the minimum snapping plate gap. Check the clearance of the fixed snapping plate **(2)** relative to the movable snapping plate **(1)** for a gap of 18 mm (3/4") at the front **(dimension A)** and 24 mm (15/16") at the rear **(dimension B)**. If needed, adjust the clearance by loosening the retaining bolts **(3)**. When the adjustment is correct re-tighten the bolts.

Repeat for all remaining row units.

In-cab operation should result in the nominal gap of 27 mm (1-1/16") at the front and 32 mm (1-1/4") at the rear in the mid-range of travel.

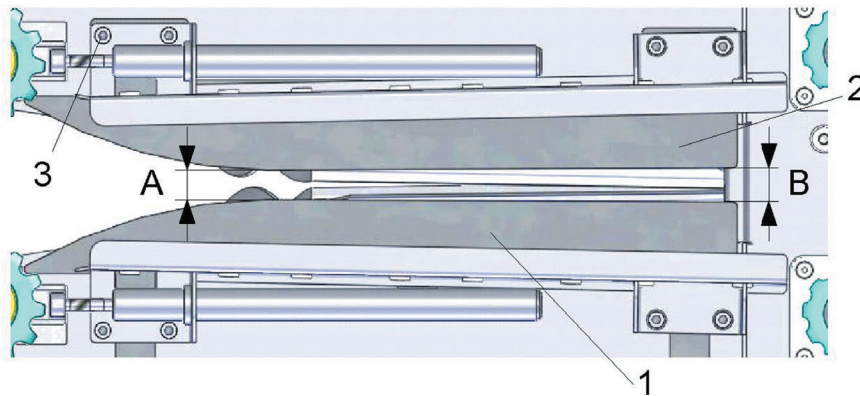

There is a tool now available to aid in setting snapping plate clearance. The tool can be ordered from your dealer: part # 324048.

When adjusting the snapping plates, occasionally the bracket that the snouts sit on can come out of alignment. There is a tool that can aid in aligning the snouts and brackets. Order part # 324144 from your dealer.

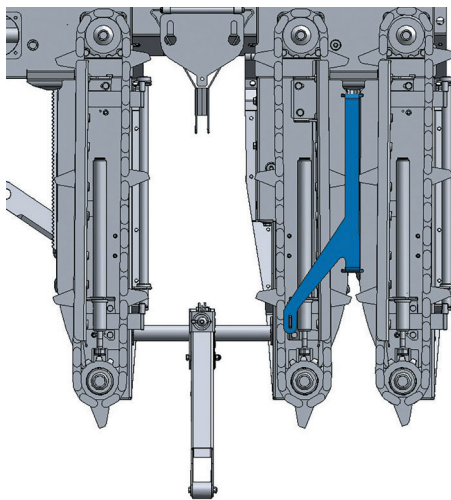

**Snapping plate tool**

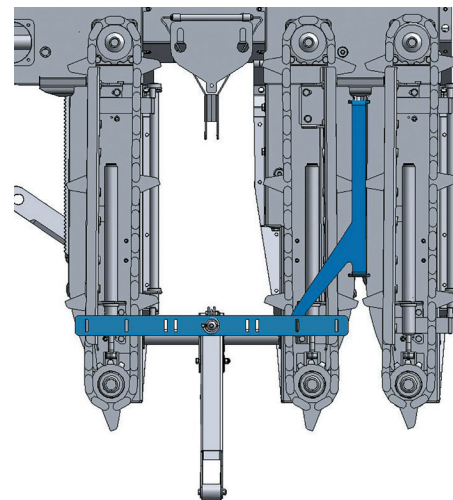

**Snout Seating Tool**

---

## Vine Knife:

Maximum clearance: 0.5 mm. Four bolts per vine knife required to adjust. Set to one knife then rotate snapping roll to ensure no interference from all knives.

## Auger Setup:

Clearance to pan: 25 – 32 mm (1" – 1.25")

Speed: Slow speed 14 tooth; High speed 16 tooth (factory)

Factory configured in the center area with reverse, full flighting.

Included options are: Fingers (for very dry, fluffy corn) or Paddles (installed over top of fingers if wrapping becomes problematic)

Double Auger Timing – flighting should be offset 180° (one side to the other)

Paddles/fingers offset 90° (the paddles should lag the flighting to strip crop from auger and push it rearward)

Folding Headers – Wing Auger Timing

- distance between flighting should be 455 - 560 mm (18" - 22") auger pitch across wing joint
- center auger flighting should lag wing flighting
- ensure the wing is engaging the center section when checking timing

This can be adjusted by removing the dog coupler on wing and rotating appropriate direction on hex shaft, then reinstalling.

**NOTE:** *The auger can come out of time if one auger stalls or if the drivelines are a few splines off when hooking up to the combine (this can be corrected by turning driveline on one side or removing auger chain and rotating auger until desired position is achieved).*

---

## Chopping Mechanisms engage / disengage:

Engage or disengage the chopper blades by turning the hex nut 180°.

There is a dimple in the surface of the hex nut for visual assistance.

Do this for each set of chopping blades.





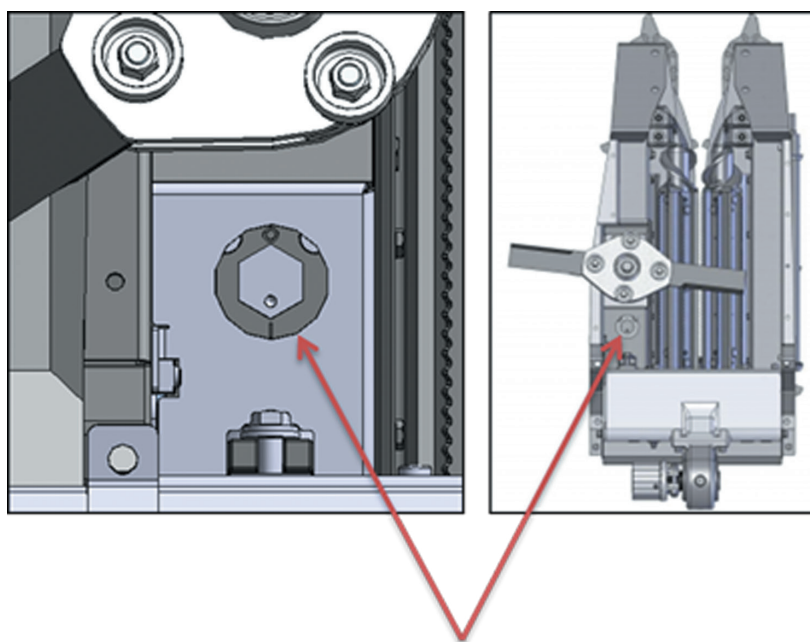







A tool is provided.

- Dimple lined up with the line is chopper disengaged
- Dimple lined up with the circle is chopper engaged





### Lubrication Table

#	type	period	qty.
1	 EP NLGI grade 2*	250[h]	look at the operator's manual
2	 EP-00 grease	250[h]	5,5[pounds], 2,5 [kg]
3	 EP NLGI grade 2*	250[h]	look at the operator's manual
4	  EP NLGI grade 2* alt.: Gearbox Oil	250[h]	look at the operator's manual
5	 EP NLGI grade 2*	50[h]	look at the operator's manual
6	 EP NLGI grade 2*	250[h]	look at the operator's manual
7	 EP NLGI grade 2*	250[h]	look at the operator's manual
8	 Gearbox oil	50[h]	look at the operator's manual
9	 Gearbox oil	10[h]	look at the operator's manual
10	 SAE 80W-140**	50[h]	10,15[fl.oz.], 0,3 [l]
11	 SAE 80W-140**	250[h]	30,45[fl.oz.], 0,9 [l]

\*high temperature, 1% max molybdenum disulphide, lithium base  
\*\* SAE 85W-140 can be used as an alternative

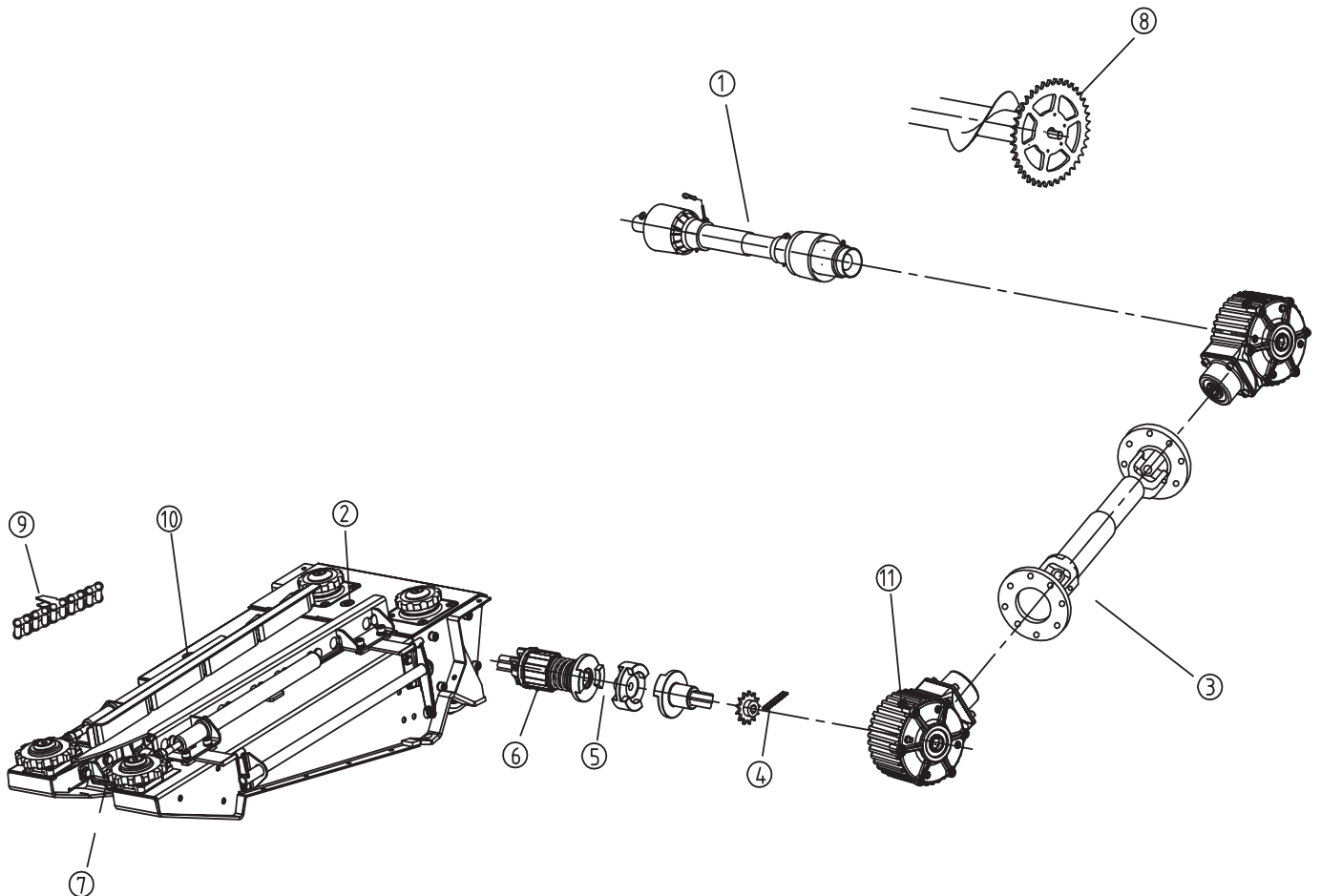

---

## Maintenance / Lubrication:

Use high temperature extreme pressure (EP) performance grease with 1% max molybdenum disulfide (NLGI Grade 2) lithium base unless otherwise specified.

## Gathering Chains:

Lubricate every 10 hours with a synthetic or vegetable grease or oil

The gathering chain tension is maintained automatically by an enclosed spring on the front idler sprocket.

No adjustment is required.

A specialized tool is provided for service.

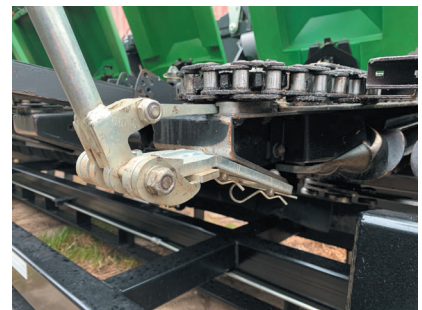
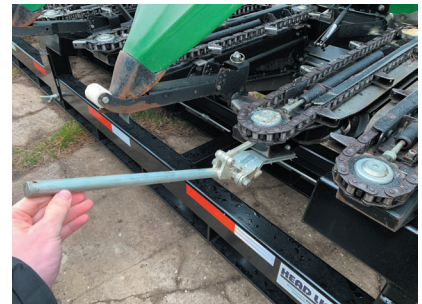

---

## Gathering Chain Timing:

The gathering chain lugs may come out of time if gathering chains encounter hard objects such as rocks or stumps. Use tool to loosen gathering chain tension and rotate chain to desired timing orientation.

Fully Staggered  
Least aggressive  
Good conveyance

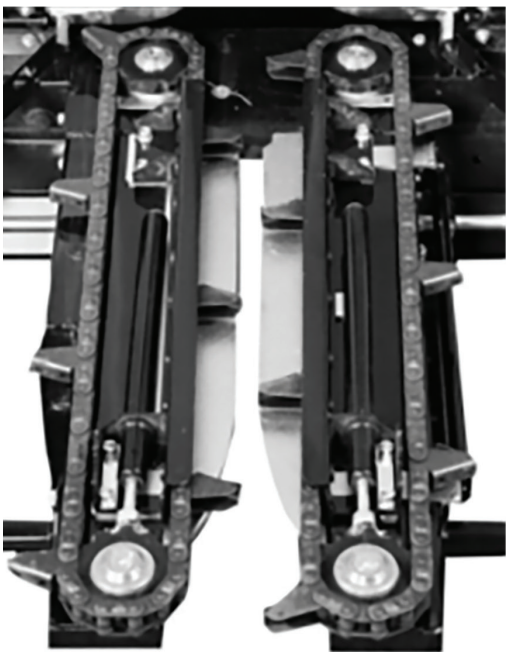

Fully In-Phase (lugs lined up)  
Most aggressive  
Brings in most trash/debris  
Good for lodged corn



One lug staggered  
Good compromise  
Factory setting



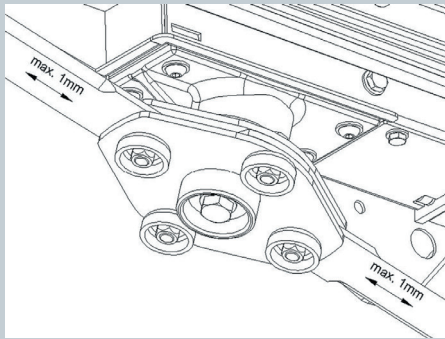

### Chopper knives:

Check knife condition daily. Check knife hardware daily.

Knives can be reversed when worn. Knives must be changed in pairs to maintain proper balance. When knife replacement is necessary, replace bushings and bolts.

***! Never operate with damaged knives!***



### Auger drive chain(s):

Check tension daily.

Clean debris every 50 hrs.

Deflection of 13-19 mm (1/2 - 3/4 inch) at slack side (mid-point of short span. Note drive rotation).

Lubricate drive chain every 50 hrs.

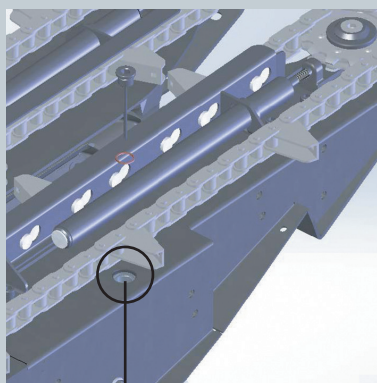

Lubricant fill plug / dipstick

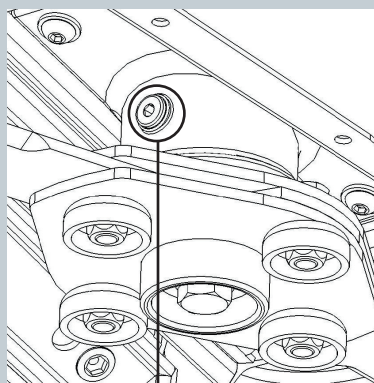

Lubricant drain

### Stalk chopper gearboxes (If equipped)

SAE 80W-140 (0.3 L) Check every 50hrs

85W-140 can be used as an alternative per the lubrication table

Remove dipstick, clean, replace but do not screw in, wait, then remove and inspect oil level

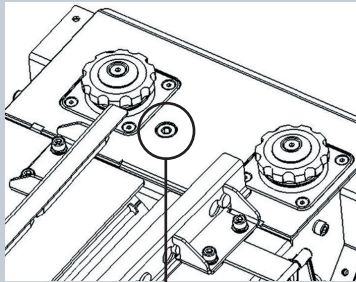

Lubricant fill plug / dipstick

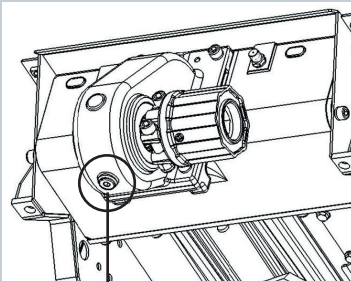

Lubricant drain plug

### Snapping unit (Row unit) gearboxes:

EP – 00 grease (2.5 L) Check every 250 hrs  
(annually)

Check dipstick in field (operating) position

Remove dipstick, clean, replace but do not  
screw in, wait, then remove and inspect oil level

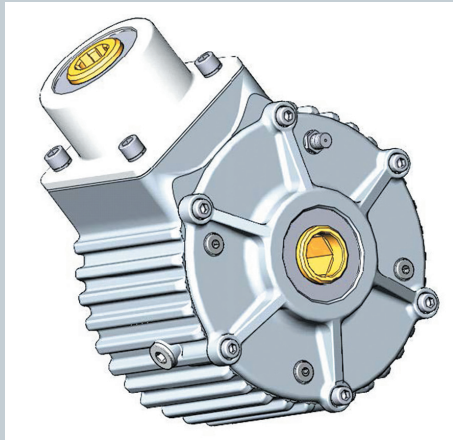

### Input gearboxes (header drive):

Break In Service: Change oil at 50 hrs.

SAE 80W-140 (0.9 L) Check every 250 hrs (annually)

85W-140 can be used as an alternative per the lubrication table

Check with header in field (operating) position.

*For more information on maintenance points listed on the following pages, please see your Operators Manual.*

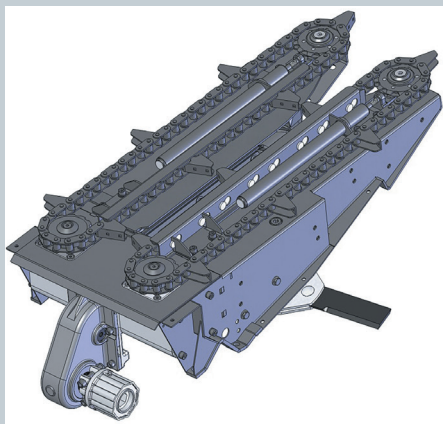

### Header drive shafts:

Grease every 250 hrs (annually)

**Chain couplings**, grease every 250 hrs (annually) using oil per the  
lubrication table, gearbox oil can be used as an alternative

**Row Unit Slip Clutches** grease every 250 hrs (annually)

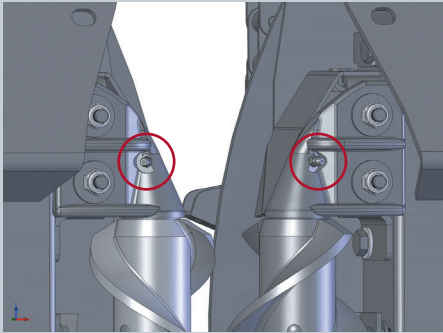

### Snapping rolls:

Four point to point replaceable hardened carbide knives.

Four replaceable serrated knives

One grease zerk on each roll filling a cavity in front of two replaceable sealed double row bearings at the front of each roll

Grease every 250 hrs (annually) until grease extrudes from the cavity

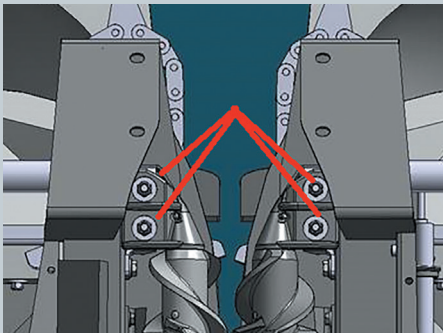

### Snapping rolls knife spacing adjustments:

The recommended gap between knives is 1 mm for all headers

As the knives wear, loosen 4 bolts to slide end of knife rolls closer together to achieve spacing as desired. Retighten hardware

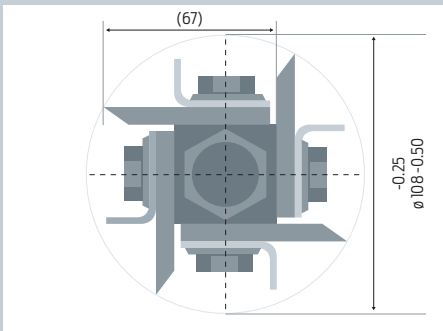

When replacing knives, set to dimensions listed to ensure knives are set square to rolls

After installing new knives, rotate rolls by hand to ensure there is no contact

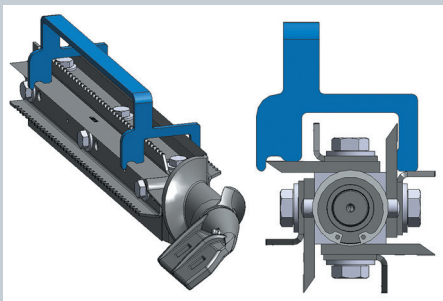

To aid in correct installation of new knives onto snapping rolls, tool part # 324124 can be ordered

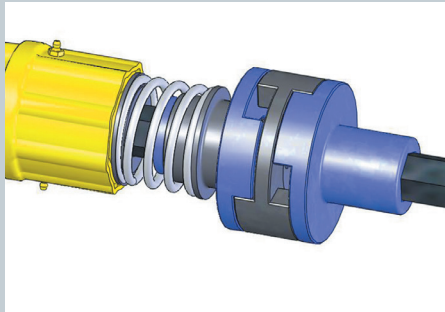

### Folding Corn Header:

Snapping unit connecting clutch jaws, grease every 50 hrs



Auger connecting clutches, grease the surfaces of the jaws every 50 hrs

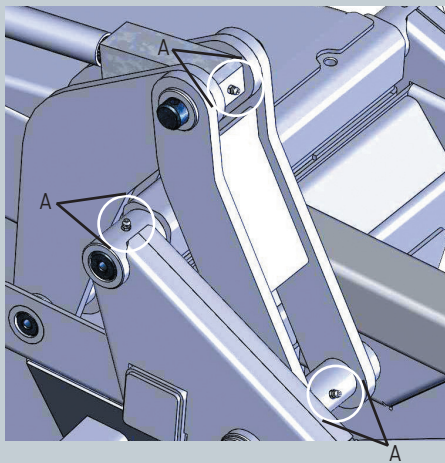

Frame hinge points, 3 grease locations each side (A), grease every 250 hrs (seasonally)

# Options

---



## Rotary End Dividers

Aid in down crop conditions.

Speed is adjustable from cab.



## Tall End Dividers

Assists in dividing rows and saving ears in tall standing corn.



## AHHC

Headsight compatible, will work with most major brand late model combines.





## Upper Ear Savers

To prevent ears from bouncing over the front of the header.



## Stubble Stompers

Helps prevent combine tire degradation, particularly in chopped or short corn stubble conditions.

Spring loaded, adjustable

### STUBBLE STOMPER MOUNTING LOCATIONS (ON ROW #)

	50.8 cm (20")	55.9 cm (22")	76.2 cm (30")	96.5 cm (38")
<b>6 Row</b>	-	-	1, 2, 5, 6	-
<b>8 Row</b>	-	1, 2, 7, 8	1, 2, 3, 6, 7, 8	1, 2, 3, 6, 7, 8
<b>8 Row Folding</b>	-	-	2, 3, 6, 7	-
<b>12 Row</b>	2, 3, 4, 9, 10, 11	2, 3, 4, 9, 10, 11	3, 4, 5, 8, 9, 10	3, 4, 5, 8, 9, 10
<b>12 Row Folding</b>	-	-	3, 4, 5, 8, 9, 10	-
<b>16 Row</b>	-	-	5, 6, 7, 10, 11, 12	-
<b>18 Row</b>	5, 6, 7, 12, 13, 14	5, 6, 7, 12, 13, 14	-	-

---

## In-field adjustments for challenging conditions:

- Changing auger speed
- Changing auger configuration: full flighting, fingers, paddles, or no flighting
- Adjusting deck plates
- Gathering chain phasing

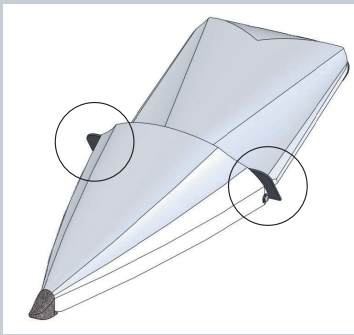

### Ear Savers

Rubber flaps which help prevent ears from being thrown out the front of the header

In severely laid down or lodged crop, it may be necessary to remove one or both of the rubber ear savers to improve feeding to the row units.

# Notes

---

---

---

---

---

---

---

---

---

---

---

---

---

---

---

---

---

---

---

---

---

---

---

---

---

---



### Need More Info?

Use your phone camera to scan the QR code for support documents, videos & more!

**MacDon**® *The Harvesting Specialists.*

*MacDon.com*