

HOOP STYLE COMFY CALF SUITES

INSTALLATION INSTRUCTIONS



Installation or product problems? Call 1-800-260-5314

COMFY CALF SUITES - HOOP STYLE



Congratulations on the purchase of Comfy Calf Suites! These instructions will guide you through the installation process and identify parts and accessories so please read through them and save them for future reference.

ILLUS.	DESCRIPTION	PART #
1	PLASTIC CAP 1.5" X 72" (OR 96" LG)	2013130-72 / 2013130-96
2	PLASTIC PLANK 10" X 72" LG (OR 96" LG)	2013030-72 / 2013030-96
3	BOTTOM PLUG / PLANK 20' LG (cut to size)	2013220
4	GALVANIZED 24" FRONT (2 HOLE) (36" OC PEN)	1241136
	GALVANIZED 30" FRONT (2 HOLE) (42" OC PEN)	1241142
	GALVANIZED 36" FRONT (2 HOLE) (48" OC PEN)	1241148
5	GALVANIZED 2-WAY CALF LATCH	1240100
6	GALVANIZED DBL PAIL HOLDER ONLY	1241210A
7	PLASTIC CALF PAIL (WHITE)	1235033
8	STAINLESS STEEL CALF CHANNEL (20 GA) 41" HIGH	1240041
	51" HIGH	1240051
9	HDW PKG (HOOP SUITE) INCL U-BOLT, EYE PIN & HANDLE	1270100HDW
10	STAINLESS STEEL 24" MOUNT CHANNEL / CALF SUITE	1240226
11	HINGE STRAP / CALF SUITE - 41" LG	1275241
	51" LG	1275251
12	33" OD CALF ARCH (36" O.C. PEN)	1290136
	(42" O.C. PEN)	1290142
	(48" O.C. PEN)	1290148
13	FORMED CLAMP (1" PIPE) (FOR ROW END ONLY)	2060260
14	GALVANIZED 32 3/4" RETAINER CHANNEL (36" OC PEN)	1240264-36
	GALVANIZED 38 3/4" RETAINER CHANNEL (42" OC PEN)	1240264-42
	GALVANIZED 44 3/4" RETAINER CHANNEL (48" OC PEN)	1240264-48

ILLUSTRATION 1

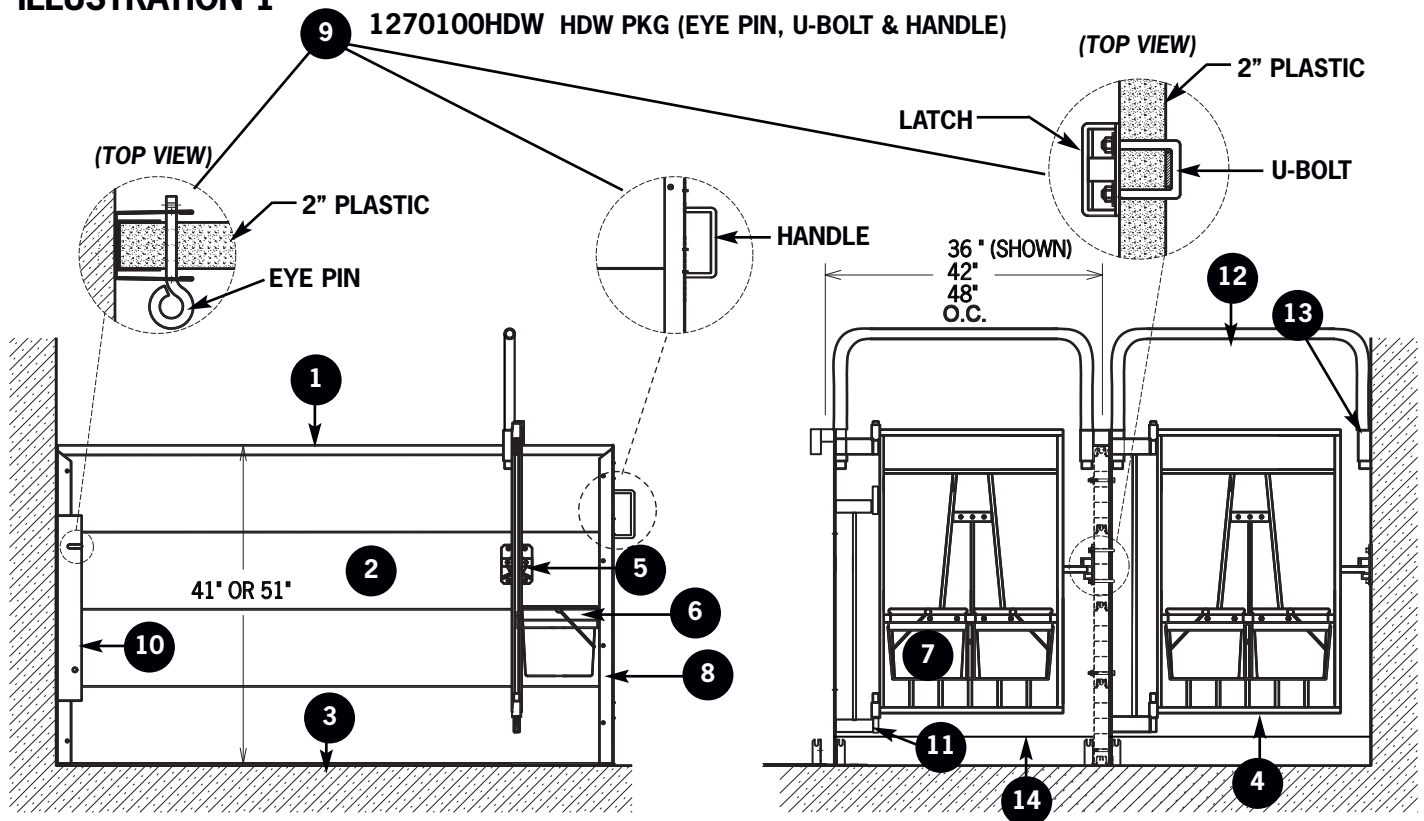

INSTALLATION:

Step #1: Install handle to front channel (2 flange nuts on outside and 2 nylon locks on inside of channel). ***TIGHTEN***. Snap planks together for dividers.

! **TIP: Slide hoop strap onto divide before putting channels on planks.**

Install front and back channels, then snap on top cap. Drill through plastic with a 1/4" bit, then fasten channels with 1/4" x 2 1/2" hex bolts.

Step #2: Install hoop strap to divider panel approximately 10" from the front with 3/8" x 3" hex bolts and 2" square washers and lock nut which are to be installed on the plank side. Fasten the 24" SS channels to the back wall at **EXACTLY** 48"OC, 42"OC or 36"OC to match your front gates.

! **TIP: When mounting hoop straps, note which way your gate will swing out for animal flow.**

Note: With our 2-way latch, you can always open gate into the pen.

Step #3: Slide divider into the back 24" channel and drill 1/2" hole through divider, then attach divider to 24" channel with removable eye pin.

Step #4: Install front gate and block post up so it is level, locate latch and mark hole locations. Drill 4 through holes to mount latch with 2 square U-bolts (around hoop strap and through holes in divider plank).

! **TIP: Add 2 more 9/16" holes on latch side only to countersink the nuts of the latch.**

Step #5: Install pail holder with 2 washers per bolt between front and pail holder.

Step #6: Install **OPTIONAL** accessories (shown on back page).

VENTED BACK WALL INSTALLATION:

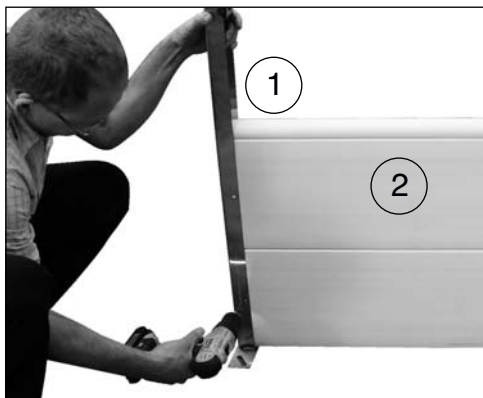

Step #1: Lag one channel post where you are starting your back wall.

Step #2: Snap together two back wall planks. Snap top cap on the planks.



Step #3: Slide the planks into the channel post

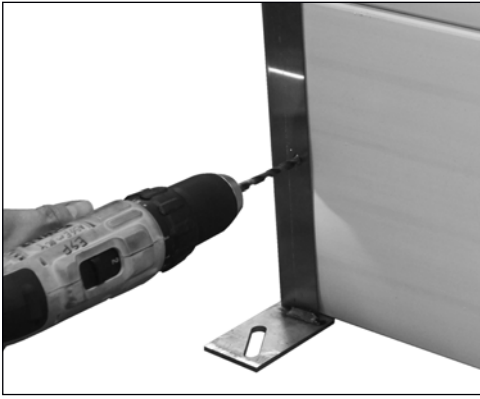

Step #4: Drill into plastic planks with 1/4" bit. (Make sure to start the hole coming from the front and the back. Don't try to go all the way through. You may not line the drill up with the hole on the backside.)

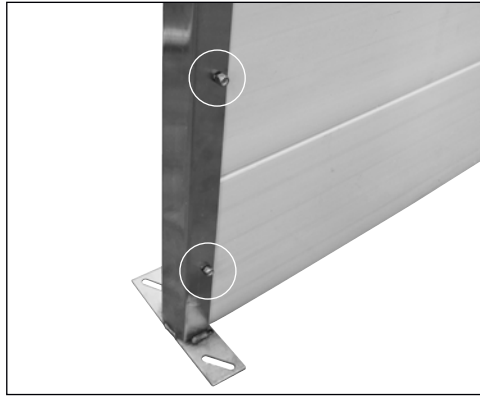

Step #5: Fasten 1/4" x 2 - 2 1/2" hex bolt and tighten.

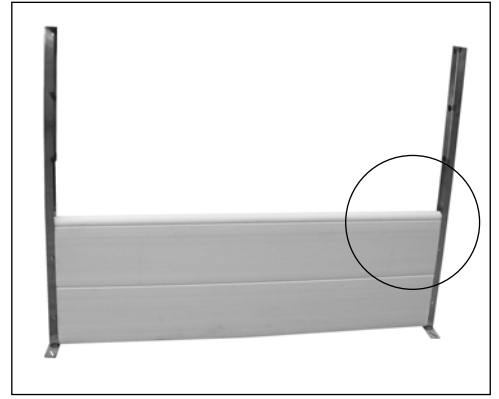

Step #6: Slide the other channel post on to the other end of the plank. (Do not fasten to post yet.)

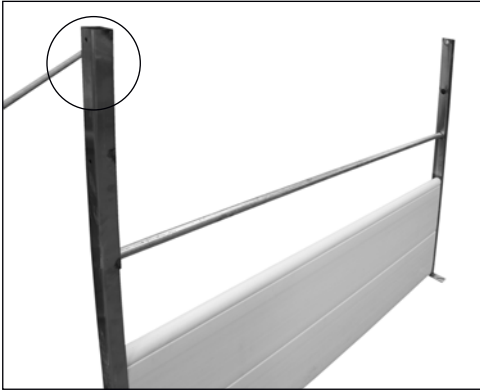

Step #7: Slide the rails in the holes at the tip of the posts.



Step #8: Repeat step #4 and #5 and drill holes and fasten with bolts.

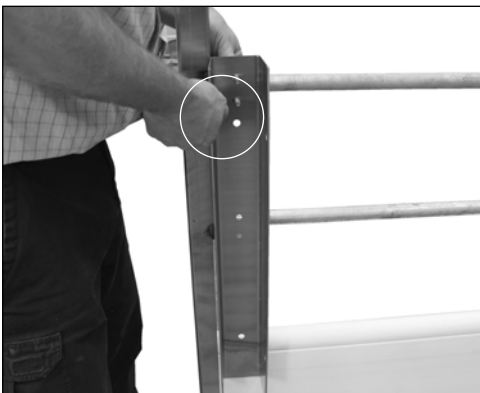

Step #9: Attach receiving channel with U-Bolts. (The channel should be attached to the bottom rails and on the inside of the calf suite)

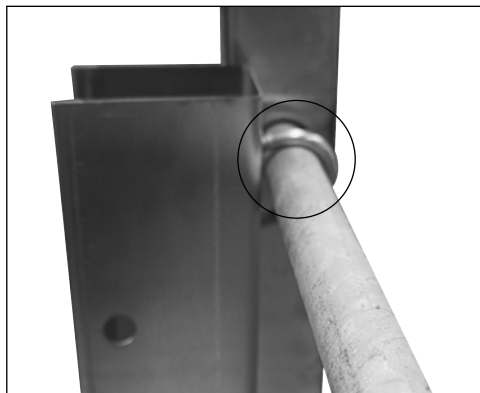

FINISHED VENTED BACK WALL

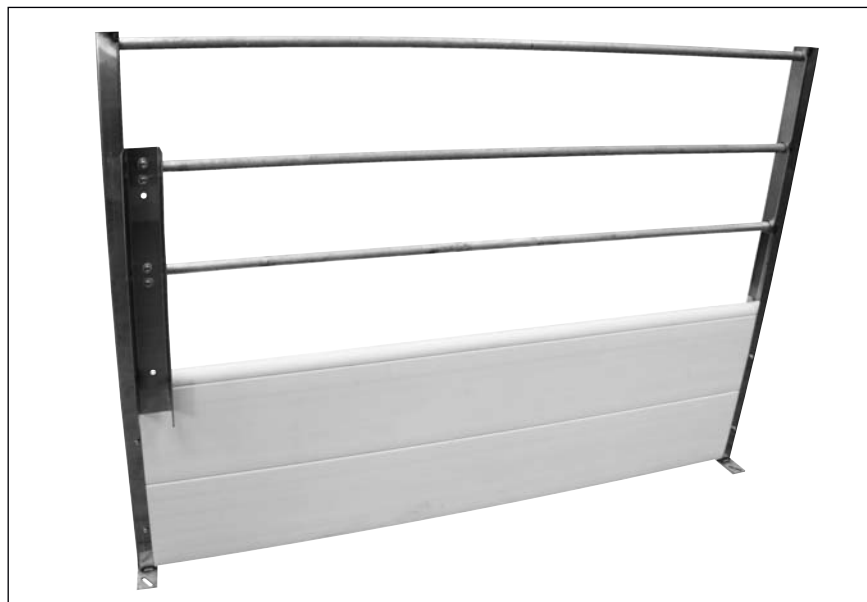

COMFY CALF SUITES - HOOP STYLE PARTS:

1241120

CALF HEAD HOLE REDUCER

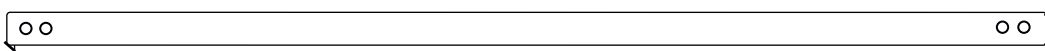

1240041

41" SS CHANNEL

1240051

51" SS CHANNEL

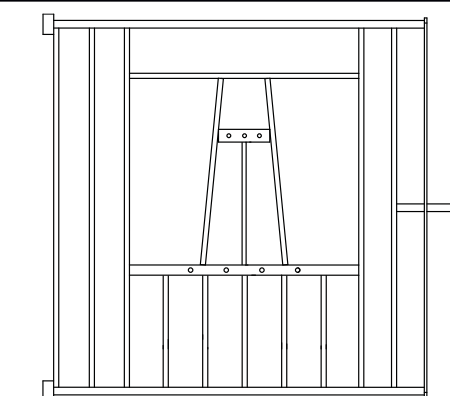

1241136 36" OC CALF FRONT (24" LG)

1241142 42" OC CALF FRONT (30" LG)

1241148 48" OC CALF FRONT (36" LG)

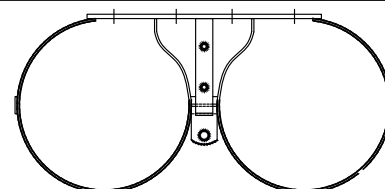

1241210A PAIL HOLDER ONLY

1270100HDW
HDW PKG/HOOP SUITE INCL HANDLE

PART NUMBER	DESCRIPTION	QTY
124025A	HANDLE ONLY 5" I.D X 2.125" LG	1
1240221	ULTRASEAL EYEBOLT 3 3/4" LG	1
1270260	SQUARE U-BOLT US 1.75" ID X 3" LG 3/8"	2
HP4	HAIR PIN (HP4)	1
BOL3/8 - 3H	+3/8 - 16 X 3 HEXBOLT US	2
BOL3/8 - 11/4H	+3/8 - 16 X 1 1/4 HEXBOLT US	2
NUT3/8FL	3/8" - 16 FLANGE NUT ULTRASEAL	2
NUT3/8LN	3/8 - 16 N.I. LOCK NUT, US	11
WAS3/8	+3/8" FLAT WASHER	7
BOL1/4 - 21/2HSS	1/4 - 20 X 2 - 1/2 SS HEX BOLT	6
NUT1/4LSS	1/4 - 20 N.I. LOCK NUT SS 304	7
1270101	2" X 2" GALV WASHER	2

1275241

41" HINGE STRAP/
HOOP SUITE

1275251

51" HINGE STRAP/
HOOP SUITE

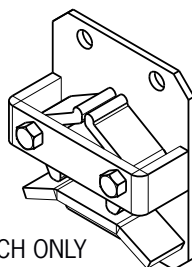
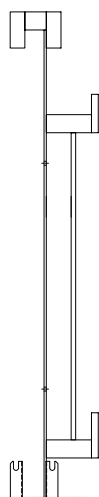

1240100

GALV 2-WAY LATCH ONLY

PART NUMBER	DESCRIPTION
2013030-72	10" HIGH PLANK X 72" LG
2013030-96	10" HIGH PLANK X 96" LG
2013130-72	TOP CAP X 72" LG
2013130-96	TOP CAP X 96" LG
CALFCARD-50	PKG OF 50 CALF SUITE RECORD CARDS
1235033	PLASTIC CALF PAIL (WHITE)

1290136

33" OD CALF ARCH (36" OC)

1290142

38" OD CALF ARCH (42" OC)

1290148

45" OD CALF ARCH (48" OC)

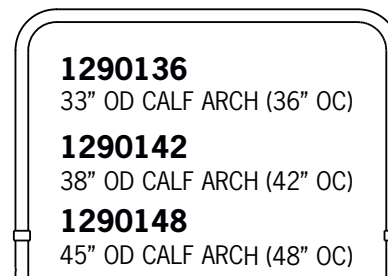

OPTIONAL ACCESSORIES

ILLUSTRATION 2

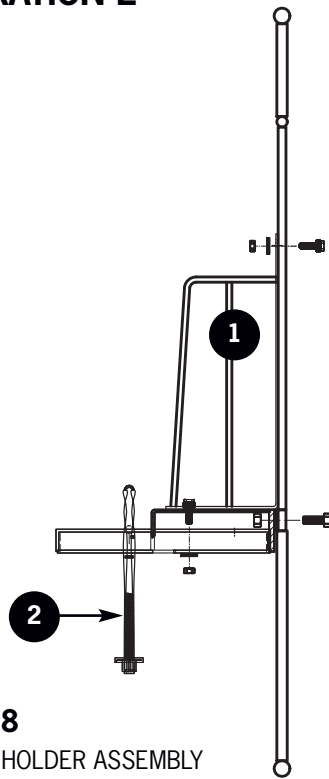

1241148

CALF PAIL HOLDER ASSEMBLY

ILLUS.	DESCRIPTION	PART #
1	1 PC STAINLESS STEEL PAIL DIVIDER + HDW	1241280SS-ND
2	CALF PAIL HOLD DOWN ASSEMBLY	1241011

ILLUSTRATION 3

ILLUS.	DESCRIPTION	PART #	QTY
1	SW CALF FRONT	1241148	1
2	1 PC STAINLESS STEEL PAIL DIVIDER + HDW	1241280SS-ND	1
3	GALV. DBL PAIL HOLDER ONLY	1240210A	1
4	CALF PAIL HOLD DOWN ASSEMBLY	1241011	1
5	CALF HOLE REDUCER	1241120	1

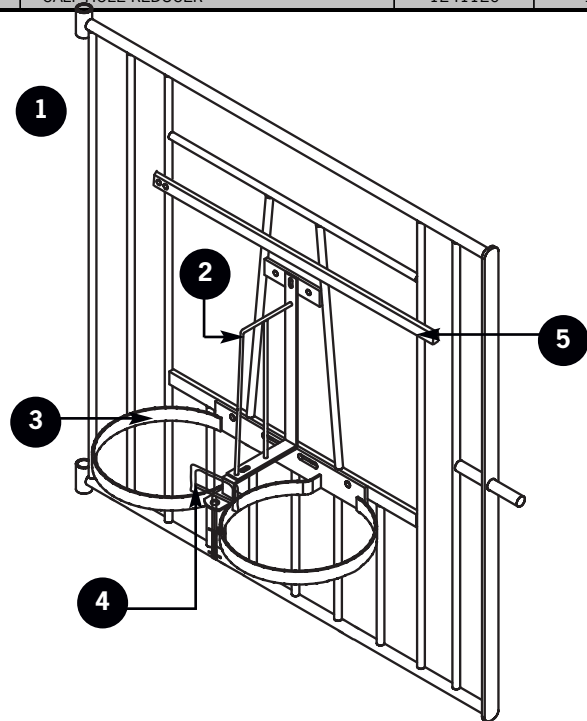

ONE PIECE STAINLESS PAIL DIVIDER

(1241280SS-ND) (Item #1 in above diagram)

Step #1: Insert bolts through holes in pail holder.

Step #2: Fasten nut and washer.

SS CALF PAIL HOLD DOWN (NO ANGLE) (1241011) (Item #4 in above diagram)

Step #1: Remove nut washer and spring.

Step #2: Install hold down through hole in pail holder.

Step #3: Install spring, washer and nut.

REMEMBER TO PUT TWO WASHER SPACERS BETWEEN PAIL HOLDER & FRONT

1240235-3
BOLT ON BOTTLE HOLDER

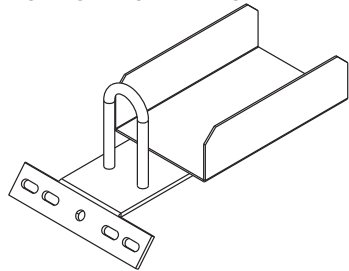

1241235
QUICK INSTALL BOTTLE HOLDER

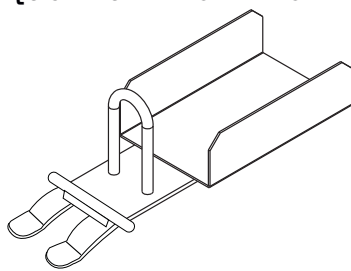

1235030
HAY FEEDER

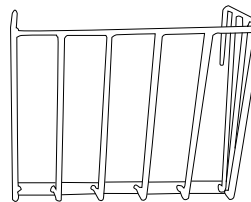

1240245PK
MANUAL LOCK

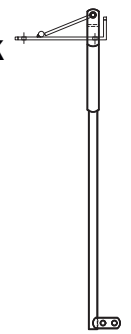

Please visit www.comfyalfsuities.com for more information on our Comfy Calf Suites and www.canarm.com for detailed information on all our Dairy and Ventilation products.

CANARM LTD. - Corporate Office
2157 Parkedale Ave., PO Box 367 Brockville, ON
Canada K6V 5V6
Tel: (613) 342-5424 Fax: 1-800-263-4598
E-Mail: agsales@canarm.ca

www.canarm.com

CANARM LTD. - USA Warehouse
808 Commerce Park Drive
Ogdensburg, New York, USA 13669
Tel: 1-800-267-4427 Fax: 1-800-263-4598

www.comfyalfsuities.com

Arthur Manufacturing Facility
#7686 Concession 16, RR 4 Arthur, ON
Canada N0G 1A0
Tel: (519) 848-3910 Fax: (519) 848-3948
E-Mail: agsales@canarm.ca