

Farm King

OPERATOR AND PARTS MANUAL

CX  **SERIES**

CONVENTIONAL AUGER MOVER

Models 841, 851, 861, 1041, 1051, 1061

TABLE OF CONTENTS

Manufacturer's Statement: For technical reasons, Farm King reserves the right to modify machinery design and specifications provided herein without any preliminary notice. Information provided herein is of descriptive nature. Performance quality may depend on soil fertility, applied agricultural techniques, weather conditions, and other factors.

INTRODUCTION.....	5
SAFETY.....	9
ASSEMBLY.....	17
OPERATION.....	35
MAINTENANCE.....	45
PARTS IDENTIFICATION.....	55
SPECIFICATIONS.....	75
WARRANTY.....	81

Farm King



WARRANTY REGISTRATION FORM

This form must be filled out by the dealer and signed by both the dealer and the customer at the time of delivery.

Customer Name:	
Customer Address:	
City:	Prov / State:
Postal / Zip Code:	Phone:

Dealer Name:	
Dealer Address:	
City:	Prov / State:
Postal / Zip Code:	Phone:

Auger Model:	Serial Number:	Delivery Date:
--------------	----------------	----------------

I have thoroughly instructed the buyer on the above described equipment which review included the Operator and Parts Manual content, equipment care, adjustments, safe operation and applicable warranty policy.

Dealer Inspection Report

- Bearings Turn Freely
- Belt Tension Checked
- Auger Tube Is Straight
- Flighting Turns Freely
- Gear Box Oil Level Checked
- All Fasteners Are Tight
- Machine Is Lubricated
- Check Tire Pressure

Safety

- All Lights And Reflectors Installed
- All Lights And Reflectors Cleaned And Working
- Safety Chain On Hitch
- All Decals Installed
- Guards And Shields Installed And Secure
- Review Operating And Safety Instructions
- Check For Hydraulic Leaks

Date:	Dealer Rep. Signature:
-------	------------------------

The above equipment and Operator And Parts Manual have been received by me and I have been thoroughly instructed as to care, adjustments, safe operation and applicable warranty policy.

Date:	Customer / Owner Signature:
-------	-----------------------------

Remove this Warranty Registration Form from the Operator And Parts Manual. Make two copies of the form. Send original Warranty Registration Form to Farm King. Give one copy to the customer and the dealer will keep one copy.

Farm King



INTRODUCTION

This Operator And Parts Manual was written to give the owner / operator instructions on the safe operation, maintenance and part identification of the Farm King equipment. READ AND UNDERSTAND THIS OPERATOR AND PARTS MANUAL BEFORE OPERATING YOUR FARM KING EQUIPMENT. If you have any questions, see your Farm King dealer. This manual may illustrate options and accessories not installed on your Farm King equipment.

OWNER'S INFORMATION.....	7
Serial Number Location.....	7
Manual Storage.....	7
EQUIPMENT IDENTIFICATION.....	8
Component Location.....	8

Farm King



OWNER'S INFORMATION

Thank you for your decision to purchase a Farm King CX2 Conventional Auger Mover. To ensure maximum performance of your equipment, it is mandatory that you thoroughly study the Operator And Parts Manual and follow the recommendations. Proper operation and maintenance are essential to maximize equipment life and prevent personal injury.

Operate and maintain this equipment in a safe manner and in accordance with all applicable local, state, and federal codes, regulations and / or laws. Follow all on-product labeling and instructions.

Make sure that all personnel have read this Operator And Parts Manual and thoroughly understand safe and correct operating, installation and maintenance procedures.

Farm King is continually working to improve its products. Farm King reserves the right to make any improvements or changes as deemed practical and possible without incurring any responsibility or obligation to make any changes or additions to equipment sold previously.

Although great care has been taken to ensure the accuracy of this publication, Farm King makes no warranty or guarantee of any kind, written or expressed, implied or otherwise with regard to the information contained within this manual. Farm King assumes no responsibility for any errors that may appear in this manual and shall not be liable under any circumstances for incidental, consequential or punitive damages in connection with, or arising from the use of this manual.

Keep this manual available for frequent reference. All new operators or owners must review the manual before using the equipment and annually thereafter. Contact your Farm King Dealer if you need assistance, information, or additional copies of the manual.

Visit our website at www.farm-king.com for a complete list of dealers in your area.

The directions left, right, front and rear, as mentioned throughout this manual, are as viewed by the operator sitting in the tractor seat while towing the implement.

Serial Number Location

Enter the model and serial number in the space provided for easy reference.

Figure 1

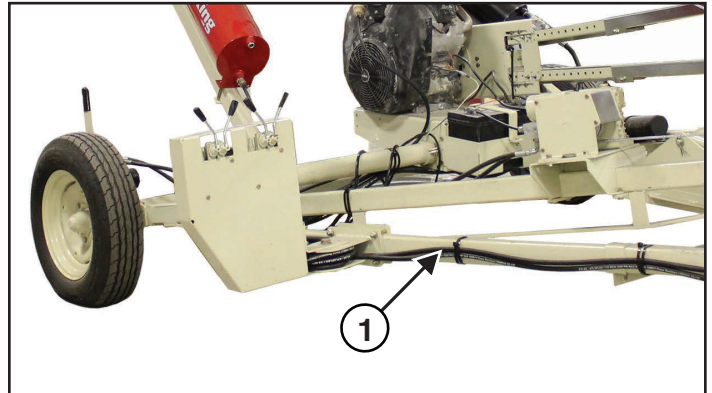

Model Number:
Serial Number:

The serial number plate (Item 1) [Figure 1] is located on the RH lift frame.

Always use your serial number when requesting information or when ordering parts.

Manual Storage

Figure 2

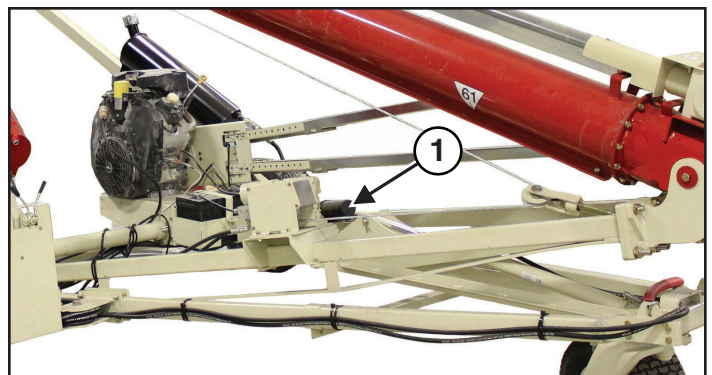

The operator and parts manual and other documents can be stored in the canister (Item 1) [Figure 2] located on the LH lift frame.

EQUIPMENT IDENTIFICATION

Component Location

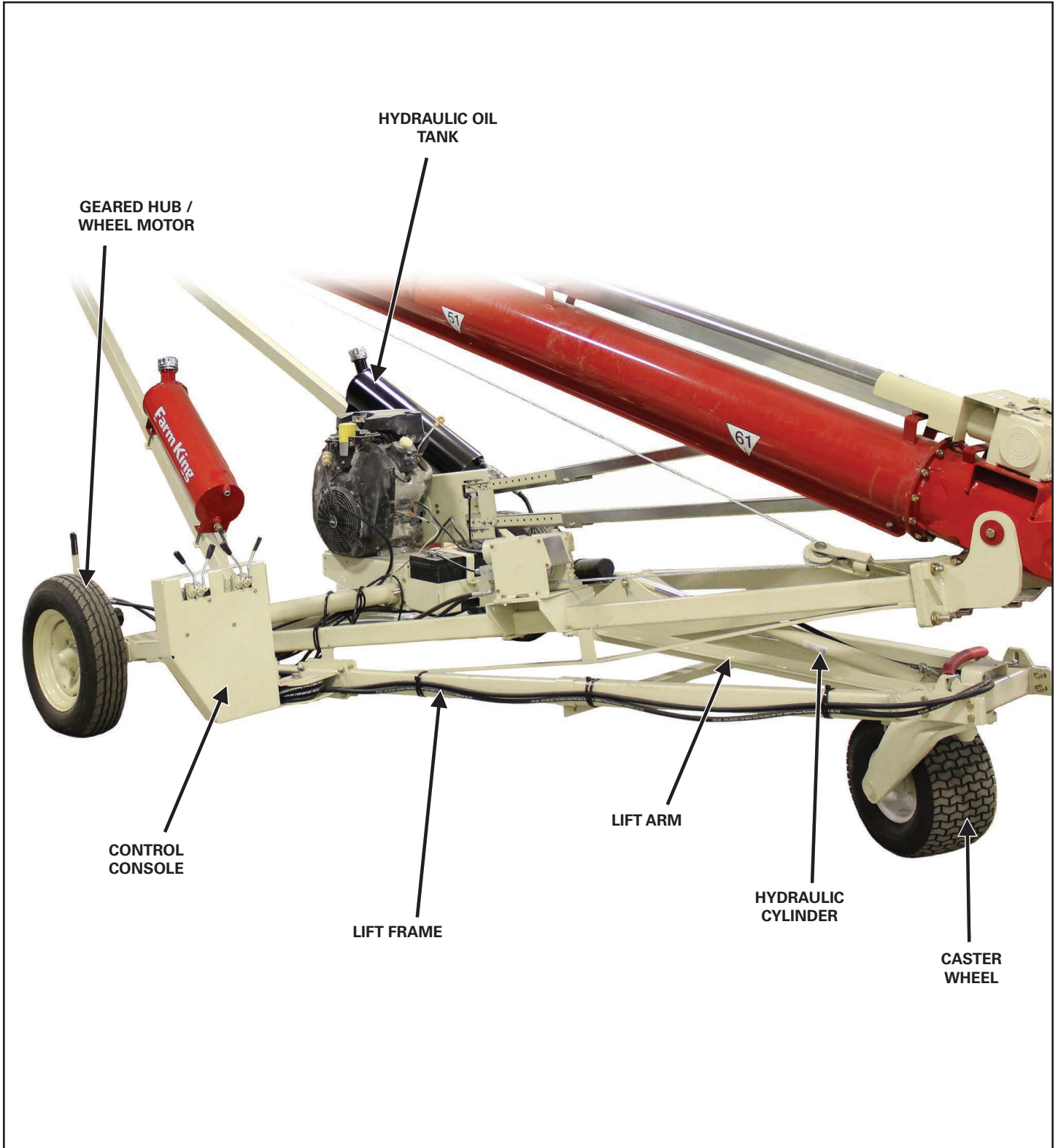

SAFETY

SAFETY INSTRUCTIONS.....	11
Safe Operation is The Operator's Responsibility.....	11
Safe Operation Needs A Qualified Operator.....	11
Use Safety Rules.....	12
Safety Rules For Power Take-Off (PTO) Driven Equipment.....	12
Machine Requirements And Capabilities.....	13
Transport Safety.....	13
FIRE PREVENTION.....	14
Maintenance.....	14
Operation.....	14
Fire Extinguishers.....	14
Electrical.....	14
Hydraulic System.....	14
Fueling.....	14
Welding And Grinding.....	14
GAS ENGINE SAFETY.....	15
OPERATING SAFETY ZONE.....	16
Safety Zone Identification.....	16

Farm King





SAFETY INSTRUCTIONS

Safe Operation is The Operator's Responsibility

	Safety Alert Symbol
<p>This symbol with a warning statement means: "Warning, be alert! Your safety is involved!" Carefully read the message that follows.</p>	

	CAUTION
<p>The signal word CAUTION on the machine and in the manuals indicates a potentially hazardous situation which, if not avoided, may result in minor or moderate injury. It may also be used to alert against unsafe practices.</p>	

	DANGER
<p>The signal word DANGER on the machine and in the manuals indicates a hazardous situation which, if not avoided, will result in death or serious injury.</p>	

	WARNING
<p>The signal word WARNING on the machine and in the manuals indicates a potentially hazardous situation which, if not avoided, could result in death or serious injury.</p>	

	IMPORTANT
<p>This notice identifies procedures which must be followed to avoid damage to the machine.</p>	

Safe Operation Needs A Qualified Operator

	WARNING
<p>Operators must have instructions before operating the machine. Untrained operators can cause injury or death.</p>	

For an operator to be qualified, he or she must not use drugs or alcohol which impair alertness or coordination while working. An operator who is taking prescription drugs must get medical advice to determine if he or she can safely operate a machine and the equipment.

Understand the written instructions, rules and regulations:

- The written instructions from Farm King include the Warranty Registration, Dealer Inspection Report, Operator And Parts Manual and machine signs (decals).
- Check the rules and regulations at your location. The rules may include an employer's work safety requirements. Regulations may apply to local driving requirements or use of a Slow Moving Vehicle (SMV) emblem. Regulations may identify a hazard such as a utility line.

Have Training with Actual Operation:

- Operator training must consist of a demonstration and verbal instruction. This training is given by the machine owner prior to operation.
- The new operator must start in an area without bystanders and use all the controls until he or she can operate the machine safely under all conditions of the work area.

Know the Work Conditions:

- Clear working area of all bystanders, especially small children and all obstacles that might be hooked or snagged, causing injury or damage.
- Know the location of any overhead or underground power lines. Call local utilities and have all underground power lines marked prior to operation.
- Wear tight fitting clothing. Always wear safety glasses when doing maintenance or service.

Use Safety Rules

- Read and follow instructions in this manual and the tractor's Operators Manual before operating.
- Under no circumstances should young children be allowed to work with this equipment.
- This equipment is dangerous to children and persons unfamiliar with its operation.
- If the elderly are assisting with work, their physical limitations need to be recognized and accommodated.
- Stay clear of overhead power lines when raising or lowering the auger. Electrocuting can occur without direct contact.
- Check for overhead and / or underground lines before operating equipment (if applicable).
- In addition to the design and configuration of equipment, hazard control and accident prevention are dependent upon the awareness, concern, prudence and proper training of personnel involved in the operation, transport, maintenance and storage of equipment.
- Check that the equipment is securely fastened to the tractor / towing vehicle.
- Make sure all the machine controls are in the NEUTRAL position before starting the machine.
- Operate the equipment only from the operator's position.
- Operate the equipment according to the Operator And Parts Manual.
- When learning to operate the equipment, do it at a slow rate in an area clear of bystanders, especially small children.
- DO NOT permit personnel to be in the work area when operating the equipment.
- The equipment must be used ONLY on approved tractors / transport vehicles.
- DO NOT modify the equipment in any way.
- Unauthorized modification may impair the function and / or safety and could affect the life of the equipment.
- DO NOT make any adjustments or repairs on the equipment while the machine is running.
- Keep shields and guards in place. Replace if damaged.

Safety Rules For Power Take-Off (PTO) Driven Equipment

- Keep PTO shields and all guards in place. Replace damaged or missing shields and guards before operating.
- Follow warnings and instructions on machine signs (decals). Replace damaged or missing decals.
- Do not wear loose or bulky clothing around the PTO or other moving parts.
- Keep bystanders away from PTO driven equipment, and never allow children near machines.
- Read and understand the manuals for the PTO driven equipment and be aware of safe operating procedures and hazards that may not be readily apparent.
- Always walk around equipment to avoid coming near a turning PTO drive line. Stepping over, leaning across or crawling under a turning PTO drive line can cause entanglement.
- Position the machine and equipment hitch correctly to prevent drive line stress and separation.
- Use caution when turning. Turning too sharp can cause drive line damage.
- Use caution when raising PTO driven attachment.
- Excessive drive line angle can cause drive line damage. Use stops if needed.

Machine Requirements And Capabilities

- Stop the machine and engage the parking brake. Install blocks in front of and behind the rear tires of the machine. Install blocks underneath and support the equipment securely before working under raised equipment.
- Keep bystanders clear of moving parts and the work area. Keep children away.
- Use increased caution on slopes and near banks and ditches to prevent overturn.
- Make certain that the Slow Moving Vehicle (SMV) emblem is installed so that it is visible and legible. When transporting the equipment, use the flashing warning lights (if equipped) and follow all local regulations.
- Operate this equipment with a machine equipped with an approved Roll-Over Protective Structure (ROPS). Always wear seat belt when the ROPS is up. Serious injury or death could result from falling off the machine.
- Before leaving the operator's position:
 1. Always park on a flat level surface.
 2. Place all controls in neutral.
 3. Engage the parking brake.
 4. Stop engine.
 5. Wait for all moving parts to stop.
- Carry passengers only in designated seating areas. Never allow riders on the machine or equipment. Falling off can result in serious injury or death.
- Start the equipment only when properly seated in the operator's seat. Starting a machine in gear can result in serious injury or death.
- Operate the machine and equipment from the operator's position only.
- The parking brake must be engaged before leaving the operator's seat. Roll away can occur because the transmission may not prevent machine movement.

Transport Safety

- Do not exceed 20 mph (32 kph). Reduce speed on rough roads and surfaces.
- Comply with state and local laws governing highway safety and movement of machinery on public roads.
- The use of flashing amber lights is acceptable in most localities. However, some localities prohibit their use.
- Local laws should be checked for all highway lighting and marking requirements.
- Always install transport locks, pins or brackets before transporting.
- Always yield to oncoming traffic in all situations and move to the side of the road so any following traffic may pass.
- Always enter curves or drive up or down hills at a low speed and at a gradual steering angle.
- Never allow riders on either tractor or equipment.
- Keep tractor / towing vehicle in a lower gear at all times when traveling down steep grades.
- Maintain proper brake settings at all times (if equipped).
- Stay away from overhead power lines when auger is raised. Electrocuting can occur without direct contact.

FIRE PREVENTION



Maintenance

- The machine and some equipment have components that are at high temperatures under normal operating conditions. The primary source of high temperatures is the engine and exhaust system. The electrical system, if damaged or incorrectly maintained, can be a source of arcs or sparks.
- Flammable debris (leaves, straw, etc.) must be removed regularly. If flammable debris is allowed to accumulate, it can cause a fire hazard. Clean often to avoid this accumulation. Flammable debris in the engine compartment is a potential fire hazard.
- All fuels, most lubricants and some coolant mixtures are flammable. Flammable fluids that are leaking or spilled onto hot surfaces or onto electrical components can cause a fire.

Operation

- The Farm King machine must be in good operating condition before use.
- Check all of the items listed on the service schedule under the 8 hour column before operation. (See Maintenance section)
- Do not use the machine where exhaust, arcs, sparks or hot components can contact flammable material, explosive dust or gases.

Fire Extinguishers



- Know where fire extinguishers and first aid kits are located and how to use them. Inspect the fire extinguisher and service the fire extinguisher regularly. Obey the recommendations on the instructions plate.

Electrical



- Check all electrical wiring and connections for damage. Keep the battery terminals clean and tight. Repair or replace any damaged part or wires that are loose or frayed. Battery gas can explode and cause serious injury. Do not jump start or charge a frozen or damaged battery. Keep any open flames or sparks away from batteries. Do not smoke in battery charging area.

Hydraulic System

- Check hydraulic tubes, hoses and fittings for damage and leakage. Never use open flame or bare skin to check for leaks. Hydraulic tubes and hoses must be properly routed and have adequate support and secure clamps. Tighten or replace any parts that show leakage. Always clean fluid spills. Do not use gasoline or diesel fuel for cleaning parts. Use commercial nonflammable solvents.

Fueling



- Stop the engine and let it cool before adding fuel. No smoking! Do not refuel a machine near open flames or sparks. Fill the fuel tank outdoors.

Welding And Grinding

- Always clean the machine and equipment, disconnect the battery, and disconnect the wiring from the machine controls before welding. Cover rubber hoses, battery and all other flammable parts. Keep a fire extinguisher near the machine when welding.
- Have good ventilation when grinding or welding painted parts. Wear dust mask when grinding painted parts. Toxic dust or gas can be produced.
- Dust generated from repairing nonmetallic parts such as hoods, fenders or covers can be flammable or explosive. Repair such components in a well ventilated area away from open flames or sparks.

GAS ENGINE SAFETY

- Before starting engine, read and understand the operating and maintenance instructions that came with your engine.
- DO NOT run engine in an enclosed area. Exhaust gases contain carbon monoxide, an odorless and deadly poison.
- DO NOT place hands or feet near moving or rotating parts.
- DO NOT store, spill, or use gasoline near an open flame, or devices such as a stove, furnace, or water heater which use a pilot light or devices which can create a spark.
- DO NOT refuel indoors where area is not well ventilated. Outdoor refueling is preferred.
- DO NOT refuel while engine is running. Allow engine to cool for 5 minutes before refueling. Store fuel in approved safety containers.
- DO NOT remove fuel tank cap while engine is running.
- DO NOT operate engine if gasoline is spilled. Move machine away from the spill and avoid creating any ignition until gasoline has evaporated.
- DO NOT smoke while filling fuel tank.
- DO NOT choke carburetor to stop engine. Whenever possible, gradually reduce engine speed before stopping.
- DO NOT run engine above rated speeds. This may result in injury.
- DO NOT tamper with governor springs, governor links or other parts which may increase the governed speed.
- DO NOT tamper with the engine speed selected by the original equipment manufacturer.
- DO NOT check for spark with spark plug or spark plug wire removed.
- DO NOT crank engine with spark plug removed. If engine is flooded, crank until engine starts.
- DO NOT strike flywheel with a hard object or metal tool as this may cause flywheel to shatter in operation. Use proper tools to service engine.
- DO NOT operate engine without a muffler. Inspect periodically and replace, if necessary. If engine is equipped with a muffler deflector, inspect periodically and replace, if necessary with correct deflector.
- DO NOT operate engine with an accumulation of grass, leaves, dirt or other combustible materials in the muffler area.
- DO NOT use this engine on any forest covered, brush covered, or grass covered unimproved land unless a spark arrester is installed on the muffler. The arrester must be maintained in effective working order by the operator.
- DO NOT touch hot muffler, cylinder or fins because contact may cause burns.
- DO NOT run engine with air cleaner or air cleaner cover removed.
- Remove the wire from the spark plug when servicing the engine or equipment to prevent accidental starting. Disconnect the negative wire from the battery terminal if equipped with a 12 volt starting system.
- Keep cylinder fins and governor parts free of grass and other debris which can affect engine speed.
- Examine muffler periodically to be sure it is functioning effectively. A worn or leaking muffler should be repaired or replaced as necessary.
- Use fresh gasoline. Stale fuel can gum carburetor and cause leakage.
- Check fuel lines and fittings frequently for cracks or leaks. Replace if necessary.

OPERATING SAFETY ZONE

Safety Zone Identification

	<h1>WARNING</h1>
AVOID INJURY OR DEATH	
<ul style="list-style-type: none"> • Do not allow small children, bystanders or unauthorized persons in the work area during operation. • Never stand or work under the auger and undercarriage when in the raised position or during operation. • Always keep PTO shields and all guards in place during operation. • Keep away from moving parts. • Keep everyone clear when operating the hopper mover. 	

	<h1>DANGER</h1>
ELECTROCUTION HAZARD	
<p>Keep away from power lines, electrocution can occur without direct contact.</p>	

	<h1>CAUTION</h1>
<ul style="list-style-type: none"> • Owners and operators should allow only authorized personnel and grain transport vehicles near the auger or inside the work area. • Allow adequate space for grain transport vehicles to operate safely. • Make certain everyone is clear of the equipment before applying power or moving the machine. • While in operation, always support the discharge end or provide adequate anchorage of the intake end to prevent sudden tipping. 	

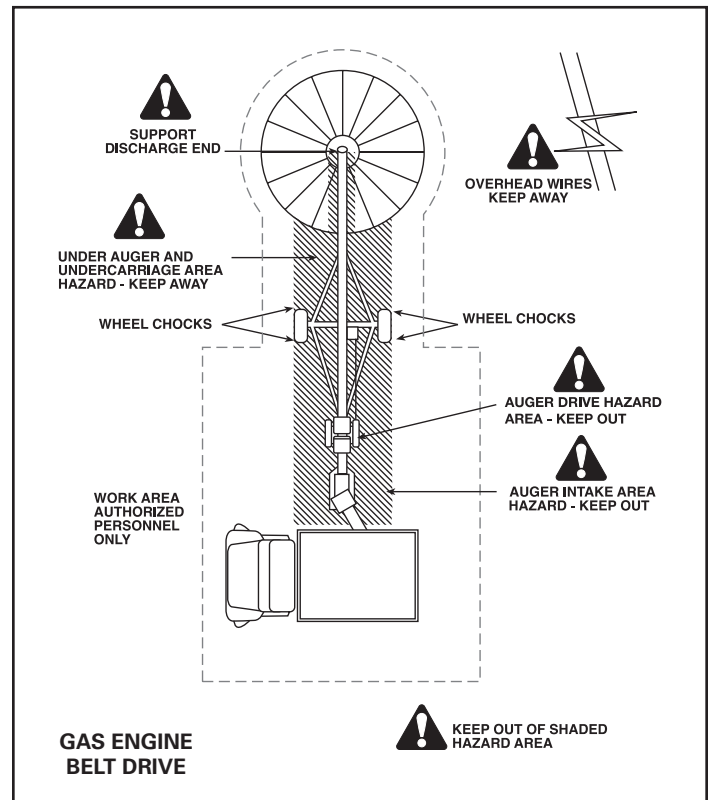

ASSEMBLY

GENERAL ASSEMBLY INFORMATION.....	19
Component Unloading And Identification.....	19
MOVER LIFT ASSEMBLY.....	20
MOVER WHEEL ASSEMBLY.....	24
HYDRAULIC PUMP BELT DRIVE ASSEMBLY.....	27
OIL TANK ASSEMBLY.....	30
CONTROL CONSOLE ASSEMBLY.....	31
HYDRAULIC HOSES ASSEMBLY.....	32
HOSE ROUTING SCHEMATIC.....	33

Farm King



GENERAL ASSEMBLY INFORMATION

Component Unloading And Identification

Unload the crate(s) and components in flat level area of adequate size to assemble the auger.

DANGER

ELECTROCUTION HAZARD

To prevent serious injury or death from electrocution:

- Be aware of overhead power lines.
- Keep away from power lines when unloading and assembling the auger.
- Electrocution can occur without direct contact.

WARNING





DO NOT permit bystanders to be in the work area when unloading and assembling components.

DO NOT work under suspended parts.

Keep away from moving parts.

Always use lifting devices / vehicles, chains or straps of adequate size and strength when unloading and assembling components.

IMPORTANT

Unload crate(s) and auger components carefully, not to cause damage to any of the components.

Using the packing list, locate and place all components and hardware in one area. Count the individual components and verify that you have received the correct number of components to fully assemble the auger.

If any components are damaged, missing or replacement parts are required, contact your Farm King Dealer.

Assemble the auger mover in the following order:

1. Undercarriage lift
2. Drive wheels
3. Hydraulic pump
4. Hydraulic hoses

Figure 3

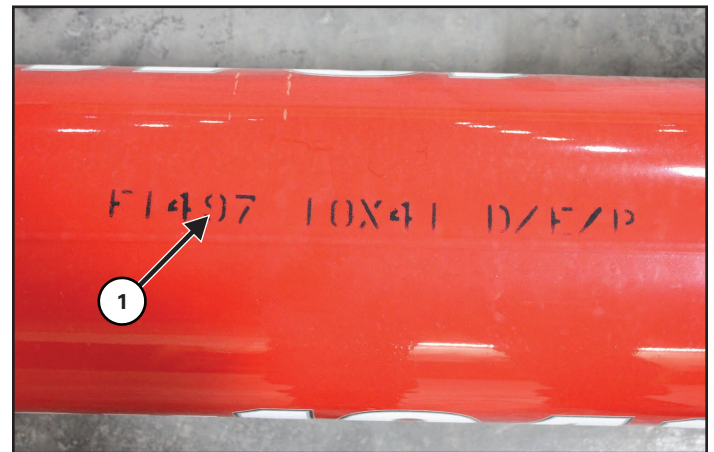

Larger components are marked for identification [Figure 3].

MOVER LIFT ASSEMBLY

Assemble the mover components on a flat level surface.

WARNING

DO NOT permit bystanders to be in the work area when unloading and assembling components.

DO NOT work under suspended parts.

Keep away from moving parts.

Always use lifting devices / vehicles, chains or straps of adequate size and strength when unloading and assembling components.

Figure 4

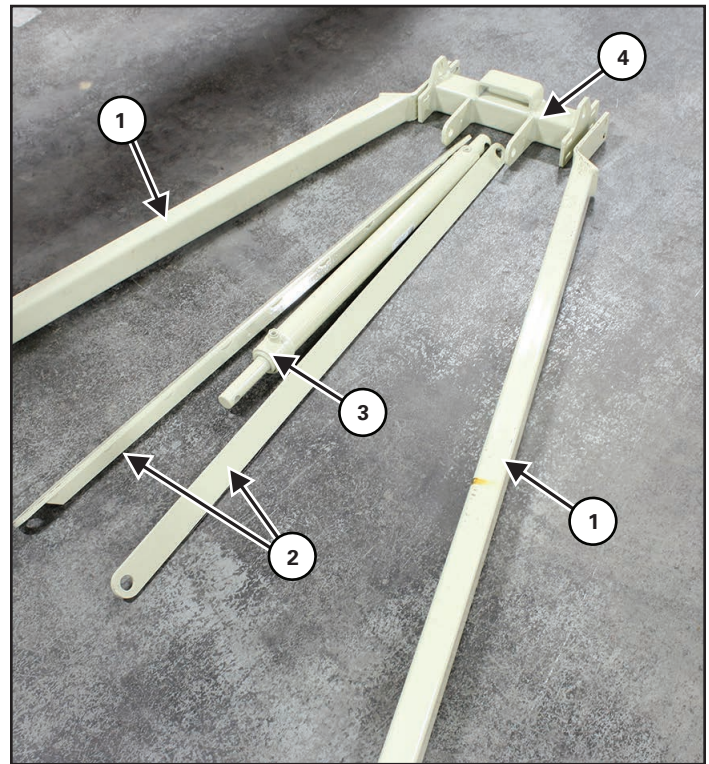

Arrange the mover lift components for assembly:

- RH and LH lift frame (Item 1) [Figure 4]
- RH and LH lower lift arms (Item 2) [Figure 4]
- 2" hydraulic cylinder (Item 3) [Figure 4]
- Front bracket (Item 4) [Figure 4]

IMPORTANT

The directions left, right, front and rear, as mentioned throughout this manual, are as viewed as the operator sitting in the tractor's seat with the equipment hitched to the tractor.

WARNING

AVOID INJURY OR DEATH

Keep fingers and hands out of pinch points when assembling the equipment.

Figure 5

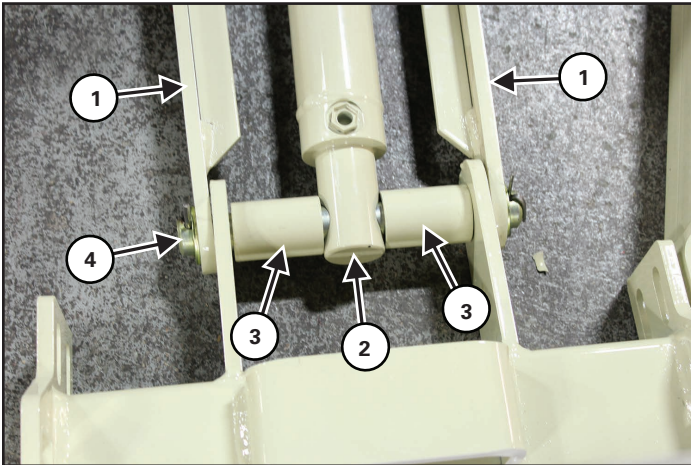

Position the RH and LH lower lift arms (Item 1) [Figure 5] with the front bracket.

Position the 2" hydraulic cylinder (Item 2) and two spacers (Item 3) [Figure 5] with the front bracket.

Attach all components and bracket using one 1" X 8.82" pin, two 1" rim washers, and two 3/16" X 2" cotter pin (Item 4) [Figure 5].

Figure 6

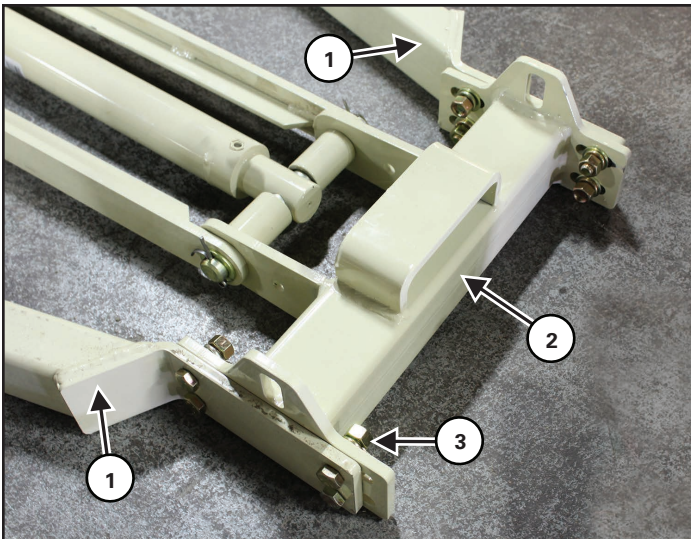

Install the RH and LH lift frames (Item 1) to the front bracket (Item 2). Attach each lift frame using four 1/2" x 1-1/2" hex bolts, four 1/2" flat washers, and four 1/2" lock nuts (Item 3) [Figure 6].

Figure 7

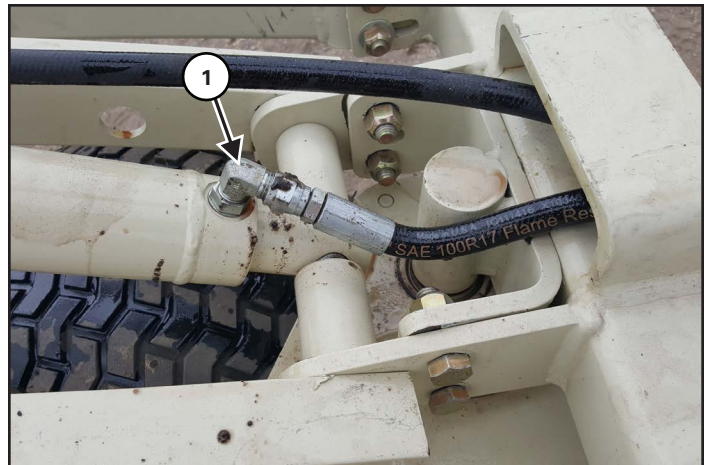

Install two -6MORB x -6MJIC elbow fittings (Item 1) [Figure 7] to the 2" hydraulic cylinder.

	<h1 style="margin: 0;">IMPORTANT</h1>
<p>Turn the elbow fittings 30 degrees to prevent hose pinching by the lift arms.</p> <p>[Figure 7] depicts assembled equipment with elbow fittings and hoses installed.</p>	

Figure 8



Move the castor wheel assembly (Item 1) [Figure 8] to the work area.

Attach the pivot shaft and bracket to the front bracket using four 1/2" x 1-1/2" hex bolts and four 1/2" lock nuts (Item 2) [Figure 8].

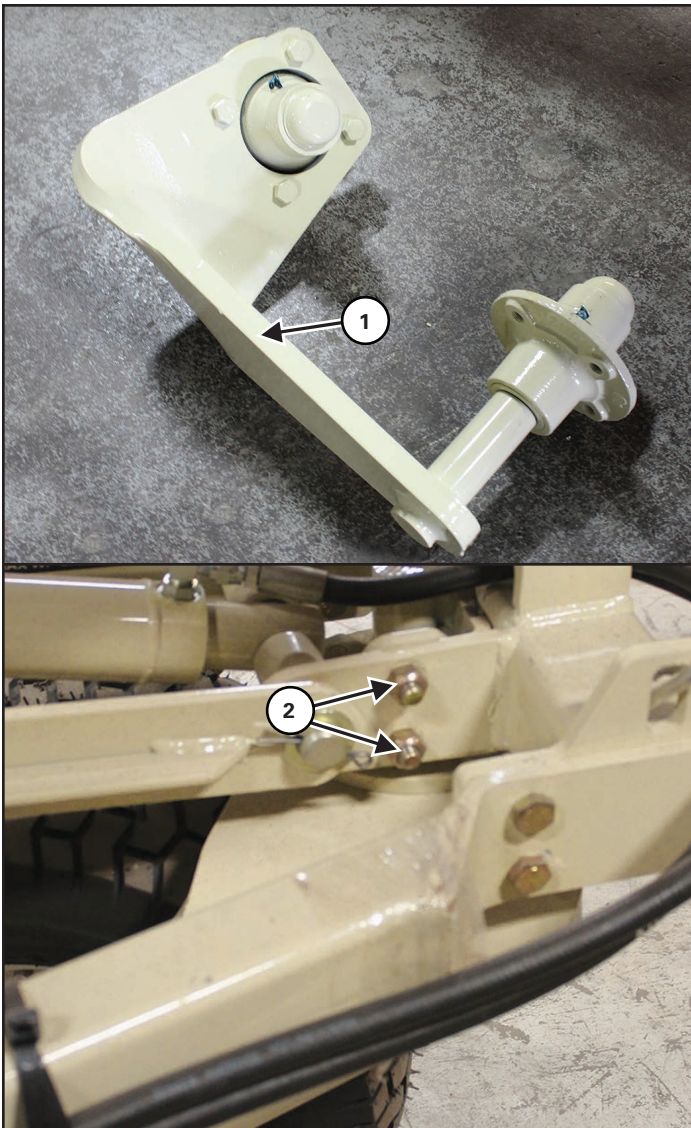
Figure 9



Install the wheel and tire (Item 1) to the castor pivot hub. Attach using four wheel bolts (Item 2) [Figure 9].

	WARNING
	
<p>DO NOT permit bystanders to be in the work area when unloading and assembling components.</p> <p>DO NOT work under suspended parts.</p> <p>Keep away from moving parts.</p> <p>Always use lifting devices / vehicles, chains or straps of adequate size and strength when unloading and assembling components.</p>	

Figure 10

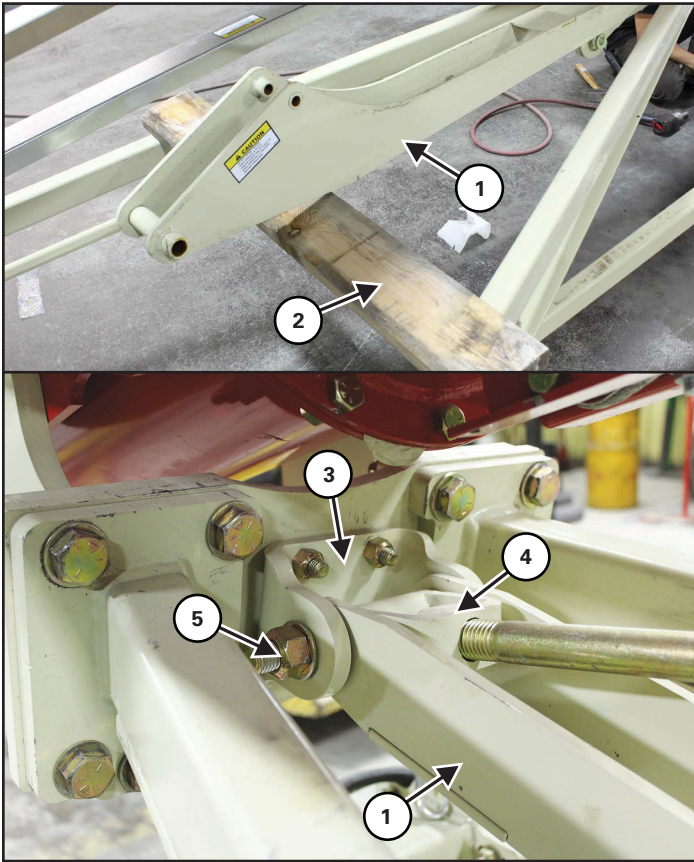

Support the upper lift arm (Item 1) using a board (Item 2) [Figure 10] or other support.

Attach the lift arm (Item 1) to the auger tube mount (Item 3). Remove the pivot pulley (Item 4) and associated hardware (Item 5) [Figure 10].

Position the lift arm and reinstall associated hardware including 3/4" x 7-1/2" hex bolt, 1" bushing, 3/4" flat washers, and 3/4" lock nut.

Figure 11

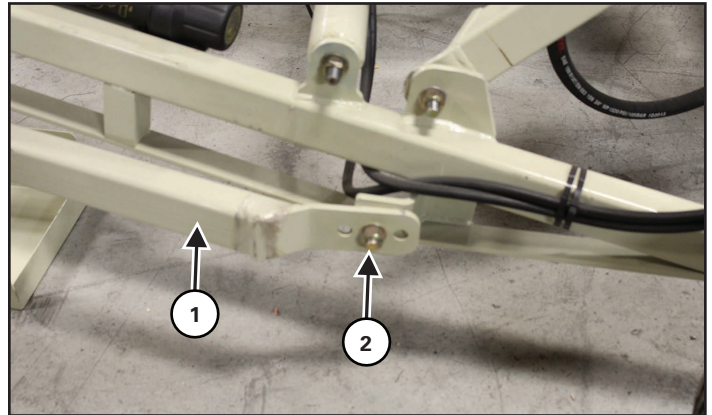

Install the LH and RH lift frames (Item 1) to the undercarriage. Attach using one 3/4" x 2" hex bolt, one 3/4" flat washer, and one 3/4" lock nut (Item 2) [Figure 11].

Figure 12

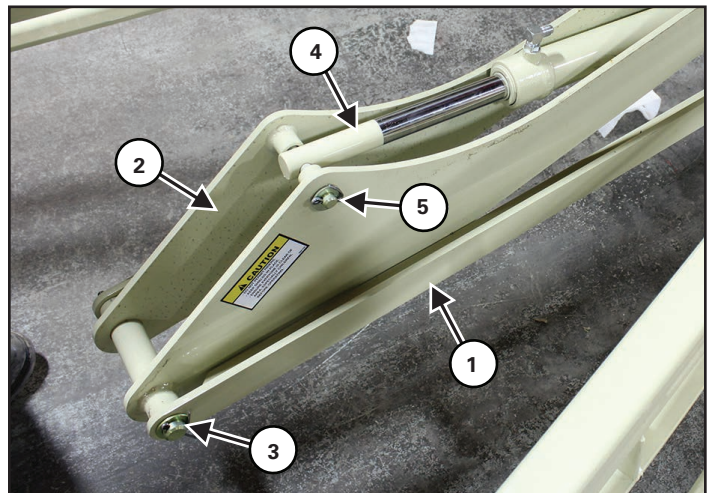

Install the LH and RH lower lift arms (Item 1) to the upper lift arm (Item 2). Attach using one 1" X 8.82" pin, two 1" rim washers, and two 3/16" X 2" cotter pins (Item 3) [Figure 12].

Extend the cylinder rod (Item 4) to the mount on the upper lift arm. Attach using one 5/8" x 5-1/2" pin, two 5/8" flat washer, and one 3/16" X 2" cotter pin (Item 5) [Figure 12].

61' Models: Install one cylinder stroke extender to the cylinder rod before attaching to the lift arm (Item 2) [Figure 12].

MOVER WHEEL ASSEMBLY

Figure 13

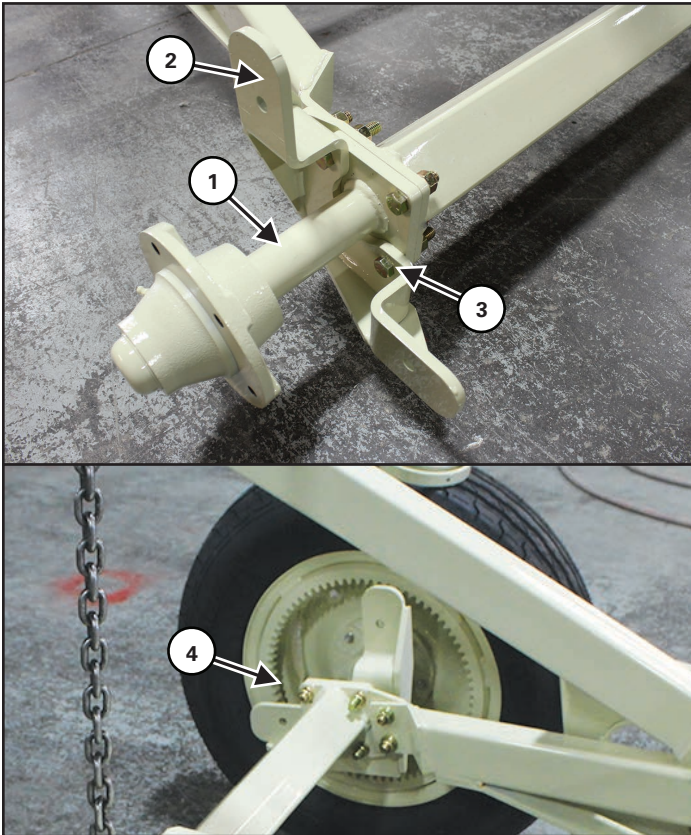

Remove wheel, hub (Item 1) [Figure 13], and associated hardware.

Reposition hub (Item 1) with the hydraulic motor mount (Item 2). Attach with three 1/2" x 2-1/2" hex bolts and three 1/2" lock nuts (Item 3) [Figure 13].

Install the geared wheel (Item 4) [Figure 13] and wheel bolts to the hub.

Repeat for the opposite wheel and hub.

Figure 14

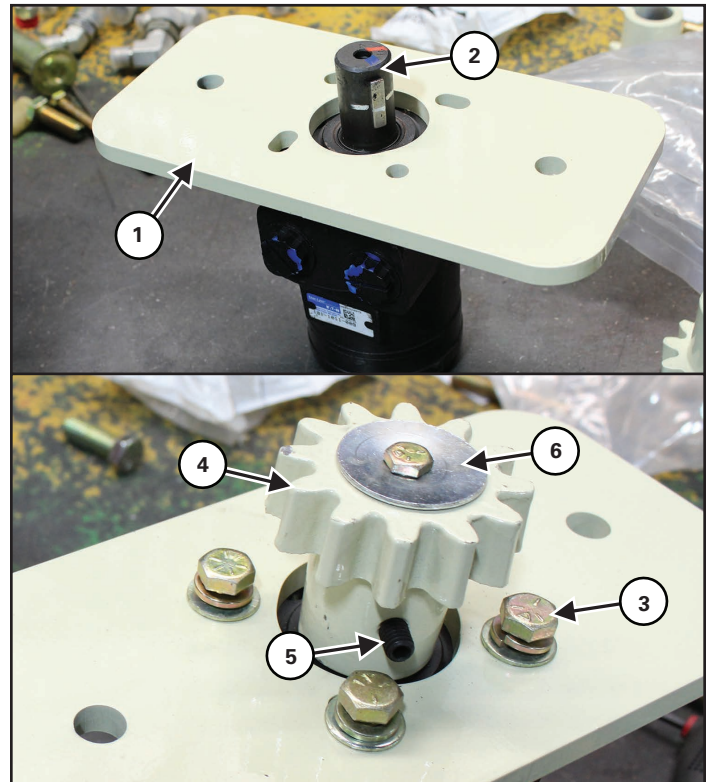

Position the hydraulic motor plate (Item 1) over the hydraulic motor drive shaft (Item 2) [Figure 14].

Attach the plate using four 3/8" x 1" hex bolts and four 3/8" flat washers (Item 3) [Figure 14]. Hand tighten bolts to still allow movement.

Position the motor gear (Item 4) on the motor drive shaft. Install one 5/16" x 1/2" set screw (Item 5) [Figure 14] to the motor gear.

Attach motor gear using one 1/4" x 1-1/2" hex bolt and one wide washer (Item 6) [Figure 14].

Figure 15

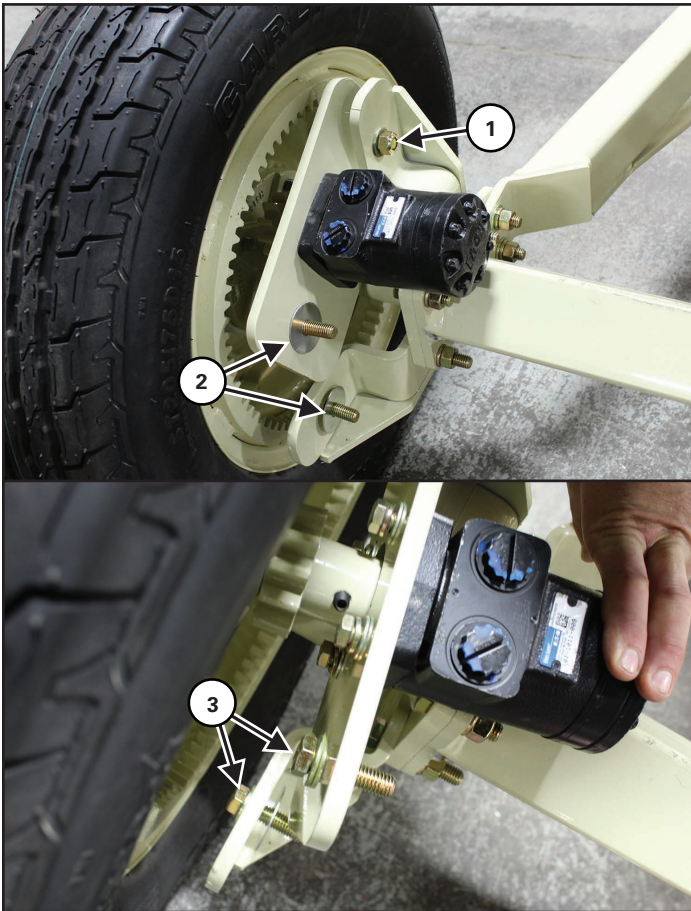

Position the hydraulic motor / plate with the motor mount. Attach the plate at the top mount using one 1/2" x 1-3/4" hex bolt, two 1/2" flat washers (both sides), and one 1/2" lock nut (Item 1) [Figure 15].

Place one 1/2" x 1-3/4" hex bolt (Item 2), one 1/2" flat washer, and one wide washer (Item 3) [Figure 15] at the two other holes on the plate and mount.

Repeat assembly for opposite wheel.

Figure 16

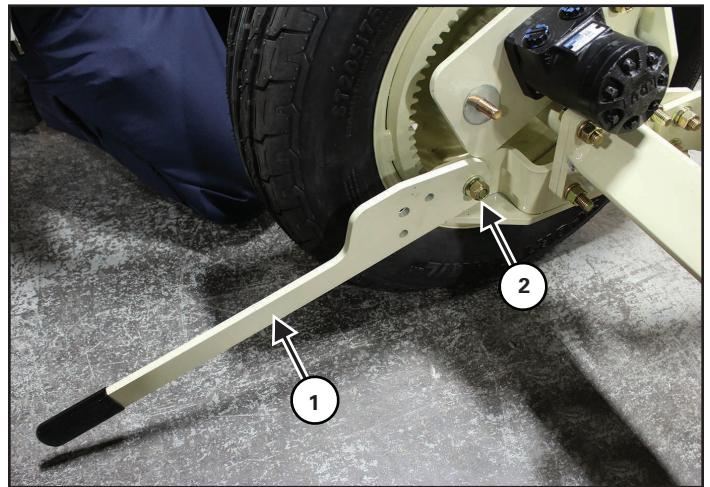

Install one lever (Item 1) to the bottom mount. Attach using one 1/2" flat washer and 1/2" lock nut (Item 2) [Figure 16].

Repeat assembly for opposite wheel.

	WARNING
	
<p>AVOID INJURY OR DEATH</p> <p>Keep fingers and hands out of pinch points when assembling the equipment.</p>	

Figure 17

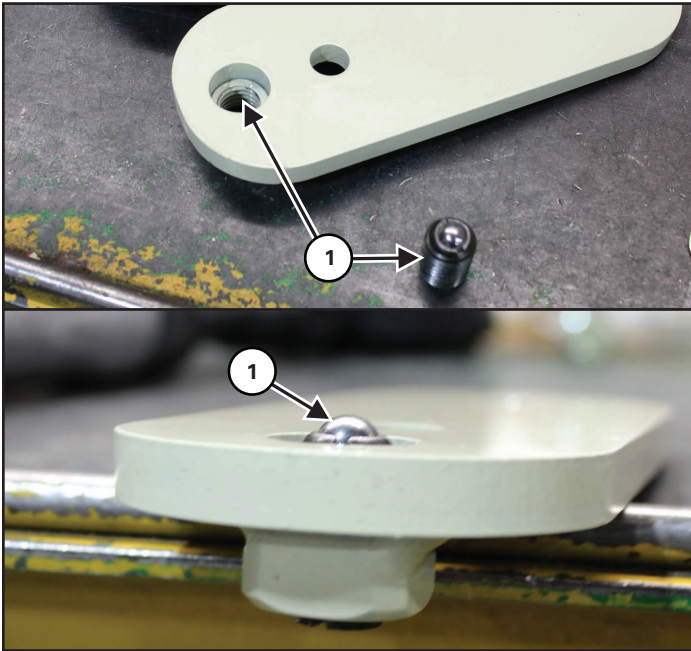

Install one 5/8" ball nose screw (Item 1) [Figure 17] to one motor link.

Repeat for one other motor link and ball nose screw.

Figure 18

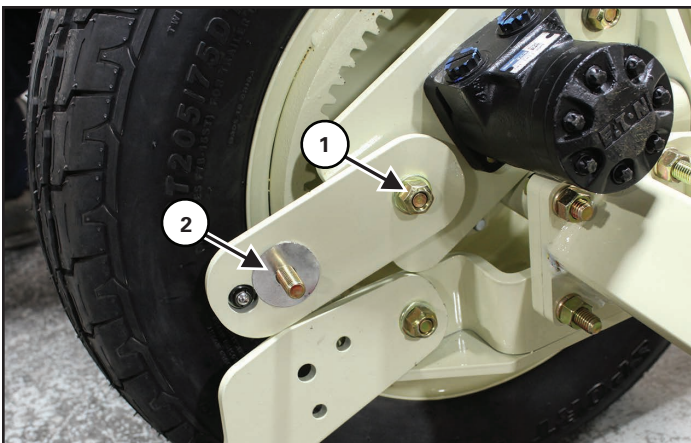

Install one motor link to the motor plate. Attach using one 1/2" flat washer and one 1/2" lock nut (Item 1) [Figure 18].

Place one 1/2" x 1-3/4" hex bolt and one wide washer (Item 2) [Figure 18] at the motor link hole.

Repeat assembly for opposite wheel.

Figure 19



Attach the motor link to the middle hole on the lever using one 1/2" flat washer and one 1/2" lock nut (Item 1) [Figure 19].

Torque all 1/2" bolts of the leverage system to 35 ft-lbs.

Perform the following to adjust the gears for best engagement:

1. Disengage the gears.
2. Move motor on the slotted plate toward gear engagement.
3. Perform a full motion of the lever in order for the gears to be self adjusted.
4. Tighten the 3/8" bolts attaching the motor to the slotted plate.

Repeat for opposite wheel.

Figure 20

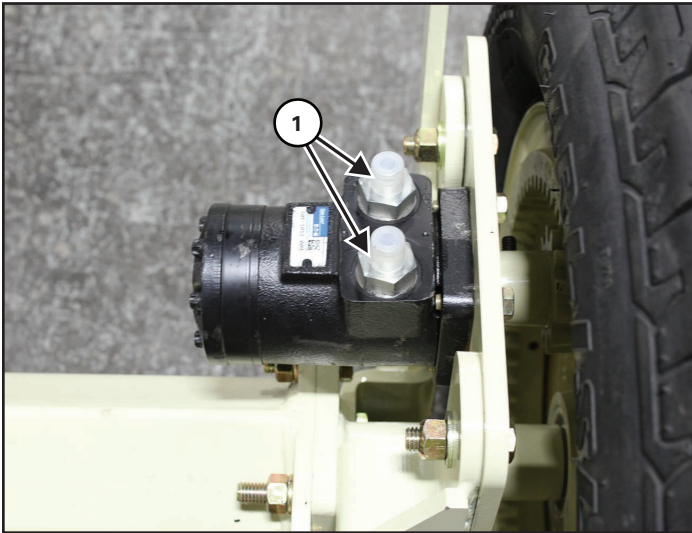

Install two -10 MORB x -6 MJIC adapters (Item 1) [Figure 20] to hydraulic motor ports.

Repeat assembly for opposite wheel.

HYDRAULIC PUMP BELT DRIVE ASSEMBLY

Figure 21

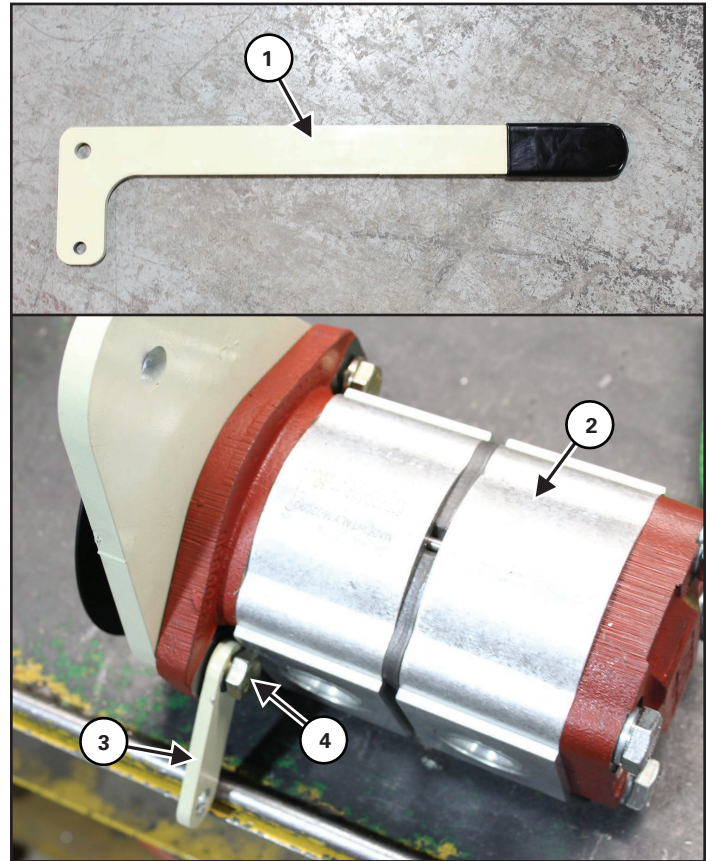

Bring the lever (Item 1) and hydraulic pump assembly (Item 2) [Figure 21] to the work area.

Install one link (Item 3) to the pump using one 3/8" x 1-1/4" hex bolt and one 3/8" flat washer (Item 4) [Figure 21].

Figure 22

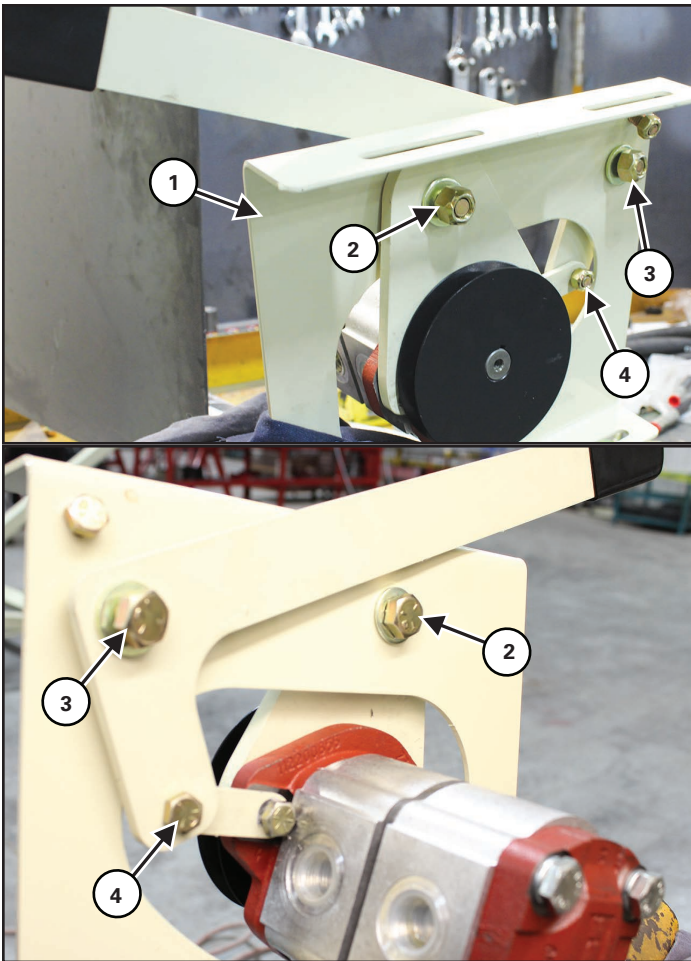

Install the pump assembly to the pump mount bracket (Item 1). Attach using one 1/2" x 1-1/2" hex bolt, two 1/2" flat washer (both sides), and one 1/2" lock nut (Item 2) [Figure 22].

Position the lever on the pump mount bracket. Attach to the bracket using one 1/2" x 1-1/2" hex bolt, two 1/2" flat washer (both sides), and one 1/2" lock nut (Item 2) [Figure 22].

Attach the lever to the link using one 3/8" x 1-1/4" hex bolt, two 3/8" flat washers (both sides), and one 3/8" lock nut (Item 3) [Figure 22].

Figure 23

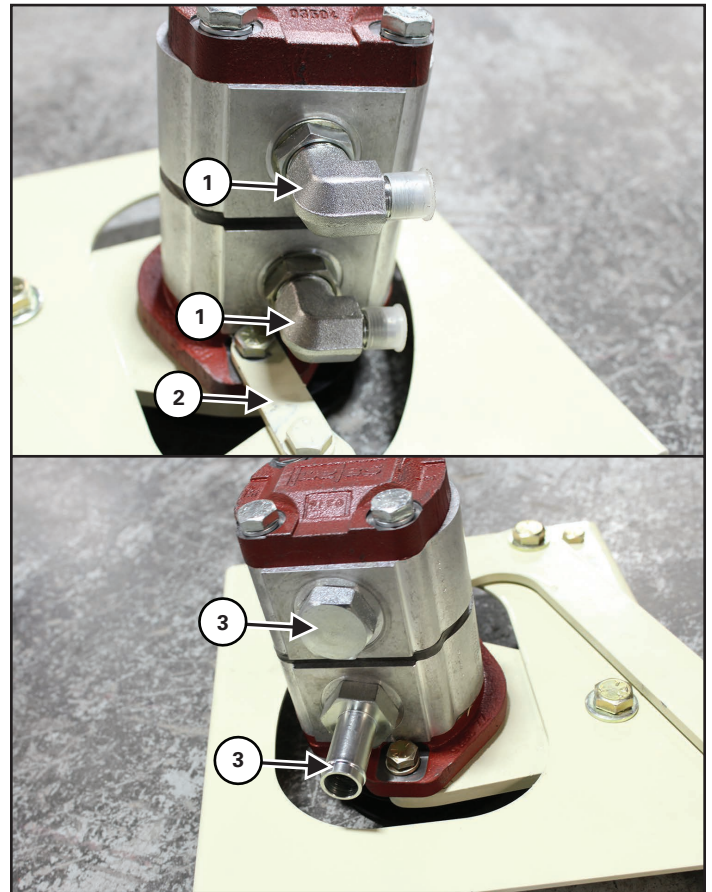

Install two -10 MORB x -6 MJIC elbows (Item 1) to the hydraulic pump ports on the same side as the link (Item 2) [Figure 23].

Install one -12 MORB hex head plug (Item 3) and one -12 MORB x -12 barb adapter (Item 4) [Figure 23] to the opposite side ports.

Apply Teflon tape to threads.

Figure 24

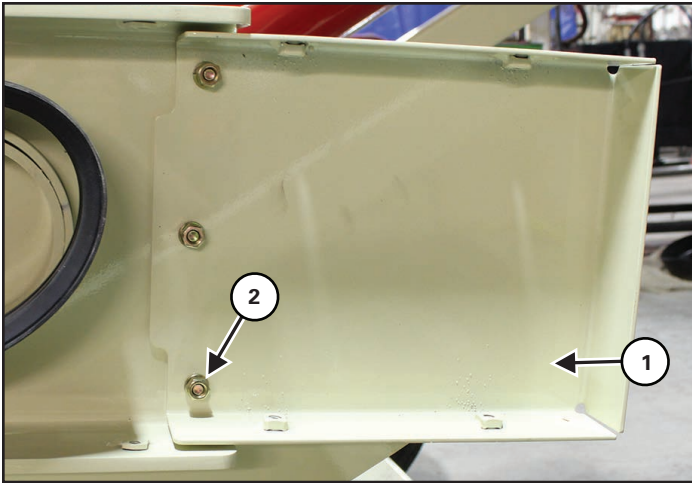

Remove existing covers from the belt drive guard.

Install hydraulic pump cover (Item 1) to the belt drive guard. Attach using three 3/8" x 1" hex bolts and three 3/8" lock nuts (Item 2) [Figure 24].

Figure 25

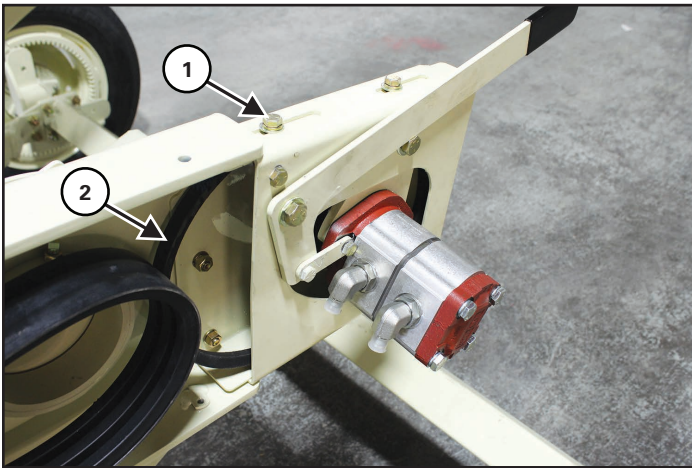

Install the mount and pump assembly to the belt drive guard. Attach using four 3/8" x 1" hex bolts and four 3/8" flat washers (Item 1) [Figure 25].

Place one hydraulic pump belt (Item 2) [Figure 25] on the pulley.

Figure 26

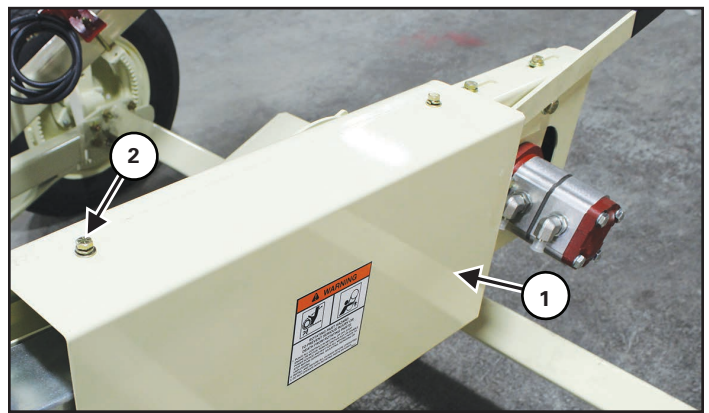

Install the belt drive cover (Item 1). Attach using four 5/16" x 3/4" hex bolts and four 5/16" flat washers (Item 2) [Figure 26].

OIL TANK ASSEMBLY

Figure 27

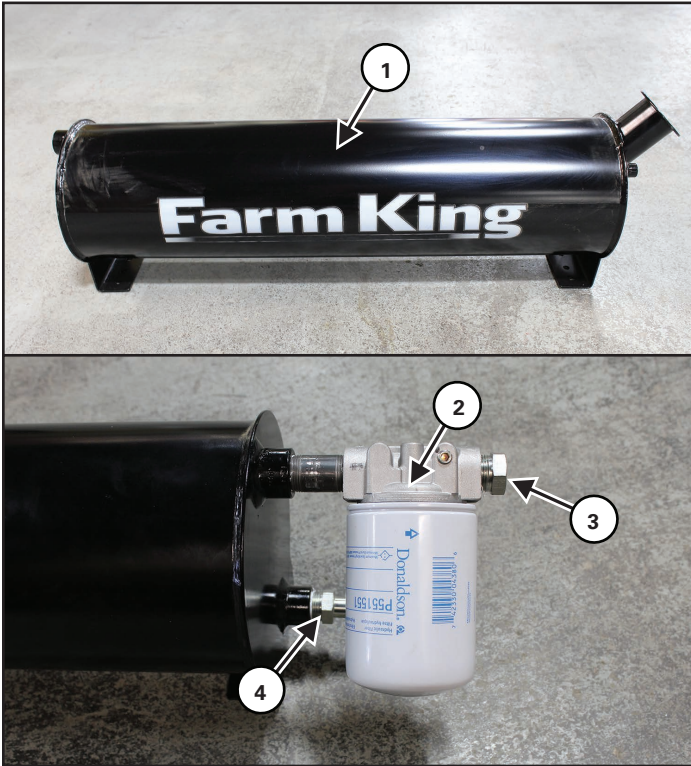

Bring the oil tank (Item 1) [Figure 27] to the assembly area.

Install one 10 micron oil filter (Item 2) to the top port of the tank. Install one plug (Item 3) [Figure 27] to the filter.

Install one -12 MPT x -12 hose barb (Item 4) [Figure 27] to the bottom port of the tank.

Apply Teflon tape to threads.

Figure 28

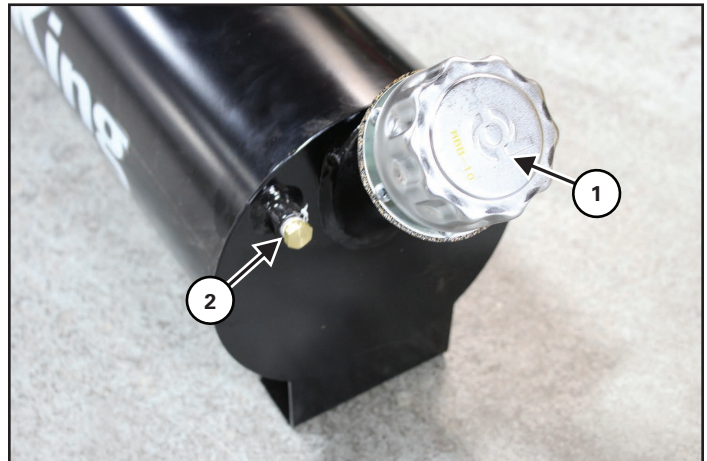

Install one fill cap (Item 1) [Figure 28] to the tank.

Install one -4 MPT plug (Item 2) [Figure 28] to the front port.

Apply Teflon tape to threads.

Figure 29

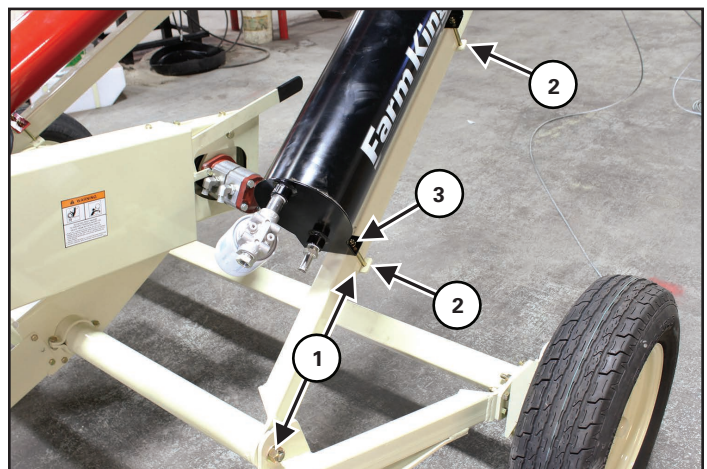

Position the oil tank on the LH lift arm 20" (Item 1) [Figure 29] from the arm pivot bolt.

Position two mounting plates (Item 2) beneath the lift arm and tank mounts. Attach each mount plate using two 3/8" x 4" hex bolts and two 3/8" lock nuts (Item 3) [Figure 29].

CONTROL CONSOLE ASSEMBLY

Figure 30

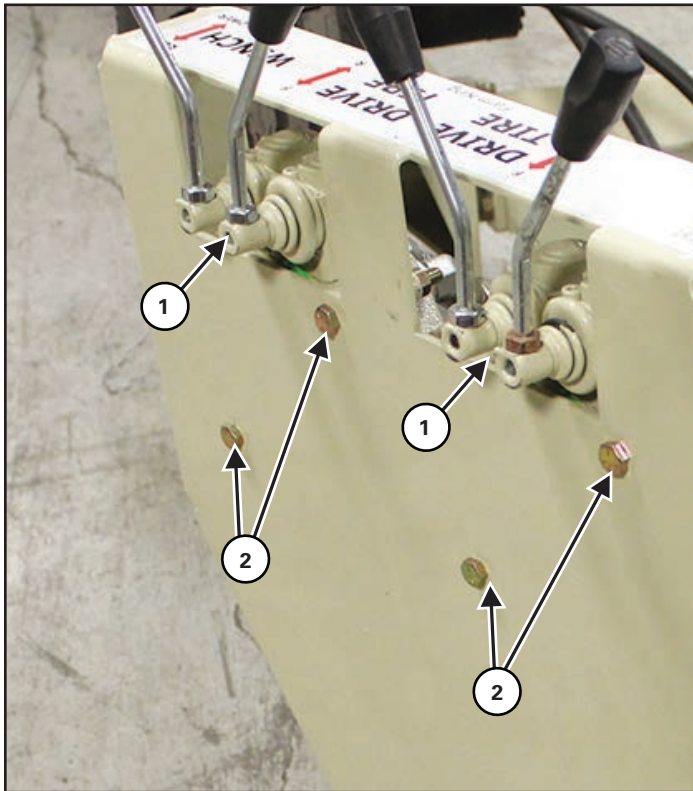

Install two valve blocks (Item 1) to the console bracket. Attach each valve block using two 5/16" x 2-1/2" hex bolts, two 5/16" flat washers, and two 5/16" lock nuts (Item 2) [Figure 30].

Figure 31

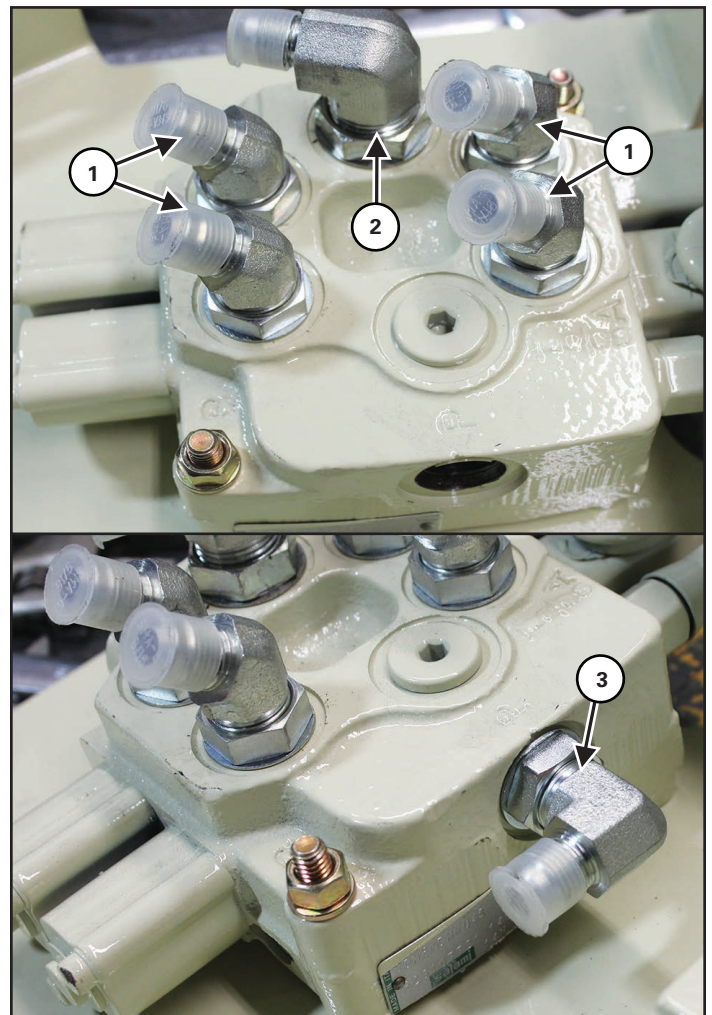

Remove plugs and install four -8 MORB x -6 MJIC 45 degree elbows (Item 1) [Figure 31] to the work ports of the valve block.

Remove plug and install one -10 MORB x -6 MJIC 90 degree elbow (Item 2) [Figure 31] to the return port.

Remove plug and install one -8 MORB x -6 MJIC 90 degree elbow (Item 3) [Figure 31] to the supply port.

Apply Teflon tape to threads.

Repeat for other valve block.

Figure 32

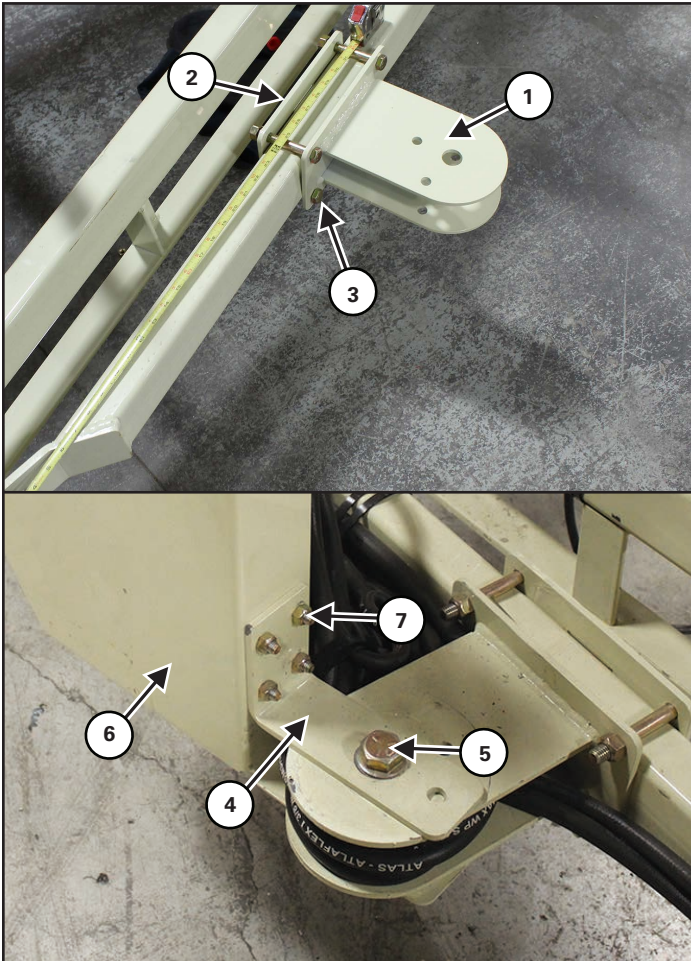

Place the console mounting bracket (Item 1) [Figure 32] on the RH undercarriage weldment. Position the mounting bracket 24" from the end of the undercarriage weldment.

Position one mounting plate (Item 2) behind the mounting bracket and undercarriage weldment. Attach using four 1/2" x 3-1/2" hex bolts and four 1/2" lock nuts (Item 3) [Figure 32].

Install one pivot plate (Item 4) to the mounting bracket. Attach using one 1" pin (Item 5) [Figure 32] and one 1/4" x 2" cotter pin.

Install the console bracket (Item 6) to the pivot plate. Attach using four 3/8" x 1" hex bolts, eight 3/8" flat washers (both sides), and four 3/8" lock nuts (Item 7) [Figure 32].

HYDRAULIC HOSES ASSEMBLY

Figure 33

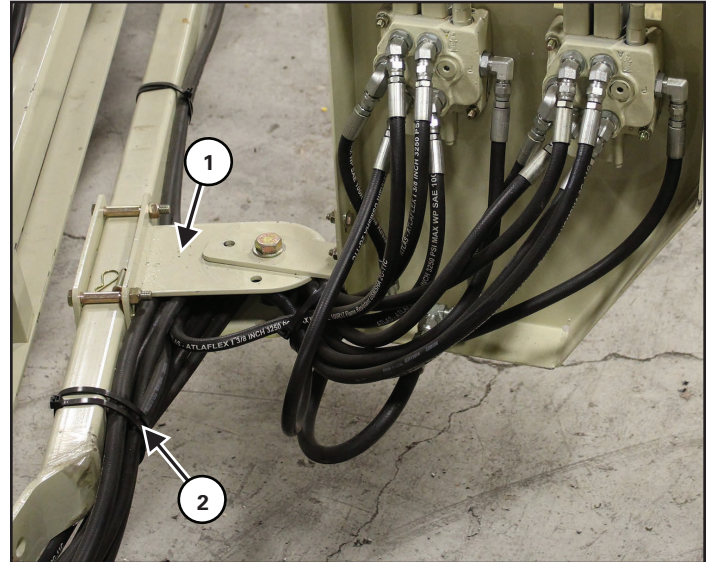

Connect hydraulic hoses to the correct valves on the control console (see Hose Routing Schematic on page 33).

Route hoses from the control console through the mounting bracket (Item 1) [Figure 33].

Group hoses together and attach to frame using zip ties (Item 2) [Figure 33].

HOSE ROUTING SCHEMATIC

Figure 34

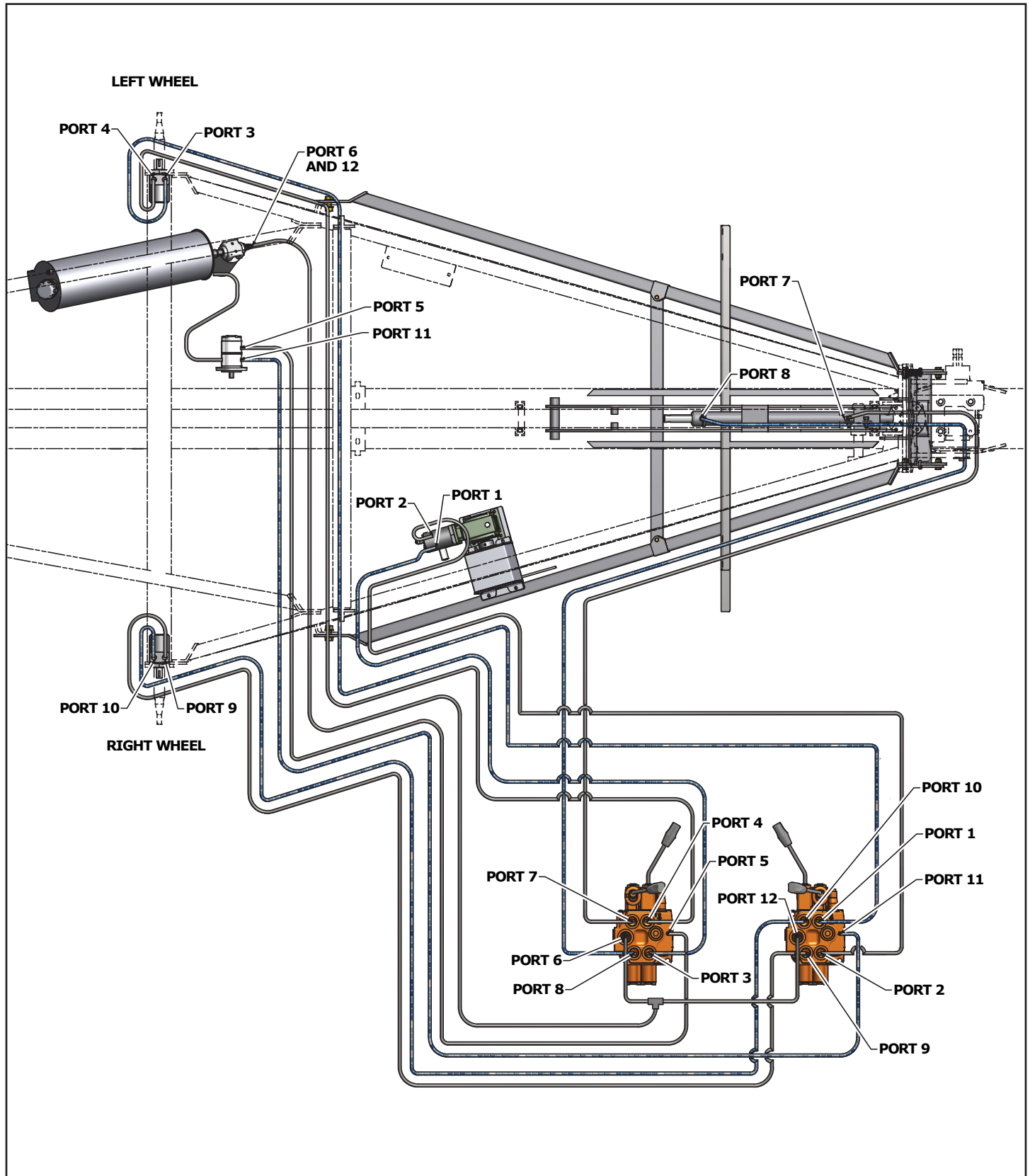

Hose Routing [Figure 34].

PORT	HOSE DESCRIPTION	ROUTE	LENGTH (IN.)
41 FT. MODELS			
1	HOSE-6 X -6JIC X -6JIC 90 ELBOW	CONTROL VALVE TO HYD WINCH	117
2	HOSE-6 X -6JIC X -6JIC 90 ELBOW	CONTROL VALVE TO HYD WINCH	117
3	HOSE-6 X -6JIC X -6JIC 90 ELBOW	CONTROL VALVE TO LH WHEEL MOTOR	159
4	HOSE-6 X -6JIC X -6JIC 90 ELBOW	CONTROL VALVE TO LH WHEEL MOTOR	159
5	HOSE-6 X -6JIC X -6JIC	CONTROL VALVE TO HYD PUMP	123
6	HOSE-8 X -8JIC X -8JIC	CONTROL VALVE TO OIL FILTER	139.5
7	HOSE-6 X -6JIC X -6JIC	CONTROL VALVE TO LOWER HYD CYL PORT	134
8	HOSE-6 X -6JIC X -6JIC	CONTROL VALVE TO UPPER HYD CYL PORT	163
9	HOSE-6 X -6JIC X -6JIC 90 ELBOW	CONTROL VALVE TO RH HYD WHEEL MOTOR	83
10	HOSE-6 X -6JIC X -6JIC 90 ELBOW	CONTROL VALVE TO RH HYD WHEEL MOTOR	83
11	HOSE-6 X -6JIC X -6JIC	CONTROL VALVE TO PUMP	123
12	HOSE-8 X -8JIC X -8JIC	CONTROL VALVE TO OIL FILTER	139.5
51 FT. MODELS			
1	HOSE-6 X -6JIC X -6JIC 90 ELBOW	CONTROL VALVE TO HYD WINCH	115
2	HOSE-6 X -6JIC X -6JIC 90 ELBOW	CONTROL VALVE TO HYD WINCH	115
3	HOSE-6 X -6JIC X -6JIC 90 ELBOW	CONTROL VALVE TO LH HYD WHEEL MOTOR	195
4	HOSE-6 X -6JIC X -6JIC 90 ELBOW	CONTROL VALVE TO LH HYD WHEEL MOTOR	195
5	HOSE-6 X -6JIC X -6JIC	CONTROL VALVE TO HYD PUMP	139
6	HOSE-8 X -8JIC X -8JIC	CONTROL VALVE TO OIL FILTER	161.25
7	HOSE-6 X -6JIC X -6JIC	CONTROL VALVE TO LOWER HYD CYL PORT	156
8	HOSE-6 X -6JIC X -6JIC	CONTROL VALVE TO UPPER HYD CYL PORT	189
9	HOSE-6 X -6JIC X -6JIC 90 ELBOW	CONTROL VALVE TO RH HYD WHEEL MOTOR	93
10	HOSE-6 X -6JIC X -6JIC 90 ELBOW	CONTROL VALVE TO RH HYD WHEEL MOTOR	93
11	HOSE-6 X -6JIC X -6JIC	CONTROL VALVE TO HYD PUMP	139
12	HOSE-8 X -8JIC X -6JIC	CONTROL VALVE TO OIL FILTER	161.25
61 FT. MODELS			
1	HOSE-6 X -6JIC X -6JIC 90 ELBOW	CONTROL VALVE HYD WINCH	127
2	HOSE-6 X -6JIC X -6JIC 90 ELBOW	CONTROL VALVE HYD WINCH	127
3	HOSE-6 X -6JIC X -6JIC 90 ELBOW	CONTROL VALVE TO LH HYD WHEEL MOTOR	220
4	HOSE-6 X -6JIC X -6JIC 90 ELBOW	CONTROL VALVE TO LH HYD WHEEL MOTOR	220
5	HOSE-6 X -6JIC X -6JIC	CONTROL VALVE TO HYD PUMP	161
6	HOSE-8 X -8JIC X -8JIC	CONTROL VALVE TO OIL FILTER	200
7	HOSE-6 X -6JIC X -6JIC	CONTROL VALVE TO LOWER HYD CYL PORT	185
8	HOSE-6 X -6JIC X -6JIC	CONTROL VALVE TO UPPER HYD CYL PORT	217
9	HOSE-6 X -6JIC X -6JIC 90 ELBOW	CONTROL VALVE TO RH HYD WHEEL MOTOR	102
10	HOSE-6 X -6JIC X -6JIC 90 ELBOW	CONTROL VALVE TO RH HYD WHEEL MOTOR	102
11	HOSE-6 X -6JIC X -6JIC	CONTROL VALVE TO HYD PUMP	161
12	HOSE-8 X -8JIC X -8JIC	CONTROL VALVE TO OIL FILTER	200

OPERATION

GENERAL INFORMATION.....	37
Pre - Operation Checklist.....	37
Break - In Checklist.....	38
Gas Engine Requirements.....	38
ENTERING & LEAVING THE OPERATOR'S POSITION.....	39
Entering The Operator's Position.....	39
Leaving The Operator's Position.....	39
GAS ENGINE BELT DRIVE.....	39
MOVING AUGER.....	40
RAISING / LOWERING AUGER.....	41
Hydraulic Winch.....	41
TRANSPORTING.....	42

Farm King





GENERAL INFORMATION

Pre - Operation Checklist

Before operating the auger for the first time and each time thereafter, check the following items:

	WARNING
AVOID INJURY OR DEATH	
<p>Wear safety glasses to prevent eye injury when any of the following conditions exist:</p> <ul style="list-style-type: none"> • When fluids are under pressure. • Flying debris or loose material is present. • Engine is running. • Tools are being used. 	

1. Lubricate the equipment per the schedule outline in the Maintenance Section.
2. Check the augers. Remove any material build-up or debris that has become entangled.
3. Make sure that all guards and shields are in place, secured and functioning as designed.

	WARNING
	
HIGH PRESSURE FLUID HAZARD	
<p>Leaking fluids under pressure can enter the skin and cause serious injury or death. Immediate medical attention is required. Wear goggles. Use cardboard to check for leaks.</p>	

4. Check condition of all hydraulic components for leaks. Repair as required.

Note: Do not operate with hydraulic leaks.

5. Check and tighten all wheel bolts to proper torque.
6. Check tire pressure. Inflate per manufacturer's specification.
7. Check gearbox oil level. Fill as required. (See Maintenance section).
8. Check the drive belt tension and alignment. Tension or align as required. (See Maintenance section).
9. Use only an engine of adequate power to operate the machine.

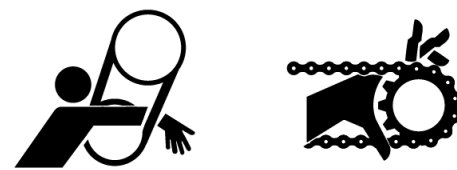
	WARNING
	
ROTATING PART HAZARD	
<p>To prevent serious injury or death from rotating parts:</p> <ul style="list-style-type: none"> • Place all controls in neutral or off, stop engine or motor, remove ignition key or disable power source and wait for all moving parts to stop before servicing, adjusting, repairing or unplugging. • Install and secure all guards / shields before operating. • Do not operate with rotating parts exposed. 	

Break - In Checklist

There are no operational restrictions on the auger or auger mover when used for the first time. It is recommended that the following mechanical items be checked:

Before starting work:

1. Review the operator’s manual of the auger mover and power unit.

Check the following mechanical items after 1 hour of operation and again after 10 hours of operation:

1. Re-torque wheel bolts to proper torque and check tire pressure.
2. Check for loose fasteners and hardware. Tighten as required.
3. Check the belt tension and alignment. Tension or align as required (See Maintenance section).
4. Check the condition of all hydraulic lines, hoses, fittings and couplers for damage or leaks.
5. Tighten leaking fittings and repair or replace any damaged components.
6. Check the condition of all electrical lines, wires, and connections. Repair or replace any damaged systems or components.
7. Check that all guards and shields are in place, secured and functioning as designed.

Gas Engine Requirements

The CX2 Series Conventional Auger Mover is designed to be used with an engine of appropriate power. The following horsepower specifications must be maintained when selecting an engine.

Figure 35

Auger	Minimum Horsepower Requirement	
	8" Tube	10" Tube
41'	16 hp	28 hp
51'	20 hp	32 hp
61'	24 hp	38 hp

WARNING

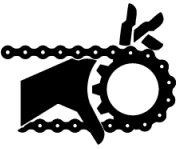
ROTATING PART HAZARD

To prevent serious injury or death from rotating parts:

- Place all controls in neutral or off, stop engine or motor, remove ignition key or disable power source and wait for all moving parts to stop before servicing, adjusting, repairing or unplugging.
- Install and secure all guards / shields before operating.
- Do not operate with rotating parts exposed.

ENTERING & LEAVING THE OPERATOR'S POSITION

Entering The Operator's Position

Enter the operator's position, start the engine, and release the parking brake.

	<h1 style="margin: 0;">IMPORTANT</h1>
<p>Follow the instructions in your tractor's operation manual for the correct procedure.</p>	

Leaving The Operator's Position

Always perform the following steps when leaving the operator's position:

	<h1 style="margin: 0;">WARNING</h1>
<h2 style="margin: 0;">AVOID INJURY OR DEATH</h2>	
<p>Before you leave the operator's position:</p> <ul style="list-style-type: none"> Always park on a flat level surface. Place all controls in NEUTRAL. Engage the park brake. Stop the engine and remove the key. Wait for all moving parts to stop. 	

GAS ENGINE BELT DRIVE

Figure 36

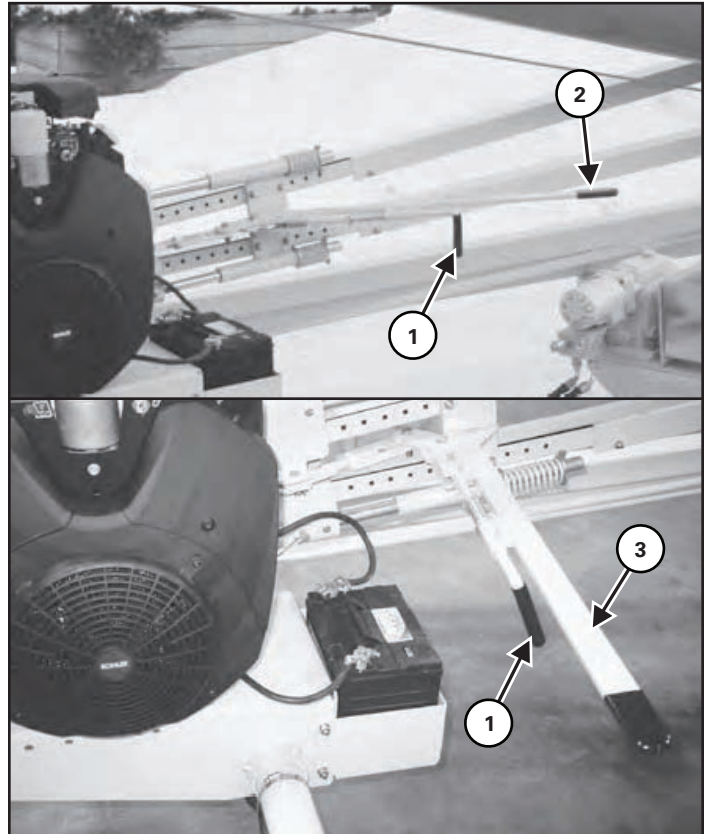

Release the lever lock (Item 1) [Figure 36].

Act on the lever to move the engine mounting platform to engage / disengage the drive system.

Move the lever (Item 2) [Figure 36] towards the engine to engage the drive system.

Move the lever (Item 3) [Figure 36] away from the engine to disengage the drive system.

Always lock the lever in either engaged or disengaged position.

	<h1 style="margin: 0;">IMPORTANT</h1>
<p>Review the engine manufacturer's operator manual for proper engine operation procedure.</p>	

MOVING AUGER

Clear the area of bystanders, especially small children, before starting.

Be sure there is enough clearance from overhead obstructions and power lines or other equipment.

Make sure all hydraulic connections are fully engaged.

Start engine on auger mover.

Figure 37

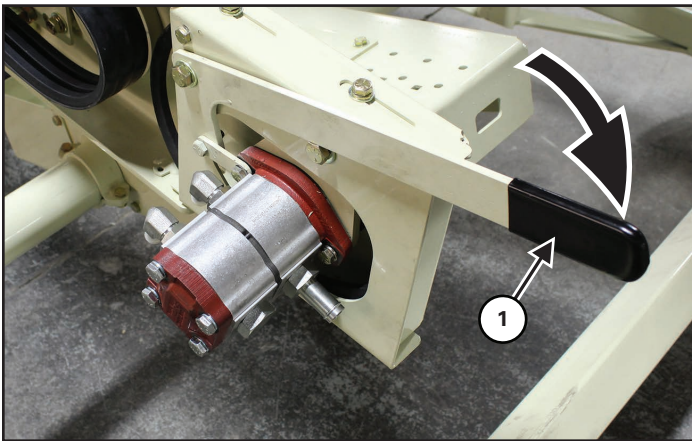

Lower the lever (Item 1) [Figure 37] to engage pump drive.

Figure 38

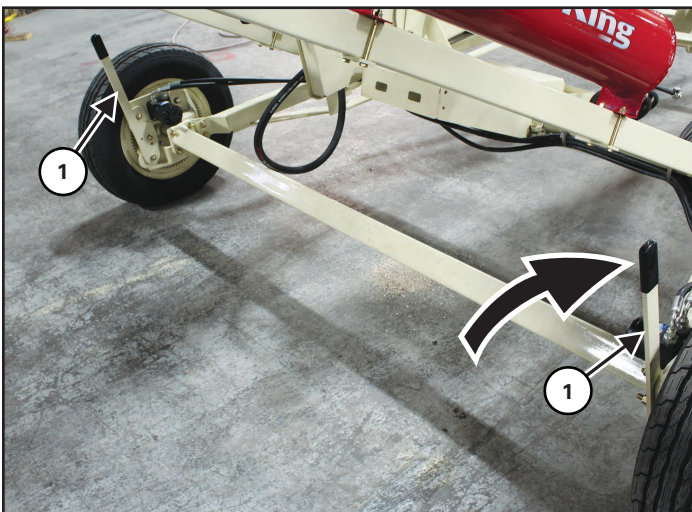

Act on the levers (Item 1) [Figure 38] at each drive wheel. Raise the levers to engage the wheel motors.

Figure 39

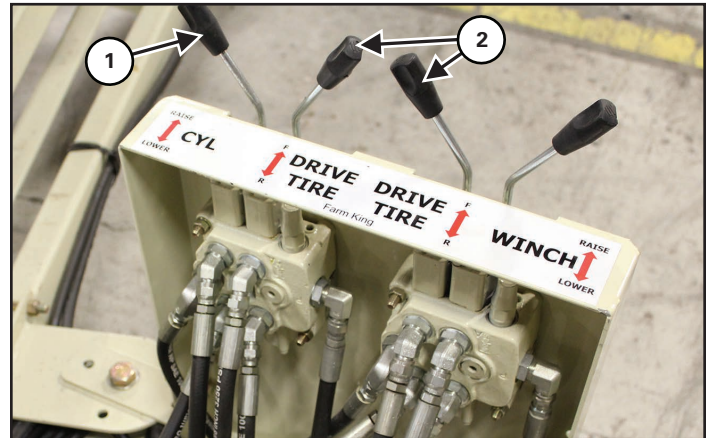

Act on the raise / lower cylinder lever (Item 1) [Figure 39] at the control console. Use the control console to raise the auger intake off the ground.

Act on the forward / reverse drive tire levers (Item 2) [Figure 39] at the control console. Use the control console to move the wheels.

	<h1>IMPORTANT</h1>
<p>Do not move the auger while in the fully raised position.</p>	

	<h1>WARNING</h1>
<p>Keep wheels of undercarriage level and on firm ground while moving the auger.</p> <p>Be aware of any obstructions in the line of travel of the auger.</p>	

RAISING / LOWERING AUGER

Clear the area of bystanders, especially small children, before starting.

Be sure there is enough clearance from overhead obstructions and power lines or other equipment.

Start engine on auger mover.

Figure 40

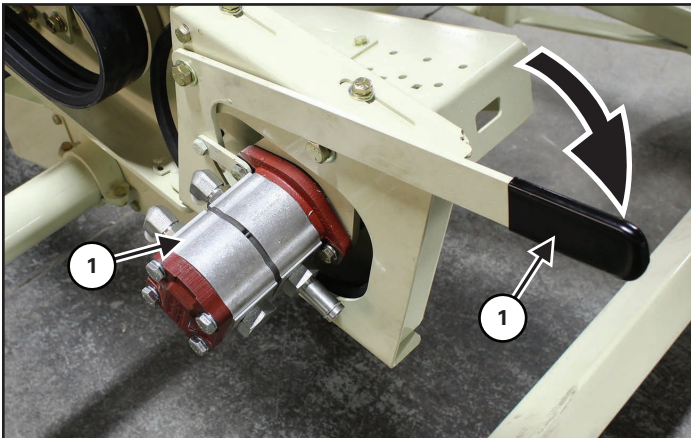

Lower the lever (Item 1) [Figure 40] to engage pump drive.

Place chocks in the front and rear of each wheel.

	<h1>IMPORTANT</h1>
<p>Do not move the auger while in the fully raised position.</p>	

Hydraulic Winch

Figure 41

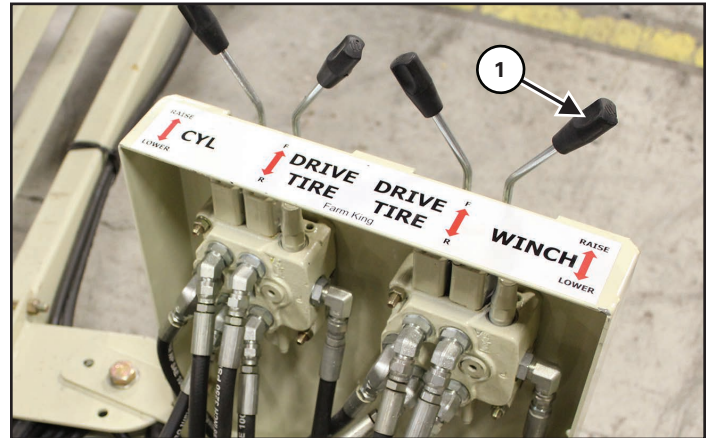

Make sure all hydraulic connections are fully engaged.

Act on the raise / lower winch lever (Item 1) [Figure 41] at the control console. Use the control console to raise the auger discharge.

	<h1>WARNING</h1>
<p>Never attempt to raise or lower the auger during operation.</p> <p>Never place blocks under the wheels to increase the elevation of auger.</p> <p>Keep wheels of undercarriage level and on firm ground.</p>	

	<h1>DANGER</h1>
<p style="text-align: center;">ELECTROCUTION HAZARD</p> <p>To prevent serious injury or death from electrocution:</p> <ul style="list-style-type: none"> • Be aware of overhead power lines. • Electrocution can occur without direct contact. 	

TRANSPORTING

Always comply with federal, state, local and provincial laws regarding the transport of farm equipment on public roadways.

!	IMPORTANT
Never exceed 20 mph (32 kph).	

!	WARNING
Use of an unapproved hitch or tractor / tow vehicle can result in loss of control, leading to serious injury or death.	
Tractor / tow vehicle and hitch must have the rated capacity to tow equipment.	

Figure 42

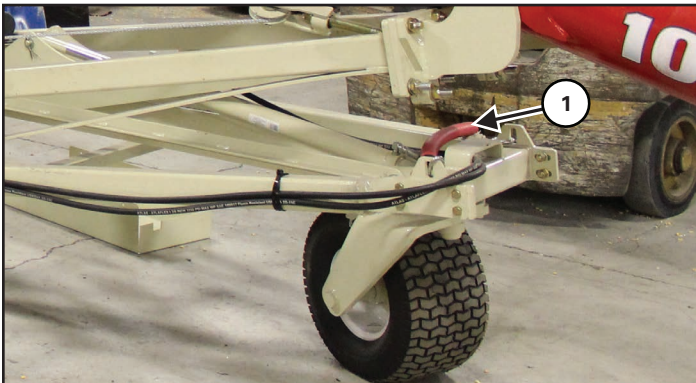

Fully raise the caster wheel off the ground (see Raising / Lowering Auger on page 41).

Secure the caster wheel to the lift frame using the transport chain (Item 1) [Figure 42].

Figure 43

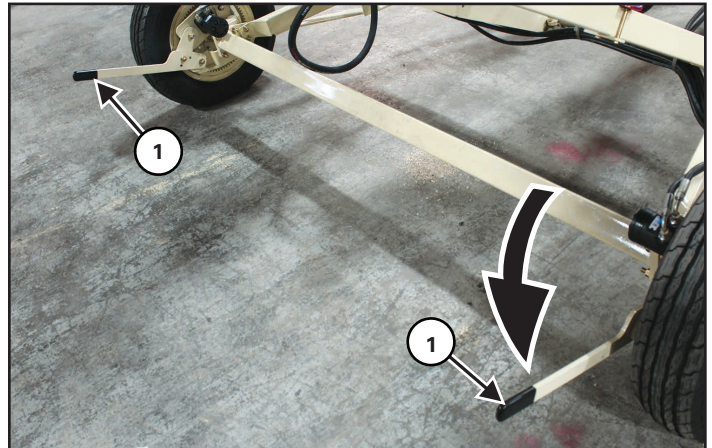

Lower both levers (Item 1) [Figure 43] for each drive wheel to disengage the motors.

!	WARNING
Make sure both drive wheels are disengaged before transporting the equipment or risk damage to hydraulic system.	

Verify that the tractor / tow vehicle is approved for transporting the equipment and that the equipment is securely attached to the tractor / tow vehicle.

Verify safety chain is installed and properly connected before transporting equipment.

Verify that the SMV (Slow Moving Vehicle) emblem, all lights and reflectors are clean and visible.

	<h1 style="margin: 0;">WARNING</h1>
<p>AVOID SERIOUS INJURY OR DEATH</p> <p>DO NOT transport loaded equipment on public roadways. Excess weight will greatly increase tractor stopping distance and may cause the operator to lose control of the tractor or tow vehicle.</p>	

The ratio of the tractor / tow vehicle weight to the loaded equipment weight plays an important role in defining acceptable travel speed.

TRAVEL SPEED - Acceptable travel speed.

WEIGHT RATIO - Weight of fully equipped or loaded implement(s) relative to weight of tractor / tow vehicle.

Maximum Travel Speed	Weight Ratio
20 mph (32 kph)	Less than 1 to 1
10 mph (16 kph)	Less than 2 to 1
DO NOT TOW	More than 2 to 1

Farm King



MAINTENANCE

TROUBLESHOOTING.....	47
Chart.....	47
SERVICE SCHEDULE.....	48
Maintenance Intervals.....	48
LUBRICATION.....	49
Recommendations.....	49
HYDRAULIC PUMP BELTTENSION / ALIGNMENT.....	49
HYDRAULIC WINCH GEARBOX.....	50
HYDRAULIC OIL FILTER.....	50
AXLES.....	51
Wheel Nut Torque.....	51
Tire / Wheel Replacement.....	51
Tire Pressure.....	52
SAFETY SIGN (DECAL) INSTALLATION.....	52
STORAGE AND RETURN TO SERVICE.....	53
Storage.....	53
Return To Service.....	53

Farm King



TROUBLESHOOTING

Chart

	<h1>WARNING</h1>
<p>Instructions are necessary before operating or servicing equipment. Read and understand the Operator And Parts Manual and safety signs (decals) on equipment. Follow warnings and instructions in the manuals when making repairs, adjustments or servicing. Check for correct function after adjustments, repairs or service. Untrained operators and failure to follow instructions can cause injury or death.</p>	

NOTE: If a problem is encountered that is difficult to solve, even after having read through this troubleshooting section, please call your local Farm King dealer. Before you call, please have this Operator And Parts Manual and the serial number of your machine at hand.

PROBLEM	CAUSE	CORRECTION
No mover functions can be used.	No power.	Start engine and engage pump.
	Drive belt slipping.	Adjust drive belt tension.
	Plugged filter.	Change oil filter.
	Low oil level.	Add oil to reservoir.
Wheel(s) don't move.	Wheel drive linkage not engaged.	Engage wheel drive.
	Drive gears don't mesh.	Adjust linkage to allow gears to mesh.
Intake digs into ground.	Front wheel does not lower.	Anchor chain still in place.

SERVICE SCHEDULE

Maintenance Intervals

Maintenance work must be done at regular intervals. Failure to do so will result in excessive wear and early failures. The service schedule is a guide for correct maintenance of the equipment.

	WARNING
---	---------

Instructions are necessary before operating or servicing equipment. Read and understand the Operator and Parts Manual and safety signs (decals) on equipment. Follow warnings and instructions in the manuals when making repairs, adjustments or servicing. Check for correct function after adjustments, repairs or service. Untrained operators and failure to follow instructions can cause injury or death.

#	DESCRIPTION	SERVICE PROCEDURES					
		Check	Clean	Lube	Change	Cover	Repack
Weekly (or every 50 hours)							
1	Pump Drive Belt Tension	•					
Every 100 hours							
2	Hydraulic Winch Gearbox	•					
Annually (or every 400 hours)							
3	Wheel Bearings						•
4	Machine		•				
Two Years (or every 400 hours)							
5	Gearbox Oil (Hydraulic Winch)				•		
6	Hydraulic System Oil Filter				•		

LUBRICATION

Recommendations

Always use a good quality multi-purpose / lithium base grease when lubricating the equipment.

- Always use a hand-held grease gun.
- Clean fitting before greasing, to avoid injecting dirt and grit.
- Replace and repair broken fittings immediately.
- If fittings will not take grease, remove and clean thoroughly. Replace fitting if necessary.



IMPORTANT

Fluid such as engine oil, hydraulic fluid, coolants, grease, etc. must be disposed of in an environmentally safe manner. Some regulations require that certain spills and leaks on the ground must be cleaned in a specific manner. See local, state and federal regulations for the correct disposal.

HYDRAULIC PUMP BELT TENSION / ALIGNMENT

Figure 44

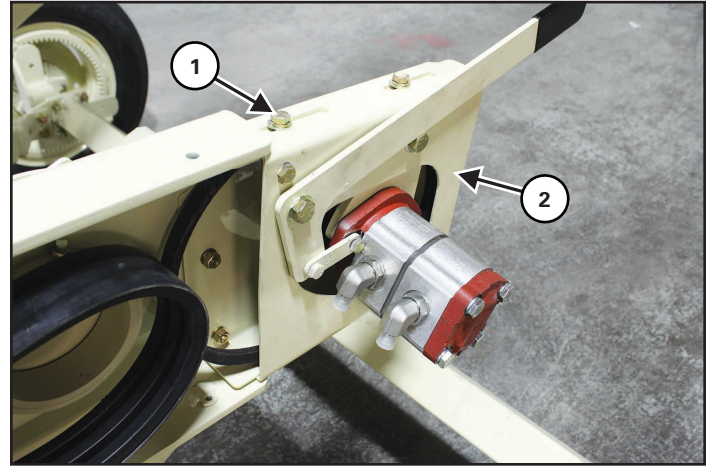

Loosen the four 3/8" x 1" hex bolts (Item 1) [Figure 44] from the hydraulic pump mounting bracket.

Move the bracket (Item 2) [Figure 42] forward or backward to slightly adjust tension on the belt.

Tighten the bracket hardware.

HYDRAULIC WINCH GEARBOX

Figure 45

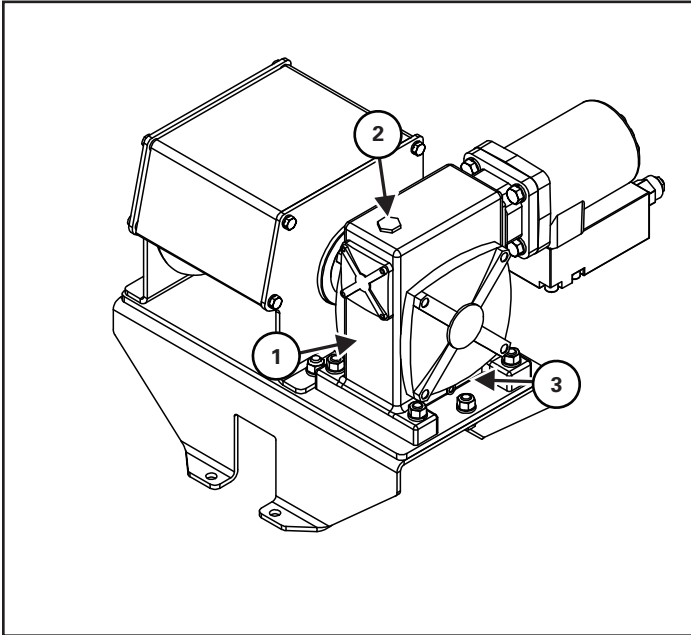

Check the oil level by removing the level plug (Item 1) [Figure 45]. The oil should just fill the threads of level plug.

Fill the gearbox by removing the fill plug (Item 2) [Figure 45]. Add oil as required.

Use SAE 85W140 gear oil or equivalent.

Drain oil from the gearbox by removing the drain plug (Item 3) [Figure 45]. Make sure the breather is open.

Reinstall and tighten all plugs when finished.

HYDRAULIC OIL FILTER

Figure 46

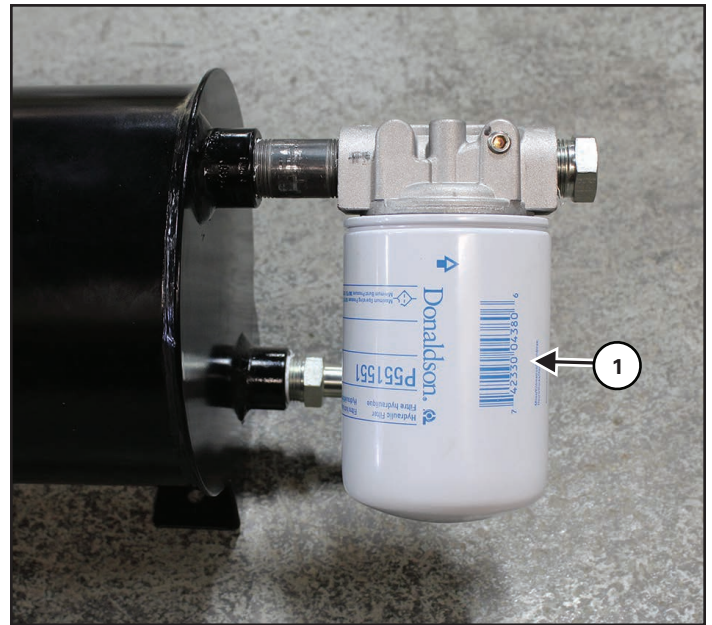

Replace the oil filter (Item 1) [Figure 46].

Apply a light film of oil to the o-ring on the new filter. Hand tighten the new filter.

Run the hydraulic system for 1- 2 minutes and check for leaks around the filter.

Tighten the filter slightly to stop any leaks.

Check hydraulic system oil level. Top up as required.



IMPORTANT

Fluid such as engine oil, hydraulic fluid, coolants, grease, etc. must be disposed of in an environmentally safe manner. Some regulations require that certain spills and leaks on the ground must be cleaned in a specific manner. See local, state and federal regulations for the correct disposal.

AXLES

Wheel Nut Torque

!	IMPORTANT
Check Wheel Nuts After:	
<ol style="list-style-type: none"> 1. First 3 (three) hours of field operation. 2. First 10 (ten) hours of field operation. 3. First 50 (fifty) hours of field operation. 4. Every 200 (two hundred) hours of operation. 	
REPEAT PROCEDURE IF A WHEEL IS REMOVED OR REINSTALLED	

Tighten wheel bolts to proper torque.

Tire / Wheel Replacement

Periodically check tires for cuts, bulges and damaged rims.

!	WARNING
AVOID INJURY OR DEATH	
Before you leave the operator's position:	
<ul style="list-style-type: none"> • Always park on a flat level surface. • Place all controls in NEUTRAL. • Engage the park brake. • Stop the engine and remove the key. • Wait for all moving parts to stop. 	

Park the tractor / equipment on a flat level surface.

Place all controls in neutral, engage the park brake, stop the engine and wait for all moving parts to stop. Leave the operator's position.

!	WARNING
AVOID INJURY OR DEATH	
Always chock tires before performing any maintenance or service.	

Place chock blocks behind and in front of the opposite tire to be removed.

Raise axle frame with jack until the tire / wheel is slightly off the ground.

NOTE: Place blocks / stands under the frame to secure the equipment when tire / wheel is raised off the ground.

Remove the five wheel nuts and tire assembly.

Figure 47

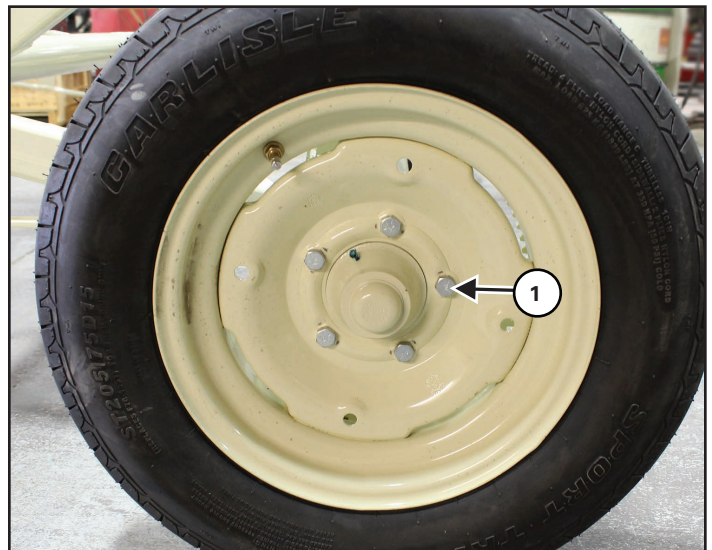

Install the new tire with the valve stem facing out.

Reinstall five wheel bolts (Items 1) [Figure 47]. Tighten wheel bolts in a criss-cross pattern.

Torque wheel bolts to 72 ft-lbs.

Lower tire / wheel assembly to the ground.

After tightening the wheel bolts, pull the equipment approximately one (1) mile and re-tighten the wheel bolts to proper torque.

Tire Pressure

	CAUTION
	
<p>When inflating tires, use a clip-on chuck and extension hose long enough to allow you to stand to one side and NOT in front of or over the tire assembly.</p>	

Check tire pressure daily. Fill tires per tire manufacturer's recommendation. See side wall of tire for inflation requirements.

SAFETY SIGN (DECAL) INSTALLATION

	IMPORTANT
<p>When replacing safety signs (decals), the temperature must be above 10° C (50° F).</p>	

- Remove all portions of the damaged safety sign (decal).
- Thoroughly clean the area with adhesive remover and glass cleaner. Remove all adhesive residue.
- Allow the area to dry completely before installing the new safety sign (decal).
- Position the safety sign (decal) in the correct location.
- Remove a small portion of the backing paper on the safety sign (decal).
- Press on the safety sign (decal) where the backing paper has been removed.
- Slowly remove the remaining backing paper, pressing on the safety sign (decal) as the backing paper is removed.
- Using the backing paper, pressing firmly, move the backing paper over the entire safety sign (decal) area.

Note: Small air pockets can be pierced with a pin and smoothed out using the piece of the backing paper.

STORAGE AND RETURN TO SERVICE

Storage

Sometimes it may be necessary to store the equipment for an extended period of time. Below is a list of items to perform before storage.



- Thoroughly wash the machine with a pressure washer or water hose to remove all dirt, mud, debris or residue.
- Lubricate all bushings to remove any water residue from washing.
- Remove any material that has become entangled around any moving part.
- Inspect the hitch and all welds on the equipment for wear and damage.
- Check for loose hardware, missing guards, or damaged parts.
- Check for damaged or missing safety signs (decals). Replace if necessary.
- Replace worn or damaged parts.
- Touch up all paint nicks and scratches to prevent rusting.
- Place the equipment in a dry protected shelter.

Note: If a dry protected shelter is not available, cover with a waterproof tarp and tie down securely.

- Place the equipment flat on the ground.

Return To Service

After the equipment has been in storage, it is necessary to follow a list of items to return the equipment to service.

- Be sure all shields and guards are in place.
- Lubricate the equipment.

- Connect to a tractor and operate equipment, verify all functions operate correctly.
- Check for leaks. Repair as needed.

Farm King



PARTS IDENTIFICATION

GENERAL PARTS INFORMATION.....	56
MOVER LIFT FRAME	56
MOVER SCISSOR LIFT.....	58
WHEEL HYDRAULIC MOTOR ASSEMBLY.....	60
BELT DRIVE HYDRAULIC MOTOR.....	62
OIL TANK.....	64
BELT GUIDE.....	66
CONTROL CONSOLE.....	68
CASTOR WHEEL / PIVOT SHAFT.....	70
HYDRAULIC HOSES.....	72

GENERAL PARTS INFORMATION

The parts identification section list descriptions, part numbers and quantities for all North America Base Model CX2 series augers. Contact your Farm King dealer for additional parts information.

MOVER LIFT FRAME

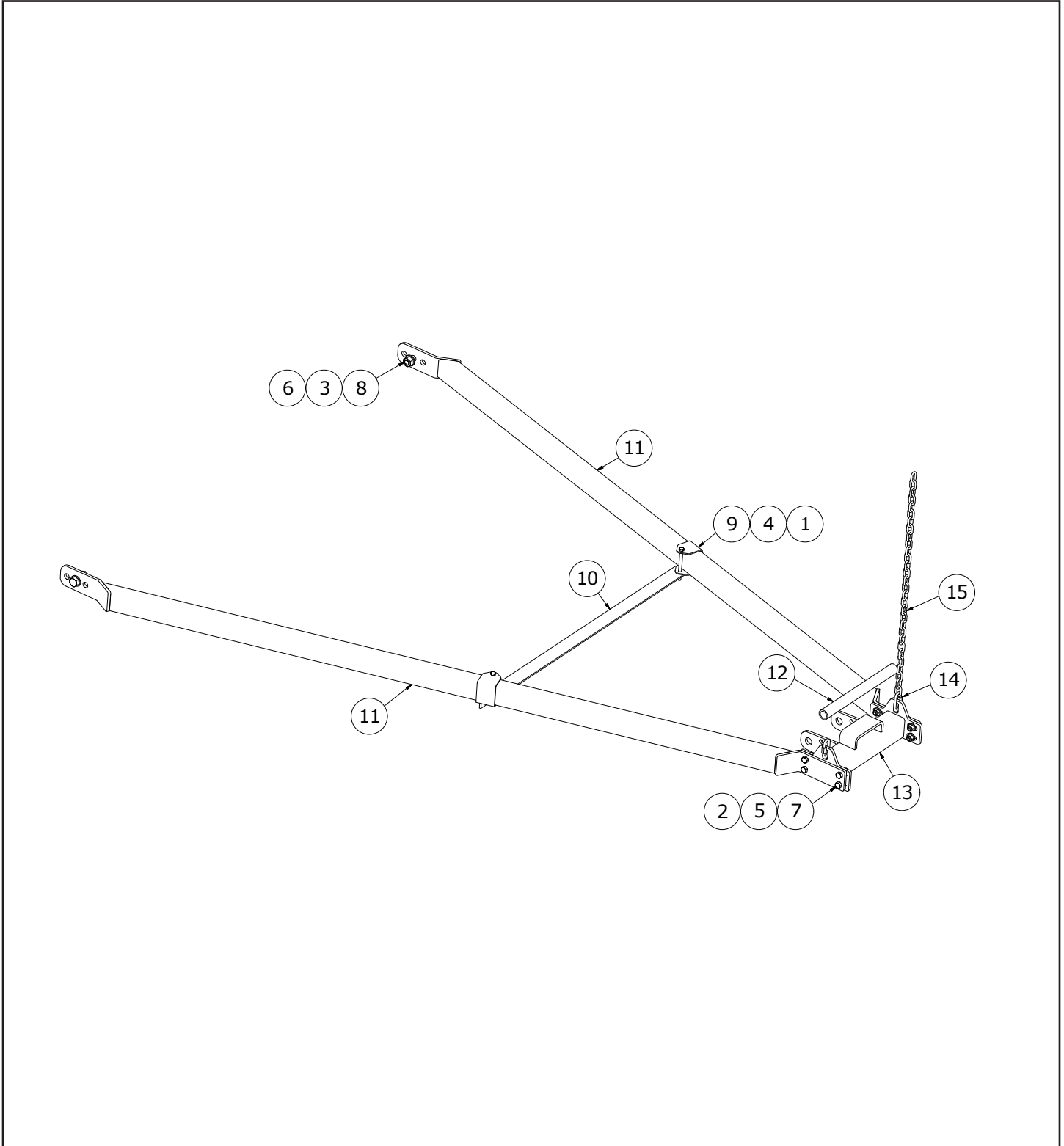

ITEM	PART NUMBER	DESCRIPTION	QTY.
1	812363	3/8" LOCK NUT (PL)	2
2	812364	1/2" LOCK NUT (PL)	8
3	812365	3/4" LOCK NUT (PL)	2
4	81588	3/8" X 4 1/2" HEX BOLT (PL)	2
5	84048	1/2" SAE FLAT WASHER (PL)	8
6	84050	3/4" S.A.E. FLAT WASHER (PL)	4
7	84277	1/2" X 1 1/2" HEX BOLT (PL)	8
8	84467	3/4" X 2" HEX BOLT (PL)	2
9	912443	CROSS BRACE CLAMP	2
10	913275	ANGLE-MOVER ARM REST	1
11	913598	WELDT-MOVER 41 FT	2
	913498	WELDT-MOVER 51 FT	2
	913643	WELDT-MOVER 61 FT	2
12	913729	HOSE-1.0 ID X 15	1
13	924022	WELDT-MOVER FRONT	1
14	960167	QUICK LINK (PL)	2
15	929411	CHAIN - PLATED	1

MOVER SCISSOR LIFT

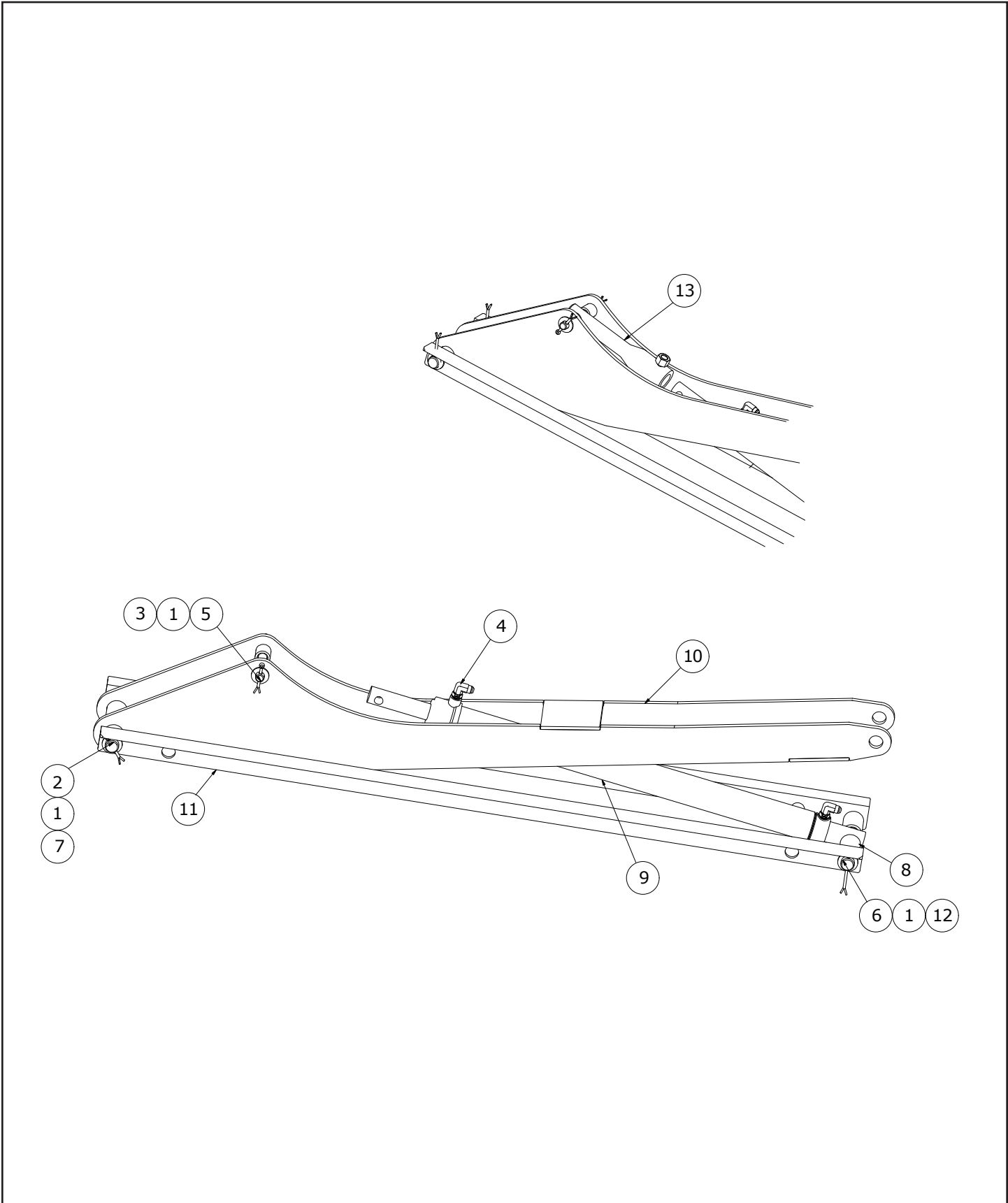

ITEM	PART NUMBER	DESCRIPTION	QTY.
1	81207	3/16" X 2" COTTER PIN (BR)	6
2	967140	1" X 10GA NARROW RIM WASH (PL)	2
3	812639	WASHER 0.625 SAE FLAT BS PL	2
4	910262	FTG-6MORBX-6MJIC 90 DEG ELBOW	2
5	913300	PIN-0.625X5.51	1
6	913312	PIN-1.00X8.82	2
7	913312	PIN-1.00X8.82	2
8	913313	SPACER-1.02	2
9	916438	CYLINDER-2.00" DIA, 36.75 TO 63.25	1
10	927228	WELDT-LIFTING ARM CA MOVER	1
11	928777	MOVER LOWER LIFT ARM - 41 FT., 51 FT.	2
	928883	MOVER LOWER LIFT ARM - 61 FT.	2
12	967140	1" X 10GA NARROW RIM WASH (PL)	2
13	927283	CYLINDER STROKE EXTENDER - 61 FT.	1

WHEEL HYDRAULIC MOTOR ASSEMBLY

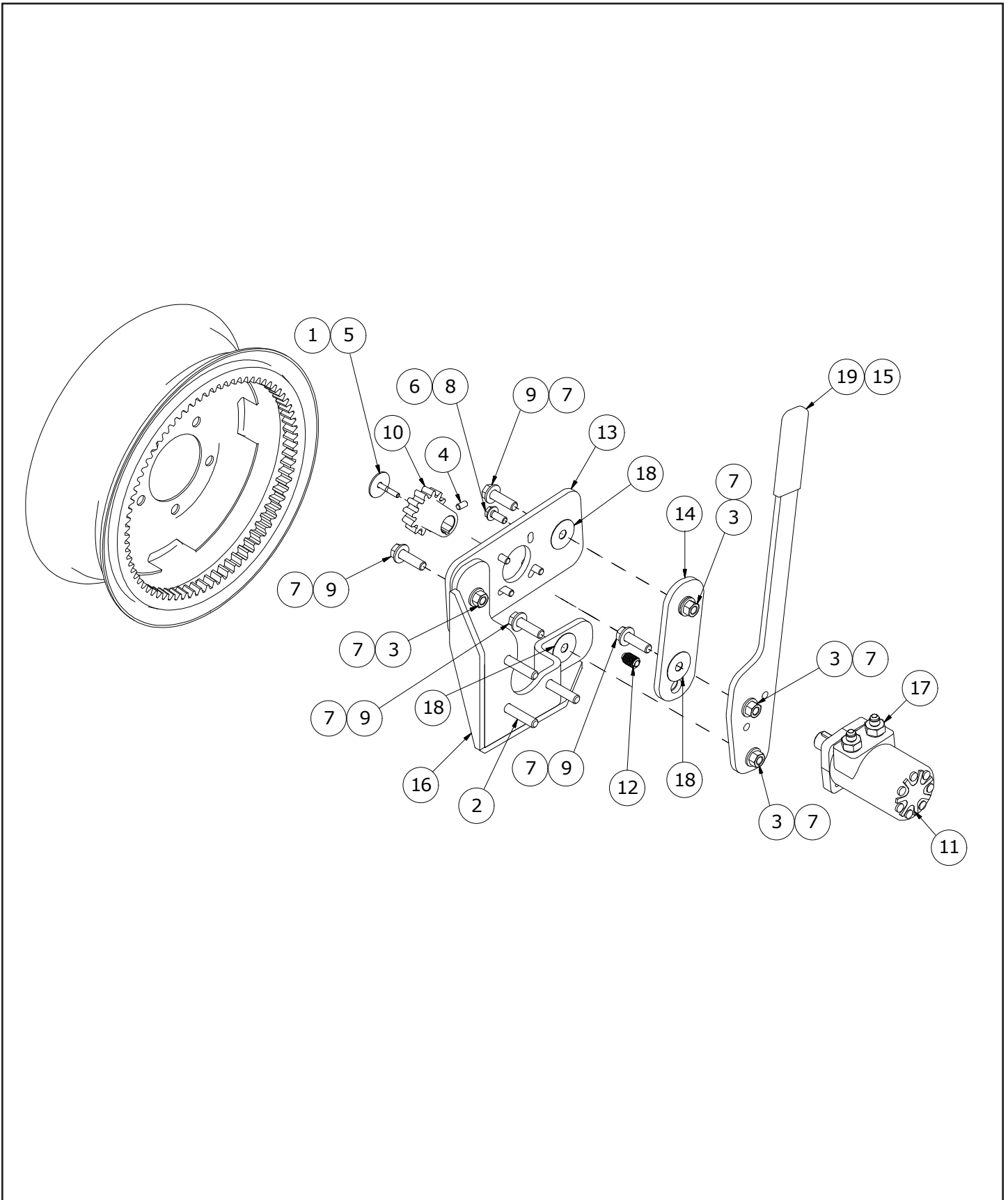

ITEM	PART NUMBER	DESCRIPTION	QTY.
1	811631	1/4" X 1 1/2" HEX BOLT GR5 (PL)	1
2	811796	1/2" X 2 1/2" HEX BOLT GR5 (PL)	3
3	812364	1/2" LOCK NUT (PL)	4
4	813544	SETSCREW, SOCKET SER. 5/16" X 1/2"	1
5	813748	WASHER, FENDER, 1 1/2"OD X 5/16"ID (PL)	1
6	84039	WASHER - 3/8" SAE FLAT (PL)	4
7	84048	1/2" SAE FLAT WASHER (PL)	9
8	86170	3/8" X 1" HEX BOLT GR.5 (PL)	4
9	87553	1/2" X 1.75" HEX BOLT UNC GR5 (PL)	4
10	910204	GEAR-PINION, MOVER	1
11	910245	HYD MOTOR EATON 101-1011-009	1
12	913158	PLUNGER-5/8 BALL NOSE SPRING	1
13	913319L	PLATE-HYD MOTOR	1
14	913321	WELDT-HYD MOTOR LINK	1
15	913322L	PLATE-MOVER ENGAGE	1
16	913325	WELDT-HYD MOTOR MOUNT	1
17	913557	ADAPTER-10 MORB X -6 MJIC	2
18	913747L	SPACER-0.53 ID X 1.75 OD X 20 GA	3
19	JDCW25634	RUBBER GRIP	1

BELT DRIVE HYDRAULIC MOTOR

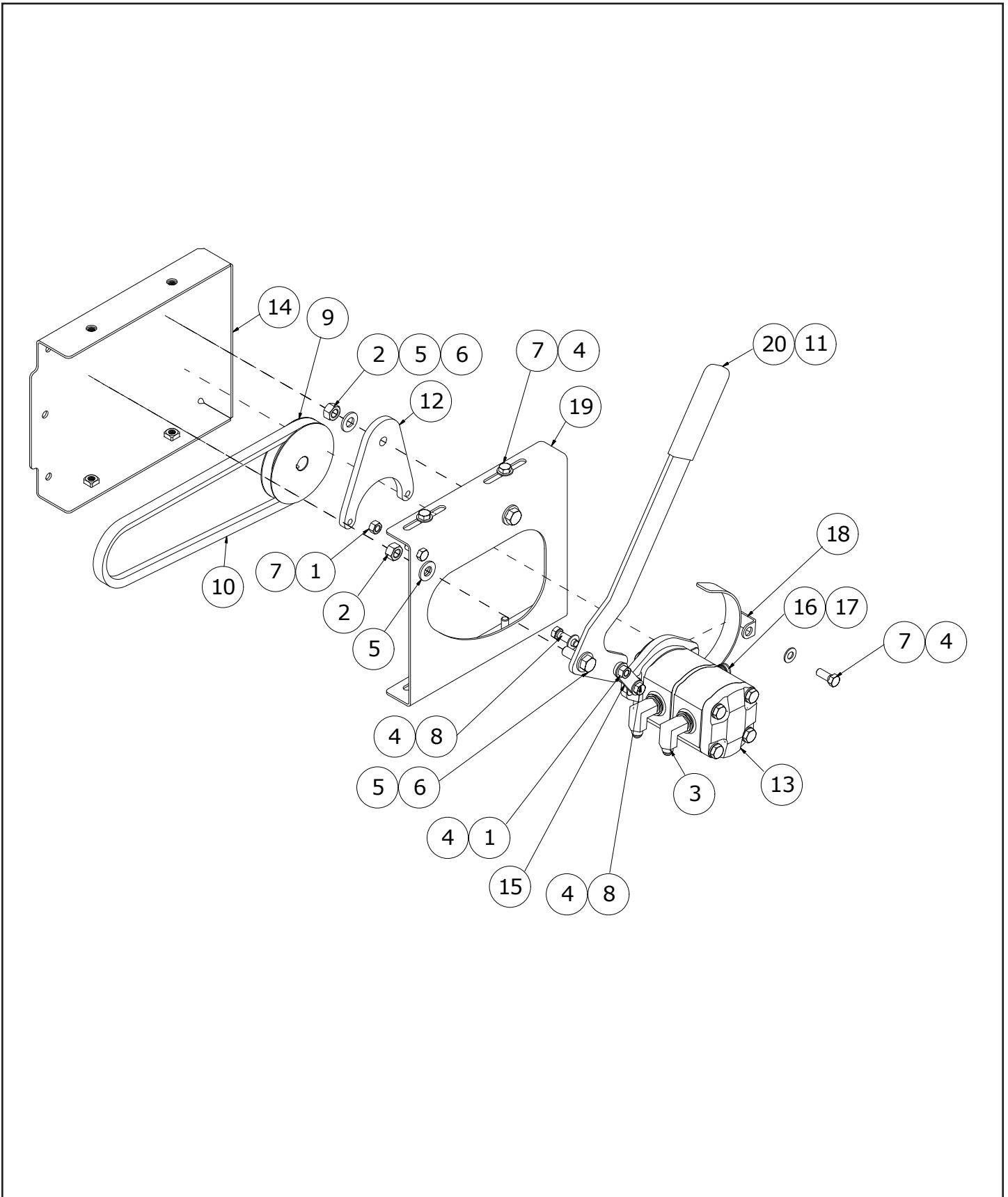

ITEM	PART NUMBER	DESCRIPTION	QTY.
1	812363	3/8" LOCK NUT (PL)	2
2	812364	1/2" LOCK NUT (PL)	2
3	812457	ELBOW-10 MORB X -6 MJIC, 90 DEG	2
4	84039	WASHER - 3/8" SAE FLAT (PL)	8
5	84048	1/2" SAE FLAT WASHER (PL)	4
6	84277	1/2" X 1 1/2" HEX BOLT (PL)	2
7	86170	3/8" X 1" HEX BOLT GR.5 (PL)	6
8	86171	3/8" X 1 1/4" HEX BOLT (PL)	2
9	910199	SGL GRV 4 1/2" SHEAVE	1
10	910263	BELT B-35	1
11	913184	PLATE-HYD PUMP HANDLE	1
12	913186	PLATE-HYD PUMP ARM	1
13	913444	PUMP-GEARTANDEM SALAMI	1
14	913514	WELDT-HYD PUMP MOUNT CA MOVER	1
15	913520L	PLATE-HYD LINK CA MOVER	1
16	913547	ADAPTER-12 MORB X -12 BARB	1
17	914759	PLUG-12 MORB HEX HEAD	1
18	924394	WELDT-MOVER BELT GUIDE	1
19	924415	BRKT-HYD PUMP MOUNT	1
20	JDCW25634	RUBBER GRIP	1

OIL TANK

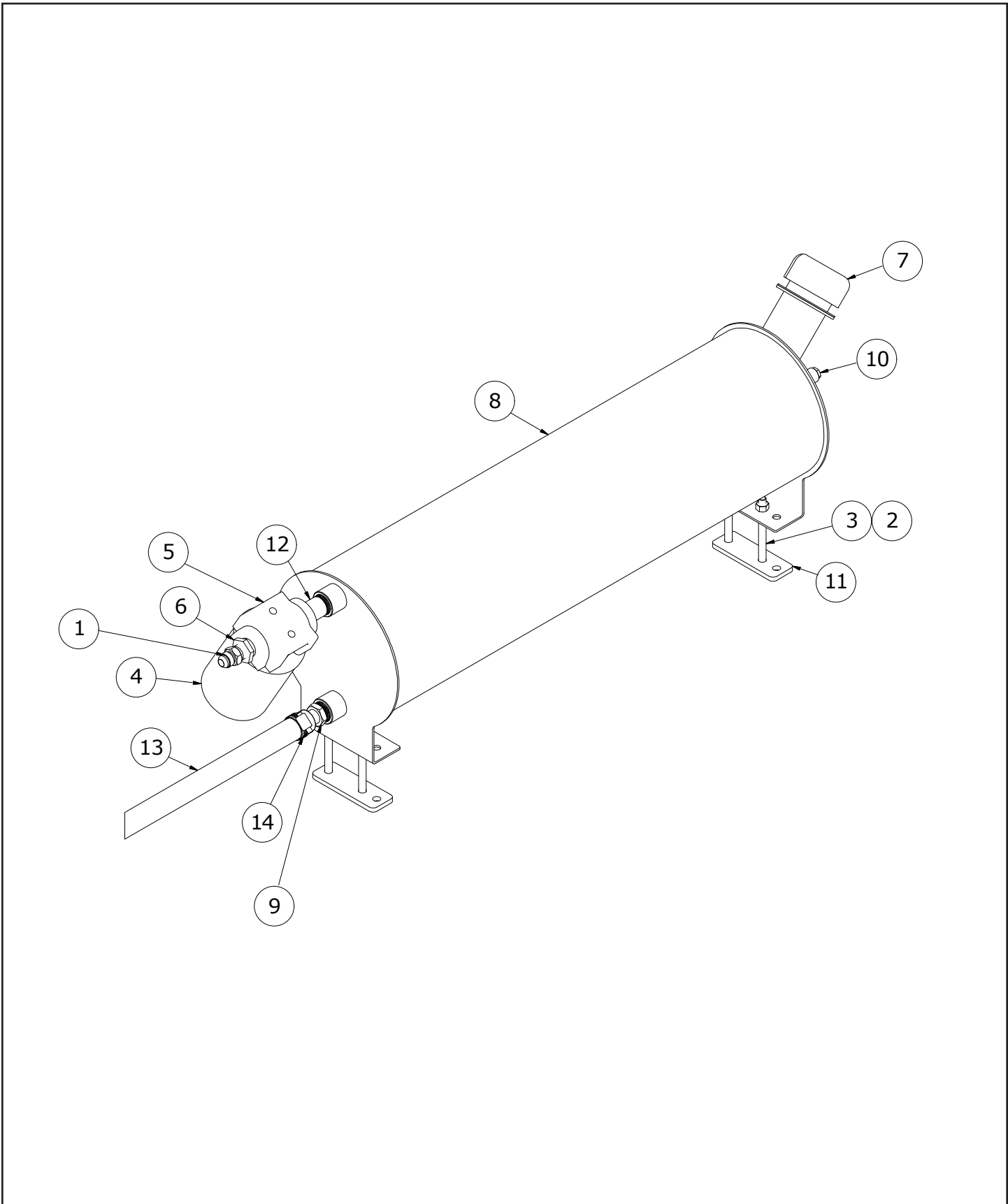

ITEM	PART NUMBER	DESCRIPTION	QTY.
1	811422	ADAPTER - 1/2 MNPT X 3/4 MJIC	1
2	812363	3/8" LOCK NUT (PL)	4
3	81587	3/8" X 4" HEX BOLT (PL)	4
4	910202	10 MICRON OIL FILTER	1
5	910212	FILTER HEAD	1
6	910442	REDUCER, 3/4"MNPT X 1/2"FNPT	1
7	913565	FILL CAP-3.14", TANK	1
8	913568	WELDT-TANK CA	1
9	913571	ADAPTER-12 MPT X -12 HOSE BARB	1
10	913582	PLUG-4 MPT HEX	1
11	913590L	PLATE-TANK MOUNT	2
12	913695	NIPPLE-12 MPT X 2.5"	1
13	913758	HOSE-12 SUCTION	1
14	914220	CLAMP-BAND HOSE, .563" - 1.25"	2

BELT GUIDE

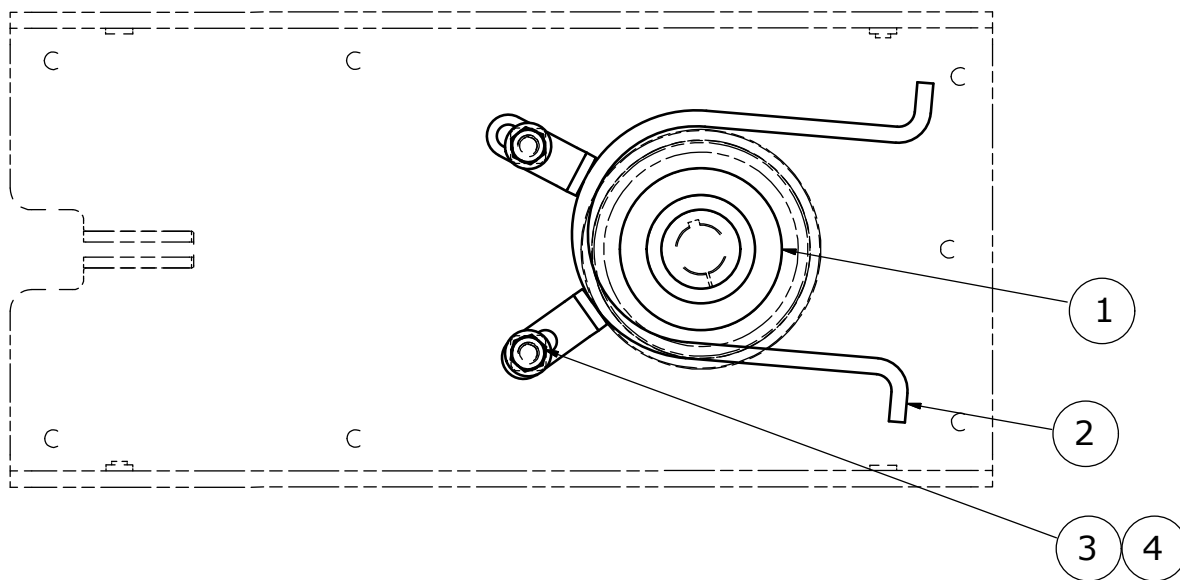

ITEM	PART NUMBER	DESCRIPTION	QTY.
1	913591	SHEAVE-2B34 - 841	1
	913592	SHEAVE-3B34 - 851	1
	912848	SHEAVE-4B34 - 1041, 1051, 1061	1
	912850	SHEAVE BUSHING-SDX1-1/8 - 1041, 1051, 1061	1
2	924396	WELDT-MOVER BELT GUIDE	1
3	81619	1/2" X 1" HEX BOLT (PL)	2
4	84048	1/2" SAE FLAT WASHER (PL)	2

CONTROL CONSOLE

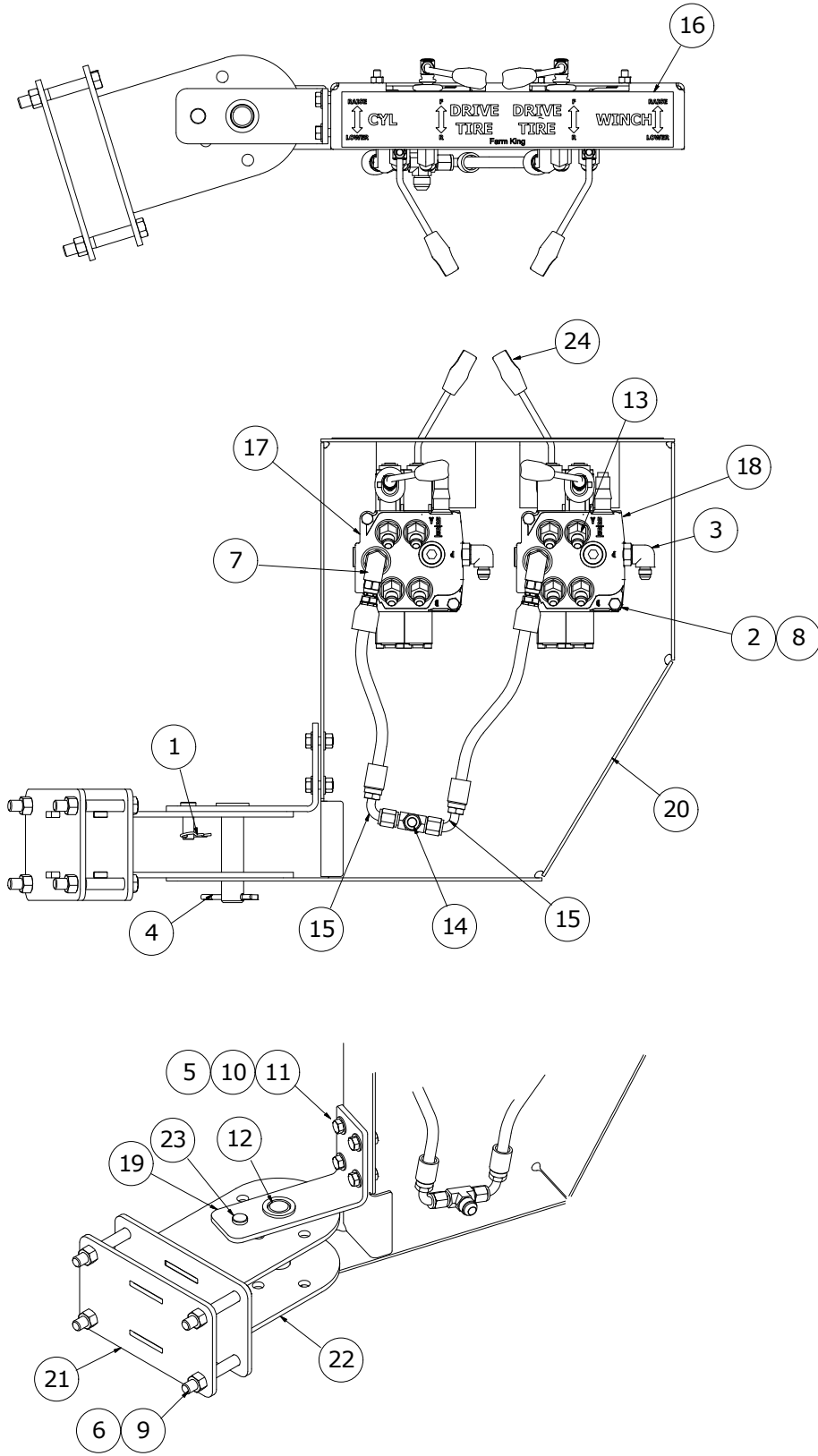

ITEM	PART NUMBER	DESCRIPTION	QTY.
1	12780	#7 HAIR PIN CLIP	1
2	810761	5/16" X 2 1/2" HEX BOLT (PL)	4
3	811916	ELBOW-8MORB X -6MJIC 90DEG	2
4	81210	1/4" X 2" COTTER PIN (PL)	1
5	812363	3/8" LOCK NUT (PL)	4
6	812364	1/2" LOCK NUT (PL)	4
7	812457	ELBOW-10 MORB X -6 MJIC, 90 DEG	2
8	81568	5/16" HEX NUT (PL)	4
9	81629	1/2" X 3 1/2" HEX BOLT (PL)	4
10	84039	WASHER - 3/8" SAE FLAT (PL)	8
11	86170	3/8" X 1" HEX BOLT GR.5 (PL)	4
12	900705	PIN WELDMENT 1.000" DIA	1
13	913534	ELBOW-45 DEG -8 MORB X -6 MJIC	8
14	913716	TEE-8 MJIC X -6 MJIC X -6 MJIC	1
15	913967	HOSE-6 X -6JIC X -6JIC 90 ELBOW	2
16	927252	DECAL-CONSOLE CA MOVER	1
17	913495	VALVE-2 SPOOL, MOTOR AND CYLINDER	1
18	913482	VALVE-2 SPOOL, WINCH AND MOTOR	1
19	928706	SUPPORT PLATE-HYD CONSOLE	1
20	928707	CONSOLE-CA MOVER	1
21	928888	PLATE-CONSOLE MOUNT CA MOVER	1
22	928890	WELDT-CONSOLE PIVOT CA MOVER	1
23	961876	1/2" X 1 1/2" CLEV PIN (PL)	1
24	919367	HANDLE-SHAFT W/THREADED END	4

CASTOR WHEEL / PIVOT SHAFT

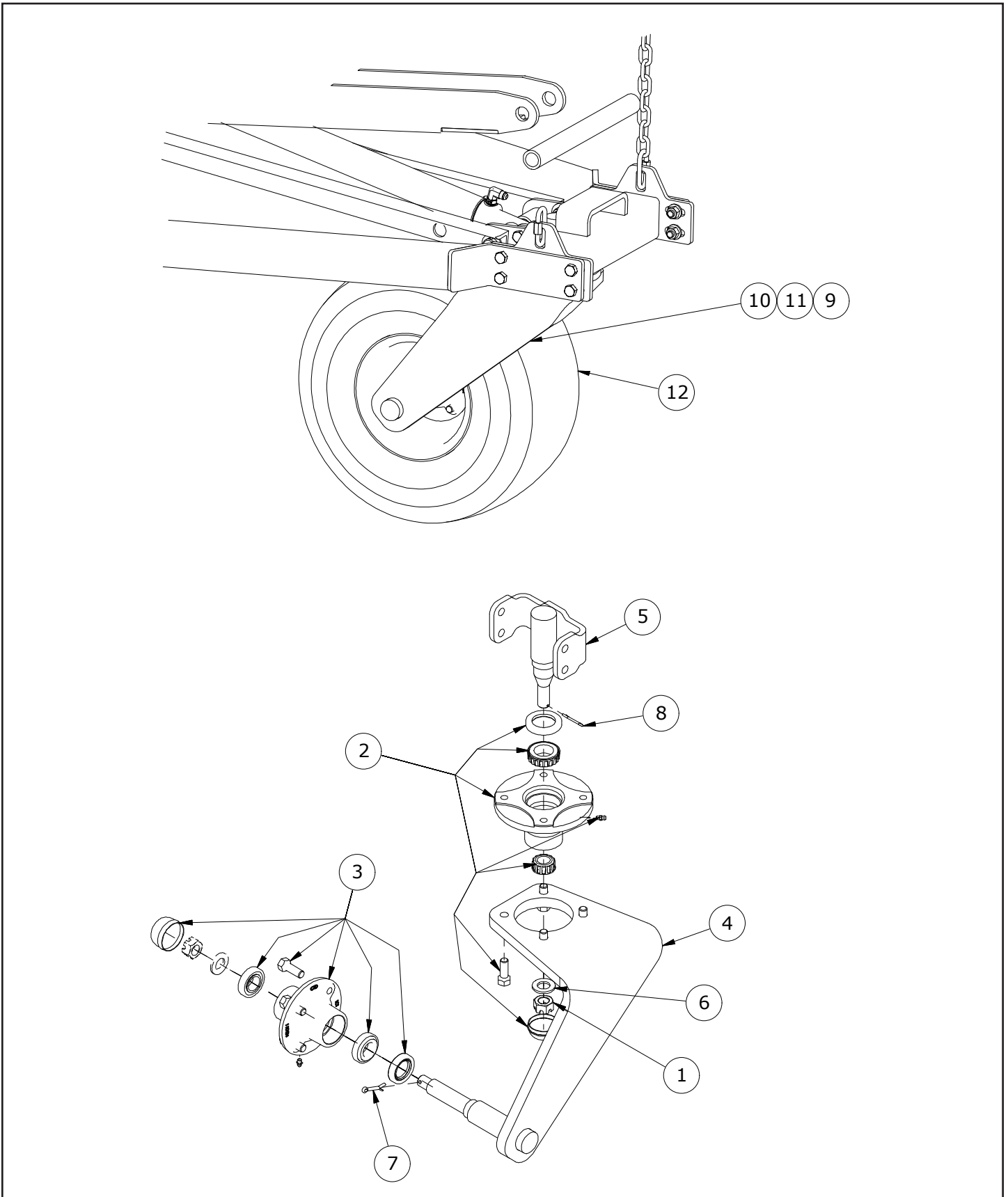

ITEM	PART NUMBER	DESCRIPTION	QTY.
1	81834	3/4" SLOTTED HEX NUT	1
2	9105173	HUB CTD H411 COMPLETE ASSY	1
3	913148	HUB-4 ON 4	1
4	913170	WELDT-CASTOR	1
5	924024	WELDT-MOVER PIVOT STUB	1
6	9812416	3/4" FLAT WASHER (BR)	1
7	9812433	3/16" X 1 1/2" COTTER PIN	1
8	9812486	1/8" X 1 1/2" COTTER PIN (BR)	1
9	924126	ASSY-MOVER PIVOT CASTOR	1
10	84277	1/2" X 1 1/2" HEX BOLT (PL)	4
11	812364	1/2" LOCK NUT (PL)	4
12	913561	ASSY-18X9.5-8 TIRE WITH RIM	1
	913082	TIRE-18X9.50-8	1
	913318	WHEEL-4 X 4 BOLT	1
	913746	TIRE VALVE-TR413	1

HYDRAULIC HOSES

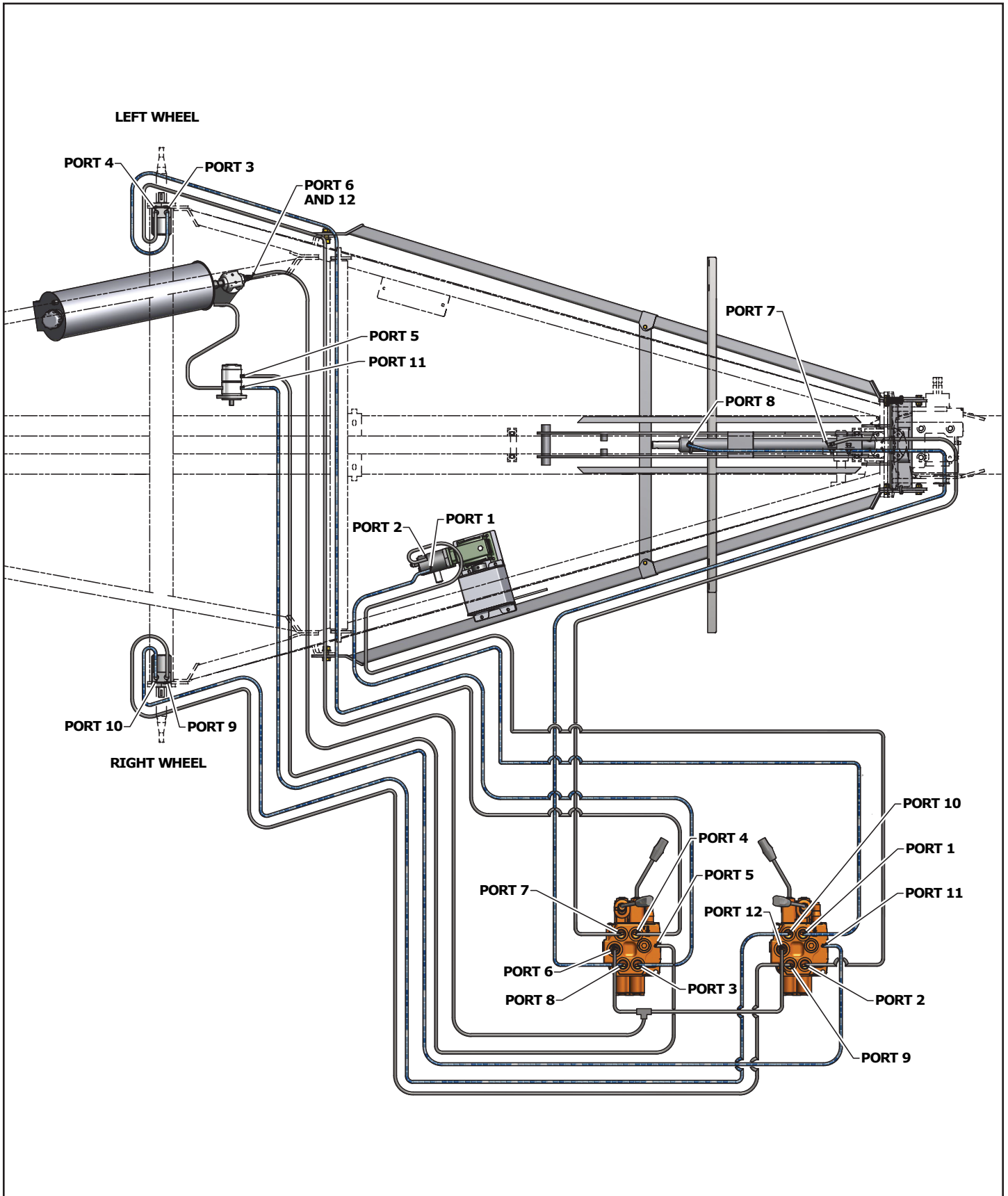

PORT	PART NUMBER	DESCRIPTION	QTY.
41 FT. MODELS			
1	913654	HOSE-6 X -6JIC X -6JIC 90 ELBOW - 117"	1
2	913654	HOSE-6 X -6JIC X -6JIC 90 ELBOW - 117"	1
3	913651	HOSE-6 X -6JIC X -6JIC 90 ELBOW - 159"	1
4	913651	HOSE-6 X -6JIC X -6JIC 90 ELBOW - 159"	1
5	913655	HOSE-6 X -6JIC X -6JIC - 123"	1
6	913656	HOSE-8 X -8JIC X -8JIC - 139.5"	1
7	913852	HOSE-6 X -6JIC X -6JIC - 134"	1
8	913853	HOSE-6 X -6JIC X -6JIC - 163"	1
9	913650	HOSE-6 X -6JIC X -6JIC 90 ELBOW - 83"	1
10	913650	HOSE-6 X -6JIC X -6JIC 90 ELBOW - 83"	1
11	913655	HOSE-6 X -6JIC X -6JIC - 123"	1
12	913656	HOSE-8 X -8JIC X -8JIC - 139.5"	1
51 FT. MODELS			
1	913554	HOSE-6 X -6JIC X -6JIC 90 ELBOW - 115"	1
2	913554	HOSE-6 X -6JIC X -6JIC 90 ELBOW - 115"	1
3	913551	HOSE-6 X -6JIC X -6JIC 90 ELBOW - 195"	1
4	913551	HOSE-6 X -6JIC X -6JIC 90 ELBOW - 195"	1
5	913555	HOSE-6 X -6JIC X -6JIC - 139"	1
6	913556	HOSE-8 X -8JIC X -8JIC - 161.25"	1
7	913552	HOSE-6 X -6JIC X -6JIC - 156"	1
8	913553	HOSE-6 X -6JIC X -6JIC - 189"	1
9	913550	HOSE-6 X -6JIC X -6JIC 90 ELBOW - 93"	1
10	913550	HOSE-6 X -6JIC X -6JIC 90 ELBOW - 93"	1
11	913555	HOSE-6 X -6JIC X -6JIC - 139"	1
12	913556	HOSE-8 X -8JIC X -6JIC - 161.25"	1
61 FT. MODELS			
1	913754	HOSE-6 X -6JIC X -6JIC 90 ELBOW - 127"	1
2	913754	HOSE-6 X -6JIC X -6JIC 90 ELBOW - 127"	1
3	913751	HOSE-6 X -6JIC X -6JIC 90 ELBOW - 220"	1
4	913751	HOSE-6 X -6JIC X -6JIC 90 ELBOW - 220"	1
5	913755	HOSE-6 X -6JIC X -6JIC - 161"	1
6	913756	HOSE-8 X -8JIC X -8JIC - 200"	1
7	913752	HOSE-6 X -6JIC X -6JIC - 185"	1
8	913753	HOSE-6 X -6JIC X -6JIC - 217"	1
9	913750	HOSE-6 X -6JIC X -6JIC 90 ELBOW - 102"	1
10	913750	HOSE-6 X -6JIC X -6JIC 90 ELBOW - 102"	1
11	913755	HOSE-6 X -6JIC X -6JIC - 161"	1
12	913756	HOSE-8 X -8JIC X -8JIC - 200"	1

Farm King



SPECIFICATIONS

PERFORMANCE.....	77
DIMENSIONS.....	77
HARDWARE TORQUE VALUES.....	78
Metric Chart.....	78
Imperial Chart.....	79
HYDRAULIC CONNECTION SPECIFICATIONS.....	80
O-Ring Fitting (Straight Thread).....	80
O-Ring Face Seal Connection.....	80
Flare Fitting.....	80
Port Seal (O-Ring Boss) Fitting.....	80
Tubelines And Hoses.....	80

Farm King



PERFORMANCE

Model	CX841	CX851	CX861	CX1041	CX1051	CX1061
Recommended HP	16	20	24	28	32	38
Capacity (bu/hr)	-	-	-	4400	4400	4400
Rim Size	15"	15"	15"	15"	15"	15"
Hub Type	5 bolt	5 bolt	5 bolt	5 bolt	5 bolt	5 bolt
Fuel Tank Capacity	6.5 US gal	6.5 US gal	6.5 US gal	6.5 US gal	6.5 US gal	6.5 US gal

Capacity will vary with field conditions. Tested on wheat, - 12.5% moisture using CX1041 model.

Fuel/Oil tanks are supplied with gas engine configuration only.

DIMENSIONS

Model	CX841	CX851	CX861	CX1041	CX1051	CX1061
Max Field Height	27.7'	31.7'	39.5'	27.2'	31.2'	39'
Field Width	8.8'	10.1'	10.1'	8.8'	10.1'	10.1'
Transport Width	8.8'	10.1'	10.1'	8.8'	10.1'	10.1'
Transport Height	12.8'	14.6'	14.3'	13'	14.8'	14.4'
Transport Length	40.2'	50.1'	60.4'	40.1'	50'	60.3'

Note: Dimensions are approximate measurements.

HARDWARE TORQUE VALUES

Metric Chart

NOTE: Do not use the values listed in the charts if a different torque value or tightening procedure is specified in this manual for a specific application. Torque values listed are for general use only.

Use the following charts to determine the correct torque when checking, adjusting or replacing hardware. **Torque values are listed in newton-meters (inch* or foot pounds) for normal assembly applications.**

Nominal Size	Class 5.8		Class 8.8		Class 10.9		Lock nuts
	Unplated	Plated W / ZnCr	Unplated	Plated W / ZnCr	Unplated	Plated W / ZnCr	CL.8 w/ CL. 8.8 Bolt
M4	1.7 (15*)	2.2 (19*)	2.6 (23*)	3.4 (30*)	3.7 (33*)	4.8 (42*)	1.8 (16*)
M6	5.8 (51*)	7.6 (67*)	8.9 (79*)	12 (102*)	13 (115*)	17 (150*)	6.3 (56*)
M8	14 (124*)	18 (159*)	22 (195*)	28 (248*)	31 (274*)	40 (354*)	15 (133*)
M10	28 (21)	36 (27)	43 (32)	56 (41)	61 (45)	79 (58)	30 (22)
M12	49 (36)	63 (46)	75 (55)	97 (72)	107 (79)	138 (102)	53 (39)
M16	121 (89)	158 (117)	186 (137)	240 (177)	266 (196)	344 (254)	131 (97)
M20	237 (175)	307 (226)	375 (277)	485 (358)	519 (383)	671 (495)	265 (195)
M24	411 (303)	531 (392)	648 (478)	839 (619)	897 (662)	1160 (855)	458 (338)

NOTE: Torque values shown with * are inch pounds.

Identification of Hex Cap Screws and Carriage Bolts - Classes 5 and up

MANUFACTURER'S IDENTIFICATION

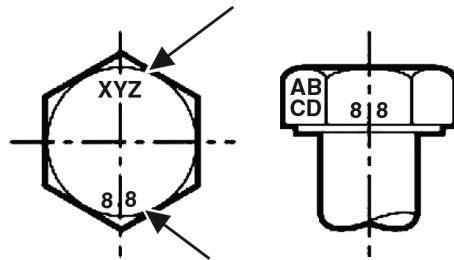

PROPERTY CLASS

Identification of Hex Nuts and Lock Nuts - Classes 5 and up

MANUFACTURER'S IDENTIFICATION

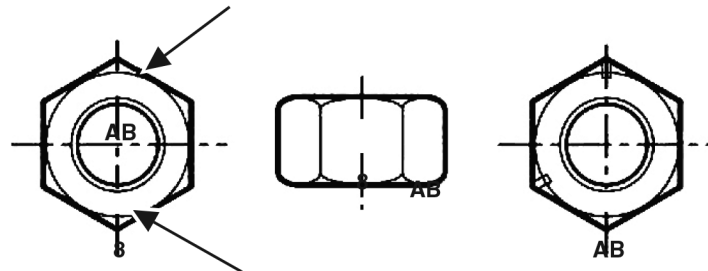

PROPERTY CLASS

Imperial Chart

NOTE: Do not use the values listed in the charts if a different torque value or tightening procedure is specified in this manual for a specific application. Torque values listed are for general use only.

Use the following charts to determine the correct torque when checking, adjusting or replacing hardware. **Torque values are listed in newton-meters (inch* or foot pounds) for normal assembly applications.**

Nominal Size	SAE Grade 5		SAE Grade 8		LOCK NUTS			
	Unplated or Plated Silver	Plated W / ZnCr Gold	Unplated or Plated Silver	Plated W / ZnCr Gold	Unplated or Plated Silver	Plated W / ZnCr Gold	Grade W / Gr. 5 Bolt	Grade W / Gr. 8 Bolt
1/4	6.2 (55*)	8.1 (72*)	9.7 (86*)	12.6 (112*)	13.6 (121*)	17.7 (157*)	6.9 (61*)	9.8 (86*)
5/16	13 (115*)	17 (149*)	20 (178*)	26 (229*)	28 (250*)	37 (324*)	14 (125*)	20 (176*)
3/8	23 (17)	30 (22)	35 (26)	46 (34)	50 (37)	65 (48)	26 (19)	35 (26)
7/16	37 (27)	47 (35)	57 (42)	73 (54)	80 (59)	104 (77)	41 (30)	57 (42)
1/2	57 (42)	73 (54)	87 (64)	113 (83)	123 (91)	159 (117)	61 (45)	88 (64)
9/16	81 (60)	104 (77)	125 (92)	163 (120)	176 (130)	229 (169)	88 (65)	125 (92)
5/8	112 (83)	145 (107)	174 (128)	224 (165)	244 (180)	316 (233)	122 (90)	172 (127)
3/4	198 (146)	256 (189)	306 (226)	397 (293)	432 (319)	560 (413)	217 (160)	306 (226)
7/8	193 (142)	248 (183)	495 (365)	641 (473)	698 (515)	904 (667)	350 (258)	494 (364)
1	289 (213)	373 (275)	742 (547)	960 (708)	1048 (773)	1356 (1000)	523 (386)	739 (545)

NOTE: Torque values shown with * are inch pounds.

Identification of Hex Cap Screws and Carriage Bolts



SAE GRADE 2 BOLTS



SAE GRADE 5 BOLTS



SAE GRADE 8 BOLTS



SAE GRADE 2 NUTS



SAE GRADE 2 NUTS



SAE GRADE 2 NUTS

Identification of Hex Nuts and Lock Nuts

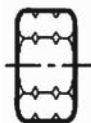

Grade A - No Notches

Grade B - One Circumferential Notch

Grade C - One Circumferential Notches

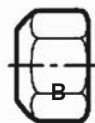

Grade A - No Mark

Grade B - Letter B

Grade C - Letter C

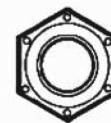

Grade A - No Marks

Grade B - Three Marks

Grade C - Six Marks

(Marks not always located at corners)

HYDRAULIC CONNECTION SPECIFICATIONS

O-Ring Fitting (Straight Thread)

Lubricate the O-ring before installing the fitting. Loosen the jam nut and install the fitting. Tighten the jam nut until the washer is tight against the surface.

O-Ring Face Seal Connection

O-ring Face Seal Tightening Torque		
Tubeline O.D.	Thread Size	N•m (ft-lb)
1/4"	9/16" - 18	13 (18)
3/8"	11/16" - 16	22 (30)
1/2"	13/16" - 16	40 (54)
5/8"	1" - 14	60 (81)
3/4"	1-3/16" - 12	84 (114)
7/8"	1-3/16" - 12	98 (133)
1"	1-7/16" - 12	118 (160)
1-1/4"	1-11/16" - 12	154 (209)
1-1/2"	2" - 12	163 (221)

When the fitting is tightened, you can feel when the fitting is tight to eliminate leakage caused by under or over torqued fittings. Use petroleum jelly to hold the O-ring in position until the fittings are assembled.

Flare Fitting

Flare Fitting Tightening Torque		
Tubeline O.D.	Thread Size	N • m (ft-lb)
1/4"	7/16" - 20	13 (18)
5/16"	1/2" - 20	17 (23)
3/8"	9/16" - 18	22 (30)
1/2"	3/4" - 16	40 (54)
5/8"	7/8" - 14	60 (81)
3/4"	1-1/16" - 12	84 (114)
7/8"	1-3/16" - 12	98 (133)
1"	1-5/16" - 12	118 (160)
1-1/4"	1-5/8" - 12	154 (209)
1-1/2"	1-7/8" - 12	163 (221)
2"	2-1/2" - 12	252 (342)

Tighten until the nut makes contact with the seat. Use the chart [Figure 57] to find the correct tightness needed.

Port Seal (O-Ring Boss) Fitting

Port Seal And O-ring Boss Tightening Torque		
Tubeline O.D.	Thread Size	N•m (ft-lb)
1/4"	7/16" - 20	13 (18)
3/8"	9/16" - 18	22 (30)
1/2"	3/4" - 16	40 (54)
5/8"	7/8" - 14	60 (81)
3/4"	1-1/16" - 12	84 (114)
7/8"	1-3/16" - 12	98 (133)
1"	1-5/16" - 12	118 (160)
1-1/8"	1-7/16" - 12	154 (209)
1-1/4"	1-5/8" - 12	163 (221)

Note: Port seal and nut, washer and O-ring (O-ring Boss) fittings use the same tightening torque valve chart [Figure 58].

If a torque wrench cannot be used, use the following method.

Tighten the nut until it just makes metal to metal contact, you can feel the resistance.

Tighten the nut with a wrench no more than one hex flat maximum.

Do not over tighten the port seal fitting.

Note: If a torque wrench cannot be used, use the hex flat tightening method as an approximate guideline.

Note: Port seal fittings are not recommended in all applications. Use O-ring boss fittings in these applications.

Tubelines And Hoses

Replace any tubelines that are bent or flattened. They will restrict flow, which will slow hydraulic action and cause heat.

Replace hoses which show signs of wear, damage or weather cracked rubber.

Always use two wrenches when loosening and tightening hose or tubeline fittings.

WARRANTY

FARM KING BASE LIMITED WARRANTY.....	83
Repair Parts Limited Warranty.....	83
What Is Not Covered.....	83
Authorized Dealer And Labor Costs.....	83
Warranty Requirements.....	84

Farm King



FARM KING BASE LIMITED WARRANTY

Farm King provides this warranty only to original retail purchasers of its products. Farm King warrants to such purchasers that all Farm King manufactured parts and components used and serviced as provided for in the Operator's Manual shall be free from defects in materials and workmanship for a period following delivery to the original retail purchaser of two (2) years. This limited warranty applies only to those parts and components manufactured by Farm King. Parts and components manufactured by others are subject to their manufacturer's warranties, if any.

Farm King will fulfill this limited warranty by, at its option, repairing or replacing any covered part that is defective or is the result of improper workmanship, provided that the part is returned to Farm King within thirty (30) days of the date that such defect or improper workmanship is, or should have been, discovered. Parts must be returned through the selling representative and the buyer must prepay transportation charges.

Farm King will not be responsible for repairs or replacements that are necessitated, in whole or part, by the use of parts not manufactured by or obtained from Farm King. Under no circumstances are component parts warranted against normal wear and tear. There is no warranty on product pump seals, product pump bearings, rubber product hoses, pressure gauges, or other components that require replacement as part of normal maintenance.

Repair Parts Limited Warranty

Farm King warrants genuine Farm King replacement parts purchased after the expiration of the Farm King Limited Warranty, and used and serviced as provided for in the Operator's Manual, to be free from defects in materials or workmanship for a period of thirty (30) days from the invoice date for the parts. Farm King will fulfill this limited warranty by, at its option, repairing or replacing any covered part that is defective or is the result of improper workmanship, provided that the part is returned to Farm King within thirty (30) days of the date that such defect or improper workmanship is, or should have been, discovered. Such parts must be shipped to the Farm King factory at the purchaser's expense.

What Is Not Covered

Under no circumstances does this limited warranty cover any components or parts that have been subject to the following: negligence; alteration or modification not approved by Farm King; misuse; improper storage; lack of reasonable and proper maintenance, service, or repair; normal wear; damage from failure to follow operating instructions; accident; and/or repairs that have been made with parts other than those manufactured, supplied, and or authorized by Farm King.

Authorized Dealer And Labor Costs

Repairs eligible for labor under this limited warranty must be made by Farm King or an authorized Farm King dealer. Farm King retains the exclusive discretion to determine whether it will pay labor costs for warranty repairs or replacements, and the amount of such costs that it will pay and the time in which the repairs will be made. If Farm King determines that it will pay labor costs for warranty work, it will do so by issuing a credit to the dealer's or distributor's account. Farm King will not approve or pay invoices sent for repairs that Farm King has not previously approved. Warranty service does not extend the original term of this limited warranty. Payment of labor costs will only be considered on repairs made to manufactured parts and components that have been found defective during a period of one (1) year following delivery to the original retail purchaser.

Warranty Requirements

To be covered by warranty, each new product must be registered with Farm King within thirty (30) days of delivery to original retail purchaser. If the customer decides to purchase replacement components before the warranty disposition of such components is determined, Farm King will bill the customer for such components and then credit the replacement invoice for those components later determined to be covered by this limited warranty. Any such replacement components that are determined not to be covered by this limited warranty will be subject to the terms of the invoice and shall be paid for by the purchaser.

EXCLUSIVE EFFECT OF WARRANTY AND LIMITATION OF LIABILITY

TO THE EXTENT PERMITTED BY LAW, FARM KING DISCLAIMS ANY WARRANTIES, REPRESENTATIONS, OR PROMISES, EXPRESS OR IMPLIED, AS TO THE QUALITY, PERFORMANCE, OR FREEDOM FROM DEFECT OF THE COMPONENTS AND PARTS COVERED BY THIS WARRANTY AND NOT SPECIFICALLY PROVIDED FOR HEREIN.

TO THE EXTENT PERMITTED BY LAW, FARM KING DISCLAIMS ANY IMPLIED WARRANTIES OF MERCHANTABILITY AND FITNESS FOR A PARTICULAR PURPOSE ON ITS PRODUCTS COVERED HEREIN, AND DISCLAIMS ANY RELIANCE BY THE PURCHASER ON FARM KING'S SKILL OR JUDGMENT TO SELECT OR FURNISH GOODS FOR ANY PARTICULAR PURPOSE. THE PURCHASER'S ONLY AND EXCLUSIVE REMEDIES IN CONNECTION WITH THE BREACH OR PERFORMANCE OF ANY WARRANTY ON FARM KING'S PRODUCTS ARE THOSE SET FORTH HEREIN. IN NO EVENT SHALL FARM KING BE LIABLE FOR INCIDENTAL OR CONSEQUENTIAL DAMAGES (INCLUDING, BY WAY OF EXAMPLE ONLY AND NOT LIMITATION, LOSS OF CROPS, LOSS OF PROFITS OR REVENUE, OTHER COMMERCIAL LOSSES, INCONVENIENCE, OR COST OF REPLACEMENT OF RENTAL EQUIPMENT). IN NO EVENT SHALL FARM KING'S CONTRACT OR WARRANTY LIABILITY EXCEED THE PURCHASE PRICE OF THE PRODUCT. (Note that some states do not allow limitations on how long an implied warranty lasts or the exclusion or limitation of incidental or consequential damages, so the above limitations and exclusion may not apply to you.) This warranty gives you specific legal rights and you may also have other rights, which vary from state to state.

Farm King neither assumes nor authorizes any person or entity, including its selling representatives, to assume any other obligations or liability in connections with the sale of covered equipment, or to make any other warranties, representations, or promises, express or implied, as to the quality, performance, or freedom from defect of the components and parts covered herein. No one is authorized to alter, modify, or enlarge this limited warranty, or its exclusions, limitations and reservations.

Corrections of defects and improper workmanship in the manner, and for the applicable time periods, provided for herein shall constitute fulfillment of all responsibilities of Farm King to the purchaser, and Farm King shall not be liable in negligence, contract, or on any other basis with respect to the subject equipment.

This limited warranty is subject to any existing conditions of supply which may directly affect Farm King's ability to obtain materials or manufacturer replacement parts.

Buhler Industries Inc. reserves the right to make improvements in design or changes in specifications to its products at anytime, without incurring any obligation to owners of units previously sold.

www.farm-king.com

Farm King

301 Mountain Street South
Morden, MB R6M 1X7
Toll Free: 888.524.1004
E-mail: info@buhler.com
www.farm-king.com

Equipment shown is subject to change without notice.
©2017 Buhler Trading Inc. Printed in Canada TSX:BU1

bühler | a division of Buhler Industries Inc.