

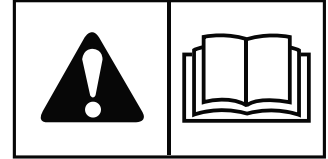

OPERATOR'S MANUAL

F60Z Series

Zero-Turn Riding Mower



Model

5901548
5901549
5901688
5901689

Description

F60ZB2536
F60ZKAV1936
F60ZKAV1936 CAL
F60ZB2536 CAL

**This manual is available in Spanish. For a copy, contact your Ferris dealer or www.ferrismowers.com.
Este manual está disponible en Español. Para obtener una copia, póngase en contacto con su distribuidor Ferris o www.ferrismowers.com.**

Table of Contents:

Products Covered by This Manual	3	Speed Balancing Adjustment.....	27
Identification Tag Location	3	Checking Tire Pressures.....	28
Product Identification Tag (Stamped)	3	Cutting Height Adjustment.....	28
Operator Safety	4	Foot Pedal Adjustment.....	28
Operating Safely.....	4	Neutral Adjustment.....	29
Slope Identification Guide.....	6	Return-To-Neutral Adjustment.....	29
Safety Rules and Information.....	6	Neutral Lockout Adjustment.....	29
Safety Decals.....	9	Parking Brake Adjustment.....	30
Safety Icons.....	10	Deck Lift Rod Timing Adjustment.....	30
Safety Icons for Optional Jack Kit Accessory.....	10	Deck Leveling Adjustment.....	31
Safety Alert Symbol and Signal Words.....	10	Mower Deck Drive Belt Replacement.....	32
Safety Interlock System.....	10	Transaxle Drive Belt Replacement.....	33
Features and Controls	11	Cleaning the Battery and Cables.....	34
Control Functions and Locations.....	11	Battery Service.....	34
Zero-Turn Rider Controls.....	11	Troubleshooting	36
Instrument Control Panels.....	12	Troubleshooting Charts.....	36
Operation	13	Troubleshooting Common Cutting Problems.....	37
Before First Time Operation.....	13	Specifications	38
Checks Before Starting.....	14	Warranty	39
Starting the Engine.....	14	Warranty Statement.....	39
Stopping the Rider.....	14		
Zero-Turn Driving Practice.....	14		
Mowing.....	16		
Mowing Recommendations.....	17		
Pushing the Unit by Hand.....	18		
Attaching a Trailer.....	19		
Storage.....	19		
Maintenance Schedule	20		
Maintenance Procedures	21		
Service and Maintenance Safety.....	21		
Checking / Adding Fuel.....	21		
Replacing the Fuel Filter.....	21		
Check Engine Oil Level.....	21		
Changing the Engine Oil and Filter.....	21		
Engine Maintenance.....	22		
Inspect Muffler and Spark Arrester.....	22		
Fuse Location and Identification.....	22		
Raising and Lowering the Seat Plate.....	22		
Floor Pan Removal & Installation.....	22		
Lubrication.....	23		
Lubricate the Front Casters.....	23		
Check / Fill Transmission Oil Level.....	24		
Transmission Oil Filter Change.....	24		
Purging the Air from the Hydraulic System.....	25		
Servicing the Mower Blades.....	25		
Seat Adjustment.....	27		
Ground Speed Control Lever Adjustment.....	27		

Thank you for purchasing this quality-built Ferris Commercial Zero Turn Mower. We're pleased that you've placed your confidence in the Ferris brand. When operated and maintained according to the manuals, your Ferris product will provide many years of dependable service.

The manuals contain safety information to make you aware of the hazards and risks associated with the unit and how to avoid them. This Commercial Zero Turn Mower was designed to be used as described in operator's manual and is not intended for any other purpose. It is important that you read and understand the instructions thoroughly before attempting to start or operate this equipment. Save these original instructions for future reference.

This product requires final assembly before use. Refer to the setup guide for instructions on final assembly procedures. Follow the instructions completely.

Products Covered by This Manual

The following products are covered by this manual:

5901548, 5901549, 5601688 & 5901689

The images in this document are representative, and are meant to complement the instructional copy they accompany. Your unit may vary from the images displayed. *LEFT* and *RIGHT* are as seen from the operator's position.

Ferris is a registered trademark of Briggs & Stratton Corporation.

Ferris

5375 North Main Street

Munnsville, NY 13409-4003

(800) 933-6175

ferrismowers.com

Identification Tag Location

The product identification tag for the zero-turn rider (A, Figure 1) can be found in the location shown.

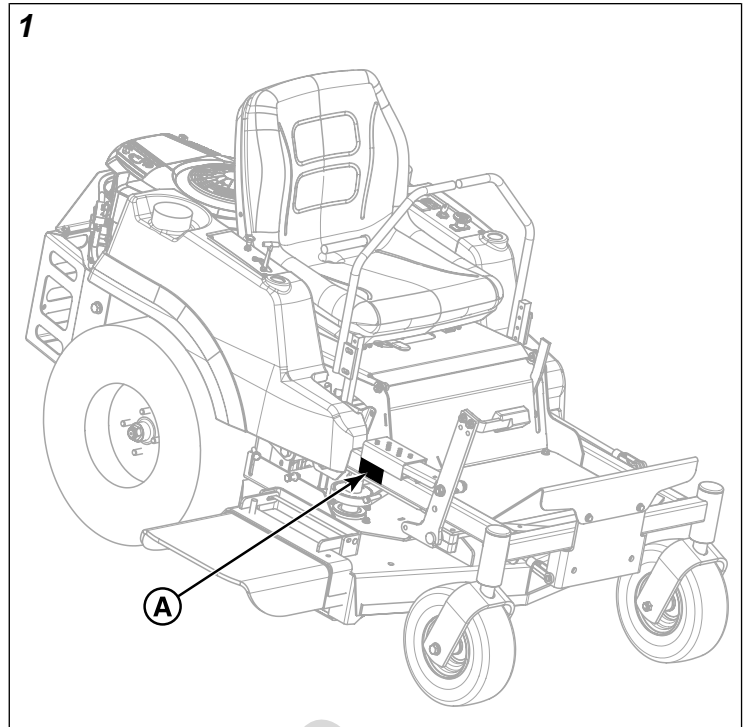

Product Identification Tag (Stamped)

BRIGGS & STRATTON CORPORATION	
MILWAUKEE, WI 53201, USA	
ASSEMBLED IN THE USA	
PART NO.	SERIAL NO.
XXXXXXX	XXXXXXXXXX

PRODUCT REFERENCE DATA	
Unit Model Number:	
Unit Serial Number:	
Mower Deck Model Number: (if applicable)	
Mower Deck Serial Number: (if applicable)	
Dealer Name:	
Date Purchased:	
ENGINE REFERENCE DATA	
Engine Make:	
Engine Model:	
Engine Type/Spec:	
Engine Code/Serial Number	

When contacting your authorized service dealer for replacement parts, service, or information you **MUST** have these numbers.

Note: For the location of the engine identification numbers, refer to engine owner's manual.

The Illustrated Parts List for this machine can be downloaded from ferrismowers.com. Please provide model and serial number when ordering replacement parts.

Operator Safety



This product can expose you to chemicals including gasoline engine exhaust, which is known to the State of California to cause cancer, and carbon monoxide, which is known to the State of California to cause birth defects or other reproductive harm. For more information go to www.P65Warnings.ca.gov.

Operating Safely

Read these safety rules and follow them closely. Failure to obey these rules could result in loss of control of unit, severe personal injury or death to you, or bystanders, or damage to property or equipment. **This mowing deck is capable of amputating hands and feet and throwing objects.**

The safety alert triangle (⚠) in text signifies important cautions or warnings which must be followed.

Operating Safety



Congratulations on purchasing a superior-quality piece of lawn and garden equipment. Our products are designed and manufactured to meet or exceed all industry standards for safety.

Do not operate this machine unless you have been trained. Reading and understanding this operator's manual is a way to train yourself.

Power equipment is only as safe as the operator. If it is misused, or not properly maintained, it can be dangerous! Remember, you are responsible for your safety and that of those around you.

Use common sense, and think through what you are doing. If you are not sure that the task you are about to perform can be safely done with the equipment you have chosen, ask a professional: contact your local authorized dealer.

Read the Manual

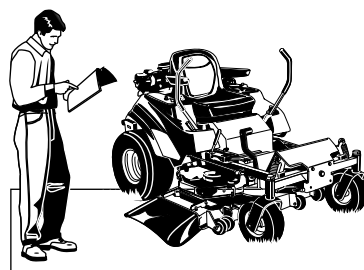

The operator's manual contains important safety information you need to be aware of BEFORE you operate your unit as well as DURING operation.

Safe operating techniques, an explanation of the product's features and controls, and maintenance information is included to help you get the most out of your equipment investment.

Be sure to completely read the Safety Rules and Information found on the following pages. Also completely read the Operation section.

Children

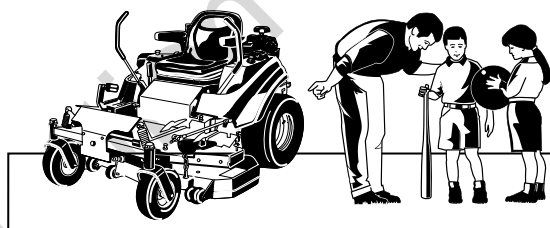

Tragic accidents can occur with children. Do not allow them anywhere near the area of operation. Children are often attracted to the unit and mowing activity. Never assume that children will remain where you last saw them. If there is a risk that children may enter the area where you are mowing, have another responsible adult watch them.

Slope Operation

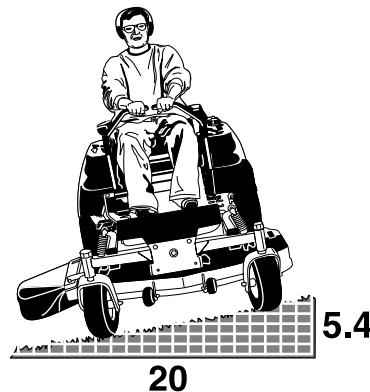

Operation on slopes can be dangerous. Using the unit on a slope that is too steep where you do not have adequate wheel traction (and control) can cause sliding, loss of steering, control, and possible rollover. You should not operate on a slope greater than a 5.4 foot rise over a 20 foot length (15 degrees).

Always mow across slopes, not up and down (to maintain traction on the wheels) and avoid sudden turns or rapid speed

changes. Reduce speed and use extreme caution on ALL slopes.

Also, note that the surface condition you are on can greatly impact your ability to safely operate this machine. Operating on wet or slippery slopes can cause sliding and loss of steering and control. Do not operate on slopes that are slippery, wet, or have soft soil conditions.

If you feel unsure about operating the unit on a slope, don't do it. It's not worth the risk.

Thrown Objects

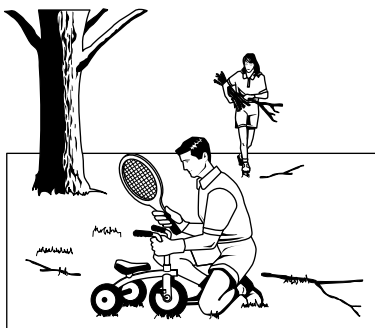

This unit has spinning mower blades. These blades can pick up and throw debris that could seriously injure a bystander. Be sure to clean up the area to be mowed and remove objects that could be thrown by the blade **BEFORE** you start mowing.

Do not operate this unit without the entire grass catcher or discharge guard (deflector) in place.

Also, do not allow anyone in the area while the unit is running! If someone does enter the area, shut the unit off immediately until they leave.

Moving Parts

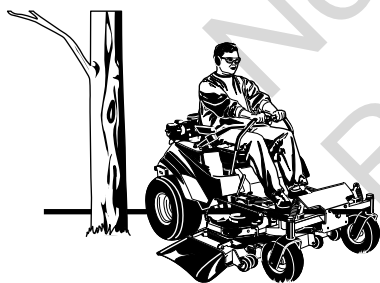

This equipment has many moving parts that can injure you or someone else. However, if you stay in the operator zone (stay seated in the seat), and follow the safety rules in this operator's manual, the unit is safe to operate.

The mower deck has spinning mower blades that can amputate hands and feet. Do not allow anyone near the unit while it is running! Keep safety devices (guards, shields, and switches) in place and working.

To help you, the operator, use this equipment safely, it is equipped with an operator-present safety system. Do NOT attempt to alter or bypass the system. See your dealer immediately if the system does not pass all the safety interlock system tests found in this manual.

Retaining Walls, Drop-Offs and Water

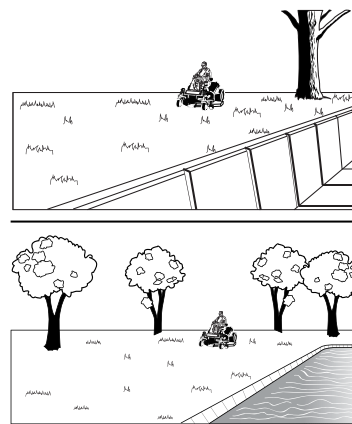

Retaining walls and drop-offs around steps and water are a common hazard. Give yourself a minimum of two mower widths of clearance around these hazards and hand-trim with a walk behind mower or string trimmer. Wheels dropping over retaining walls, edges, ditches, embankments, or into water can cause rollovers, which may result in serious injury, death, or drowning.

Fuel and Maintenance

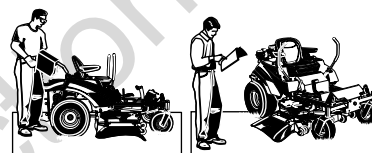

Always disengage all drives, shutoff the engine, and remove the key before doing any cleaning, refueling, or servicing.

Gasoline and its vapors are extremely flammable. Do not smoke while operating or refueling. Do not add fuel while engine is hot or running. Allow engine to cool for at least 3 minutes prior to adding fuel.

Do not add fuel indoors, in an enclosed trailer, garage, or any other enclosed area that is not well ventilated. Gasoline spills should be cleaned up promptly and before operation begins.

Gasoline should be stored only in sealed containers approved for fuel.

Proper maintenance is critical to the safety and performance of your unit. Keep the unit free of grass, leaves, and excess oil. Be sure to perform the maintenance procedures listed in this manual, especially periodically testing the safety system.

Enclosed Areas

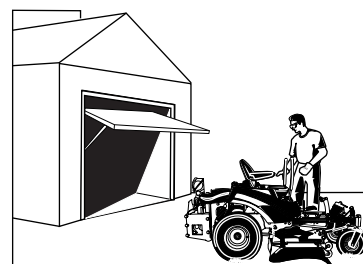

Only operate this unit outdoors and away from unventilated areas such as inside garages or enclosed trailers. The engine

emits poisonous carbon monoxide gas and prolonged exposure in an enclosed area can result in serious injury or death.

Slope Identification Guide

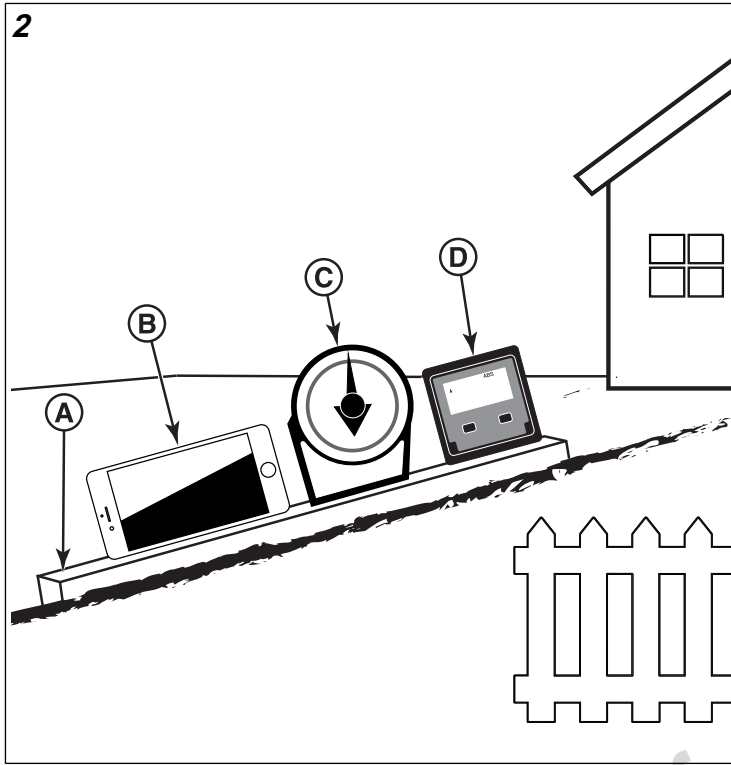

How to measure the slope of a lawn surface with a smartphone or an angle finder tool:



Do not operate on slopes greater than 15 degrees.

1. Use a straight edge at least two (2) feet long (A, Figure 2). A 2x4 or a straight piece of metal works well.
2. Angle finder tools.
 - a. **Use your smartphone:** Many smartphones (B, Figure 2) have an inclinometer (angle finder) located under the compass application (app). Or, search an app store for an Inclinometer app.
 - b. **Use angle finder tools:** Angle finder tools (C & D, Figure 2) are available at local hardware stores or online (also called inclinometer, protractor, angle meter, or angle gauge). Dial type (C) or digital type (D) work, others may not. Follow user instructions with the angle finder tool.
3. Place the two (2) feet long straight edge along the steepest part of the lawn slope. Place the board up and down the slope.
4. Lay the smartphone or angle finder tool on the straight edge and read the angle in degrees. This is the slope of your lawn.

Note: A paper gauge slope identification guide is included in your product literature packet and is also available to download from the manufacturer's website (ferrismowers.com).

Safety Rules and Information Training

- Read, understand, and follow all instructions in the manual and on the unit before starting. If the operator(s) or mechanic(s) can not read English it is the owner's responsibility to explain this material to them.
- Become familiar with the safe operation of the equipment, operator controls, and safety signs.
- All operators and mechanics should be trained. The owner is responsible for training the users.
- Only allow responsible adults, who are familiar with the instructions, to operate the unit.
- Never let children or untrained people operate or service the equipment. Local regulations may restrict the age of the operator.
- The owner/user can prevent and is responsible for accidents or injuries occurring to themselves, other people or property.
- Data indicates that operators, age 60 years and above, are involved in a large percentage of riding mower-related injuries. These operators should evaluate their ability to operate the riding mower safely enough to protect themselves and others from serious injury.

Preparation

- Evaluate the terrain to determine what accessories and attachments are needed to properly and safely perform the job. Use only accessories and attachments approved by the manufacturer.
- Wear appropriate clothing including safety shoes, safety glasses and ear protection. Long hair, loose clothing or jewelry may get tangled in moving parts.
- Inspect the area where the equipment is to be used and remove all objects such as rocks, toys and wire, which can be thrown by the machine.
- Use extra care when handling gasoline and other fuels. They are flammable and vapors are explosive.
- Use only an approved container.
- Never remove fuel cap or add fuel with the engine running. Allow engine to cool before refueling. Do not smoke.
- Never refuel or drain the machine indoors.
- Check that operator's presence controls, safety switches and shields are attached and functioning properly. Do not operate unless they are functioning properly.

Operation

- Never run an engine in an enclosed area.
- Mow only in the daylight or with good artificial light, keeping away from holes and hidden hazards.

- Be sure all drives are in neutral and parking brake is engaged before starting engine. Only start engine from the operator's position. Use seat belts if provided.
- Be sure of your footing while using pedestrian controlled equipment, especially when backing up. Walk, don't run. Reduced footing could cause slipping.
- Slow down and use extra care on hillsides. Be sure to travel in the recommended direction on hillsides. Turf conditions can affect the machines stability. Use caution when operating near drop-offs.
- Do not mow in reverse unless absolutely necessary. Always look down and behind before and while traveling in reverse.
- Be aware of the mower discharge direction and do not point it at anyone. Do not operate the mower without either the entire grass catcher or the deflector in place.
- Slow down and use caution when making turns and when changing directions on slopes.
- Never raise deck with the blades running.
- Never leave a running unit unattended. Always disengage the PTO, set parking brake, stop engine, and remove keys before dismounting. Keep hands and feet away from the cutting units.
- Turn off the PTO switch to disengage the blades when not mowing.
- Never operate with guards not securely in place. Be sure all interlocks are attached, adjusted properly and functioning properly.
- Never operate with the discharge deflector raised, removed or altered, unless using a grass catcher.
- Do not change the engine governor setting or overspeed the engine.
- Stop on level ground, lower implements, disengage drives, engage parking brake, shut off engine before leaving the operator's position for any reason including emptying the grass catchers or unclogging the chute.
- Stop equipment and inspect blades after striking objects or abnormal vibration occurs. Make necessary repairs before resuming operations.
- Keep hands and feet away from the cutting units.
- Look behind and down before backing up to be sure of a clear path.
- Never carry passengers and keep pets and bystanders away.
- Do not operate the unit while under the influence of alcohol or drugs.
- Slow down and use caution when making turns and crossing roads and sidewalks. Stop blades if not mowing.
- Use care when loading or unloading the machine into a trailer or truck.
- Use care when approaching blind corners, shrubs, trees or other objects that may obscure vision.
- To reduce fire hazard, keep unit free of grass, leaves & excess oil. Do not stop or park over dry leaves, grass or combustible materials.



WARNING

It is a violation of California Public Resource Code, Section 4442, to use or operate the engine on any forest-covered, brush-covered or grass-covered land unless the exhaust system is equipped with a spark arrester, as defined in Section 4442, maintained in effective working order. Other states or federal jurisdictions may have similar laws. Contact an Authorized Service Dealer to obtain a spark arrester designed for the exhaust system installed on this engine.

- OSHA regulations may require the use of hearing protection when exposed to sound levels greater than 85 dBA for an 8 hour time period.



CAUTION



This machine produces sound levels in excess of 85 dBA at the operator's ear and can cause hearing loss through extended periods of exposure.

Wear hearing protection when operating this machine.

Slope Operation

Slopes are a major factor related to loss-of-control and tip-over accidents, which can result in severe injury or death. All slopes require extra caution. If you cannot back up the slope or if you feel uneasy on it, do not drive on it.



WARNING



Do not use this machine on slopes greater than 15°.*

Select slow ground speed before driving onto slope. Use extra caution when operating on slopes with rear-mounted grass catchers.

Mow across the face of slopes, not up and down, use caution when changing directions and **DO NOT START OR STOP ON SLOPE.**

* This limit was determined per CEN Standard EN 836:1997, Section 5.2.2 and is based on the EN 836 Stability Test procedure described in Section 4.2.4.2. The 15 degree "limit of stability" is equal to 50% of the angle at which machine lift-off occurred in static tests. Actual dynamic stability may vary depending on operating conditions.

Do:

- Mow across slopes, not up and down.
- Remove obstacles such as rocks, tree limbs, etc.
- Watch for holes, ruts, or bumps. Uneven terrain could overturn the unit. Tall grass can hide obstacles.
- Use slow speed. Choose a slow speed so that you will not have to stop or change speed while on the slope.
- Use extra care with grass catchers or other attachments. These can change the stability of the unit.
- Keep all movement on the slopes slow and gradual. Do not make sudden changes in speed or direction.
- See your authorized dealer for recommendations of available weights to improve stability.

Do NOT:

- Avoid starting, stopping, or turning on a slope. If tires lose traction (i.e. machine stops forward motion on a slope), disengage the blade(s) (PTO) and drive slow off the slope.
- Do not turn on slopes unless necessary, and then, turn slowly and gradually uphill, if possible. Never mow down slopes.
- Do not mow near drop-offs, ditches, or embankments. The operator could lose footing or balance or mower could suddenly turn over if a wheel is over the edge of a cliff or ditch, or if an edge caves in.
- Do not mow on wet grass. Reduced footing or traction could cause sliding.
- Do not try to stabilize the unit by putting your foot on the ground. (ride-on units).
- Do not mow excessively steep slopes.
- Do not use grass catcher on steep slopes.
- Do not mow slopes if you cannot back up them.

Towed Equipment (Ride-On Units)

- Tow only with a machine that has a hitch designed for towing. Do not attach towed equipment except at the hitch point.
- Follow the manufacturer's recommendations for weight limit for towed equipment and towing on slopes. See attaching a trailer under OPERATION.
- Never allow children or others in or on towed equipment.
- On slopes, the weight of the towed equipment may cause loss of traction and loss of control.
- Travel slowly and allow extra distance to stop.
- Do not shift to neutral and coast down hill.

Children

Tragic accidents can occur if the operator is not alert to the presence of children. Children are often attracted to the unit and the mowing activity. Never assume that children will remain where you last saw them.

- Keep children out of the mowing area and under the watchful care of another responsible adult.
- Be alert and turn unit off if children enter the area.
- Before and during reverse operation, look behind and down for small children.
- Never carry children, even with the blade(s) off. They may fall off and be seriously injured or interfere with safe unit operation. Children who have been given rides in the past may suddenly appear in the mowing area for another ride and be run over or backed over by the machine.
- Never allow children to operate the unit.
- Use extra care when approaching blind corners, shrubs, trees, or other objects that may obscure vision.

Emissions

- Engine exhaust from this product contains chemicals known, in certain quantities, to cause cancer, birth defects, or other reproductive harm.
- Look for the relevant Emissions Durability Period and Air Index information on the engine emissions label.

Service and Maintenance

To avoid personal injury or property damage, use extreme care in handling gasoline. Gasoline is extremely flammable and the vapors are explosive.

Safe Handling of Gasoline

- Extinguish all cigarettes, cigars, pipes, and other sources of ignition.
- Use only approved gasoline containers.
- Never remove the gas cap or add fuel with the engine running. Allow the engine to cool before refueling.
- Never fuel the machine indoors.
- Never store the machine or fuel container where there is an open flame, spark, or pilot light such as near a water heater or other appliance.
- Never fill containers inside a vehicle or on a truck bed with a plastic bed liner. Always place containers on the ground away from your vehicle before filling.
- Remove gas-powered equipment from the truck or trailer and refuel it on the ground. If this is not possible, then refuel such equipment on a trailer with a portable container, rather than from a gasoline dispenser nozzle.
- Keep nozzle in contact with the rim of the fuel tank or container opening at all times until fueling is complete. Do not use a nozzle lock-open device.
- If fuel is spilled on clothing, change clothing immediately.
- Never over-fill the fuel tank. Replace gas cap and tighten securely.
- Use extra care in handling gasoline and other fuels. They are flammable and vapors are explosive.
- If fuel is spilled, do not attempt to start the engine but move the machine away from the area of spillage and avoid creating any source of ignition until fuel vapors have dissipated.
- Replace all fuel tank caps and fuel container caps securely.

Maintenance and Storage

- Always observe safe refueling and fuel handling practices when refueling the unit after transportation or storage.
- Always follow the engine manual instructions for storage preparations before storing the unit for both short and long term periods.
- Always follow the engine manual instructions for proper start-up procedures when returning the unit to service.
- Never store the machine or fuel container inside where there is an open flame, such as in a water heater. Allow unit to cool before storing.

- Shut off fuel while storing or transporting. Do not store fuel near flames or drain indoors.
- Keep all hardware, especially blade attachment bolts, tight and keep all parts in good working condition. Replace all worn or damaged decals.
- Never tamper with safety devices. Check their proper operation regularly.
- Disengage drives, lower implement, set parking brake, stop engine and remove key or disconnect spark plug wire. Wait for all movement to stop before adjusting, cleaning or repairing.
- Clean grass and debris from cutting units, drives, mufflers, and engine to prevent fires. Clean up oil or fuel spillage.
- Let engine cool before storing and do not store near flame.
- Stop and inspect the equipment if you strike an object. Repair, if necessary, before restarting.
- Park machine on level ground. Never allow untrained personnel to service machine.
- Use jack stands to support components when required.
- Carefully release pressure from components with stored energy.
- Disconnect battery or remove spark plug wire before making any repairs. Disconnect the negative terminal first and the positive last. Reconnect positive first and negative last.
- Use care when checking blades. Wrap the blade(s) or wear gloves, and use caution when servicing them. Only replace blades. Never straighten or weld them.
- Keep hands and feet away from moving parts. If possible, do not make adjustments with the engine running.
- Charge batteries in an open well ventilated area, away from spark and flames. Unplug charger before connecting or disconnecting from battery. Wear protective clothes and use insulated tools.
- Grass catcher components are subject to wear, damage, and deterioration, which could expose moving parts or allow objects to be thrown. Frequently check components and replace with manufacturer's recommended parts, when necessary.
- Check brake operation frequently. Adjust and service as required.
- Use only factory authorized replacement parts when making repairs.
- Always comply with factory specifications on all settings and adjustments.
- Only authorized service locations should be utilized for major service and repair requirements.
- Never attempt to make major repairs on this unit unless you have been properly trained. Improper service procedures can result in hazardous operation, equipment damage and voiding of manufacturer's warranty.
- Units with hydraulic pumps, hoses, or motors: **WARNING:** Hydraulic fluid escaping under pressure may have sufficient force to penetrate skin and cause serious injury. If foreign fluid is injected into the skin it must be surgically removed within a few hours by a doctor familiar with this form of injury or gangrene may result. Keep body and hands away from

pin holes or nozzles that eject hydraulic fluid under high pressure. Use paper or cardboard, and not hands, to search for leaks. Make sure all hydraulic fluid connections are tight and all hydraulic hoses and lines are in good condition before applying pressure to the system. If leaks occur, have the unit serviced immediately by your authorized dealer.

- **WARNING:** Stored energy device. Improper release of springs can result in serious personal injury. Springs should be removed by an authorized technician.
- Models equipped with an engine radiator: **WARNING:** Stored energy device. To prevent serious bodily injury from hot coolant or steam blow-out, never attempt to remove the radiator cap while the engine is running. Stop the engine and wait until it is cool. Even then, use extreme care when removing the cap.

Safety Decals

Before operating your unit, read the safety decals. The cautions and warnings are for your safety. To avoid a personal injury or damage to the unit, understand and follow all safety decals.



WARNING

If any safety decals become worn or damaged, and cannot be read, order replacement decals from your local dealer.

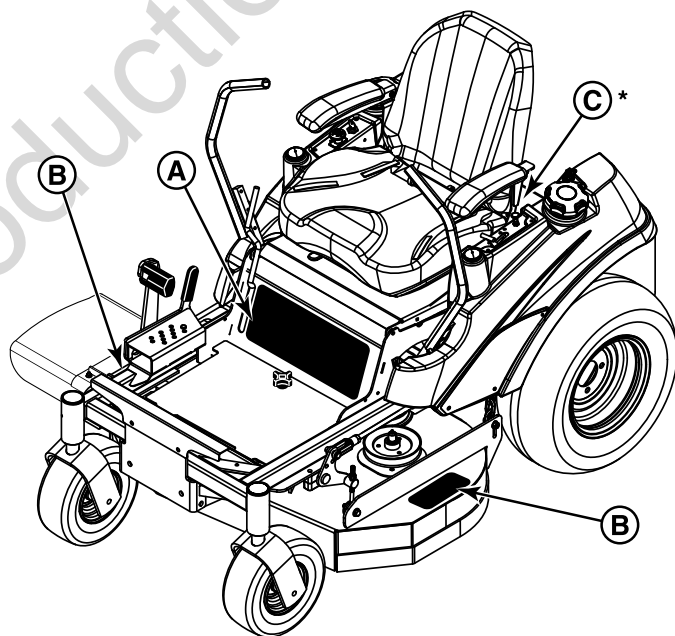

* Located underneath the seat on a plate between the transmission oil tanks.

A	<p>Part No.: 5103595 - Decal, Main Safety</p> <table border="1"> <tr> <td data-bbox="852 1711 1096 1921"> <p>WARNING</p> <p>Avoid serious injury or death</p> <ul style="list-style-type: none"> Read operator's manual before using this product. Do NOT operate this machine unless you are trained. Know the location and function of all controls. Keep safety devices (guards, shields, switches, etc.) in place and working. Remove objects that could be thrown by the blades. Be sure blades and engine are stopped before shifting handle or feet near blades. When leaving machine, shut off, remove key and set parking brake. <p>Fire Hazard</p> <ul style="list-style-type: none"> Gasoline is flammable. Debris is combustible. Allow engine to cool for at least 3 minutes before refueling. Keep unit cleaned of debris. This equipment may create sparks that can start fires around dry vegetation. A spark arrester may be required. Contact local fire agencies for regulations relating to this prevention requirements. </td> <td data-bbox="1096 1711 1307 1921"> <p>Amputation hazard</p> <p>Rotating blades cut off arms and legs.</p> <ul style="list-style-type: none"> Stop the mower when children or others are near. Do not carry rides (especially children) even with the blades off. They may fall off or return to another ride when you are not expecting it. Look down, behind and to the side before changing direction. <p>Loss of control and rollover hazard</p> <p>Operating on slopes can be hazardous and cause loss of control and rollovers.</p> <ul style="list-style-type: none"> Avoid sudden turns or rapid speed changes. Reduce speed and use extreme caution on slopes. Do not operate on slopes over 15 degrees. Engine stops forward motion on a slope, stop the blades and drive slowly off the slope. </td> <td data-bbox="1307 1711 1485 1921"> <p>Water, retaining walls and drop-off hazards</p> <p>Without dropping over edges may result in serious injury, death or drowning.</p> <ul style="list-style-type: none"> Do NOT operate near water, retaining walls or drop-offs. Give yourself a minimum of ten-foot, width-of-slopes clearance around these hazards. <p>Wet or soft slope hazard</p> <p>Wet or soft slopes can cause sliding and loss of control.</p> <ul style="list-style-type: none"> Do NOT operate on slopes when grass is wet. Do NOT operate on slopes when soil is soft (such as after heavy rains). </td> </tr> </table>	<p>WARNING</p> <p>Avoid serious injury or death</p> <ul style="list-style-type: none"> Read operator's manual before using this product. Do NOT operate this machine unless you are trained. Know the location and function of all controls. Keep safety devices (guards, shields, switches, etc.) in place and working. Remove objects that could be thrown by the blades. Be sure blades and engine are stopped before shifting handle or feet near blades. When leaving machine, shut off, remove key and set parking brake. <p>Fire Hazard</p> <ul style="list-style-type: none"> Gasoline is flammable. Debris is combustible. Allow engine to cool for at least 3 minutes before refueling. Keep unit cleaned of debris. This equipment may create sparks that can start fires around dry vegetation. A spark arrester may be required. Contact local fire agencies for regulations relating to this prevention requirements. 	<p>Amputation hazard</p> <p>Rotating blades cut off arms and legs.</p> <ul style="list-style-type: none"> Stop the mower when children or others are near. Do not carry rides (especially children) even with the blades off. They may fall off or return to another ride when you are not expecting it. Look down, behind and to the side before changing direction. <p>Loss of control and rollover hazard</p> <p>Operating on slopes can be hazardous and cause loss of control and rollovers.</p> <ul style="list-style-type: none"> Avoid sudden turns or rapid speed changes. Reduce speed and use extreme caution on slopes. Do not operate on slopes over 15 degrees. Engine stops forward motion on a slope, stop the blades and drive slowly off the slope. 	<p>Water, retaining walls and drop-off hazards</p> <p>Without dropping over edges may result in serious injury, death or drowning.</p> <ul style="list-style-type: none"> Do NOT operate near water, retaining walls or drop-offs. Give yourself a minimum of ten-foot, width-of-slopes clearance around these hazards. <p>Wet or soft slope hazard</p> <p>Wet or soft slopes can cause sliding and loss of control.</p> <ul style="list-style-type: none"> Do NOT operate on slopes when grass is wet. Do NOT operate on slopes when soil is soft (such as after heavy rains).
<p>WARNING</p> <p>Avoid serious injury or death</p> <ul style="list-style-type: none"> Read operator's manual before using this product. Do NOT operate this machine unless you are trained. Know the location and function of all controls. Keep safety devices (guards, shields, switches, etc.) in place and working. Remove objects that could be thrown by the blades. Be sure blades and engine are stopped before shifting handle or feet near blades. When leaving machine, shut off, remove key and set parking brake. <p>Fire Hazard</p> <ul style="list-style-type: none"> Gasoline is flammable. Debris is combustible. Allow engine to cool for at least 3 minutes before refueling. Keep unit cleaned of debris. This equipment may create sparks that can start fires around dry vegetation. A spark arrester may be required. Contact local fire agencies for regulations relating to this prevention requirements. 	<p>Amputation hazard</p> <p>Rotating blades cut off arms and legs.</p> <ul style="list-style-type: none"> Stop the mower when children or others are near. Do not carry rides (especially children) even with the blades off. They may fall off or return to another ride when you are not expecting it. Look down, behind and to the side before changing direction. <p>Loss of control and rollover hazard</p> <p>Operating on slopes can be hazardous and cause loss of control and rollovers.</p> <ul style="list-style-type: none"> Avoid sudden turns or rapid speed changes. Reduce speed and use extreme caution on slopes. Do not operate on slopes over 15 degrees. Engine stops forward motion on a slope, stop the blades and drive slowly off the slope. 	<p>Water, retaining walls and drop-off hazards</p> <p>Without dropping over edges may result in serious injury, death or drowning.</p> <ul style="list-style-type: none"> Do NOT operate near water, retaining walls or drop-offs. Give yourself a minimum of ten-foot, width-of-slopes clearance around these hazards. <p>Wet or soft slope hazard</p> <p>Wet or soft slopes can cause sliding and loss of control.</p> <ul style="list-style-type: none"> Do NOT operate on slopes when grass is wet. Do NOT operate on slopes when soil is soft (such as after heavy rains). 		
B	<p>Part No.: 7101665 - Decal, Danger Do Not Operate w/o Deflector</p>			

⚠ DANGER

Amputation and thrown objects hazard



- Keep hands and feet away from deck.
- Do not operate mower unless discharge chute or entire grass catcher is in its proper place.



7101665

C Part No.: 5103184 - Warning, Hand in Belt, Eng Only

⚠ WARNING

Amputation and Pinch Point Hazard

To avoid injury from rotating parts, stay clear of parts and keep all shields and guards in place.



5103184

Safety Icons

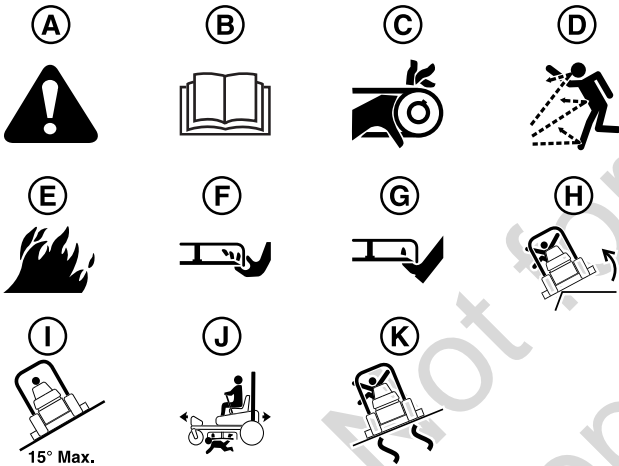

Callout	Description
A	Alert
B	Read the Manual
C	Amputation - Rotating Parts
D	Thrown Objects
E	Fire Hazard
F	Amputation - Hand in Blade
G	Amputation - Foot in Blade
H	Dropoffs
I	Maximum Slope Angle for Safe Operation
J	Keep Children Away
K	Slippery Slopes

Safety Icons for Optional Jack Kit Accessory

An optional jack kit is available as an accessory through your normal parts source. Please see the explanations below for the safety icons displayed on the jack kit.

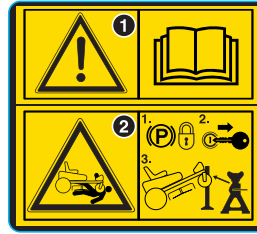

Part Number: 5105632 - Decal, Warnings, Svc Jack

1.) Warning - Read the Operator's Manual.

2.) **Crushing Hazard, Mower:** (1.) Park machine on flat level ground and engage the parking brake; (2.) Stop the engine and remove the ignition key; (3.) Properly jack the machine and secure with jack stands before working under the machine.

Safety Alert Symbol and Signal Words

The safety alert symbol (⚠) is used to identify safety information about hazards that can result in personal injury. A signal word (DANGER, WARNING, or CAUTION) is used with the alert symbol to indicate the likelihood and the potential severity of injury. In addition, a hazard symbol may be used to represent the type of hazard.

⚠ DANGER indicates a hazard which, if not avoided, **will result in death or serious injury.**

⚠ WARNING indicates a hazard which, if not avoided, **could result in death or serious injury.**

⚠ CAUTION indicates a hazard which, if not avoided, **could result in minor or moderate injury.**

NOTICE indicates a situation that **could result in damage to the product.**

Safety Interlock System

This unit is equipped with safety interlock switches. These safety systems are present for your safety, do not attempt to bypass safety switches, and never tamper with safety devices. Check their operation regularly.

Operational SAFETY Checks

Test 1 - Engine SHOULD NOT crank if:

- PTO switch is engaged, OR
- Parking brake is not engaged.

Test 2 - Engine SHOULD crank if:

- PTO switch is not engaged, AND
- Parking brake is engaged.

Test 3 - Engine should SHUT OFF if:

- Operator rises off seat with PTO engaged, OR
- Operator rises off seat with parking brake disengaged.

Test 4 - Blade Brake Check

Mower blades and mower drive belt should come to a complete stop within seven (7) seconds after electric PTO switch is turned off (or operator rises off seat). If mower drive belt does not stop within seven (7) seconds, see your dealer.

NOTE: Once the engine has stopped, PTO switch must be turned off, parking brake must be engaged, and the ground speed control levers must be locked in the NEUTRAL position after the operator returns to the seat in order to start the engine.



WARNING

If the unit does not pass a safety test, do not operate it. See your authorized dealer. Under no circumstance should you attempt to defeat the purpose of safety interlock system.

Features and Controls

Control Functions and Locations

The information below briefly describes the function of individual controls. Starting, stopping, driving, and mowing require the combined use of several controls applied in specific sequences. To learn what combination and sequence of controls to use for various tasks see the *Operation* section.

Zero-Turn Rider Controls

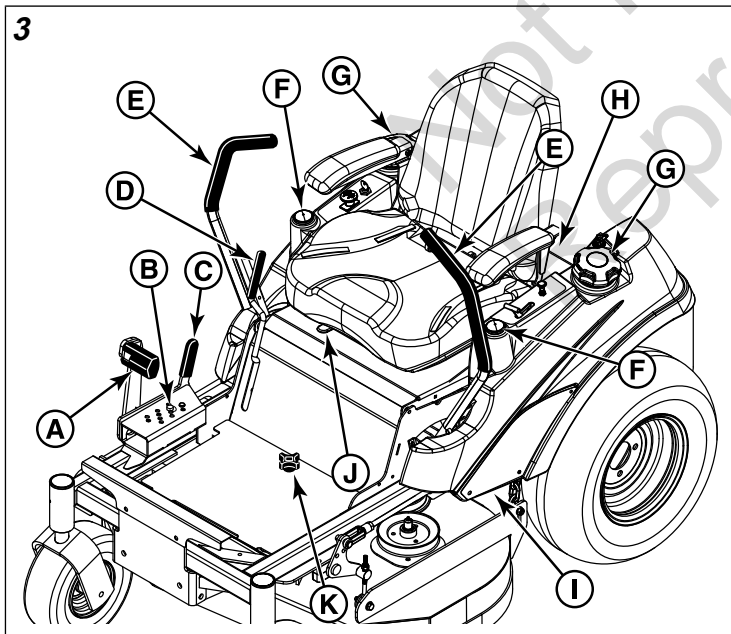

Zero-Turn Rider Controls	
Callout	Control Name
A	Deck Lift Pedal
B	Cutting Height Adjustment Pin
C	Deck Lift Lock Lever

Zero-Turn Rider Controls	
D	Parking Brake
E	Ground Speed Control Levers
F	Fuel Level Gauge (One per fuel tank)
G	Fuel Tank Cap (One per fuel tank)
H	Transmission Oil Fill / Tanks (One per transmission)
I	Transmission Release Levers (One per transmission)
J	Seat Adjustment Lever
K	Removable Floor Plate

Deck Lift Pedal, Cutting Height Adjustment Pin & Deck Lift Lock Lever:

The deck lift pedal (A, Figure 4), the cutting height adjustment pin (B) and the deck lift lock lever (C) are used together to control the cutting height of the mower deck. See *Cutting Height Adjustment* for instructions on using these controls.

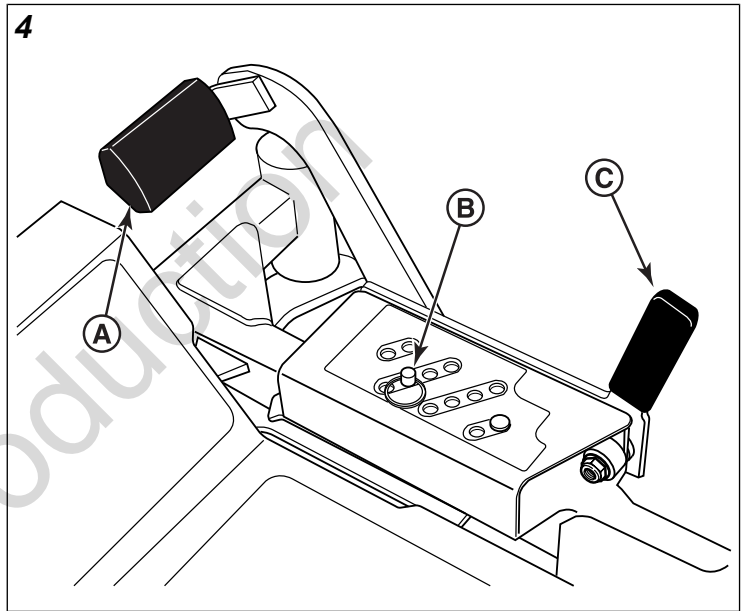

	Cutting Height Adjustment Pin
	Deck Lift Lock Lever

(P) Parking Brake: Pull the parking brake lever up and back to engage the parking brake. Move the lever fully forward and down to disengage the parking brake.

Note: To start the unit the parking brake must be engaged.



Engaging the parking brake locks the ground speed control levers in the NEUTRAL position. The parking brake must be disengaged before moving the ground speed control levers out of the NEUTRAL position.

	Disengage	Releases the parking brake.
--	-----------	-----------------------------

	Engage	Locks the parking brake.
---	--------	--------------------------

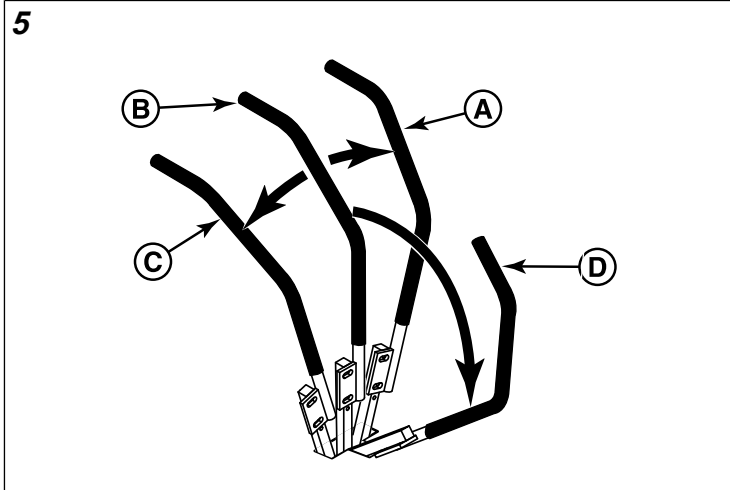
Ground Speed Control Levers: These levers control the ground speed and direction of the rider. The left lever controls the left rear drive wheel and the right lever controls the right rear drive wheel.



Callout	Icon	Description
A		FORWARD
B		NEUTRAL
C		REVERSE
D	N/A	NEUTRAL LOCKOUT POSITION

The parking brake must be disengaged before attempting to move the ground speed control levers from the NEUTRAL position.

Moving a lever forward (A) from the NEUTRAL position (B) increases the FORWARD speed of the associated wheel, and pulling back (C) on a lever increases the REVERSE speed.

Moving a levers outwards (D) from the NEUTRAL position locks the levers in the NEUTRAL LOCKOUT position.

Note: The further a lever is moved away from the neutral position the faster the drive wheel will turn.

See the *Zero-Turn Driving Practice* section for steering instructions.

Fuel Tank Cap: To remove the cap, turn **counter-clockwise**.



Fuel Level Gauge: Displays the fuel level in the tank.

Transmission Release Levers:

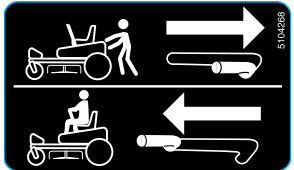
Icon	Control Name
	Transmission Release Levers

This unit is equipped with two transmission release levers. The transmission release levers deactivate the transaxle so that the unit can be pushed by hand. Both transmission release levers must be in the same position whether you are driving the unit or pushing it by hand. See *Pushing the Unit by Hand* for operational information.

Transmission Oil Fill: Transmission oil is added through the hydraulic oil tanks. It also serves as extra holding capacity for oil as the transmissions heat up and the hydraulic oil expands. See *Check / Fill Transmission Oil* for oil level check and fill procedures.

Seat Adjustment Lever: The seat can be adjusted forward and back. Move the lever towards the left, position the seat as desired, and release the lever to lock the seat in position.

Removable Floor Plate: The floor plate can be removed for easy access to the mower deck. To remove the plate, remove the retainer hardware and tilt the floor pan up and then remove from the machine. Reverse the process for re-installation.

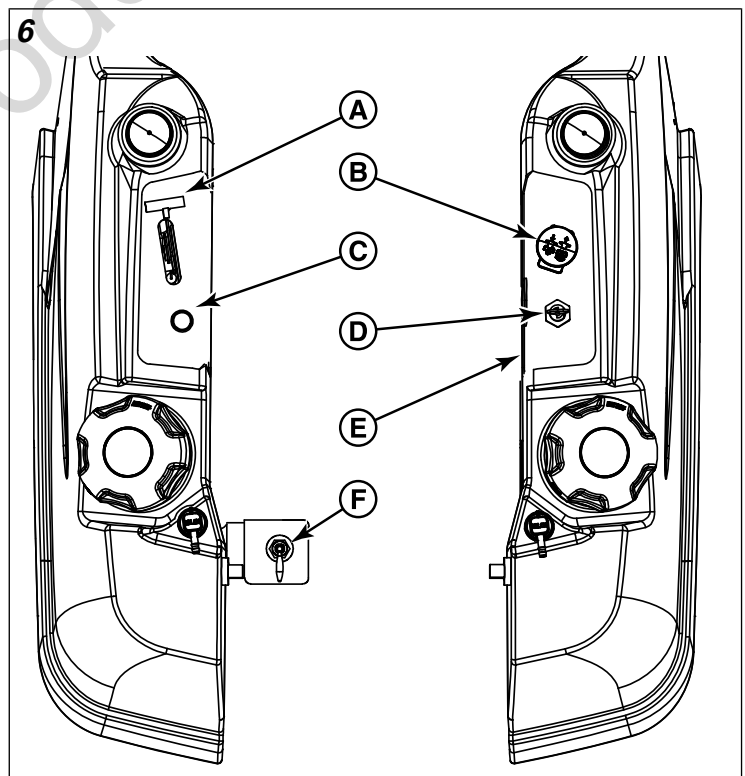

Instrument Control Panels





Instrument Control Panels	
Callout	Description
A	Fuel Level Gauge
B	Transmission Release Lever
C	Transmission Release Lever
D	Seat Adjustment Lever
E	Fuel Tank Cap
F	Fuel Tank Cap

Instrument Control Panels	
A	Throttle Control
B	PTO (Power Take Off) Switch
C	Choke
D	Ignition Switch
E	Hour Meter
F	Fuel Selector Valve



Throttle Control: The throttle controls engine speed. Move the throttle forward to increase engine speed and back to decrease engine speed. Always operate at FULL throttle when mowing.

	Fast throttle speed.
	Slow throttle speed.

 **PTO (Power Take Off) Switch:** The PTO switch engages and disengages the mower blades. Pull UP on the switch to engage, and push DOWN to disengage.

 **Choke:** Close the choke for cold starting. Open the choke once the engine starts. A warm engine may not require choking. Pull the knob UP to close the choke. Push the knob DOWN to open the choke.

Ignition Switch: The ignition switch starts and stops the engine, it has three positions:

	OFF	Stops the engine and shuts off the electrical system.
	RUN	Allows the engine to run and powers the electrical system.
	START	Cranks the engine for starting.

NOTE: Never leave the ignition switch in the RUN position with the engine stopped—this drains the battery.

Your machine is equipped with one of the different styles of hour meter listed below.

Hour Meter (Displays Numbers Only): The hour meter measures the number of hours that the engine has run. The hour meter has a self contained power source so the total hours are always visible.

Hour Meter (Displays Numbers and Letters): This unit is equipped with a dual function hour meter that records the number of hours that the engine has run and the number of hours that the PTO switch has been engaged.

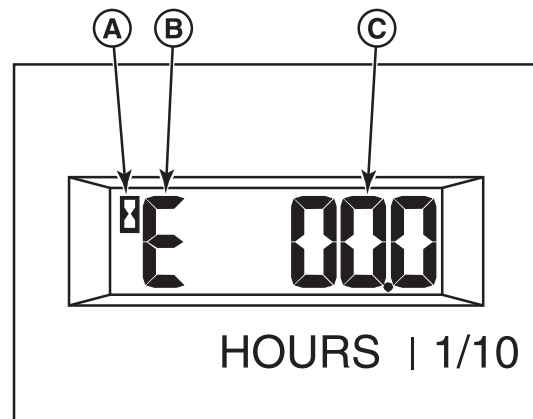

"A" - Hour Glass Icon - The hour glass icon flashes when the hour meter is recording the passage of time.

"B" - Mode Icon - The mode icon will display an "E" when displaying engine hours, and a "P" when displaying PTO hours.

"C" - Time Display - This is the number of hours that are recorded.

The default display of the hour meter is engine hours. The mode icon will display a "E" and the hour glass icon will not flash.

To begin recording engine hours, start the unit's engine and release the parking brake. The hour glass icon will flash.

To begin recording PTO hours, pull the PTO switch up to engage the PTO clutch. The unit's engine must be running. The mode icon will display a "P" and the hour glass icon will flash.

While recording PTO hours, the hour meter also records engine hours; however, the hour meter only displays PTO hours when recording PTO hours.

To stop recording PTO hours, push the PTO switch down to disengage the PTO clutch.

To stop recording engine hours, engage the parking brake.

The hour meter has a self contained power source so that the recorded hours are always visible even when the engine is OFF.

Fuel Selector Valve: Turning the handle to the desired position determines which tank will be supplying fuel. With the handle pointing LEFT, it will draw fuel from the left-hand tank. With the handle pointing RIGHT, it will draw fuel from the right-hand fuel tank. With the handle pointing towards the operator, it will shut off fuel flow to the engine.

Operation

Before First Time Operation

- Be sure to read all information in the Safety and Operation sections before attempting to operate this tractor and mower.
- Become familiar with all of the controls and how to stop the unit.
- Drive in an open area without mowing to become accustomed to the unit.



WARNING

- Never operate on slopes greater than 15°.
- Select slow ground speed before driving onto a slope. Use extra caution when operating on slopes with a rear-mounted grass catcher.
- Mow across the face of slopes, not up and down, use caution when changing direction on slopes and **do NOT start or stop on a slope.**



WARNING

- Never allow passengers to ride on the unit.
- Before leaving the operator's position for any reason, engage the parking brake, disengage the PTO, stop the engine and remove the key.
- To reduce fire hazard, keep the engine, rider and mower free of grass, leaves and excess grease. Do NOT stop or park rider over dry leaves, grass or combustible materials.
- Fuel is highly flammable and must be handled with care. Never fill the tank when the engine is still hot from recent operation. Do NOT allow open flame, smoking or matches in the area. Avoid over-filling and wipe up any spills.



WARNING

Do NOT load this zero-turn rider on a trailer or truck using two separate ramps. Only use a single ramp that is at least one foot wider than the width of the rear wheels of this rider. This rider has a zero turning radius and the rear wheels could fall off the ramps, or the rider could tip over injuring the operator or bystanders.

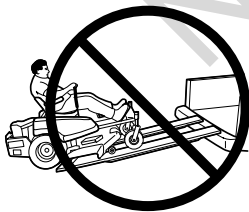

Checks Before Starting

- Check that the crankcase is filled to the full mark on the crankcase oil fill and dipstick. If necessary, add oil through the engine oil fill. See the engine Operator's manual for instructions, engine oil dipstick location and oil recommendations.
- Make sure all nuts, bolts, screws and pins are in place and tight.
- Adjust the seat position, and make certain you can reach all the controls from operator's position.
- Fill the fuel tank with fresh fuel. Refer to engine manual for fuel recommendations.

- Check the hydraulic oil level.
- **Models with two fuel tanks:** Make sure that the fuel selector valve is in an "ON" position.

Starting the Engine



WARNING

- If you do not understand how a specific control functions, or have not yet thoroughly read the *Features & Controls* section, do so now.
 - Do NOT attempt to operate the tractor without first becoming familiar with the location and function of all controls.
1. While sitting in the operator's seat, engage the parking brake and make sure the PTO switch is disengaged and the ground speed control levers are locked in the neutral position.
 2. **A warm engine may not require choking.** Set the engine throttle control to FAST throttle position. Then fully close the choke by pulling the knob OUT fully.
 3. Insert the key into the ignition switch and turn it to START.
 4. After the engine starts, gradually open the choke (push knob down fully). Reduce to half throttle speed and allow engine to warm. *Warm up the engine by running it for at least a minute before engaging the PTO switch or driving the rider.*
 5. After warming the engine always operate the unit at FULL throttle when mowing.

In the event of an emergency the engine can be stopped by simply turning the ignition switch to STOP. Use this method only in emergency situations. For normal engine shut down follow the procedure given in *Stopping the Rider.*

Stopping the Rider

1. Returning the ground speed control levers to the middle position will stop rider movement. Pivot the levers outward and lock them in NEUTRAL.
2. Disengage the PTO by pushing down on the PTO switch.
3. Engage the parking brake by pulling the handle up until it locks into position.
4. Move the throttle control to mid-throttle position and turn the ignition key to OFF. Remove the key.

Zero-Turn Driving Practice

The lever controls of the Zero Turn rider are responsive, and learning to gain a smooth and efficient control of the rider's forward, reverse, and turning movements will take some practice.

Spending some time going through the maneuvers shown and becoming familiar with how the unit accelerates, travels, and

steers — before you begin mowing — is absolutely essential to getting the most out of the Zero Turn rider.

Locate a smooth, flat area of your lawn — one with plenty of room to maneuver. (Clear the area of objects, people and animals before you begin.) Operate the unit at mid-throttle during this practice session (ALWAYS operate at full throttle when mowing), and turn slowly to prevent tire slippage and damage to your lawn.

We suggest you begin with the Smooth Travel procedure to the right, and then advance through the forward, reverse, and turning maneuvers.

You must release the parking brake prior to moving the control levers inward.

Smooth Travel

The lever controls of the Zero Turn rider are responsive.

The BEST method of handling the ground speed control levers is in three steps — as shown in Figure 7.

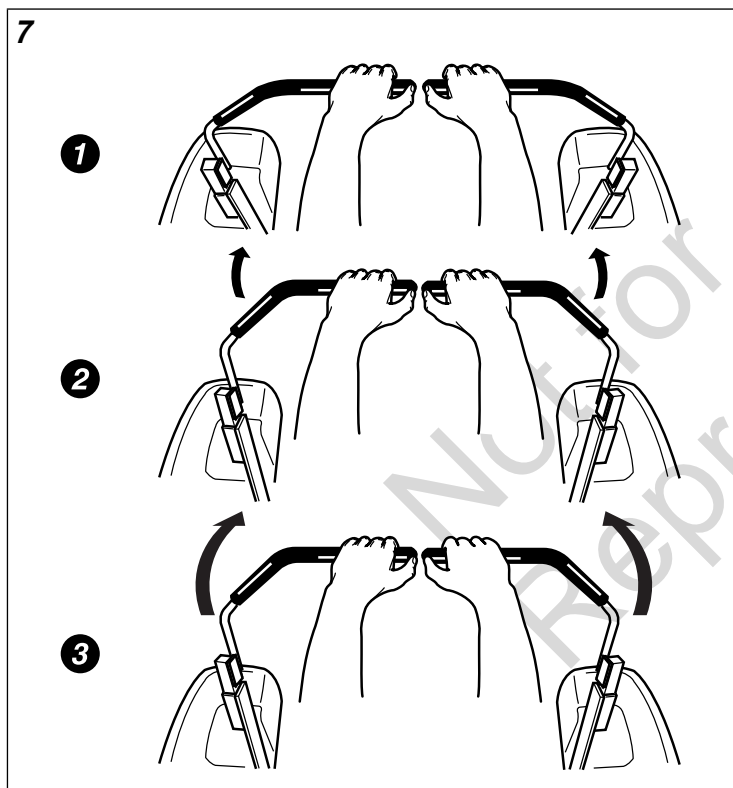

FIRST place your hands onto the levers as shown.

SECOND, to go forward gradually push the levers forward with your palms.

THIRD, to speed up move the levers farther forward. To slow down smoothly, slowly move the levers toward neutral.

Basic Driving

Forward Travel Practice

8

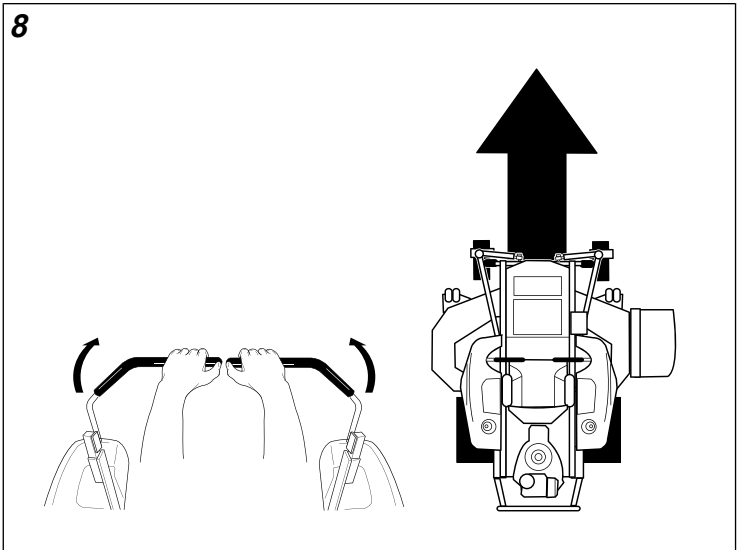

Gradually move both ground speed control levers — evenly FORWARD from neutral. Slow down and repeat.

NOTE: Straight forward travel takes practice. If necessary, top speed can be balance-adjusted — see the Speed Balancing Adjustment in the Adjustments section near the back of this manual.

Reverse Travel Practice

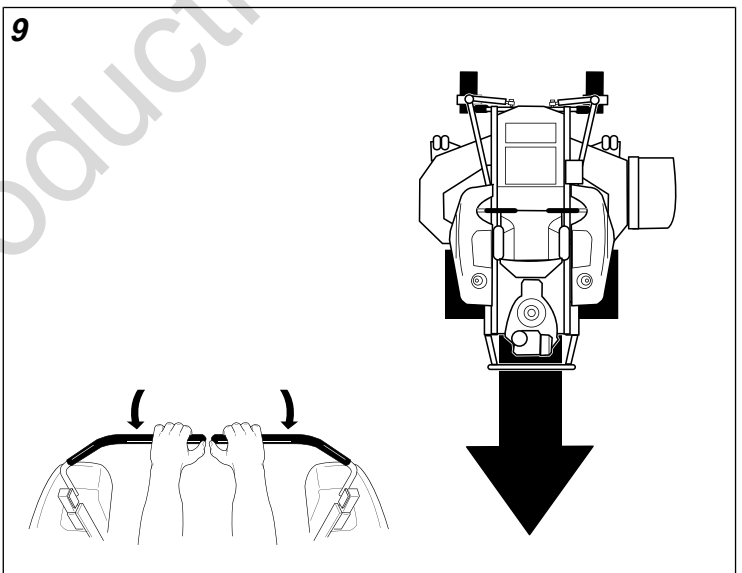

LOOK DOWN & BEHIND, then gradually move both ground speed control levers evenly BACK from neutral. Slow down and repeat.

NOTE: Practice backing up for several minutes before attempting to do so near objects. The rider turns sharply in reverse as well as forward, and backing up straight takes practice.

Practice Turning Around A Corner

10

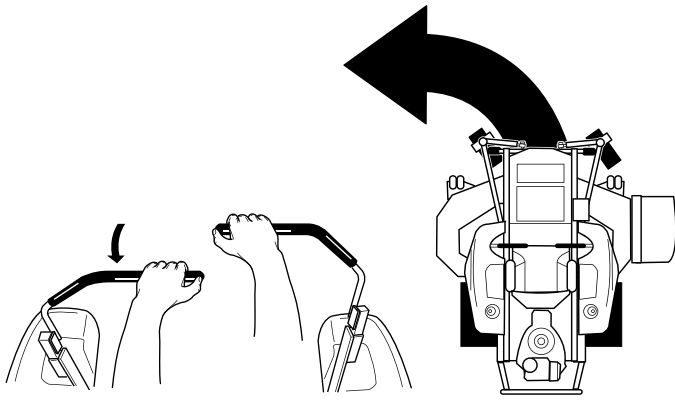

While traveling forward allow one handle to gradually return back toward neutral. Repeat several times.

NOTE: To prevent pivoting directly on the tire tread, it is best to keep both wheels going at least slightly forward.

Practice Turning in Place

11

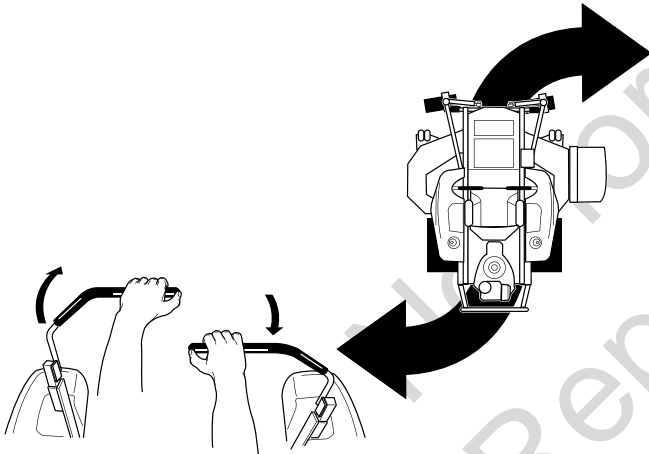

To turn in place, "Zero Turn," gradually move one ground speed control lever forward from neutral and one lever back from neutral simultaneously. Repeat several times.

NOTE: Changing the amount each lever is pulled—forward or back, changes the "pivot point" you turn on.

Advanced Driving

Executing an End-Of-Row Zero Turn

12

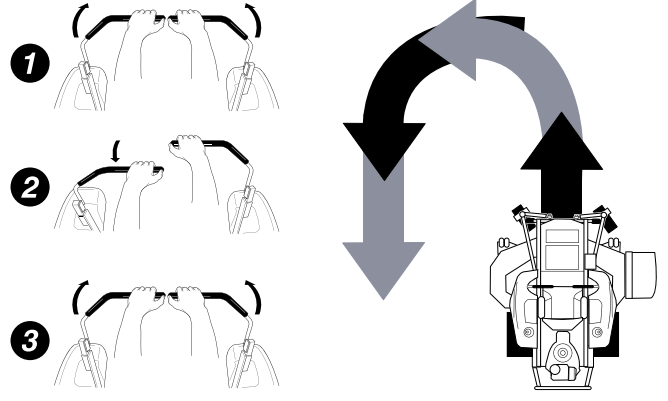

Your Zero Turn Rider's unique ability to turn in place allows you to turn around at the end of a cutting row rather than having to stop and Y-turn before starting a new row.

For example, to execute a left end-of row zero turn:

1. Slow down at the end of the row.
2. Move the RIGHT ground speed control lever forward slightly while moving the LEFT ground speed control lever back to center and then slightly back from center.
3. Begin mowing forward again.

This technique turns the rider LEFT and slightly overlaps the row just cut—eliminating the need to back up and re-cut missed grass.

As you become more familiar and experienced with operating the Zero Turn rider, you will learn more maneuvers that will make your mowing time easier and more enjoyable.

Remember, the more you practice, the better your control of the Zero Turn will be!

Mowing

1. Engage the parking brake. Make sure that the PTO switch is disengaged, the ground speed control levers are locked in the NEUTRAL position and the operator is in the seat.
2. Start the engine. See *Starting the Engine*.
3. Set the mower cutting height.
4. Set the throttle to the 1/2 throttle position.

Note: It is best practice to engage the PTO with the throttle set at the minimum throttle position necessary to engage the deck drive system without stalling the engine.

5. Engage the PTO by pulling up on the PTO switch.
6. Move the throttle to the "FAST" position and begin mowing.
7. When finished, reduce throttle speed so that the engine idles and push the PTO switch down to shut off the PTO.
8. Stop the engine. See *Stopping the Rider*.

Mowing Recommendations

Several factors can affect how well your machine cuts grass. Following proper mowing recommendations can improve the performance and life of your machine.

Height of Grass

Often cutting height is a matter of personal preference. Typically, you should mow the grass when it is between three and five inches high. The proper cutting height range for a specific lawn will depend upon several factors, including the type of grass, the amount of rainfall, the prevailing temperature, and the lawn's overall condition.

Cutting the grass too short causes weak, thin grass plants, which are easily damaged by dry periods and pests. Cutting too short is often more damaging than allowing the grass to be slightly higher.

Letting grass grow a bit longer—especially when it is hot and dry—reduces heat build-up, preserves needed moisture and protects the grass from heat damage and other problems. However, allowing grass to grow too high can cause thin turf and additional problems.

Cutting off too much at one time shocks the plant's growth system and weakens the grass plants. **A good rule of thumb is the 1/3 rule: to cut no more than one third of the grass height, and never more than 1 inch at a time.**

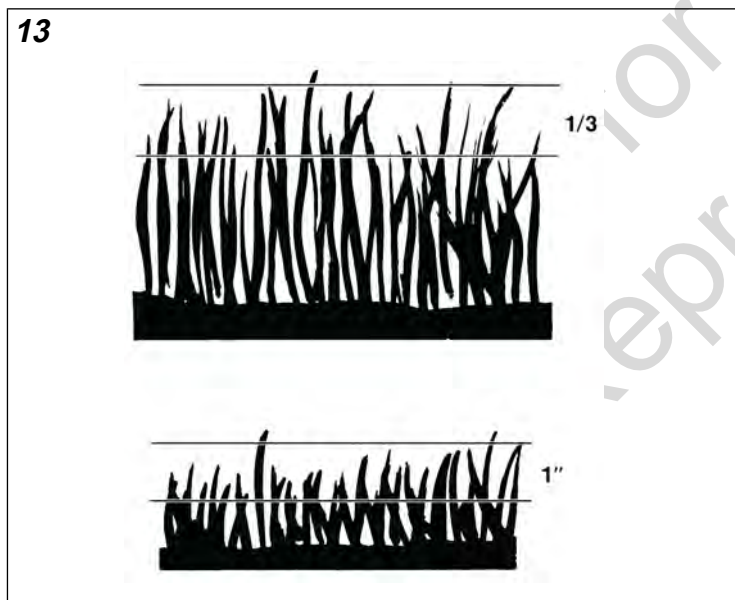

The amount of grass you are able to cut in one pass is also effected by the type of mowing system you are using (for example, broadcasting with side discharge decks can process a much larger volume of grass than mulching does).

Tall grass requires incremental cutting. For extremely tall grass, set the cutting height at maximum for the first pass (A, Figure 14), and then reset it to the desired height and mow a second (B) or third time.

Don't cover the grass surface with a heavy layer of clippings. Consider using a grass collection system and starting a compost pile.

14

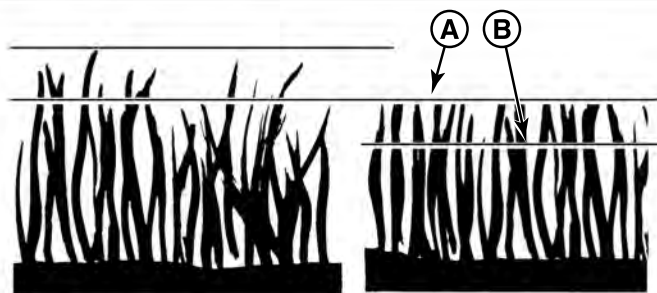

When and How Often to Mow

The time of day and condition of the grass greatly affect the results you'll get when mowing. For the best results, follow these guidelines:

- Mow when the grass is between three and five inches high.
- Mow with sharp blades. Short clippings of grass one inch or shorter decompose more quickly than longer blades. Sharp mower blades cut grass cleanly and efficiently, preventing frayed edges which harm the grass.
- Mow at time of day when the grass is cool and dry. Late afternoon or early evening often provide these ideal mowing conditions.
- Avoid mowing after rain or even heavy dew, and never mulch when the grass is wet (moist grass does not mulch well, and clumps beneath the mower deck).

Mowing Patterns

Always start mowing on a smooth, level area.

The size and type of area to be mowed will determine the best mowing pattern to use. Obstructions such as trees, fences and buildings, and conditions such as slopes and grades must also be considered.

- Cut long straight strips overlapping slightly.
- Where possible, change patterns occasionally to eliminate matting, graining or a corrugated appearance.
- For a truly professional cut, mow across the lawn in one direction, then re-cut the lawn by mowing perpendicular to the previous cut.

Note: Always operate the engine at FULL THROTTLE when mowing.

If you hear the engine slowing down, you are mowing too fast—using a slower ground speed will improve the cutting efficiency of the blades and prevents many common cutting problems. Use an appropriate ground speed for the thickness and height of the grass you are cutting (3rd gear or slower for manual gear models). If you hear the engine slowing down you are mowing too fast, use a slower ground speed.

15

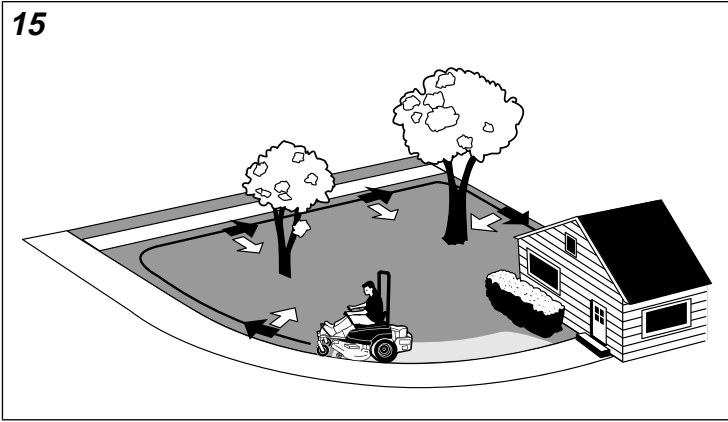

Where possible, make one or two passes around the outside of the area discharging the grass INTO the lawn to keep the cut grass off fences and walks.

16

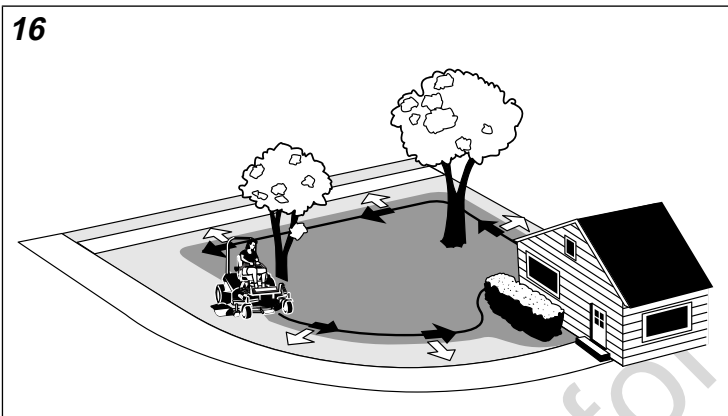

The remainder of the mowing should be done in the opposite direction so that the clippings are dispersed OUT onto the area of lawn previously cut.

Mowing Methods

Broadcast Mowing

Broadcasting, or side-discharging, disperses fine clippings evenly over the entire lawn. Many golf courses use this method. Your mower has a deep dish deck to allow freer circulation of clippings so they are broadcast evenly over the lawn.

Engine Speed & Ground Speed for Broadcasting:

Always operate the engine at full throttle when mowing. If you hear the engine slowing down, you are mowing too fast—using a slower ground speed will improve the cutting efficiency of the blades and prevents many common cutting problems.

ALWAYS use an appropriate ground speed for the thickness and height of the grass you are cutting (3rd gear or slower for manual gear models). If you hear the engine slowing down you are mowing too fast, use a slower ground speed.

How Much Grass to Cut Off When Broadcasting:

Mow when the grass is 3-5 inches long. Do not cut the grass shorter than 2 to 2-1/2 inches. Do not cut off more than 1 inch of grass in a single pass.

Mulching

Mulching consists of a mower deck which cuts and re-cuts clippings into tiny particles and which then blows them down INTO the lawn. These tiny particles decompose rapidly into by-products your lawn can use. UNDER PROPER CONDITIONS, your mulching mower will virtually eliminate noticeable clippings on the lawn surface.

Note: When mulching under heavy cutting conditions, a rumbling sound may be present and is normal.

Mulching Requires EXCELLENT Mowing Conditions:

Mulching mowers cannot function properly if the grass is wet, or if the grass is simply too high to cut. Even more than normal mowing, mulching requires that the grass be dry and the appropriate amount is cut.

Do not use the mower as a mulching mower during the first two or three mowings in the spring. The long grass blades, quick growth, and often wetter conditions are more suitable for broadcasting (side-discharging) or grass bagging operation.

Engine Speed & Ground Speed for Mulching:

Use full engine throttle matched with a slow ground speed so that clippings will be finely cut. Ground speed while mulching should be HALF of the speed that would be used when broadcasting (side discharging) under similar conditions. Since mulching requires more horsepower than broadcasting, using a slower ground speed is vitally important for proper mulching operation.

How Much Grass to Mulch:

The best mulching action typically results from cutting only the top 1/2 inch to 3/4 inch of grass blade. This provides short clippings which decompose properly (much more quickly than longer clippings). The ideal cutting height will vary with climate, time of year, and quality of your lawn. We recommend that you experiment with both the cutting height and ground speed until you achieve the best cut. Start with a high cutting height and using progressively lower settings until you find a cutting height that is matched to your mowing conditions and preferences.

Pushing the Unit by Hand

NOTICE

Do NOT tow rider.

Towing the units will cause transmission damage. Do not use another vehicle to push or pull this unit.

1. Park the machine on a flat, level surface such as a concrete floor. Disengage the PTO, engage the parking brake, turn the ignition OFF, and remove the key.
2. Locate the transmission release levers (A, Figure 17) located underneath the front of the fuel tanks. There is one transmission release lever on each transmission. The transmission release levers open and close the transmission bypass valves.

17

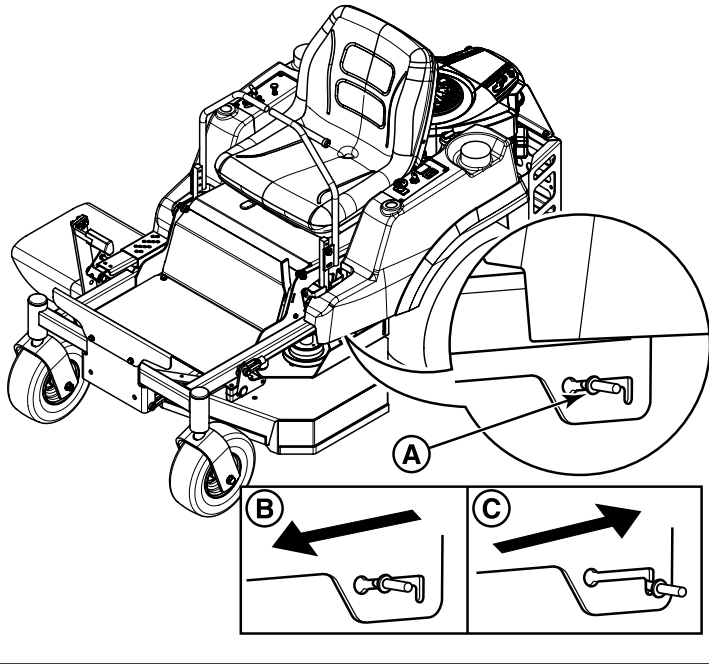

3. To open the transmission bypass valve (bypass position) (C), pull the transmission release lever back and down so that it locks in the bypass position. Repeat the process for the other side of the unit.
4. Disengage the parking brake. The unit can now be pushed by hand.
5. After moving the unit, close the bypass valve (run position) (B) by pulling the transmission release lever up and pushing them forward to the front of the machine. Repeat the process for the other side of the unit.

Note: Both transmission release levers must be in the same position.

Attaching a Trailer

The maximum weight of a towed trailer should be less than 200 lbs (91kg). Secure the trailer with an appropriately sized clevis pin (A, Figure 18) and clip (B).

18

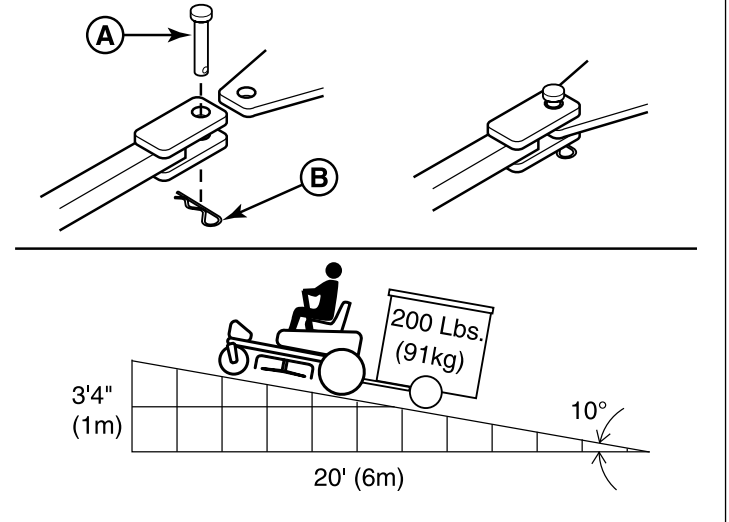

Excessive towed loads can cause loss of traction and loss of control on slopes. Reduce towed weight when operating on slopes. The surface being driven on greatly impacts traction and stability. Wet or slippery surfaces can greatly reduce traction and the ability to stop or turn. Carefully evaluate the surface conditions before operating the unit and trailer, and never operate on slopes greater than 10°. See SLOPE OPERATION and TOWED EQUIPMENT in the safety section of this manual for additional safety information.

Storage

Temporary Storage (30 Days or Less)

Remember, the fuel tank will still contain some gasoline, so never store the unit indoors or in any other area where fuel vapor could travel to any ignition source. Fuel vapor is also toxic if inhaled, so never store the unit in any structure used for human or animal habitation.



WARNING

Never store the unit, with gasoline in engine or fuel tank, in a heated shelter or in enclosed, poorly ventilated enclosures. Gasoline fumes may reach an open flame, spark or pilot light (such as a furnace, water heater, clothes dryer, etc.) and cause an explosion.

Handle gasoline carefully. It is highly flammable and careless use could result in serious fire damage to your person or property.

Drain fuel into an approved container outdoors away from open flame or sparks.

Here is a checklist of things to do when storing your unit temporarily or in between uses:

- Keep the unit in an area away from where children may come into contact with it. If there's any chance of unauthorized use, remove the spark plug (s) and put in a safe place. Be sure the spark plug opening is protected from foreign objects with a suitable cover.

- If the unit can't be stored on a reasonable level surface, chock the wheels.
- Clean all grass and dirt from the mower.

Long Term Storage (Longer Than 30 Days)

Before you store your unit for the off-season, read the Maintenance and Storage instructions in the Safety Rules section, then perform the following steps:

1. Drain crankcase oil while engine is hot and refill with a grade of oil that will be required when unit is used again.
2. Prepare the mower deck for storage as follows:
 - a.) Remove mower deck from the unit.
 - b.) Clean underside of mower deck.
 - c.) Coat all bare metal surfaces with paint or light coat of oil to prevent rusting.
3. Clean external surfaces and engine.
4. Prepare engine for storage. See engine owner's manual.
5. Clean any dirt or grass from cylinder head cooling fins, engine housing and air cleaner element.
6. Cover air cleaner and exhaust outlet tightly with plastic or other waterproof material to keep out moisture, dirt and insects.
7. Completely grease and oil unit as outlined in the *Lubrication* section.
8. Clean up unit and apply paint or rust preventative to any areas where paint is chipped or damaged.
9. Be sure the battery is filled to the proper level with water and is fully charged. Battery life will be increased if it is removed, put in a cool, dry place and fully charged about once a month. If battery is left in unit, disconnect the negative cable.
10. Drain fuel system completely or add a gasoline stabilizer to the fuel system. If you have chosen to use a fuel stabilizer and have not drained the fuel system, follow all safety instructions and storage precautions in this manual to prevent the possibility of fire from the ignition of gasoline fumes. Remember, gasoline fumes can travel to distant sources of ignition and ignite, causing risk of explosion and fire.

NOTE: Gasoline, if permitted to stand unused for extended periods (30 days or more), may develop gummy deposits which can adversely affect the engine carburetor and cause engine malfunction. To avoid this condition, add a gasoline stabilizer to the fuel tank and run the engine a few minutes, or drain all fuel from the unit before placing it in storage.

Starting After Long Term Storage

Before starting the unit after it has been stored for a long period of time, perform the following steps.

1. Remove any blocks from under the unit.
2. Install the battery if it was removed.
3. Unplug the exhaust outlet and air cleaner.

4. Fill the fuel tank with fresh gasoline. See engine manual for recommendations.
5. See engine owner's manual and follow all instructions for preparing engine after storage.
6. Check crankcase oil level and add proper oil if necessary. If any condensation has developed during storage, drain crankcase oil and refill.
7. Inflate tires to proper pressure. Check fluid levels.
8. Start the engine and let it run slowly. DO NOT run at high speed immediately after starting. Be sure to run engine only outdoors or in well ventilated area.

Maintenance Schedule

The following schedule should be followed for normal care of your unit. You will need to keep a record of your operating time. Determining operating time is easily accomplished by observing the hour meter.

If your unit is equipped with a dual function hour meter that displays both engine hours and PTO hours, the maintenance intervals are based on the engine hours as displayed by the hour meter.

UNIT MAINTENANCE	
Before Each Use	
	Check Safety Interlock System
	Check Rider Brakes
	Check Rider / Mower for Loose Hardware
	Check Hydraulic Oil Level
Every 25 Hours	
	Clean Deck & Check/Replace Mower Blades*
	Lubricate Rider & Mower*
	Check Tire Pressures
Every 100 Hours	
	Check Mower Blade Stopping Time
	Clean Battery & Cables
	Initial Change of Hydraulic Oil
Every 400 Hours or Yearly	
	Change Hydraulic Oil & Filter

ENGINE MAINTENANCE	
Before Each Use	
	Check Engine Oil Level
Every 25 Hours	
	Check/Clean Cooling Fins & Intake*
Every 50 Hours	
	Check/Clean Spark Arrester**
Refer to Engine Owner's Manual	
	Service Air Filter
	Change Oil & Filter
	Check/Replace Spark Plugs
	Check/Replace Fuel Filter

*More often in hot (over 85°F, 30°C) weather or dusty operating conditions.

**If equipped, replace if damaged.

Maintenance Procedures

Service and Maintenance Safety



Amputation and crushing hazard

Specific steps must be taken in order to perform service and maintenance procedures safely.

Read and follow all the applicable safety and instructional messages in this manual.

Always disengage the mower blades, set the parking brake, turn the engine OFF, remove the ignition key, and wait for all movement to stop prior to performing service and maintenance procedures.

Always disconnect the spark plug wire(s) and fasten it away from the plug before beginning any maintenance or service procedures on order to prevent accidental ignition.

Checking / Adding Fuel



Gasoline is highly flammable and must be handled with care. Allow engine to cool for at least 3 minutes before refueling. Do not allow open flame, smoking or matches in the area. Avoid over-filling and wipe up any spills.

To add fuel:

1. Remove the fuel cap (A, Figure 19).

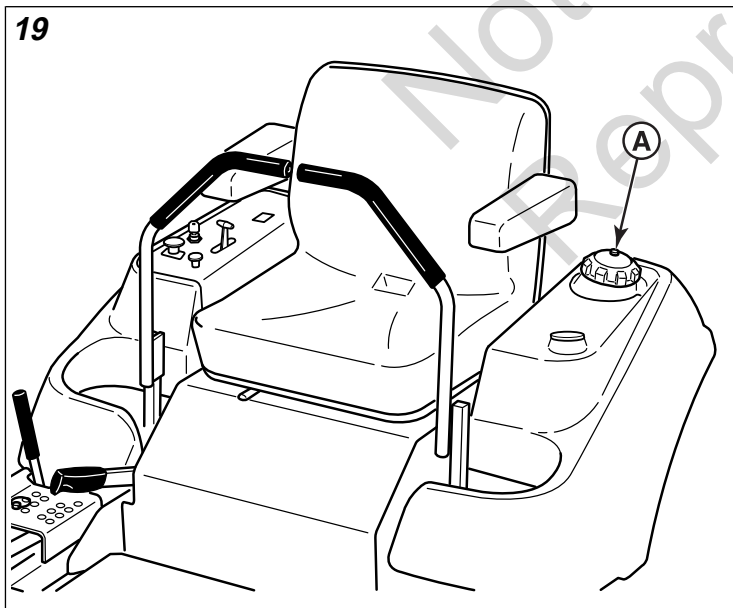

2. Fill the fuel tank to the bottom of the filler neck. This will allow for fuel expansion.
Note: Do not overfill. Refer to your engine owner's manual for specific fuel recommendations.
3. Install and hand tighten the fuel cap.

4. If your unit is equipped with two fuel tanks, repeat this process to fill the other fuel tank.

NOTICE

Refer to your engine owner's manual for specific fuel recommendations.

Replacing the Fuel Filter



Fuel and its vapors are extremely flammable and explosive.

Fire or explosion can cause severe burns or death.

Do NOT remove the fuel filter when the engine is hot, as spilled gasoline may ignite. Do NOT spread hose clamps further than necessary. Ensure clamps grip hoses firmly over filter after installation.

Carbureted Models: The fuel filter is located in the fuel line between fuel tank and carburetor, near the fuel pump.

Fuel Injected Models: The fuel filter is located in the fuel line between the fuel tank and fuel pump.

If filter is dirty or clogged, replace as follows:

1. Disconnect the negative battery cable.
2. Place a container below the filter to catch spilled fuel.
3. Using a pliers, open and slide hose clamps from fuel filter.
4. Remove hoses from filter.
5. Install new filter in proper flow direction in fuel line.
6. Secure with hose clamps.
7. Reconnect the negative battery cable when finished.

Check Engine Oil Level

Interval: Before Each Use

Refer to the engine owners manual for dipstick and oil fill locations and specific engine oil check and fill procedures.

Changing the Engine Oil and Filter

This series of mower has different engine options: Briggs & Stratton (A, Figure 20) and Kawasaki (B). Please reference figure 19 as the location of the components listed for this procedure may vary by specific engine option.

20

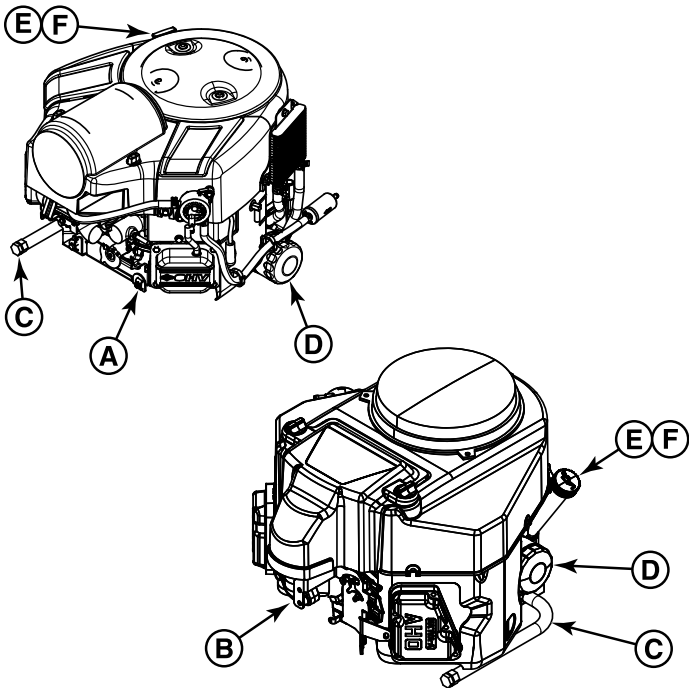

1. Warm engine by running for a few minutes. (Refer to the engine operator's manual for oil and filter replacement instructions.)
2. Remove the oil drain hose (C) from its storage position and route the hose so that when the oil drain cap is removed the oil can be drained into a small pan.
3. Place a small pan under the oil drain hose to catch the oil. Using the appropriate tools, remove the oil drain cap from the oil drain hose and drain the engine oil.
4. After draining, replace the cap and wipe up any spilled oil. Reinstall the oil drain hose to its storage position so it is retained during normal operation.
5. Place an absorbent shop cloth under the engine oil filter (D). Remove the engine oil filter and replace with a new one.
6. Add engine oil (refer to engine operator's manual) in the fill tube (E) and check the amount of oil in the engine using the engine oil dipstick (F).
7. Remove the shop cloth and wipe up any spilled oil.

Engine Maintenance

For engine maintenance schedules and procedures, please refer to the engine operator's manual.

Inspect Muffler and Spark Arrester

Inspect the muffler for cracks, corrosion, or other damage. Remove the spark arrester, if equipped, and inspect for damage or carbon blockage. If replacement parts are required, make sure to use only original equipment replacement parts.



WARNING

Replacement parts must be the same and installed in the same position as the original parts or fire could result.

Fuse Location and Identification

The electrical system for this unit is equipped with two replaceable fuses. See the chart below for the circuit, amperage, and approximate location of the fuses.

Circuit	Amperage	Approximate Location
Main	20 amp	Instrument control panel.
PTO Clutch	15 amp	Behind the seat on the left hand side of the machine.

Raising and Lowering the Seat Plate

This unit is equipped with a hinged seat plate that can be raised to access the components beneath it.

1. Raise the seat plate. The seat stop (A, Figure 21) will lock it open.

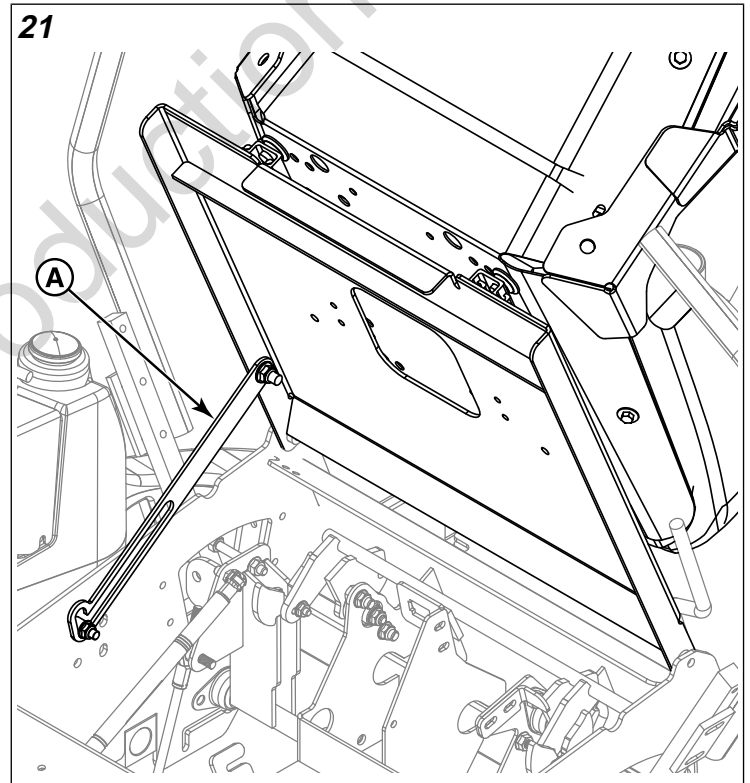

2. Raise the back end of the seat stop and lower the seat plate back into place.

Floor Pan Removal & Installation

This unit is equipped with a removable floor pan which can be removed to provide better access to the mower deck.

1. Loosen and remove the retaining hardware (A, Figure 22) that secures the floor pan to the frame of the unit.

22

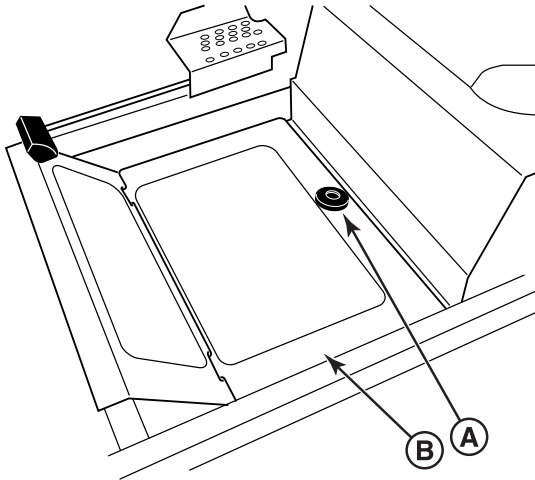

2. Tilt the back end of the floor pan up and then remove it from the unit.
3. To re-install the floor pan: Reverse the removal procedure.

Lubrication

Lubricate the unit at the locations shown in Figures 23, 24, and 25 as well as the following lubrication points.

Grease:



- front caster wheel axles & yokes
- deck lift pivot blocks
- mower deck spindles

Use grease fittings when present. Disassemble parts to apply grease to moving parts when grease fittings are not installed.

Not all greases are compatible. Red Grease (p/n 5022285) is recommended, automotive-type high-temperature, lithium grease may be used when this is not available.

Oil:



- control handle pivots
- seat plate pivots
- deck lift pivots
- discharge chute hinge

Generally, all moving metal parts should be oiled where contact is made with other parts. Keep oil and grease off belts and pulleys. Remember to wipe fittings and surfaces clean both before and after lubrication.

23

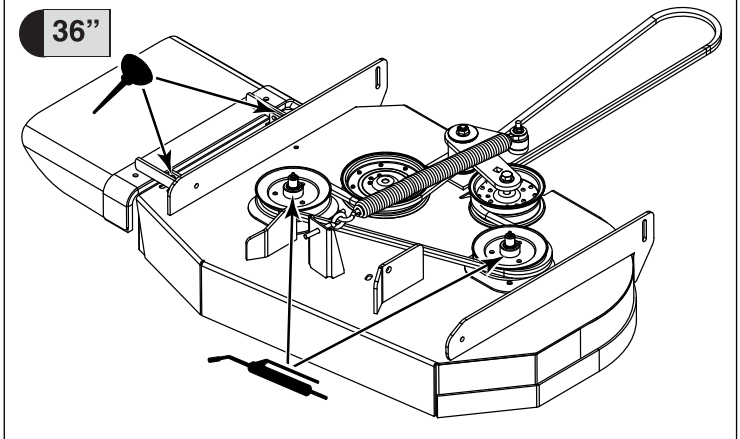

24

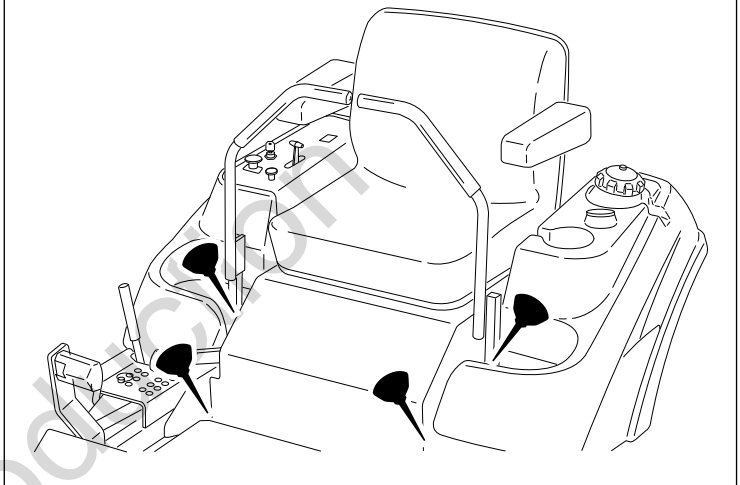

25

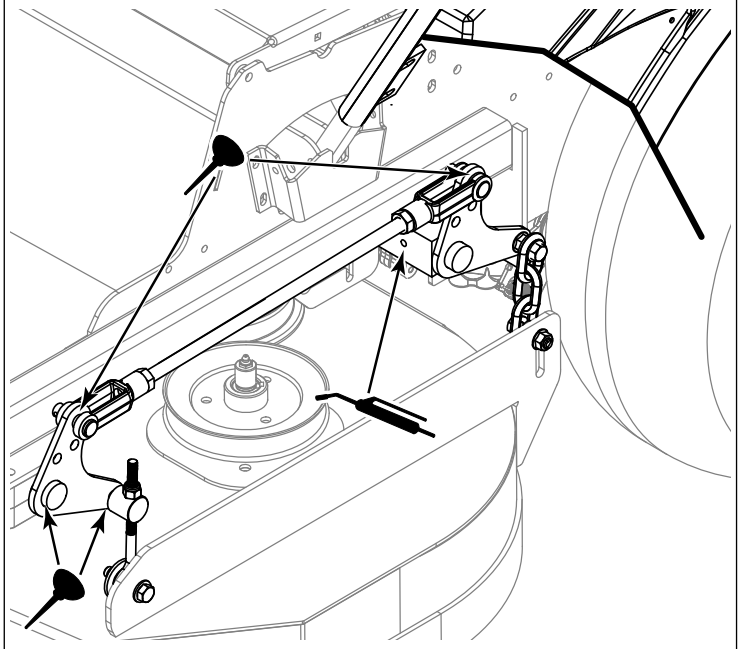

Lubricate the Front Casters

Interval: Annually

1. Remove the 1/4-28 bolt (A, Figure 26) screwed into the caster and install a 1/4-28 grease fitting.

26

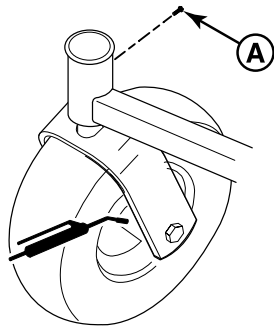

2. Grease the front caster.
3. Remove the 1/4-28 grease fitting and reinstall the 1/4-28 bolt.
4. Repeat the process for the other side of the machine.

Check / Fill Transmission Oil Level

This unit is equipped with two transmission oil tanks. One transmission oil tank supplies oil to one transmission. The level of oil in both transmission tanks must be checked, and if necessary, filled.

Oil Type: 20W-50 conventional detergent motor oil

1. Locate the transmission oil tanks (A, Figure 27) underneath the seat plate and in front of the engine.

27

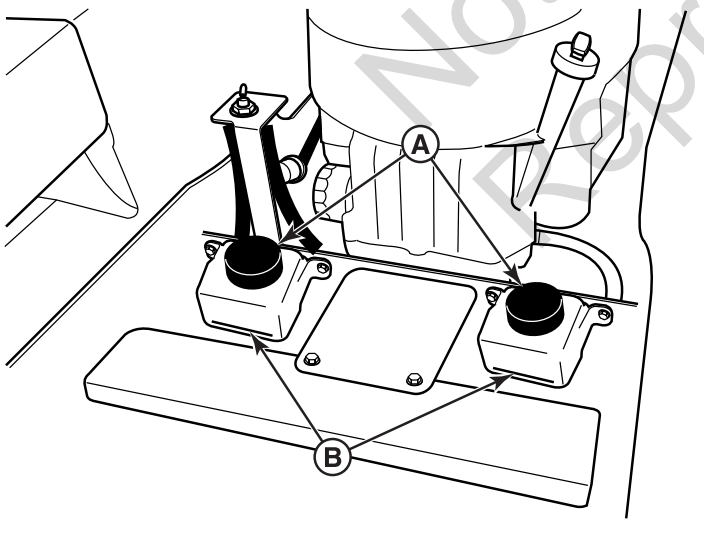

2. Check the oil level when the unit is cold. The oil should be up to the "FULL COLD" mark (B). If the oil is below this level, proceed to step #3.
3. Before removing the tank caps, make sure the area around the tank cap and fill neck of the tank is free of dust, dirt, and other debris. Remove the tank cap.

4. Add oil up to the "FULL COLD" mark.
5. Re-install the tank caps.
6. After adding oil to the tanks, it may be necessary to purge air from the hydraulic system. If the unit is not driving properly perform the *Purging the Air from the Hydraulic System* procedure.

Transmission Oil Filter Change

Change Interval: Every 400 Hours or Yearly (Initial hydraulic oil and filter change after first 100 hours of operation)

Replacement Filter Number: 5101026X1

Note: Removing the oil filter from the transaxle will drain the oil tank. Have a suitable container ready to catch any spilled oil. The manufacturer recommends that this be a dealer-only service item.

1. Locate the transmission oil filters (A, Figure 28) underneath the rear of the machine on the transmissions.

28

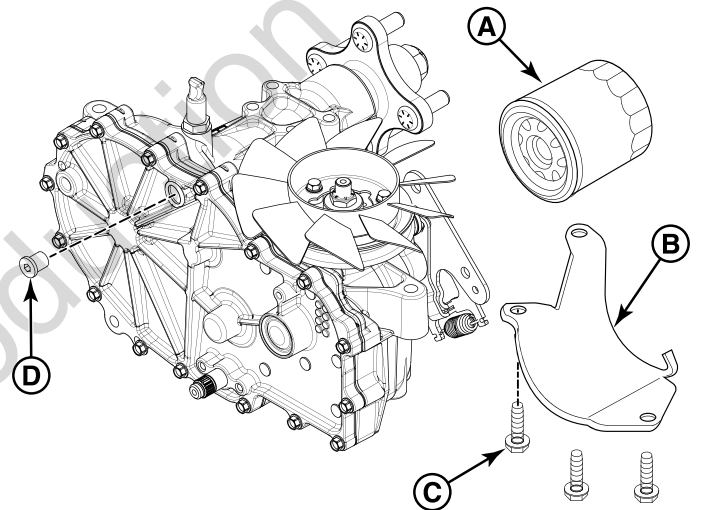

2. Remove the three 1/4" filter guard screws (C) and the filter guard (B).
3. Clean the area around the filter base and remove the filter.
4. Apply a film of new oil to the gasket of the new replacement filter. After the oil has drained, thread the new filter onto the filter base until the gasket makes contact, then tighten 3/4 of a turn more.
5. Reinstall the filter guard with the three 1/4" filter guard screws
6. Using a hex bit swivel socket or a modified allen wrench remove the top port plug (D) from the transmissions.
7. Remove the transmission expansion tank cap and fill with oil until oil appears at the bottom of the transmission's top port (approximately 2 qts (1,89 L).

8. Reinstall the top port plug and tighten to 15 ft lbs (20,38 Nm).
9. Continue to add oil to the transmission oil expansion tank until the oil level reaches the "FULL COLD" mark. Reinstall the transmission expansion tank cap.
10. Repeat this process for the other side of the machine.
11. Perform the *Purging the Air from the Hydraulic System* procedure.

Purging the Air from the Hydraulic System

Due to the effects air has on efficiency in hydraulic drive systems, it is critical that it be purged from the system. These purge procedures should be implemented any time a hydraulic system has been opened to facilitate maintenance or any additional oil has been added to the system.

The resulting symptoms of air in the hydraulic system may be:

- Noisy operation.
- Lack of power or drive after short term operation.
- High operation temperature and excessive expansion of oil.

Before starting, make sure the transaxles/transmissions are at the proper oil levels. If it is not, fill to the specifications outlined in the *Check / Fill Transmission Oil Level* procedure.

Purging Air from the Hydraulic System:

1. Chock the front wheels to prevent the machine from rolling. Raise the rear of the machine so that the vehicle's rear tires do not contact the ground. Position jack stands under the rear bumper of the machine to secure it.
2. Open the transaxle's bypass valves (see *Pushing the Rider by Hand* for the location and function of the bypass valves), start the engine, release the parking brake, and slowly move the zero-turn rider's ground speed control levers in both forward and reverse directions (5 to 6 times), as air is purged from the unit, the oil level will drop.
3. Stop the engine and engage the parking brake.
4. Close the transaxle's bypass valves, start the engine, release the parking brake, and slowly move the zero-turn rider's ground speed control levers in both forward and reverse directions (5 to 6 times), as air is purged from the unit, the oil level will drop.
5. Stop the engine. Remove the jack stands from underneath the machine.
6. Repeat the process detailed above but with the unit's drive wheels on the ground. The procedure should be performed in an area free of any objects or bystanders.

It may be necessary to repeat the process detailed above until all the air is completely purged from the system. When the transaxles/transmissions operate at normal noise levels and move smoothly forward and reverse at normal speeds, then the transaxles/transmissions are considered purged.

Servicing the Mower Blades

Removing the Mower Blades



CAUTION

Laceration hazard

Mower blades are sharp.

Always wear gloves when handling, or working near, mower blades.

1. Use a block of wood to prevent the mower blade from turning as shown in Figure 29.

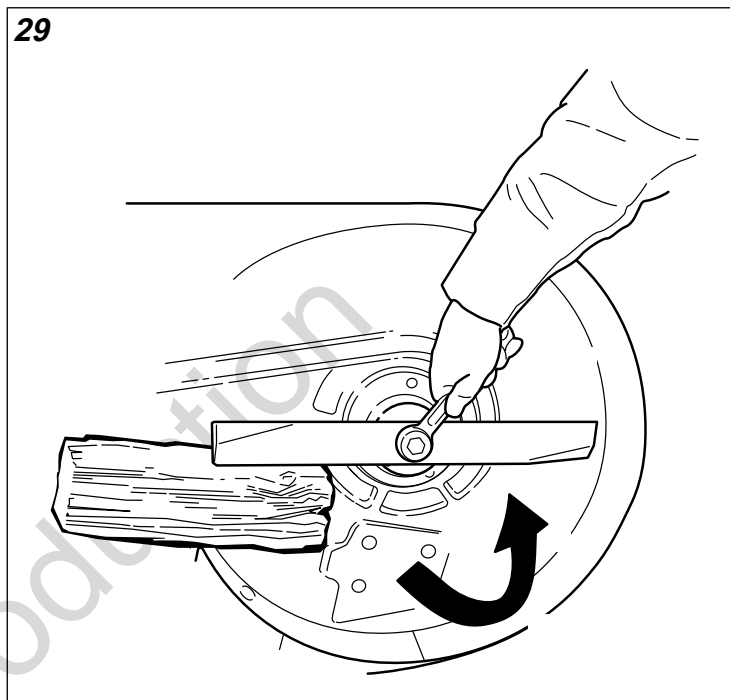

2. Using a wrench, remove the bolt securing the blade to the spindle.

Inspecting the Mower Blades



DANGER



Thrown objects hazard

Avoid injury: a worn or damaged mower blade can break and a piece of the blade could be thrown into the operator's area or bystander's area resulting in serious personal injury or death.

- Inspect the mower blade every 25 hours or at least once per year.
- If the mower blade hits a solid object, stop the engine immediately and inspect the mower blades.
- Never weld or straighten bent mower blades.

1. Remove the mower blade from the unit. See *Removing the Mower Blades*.

2. Inspect the mower blade (Figures 30 and 31). Discard the mower blade if it has any of the following conditions:

- More than .5" (12,7 mm) of the mower blade metal has been removed from previous sharpening or wear (A, Figure 30)
- The air lifts are excessively eroded (A, Figure 31) and the notch (B) is .25" (6,35 mm) deep or greater.
- The mower blade is broken or bent.

30

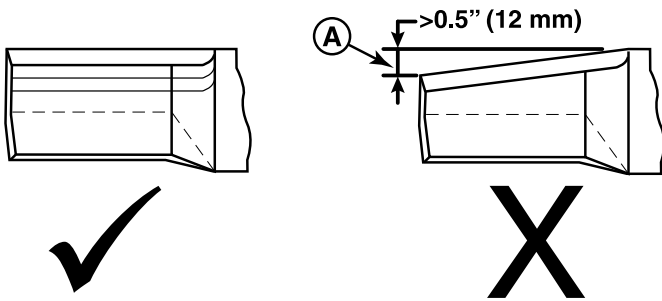

31

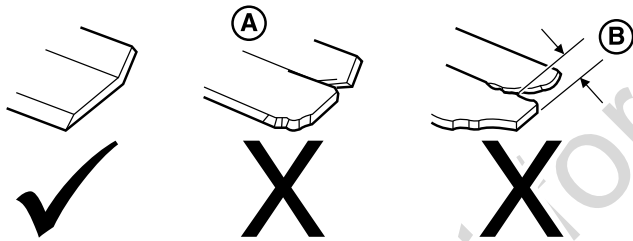

3. If the cutting edges are not sharp or have nicks, sharpen the blades. See Sharpening the Mower Blades.

Sharpening the Mower Blades



Thrown objects and fire hazard

Grinding mower blades throws sparks and fine metal particles that are capable of igniting gasoline and gasoline vapors, and that can injure unprotected eyes.

Be sure all flammable materials are cleared from the area where grinding will occur.

Always wear safety glasses or goggles when grinding mower blades.

1. Sharpen mower blades with a grinder, hand file, or electric blade sharpener.
2. Sharpen the blade by removing an equal amount of material from the cutting edge of each end of the blade.
3. Keep the original bevel (A, Figure 32) when grinding. DO NOT change the mower blade bevel.

32

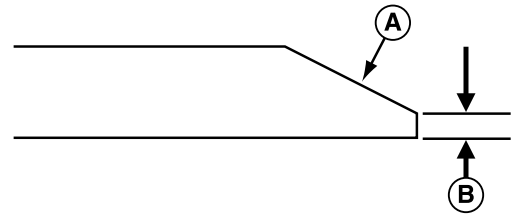

4. The mower blade should have a maximum of 1/64" (0,40 mm) cutting edge (B) or less.

Balancing the Mower Blades



Thrown objects hazard

An unbalanced mower blade can create excessive vibration and damage the unit, or cause mower blade failure resulting in thrown debris.

Be sure blade is balanced before installing.

1. Clean the mower blade to remove any dried grass or other debris.
2. Clamp a nail in a bench vise, hang the mower blade on the nail, and position the blade in a level horizontal position as shown in Figure 33.

33

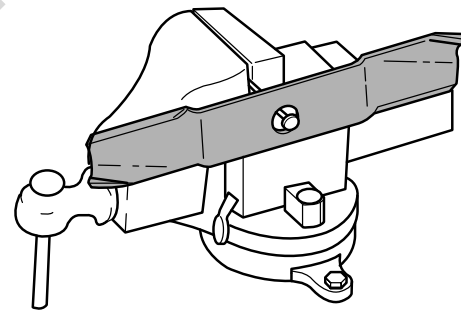

3. Check the balance of the mower blade. If either end of the mower blade moves downward is heavier than the other. Sharpen the heavy end until balance is achieved. See Sharpening the Mower Blades for sharpening instructions.
4. Repeat the process until the mower blade remains in the horizontal, level position.

Installing the Mower Blades

1. Install each mower blade with the air lifts (C, Figure 34) pointing up towards the mower deck as shown in Figure 34 and secure with the mower blade mounting bolt (A) and flat washer (B).

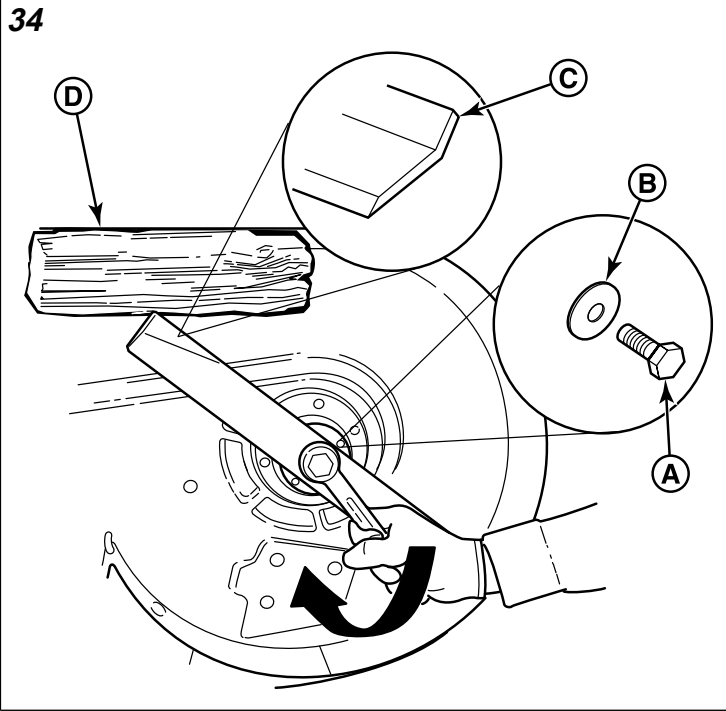

- Wedge a wooden block (D) between the mower blade and the mower deck housing to keep the mower blade from turning and torque the blade mounting bolt to 120 ft. lbs (163 Nm).

Seat Adjustment

The seat can be adjusted forward and back. Move the lever (A, Figure 35) towards the left, position the seat as desired, and release the lever to lock the seat into position.

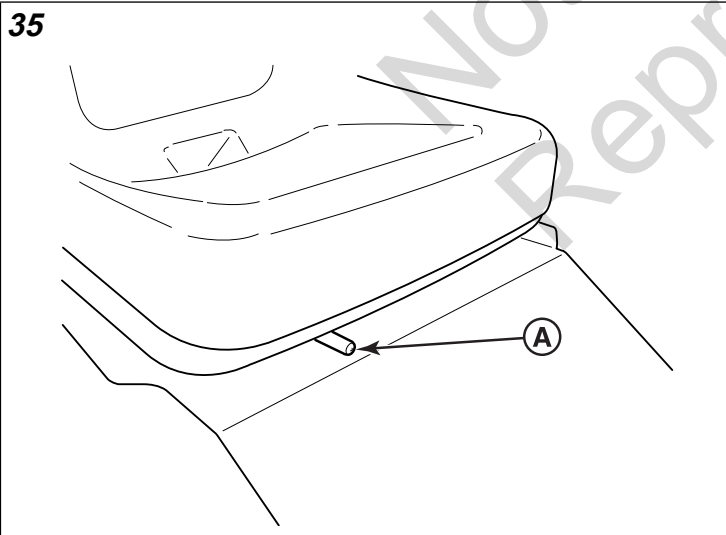

Ground Speed Control Lever Adjustment

The control levers can be adjusted in three ways. The alignment of the control levers, the placement of the levers (how close the ends are to one another) and the height of the levers can be adjusted.

To Adjust the Handle Alignment

Loosen the mount bolts (A, Figure 36) and pivot the lever(s) (C) to align with each other.

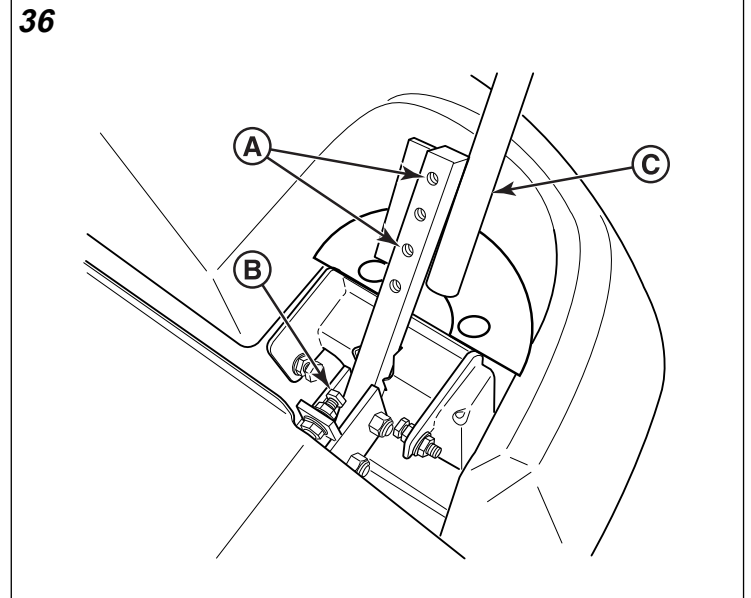

To Adjust the Handle Placement

Loosen the jam nuts and adjust the placement bolt (B) in or out to properly adjust the lever end spacing.

To Adjust the Handle Height

Remove the mounting hardware and reposition the handle either up or down from its original position. You will need to readjust the handle alignment as described above.

Speed Balancing Adjustment

If the rider veers to the right or left when the ground speed control levers are in the maximum forward position, the top speed of each of these levers can be balanced by turning the adjustment bolt(s) (A, Figure 37). Only adjust the speed of the wheel that is traveling faster.

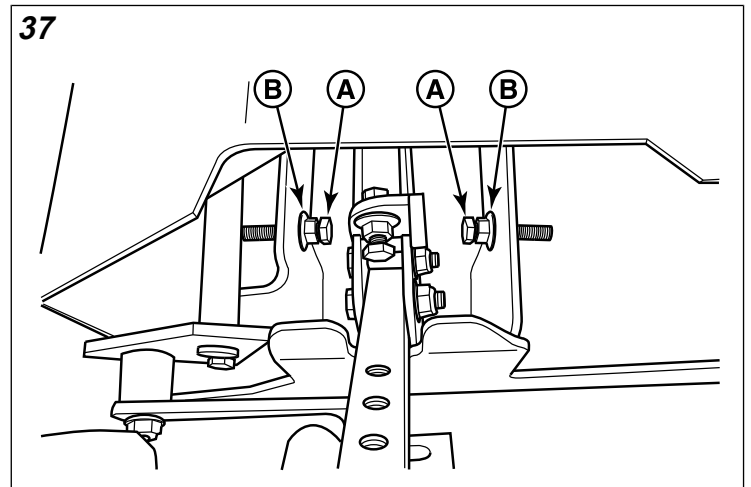

To Reduce the Speed of the Faster Wheel

- Loosen the securing nut (B).

- Turn the top speed adjustment bolt **counter-clockwise** to reduce the speed.
- Retighten the securing nut when adjustment is complete.



WARNING

DO NOT adjust the tractor for a faster overall speed forward or reverse than it was designed for.

Checking Tire Pressures

Tire pressure should be checked periodically, and maintained at the levels shown in the Specifications chart. Note that these pressures may differ slightly from the "Max Inflation" stamped on the side-wall of the tires. The pressures shown provide proper traction and extend tire life.

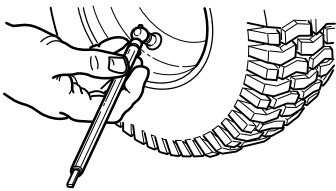

Cutting Height Adjustment

The cutting height adjustment pin (A, Figure 38) controls the mower's cutting height. The cutting height is adjustable between 1-1/2" (3,37 cm) and 4-1/2" (11,47 cm) in 1/4" (0,64 cm) increments.

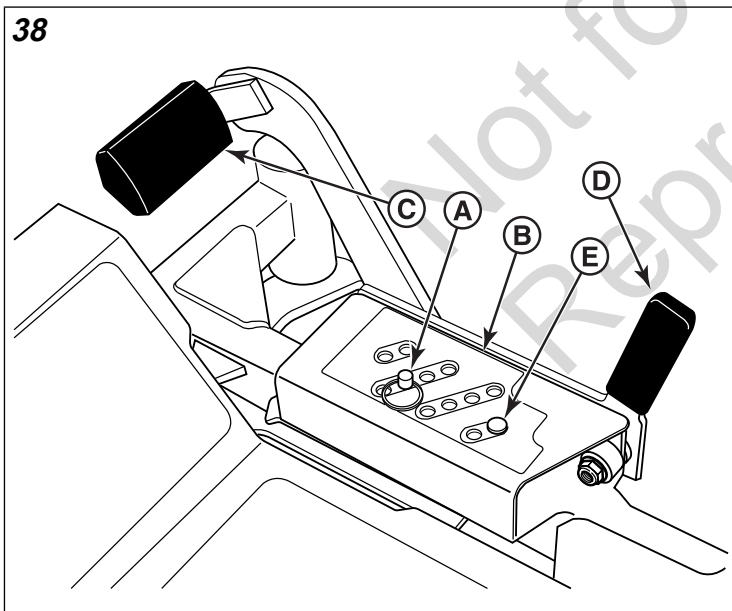

Note: Make sure that the pin is inserted into the holes in both upper and lower plates of the pin box (B).

To set the cutting height at 1-1/2" (3,37 cm):

- While sitting in the operator's seat, press the deck lift foot pedal (C) forward until it locks into the 4-1/2" (11,47 cm) position.
- Remove the cutting height adjustment pin from the hole that it is installed in.

- Press the deck lift foot pedal forward and then pull the lock lever (D) towards the rear of the unit to release the lock.
- Slowly release the deck lift foot pedal until it comes to rest against the stationary pin (E) in the 1-1/2" (3,37 cm) cutting height hole.
- Place the cutting height adjustment pin in any open cutting height hole.

To set the cutting height in the range of 1-3/4" (4,40 cm) and 4-1/4" (10,80 cm):

- While sitting in the operator's seat, press the deck lift foot pedal (C) forward until it locks into the 4-1/2" (11,47 cm) position.
- Place the cutting height adjustment pin in the desired cutting height.
- Press the deck lift pedal forward and then pull the lock lever (D) towards the rear of the unit to release the lock.
- Slowly release the deck lift foot pedal until it comes to rest against the cutting height adjustment pin.

To set the cutting height at 4-1/2" (11,47 cm):

- While sitting in the operator's seat, press the deck lift foot pedal (C) forward until it locks into the 4-1/2" (11,47 cm) position.
- Place the cutting height adjustment pin in any open cutting height hole. The lift lock lever holds the mower deck at 4-1/2" (11,47 cm) while cutting.

Foot Pedal Adjustment

The deck lift foot pedal can be adjusted to accommodate the operator's height for optimal comfort.

To adjust pedal position:

- Remove the foot pedal (A, Figure 39) from the pedal mount tab (B).

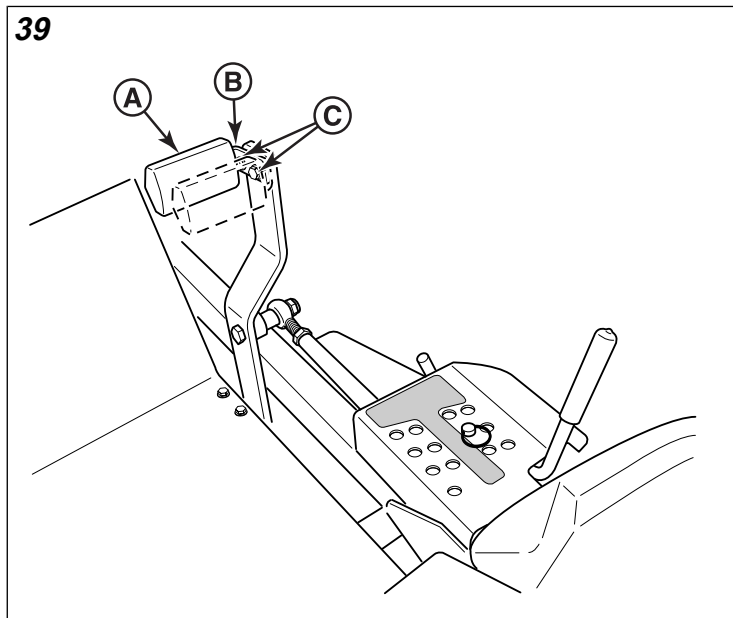

- Remove the pedal mount hardware (C) and rotate the tab 180 degrees.
- Reinstall the pedal mount hardware and tighten securely.
- Reinstall the foot pedal on the pedal mount tab in the proper orientation as shown in Figure 39.

Neutral Adjustment

The neutral system for this mower is a function of the transaxles.

- Drive the machine to a flat, level surface. Engage the parking brake and disengage the PTO.
- Without touching the ground speed control levers disengage the parking brake. If the unit moves, the neutral systems on the transaxles are not correctly adjusted. **See your dealer.**

Return-To-Neutral Adjustment

To determine if it is necessary to adjust the neutral return, perform the following steps:

- Disengage the PTO, engage the parking brake and turn off the engine.
- Move the ground speed control levers into the operating position, pull the levers rearward and release.
- Move the ground speed control levers out towards the NEUTRAL LOCKOUT position. If the levers do not align with the notches in the neutral lock plate, it is necessary to adjust the neutral return rod (B, Figure 40).

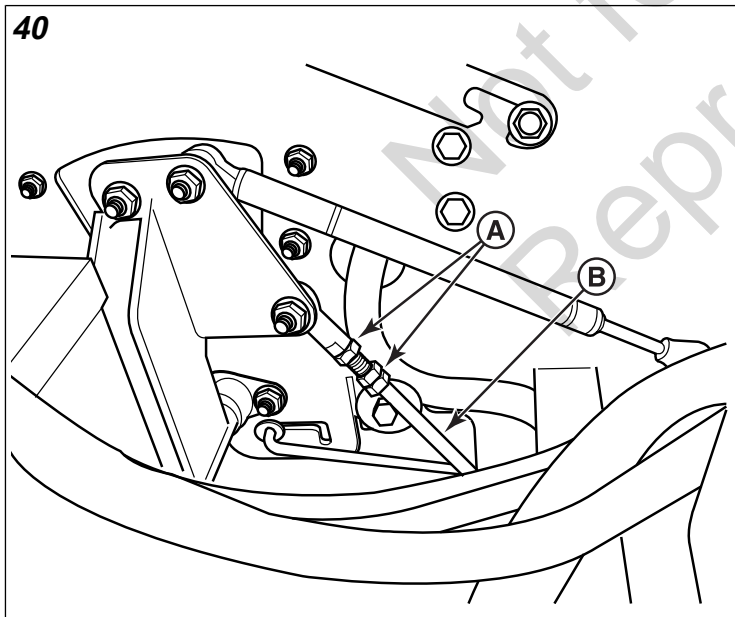

Adjustment



WARNING

To avoid serious injury, perform adjustments only with the engine stopped, the key removed, and the unit on level ground.

- Disengage the PTO, engage the parking brake and turn off the engine.
- There are three jam nuts (A, Figure 40) on the linkage rod (B). The first two are used together to turn the rod and the third (towards the front of the machine) is used to lock the rod in place. Loosen the jam nut that locks against the ball joint and turn the linkage rod to adjust. If the machine creeps forward, turn the linkage rod **clockwise** (while standing at the rear of the machine, facing forward). If the machine creeps backward, turn the rod **counter-clockwise**.
- Lock the jam nut (A) against the ball joint when neutral is achieved.
- Pull the ground speed control lever rearward and release to check position again. Adjust as necessary to align the ground speed control levers with the notches in the neutral lockout plate.

Note: This adjustment should not be performed while the machine is running.

Neutral Lockout Adjustment

Prior to adjusting the neutral lockout, the neutral and return-to-neutral must be properly adjusted.

- Park the unit on a flat, level surface such as a concrete floor. Disengage the PTO, engage the parking brake, turn the ignition switch to OFF, and remove the ignition key.
- Chock the wheels of the unit to prevent movement.
- Raise the seat to gain access to the neutral lockout components.
- Loosen the jam nuts (A, Figure 41) on the neutral lockout bolts (B).

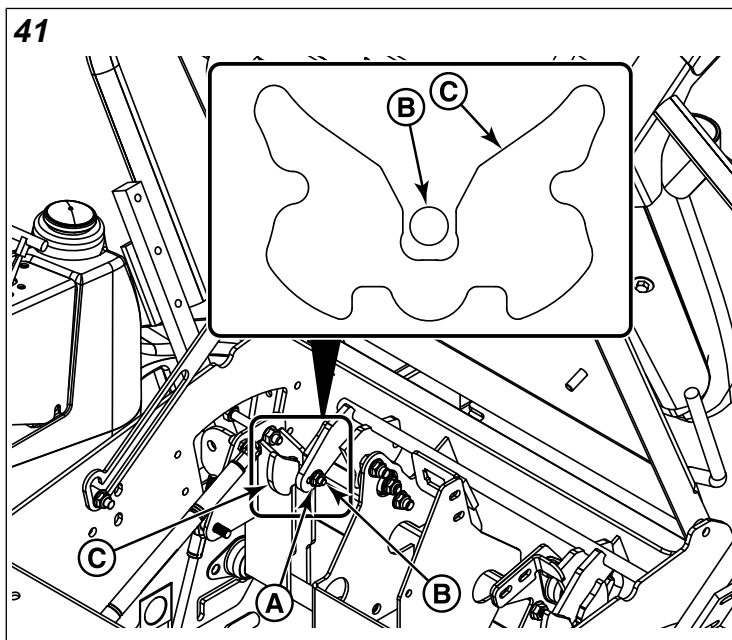

- Engage the parking brake. The neutral lockout bolts will enter the notches of the neutral lockout plates (C).

- Position the neutral lockout bolts to the center of the notches of the neutral lockout plates.
- Re-tighten the jam nuts.

Parking Brake Adjustment

- Park the unit on a flat, level surface such as a concrete floor. Disengage the PTO, engage the parking brake, turn the ignition switch to OFF, and remove the ignition key.
- Raise the seat to gain access to the parking brake components.
- Measure the body length (A, Figure 42) of the parking brake spring (B). The measurement should equal $1\text{-}1/2" \pm 1/8"$ ($3,8\text{ cm} \pm 0,32\text{ cm}$). If not, turn the adjustment nut (C) until the measurement is achieved.

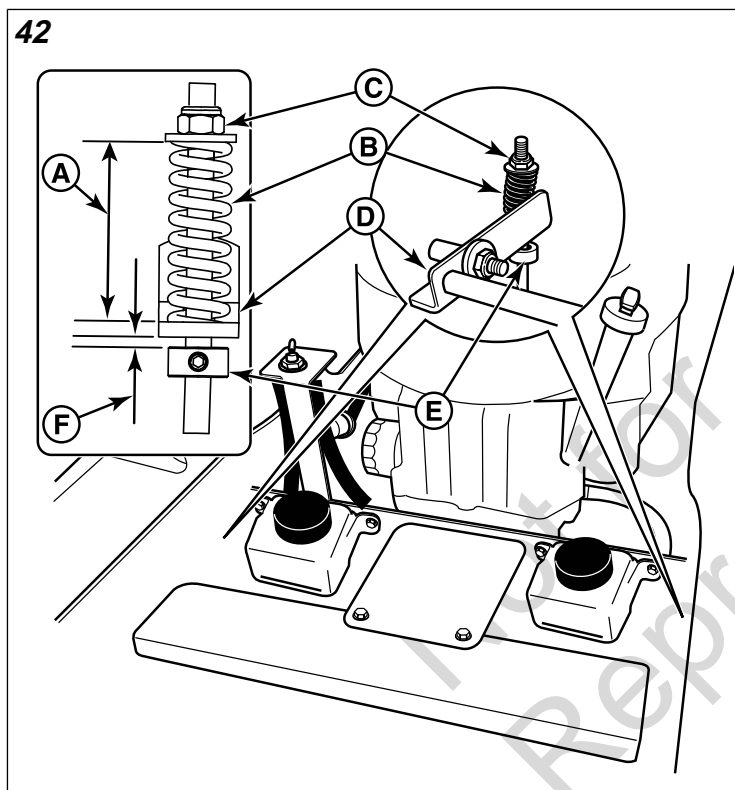

- Measure the distance between the bottom of the brake shaft weldment (D) and the top of the set collar (E). The measurement should be $3/8"$ ($0,38\text{ cm}$) (F). If not, re-position the set collar until the measurement is achieved.
- Repeat this process for the other side of the unit.

If this does not correct the braking problem, see your dealer.

Deck Lift Rod Timing Adjustment

- Park the machine on a flat, level surface. Disengage the PTO, engage the parking brake, turn off the engine, and remove the ignition key. Verify that the tires are properly inflated.

- To check the lift rod timing, measure and record the distance between the lift pivots (A, Figure 43) and the rod pivots (B). Repeat for other side of unit.

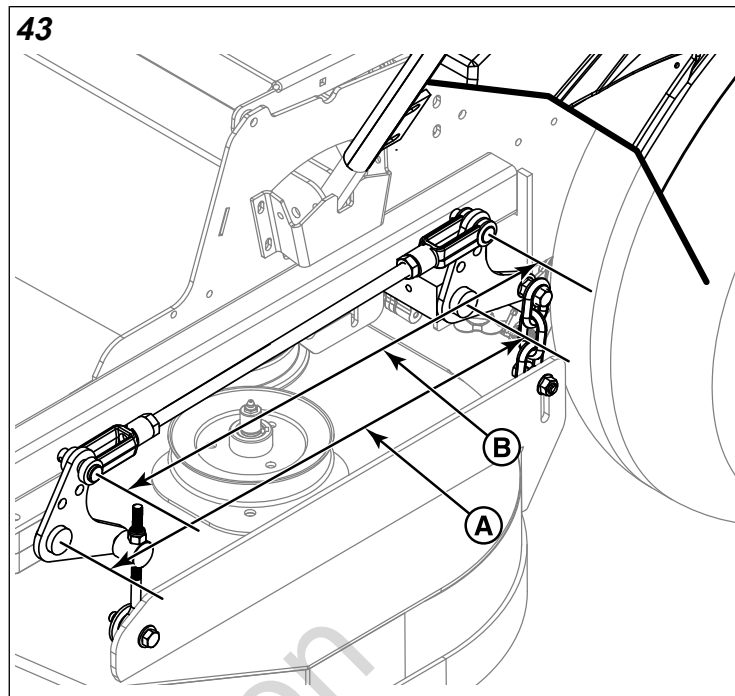

- If the measurements for the rods are equal, no further adjustment is required. If the measurements are NOT equal (greater than $1/8"$ ($3,17\text{ mm}$) difference), adjustment is required continue with Step 4.
- Lock the deck lift pedal in the TRANSPORT position. Remove the cutting height adjustment pin and lower the mower deck.
- To ensure that the deck is in the lowest position, push the pedal by hand towards the rear of the unit and install the height adjustment pin in the $3"$ ($7,6\text{ cm}$) position to hold in place.
- Block up the mower deck until all hanger chains are slack. Refer to Figure 44.

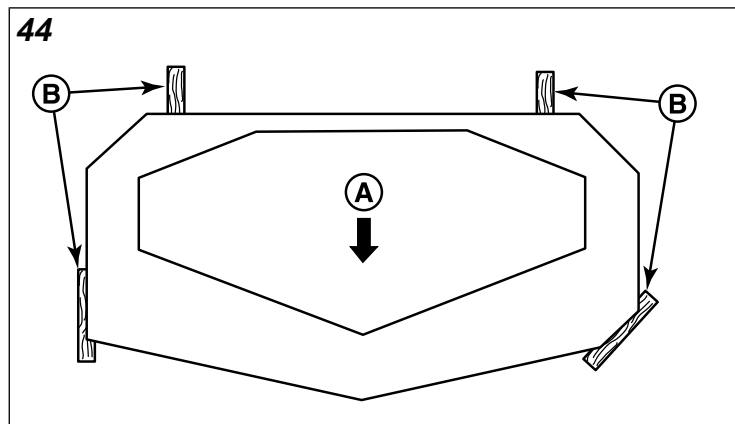

- To adjust the lift rod, loosen the jam nut (A, Figure 45) on the front clevis (B) then remove the $1/2"$ clevis pin (C) fastening the clevis to the lift pivot arm. Reinstall the clevis

on the lift pivot arm and secure with the 1/2" clevis pin previously removed. Tighten the jam nut against the clevis.

- Turn the clevis **clockwise** to shorten the distance between the rod pivots
- Turn the clevis **counter-clockwise** to lengthen the distance between the rod pivots

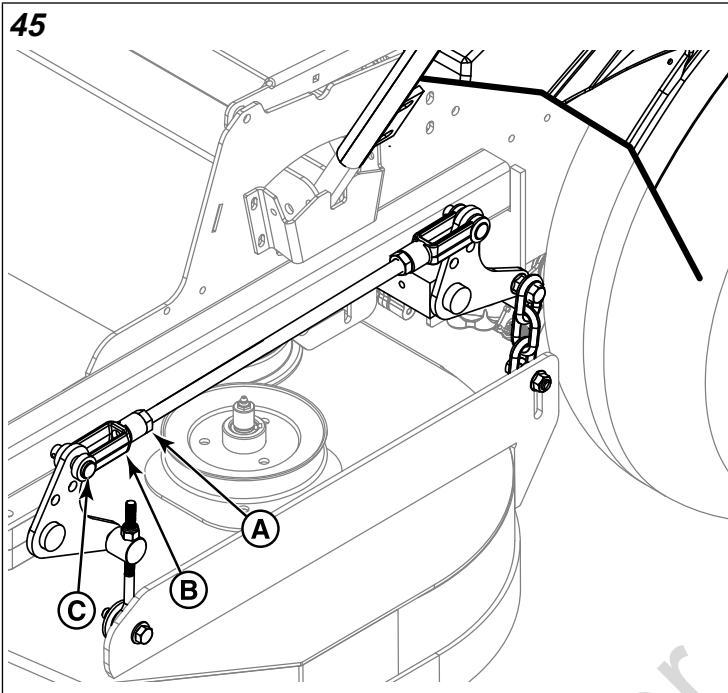

8. Reinstall the clevis on the lift pivot arm and secure with the 1/2" clevis pin previously removed. Tighten the jam nut against the clevis.
9. Remove the blocks from the under the mower deck.
10. Remove the cutting height adjustment pin from in front of the deck lift pedal arm. Lift mower deck and reinstall adjustment pin in desired mowing height.

Deck Leveling Adjustment

Before adjusting the deck level, the deck lift rod timing must be checked and/or adjusted.

Determining if the Deck Leveling Needs to be Adjusted

1. Park the unit on a flat, level surface. Disengage the PTO, engage the parking brake, turn the ignition switch to OFF, and remove the ignition key.
2. Lock the deck lift pedal in the TRANSPORT position. Place the cutting height adjustment pin in the 4" position and lower the deck lift pedal until the deck lift arm contacts the cutting height adjustment pin.
3. Verify that the tires are inflated to the correct pressure.
4. Verify that the mower blades are flat, and not bent or broken. A bent or broken blade must be replaced.

WARNING

Avoid Injury! Mower blades are sharp.

Always wear gloves when handling blades or working near blades.

5. See Figure 46. Position the outside mower blades so they face front-to-back.

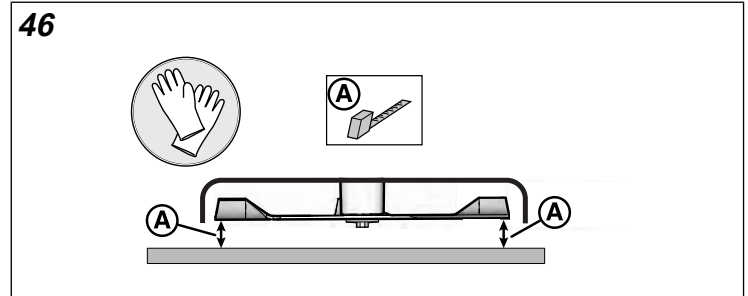

6. Measure the front tip (A, Figure 46) of the blade from the cutting edge to the ground.
7. Measure the rear tip (A) of the blade from the cutting edge to the ground.
8. Repeat the process on the other side of the machine.
 - the front measurements should equal 4" (10,2 cm).
 - the rear measurements should equal 4-1/4" (10,8 cm)

If the measurements do not equal the measurements as listed above, adjust the deck leveling.

Deck Leveling Adjustment

1. Lock the deck lift pedal in the TRANSPORT position. Place the deck height adjustment pin in the 4" (10,2 cm) position and lower the deck lift pedal until the arm contacts the pin.
2. Place 2 X 4 block under each corner of the mower deck with the 3-1/2" sides being vertical. Place a 1/4" (0,64 cm) thick spacer on top of the rear 2 X 4 blocks.
3. Turn the nut (A, Figure 47) on the eye bolt (B) until the front of the deck is resting on the 2 X 4's.

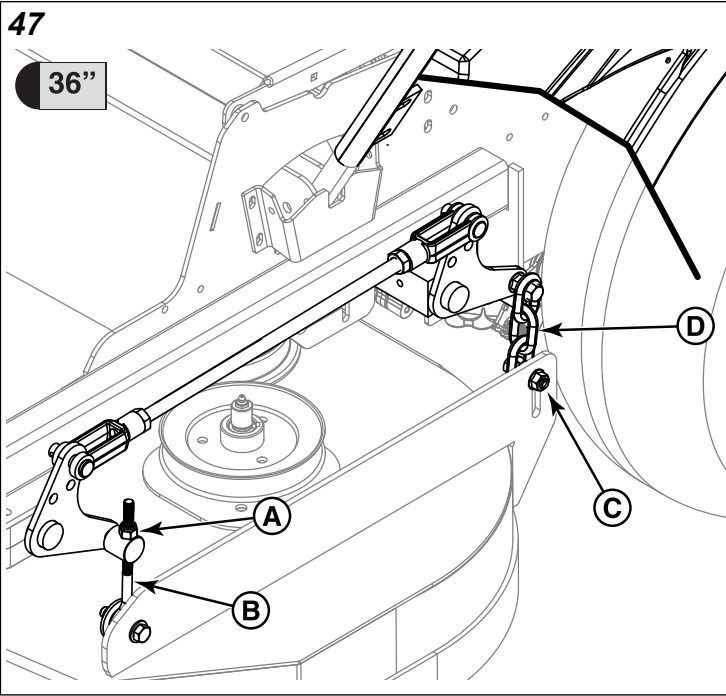

4. Loosen the nuts (C) and allow the rear of the deck to rest on the 2 X 4's and 1/4" spacers. Slide the chains (D) down in the slots until the chains are tight and tighten the nuts.
5. Repeat the process for the other side of the unit.
6. Remove all 2 X 4 blocks and spacers from under the mower deck.

Mower Deck Drive Belt Replacement

NOTICE To avoid damaging belts, do not pry over pulleys.

1. Park the unit on a smooth level surface such as a concrete floor. Disengage the PTO, engage the parking brake, turn off the engine and remove the ignition key.
2. Lower the mower deck to it's lowest cutting position and remove the mower deck guards and the floor pan.

WARNING

Use extreme caution when rotating the idler arm with the breaker bar, due to the increased tension in the spring as the idler arm is being rotated. Injury may result if the breaker bar is prematurely released while the spring is under tension.

3. Using a 1/2" breaker bar, place the square end in the opening located in the end of the idler arm (A, Figure 48). Carefully rotate the breaker bar **counter-clockwise** which will relieve the tension on the belt exerted from the idler arm.

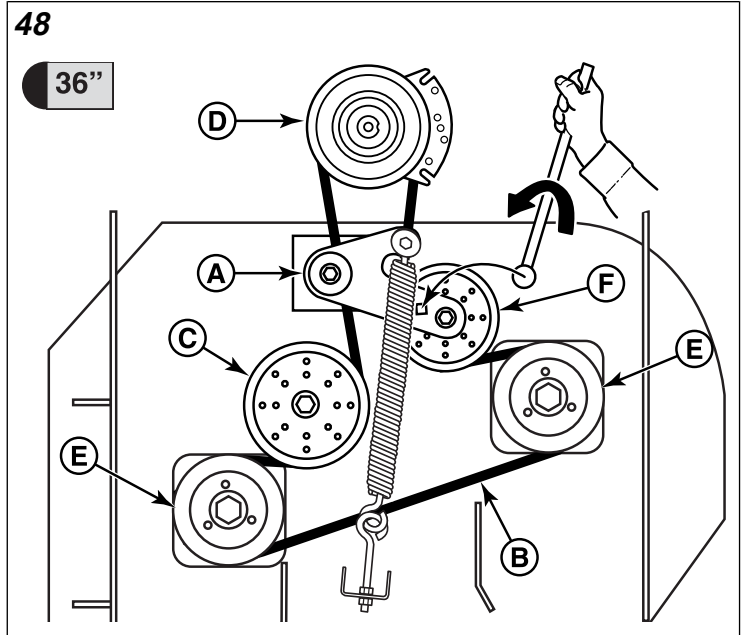

4. Slide the drive belt (B) over the edge of the stationary idler pulley (C). Carefully release the tension on the breaker bar.
5. Remove the old belt and replace with a new one. Make sure that the V-side of the belt runs in the pulley grooves.
6. Install the drive belt on the PTO pulley (D), the spindle pulleys (E). Make sure that the back side of the belt contacts of the face of the adjustable idler pulley (F).
7. Carefully rotate the breaker bar **counter-clockwise** and install the belt on the rear stationary idler pulley. Carefully release the tension on the breaker bar.

Check / Adjust Deck Drive Belt Tensioning Spring Length

Deck Drive Belt Tensioning Spring Length	
Deck Size	Measurement
36"	11-3/4" ± 1/8" (29,8 cm ± 0,32 cm)

1. Set the mower deck to the 3-1/2" (8.9 cm) cutting height.
2. Use the *Deck Drive Belt Tensioning Spring Length* chart to determine the correct spring length for your unit.
3. Measure the coil length (A, Figure 49) of the deck drive belt tensioning spring (B). The measurement should equal the measurement as indicated in the chart. If not, continue with step #4.

49

36"

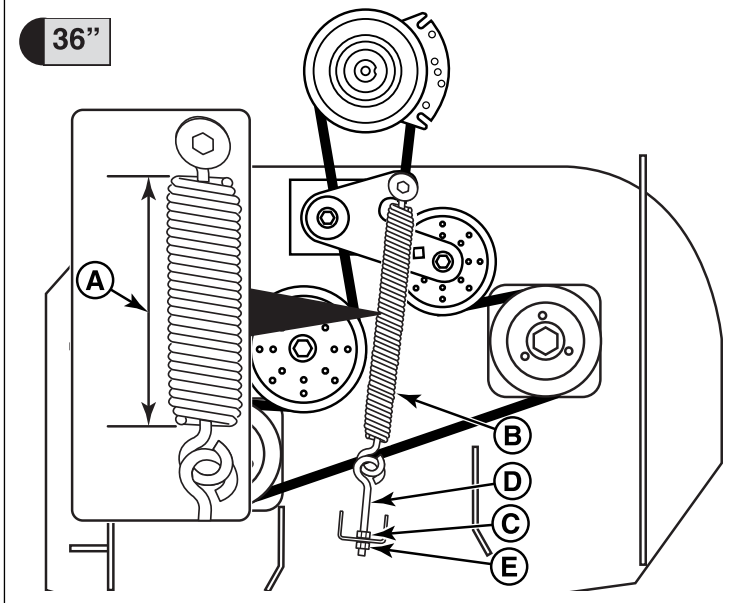

4. Loosen the jam nut (C) on the eye bolt (D).
5. Turn the adjustment nut (E) until the measurement as indicated in the chart is achieved.
6. Re-tighten the jam nut.
7. Re-install the mower deck guards and floor pan.
8. Run the mower under no-load condition for about five (5) minutes to break in the new belt.

Transaxle Drive Belt Replacement

1. Park the unit on a smooth, level surface such as a concrete floor. Disengage the PTO, engage the parking brake, turn off the engine, and remove the ignition key.
2. Remove the mower deck drive belt (see *Mower Deck Drive Belt Replacement* for removal instructions).
3. Disconnect the wire harness from the PTO clutch.
4. Loosen and remove the left rear engine mounting bolt (A, Figure 50) that secures the clutch anchor bracket (B) to the engine deck. Remove the PTO clutch anchor bracket from the engine deck and the PTO clutch (C).

50

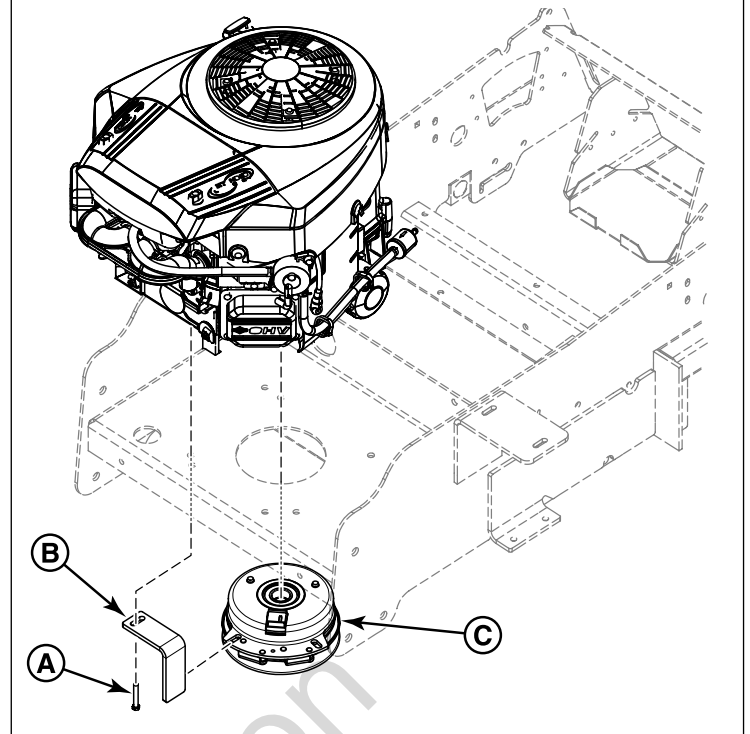

Note: Use extreme caution when rotating the idler arm with the breaker bar, due to the increased tension on the spring as the idler arm is being rotated. Injury may result if the breaker bar is being prematurely released while the spring is under tension.

5. Using a 1/2" breaker bar place the square end in the opening located in the end of the idler arm (A, Figure 51). Carefully rotate the breaker bar **counter-clockwise**, which will relieve the tension on the belt exerted from the idler arm.

51

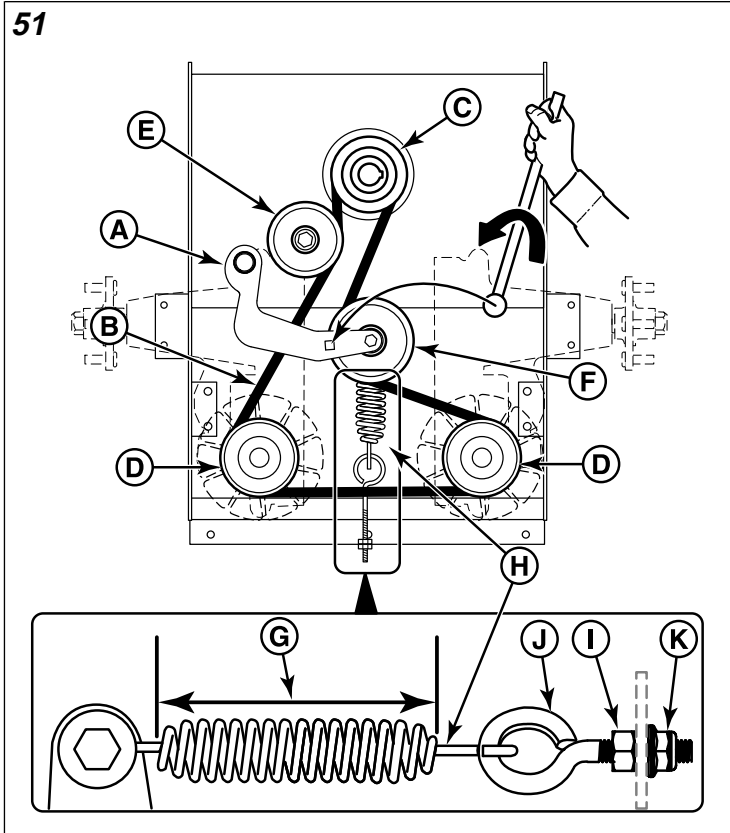

6. Remove the transaxle drive belt (B) from the crankshaft pulley (C).
7. Remove the old belt and replace it with the new one. Make sure the V-side of the belt runs in the grooves of the transmission pulleys (D). Make sure that the flat side of the belt contacts the face of the rear stationary idler pulley (E) and the adjustable idler pulley (F).
8. Carefully rotate the breaker bar **counter-clockwise** and install the belt on the crankshaft pulley. Carefully release the tension on the breaker bar.
9. Measure the coil-to-coil length (G) of the belt tensioning spring (H). The measurement should equal $6\text{-}1/4" \pm 1/8"$ ($16,5\text{ cm} \pm 0,32\text{ cm}$). If not, continue with step #10
10. Loosen the jam nut (I) on the eye bolt (J).
11. Turn the adjustment nut (K) until the coil-to-coil measurement equals $6\text{-}1/4" \pm 1/8"$ ($16,5\text{ cm} \pm 0,32\text{ cm}$).
12. Re-tighten the jam nut.
13. Re-install the PTO clutch mounting tab into the slot in the PTO clutch and then secure the PTO clutch mounting tab to the engine deck using the left rear engine mounting bolt previously removed.
14. Re-connect the wire harness to the PTO clutch and use a new self-locking tie to secure the harness away from the belt and the pulleys.
15. Reinstall the mower deck drive belt (see *Mower Deck Drive Belt Replacement* for installation instructions).

Cleaning the Battery and Cables

Note: This unit is equipped with a maintenance-free BCIU1 battery.



WARNING

Be careful when handling the battery. Avoid spilling electrolyte. Keep flames and sparks away from the battery. When removing or installing battery cables, disconnect the negative cable **FIRST** and reconnect it **LAST**. If not done in this order, the positive terminal can be shorted to the frame by a tool.

1. Disconnect the cables from the battery, negative (black) cable first (B, Figure 52).

52

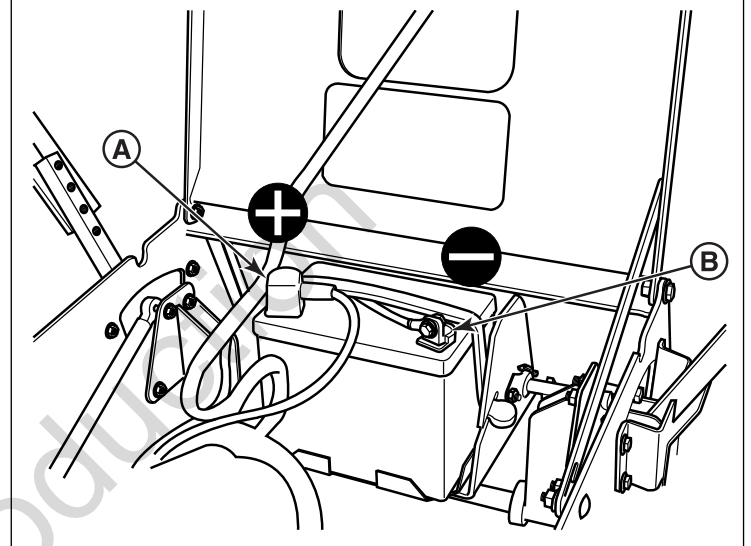

2. Clean the battery terminals and cable ends with a wire brush until shiny.
3. Reinstall the battery and reattach the battery cables, positive (red) cable first (A).
4. Coat the cable ends and battery terminals with petroleum jelly or non-conducting grease.

Battery Service



WARNING

Keep open flames and sparks away from the battery; the gasses coming from it are highly explosive. Ventilate the battery well during charging.

Checking Battery Voltage

A voltmeter can be used to determine condition of battery. When engine is off, the voltmeter shows battery voltage, which should be 12 volts. When engine is running, the voltmeter shows voltage of charging circuit which normally is 13 to 14 volts.

A dead battery or one too weak to start the engine may not mean the battery needs to be replaced. For example, it may mean that the alternator is not charging the battery properly. If

there is any doubt about the cause of the problem, see your dealer. If you need to replace the battery, follow the steps under Cleaning the Battery & Cables in the Regular Maintenance Section.

Charging a Completely Discharged Battery



WARNING

- Do NOT charge battery with key switch ON.
 - Never use a quick battery charger to start engine.
 - Always disconnect negative (-) battery cable before charging battery,
1. Be aware of all the safety precautions you should observe during the charging operation. If you are unfamiliar with the use of a battery charger and hydrometer, have the battery serviced by your dealer.
 2. Add distilled water sufficient to cover the plate (fill to the proper level near the end of the charge). If the battery is extremely cold, allow it to warm before adding water because the water level will rise as it warms. Also, an extremely cold battery will not accept a normal charge until it becomes warm.
 3. Always unplug or turn the charger off before attaching or removing the clamp connections.
 4. Carefully attach the clamps to the battery in proper polarity (usually red to [+] positive and black to [-] negative).
 5. While charging, periodically measure the temperature of the electrolyte. If the temperature exceeds 125° F (51.6° C), or if violent gassing or spewing of electrolyte occurs, the charging rate must be reduced or temporarily halted to prevent battery damage.
 6. Charge the battery until fully charged (until the specific gravity of the electrolyte is 1.250 or higher and the electrolyte temperature is at least 60° F). The best method of making certain a battery is fully charged, but not over charged, is to measure the specific gravity of a cell once per hour. The battery is fully charged when the cells are gassing freely at low charging rate and less than 0.003 change in specific gravity occurs over a three hour period.

Jump Starting With Auxiliary (Booster) Battery

Jump starting is not recommended. However, if it must be done, follow these directions. Both booster and dis-charged batteries should be treated carefully when using jumper cables. Follow the steps below EXACTLY, being careful not to cause sparks. Refer to Figure 53.



WARNING

For your personal safety, use extreme care when jump starting. Never expose battery to open flame or electric spark – battery action generates hydrogen gas which is flammable and explosive. Do not allow battery acid to contact skin, eyes, fabrics, or painted surfaces. Batteries contain a sulfuric acid solution which can cause serious personal injury or property damage.

To avoid engine damage, do not disconnect battery while engine is running. Be sure terminal connections are tight before starting.

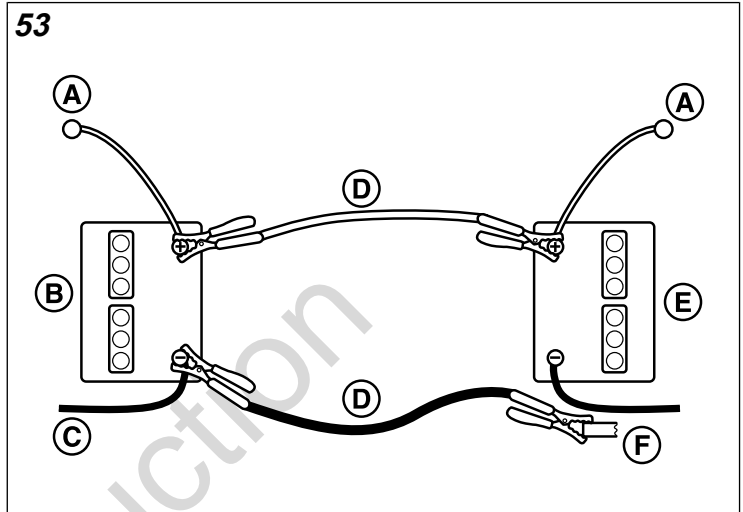

This hook-up is for negative grounded vehicles.

Callout	Description
A	To Starter Switch
B	Starting Vehicle Battery
C	To Ground
D	Jumper Cable
E	Discharged Vehicle Battery
F	Engine Block

Make sure vehicles do not touch.

1. Both batteries must be of the same voltage.
2. Position the vehicle with the booster battery adjacent to the vehicle with the discharged battery so that booster cables can be connected easily to the batteries in both vehicles. Make certain vehicles do not touch each other.
3. Wear safety glasses and shield eyes and face from batteries at all times. Be sure vent caps are tight. Place damp cloth over vent caps on both batteries.
4. Connect positive (+) cable to positive post of discharged battery (wired to starter or solenoid).
5. Connect the other end of same cable to same post marked positive (+) on booster battery.
6. Connect the second cable negative (-) to other post of booster battery.

7. Make final connection on engine block of stalled vehicle away from battery. Do not lean over batteries.
8. Start the engine of the vehicle with the booster battery. Wait a few minutes, then attempt to start the engine of the vehicle with the discharged battery.
9. If the vehicle does not start after cranking for ten (10) seconds, STOP PROCEDURE. More than ten (10) seconds seldom starts the engine unless some mechanical adjustment is made. Allow a sixty (60) second cool down period between starting attempts. Failure to follow these guidelines can burn out starter motor.
10. After starting, allow the engine to return to idle speed. Remove the cable connection at the engine or frame. Then remove the other end of the same cable from the booster battery.
11. Remove the other cable by disconnecting at the discharged battery first and then disconnect the opposite end from the booster battery.
12. Discard the damp cloths that were placed over the battery vent caps.



Any procedure other than the preceding could result in:

- (a) personal injury caused by electrolyte squirting out the battery vents,
- (b) personal injury or property damage due to battery explosion,
- (c) damage to the charging system of the booster vehicle or of the immobilized vehicle.

Do not attempt to jump start a vehicle having a frozen battery because the battery may rupture or explode. If a frozen battery is suspected, examine all fill vents on the battery. If ice can be seen or if the electrolyte fluid cannot be seen, do not attempt to start with jumper cables as long as the battery remains frozen.

Troubleshooting

While normal care and regular maintenance will extend the life of your equipment, prolonged or constant use may eventually require that service be performed to allow it to continue to operating properly.

This troubleshooting guide lists the most common problems, their causes and remedies.

Refer to **Maintenance Procedures** for instructions on how to perform most of these minor adjustments and service repairs yourself. If you prefer, all of these procedures can be performed for you by your local authorized dealer.



Remove ignition key prior to performing maintenance on the unit.

To avoid serious injury, perform maintenance on the unit or mower deck only when the engine is stopped and the parking brake is engaged.

Always remove the ignition key, disconnect the spark plug wire(s) and fasten it away from the plug(s) before beginning the maintenance, to prevent accidental starting of the engine.

Troubleshooting Charts

Troubleshooting the Rider

Problem: Engine will not turn over or start.	
Cause	Remedy
Parking brake not engaged.	Engage parking brake.
PTO (electric clutch) switch in ON position.	Place in OFF position.
Ground speed control levers not in "NEUTRAL" position.	Move ground speed control levers to the "NEUTRAL" position.
Out of fuel.	If engine is hot, allow it to cool, then refill the fuel tank.
Engine flooded.	Move choke control to the closed position.
Fuse blown.	Replace fuse.
Battery terminals require cleaning.	Clean the battery terminals.
Battery discharged or dead.	Recharge or replace.
Wiring loose or broken.	Visually check wiring and replace broken or frayed wires. Tighten loose connections.
Solenoid or starter motor faulty.	Repair or replace. See authorized dealer.
Safety interlock switch faulty.	Replace as needed. See authorized dealer.
Spark plug(s) faulty, fouled, or incorrectly gapped.	Clean and gap, or replace. See engine operator's manual.
Water in fuel.	Drain fuel and replace with fresh fuel.
Gas is old or stale.	Drain fuel and replace with fresh fuel.

Problem: Engine starts hard or runs poorly.	
Cause	Remedy
Fuel mixture too rich.	Clean air filter. Check choke adjustment.
Spark plug(s) faulty, fouled, or incorrectly gapped.	Clean and gap, or replace. See engine operator's manual.

Problem: Engine knocks.	
Cause	Remedy
Low oil level.	Check and add oil as required.
Using wrong grade oil.	See engine operator's manual.

Problem: Excessive oil consumption.	
Cause	Remedy
Engine running too hot.	Clean engine fins, blower screen, and air cleaner.

Problem: Excessive oil consumption.	
Using wrong weight oil.	See engine operator's manual.
Too much oil in crankcase.	Drain excess oil.

Engine exhaust is black.	
Cause	Remedy
Dirty air filter.	Replace air filter. See engine operator's manual.
Engine choke is in closed position.	Open choke control.

Problem: Engine runs, but rider will not drive.	
Cause	Remedy
Transmission release lever(s) in "free-wheel" position	Move transmission release lever(s) to the "drive" position.
Belt is broken.	Replace belt. See Transmission Drive Belt Replacement.
Drive belt slips.	See problem and cause below.
Brake is not fully released.	See authorized dealer.

Problem: Rider drive belt slips.	
Cause	Remedy
Pulleys or belt is greasy or oily.	Clean as required.
Tension too loose.	Adjust the spring tension. See Transmission Drive Belt Replacement.
Belt stretched or worn.	Replace belt.

Problem: Brake will not hold.	
Cause	Remedy
Brake is incorrectly adjusted.	See Parking Brake Adjustment.
Braking components in transmission worn.	See authorized dealer.

Problem: Rider steers or handles poorly.	
Cause	Remedy
Steering lever linkages are loose.	Check and tighten any loose connections.
Improper tire inflation.	See Checking Tire Pressures

Troubleshooting the Mower Deck

Problem: Mower will not raise.	
Cause	Remedy
Lift linkage not properly attached or damaged.	See authorized dealer.

Problem: Engine stalls easily with mower engaged.	
Cause	Remedy
Engine speed too slow.	Set to full throttle.
Ground speed too fast.	Decrease ground speed.
Cutting height set too low.	Cut tall grass at maximum cutting height during first pass.
Discharge chute jamming with cut grass.	Cut grass with discharge pointing towards previously cut area.

Problem: Excessive mower vibration.	
Cause	Remedy
Blade mounting bolts are loose.	Tighten to 120 ft-lbs (163 Nm).

Problem: Excessive mower vibration.	
Mower blades, arbors, or pulleys are bent.	Check and replace as necessary.
Mower blades are not balanced.	Remove, sharpen, and balance blades. See Servicing the Mower Blades.
Belt installed incorrectly.	Reinstall the belt correctly.

Problem: Excessive belt wear or breakage.	
Cause	Remedy
Bent or rough pulleys.	Repair or replace.
Using incorrect belt.	Replace with correct belt.

Problem: Mower drive belt slips, or fails to drive.	
Cause	Remedy
Idler pulley spring broken, or not properly attached.	Repair or replace as needed.
Mower drive belt broken.	Replace mower drive belt.

Problem: Mower does not engage.	
Cause	Remedy
Electrical wiring damage.	Locate and repair damaged wire.
Battery voltage too low.	Recharge battery and check alternator. See Battery Maintenance.

Troubleshooting Common Cutting Problems

Problem: Striking	
Striking is when thin strips of uncut grass are left behind the mower. Striking is usually caused by operator error or poor blade maintenance.	

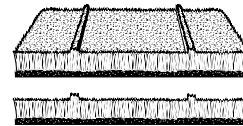

Cause	Remedy
Blades are not sharp.	Sharpen your blades.
Blades are worn down too far.	Replace your blades.
Engine speed is too slow.	Always mow at full throttle.
Ground speed is too fast.	Slow down.
Deck is plugged with grass.	Clean out the mower.
Not overlapping cutting rows enough.	Overlap your cutting rows
Not overlapping enough when turning.	When turning your effective cutting width decreases—overlap more when turning.

Problem: Scalping	
Scalping is when the mower deck comes close to or hits the ground. Scalping can be caused by the mower deck misadjustment, unevenness in the lawn, or by mower deck bouncing because the ground speed is too fast.	

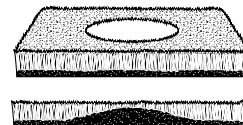

Cause	Remedy
Lawn is uneven or bumpy.	Roll or level the lawn.

Problem: Scalping	
Mower deck cutting height is set too low.	Raise the cutting height.
Ground speed is too fast.	Slow down.
Deck is not leveled correctly.	Correctly level the deck.
Tire pressure is low or uneven.	Check and inflate the tires.

Problem: Stepped Cutting

Stepped cutting is sharp ridges or uneven levels left in the lawn surface. Stepped cutting is usually caused by mower deck damage or misadjustment, or damage to the mower blades.

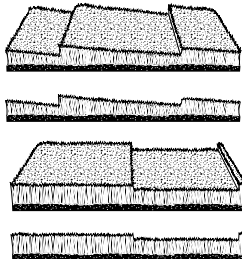

Cause	Remedy
Deck is not leveled correctly.	Level the deck correctly.
Tires are not properly inflated.	Check and inflate the tires.
Blades are damaged.	Replace the blades.
Deck shell is damaged.	Repair or replace the deck.
Mower spindle is bent or loose.	Repair or replace the spindle.
Blades are installed incorrectly.	Reinstall the blades correctly.

Problem: Uneven Cutting

Uneven cutting is waviness or smooth troughs in the lawn surface. Uneven cutting is usually caused by mower deck damage or misadjustment.

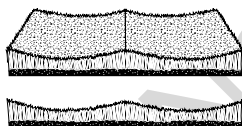

Cause	Remedy
Deck is not leveled correctly.	Level the deck correctly.
Blades are dull or worn.	Sharpen or replace the blades.
Blades are damaged.	Replace the blades.
Deck is clogged with grass clippings.	Clean out the deck.
Deck shell is damaged.	Repair or replace the deck.
Mower spindle is bent or loose.	Repair or replace the spindle.
Blades are installed incorrectly.	Reinstall the blades correctly.
Tires are not properly inflated.	Check and inflate the tires.

Problem: Stringers

Stringers are sparse patches of uncut grass left behind the mower. Stringers are usually caused by operator error or poor blade maintenance.

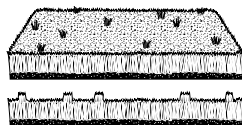

Cause	Remedy
Blades are not sharp or nicked.	Sharpen your blades.
Blades are worn down too far.	Replace your blades.

Problem: Stringers	
Engine speed is too slow.	Always mow at full throttle.
Ground speed is too fast.	Slow down.
Deck is plugged with grass.	Clean out the mower.

Specifications

Specifications are correct at time of printing and are subject to change without notice.

ENGINE

For complete engine specifications see the engine manufacturer's operator's manual included with your unit.

Fits models: 5901549 & 5901688

Kawasaki FX600V	
Make	Kawasaki
Model	FX600V
Electrical System	12 volt, 15 amp charging coil; Battery: 340 cca

Fits models: 5901548 & 5901689

Briggs & Stratton Commercial Turf 44T977	
Make	Briggs & Stratton
Model	44T977-0005-G1
Electrical System	12 volt, 16 amp. alternator; Battery: 340 cca

CHASSIS

Fuel Tank Capacity	8 gallons (41,6 L) total
Rear Wheels	
Tire Size	20 X 7.00 - 10
Inflation Pressure	15 psi (1,03 bar)
Front Wheels	
Tire Size	11 X 4.00 - 5
Inflation Pressure	N/A (flat free tire)

TRANSMISSIONS

Make	Hydro-Gear®
Model	ZL-KMEF-3L7C-1PLX (LH) ZL-GMEF-3L7B-1PLX (RH)
Type	ZT3100 Transaxles
Hydraulic Fluid	SAE 20W-50 motor oil
Speeds @ 3400 rpm	Forward: 0-7 MPH (0-11,27 km/h) Reverse: 0-5 MPH (0-8,05 km/h)

DIMENSIONS

Models with 36" Mower Decks	
Overall Length	73-3/4" (187 cm)

Models with 36" Mower Decks	
Overall Width (with deflector up)	40-1/2" (103 cm)
Overall Width (with deflector down)	49-1/2" (126 cm)
Height	42-1/2" (108 cm)
Weight (Approx.)	732 lbs (332 kg)

Warranty

If your unit is equipped with a dual function hour meter that displays both engine hours and PTO hours, the warranty is based on the engine hours as displayed by the hour meter.

Warranty Statement

BRIGGS & STRATTON WARRANTY POLICY (January 2014)

LIMITED WARRANTY

Briggs & Stratton warrants that, during the warranty period specified below, it will repair or replace, free of charge, any part that is defective in material or workmanship or both.

Transportation charges on product submitted for repair or replacement under this warranty must be borne by purchaser. This warranty is effective for and is subject to the time periods and conditions stated below. For warranty service, find the nearest Authorized Service Dealer in our dealer locator map at ferrismowers.com. The purchaser must contact the Authorized Service Dealer, and then make the product available to the Authorized Service Dealer for inspection and testing.

There is no other express warranty. Implied warranties, including those of merchantability and fitness for a particular purpose, are limited to the warranty period listed below, or to the extent permitted by law. Liability for incidental or consequential damages are excluded to the extent exclusion is permitted by law. Some states or countries do not allow limitations on how long an implied warranty lasts, and some states or countries do not allow the exclusion or limitation of incidental or consequential damages, so the above limitation and exclusion may not apply to you. This warranty gives you specific legal rights and you may also have other rights which vary from state to state or country to country.**

WARRANTY PERIOD		
Covered Parts	Standard Warranty Period	Rental Warranty Period
Riding mowers - except as noted below +	4 years (48 months) or 500 hours, whichever occurs first. Unlimited hours during the first 2 years (24 months)	90 days
Walk mowers - except as noted below + (over 30 inches of cutting width)	2 years (24 months) unlimited hours	90 days
+Hydro Drive Belt, Gearbox Drive Belt, Tires, Brake Pads, Hoses, Battery, Blades	90 days	90 days
+Mower Deck Drive Belt (Conventional Single Belt Deck Drive Systems)	1 year (12 months) or 100 hours, whichever occurs first	90 days

+Mower Deck Drive Belts (Two Belt Deck Drive Systems)	3 years (36 months) or 300 hours, whichever occurs first. (Parts and labor in year one; parts only in years two and three.)	90 days
+Attachments	1 year	90 days
+Engine*	See Engine Operator's Manual	See Engine Operator's Manual

* Emissions-related components are covered by the Emissions Warranty Statement

** In Australia - Our goods come with guarantees that cannot be excluded under the Australian Consumer Law. You are entitled to a replacement or refund for a major failure and for compensation for any other reasonably foreseeable loss or damage. You are also entitled to have the goods repaired or replaced if the goods fail to be of acceptable quality and the failure does not amount to a major failure. For warranty service, find the nearest Authorized Service Dealer in our dealer locator map at ferrismowers.com (Select region: Australia), or by calling 1300 274 447, or by emailing or writing to salesenquires@briggsandstratton.com.au, Briggs & Stratton Australia Pty Ltd, 1 Moorebank Avenue, NSW, Australia, 2170.

The warranty period begins on the date of purchase by the first retail or commercial customer.

To ensure prompt and complete warranty coverage, register your product at the website shown above or at www.onlineproductregistration.com, or mail the completed registration card (if provided), or call 1-800-743-4115 (in USA).

Save your proof of purchase receipt. If you do not provide proof of the initial purchase date at the time warranty service is requested, the manufacturing date of the product will be used to determine the warranty period. Product registration is not required to obtain warranty service on Briggs & Stratton products.

ABOUT YOUR WARRANTY

Warranty service is available only through *Ferris* Authorized Service Dealers. This warranty only covers defects in materials or workmanship. It does not cover damage caused by improper use or abuse, improper maintenance or repair, normal wear and tear, or stale or unapproved fuel.

Improper Use and Abuse - The proper, intended use of this product is described in the Operator's Manual. Using the product in a way not described in the Operator's Manual or using the product after it has been damaged will not be covered under this warranty. Warranty coverage will also not be provided if the serial number on the product has been removed or the product has been altered or modified in any way, or if the product has evidence of abuse such as impact damage, or water/chemical corrosion damage.

Improper Maintenance or Repair - This product must be maintained according to the procedures and schedules provided in the Operator's Manual, and serviced or repaired using genuine Briggs & Stratton parts or equivalent. Damage caused by lack of maintenance or use of non-original or non-equivalent parts is not covered by warranty.

Normal Wear and Tear - Like all mechanical devices, the unit is subject to wear even when properly maintained. This warranty does not cover replacement or repairs when normal use has exhausted the life of a part or the equipment. Except as noted in the warranty period, maintenance and wear items such as filters, belts, cutting blades, and brake pads (except engine brake pads) are not covered by warranty due to wear characteristics alone, unless the cause is due to defects in material or workmanship.

Stale or Unapproved Fuel - In order to function correctly, this product requires fresh fuel that conforms to the criteria specified in the Operator's Manual. Engine or equipment damage caused by stale fuel or the use of unapproved fuels (such as E15 or E85 ethanol blends) is not covered by warranty.

Other Exclusions - This warranty excludes damage due to accident, abuse, modifications, alterations, improper servicing, freezing or chemical deterioration. Attachments or accessories that were not originally packaged with the product are also excluded. This warranty does not include used, reconditioned, second-hand, or demonstration equipment or engines. This warranty also excludes failures due to acts of God and other force majeure events beyond the manufacturer's control.

Not for
Reproduction

Not for
Reproduction

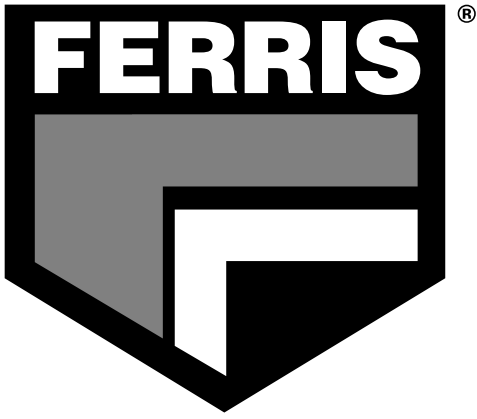

OPERATOR'S MANUAL

Not for
Reproduction