

SPECIFICATIONS

HL965

Tier 4 Final Engine



*Photo may include optional equipment.

Net Power

269 HP (198 kW) / 2,100 rpm

Operating Weight

20,730 kg / 45,700 lb

Standard Bucket

3.6 m³ / 4.7 yd³

 **HYUNDAI**
CONSTRUCTION EQUIPMENT

SPECIFICATIONS HL965

ENGINE	
Make/model	Cummins / QSL9
Type	Water-cooled, 4-cycle, turbocharged charge air-cooled, direct-injection, electronically controlled diesel engine.
Gross power	272 HP (200 kW) / 2,100 rpm
Net power	269 HP (198 kW) / 2,100 rpm
Maximum torque	148 Kg.m (1,070 lbs.ft) / 1,400 rpm
No. of cylinders	6
Bore x Stroke	114 mm (4.49") x 145 mm (5.69")
Displacement	8.9 l (543 in ³)
Compression ratio	17.8:1
Air cleaner	Dry, two-stage dual elements
Alternator	24 V - 95A
Battery	2 x 12 V, 900 CCA
Starting motor	24 V-7.85 kW

TRANSMISSION	
Torque converter type	3-elements, single-stage, single-phase
Tire	23.5 R25, L3

* Fully automatic power shift, countershaft type with soft-shift in range and direction. Properly matched torque converter to engine and transmission for excellent working ability

Travel speed, km/h (mph)	4 speed T/M	5 speed T/M with lockup clutch	
Forward	1st	6.0 (3.7)	6.3 (3.9)
	2nd	11.4 (7.1)	11.1 (6.9)
	3rd	22.9 (14.2)	17.1 (10.6)
	4th	37.4 (23.2)	26.6 (16.5)
	5th	–	40.0 (24.9)
Reverse	1st	6.3 (3.9)	6.7 (4.2)
	2nd	12.0 (7.5)	11.7 (7.3)
	3rd	24.2 (15.0)	28.0 (17.4)

AXLES	
Drive system	Four-wheel drive system
Mount	Rigid front axle and oscillating rear axle
Rear axle oscillation	Oscillation ±12° of center pin-loaded
Hub reduction	Planetary reduction at wheel end
Differential	Hydraulic Lock (front) / Conventional (rear)
Reduction ratio	27.0

OVERVIEW			
Description	UNIT	HL965	HL965XT
Operating weight	kg (lb)	20,730 (45,700)	20,960 (46,210)
Bucket capacity	Heaped	m ³ (yd ³)	3.6 (4.7)
	Struck	m ³ (yd ³)	3.1 (4.0)
Breakout force-bucket		kg (lb)	17,400 (38,360)
			17,265 (38,063)
Tipping load	Straight	kg (lb)	16,155 (35,615)
			13,400 (29,540)
	Full turn	kg (lb)	13,975 (30,810)
			11,520 (25,395)

TIRES	
Type	Tubeless, loader design tires
Standard	23.5 R25, L3
Options include	23.5 - 25, 20 PR, L3
	23.5 - R25, XHA2, L3
	20.5 - 25, 16 PR, L3

HYDRAULIC SYSTEM	
Type	Load-sensing hydraulic system
Pump	Variable-displacement piston pump, 249 l/min (66 gpm)
Control valve	2 spool (bucket, boom) 3 spool (bucket, boom, aux)
System pressure	280 kgf/cm ² (3,983 psi)
Lift circuit	The valve has four functions: raise, hold, lower and float. Can adjust automatic kick-out from horizontal to full lift.
Tilt circuit	The valve has three functions: tilt back, hold and dump. Can adjust automatic bucket positioner to desired load angle.
Cylinder	HL965 HL965XT Type: Double acting No. of cylinders-bore x stroke; Lift: 2-140 mm (5.5") x 785 mm (30.9") Tilt: 160 mm (6.3") x 560 mm (22")
Cycle time	Raise: 5.8 sec Dump: 1.4 sec Lower: 3.1 sec Total: 10.3 sec

BRAKES	
Service brakes	Hydraulically actuated, wet-disc brakes actuate all 4 wheels Independent axle-by-axle system Wheel speed brake
Parking brake	Spring-applied, hydraulically released brake
Emergency brake	When brake oil pressure drops, indicator light alerts operator and parking brake automatically applies

STEERING SYSTEM	
Type	Load-sensing hydrostatic articulated steering
Pump	Variable-displacement piston pump, 115 l/min (30 gpm)
Relief valve setting	250 kgf/cm ² (3,555 psi)
Cylinder	Double-acting 75 mm (2.9") X 424 mm (16.7")
Steering angle	40° both right and left angle, respectively
Additional features	Center-point frame articulation Tilt and telescopic steering column

SERVICE REFILL CAPACITIES	
Fuel tank	300 l (79.3 US gal)
DEF tank	27 l (7.1 US gal)
Cooling system	44 l (11.6 US gal)
Crankcase	19 l (5.0 US gal)
Transmission	33 l (8.7 US gal)
Front axle	42 l (11.1 US gal)
Rear axle	40 l (10.6 US gal)
Hydraulic tank	115 l (30.4 US gal)
Hydraulic system (including tank)	215 l (56.8 US gal)

DIMENSIONS

All dimensions are approximate.

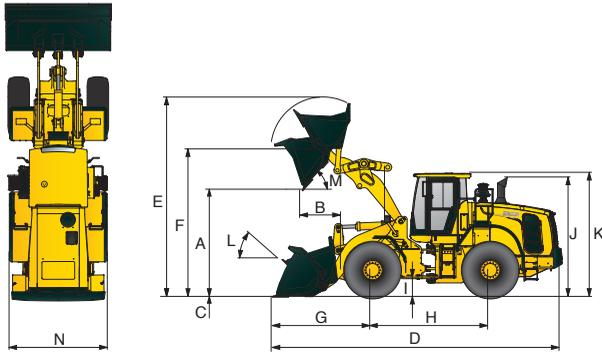

Description	UNIT	HL965	HL965XT
Bucket Type	General purpose bolt-on cutting edge		
A. Dumping clearance at max. height and 45° dump angle.	mm (ft-in)	2,955 (9' 8.3")	3,440 (11' 3.4")
B. Reach	Full lift	mm (ft-in)	1,400 (4' 7.1")
	2,134 mm height (7 feet)	mm (ft-in)	1,920 (6' 3.6")
C. Digging depth	mm (ft-in)	90 (0.3")	90 (0.3")
	D. Overall length	on ground	mm (ft-in)
	at carry	mm (ft-in)	8,195 (26' 10.6")
			8,850 (28' 0.6")

Description	UNIT	HL965	HL965XT
E. Overall height (fully raised)	mm (ft-in)	5,700 (18' 8.4")	6,185 (20' 3.5")
F. Bucket pivot max. height	mm (ft-in)	4,145 (13' 7")	4,630 (15' 2.3")
G. Front overhang	mm (ft-in)	2,900 (9' 6.1")	3,370 (11' 0.7")
H. Wheelbase	mm (ft-in)	3,300 (10' 9.9")	3,300 (10' 9.9")
I. Ground clearance	mm (ft-in)	410 (1' 4.1")	410 (1' 4.1")
J. Height over exhaust	mm (ft-in)	3,375 (11' 0.9")	3,375 (11' 0.9")
K. Height over cab	mm (ft-in)	3,450 (11' 3.9")	3,450 (11' 3.9")
L. Rollback angle	on ground	deg	42
	at carry	deg	47
M. Dump angle	deg	50	50
Clearance circle, over bucket (carry position)	mm (ft)	13,580 (44' 6.6")	14,040 (46' 0.8")
Clearance circle, outside of tires	mm (ft)	12,045 (39' 6.2")	12,045 (39' 6.2")
Clearance circle, inside of tires	mm (ft)	6,530 (21' 5")	6,530 (21' 5")
N. Overall width	with bucket	mm (ft-in)	3,000 (9' 10.1")
	without bucket	mm (ft-in)	2,770 (9' 1")
	without bucket	mm (ft-in)	2,770 (9' 1")

HL965 / DENSITY OF OPERATING MATERIALS

Material	Material Density
Loose material	
Earth/clay	1.5~1.7 tons / m ³ (2,528~2,865 lb / yd ³)
Sand and gravel	1.5~1.7 tons / m ³ (2,528~2,865 lb / yd ³)
Aggregate	mm (1" to 3")
	mm (3") and larger
	1.6~1.7 tons / m ³ (2,697~2,865 lb / yd ³)
	1.8 tons / m ³ (3,034 lb / yd ³)

HL965 / DENSITY OF OPERATING MATERIALS

Lift arm	Bucket	Type	m ³ (yd ³)	Material Density [tons / m ³]																			
				0.8 (1,349)	0.9 (1,517)	1.0 (1,686)	1.1 (1,854)	1.2 (2,023)	1.3 (2,191)	1.4 (2,360)	1.5 (2,528)	1.6 (2,697)	1.7 (2,865)	1.8 (3,034)	1.9 (3,203)	2.0 (3,371)	2.1 (3,540)	2.2 (3,708)	2.3 (3,878)	2.4 (4,046)	2.5 (4,215)		
Standard lift arm	General Purpose	Cutting edge	3.6 (4.7)	4.1 m ³ (5.4 yd ³)												3.4 m ³ (4.4 yd ³)							
		Cutting edge	3.8 (5.0)	4.4 m ³ (5.7 yd ³)												3.6 m ³ (4.7 yd ³)							
		1-Bolt on tooth	3.4 (4.4)	3.9 m ³ (5.1 yd ³)												3.2 m ³ (4.2 yd ³)							
		1-Bolt on tooth	3.6 (4.7)	4.1 m ³ (5.4 yd ³)												3.4 m ³ (4.4 yd ³)							
		2-Bolt on tooth	3.4 (4.4)	3.9 m ³ (5.1 yd ³)												3.2 m ³ (4.2 yd ³)							
		2-Bolt on tooth	3.6 (4.7)	4.1 m ³ (5.4 yd ³)												3.4 m ³ (4.4 yd ³)							
High lift arm (XT)	General Purpose	Cutting edge	3.6 (4.7)	4.1 m ³ (5.4 yd ³)												3.4 m ³ (4.4 yd ³)							
		Cutting edge	3.8 (5.0)	4.4 m ³ (5.7 yd ³)												3.6 m ³ (4.7 yd ³)							
		1-Bolt on tooth	3.4 (4.4)	3.9 m ³ (5.1 yd ³)												3.2 m ³ (4.2 yd ³)							
		1-Bolt on tooth	3.6 (4.7)	4.1 m ³ (5.4 yd ³)												3.4 m ³ (4.4 yd ³)							
		2-Bolt on tooth	3.4 (4.4)	3.9 m ³ (5.1 yd ³)												3.2 m ³ (4.2 yd ³)							
		2-Bolt on tooth	3.6 (4.7)	4.1 m ³ (5.4 yd ³)												3.4 m ³ (4.4 yd ³)							

CAB & INTERIOR	STD	OPT
Alternator, 95 Amp	•	
Alarms, audible and visual		
Air filter clogging	•	
Transmission error	•	
Battery voltage	•	
Brake oil pressure	•	
Engine oil pressure	•	
Parking brake	•	
Fuel level	•	
Hydraulic oil temperature	•	
Coolant temperature	•	
Transmission oil temperature	•	
Service brake oil pressure	•	
Coolant level	•	
Water in fuel	•	
Alarm, backup	•	
Batteries, PT		
900 CCA, 12V, (2)	•	
Gauges		
Engine coolant temperature	•	
Fuel level	•	
Speedometer	•	
Transmission oil temperature	•	
Horn, electric	•	
Indicator lights		
T/C lockup	•	
High beam	•	
Turn signal	•	
FNR joystick steering		•
Pilot cutoff	•	
LCD Display		
Clock and fault code	•	
Operating hour counter	•	
Engine rpm	•	
Transmission gear range	•	
Indicator	•	
Job time and distance	•	
Temperature (coolant, hydraulic oil, t/m oil)	•	
Lighting system		
LED dome light	•	
2 stop and taillights	•	
4 turn signals	•	
Brake lights (counterweight)	•	
2 headlights on front tower	•	
2 working lights on front roof	•	
4 working lights on front roof, 2 working lights on rear roof		•
4 working lights (2 xenon) on front roof, 2 working lights on rear roof		•
4 working lights (LED) on front roof, 2 working lights (LED) on rear roof		•
2 working lights on grill	•	
Switches		
Hazard	•	
Ignition	•	
Parking	•	
Battery master switch	•	
FNR	•	
Diff lock	•	
SCR cleaning / inhibit	•	
Secondary steering test		•
Pilot cutoff	•	
Integrated monitor switches		
Main light switch	•	
Work light switch	•	
Auto grease switch	•	
Quick coupler switch	•	
Ride control switch	•	
Work load switch	•	
Beacon lamp switch	•	
Rear wiper switch	•	
Mirror heat switch	•	
Auto position switch	•	
Fine modulation switch	•	

CAB & INTERIOR	STD	OPT
Cab (sound suppressed and pressurized) with		
Cigar lighter and ashtray	•	
Coat hook	•	
Automatic climate control		
Air conditioner and heater	•	
Defroster	•	
Intermittent wiper and washer, front and rear	•	
Seat		
3" retractable seat belt and adjustable air suspension (heated)	•	
Personal storage space		
Console box	•	
Holder, can and cup	•	
Rearview mirrors (1 inside)	•	
Rearview mirrors (2 outside)	•	
Rearview mirrors (2 outside, heated)	•	
Steering column, tilt and telescopic	•	
Steering wheel with knob	•	
Roller type sunshade (front window)	•	
Roller type sunshade (rear window)		•
Tinted safety glass	•	
One door cab	•	
Magazine pocket	•	
Pedals		
One accelerator pedal	•	
One brake pedal	•	
Dual-brake pedal		•
Radio / USB player	•	
Bluetooth	•	
Miracast	•	
Rubber floor mat	•	
Armrest	•	
24V to 12V DC converter (20 amps)	•	

ENGINE	STD	OPT
Engine, Cummins, QSL9		
Tier 4 Final / Stage 4	•	
Engine enclosure, lockable	•	
Fan guard	•	
Reversible cooling fan	•	
Fuel/water separator	•	
Antifreeze	•	
Clean emission module		
DOC and SCR	•	
Radiator	•	
Fuel warmer	•	
Coolant-level sight gauge	•	
Engine oil-level dipstick gauge	•	
3-stage air precleaner	•	
Air cleaner with auto dust eject	•	

POWER TRAIN	STD	OPT
Brakes: service, enclosed wet-disc	•	
Parking brake	•	
Torque converter	•	
Transmission F4 / R3, computer-controlled, electronic soft-shift, auto-shift and kick-down features included	•	
Transmission F5 / R3 with lockup clutch		•
Transmission oil sight level	•	
Transmission oil cooler	•	
Transmission oil cooler with thermostat		•
Hydraulic lock differential (front) / Conventional differential (rear)	•	
Front and rear axle coolers		•
Limited slip differential (front, rear)		•
Hydraulic lock differential (front) / Limited slip differential (rear)		•

POWER TRAIN	STD	OPT
Tires		
23.5 R25, L3	•	
23.5-25, 20 PR, L3		•
23.5-R25, XHA2, L3		•
20.5-25, 16PR, L3		•
Travel speed limiter (20-40 km/h)	•	

HYDRAULIC SYSTEM	STD	OPT
Boom kick-out, automatic	•	
Bucket positioner, automatic	•	
Diagnostic pressure taps	•	
Hydraulic oil cooler	•	
Hydraulic control, 3 spool	•	
Joystick control (EH control)	•	
Fingertip control (EH control)		•
Joystick steering		•
Ride control system	•	
Secondary steering system		•
Extra piping for auxiliary function		•
Quick coupler piping	•	
Auto grease system		•

OTHER	STD	OPT
Articulation locking bar	•	
Counterweight	•	
Additional counterweight		•
Door and cab locks, one key	•	
Doors, service access (locking)	•	
Drawbar with pin	•	
Ergonomically located and slip-resistant, left and right	•	
Handrails	•	
Ladders	•	
Platforms	•	
Steps	•	
Hydraulic oil-level sight gauge	•	
Lift and tie-down hooks	•	
Loader linkage, sealed	•	
Z-bar design	•	
Vandalism protection caplocks	•	
Tool kit		•
Tooth, 1 piece, bolt-on type		•
Tooth, 2 pieces, bolt-on type		•
Cutting edge, bolt-on type	•	
Quick coupler		•
Guards		
Crankcase		•
Transmission		•
Half fenders front and rear	•	
Full rear fenders		•
Wheel chock		•
License plate and lamp		•
Hi-mate remote management system		
Mobile	•	
Satellite		•

* Standard and optional equipment may vary. Contact your Hyundai dealer for more information. The machine may vary according to International standards.

* The photos may include attachments and optional equipment that are not available in your area.

* Materials and specifications are subject to change without advance notice.

* All imperial measurements rounded off to the nearest pound or inch.



www.hceamericas.com
6100 Atlantic Blvd., Norcross, GA 30071
TEL (678) 823-7777 FAX (678) 823-7778

PLEASE CONTACT