

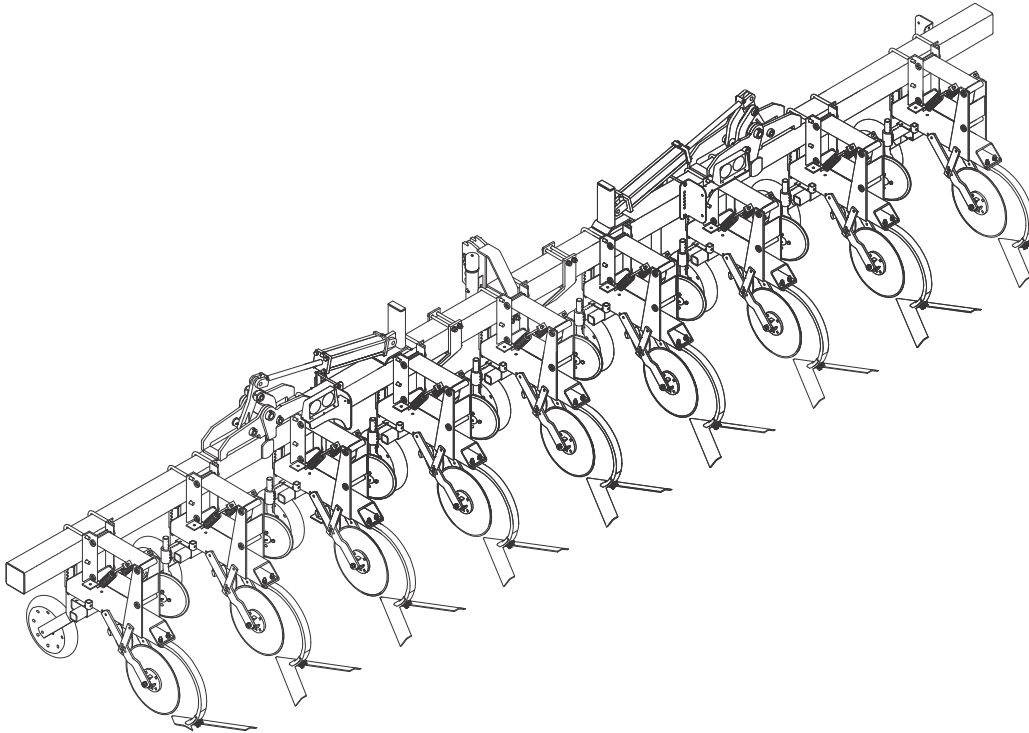

Model 2000 Series Row Crop Cultivator Operator's Manual



LANDOLL CORPORATION

1900 North Street
Marysville, Kansas 66508
(785) 562-5381

800-428-5655 ~ WWW.LANDOLL.COM

Table of Contents

1	Introduction	
	Understanding Safety Statements	1-2
2	Standard Specifications	
3	Assembly Instructions	
	Assembly Preparation	3-1
	Wing Fold Plumbing Installation	3-2
	Disc Installation	3-4
	Gauge Wheel Installation	3-5
	Shank Assembly	3-6
	Coulter Blade Installation	3-7
	Shields	3-8
	Ridgers	3-9
	Anhydrous Ammonia Knives	3-9
	Fertilizer Tubes	3-9
	Lift Assist Wheel	3-10
	Spray Nozzle Mount Attachment	3-11
	Nurse Tank Hitch Assembly	3-12
	Decal Placement	3-14
4	Operation and Maintenance	
	Tractor Preparation	4-2
	Cultivator Preparation	4-2
	Attaching To Three Point Hitch	4-2
	Initial Setup	4-3
	Field Operation	4-4
	Gauge Wheel Adjustment	4-5
	Coulter Adjustment	4-5
	Disc Adjustment	4-7
	Disc Bearing Maintenance	4-7
	Tool Frame	4-8

Ridgers and Knives	4-8
Shields	4-9
Lift Assist Wheel	4-9
Tool Hold Down Springs	4-10
Hydraulic Maintenance	4-10
Lubrication	4-10
Storage	4-11

5 Troubleshooting Guide

Chapter 1

Introduction

The Landoll Model 2000 Series Row Crop Cultivator is a quality product designed to give years of trouble free performance. By following each section of this manual, your system will perform as designed for you and your operation

- CHAPTER 1** gives basic instructions on the use of this manual.
- CHAPTER 2** gives product specifications. These specifications supply lengths and measures for your equipment. A Standard Bolt Torque Table is provided to give guidelines for bolt torques to be used when servicing this product.
- CHAPTER 3** contains assembly instructions for your Model 2000 Series Row Crop Cultivator. When these procedures are correctly followed, your equipment should provide you years of trouble-free operation and service.
- CHAPTER 4** instructs how to operate your equipment before using it, and describes adjustments needed. It also gives practical advice for the care and maintenance of your Landoll equipment. Drawings in this section locate adjustment points on the equipment.
NOTE: IF THE EQUIPMENT IS IMPROPERLY ASSEMBLED OR MAINTAINED, THE WARRANTY IS VOID. IF YOU HAVE ANY QUESTIONS CONTACT:
LANDOLL CORPORATION
1900 NORTH STREET
MARYSVILLE, KANSAS 66508
or phone:
(785) 562-5381 or
(800) 428-5655
(888) 527-3909
- CHAPTER 5** is a troubleshooting guide to aid in diagnosing and solving problems with the equipment.
- PARTS LIST** is a separate manual showing the various assemblies, subassemblies, and systems. Refer to that manual when ordering Landoll replacement parts. Order parts from your Landoll dealer.
- WARRANTY** The Warranty Registration form is included with the product documents. Fill it out and mail it within 15 days of purchase.
NOTE: IMPROPER ASSEMBLY, MODIFICATION, OR MAINTENANCE OF YOUR LANDOLL MACHINE CAN VOID YOUR WARRANTY.
- COMMENTS** Address comments or questions regarding this publication to:
LANDOLL CORPORATION
1900 NORTH STREET
MARYSVILLE, KANSAS 66508
ATTENTION: PUBLICATIONS -DEPT. 55

Understanding Safety Statements

You will find various types of safety information on the following pages and on the machine signs (decals) attached to the vehicle. This section explains their meaning.

The Safety Alert Symbol means ATTENTION! YOUR SAFETY IS INVOLVED!



DANGER

Danger means a life-threatening situation exists. Death can occur if safety measures or instructions on this label are not properly followed.



WARNING

Warning means serious injury or death can occur if safety measures or instructions on this label are not properly followed.



CAUTION

Caution means serious equipment or other property damage can occur if instructions on this label are not properly followed.

NOTE

Means that failure to follow these instructions could cause damage to the equipment or cause it to operate improperly.

NOTE

Make sure you read and understand the information contained in this manual and on the machine signs (decals) before you attempt to operate or maintain this vehicle.

The safety statements contained in this manual relate to the operation of the Model 2000 Series Row Crop Cultivator.

Standard Specifications

2000 SERIES ROW CROP CULTIVATOR RIGID MODELS						
MODEL NO.	NO. OF ROWS	TRANSPORT WIDTH	NO. OF SHANKS	NO. OF COULTERS	SHANK SPACING	ESTIMATED WEIGHT (LBS.)
2004-30HC-94	4	11'-0"	5	5	30"	2,100
2004-36HC-94	4	13'-8"	5	5	36" - 38"	2,225
2006-30HC-94	6	16'-0"	7	7	30"	3,000
2006-36HC-94	6	20'-0"	7	7	36" - 38"	3,131
2008-30HC-94	8	21'-0"	9	9	30"	3,872
2008-36HC-94	8	26'-4"	9	9	36" - 38"	4,046
2008-40HC-94	8	27'-8"	9	9	40"	4,070
2010-30HC-94	10	26'-0"	11	11	30"	5,500

2000 SERIES ROW CROP CULTIVATOR FOLD MODELS						
MODEL NO.	NO. OF ROWS	TRANSPORT WIDTH	NO. OF SHANKS	NO. OF COULTERS	SHANK SPACING	ESTIMATED WEIGHT (LBS.)
2006-36HCF-94	6	15'-4"	7	7	36" - 38"	3,989
2008-30HCF-94	8	12'-7"	9	9	30"	4,730
2008-36HCF-94	8	15'-4"	9	9	36" - 38"	4,905
2008-40HCF-94	8	16'-8"	9	9	38" - 40"	5,035
2010-30HCF-94	10	17'-5"	11	11	30"	5,900
2010-38HCF-94	10	17'-2"	11	11	38"	6,200
2012-30HCF-94	21	17'-7"	13	13	30"	6,700
2012-36HCF-94	12	21'-8"	13	13	36"	8,151
2012-38HCF-94	12	23'-8"	13	13	38"	8,171
2012-40HCF-94	12	_____	13	13	40"	8,191
2016-30HCF-94	16	22'-7"	17	17	30"	8,663

STANDARD SPECIFICATIONS

LANDOLL CORPORATION GENERAL TORQUE SPECIFICATIONS (REV. 4/97)

THIS CHART PROVIDES TIGHTENING TORQUES FOR GENERAL PURPOSE APPLICATIONS WHEN SPECIAL TORQUES ARE NOT SPECIFIED ON PROCESS OR DRAWING.

ASSEMBLY TORQUES APPLY TO PLATED NUTS AND CAPSCREWS ASSEMBLED WITHOUT SUPPLEMENTAL LUBRICATION (AS RECEIVED CONDITION). THEY DO NOT APPLY IF SPECIAL GRAPHITE MOLY-DISULFIDE OR OTHER EXTREME PRESSURE LUBRICANTS ARE USED.

WHEN FASTENERS ARE DRY (SOLVENT CLEANED), ADD 33% TO AS RECEIVED CONDITION TORQUE.

BOLT HEAD IDENTIFICATION MARKS INDICATE GRADE AND MAY VARY FROM MANUFACTURER TO MANUFACTURER.

THICK NUTS MUST BE USED ON GRADE 8 CAPSCREWS.

USE VALUE IN [] IF USING PREVAILING TORQUE NUTS.

TORQUE IS SPECIFIED IN FOOT POUNDS

UNC Size	SAE Grade 2		SAE Grade 5		SAE Grade 8		UNF Size	SAE Grade 2		SAE Grade 5		SAE Grade 8	
1/4-20	4	[5]	6	[7]	9	[11]	1/4-28	5	[6]	7	[9]	10	[12]
5/16-18	8	[10]	13	[16]	18	[22]	5/16-24	9	[11]	14	[17]	20	[25]
3/8-16	15	[19]	23	[29]	35	[43]	3/8-24	17	[21]	25	[31]	35	[44]
7/16-14	24	[30]	35	[43]	55	[62]	7/16-20	27	[34]	40	[50]	60	[75]
1/2-13	35	[43]	55	[62]	80	[100]	1/2-20	40	[50]	65	[81]	90	[112]
9/16-12	55	[62]	80	[100]	110	[137]	9/16-18	60	[75]	90	[112]	130	[162]
5/8-11	75	[94]	110	[137]	170	[212]	5/8-18	85	[106]	130	[162]	180	[225]
3/4-10	130	[162]	200	[250]	280	[350]	3/4-16	150	[188]	220	[275]	320	[400]
7/8-9	125	[156]	320	[400]	460	[575]	7/8-14	140	[175]	360	[450]	500	[625]
1-8	190	[237]	408	[506]	680	[850]	1-14	210	[263]	540	[675]	760	[950]
1-1/8-7	270	[337]	600	[750]	960	[1200]	1-1/8-12	300	[375]	660	[825]	1080	[1350]
1-1/4-7	380	[475]	840	[1050]	1426	[1782]	1-1/4-12	420	[525]	920	[1150]	1500	[1875]
1-3/8-6	490	[612]	110	[1375]	1780	[2225]	1-3/8-12	560	[700]	1260	[1575]	2010	[2512]
1-1/2-6	650	[812]	1460	[1825]	2360	[2950]	1-1/2-12	730	[912]	1640	[2050]	2660	[3325]
1-3/4-5	736	[920]	1651	[2063]	2678	[3347]	1-3/4-12	920	[1150]	2063	[2579]	3347	[4183]

METRIC

COARSE THREAD METRIC CLASS 10.9 FASTENERS AND CLASS 10.0 NUTS AND THROUGH HARDENED FLAT WASHERS, PHOSPHATE COATED, ROCKWELL "C" 38-45.

USE VALUE IN [] IF USING PREVAILING TORQUE NUTS.

Nominal Thread Diameter mm	Standard Torque		Nominal Thread Diameter mm	Standard Torque	
	Newton-Meters	Foot-Pounds		Newton-Meters	Foot-Pounds
6	10	[14]	7	10	[14]
7	16	[22]	12	16	[22]
8	23	[32]	17	24	[32]
10	46	[60]	34	47	[60]
12	80	[101]	60	75	[101]
14	125	[155]	90	115	[155]
16	200	[240]	150	180	[240]
18	275	[330]	205	245	[330]

Table 2-1: General Torque Specifications

**LANDOLL CORPORATION
HYDRAULIC FITTING TORQUE SPECIFICATIONS
37° JIC, ORS, & ORB (REV. 10/97)**

THIS CHART PROVIDES TIGHTENING TORQUES FOR HYDRAULIC FITTING APPLICATIONS WHEN SPECIAL TORQUES ARE NOT SPECIFIED ON PROCESS OR DRAWING.

ASSEMBLY TORQUES APPLY TO PLATED CARBON STEEL AND STAINLESS STEEL FITTINGS ASSEMBLED WITHOUT SUPPLEMENTAL LUBRICATION (AS RECEIVED CONDITION). THEY DO NOT APPLY IF SPECIAL GRAPHITE MOLY-DISULFIDE OR OTHER EXTREME PRESSURE LUBRICANTS ARE USED. BRASS FITTINGS AND ADAPTERS - 65% OF THE TORQUE VALUE FOR STEEL. STAINLESS STEEL, ALUMINUM AND MONEL - THREADS ARE TO BE LUBRICATED.

TORQUE IS SPECIFIED IN FOOT POUNDS

PARKER BRAND FITTINGS			
Dash Size	37 Degree JIC	O-Ring (ORS)	O-Ring Boss (ORB)
-4	11-13	15-17	13-15
-5	14-16	—	21-23
-6	20-22	34-36	25-29
-8	43-47	58-62	40-44
-10	55-65	100-110	57.5-62.5
-12	80-90	134-146	75-85
-16	115-125	202-218	109-121
-20	160-180	248-272	213-237
-24	185-215	303-327	238-262
-32	250-290	—	310-340
GATES BRAND FITTINGS			
Dash Size	37 Degree JIC	O-Ring (ORS)	O-Ring Boss (ORB)
-4	10-11	10-12	14-16
-5	13-15	—	—
-6	17-19	18-20	24-26
-8	34-38	32-40	37-44
-10	50-56	46-56	50-60
-12	70-78	65-80	75-83
-14	—	65-80	—
-16	94-104	92-105	111-125
-20	124-138	125-140	133-152
-24	156-173	150-180	156-184
-32	219-243	—	—
AEROQUIP BRAND FITTINGS			
Dash Size	37 Degree JIC	O-Ring (ORS)	O-Ring Boss (ORB)
-4	11-12	10-12	14-16
-5	15-16	—	18-20
-6	18-20	18-20	24-26
-8	38-42	32-35	50-60
-10	57-62	46-50	72-80
-12	79-87	65-70	125-135
-14	—	—	160-180
-16	108-113	92-100	200-220
-20	127-133	125-140	210-280
-24	158-167	150-165	270-360
-32	245-258	—	—

Table 2-2: Hydraulic Fitting Torque Specifications

Assembly Instructions

It is very important that your new 2000 Series Row Crop Cultivator be properly assembled, adjusted and lubricated before use. Illustrations to assist with the assembly process are provided in **Section 2, “Standard Specifications”**. They show proper shank, disc gang and mounting bracket spacings. Illustrations in this section show proper assembly procedures. Remove paint from grease fittings. Replace any grease fittings that are damaged or missing. Be sure to return screws, clips, etc., to their original locations.

To insure alignment of assemblies, **leave the nuts loose until completion** of final assembly. Use split lock washers or flat washers as specified. Spread all cotter pins.

After completion of final assembly, **tighten all nuts evenly** to prevent misalignment, distortion or binding. Tighten all screws and nuts to the recommended torques shown in **Table 2-1**.



DANGER

To prevent accidental lowering:

1. All hydraulically elevated equipment must be locked out using the cylinder lockouts:
2. Lower equipment to the ground while servicing or when it is idle.

Failure to take measures to prevent accidental lowering may result in serious personal injury or death.



CAUTION

Be sure to bleed the hydraulic system of all air in lines after installation. Failure to bleed the system of all air can result in permanent equipment damage.



DANGER

Coulter blades are extremely sharp. Exercise extreme care when working on or near disc blades. Do not allow discs to roll over or fall onto any bodily part. Do not allow wrenches to slip when working near disc blades. Never push wrenches toward disc blades. Do not climb over machine above disc blades. Failure to stay clear of disc blade edges can cause serious personal injury or death.



WARNING

Do not attempt to lift heavy parts (such as the frame, disc gangs, rock shaft, and pull hitch) manually. Use a hoist or a fork lift to move these parts into position.



DANGER

Never stand under or near the hydraulic folding wings during folding or unfolding operations. The wings can drop very quickly resulting in serious injury or death to anyone under or near the cultivator wings.

Assembly Preparation

1. Hook up the cultivator to a tractor using the three-point hitch. Raise the cultivator about 36" and place stands under the main frame to prevent accidental lowering.

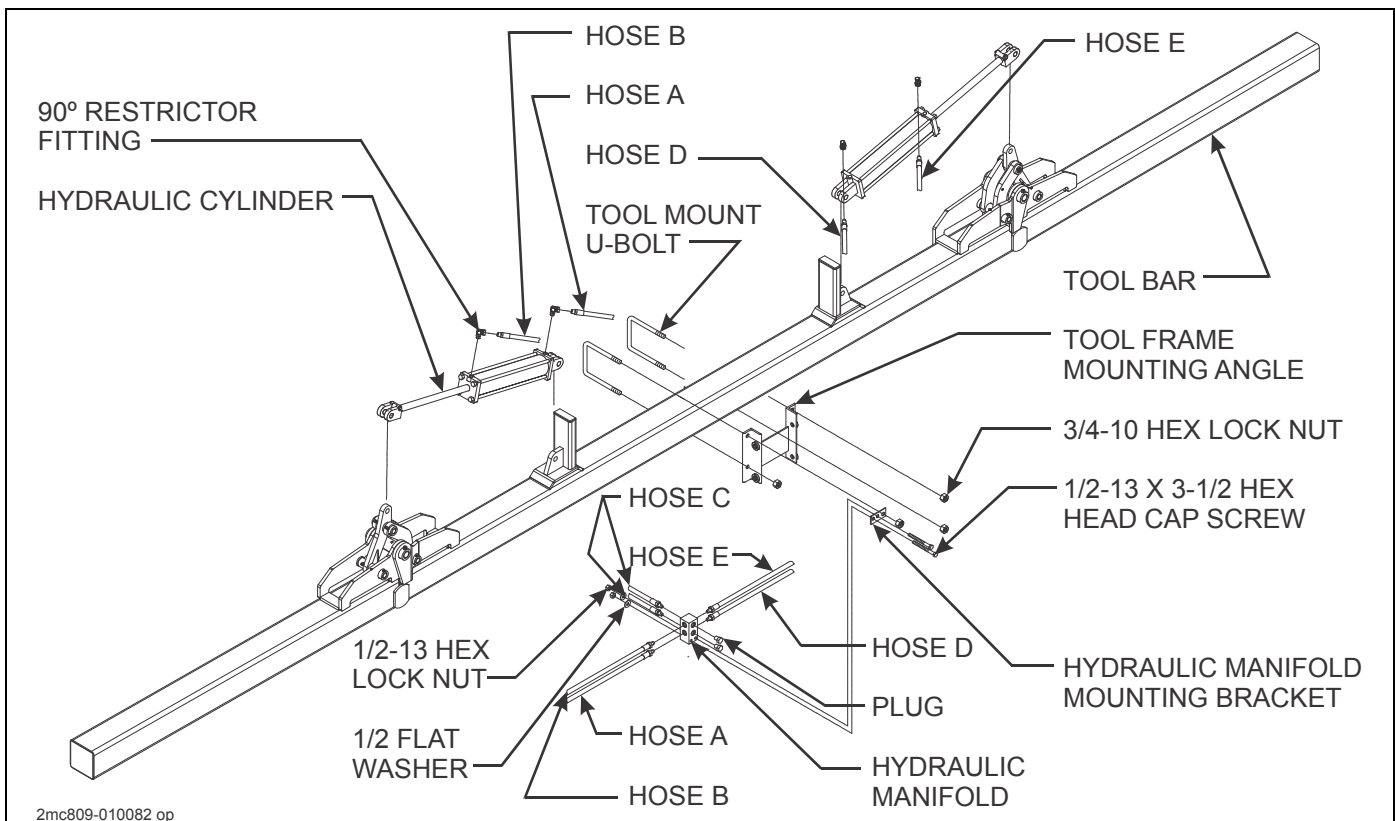

Figure 3-1: Hydraulic Installation

Wing Fold Plumbing Installation

IMPORTANT

See Figure 3-1 and Table 3-1 for parts names. When assembly is done, tighten all fastening hardware to the torques listed in Table 2-1 and Table 2-2. Tighten u-bolts evenly to show an even amount of thread on both legs of the u-bolt.

- Assemble the base of each cylinder to a cylinder base mount. Secure each with a clevis pin and the hairpin clips that come with the cylinders. Be sure the cylinders are set with the hose ports on the top when installation is done.
- Assemble the rod end of each cylinder to the top of the inner hinge arms. Secure each with the clevis pins and the hairpin clips given with the cylinders.
- Install the hydraulic manifold mounting bracket on the upper leg of the left-hand U-bolt on the center tool frame (See Figure 3-1.)
- Assemble the hydraulic manifold to the manifold mounting bracket using bolts and nuts provided (See Figure 3-1.)
- Insert Hose B with a 90° fitting to the base end of the left-hand cylinder. Insert the other end to the bottom hole in the left-hand side of the hydraulic manifold.
- Insert Hose A with a 90° fitting to the rod end of the left-hand cylinder. Insert the other end of the hose to the top hole in the left-hand side of the hydraulic manifold.
- Insert Hose D with a 90° fitting to the base end of the right-hand cylinder. Insert the other end to the bottom hole in the right-hand side of the hydraulic manifold.
- Insert Hose E with a 90° fitting to the rod end of the right-hand cylinder. Insert the other end of the hose to the top hole in the right-hand side of the hydraulic manifold.
- Insert coupling Hoses C (2 hoses supplied - 48" long on all models, coupler fittings are owner supplied) to the holes in the front of the hydraulic manifold. Connect the coupler fittings to the tractor.
- Lift the cultivator clear of the stands. Leave the stands under the main frame bar to prevent accidental lowering.
- Cycle the wing fold through several cycles to completely charge the hoses and cylinders with hydraulic oil. The hydraulic system must be free of air to keep movement of the wings in control during folding or unfolding. Add oil as needed to the tractor hydraulic system.

2000 SERIES HYDRAULIC HOSE TABLE			
ITEM	PART NUMBER	HOSE LENGTH	USED ON MODEL
A	1-397-010299-14	24"	2008-30HCF-94
	1-397-010299-15	48"	2006-36HCF-94, 2008-36HCF-94, 2008-40HCF-94
	1-397-010299-06	56"	2010-30HCF-94, 2010-30HCFLG-94, 2012-30HCF-94
	1-397-010299-12	84"	2010-36HCF-94, 2010-38HCF-94, 2012-36HCF-94, 2012-40HCF-94, 2016-30HCF-94
	1-397-010299-19	90"	2012-38HCF-94
B	1-397-010299-15	48"	2008-30HCF-94
	1-397-010299-13	74"	2008-40HCF-94
	1-397-010299-18	68"	2006-36HCF-94, 2008-36HCF-94
	1-397-010299-17	78"	2010-30HCF-94, 2010-30HCFLG-94, 2012-30HCF-94
	1-397-010299-20	108"	2010-36HCF-94, 2010-38HCF-94, 2012-36HCF-94, 2012-40HCF-94, 2016-30HCF-94
	1-397-010299-21	120"	2012-30HCF-94
C	1-397-010299-15	48"	ALL FOLD MODELS
D	1-397-010299-01	36"	2008-30HCF-94
	1-397-010299-02	60"	2006-36HCF-94, 2008-36HCF-94, 2008-40HCF-94
	1-397-010299-18	68"	2010-30HCF-94, 2010-30HCFLG-94, 2012-30HCF-94
	1-397-010299-22	98"	2010-36HCF-94, 2010-38HCF-94, 2012-36HCF-94, 2012-40HCF-94, 2016-30HCF-94
	1-397-010299102	102"	2012-38HCF-94
E	1-397-010299-02	60"	2008-30HCF-94
	1-397-010299-24	80"	2006-36HCF-94, 2008-36HCF-94
	1-397-010299-19	90"	2010-30HCF-94, 2010-30HCFLG-94, 2012-30HCF-94
	1-397-010299-21	120"	2010-36HCF-94, 2010-38HCF-94, 2012-36HCF-94, 2012-40HCF-94, 2016-30HCF-94
	1-397-010299126	126"	2012-38HCF-94

Table 3-1: Hydraulic Hose Installation for 2000 Series Row Crop Cultivator

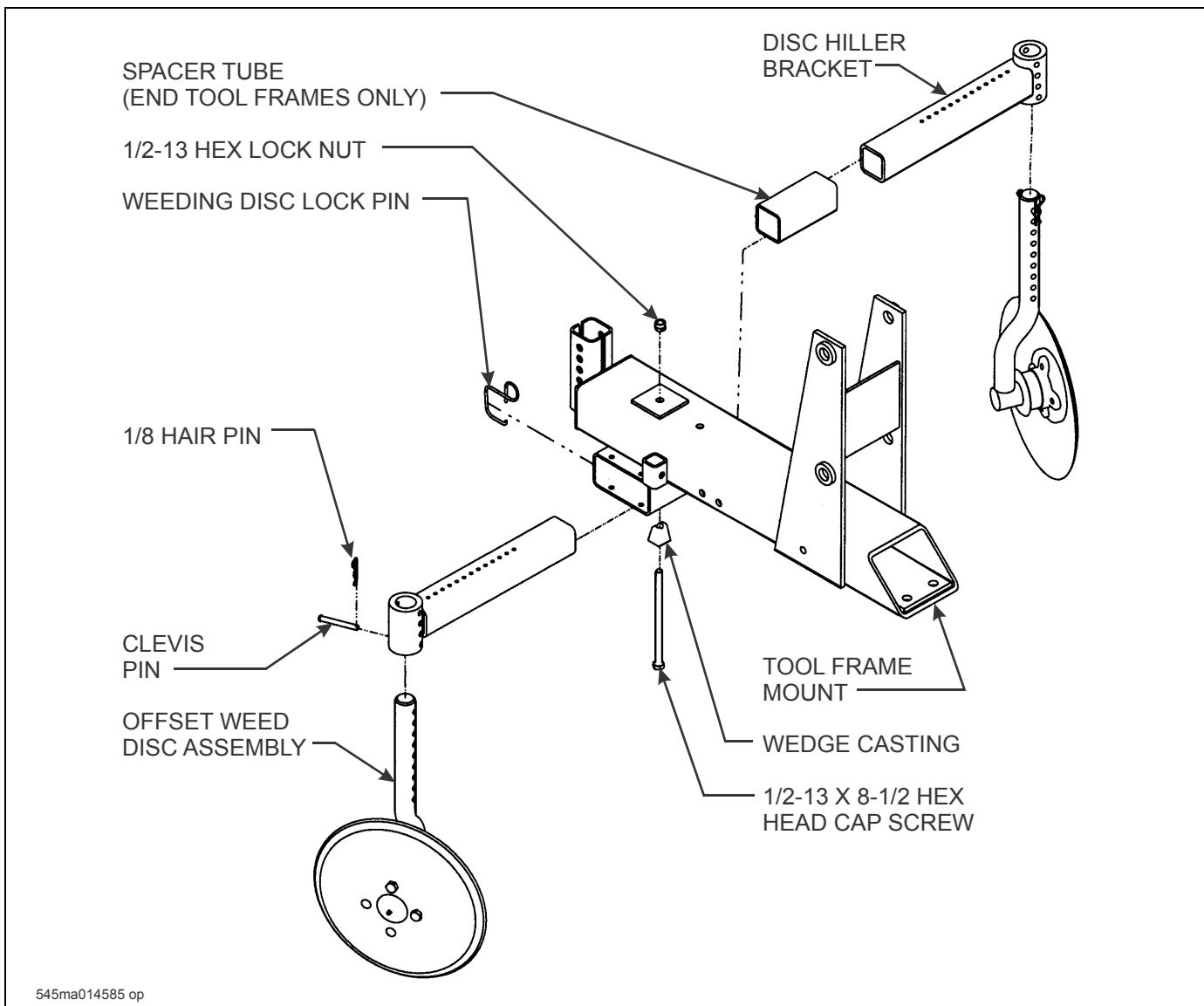

Figure 3-2: Disc Installation

Disc Installation

IMPORTANT

See Figure 3-2 for parts names. When assembly is done, tighten all fastening hardware to the torques listed in Table 2-1 and Table 2-2. Tighten u-bolts evenly to show an even amount of thread on both legs of the u-bolt.

IMPORTANT

The outer tool frames have a disc blade only on the inside of the tool frame. The outside has a spacer tube installed instead of the disc hiller bracket.

1. Remove the clevis pin and hair pin from each disc hiller bracket.
2. Insert a disc blade and spindle assembly through each disc hiller bracket to the desired depth. Reinstall the clevis pin and hair pin.

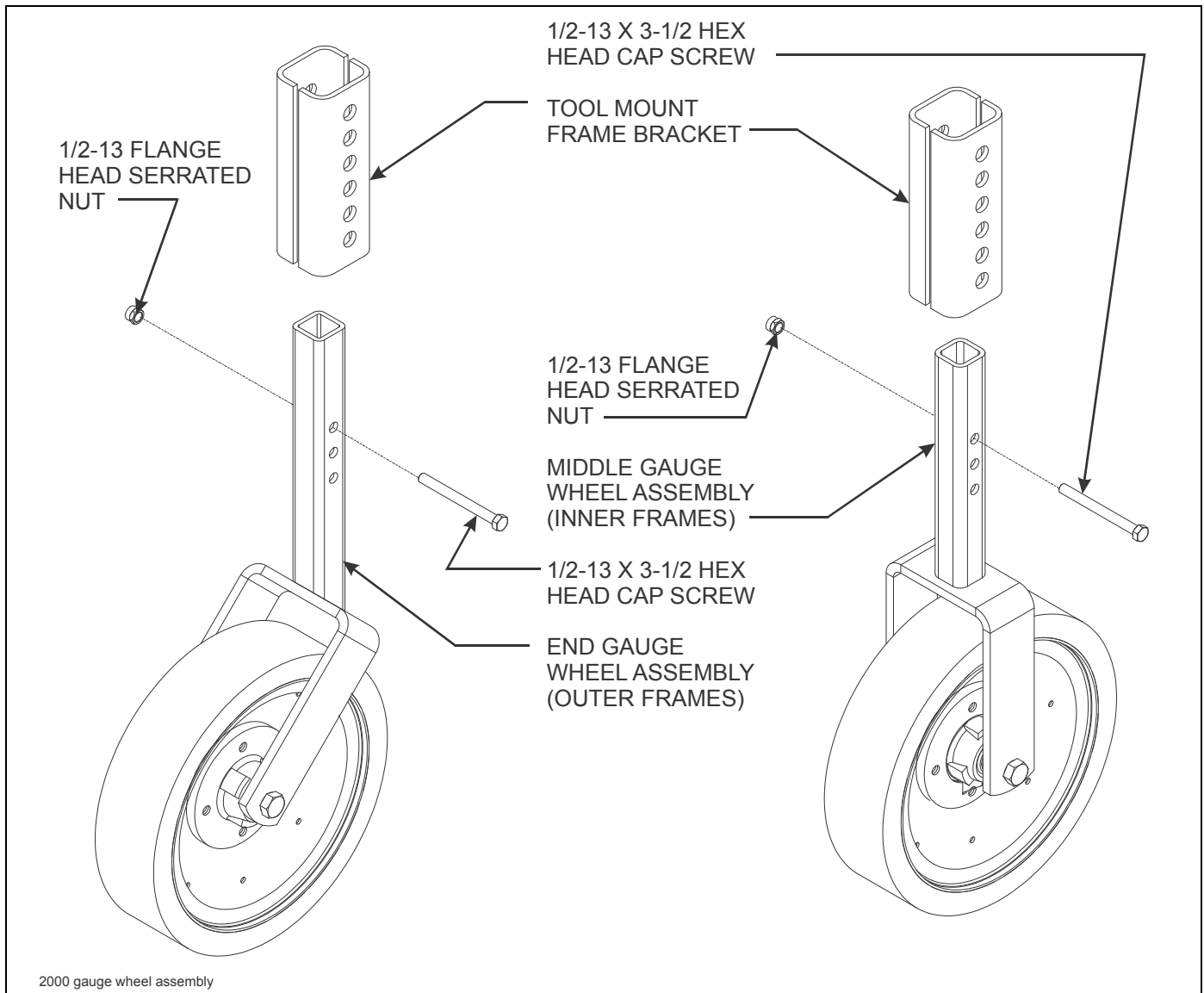

Figure 3-3: Gauge Wheel Installation

Gauge Wheel Installation

IMPORTANT

See Figure 3-3 for parts names. When assembly is done, tighten all fastening hardware to the torques listed in Table 2-1 and Table 2-2. Tighten u-bolts evenly to show an even amount of thread on both legs of the u-bolt.

1. Find the end gauge wheel assemblies with the 45° angle mounting forks.
2. Remove the 1/2-13 X 3-1/2 hex head cap screw and serrated flange head nut from the gauge wheel brackets. These are on the front of the outer tool frames.
3. Slide a gauge wheel square tube up through the bracket on each outer tool frame with the forks pointing forward. Position the gauge wheel for proper depth. Use the 1/2-13 X 3-1/2 hex head cap screw and serrated flange head nut to position the gauge wheel. Tighten the nut until wheel tube is securely clamped into place.
4. The remaining middle gauge wheel assemblies are installed on the inner tool frames. They are installed using the steps described in **steps 2 through 3**.

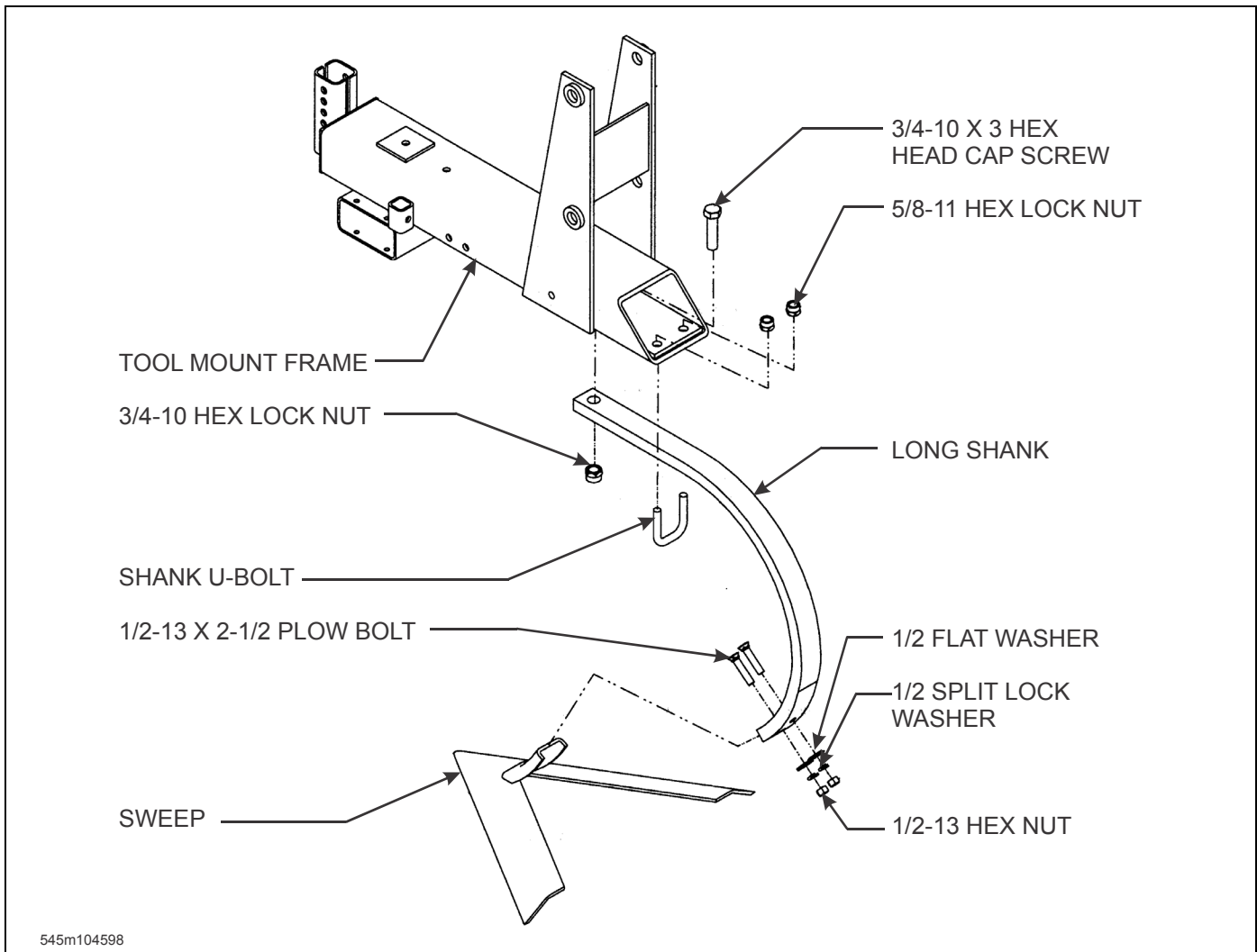

Figure 3-4: Shank Installation

Shank Assembly

IMPORTANT

See Figure 3-4 for parts names. When assembly is done, tighten all fastening hardware to the torques listed in Table 2-1 and Table 2-2. Tighten u-bolts evenly to show an even amount of thread on both legs of the u-bolt.

1. Assemble the sweeps and half sweeps to the shanks using 1/2-13 X 2-1/2 plow bolts, flat washer, split lock washer, and nuts. Install spacer washers between the shank and the sweep, as needed, to get desired penetration angle.

IMPORTANT

If the optional shields are to be used, the shield mounting brackets should now be installed (See Section 4, "Operation and Maintenance" for operation and maintenance procedures.)

2. Position the shank with the right-hand sweep (the half sweep with the right-hand wing) under the rear of the left end tool frame. Secure it with the shank u-bolt and 5/8-11 hex lock nuts, and a 3/4-10 X 3 hex head cap screw and hex lock nut.
3. Position the shank with the left-hand sweep (the half sweep with the left-hand wing) under the rear of the right most tool frame. Secure it with the shank u-bolt and 5/8-11 hex lock nuts, and a 3/4-10 X 3 hex head cap screw and hex lock nut.
4. Install the remainder of the shanks (with full sweeps) on the inner tool frames the same way as the end shanks described above.

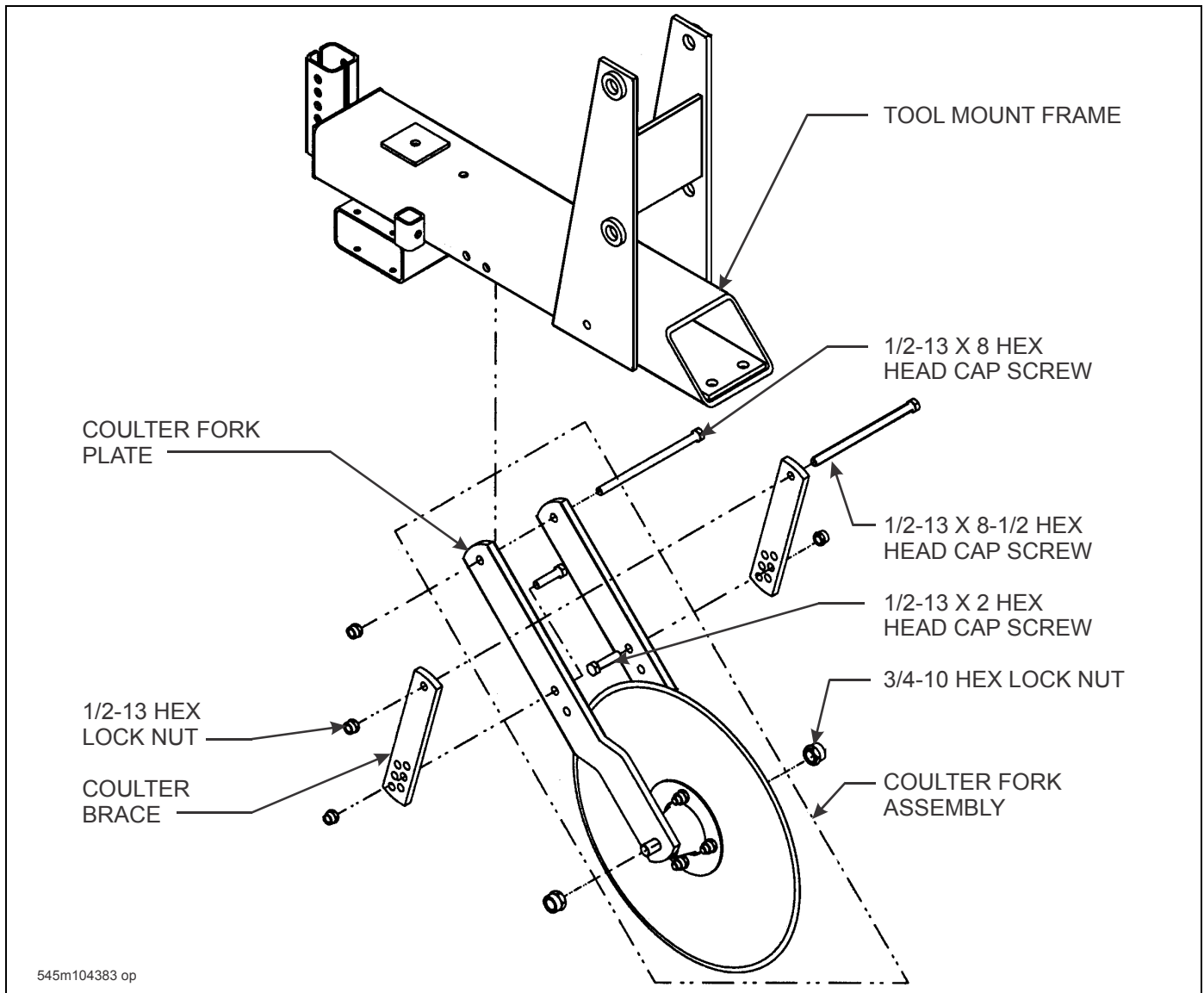

Figure 3-5: Coultter Blade Installation

Coultter Blade Installation

IMPORTANT

See Figure 3-5 for parts names. When assembly is done, tighten all fastening hardware to the torques listed in Table 2-1 and Table 2-2. Tighten u-bolts evenly to show an even amount of thread on both legs of the u-bolt.

1. Loosely assemble a coultter brace to the outer sides of each coultter fork with 1/2-13 X 2 hex head cap screws and hex lock nuts (Figure 3-5 shows proper mounting position.)
2. Loosely assemble each coultter fork assembly to a tool frame with a 1/2-13 X 8 hex head cap screw inserted through the coultter fork side, the tool frame, and the other coultter fork side, secured with a locking nut (Figure 3-5 shows proper mounting position.)
3. Loosely attach the coultter braces to the tool frames by inserting a 1/2-13 X 8-1/2 hex head cap screw through one brace, the tool frame, and through the other brace. Secure them with 1/2-13 hex lock nuts.
4. Leave all attaching hardware loose until final adjustments are made (See "Initial Setup" on page 4-3 for operation and maintenance procedures.)

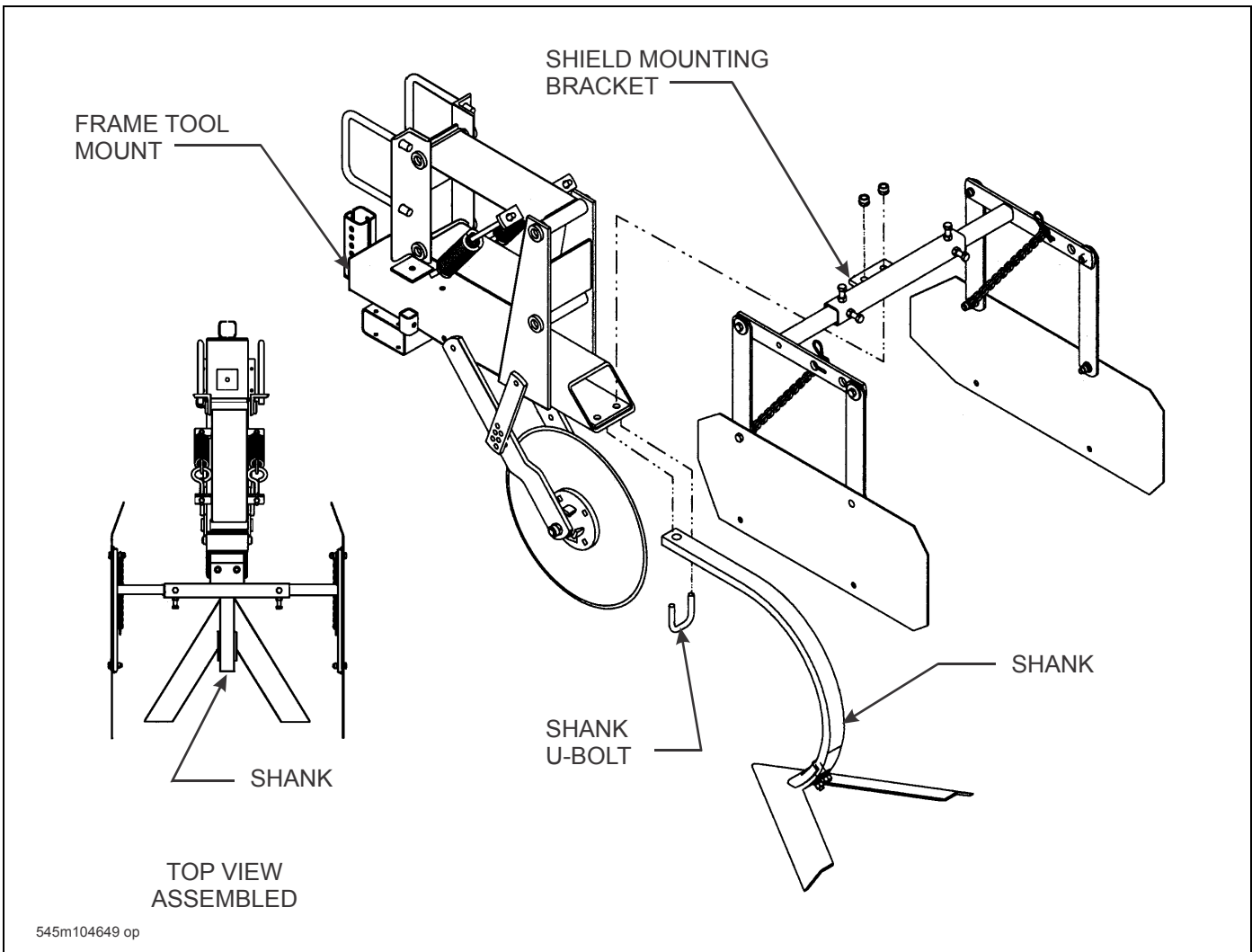

Figure 3-6: Shield Installation (Option)

Shields

1. Mount the shield bracket centered over the shank (See Figures 3-4 and 3-6) during shank installation. (See “Shank Assembly” on page 3-6.)
2. Install the shank u-bolt over the shank, through the frame tool mount and the shield mounting bracket. Secure with 5/8-11 hex lock nuts.

IMPORTANT

The outer end tool frames only have a half shield, found on the inside of the tool assembly.

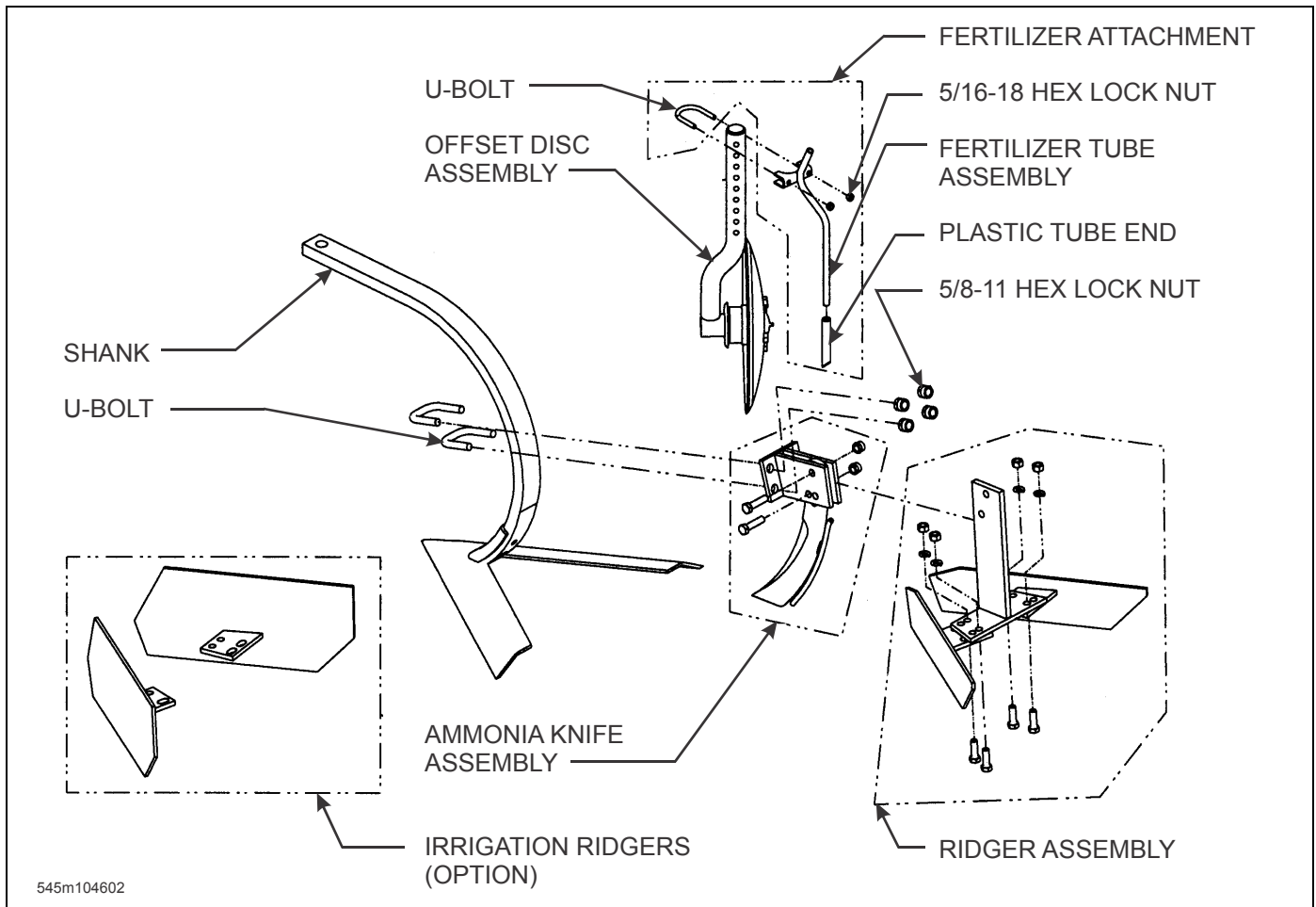

Figure 3-7: Optional Accessories Installation

Ridgers

A ridger is an optional device that can be installed on each shank.

1. Full ridgers should be installed on the inner shanks, and half ridgers should be mounted on the outer, end shanks. (Half ridgers should be inside of the tool assembly.)
2. Assemble a shank clamp (See Figure 3-7) to the rear of each shank. Secure the bracket with u-bolts and 5/8-11 hex lock nuts.

Anhydrous Ammonia Knives

1. The ammonia knives are mounted in the same manner as the ridgers. They cannot be used at the same time the ridgers are being used (See Figure 3-7.)

Fertilizer Tubes

1. The fertilizer tubes should be mounted on the disc shaft assemblies. Secure with a u-bolt and 5/16-18 hex lock nuts (See Figure 3-7.)

IMPORTANT

Be sure to raise the tubes high enough to clear the ground to prevent plugging the tubes.

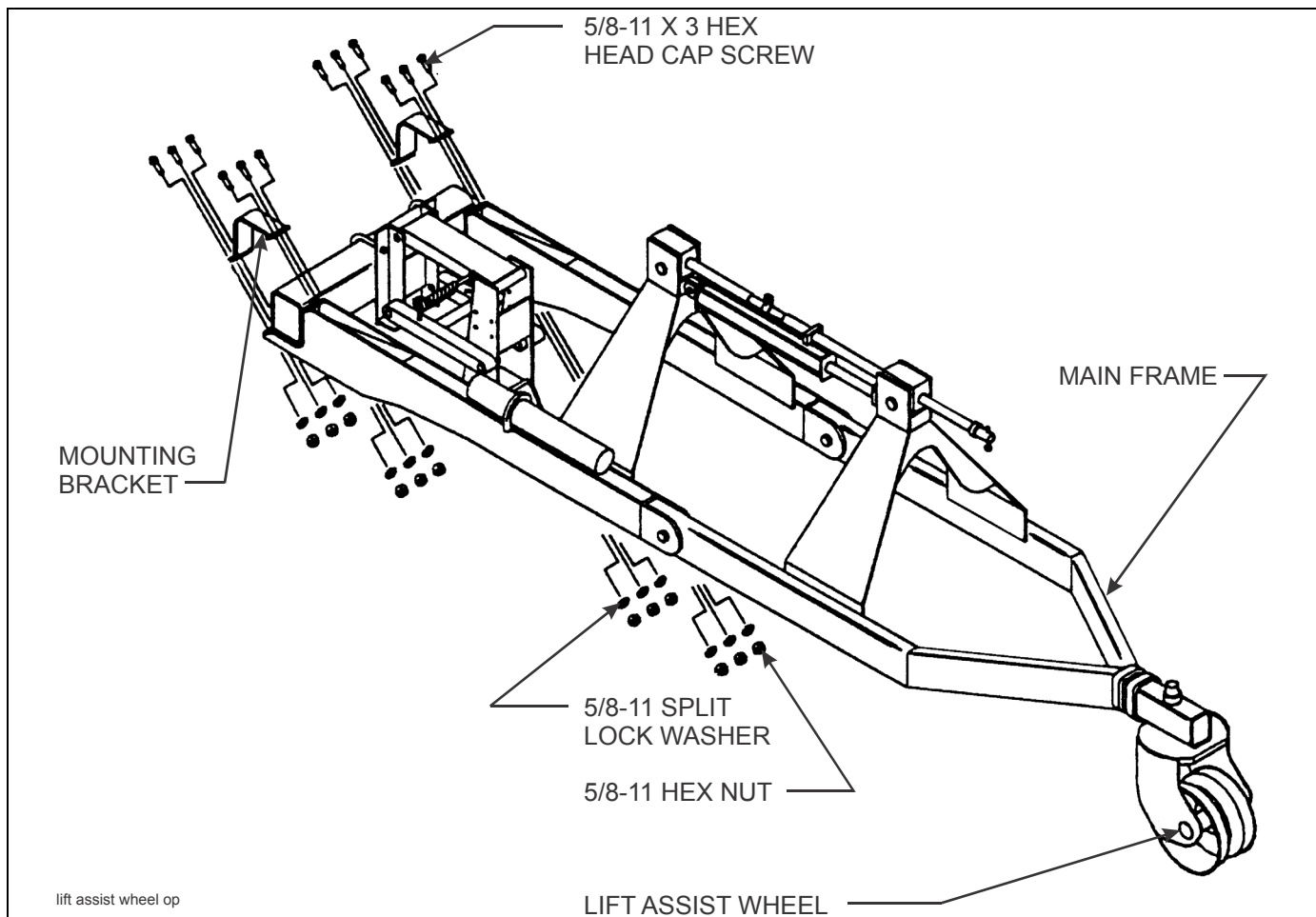

Figure 3-8: Lift Assist Wheel Installation

Lift Assist Wheel



WARNING

An escaping hydraulic oil under pressure can produce enough force to penetrate the skin, causing serious personal injury. Before applying pressure to the system, be sure all connections are tight and that lines, pipes, and hoses are not damaged before disconnecting lines, be sure to relieve all pressure. Hydraulic oil escaping from a very small hole can be almost invisible. Use a piece of cardboard or wood, not your hands, to search for suspected leaks.

1. Place the base of the lift assist wheel frame against the main frame bar, straddling (on both sides of) the center tool frame assembly. Secure the assist wheel using the mounting brackets, 5/8-11 X 3 hex head cap screws, lock washers, and hex nuts that come with the lift assist wheel (**See Figure 3-8.**)
2. Coupling hoses are to be owner-supplied. They should be long enough to allow lifting or lowering of the cultivator without stretching the hoses. Be sure to set the hoses so not to interfere with the operation of the cultivator. Once set, secure the hoses with tie wraps.



WARNING

If injured by escaping hydraulic oil, see a doctor at once. Serious infection or reaction can develop if proper medical treatment is not administered immediately.

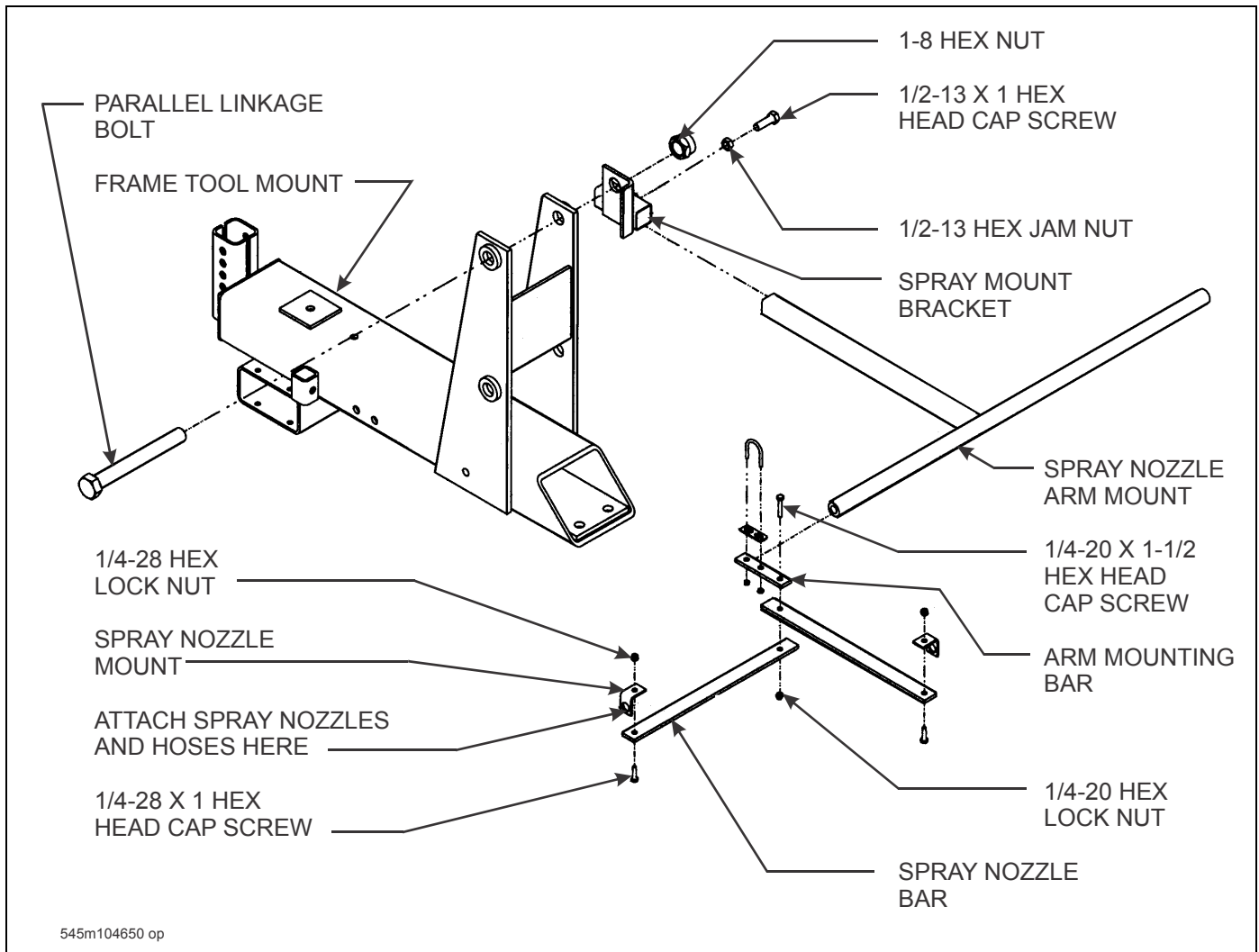

Figure 3-9: Spray Nozzle Mount Installation

Spray Nozzle Mount Attachment

The optional spray nozzle attachment adds a spray accessory to the cultivator. One spray nozzle attachment services two rows on the cultivator, so they should be attached to every other tool frame (**See Figure 3-9.**)

1. Remove the 1-8 hex nut from the rear, top, parallel linkage bolt. Install the spray mounting bracket to the parallel linkage bolt and replace the nut. Tighten it until the side plates are just snug against the bushing of the top parallel linkage.
2. Assemble the spray nozzle arm mount to the spray mount bracket and secure it with the 1/2-13 X 1 hex head cap screw and hex jam nut.
3. Assemble the spray nozzle bars to each other. Assemble the arm mounting bar with a 1/4-20 X 1-1/2 hex head cap screw, a spray nozzle arm mount, and hex lock nut. There should be two sets of these assemblies per attachment.
4. Assemble the remaining spray nozzle mounts to the extended ends of the four spray nozzle bars with 1/4-28 X 1 hex head cap screws, and hex lock nuts.
5. Assemble these spray nozzle arm assemblies to each end of the spray nozzle arm mount using a u-bolt, u-bolt bracket, and nut.

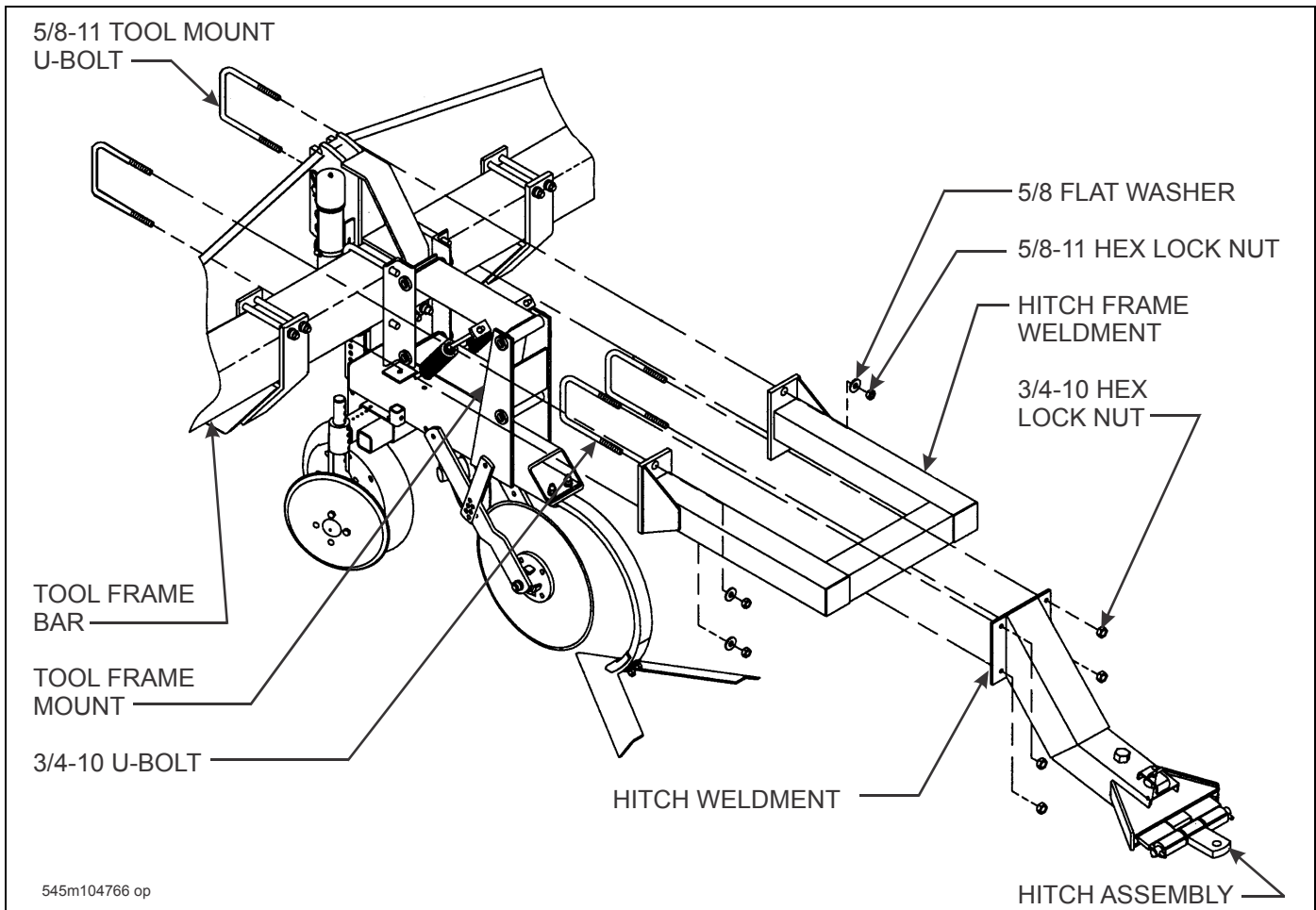

Figure 3-10: Nurse Tank Hitch Installation

Nurse Tank Hitch Assembly

IMPORTANT

See Figure 3-10 for parts names.

1. Set tool frame bar on support stands.
2. Attach the hitch frame weldment to the tool frame bar by straddling it around the center tool frame mount assembly. Use the tool mount 5/8-11 u-bolts, flat washers, and hex lock nuts to secure this assembly.
3. Assemble the hitch assembly to the hitch frame weldment (**See Figure 3-10.**)
 - a. Align the hitch assembly centered on the hitch frame weldment.
 - b. Use the 3/4-10 u-bolts and hex lock nuts to secure these weldments.

WARNING

- BEFORE OPERATING - STUDY OPERATORS MANUAL SAFETY MESSAGES AND SAFE OPERATING PROCEDURES. READ SAFETY SIGNS ON THIS MACHINE.
- TRANSPORT ON PUBLIC ROADS - OBSERVE FEDERAL, STATE AND LOCAL REGULATIONS; DISPLAY SMV EMBLEM; ATTACH PROPER STRENGTH IMPLEMENT SAFETY CHAIN; AND LIMIT MAXIMUM SPEED TO 20mph (32 km/h).
- LOWER OR BLOCK ALL ELEVATED COMPONENTS BEFORE SERVING OR LEAVING THIS MACHINE.

2-573-01006

DANGER

UNDER NO CIRCUMSTANCES SHOULD ANYONE RIDE ON THE MACHINE. FAILURE TO HEED WILL RESULT IN SERIOUS INJURY OR DEATH.

1-573-010096



DANGER

STAND CLEAR OF WINGS WHILE UNFOLDING. CHARGE HYDRAULIC FOLD CYLINDERS WITH HYDRAULIC OIL BEFORE ATTEMPTING TO FOLD OR UNFOLD WINGS.

2-573-010037



1700 May Street
Box 111
Marysville, Kansas 66506

MANUFACTURED UNDER ONE OR MORE OF THE FOLLOWING PATENTS:
US: 4361191, 4621807, 4928774, 5082064
CANADA: 539499

1-573-010373

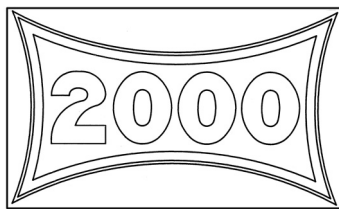
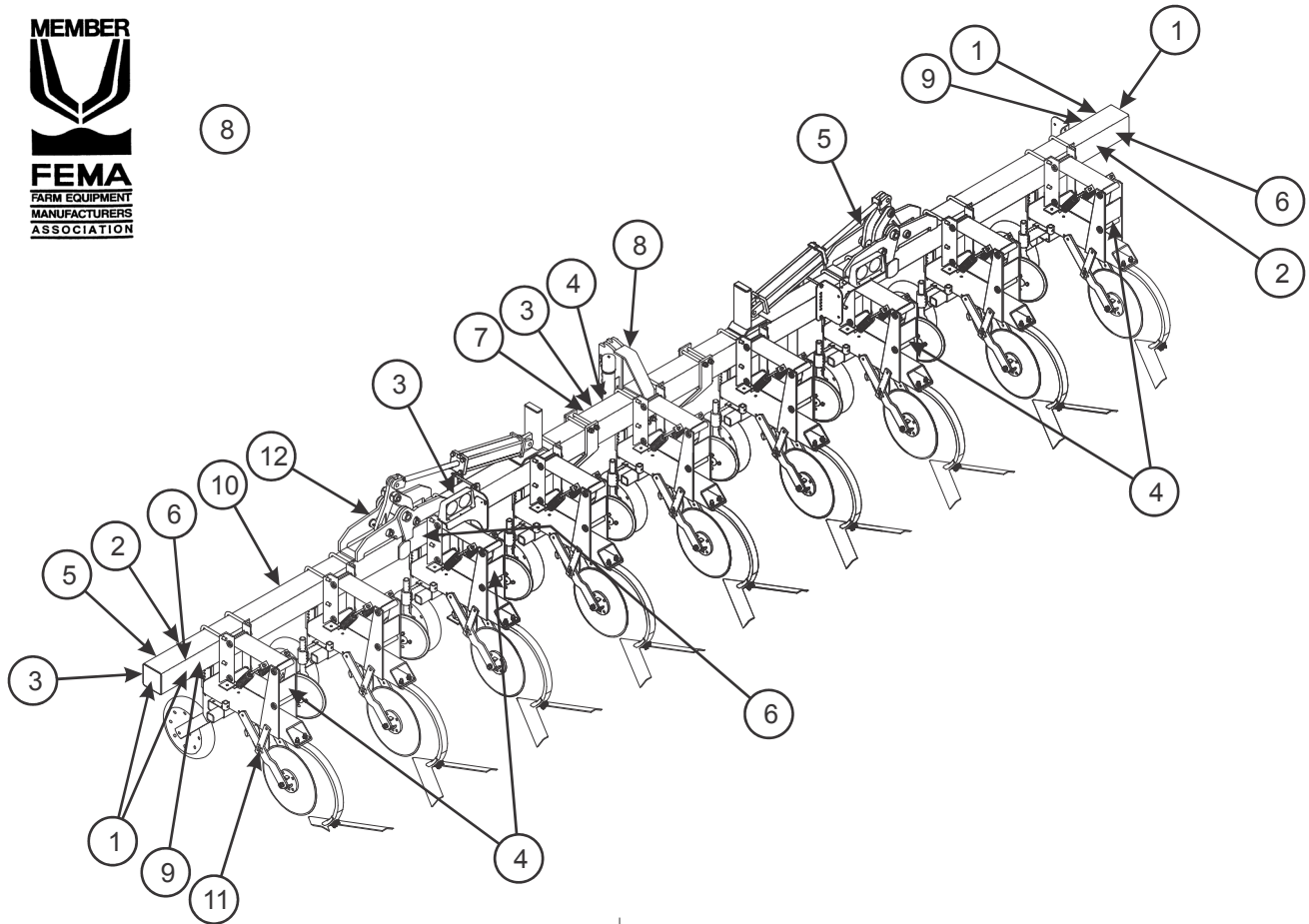

2000B row crop decals

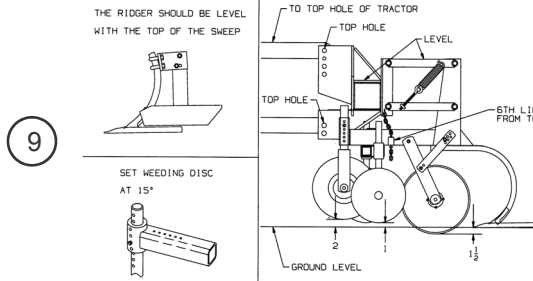

Figure 3-11: Decal Installation

Decal Placement

Decals are extremely important for naming purposes and for alerting others to the presence of the machine.

PLACE ALL DECALS on the cultivator as shown in

Figure 3-11. Center them as nearly as possible between the top and bottom on the frame bar. Sometimes, shank spacing may position a tool frame too near the end of the frame bar to place a reflective tape square exactly as shown. Then place the square between the U-bolts on the tool frame as near the proper location as possible. A red reflective square is attached to the rear of the left- and right-hand end tool frames at the factory. If any decals become unreadable, or are destroyed during use, get replacement decals from your Landoll dealer as soon as possible, and replace them on the machine.

Notes:

Operation and Maintenance



DANGER

Never allow anyone to ride on the 2000 Series Row Crop Cultivator at any time. Allowing a person to ride on the machine can inflict serious personal injury or death to that person.



DANGER

Never stand under or near the hydraulic folding wings during folding or unfolding operations. The wings may drop very quickly resulting in serious injury or death to anyone under or near the cultivator wings.



DANGER

Coulter blades are extremely sharp. Exercise extreme care when working on or near disc blades. Do not allow discs to roll over or fall onto any bodily part. Do not allow wrenches to slip when working near disc blades. Never push wrenches toward disc blades. Do not climb over machine above disc blades. Failure to stay clear of disc blade edges can cause serious personal injury or death.



DANGER

When transporting the unit, place cylinder lockouts in the transport lock position after fully extending the cylinders. Insert the lockout pins to secure the cylinder lockouts. Failure to lockout the cylinders can cause the unit to settle during transport, which can result in serious injury or death and cause damage to the equipment.



DANGER

All hydraulically elevated equipment must have cylinder lockouts installed or be lowered to the ground, when servicing or when equipment is idle. Failure to take preventive measures against accidental lowering can result in serious personal injury.



CAUTION

When transporting farm implements on public roads, it is the responsibility of the operator to abide by state and local laws concerning wide loads, speed, safety emblems and safety lighting equipment. Drive at safe speeds. Particularly when rounding corners, crossing rough ground or driving on hillsides, to prevent tipping the tractor.

Tractor Preparation

The 2000 Series Row Crop Cultivator may be used on tractors equipped with category II or III three-point hitches with quick couplers. Before attaching the cultivator, prepare the tractor as follows:

The rear tractor tires should be inflated equally and ballast added according to the tractor operator's manual.

1. Install front-end weights as needed on tractor to maintain stability (**See Section 2, "Standard Specifications" for cultivator weight**). Lower the draft arms, by means of the draft arm control lever until the draft arm hitch sockets align with the lower hitch brackets on the cultivator. Place the draft arm control lever in the least sensitive position. Remove stabilizer bars or sway blocks during hookup and operation. Replace after hookup for transporting.

Cultivator Preparation

1. Before operating the cultivator, inspect it to be sure it is in good operating condition.
2. Replace badly worn or missing parts and any rough or worn wheel or disc bearings.
3. While the machine is new, bolt tightness should be checked after a few hours of operation. Tighten any loose nuts or bolts.

Attaching To Three Point Hitch

1. Carefully back the tractor into place.
2. Attach the cultivator to the tractor draft arms. Be sure the hitch pins and sleeves are installed as shown in **Figure 4-1**.
3. Reinstall the stabilizer bars or sway blocks before transporting.

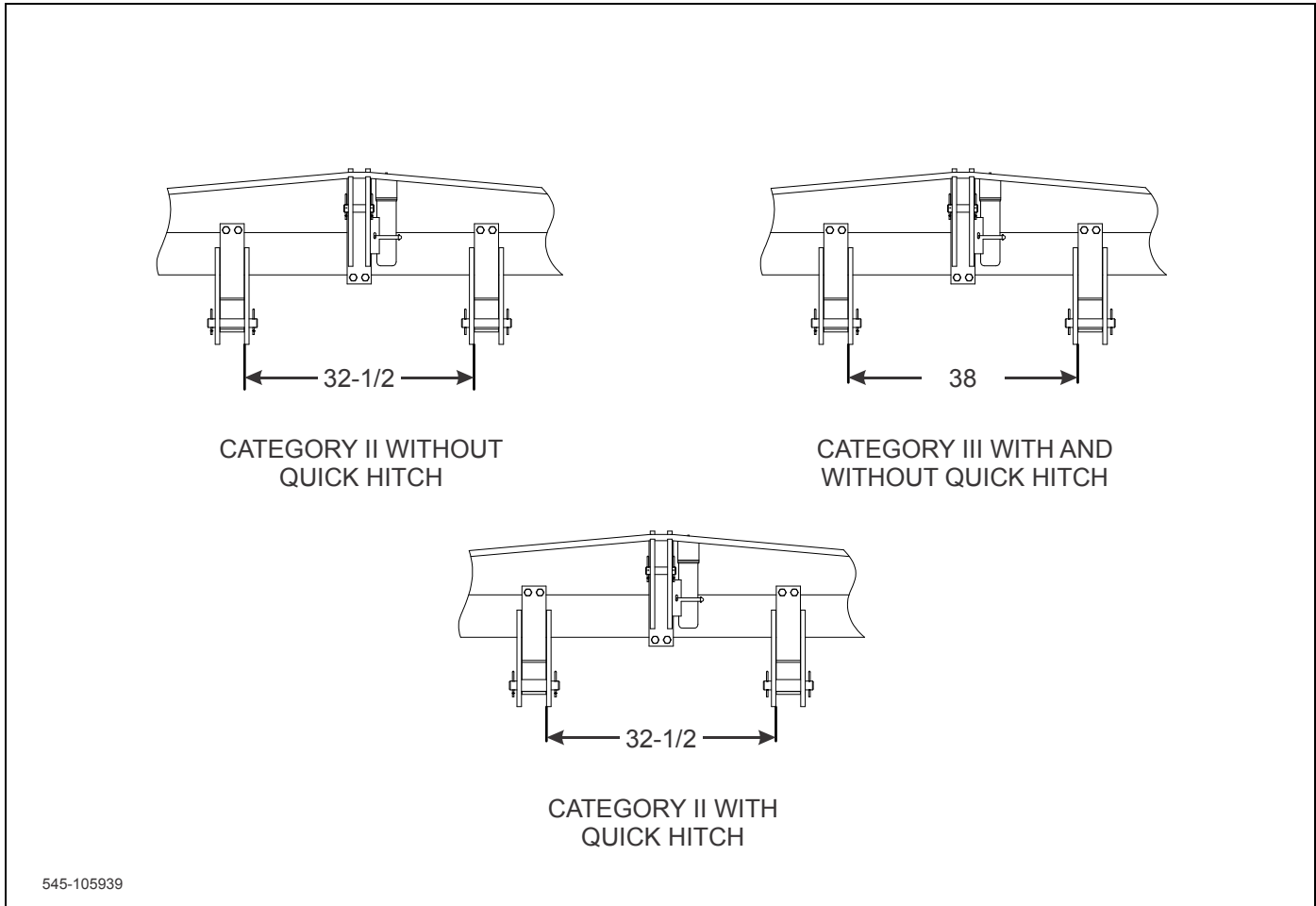

Figure 4-1: Examples of Hitch Setups

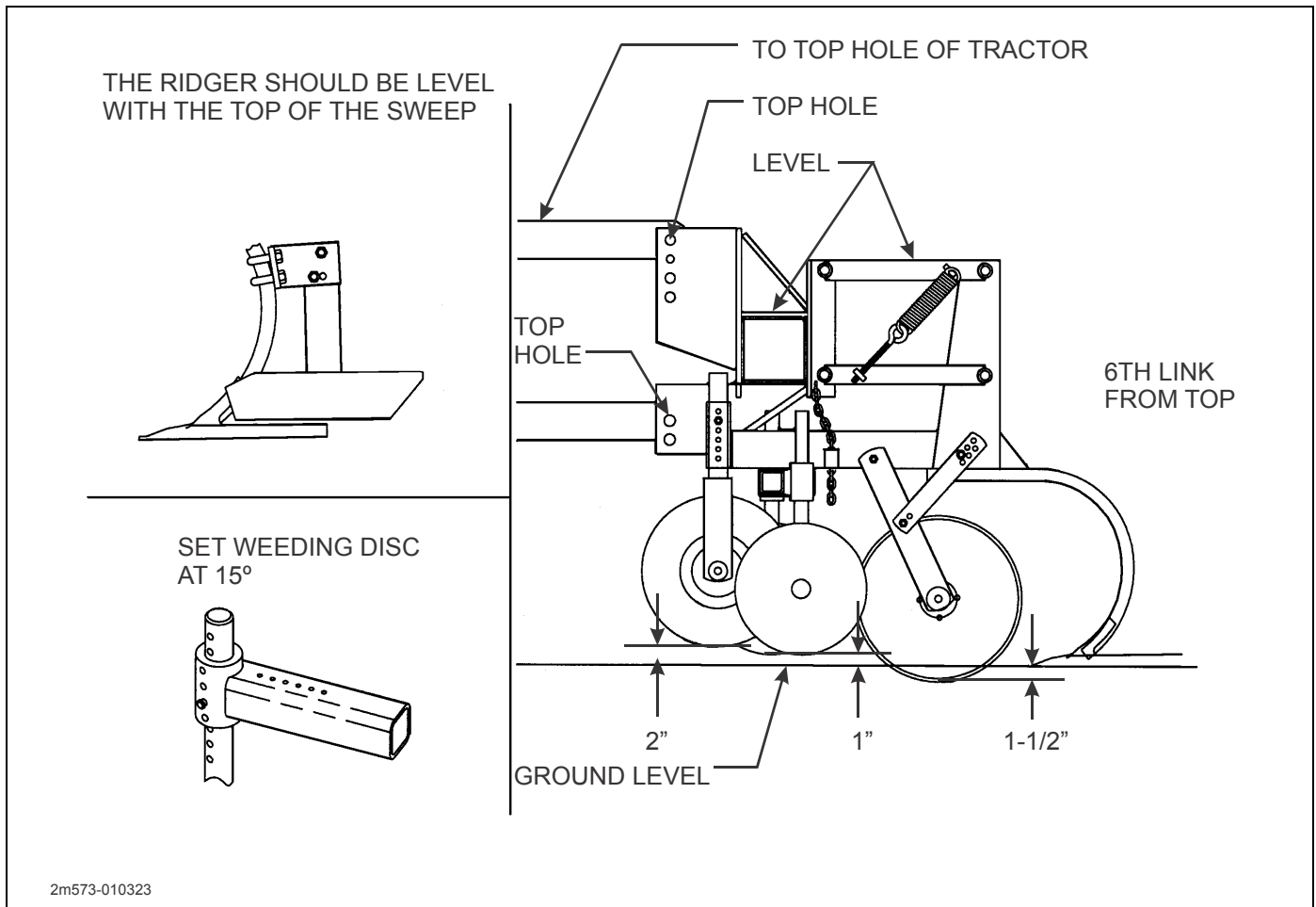

Figure 4-2: Recommended Settings for Initial Setup

Initial Setup

1. Set the tractor and cultivator on a cement or other hard, level surface, and check that the top adjustment link is greased and easy to operate.
2. Lower the cultivator until the sweeps contact the surface. The gauge wheels should now be about two inches above the surface and the tool frames should be level with the surface. If not, adjust the top adjusting link until the tool frames are level, and set the gauge wheel adjustment (**See Figure 3-3**) to two inches above the surface.
3. Raise the cultivator just off the surface. Check for side to side levelness of the main frame bar with the tractor rear axle. If necessary, level the frame bar with the tractor's draft arm vertical height adjuster.
4. Adjust weeding discs to 1" above sweep at a 15° angle (**See Figure 4-2.**)
5. Adjust coulter to 1-1/2" below the sweep.
6. Adjustments for particular field conditions are described in the following section.

Field Operation

1. Remove the stabilizer bars or sway blocks from the drawbar assembly on the tractor.
2. Pull the cultivator a few feet at the approximate desired depth and speed you intend to maintain during use. Adjust the cultivator properly according to the procedures described in **“Gauge Wheel Adjustment” on page 4-5, “Coulter Adjustment” on page 4-5, “Disc Adjustment” on page 4-7, “Disc Bearing Maintenance” on page 4-7, “Tool Frame” on page 4-8, “Ridgers and Knives” on page 4-8, “Shields” on page 4-9, and “Lift Assist Wheel” on page 4-9.**
3. **Always lift the cultivator completely out of the ground before turning or backing** to prevent shank, disk, or coulter damage, or damage to their respective mounting brackets.
4. **Reduce speed at field ends**, raise the cultivator out of the ground, and if needed, assist turning by using the wheel brakes. Do not lower the cultivator into the ground during turning operations.
5. After a few hours of operation, check all bolts for tightness. Tighten any loose bolts.
6. **When folding wings on wing fold models always be sure that the wings are out of the ground before folding. When unfolding the wings, leave the hydraulic lever in the “EXTEND” position for a few seconds to lock the wings in operational position.**
7. **READ WARNINGS ON THIS PAGE.**
8. The Nitrogen accumulator (**See Figure 4-9**) on the Lift Wheel Assist provides protection for the hitch mast and tractor three-point top link, when fully mounted. It also serves as a cushion to shock loads when the raised implement is maneuvered. Oil is transferred from the cylinder to the Nitrogen accumulator while moving over uneven ground to relieve excess stress. After moving back to level ground, pressure build-up within the accumulator forces oil back into the cylinder. This provides lift assist, which is preset by the adjustment screw. **See “Lift Assist Wheel” on page 4-9 BEFORE** adjusting this screw.



WARNING

An escaping hydraulic oil under pressure can produce enough force to penetrate the skin, causing serious personal injury. Before applying pressure to the system, be sure all connections are tight and that lines, pipes, and hoses are not damaged. Before disconnecting lines, be sure to relieve all pressure. Hydraulic oil escaping from a very small hole can be almost invisible. Use a piece of cardboard or wood, not your hands, to search for suspected leaks.

If injured by escaping hydraulic oil, see a doctor at once. Serious infection or reaction can develop if proper medical treatment is not administered immediately.



WARNING

To avoid personal injury, stay clear of lift assist wheel and implement during operation. Perform any adjustments or service on implement when it is in lowered position.

Gauge Wheel Adjustment

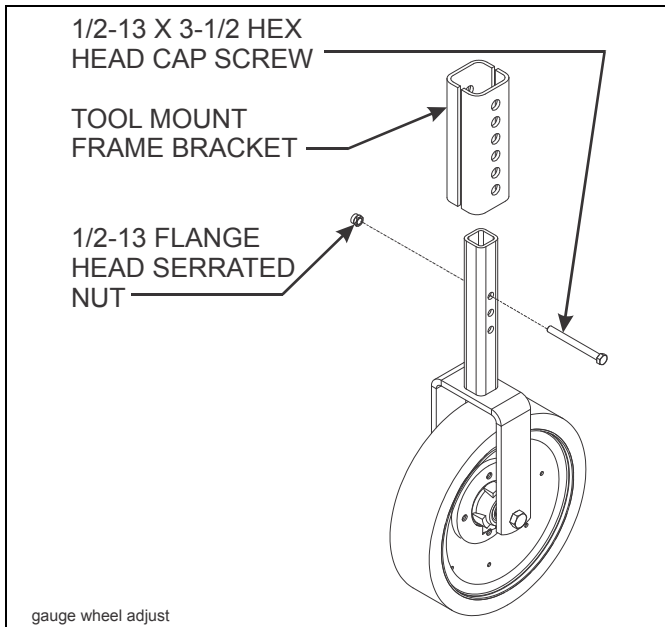

Figure 4-3: Gauge Wheel Adjustment

1. For stability, the gauge wheels must always apply slight pressure against the soil. Adjust the gauge wheels by raising or lowering, as needed, to reach proper depth. To reach proper depth (**See Figure 4-3**):
 - a. remove the screw in the gauge wheel shaft
 - b. make the proper adjustment
 - c. reinstall the screw
 - d. tighten the screw and lock nut until the gauge wheel is securely clamped into position.
2. There are several points to consider when setting the gauge wheel depth:
 - a. When the cultivator is in the ground and the depth is set, the tool frames should tip slightly forward. This is done by raising or lowering the gauge wheels and adjusting the tractor top adjustment link.
 - b. On very soft or loamy soil, it may be necessary to set the gauge wheels directly behind the tractor tires a little different than the others. This allows their respective sweeps to maintain the same depth as the other sweeps.
 - c. The depth should be sufficient to move the desired amount of soil and to get the sweep into good, solid soil during high trash situations.

Coulter Adjustment

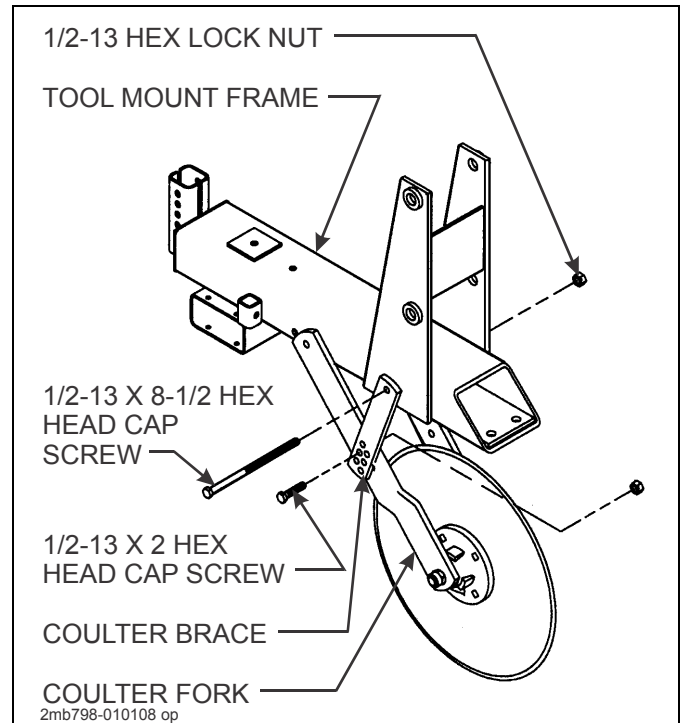

Figure 4-4: Coulter Adjustment

Initial setting for a coulter is at least one inch below the working depth of the sweeps. Generally, the harder the soil, the less pressure used on the coulters. To adjust coulters (**See Figure 4-4**):

1. Remove the 1/2-13 X 8-1/2 hex head cap screw that goes through the coulter brace and the tool frame mount.
2. Raise or lower the entire coulter fork assembly until the proper height is reached. Use the lower two holes in the coulter brace for 18" coulters (standard). Use the next two holes (above) for the 20" inch coulter option (**See Figure 3-5**).
3. Reinstall the 1/2-13 X 8-1/2 hex head cap screw and the hex lock nut through the coulter braces and tool frame mount. Extra holes are also provided on the lower coulter braces for more adjustment.

IMPORTANT

The coulters directly behind the tractor tires may need to be set slightly different than the other coulters.

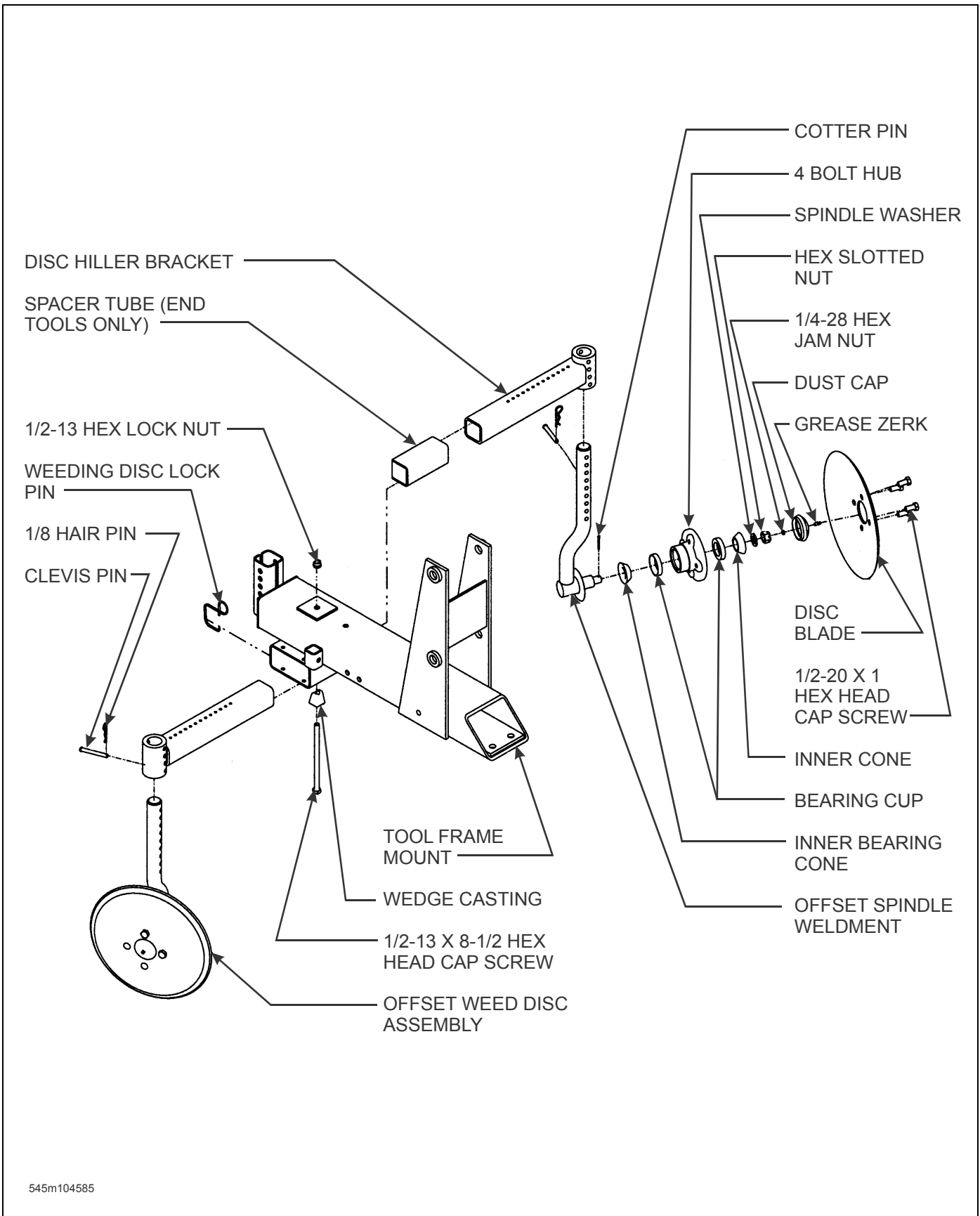

545m104585

Figure 4-5: Disc Adjustment

Disc Adjustment

Adjust the disc to the proper depth and pitch to create the desired weeding effect. Discs working at different settings from each other tend to make the machine fight itself. Also, discs working too deeply into the soil tend to throw up excess dirt, resulting in root pruning, which causes the sweeps to plug. To adjust the discs (**See Figure 4-5**):

1. **DEPTH** - Remove the 1/8 hair pin and clevis pin from the offset weed disc spindle weldment, and set the disc assembly to the desired depth. Standard depth for optimum weeding is 1" to 1-1/2" below the surface. Reinstall the clevis and hair pins.
2. **WIDTH** - Loosen the wedge casting in the bottom of the tool frame. Remove the weeding disc lock pins from the tool frames and disc brackets. Move the disc assembly in or out as needed, replace the weeding disc lock pins, and retighten the wedge casting. Hammer upward on the head of the 1/2-13 X 8-1/2 hex head cap screw to set the wedge tightly and replace hex lock nut.

IMPORTANT

Retighten the wedge casting cap screw several times during the first hour of the machines operation.

3. **ANGLE** - Remove the clevis and hair pins from the disc hiller brackets. Adjust the right and left disc assembly to the same angle. Four angle settings are allowed at: 11°, 15°, 19°, and 23° (15° nominal). Replace the pins.

Disc Bearing Maintenance

Check all roller bearings occasionally for excess end play. To adjust or replace the roller bearings:

1. Place the cultivator frame on blocks or stands just high enough to lift the tire clear off the ground and stable enough to prevent tipping.
2. Remove the disc/hub assembly (**See Figure 4-5**.)
3. Clean and inspect the bearings and hub cavity. Replace any worn or defective parts.
4. Repack the roller bearings using a high quality grease.
5. Reassemble the hub assembly, bearing, and seal.
6. Tighten the bearings while rotating the hub until there is a slight resistance to hub rotation. Then, back the nut off one notch until the hub rotates freely without end play.
7. Install a new cotter pin and the dust cap.
8. Fill the hub cavity through the grease zerk with high-quality grease until the grease is forced past the seal. This will not damage the seal.
9. Wheel bearing maintenance should be done at the start of every season, and more often when used in extremely wet soil conditions.

Tool Frame

1. The length of up and down movement for the tool frame is controlled by the limit chain (See Figure 4-6) on the left side of the tool frame. If a different distance of movement is required, change the limit chain one link at a time until the desired amount of movement is met.

IMPORTANT

A longer limit chain setting will result in less ground clearance when the machine is lifted out of the ground.

Ridgers and Knives

1. Adjust the ridgers or anhydrous ammonia knives (See Figure 4-7) by loosening the clamp bracket on the shank, and slide the ridger or knife to the desired depth. Loosen the ridger bracket bolts and slide the ridgers in or out to the desired width. Retighten the bracket bolts.

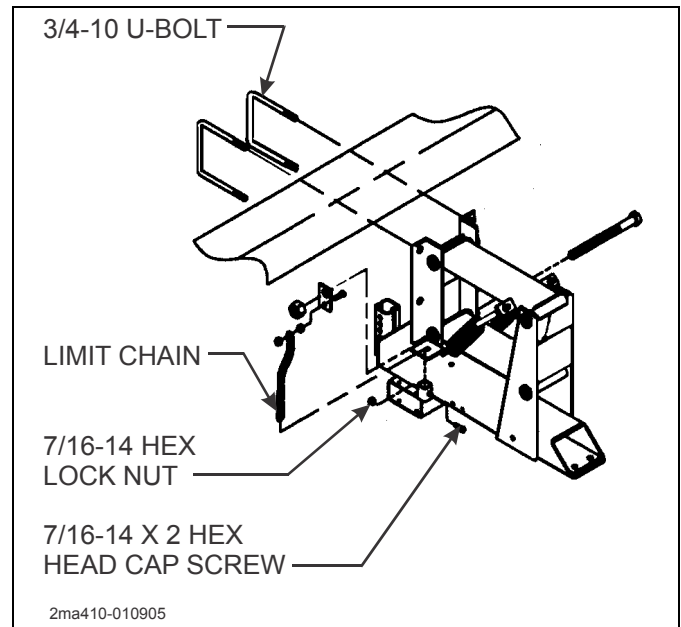

Figure 4-6: Limit Chain Adjustment

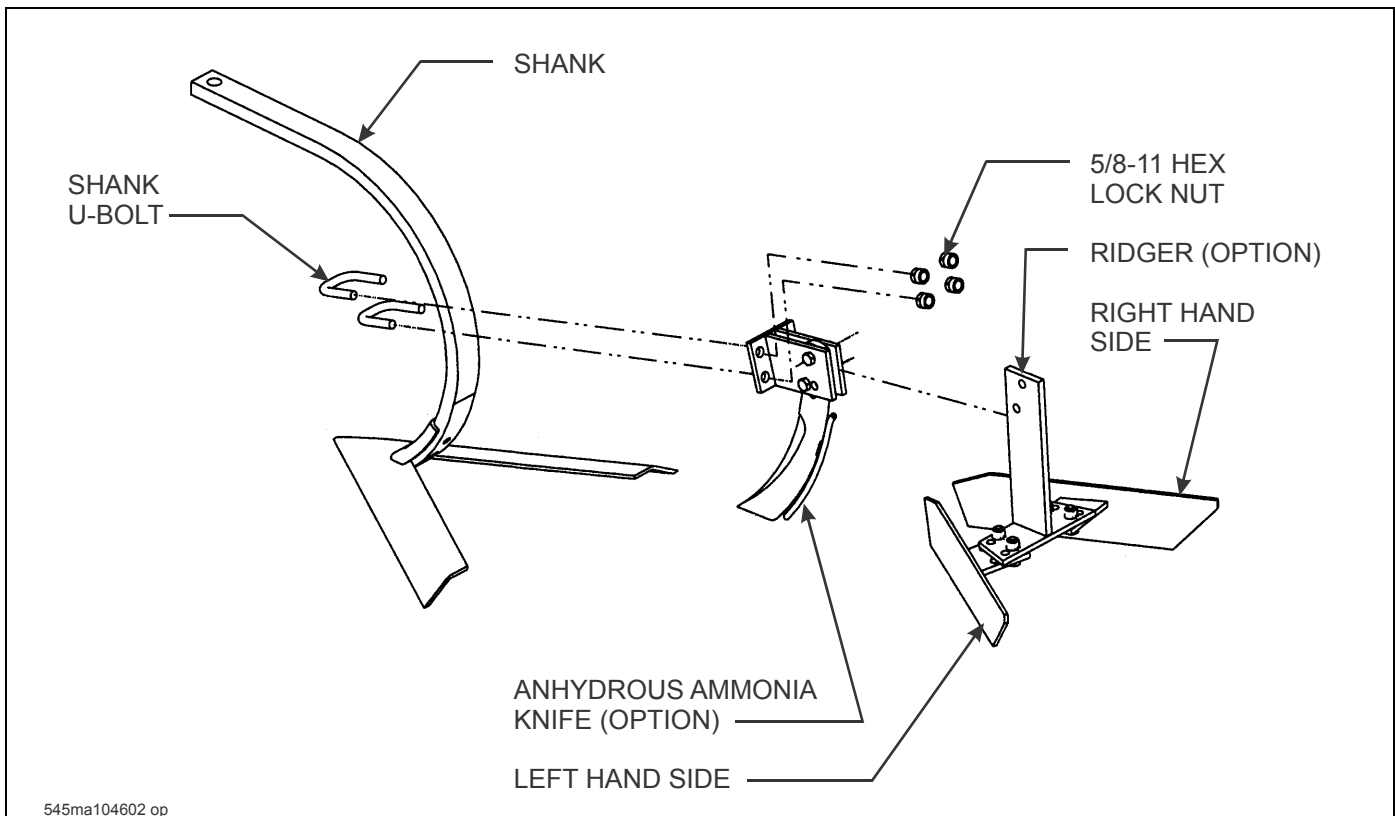

Figure 4-7: Ridger and Knife Adjustment

Shields

Adjust the shields by moving the shield adjustment chain up or down one link at a time until the desired height is reached (See Figure 4-8.) The shield width can be adjusted by loosening the adjustment screws and sliding the shields in or out to the desired width. Tighten the adjustment screws.

Lift Assist Wheel

Adjust the optional lift assist wheel so that when the machine is in use, the lift assist wheel is lifted clear of the ground. Raise or lower the lift assist wheel, as needed, with the adjustment screw on top of the lift assist wheel frame (See Figure 4-9.)

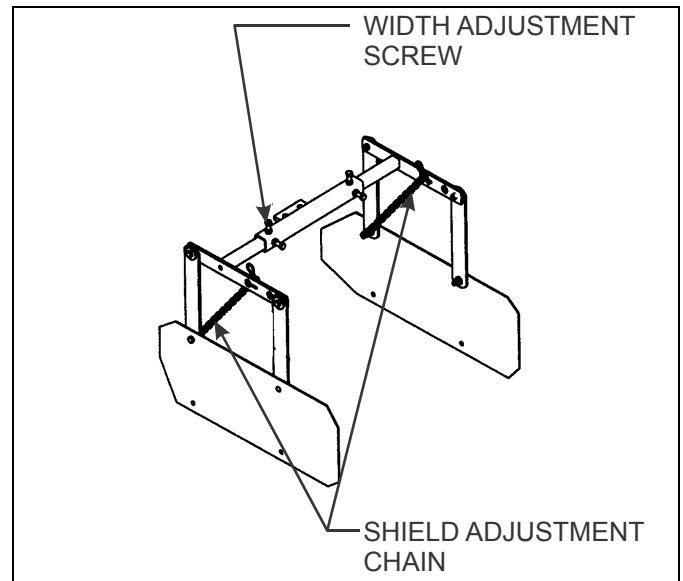

Figure 4-8: Shield Adjustment

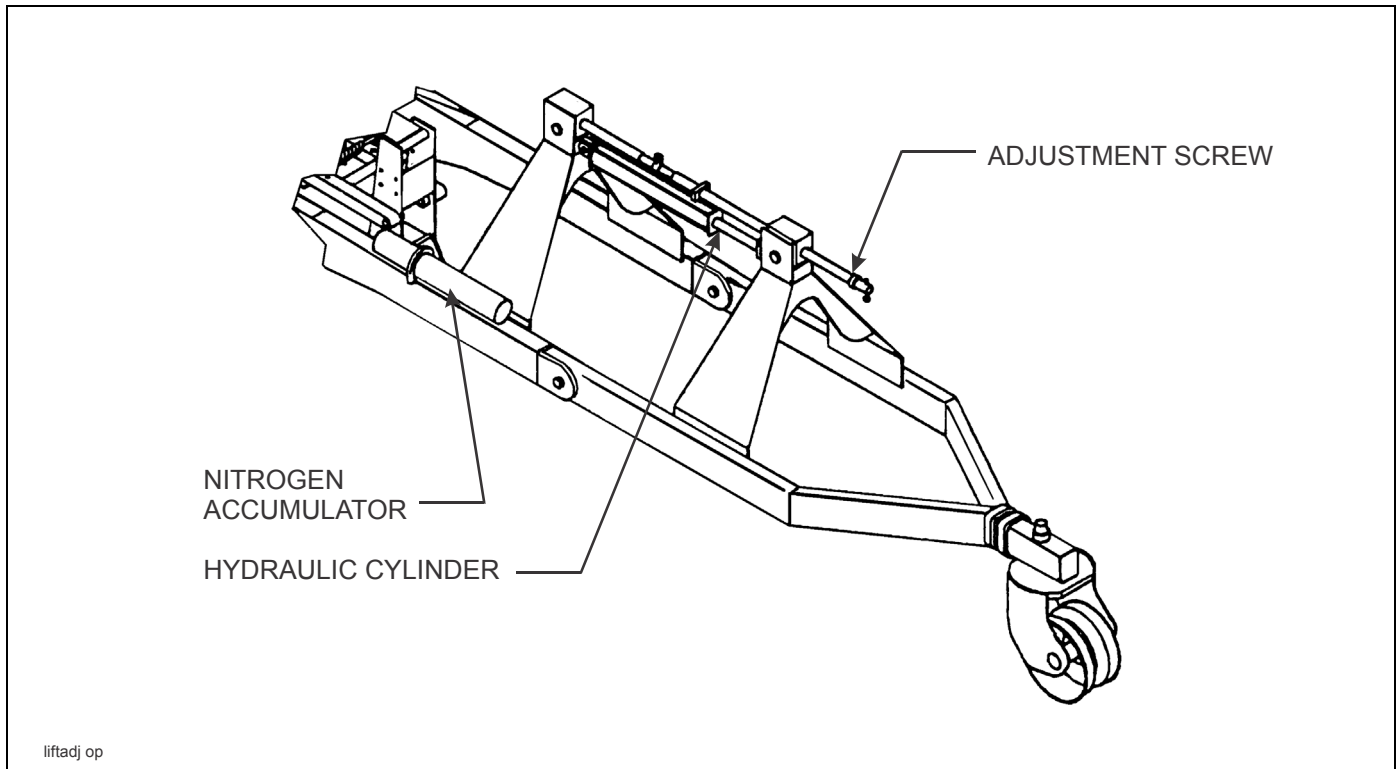

Figure 4-9: Lift Assist Wheel Adjustment

liftadj op

Tool Hold Down Springs

The hold down springs are on either side of the parallel linkage on the tool frames and are factory adjusted for most normal conditions. Tightening the springs increases the ground tool pressure. Too much pressure will shorten the life of the ground tools.

Hydraulic Maintenance

1. Check the tractor hydraulic fluid level per tractor owners manual and after any leakage. Check fluid level with the cylinders in the retracted position.
2. If a cylinder leaks, disassemble the parts to determine the cause of the leak. Any time a cylinder is opened up, or whenever any seal replacement is necessary, it is advisable to clean all parts and replace all seals. Seal kits are available from your Landoll dealer.
3. Check all hydraulic hoses weekly, Look for binding or cracking. Replace all worn or defective parts immediately.

Lubrication

See Figure 4-10 for lubrications points and recommended maintenance schedule.

1. The coulters hub bearings, and disc hiller bearings should be lubricated with a high grade multi-purpose grease twice a day or every five hours. They should be filled till the grease is forced past the seals. This will not damage the seals.
2. The wing fold pins (if applicable) should be greased daily with a high grade multi-purpose grease.

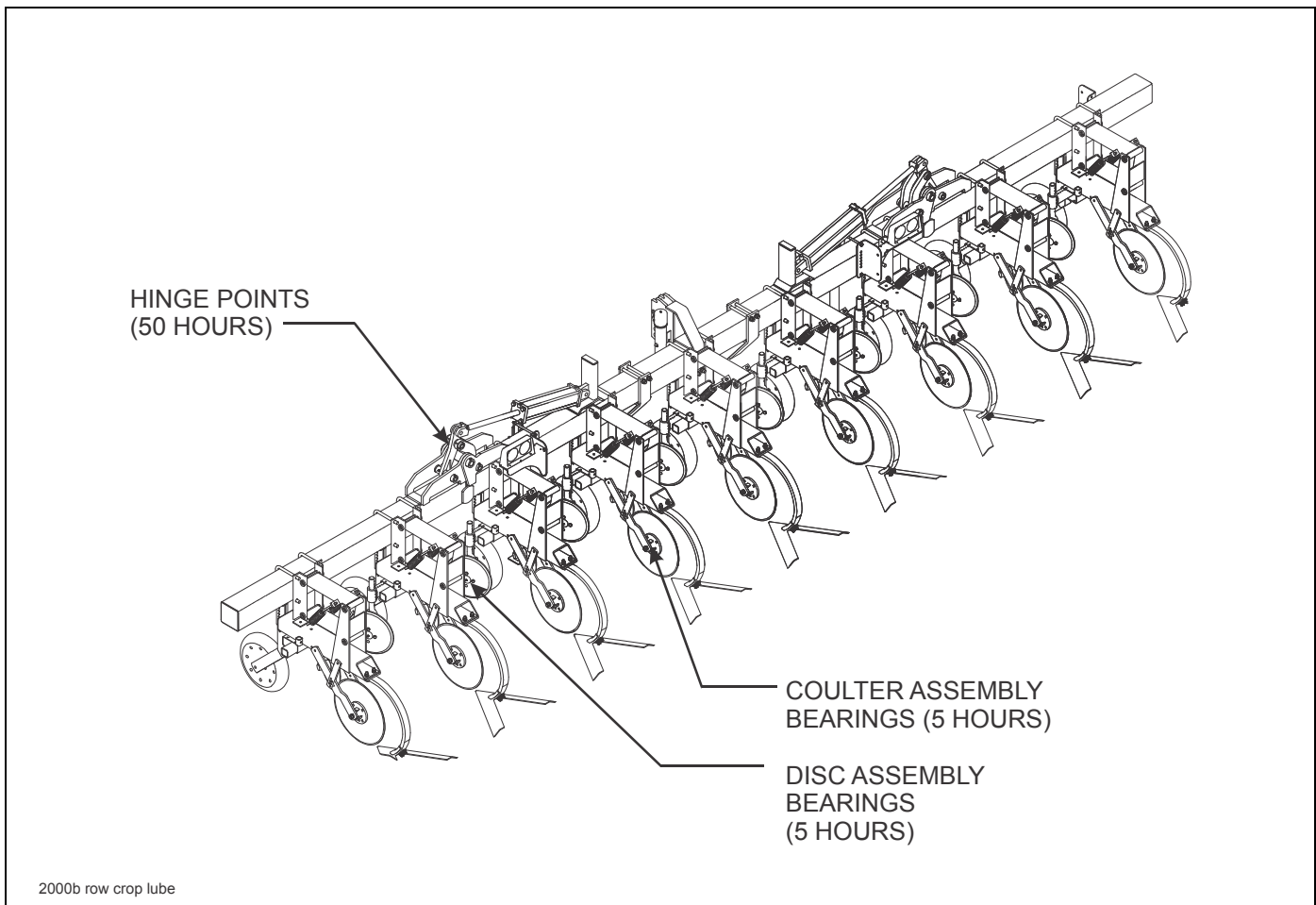

Figure 4-10: Lubrication Schedule

Storage

The service life of the cultivator will be extended by the following proper off-season storage practices:

1. Completely clean the unit and inspect the machine for worn or defective parts. Replace defective and worn parts, as needed, to avoid delays the following season.
2. Repaint all areas where the original paint film is worn off.
3. Grease all exposed metal surfaces of shanks, points, and coulters.
4. Lubricate as suggested in **“Lubrication” on page 4-10.**
5. Store the unit in a shed, or under a tarpaulin, to protect it from the weather. The ground tools and tires should rest on a board or other device to keep them out of the soil.
6. Fully extend the hydraulic gauge wheel cylinders, and place the cylinder lockouts in the transport lock position over the cylinder rods. Secure the lockouts with the lockout pins.
7. Always place the swivel jack on the interior mount before setting the machine in motion.

Troubleshooting Guide

The Troubleshooting Guide, shown below, is included to help you quickly locate problems that can happen using your 2000 Series Row Crop Cultivator. Follow all safety precautions stated in the previous sections when making any adjustments to your machine.

PROBLEM	PROBABLE CAUSE	SOLUTION
SWEEPS NOT PENETRATING THE SOIL	Tool bar, parallel linkage, and sweeps are not set properly.	Adjust top link in 1/2 turn increments until tool bar, parallel linkage, and sweeps are running level in working depth (See “Initial Setup” on page 4-3.)
	Severe conditions	Add washers on top bolt between sweep and shank (See “Disc Installation” on page 3-4.)
	Gauge wheels are not set properly.	Gauge wheels must be set approximately 2" above sweep (See “Gauge Wheel Adjustment” on page 4-5.)
	The weeding discs are holding the sweep out of the ground.	Set the weeding discs approximately 1" above the sweeps.
	Coulter not set properly.	Raise the coulter (See “Coulter Adjustment” on page 4-5.)
	The ridgers are on upside-down	Reassemble ridgers properly (See “Ridgers and Knives” on page 4-8.)
WEEDING DISCS ARE PRUNING CROPS	Crops are too big	Remove weeding discs (See “Disc Adjustment” on page 4-7.)
	Weeding discs are set at too great an angle	Reduce the angle.
GAUGE WHEELS ARE NOT CONTACTING THE SURFACE	The gauge wheel adjustment is not set correctly	Adjust gauge wheels properly (See “Gauge Wheel Adjustment” on page 4-5.)
	Coulter not set properly.	Raise the coulter (See “Coulter Adjustment” on page 4-5.)
	The weeding discs are holding the sweep out of the ground.	Set the weeding discs approximately 1" above the sweeps.
	The top link is too long, causing the sweep to ride on its heels.	
SLABBING	Weeding discs not set properly.	Adjust the weeding discs to break up the soil in front of the sweep (See “Disc Adjustment” on page 4-7.)
TRASH CATCHING ON COULTER BLADE	Coulter is set to run too deep.	Raise the coulter. Run it shallower (See “Coulter Adjustment” on page 4-5.)
	Weeding disc is throwing too much dirt and trash.	Reduce angle and/or run it shallower.

Notes:



Intertek

Equipment from Landoll Corporation is built to exacting standards ensured by ISO 9001 registration at all Landoll manufacturing facilities.

Model 2000 Series
Row Crop Cultivator
Operator's Manual

Re-Order Part Number F-140-0512

LANDOLL CORPORATION

1900 North Street

Marysville, Kansas 66508

(785) 562-5381

800-428-5655 ~ WWW.LANDOLL.COM



Copyright 2010. Landoll Corporation

"All rights reserved, including the right to reproduce this material or portions thereof in any form"