

Series 2840

CUDA[®]
Kärcher Group

Operator's Manual

Automatic Parts Washer
Front-Load

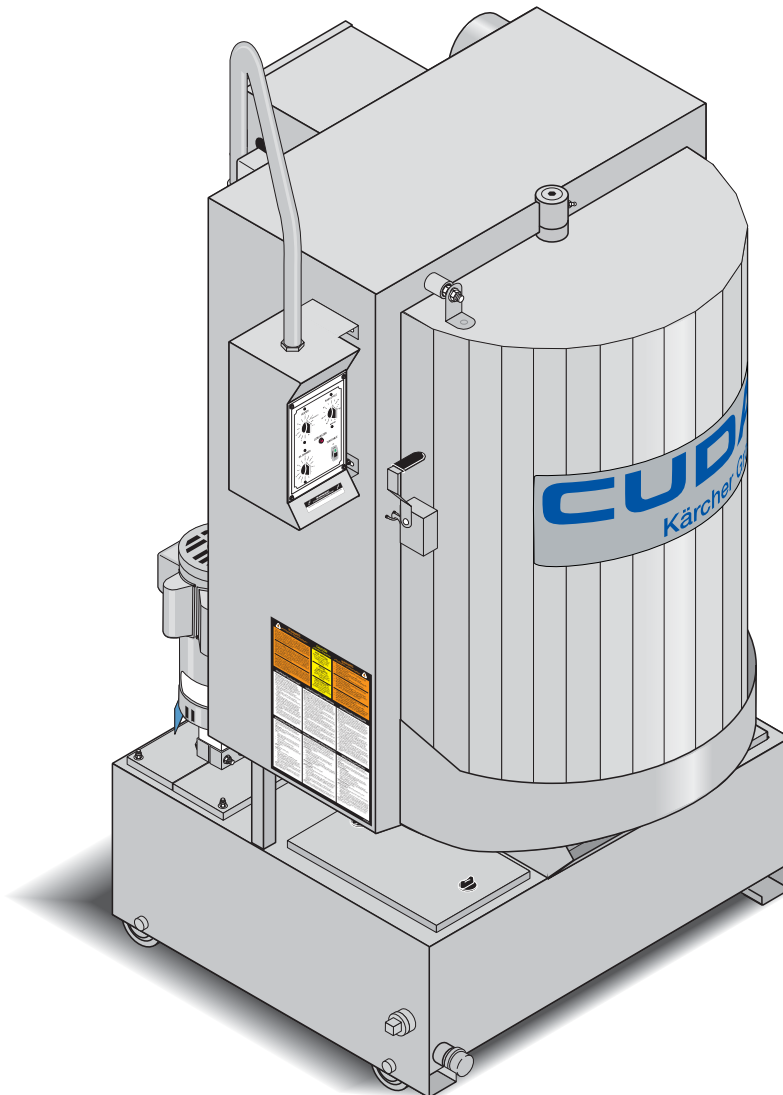

MODELS:	1.043-395.0
	1.043-416.0
	1.043-417.0
	1.043-418.0
	1.043-419.0
	1.043-420.0
	1.043-492.0
	1.043-493.0
	1.043-494.0
	1.043-496.0
	1.043-497.0
	1.043-498.0



WARNING:

This product and accessories may contain a chemical known to the State of California to cause cancer and birth defects or other reproductive harm.

For more information about this regulation: www.P65Warnings.ca.gov

For the Cuda Dealer nearest you, consult our web page at www.CudaUSA.com



Machine Data Label

Model: _____

Date of Purchase: _____

Serial Number: _____

Dealer: _____

Address: _____

Phone Number: _____

Sales Representative: _____

Machine Data Label2
Table of Contents3
How To Use This Manual4

Safety

Introduction & Safety Information5
 General Safety Information6

Operations

Component Identification - Front View8
 Component Identification - Rear View9
 Component Identification - Front - Options10

Installation11

Before You Begin11
 Step 1: Make Electrical Connections11
 Step 2: Configure The 24-hour, 7-day Timers11
 Step 3: Connect A Compressed-Air Line And Accessories11
 Step 4: Connect A Water Line12
 Step 5: Fill The Machine With Water And Add Detergent12

Operation14

Main Operating Components14
 Control Panel14
 Heater Control14
 Wash Cycle Control14
 Turntable Switch14
 Low Water Indicator14
 24-hour, 7-day Timers14
 Thermostat14
 Door Safety Switch15
 Adjusting the Safety Switch15
 Debris Screen15
 Air Flow Valve (Optional)15
 Detail Sump16
 Power Brush (Optional)16
 Detail Brush and Flow Regulator16
 Adjusting the Flow of Cleaning Solution16
 Oil Skimmer17
 Water Level17
 Automatic Water Fill (Optional)17
 Low Water Shut-off17
 Filtration System (Optional)18
 Sump Sweep System (Optional)19
 Detergents And Additives19
 Preparing The Machine For Use19
 Washing Parts20
 Using the Oil Skimmer System20
 Shutting Down The Machine21

Maintenance

Maintaining The Machine22

Daily Maintenance22
 Weekly Maintenance22
 Monthly Maintenance22
 Semi-Annual Maintenance22
 Cleaning and Aligning the Spray Nozzles23
 Cleaning the Filters25

Repairing The Machine26

Heating Elements26
 Thermostat26
 Turntable Motor27
 Timers and Switches on the Control Panel28
 Oil Skimmer Motor28
 Required Tools and Equipment28

Troubleshooting30

Troubleshooting The Electrical System30
 Troubleshooting a Single Phase Panel30
 Troubleshooting a Three Phase Panel31
 Testing Individual Components32

Parts

Cuda 2840 Front38
 Cuda 2840 Rear42
 Spray Arm46
 TT Motor48
 Side Control Panel50
 Electrical Panel - 208V 1PH52
 Electrical Panel - 230V 1PH54
 Electrical Panel - 208V 3PH56
 Electrical Panel - 230V 3PH58
 Electrical Panel - 460V 3PH60
 Electrical Panel - 575V 3PH62
 Oil Skimmer64
 Door Latch66

How To Use This Manual

This manual contains the following sections:

- How to Use This Manual
- Safety
- Operations
- Maintenance
- Parts List

The HOW TO USE THIS MANUAL section will tell you how to find important information for ordering correct repair parts.

Parts may be ordered from authorized dealers. When placing an order for parts, the machine model and machine serial number are important. Refer to the MACHINE DATA box which is filled out during the installation of your machine. The MACHINE DATA box is located on the inside of the front cover of this manual.

Model: _____
Date of Purchase: _____
Serial Number: _____
Dealer: _____
Address: _____
Phone Number: _____
Sales Representative: _____

The model and serial number of your machine is located on the back of the machine.

The SAFETY section contains important information regarding hazardous or unsafe practices of the machine. Levels of hazards are identified that could result in product damage, personal injury, or severe injury resulting in death.

The OPERATIONS section is to familiarize the operator with the operation and function of the machine.

The MAINTENANCE section contains preventive maintenance to keep the machine and its components in good working condition. They are listed in this general order:

- Maintaining The Machine
- Daily Maintenance
- Weekly Maintenance
- Monthly Maintenance
- Semi-Annual Maintenance
- Cleaning and Aligning the Spray Nozzles
- Cleaning the Filters
- Repairing The Machine
- Heating Elements
- Thermostat
- Turntable Motor
- Timers and Switches on the Control Panel
- Oil Skimmer Motor
- Required Tools and Equipment
- Troubleshooting
- Troubleshooting The Electrical System
- Troubleshooting a Single Phase Panel
- Troubleshooting a Three Phase Panel
- Testing Individual Components

The PARTS LIST section contains assembled parts illustrations and corresponding parts list. The parts lists include a number of columns of information:

- **REF** – column refers to the reference number on the parts illustration.
- **PART NO.** – column lists the part number for the part.
- **QTY** – column lists the quantity of the part used in that area of the machine.
- **DESCRIPTION** – column is a brief description of the part.
- **NOTES** – column for information not noted by the other columns.

NOTE: If a service or option kit is installed on your machine, be sure to keep the KIT INSTRUCTIONS which came with the kit. It contains replacement parts numbers needed for ordering future parts.

NOTE: The manual part number is located on the lower right corner of the front cover.

Introduction & Safety Information

This manual covers the operation and maintenance of your automatic parts washer. All information in this manual is based on the latest product information available at the time of printing.

We reserve the right to make changes at any time without incurring any obligation.

Owner/User Responsibility:

The owner and/or user must have an understanding of the manufacturer's operating instructions and warnings before using this machine. Warning information should be emphasized and understood. If the operator is not fluent in English, the manufacturer's instructions and warnings shall be read to and discussed with the operator in the operator's native language by the purchaser/owner, making sure that the operator comprehends its contents.

Owner and/or user must study and maintain for future reference the manufacturers' instructions.

Save these Instructions

This manual should be considered a permanent part of the machine and should remain with it if machine is resold.

When ordering parts, please specify model and serial number. Use only identical replacement parts.

This machine is to be used only by trained operators.

General Safety Information

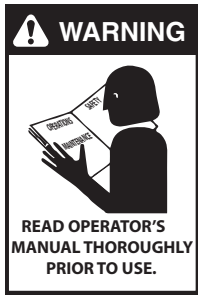

WARNING: To reduce the risk of injury, read operating instructions carefully before using.

AVERTISSEMENT: Pour réduire le risque de blessures, lire attentivement les instructions de fonctionnement avant l'utilisation.

1. Read the owner's manual thoroughly. Failure to follow instructions could cause a malfunction of the parts washer and result in death, serious bodily injury and/or property damage.



WARNING: This is a heated parts cleaner. Use only nonflammable, noncombustible, water-based cleaning compounds in this machine. Do not fill or contaminate with any flammable or combustible material such as gasoline, alcohol, mineral spirits, etc. Drain parts to be cleaned of any combustible or flammable

material before placing inside cabinet. Failure to observe this warning will create an extremely hazardous condition.

AVERTISSEMENT: Ceci est un nettoyant pour les pièces chauffées. Utiliser uniquement des produits de nettoyage à base d'eau, ininflammable et non combustible dans cette. Ne pas remplir ou contaminer avec une substance inflammable ou combustible comme de l'essence, de l'alcool, de l'essence minérale, etc. Drainer les pièces à nettoyer de toute substance combustible ou inflammable avant de les placer à l'intérieur de l'armoire. Le non-respect de cet avertissement créera une condition extrêmement dangereuse.



DANGER: Keep water away from electric wiring or fatal electric shock may result.

DANGER: Garder le jet d'eau à l'écart de tout câblage électrique ou des chocs électriques mortels pourraient survenir.

2. All installations must comply with local codes. Contact your

electrician, plumber, utility company or the selling dealer for specific details.

Install the machine in compliance with the National Electric Code. Connect to a properly sized lockable disconnect and ground machine using the grounding stud inside the main electrical panel.

3. Do not locate this machine in the vicinity of any flammable vapor, liquids or solids.
4. To protect the operator from electrical shock, the machine must be electrically grounded. It is the responsibility of the owner to connect this machine to a grounded receptacle of proper voltage and amperage ratings. Do not touch machine with wet hands or while standing in water. Always disconnect the power before servicing.
5. Do not touch machine with wet hands or while standing in water. Always disconnect the power before servicing.
6. Never make adjustments on machine while it is in operation except those prescribed in this manual.



WARNING: Use extreme caution when opening the door of this parts washer. Hot water/detergent vapors will be emitted. Stand Back! Hot cleaning solution could cause serious injury.

AVERTISSEMENT: Faire preuve d'extrême prudence au moment d'ouvrir le volet de cette partie de la laveuse. De l'eau chaude/des vapeurs de détergent seront émises. Se tenir à l'écart! Une solution de nettoyage chaude haute pression pourrait causer des blessures graves.

7. Before servicing the machine, refer to all safety data sheets (SDS's) on the material identified in the waste stream. You must comply with all warnings and wear all protective clothing stated on the SDS.

WARNING: Slips and falls from wet surfaces could cause serious injury.

AVERTISSEMENT: Les chutes et les trébuchements causés par des surfaces humides pourraient causer des blessures graves.

8. Use caution when lifting items in and out of parts basket to prevent back injuries.

9. When the machine is working, do not cover or place in a closed space where ventilation is insufficient. Avoid installing machines in small confined areas.
10. In cold climates, this parts washer will freeze if not in operation and must be located in a heated enclosure.
11. Maintain an unobstructed work area around the machine and keep the floor free of water, oil, grease or other foreign substances.
12. Always ensure that your parts washer is clean. Pump and heating elements could be damaged by continued build-up of sludge.
13. Check water level daily. Never allow water level to drop below pump inlet screen or heating elements.
14. Before discarding the spent washing solution, check with your local EPA or sewer district for disposal regulations.
15. Do not operate the machine with the lid or door open and do not override the safety switch.
16. After the machine stops, wait 10 seconds before opening the lid or door.

This automatic parts washer is designed to operate safely and efficiently. Before you begin to install and use the machine, please familiarize yourself with the major components.

Component Identification - Front View

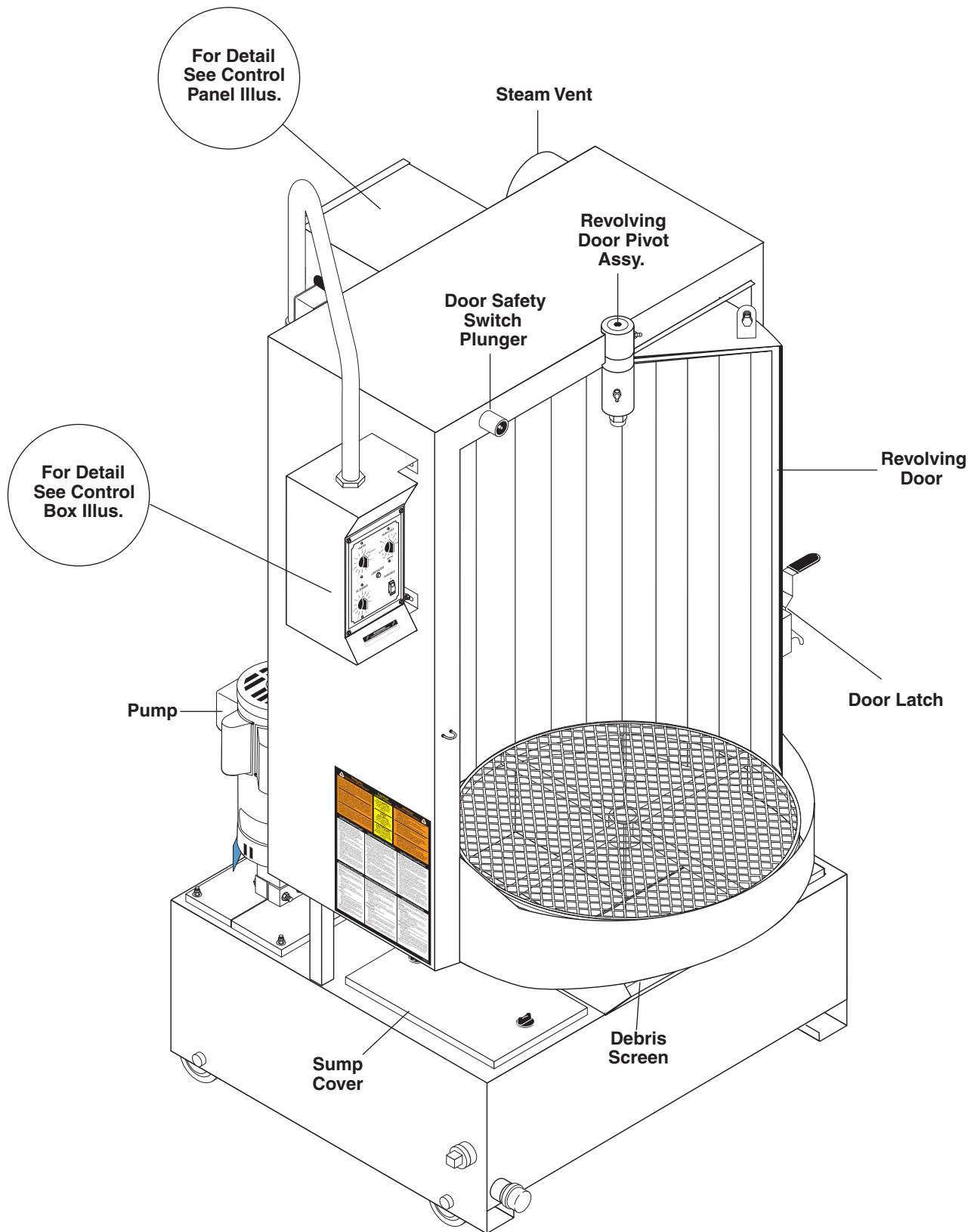

Component Identification - Rear View

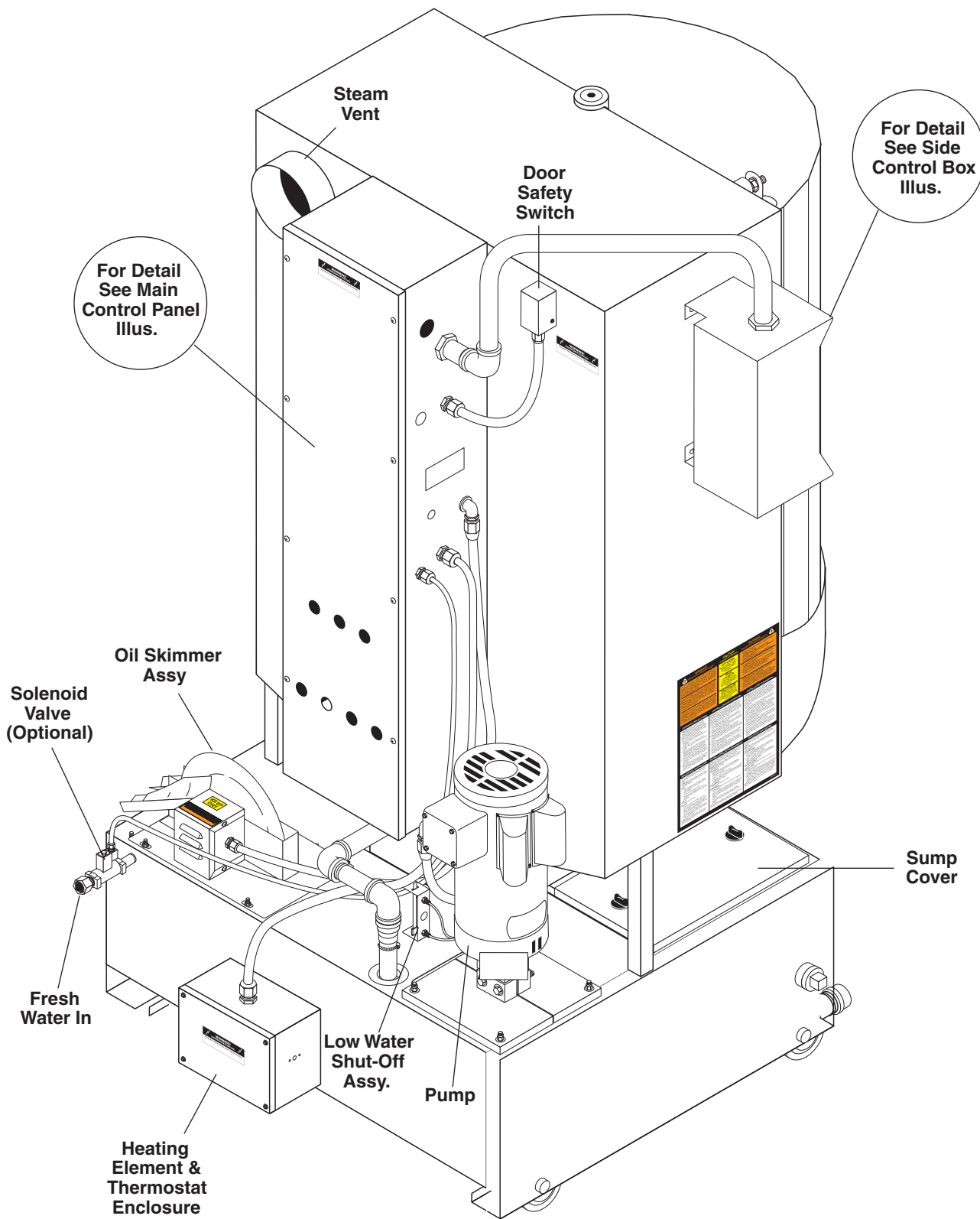

Component Identification - Front - Options

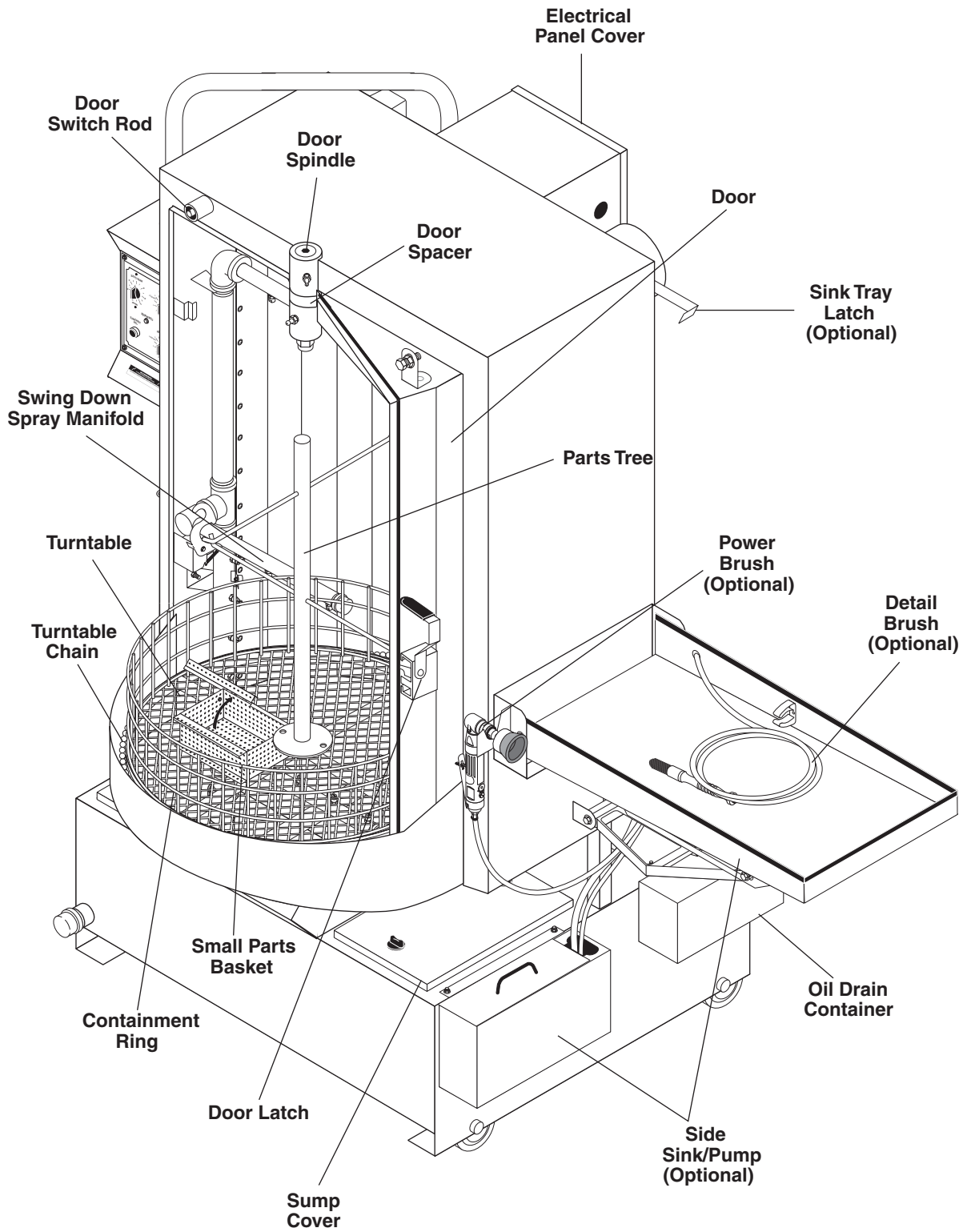

Installation

Before You Begin

To prepare to install the machine, choose an unobstructed, level site that allows convenient access for operators and maintenance personnel. Sources for water and electrical power should be located near the installation site. If your machine is equipped with the optional power brush and hand detail brush you must also run a compressed air line to the installation site.

If you have any questions regarding the installation, please contact your dealer or call a customer service representative.

When contacting customer service please refer to the machine identification tag inside the front cover of this manual for detailed machine specifications.

Step 1: Make Electrical Connections

NOTE: All electrical installation tasks must be performed by a licensed, professional electrician to ensure safe and proper operation. The installation must comply with the National Electric Code and all applicable state and local codes.

The machine can only operate on the type of electrical power indicated on the electrical specifications tag.

Read and understand the electrical specifications tag to determine the electrical power requirements before installing the machine.

Step 2: Configure The 24-hour, 7-day Timers

NOTE: This step is required for machines equipped with an optional 24-hour, 7-day heater timer or a 24-hour, 7-day heater and oil skimmer timer. If your machine does not have a 24-hour, 7-day timer, skip this step.

The optional 24-hour, 7-day heater timer controls the heating system. The optional 24-hour, 7-day heater and oil skimmer timer controls the heating system and the oil skimmer.

The parts washer requires approximately 1 to 2 hours to heat the wash solution to operating temperature, and the oil skimmer requires 10 to 15 minutes to effectively remove oil from the wash solution. Using either timer, you can schedule the heating system to turn on several hours before you begin to use the machine each day. In

addition, the optional 24-hour, 7-day heater and oil skimmer timer allows you to schedule the oil skimmer to operate while the machine sits idle.

The timer is located below the electrical panel inside the main electrical enclosure. To configure the timer, refer to the instruction label inside the timer door.

Step 3: Connect A Compressed-Air Line And Accessories

NOTE: This step is required for machines equipped with the Deluxe Kit option package. If your machine is not equipped with the Deluxe Kit option package, skip the following procedure.

1. Remove the power brush from the box, install the wire brush in the chuck, and connect the air hose.

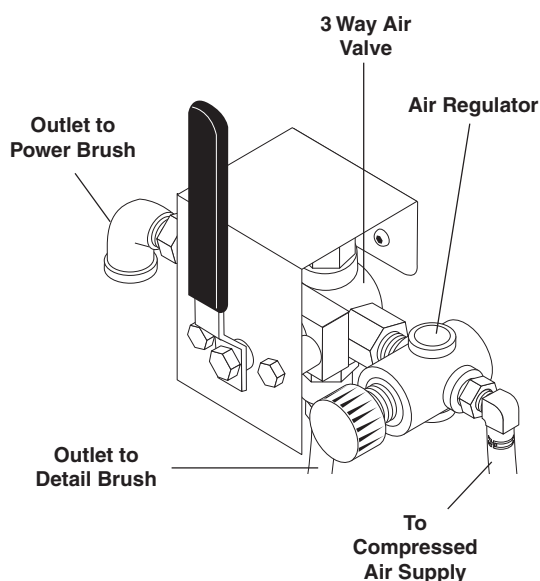

2. Familiarize yourself with the three-way air flow valve, then install a fitting to accommodate a connection to your compressed-air supply.
3. Connect the shop compressed-air line to the machine.

NOTE: To ensure proper operation and to minimize the possibility of premature component failure, make sure the compressed air is supplied at 75 to 90 psi. Manufacturer also recommends an in-line moisture trap and an in-line lubricator on the main air supply line. Refer to the documentation provided with the power brush for more information.

4. Connect the hose from the power brush to the air flow valve.
5. Hang the power brush on the bracket mounted along the right side of the machine.

Step 4: Connect A Water Line

NOTE: This step is required for machines equipped with the optional automatic water fill feature. If your machine does not have this option, skip this step.

The optional automatic water fill feature automatically maintains the correct water level in the sump. The feature requires that you connect the machine to a dedicated water supply line.

To connect the machine to a water supply line, attach a suitable burst-proof hose to the hose connection on the rear of the machine below the oil skimmer assembly, then connect the hose to a nearby water spigot.

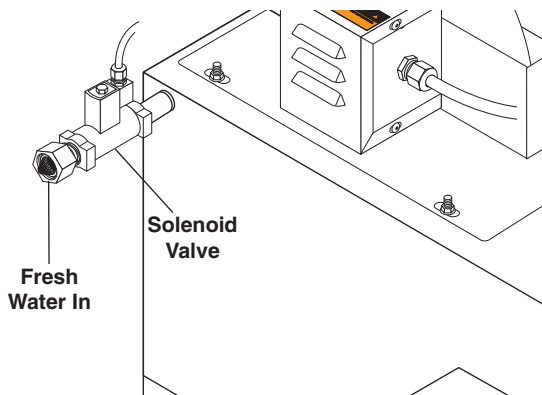

NOTE: The machine is designed for portability, and some maintenance tasks require that you move the machine. DO NOT make a permanent connection from your shop water supply to the machine.

Step 5: Fill The Machine With Water And Add Detergent

1. Fill the sump with water. If your machine is equipped with the automatic water fill feature, simply open the water inlet valve; if not, add water through the wash chamber. The sump capacity is 50 gallons.
2. When the sump is full and the low water light has gone out, shut off the water. If your machine is equipped with the automatic water fill feature the water will shut off automatically when the sump is full.

*NOTE: **Monitor the water level carefully – do not overfill the machine.** If you overfill the machine, remove excess water using a small submersible pump or a suitable container. The correct water level is two inches from the top of the sump tank when the pump is off.*

3. Turn the heater timer to the 2-hour position. The sump water will reach operating temperature (160–180°F) in approximately one to two hours.

*NOTE: To avoid waiting for the sump water to heat to operating temperature every day, manufacturer recommends a 24-hour, 7-day heater timer. With a 24-hour, 7-day timer you can set the heating system to turn on several hours before you begin to use the machine each day. For more information about 24-hour, 7-day timers refer to **24-hour, 7-day Timers**.*

4. While the sump water is heating, add the appropriate quantity of factory approved detergent to the wash chamber. We recommend mixing the detergent with warm water in a separate bucket/container and then pouring the dissolved detergent into the sump.

NOTE: Factory approved detergent is the only detergent approved for use with this automatic parts washer. It is specially formulated with rust inhibitors and anti-foaming agents to optimize performance and minimize maintenance. The use of any other detergent during the warranty period will void the warranty. In addition, using factory detergents will extend your 90 day labor warranty to 1 year.

5. Close and latch the door.
6. Turn the wash cycle timer to 2 hours for the first time, and allow the machine to complete the cycle to thoroughly dissolve the detergent into the water.

7. (If Optional Deluxe Kit Installed):

After the machine stops, remove the right sump cover and transfer approximately two gallons of wash solution into the detail sump using a small submersible pump or a suitable container.

WARNING: Hot cleaning solution could cause serious injury. Always wear rubber gloves and approved eye protection when handling hot cleaning solution.

AVERTISSEMENT: Une solution de nettoyage chaude haute pression pourrait causer des blessures graves. Toujours porter des gants en caoutchouc et une protection oculaire approuvée lors de la manutention de solution de nettoyage chaude.

8. Replace all sump covers.

When the machine stops, and after the wash water reaches operating temperature, it is ready for use.

Refer to **Section 3: Operation** for complete operating instructions.

Operation

Main Operating Components

Familiarize yourself with the main operating components before operating the machine.

Control Panel

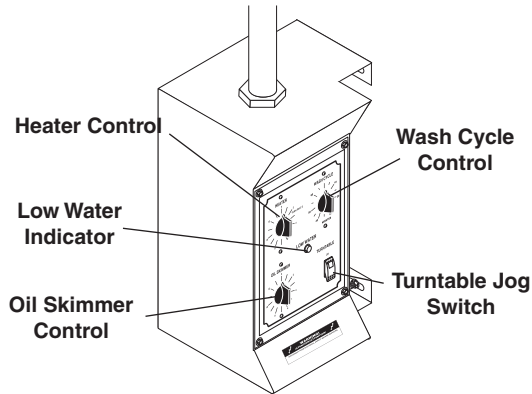

Heater Control

The heater control is a 12-hour timer switch. It controls the heating element in the sump chamber. The heating system is thermostatically set at the factory to reach a high temperature of 180°F. The temperature is adjustable using the thermostat (See **Adjusting the Thermostat**). The 3-phase units have an adjustable temperature knob - check temperature setting prior to use.

Wash Cycle Control

The wash cycle control is a 60-minute timer switch with a hold feature. When set between 1 and 60 minutes, the timer automatically shuts off the pump and turntable when the wash cycle is complete. When set to **Hold**, the pump and turntable run continuously until manually shut off.

Skimmer Control

The skimmer control is a 30-minute timer switch. It controls the automatic oil skimmer.

Turntable Switch

The turntable switch is a simple rocker switch that enables you to disconnect power to the turntable motor. Set to **ON**, the turntable rotates during the wash cycle. Set to **OFF**, the turntable does not rotate during the wash cycle. The switch is useful for washing large parts that would otherwise impede turntable rotation.

Low Water Indicator

The low water indicator light illuminates if the wash solution in the sump is low. For more information refer to **Low Water Shut-off**.

24-hour, 7-day Timers

Models 2840 and 2848 machines are available with a 24-hour, 7-day heater timer or a 24-hour, 7-day heater and oil skimmer timer. The heater timer controls the heating system. The heater and oil skimmer timer controls the heating system and the oil skimmer.

Thermostat

The thermostat is located inside the heating element and thermostat enclosure. Single phase thermostats have an adjustment screw that is accessible only from inside the enclosure. Three phase thermostats have an adjustment knob mounted on the outside of the enclosure.

The thermostat is factory-set to heat the wash solution to a maximum temperature of 180°F.

Adjusting the Thermostat

To adjust the thermostat, rotate the adjustment screw or knob clockwise to increase the temperature, or counter-clockwise to decrease the temperature.

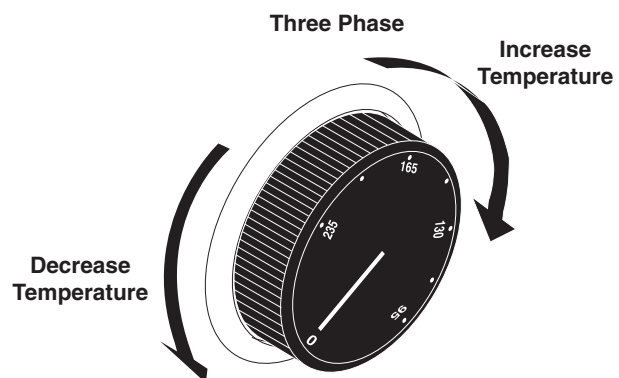
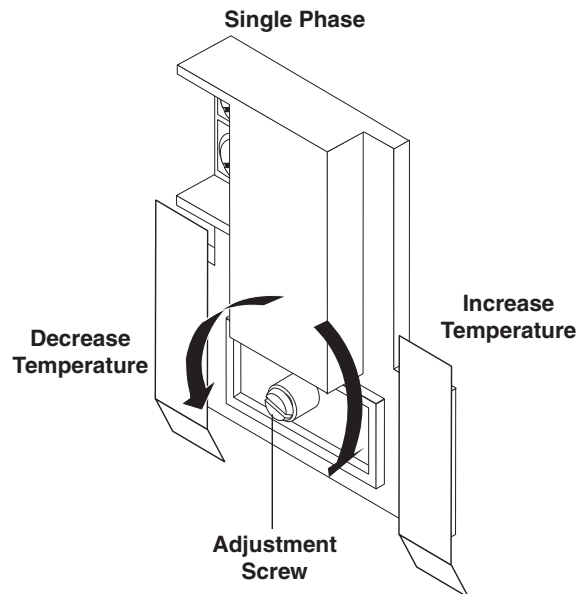

Door Safety Switch

The door closure safety switch is located on the rear of the machine, to the right of the main electrical panel. The switch is activated with a push-rod that extends through the wash chamber.

The switch disconnects power to the water pump and turntable motor if the wash chamber door is opened during a wash cycle. The water pump and turntable motor will not operate if the door is not closed and latched correctly.

Adjusting the Safety Switch

1. Disconnect power to the machine.
2. Remove the two screws from the rear of the safety switch cover, and pull the cover free of the switch assembly.
3. Loosen the adjustment nuts on both sides of the switch bracket.

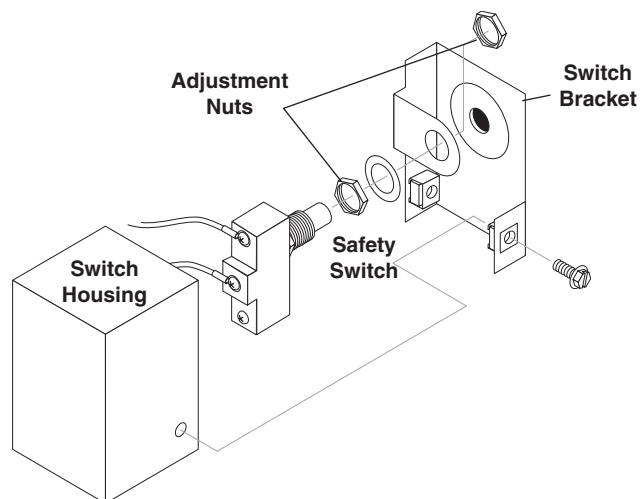

4. Adjust the switch accordingly.
5. Tighten the adjustment nuts.
6. Replace the cover.

When properly adjusted, you should hear a slight “click” as the door latch engages and compresses the door seal and the door closure safety switch.

Debris Screen

The debris screen is located just below the wash chamber, and is accessible from the front of the machine. The debris screen continuously filters debris particles from the cleaning solution to ensure blockage-free spray nozzle operation, and also provides a safeguard against small parts that might accidentally be washed through from the cleaning chamber.

The frequency at which you must clean the debris screen depends on machine usage. In general, you should clean the screen before operating the machine each day.

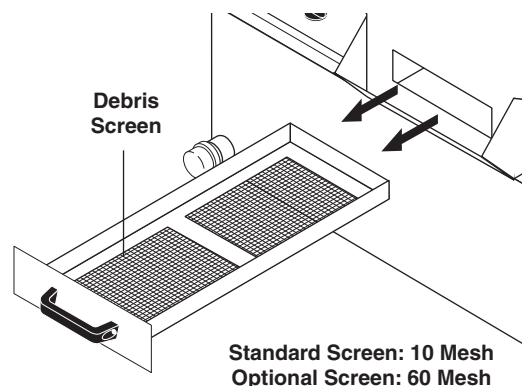

NOTE: Never operate the machine without the debris screen in place and never remove the screen while the machine is operating. The screen is specially sized to filter particles that could clog the spray nozzles or damage the water pump.

Operating the machine without the debris screen in place could cause spray nozzles to clog or the water pump to fail.

Air Flow Valve (Optional)

The air flow valve is located on the right rear corner of the machine. It is a three-way ball valve that controls the flow of compressed air to the power brush and the hand detail brush.

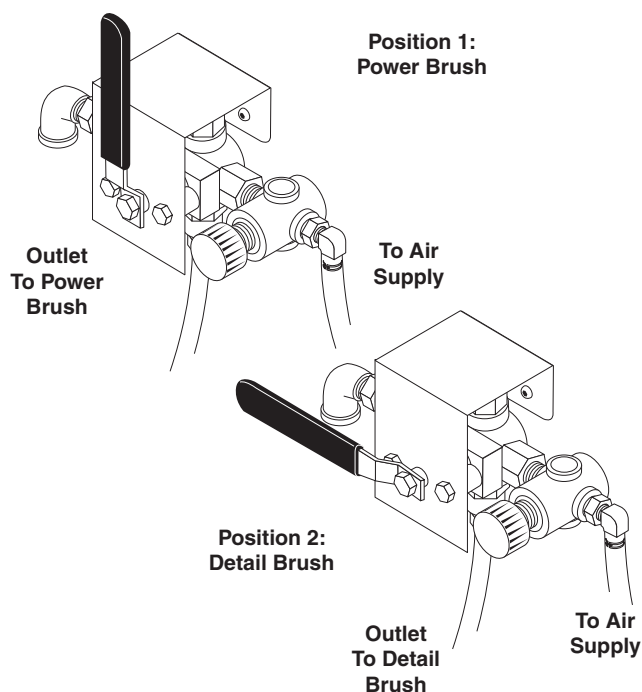

Detail Tray and Sump Assembly (Optional)

Detail Tray

The detail tray is located on the right side of the machine. The tray folds down to provide a convenient work area for using the power brush and hand detail brush. The weight capacity of the detail tray is 75 pounds.

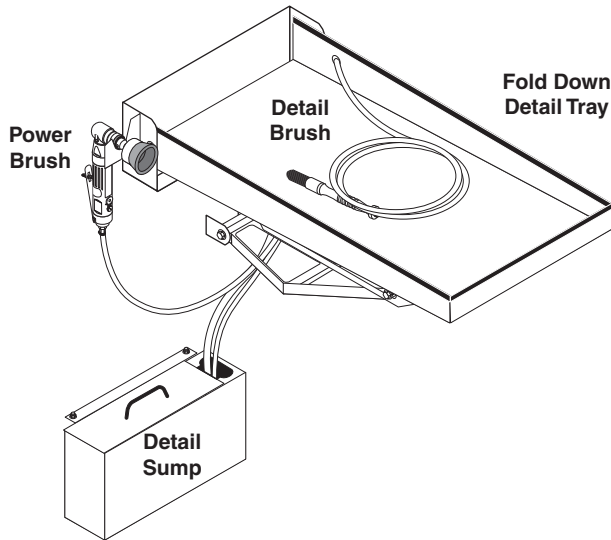

Detail Sump

The detail sump is located below the detail tray on the right side of the machine. It provides wash solution for the detail brush. The detail sump will hold approximately two gallons of wash solution.

NOTE: The detail tray and sump are standard components on the Deluxe Kit version of the models H2O-2840, H2O-2840, and H2O-2848. They are available as an option on the base models. To order a Deluxe Kit option package, contact your dealer or call customer service.

Power Brush (Optional)

The power brush is located on the right front corner of the machine. Refer to **Connect a Compressed-Air Line and Accessories** for detailed installation information.

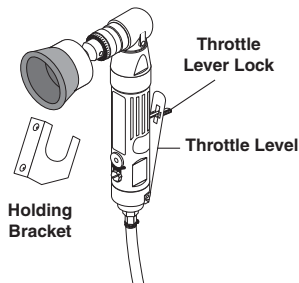

NOTE: The power brush is a standard component on the Deluxe Kit version of the models H2O-2840, H2O-2840, and H2O-2848. It is available as an option on the base models. To order a Deluxe Kit option package, contact your dealer or call customer service.

Using the Power Brush Option

WARNING: Particles dislodged by the power brush could cause serious injury to your eyes. Always wear approved eye protection when using the power brush.

AVERTISSEMENT: Les particules délogées par la brosse motorisée pourraient causer des blessures graves aux yeux. Toujours porter une protection oculaire approuvée lors de l'utilisation de la brosse motorisée.

With stiff stainless steel bristles turning at 1800 RPM, the power brush easily removes carbon deposits, old gasket material, or other tightly-adhered materials from parts before washing.

To turn on the power brush, position the air flow select valve appropriately, then push the power brush lever lock forward with your thumb and squeeze the throttle lever to control the speed of the brush.

Detail Brush and Flow Regulator

The detail brush is located on the right inside wall of the detail tray. The flow regulator is located on the right rear corner of the machine. The detail brush uses a continuous flow of cleaning solution through its nylon bristles to help you clean delicate or lightly soiled parts. The flow regulator controls the flow of cleaning solution through the detail brush.

WARNING: Hot, high-pressured cleaning solution could cause serious injury. Always wear rubber gloves and approved eye protection when handling hot cleaning solution.

AVERTISSEMENT: Une solution de nettoyage chaude haute pression pourrait causer des blessures graves. Toujours porter des gants en caoutchouc et une protection oculaire approuvée lors de la manutention de solution de nettoyage chaude.

Adjusting the Flow of Cleaning Solution

If you need to adjust the flow, pull out the flow regulator knob, then rotate it clockwise to increase the flow or counter-clockwise to decrease the flow. After adjusting, push the knob back in to lock it.

NOTE: The detail brush is a standard component on the Deluxe Kit version of the models 2840, and 2848. It is available as an option on the base models. To order a Deluxe Kit option package, contact your dealer or call customer service.

Oil Skimmer

The oil skimmer is located on the right rear corner of the machine. It automatically removes oil from the wash solution to prolong its useful life. Refer to **Using the Oil Skimmer** for detailed operating instructions.

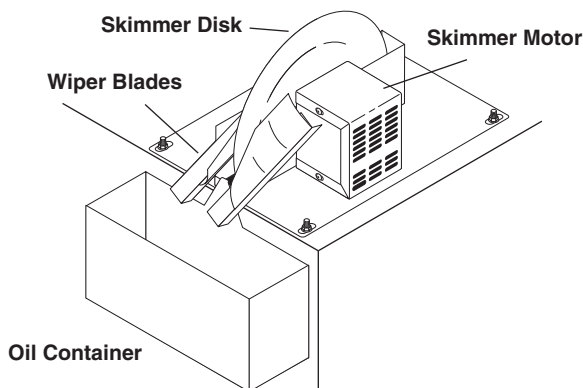

Water Level

Under typical operating conditions the machine loses 3 to 5 gallons of water per day to evaporation. It is important that you monitor and maintain the water level daily to minimize the risk of burning out the heating element or ruining the pump.

*NOTE: Add detergent each time you add water. Add detergent after you clean the sump chamber each month, and more frequently if your cleaning cycle maintenance period is more frequent, and if you notice specific low-detergent indicators (See **Detergents and Additives**).*

Automatic Water Fill (Optional)

The optional automatic water fill system automatically maintains a proper water level in the sump.

The automatic water fill system uses the low water shut-off proximity switches to open and close a water solenoid valve, which automatically maintains a proper water level in the sump. The figure below describes the operation of the automatic water fill system.

Low Water Shut-off

The low water shut-off system shuts down the machine if the wash solution in the sump chamber drops below a safe level. The system uses two proximity switches and a float rod mounted near the rear of the sump chamber to monitor the water level.

If the wash solution drops below the lower proximity switch, the low water indicator light on the control panel turns on and the system disconnects power to machine. To reset the system, add water to the sump until the low water indicator light turns off.

Automatic Water Fill Diagram:

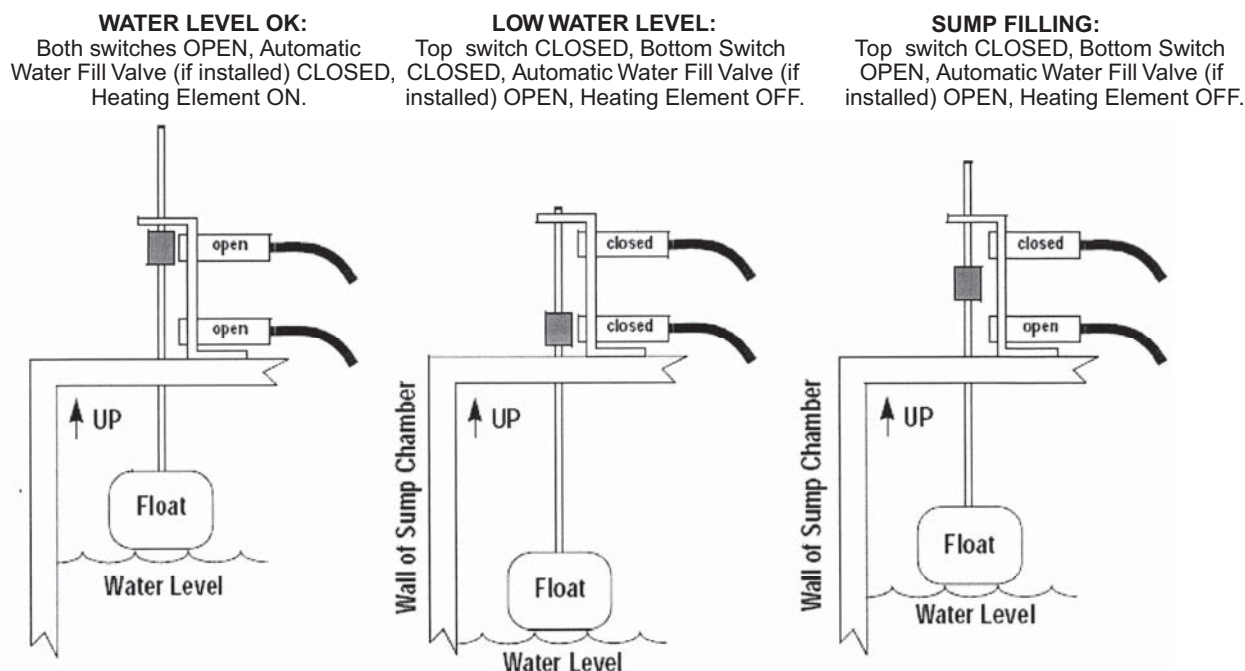

NOTE: If your machine is equipped with the optional automatic water fill feature, the sump will automatically fill when the water level drops below the lower low water proximity switch.

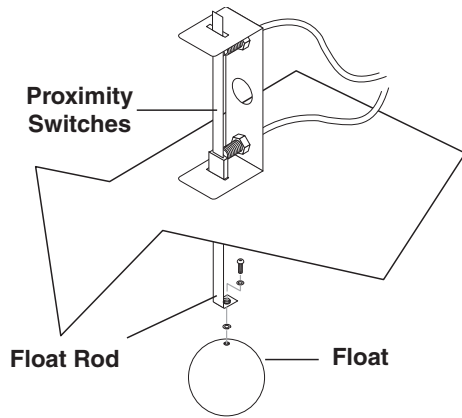

Filtration and Sump Sweep Systems (Optional)

The optional filtration and sump sweep systems reduce or eliminate the need to manually clean out the sump.

The filtration system continuously filters solid particles from the wash solution, and you can use the sump sweep system to periodically remove waste build up from the bottom of the sump chamber.

Filtration System (Optional)

The filtration system uses a filter canister with a nylon or polyester felt filter bag to continuously filter solid particles from the wash solution. The filter system includes pressure gauges which allow you to monitor the condition and performance of the filter bag inside the canister. Under typical operating conditions, the inlet and outlet pressure gauges read approximately 45 psi. As the filter bag becomes soiled, the outlet pressure decreases. If the difference between the inlet and outlet pressure is 15 psi or greater, stop the machine and clean or replace the filter bag (See **Cleaning the Filters**).

WARNING: Operating the machine with a clogged filter system could damage the filter bag. **STOP THE MACHINE IMMEDIATELY** if the difference between the inlet and outlet pressure is 15 psi or greater.

AVERTISSEMENT: Utiliser la machine alors que le système de filtration est obstrué risquerait d'endommager le sac du filtre. **ARRÊTER IMMÉDIATEMENT LA MACHINE** si la pression de sortie chute en deçà de 15 psi.

Sump Sweep System (Optional)

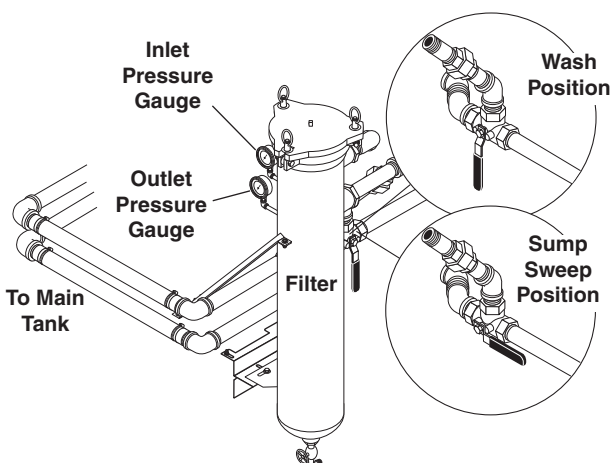

The sump sweep system uses a three-way valve to divert solution from the wash chamber to a spray bar on bottom of the sump chamber. The spray bar generates a high-pressure spray pattern that agitates the sump solution and suspends solid particles. The solution then flows through the filtration system which removes the solid particles (See **Cleaning out the Sump**).

Detergents And Additives

Manufacturer's detergents are the only detergents approved for use with our automatic parts washers. They are specially formulated with rust inhibitors and anti-foaming agents to optimize performance and minimize maintenance. The use of any other detergent during the warranty period will void the warranty.

To monitor the approximate concentration of detergent in the wash solution, periodically examine the wash solution in the sump chamber for the following indicators:

- **Rust inside the machine:** not enough detergent
- **Excessive foaming:** not enough detergent
- **Thick, white residue on parts after washing:** too much detergent.

To maintain proper concentration under typical conditions, add detergent each month after cleaning the sump chamber. Follow recommended detergent quantities. Use a pH kit to determine the proper amount of detergent to use. If you need help interpreting test results, contact customer service.

Rust Inhibitor Additive

Factory detergents protect the entire inside of your machine against the degenerative effects of water evaporation. A rust inhibitor additive actually evapo-

rates with the water and continuously coats and protects metal surfaces, even while your machine is sitting idle. For more information, contact your distributor or call customer service.

Preparing The Machine For Use

Before you begin to wash parts, it is important that you properly prepare the machine. Before you begin to use the machine each day:

- check the water level and add water to the sump tank if necessary;
- check sump water cleanliness and run skimmer as-needed to clean sump water surface;
- heat the water to operating temperature;
- add detergent if necessary (see **Detergents**);
- verify that none of the spray nozzles are clogged; and
- clean the debris screen.
-

Washing Parts

The following procedure assumes that the heater is on and the sump water is at operating temperature.

To wash parts, perform the following procedure.

WARNING: Hot, high-pressured cleaning solution could cause serious injury. Always wear rubber gloves and approved eye protection when loading and unloading the machine.

AVERTISSEMENT: Une solution de nettoyage chaude haute pression pourrait causer des blessures graves. Toujours porter des gants en caoutchouc et une protection oculaire approuvée lors du chargement et du déchargement de la machine.

1. Load parts into the machine.

Load large, heavy parts directly onto the turntable.
Secure large, light parts (valve covers for example) to the turntable using suitable rubber tie-downs.
Load small, light parts into the small parts basket.

NOTE: For optimum cleaning performance, provide a slight clearance between parts to allow adequate flow of cleaning solution around and between them.

2. Close and latch the door.
3. Set the wash cycle timer to between 1 and 60 minutes for a timed wash cycle, or set it to **Hold** for a continuous wash.
4. When the machine automatically stops (or after you manually stop the wash cycle), open the door and wait a few moments to allow the parts to cool and dry before removing them. Most parts will flash-dry in seconds.

Using the Oil Skimmer System

The oil skimmer system is most effective if used when the cleaning solution in the sump is cool. The frequency at which you must remove the oil from the wash solution will depend on machine usage. Under typical operating conditions you may need to remove the oil every day. If the oil skimmer runs longer than 10-15 minutes, the detergent and vapor rust inhibitor content in the sump should be checked. The detergent and inhibitor can be removed with extensive use of the skimmer, so be certain to check chemical levels after running the skimmer to determine if you require a higher frequency chemical maintenance cycle than weekly.

IMPORTANT: The skimmer motor is equipped with a thermal overload switch which protects the skimmer from overheating. If you attempt to use the oil skimmer system when the wash solution is hot, the thermal overload will probably trip and the motor will shut off until it cools. Under normal skimming conditions (when the wash solution is cool) the thermal overload should not trip.

To remove oil from the cleaning solution, perform the following procedure:

1. Allow the machine to sit idle for at least 30 minutes to allow the oil to float to the surface of the wash solution.
2. Ensure that the oil collection container is in place, then turn the skimmer switch to the "ON" position.

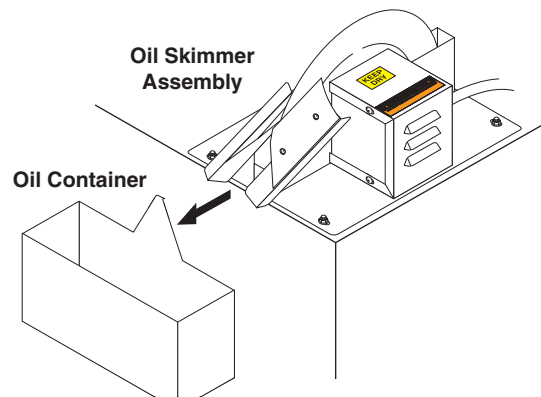

3. Allow the oil skimmer to operate until it is no longer extracting oil from the cleaning solution.

Tip: While extracting oil from the cleaning solution, oil will flow off the wiper blades in a fine continuous stream. Water will flow off the blades in droplets. Once droplets begin to flow off the wiper blades, stop the skimmer motor.

4. Dispose of the oil in the collection container in accordance with local and state regulations, then replace the container.

Shutting Down The Machine

To shut down the machine at the end of the day:

- set the wash cycle timer to **OFF**;
- set the heater timer to **OFF**; and
- shut off the compressed air at the supply line (if installed).

WARNING: If the heater is left on unattended, the wash solution could evaporate and the oil and grease in the sump chamber could catch fire.

AVERTISSEMENT: Si le chauffe-eau est laissé sous tension sans surveillance, l'eau pourrait s'évaporer et l'huile et la graisse dans la chambre de lavage pourrait prendre feu.

- For periods of extended shut-down, disconnect all power to the machine.

NOTE: Perform rust preventative treatment on mild steel units prior to extended storage.

- If your machine is equipped with an optional 24-hour, 7-day heater timer, periodically verify the settings to prevent inadvertent unattended operation.

Maintaining The Machine

To ensure optimum performance and trouble-free operation, observe the following maintenance schedule consistently.

Daily Maintenance

- Check the water level; add water if necessary.
- Clean the debris screen.
- Remove oil from the wash solution using the oil skimmer system (See **Using the Oil Skimmer System**).

Weekly Maintenance

- Examine the spray nozzles; clean and align if necessary (See **Cleaning and Aligning the Spray Nozzles**).
- Wipe down the exterior of the machine using degreaser spray and a soft, damp cloth. **TO PREVENT ELECTRICAL COMPONENT FAILURE, DO NOT SPRAY THE MACHINE WITH WATER.**
- Check detergent level to maintain proper concentration level which decreases as water is added. The pH level of this detergent must be in accordance with the detergent manufacturer's recommendation.

NOTE: Degreaser spray and a damp cloth will usually remove all dirt and grime from the machine. For particularly stubborn soap deposits, use a soft cloth dampened with warm solution from the wash chamber.

Monthly Maintenance

- Clean out the sump chamber and detail sump (See **Cleaning out the Sump**).
- Lubricate the door spindle using high-quality automotive grease. Add grease until it begins to flow out of the joint beneath the grease fitting, then wipe excess grease from the fitting and the joint.

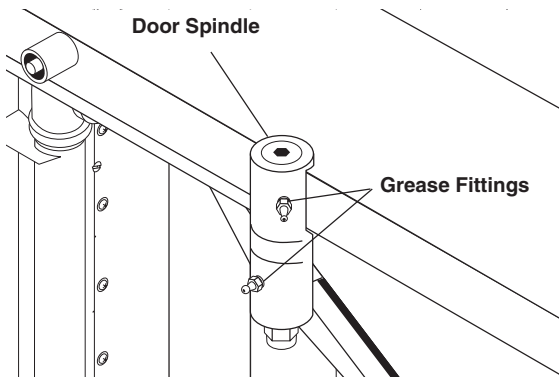

Semi-Annual Maintenance

- Lubricate the pivot pin on the turntable motor assembly with machine oil or anti-seize.

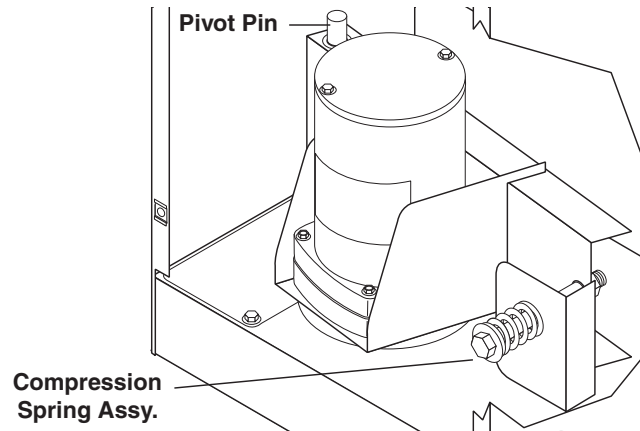

- Lubricate the upper and lower pump bearings using high-quality automotive grease. **Do not over grease the bearings**; over greasing could cause premature failure.
For 5HP pumps, add 1–2 strokes of grease every six months; for pumps larger than 5HP, add 2–3 strokes of grease every year.

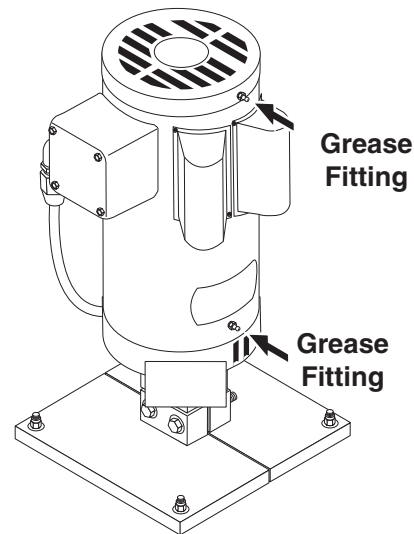

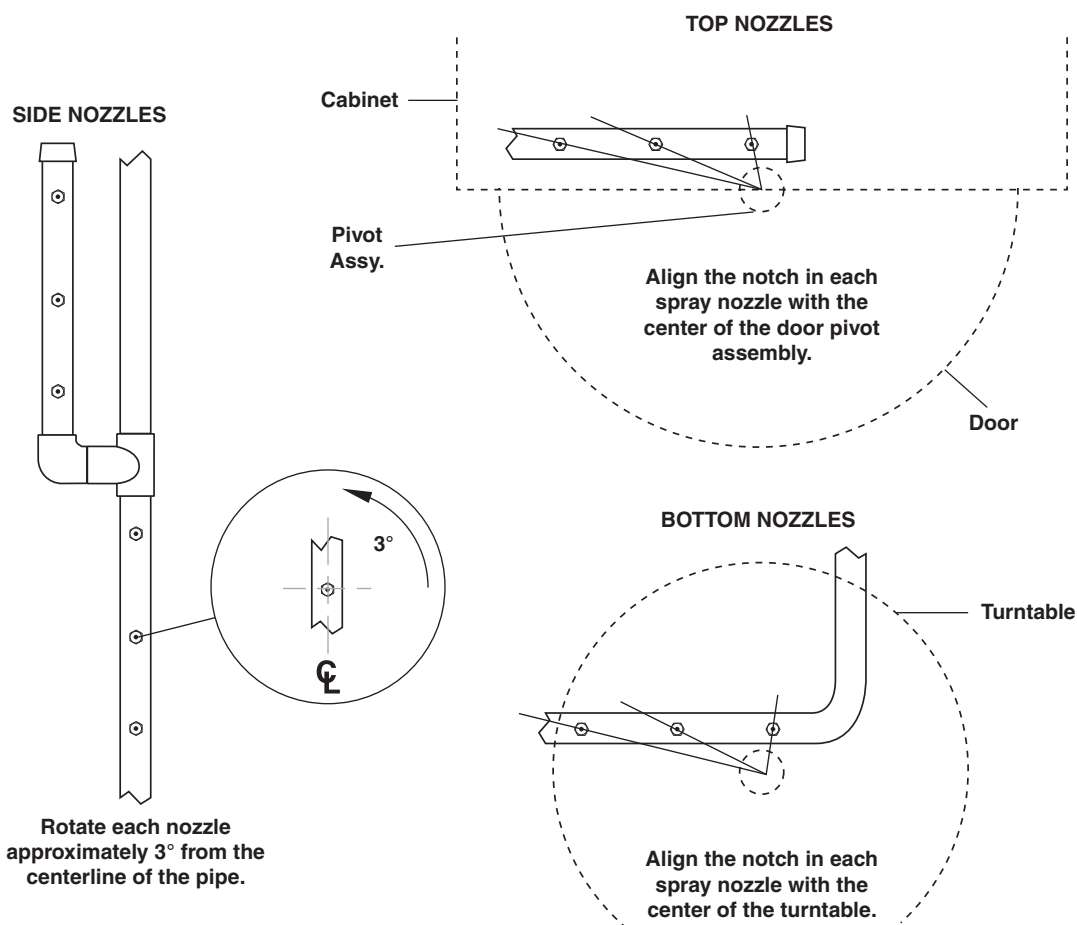

Cleaning and Aligning the Spray Nozzles

To ensure optimum cleaning performance, it is important that you examine the spray nozzles periodically and clean and align them if necessary.

To clean a plugged nozzle, remove it from the spray pipe and use a small wire brush to free the nozzle of any obstructions. When you replace the nozzle on the spray pipe, make sure you align it according to the figure on top of the page to maintain a proper spray pattern.

NOTE: The spray nozzles are sized and positioned to optimize the distribution of cleaning solution in the wash chamber. If you remove the nozzles make sure you replace them in the correct position on the appropriate pipe.

Cleaning out the Sump

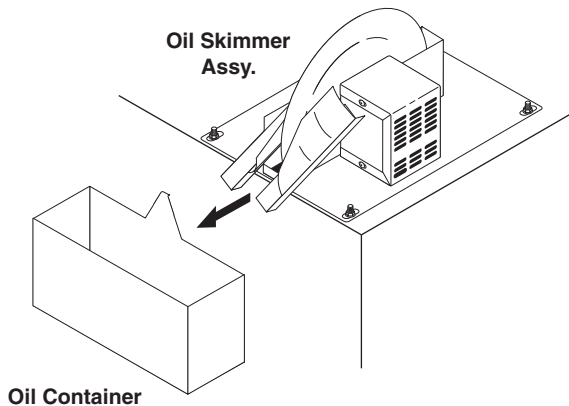

Filtration and Sump Sweep System

NOTE: The effectiveness of the filtration and sump sweep system for cleaning out the sump will depend on the type of filter bag(s) you use in the filter canister(s). If you find that the filtration and sump sweep systems do not adequately clean the sump on your machine, contact your distributor or customer service for other filter bag recommendations.

To clean out the sump using the optional filtration and sump sweep system, perform the following procedure:

1. If your machine is equipped with a detail sump, dump the contents of the detail sump into the main sump chamber.
2. Remove oil and grease from the cleaning solution using the oil skimmer system (See **Using the Oil Skimmer System**).
3. Position the three-way wash solution valve as shown.

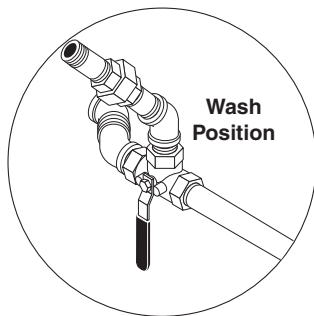

4. Close and latch the door.
5. Run the machine through a 30-minute wash cycle.

NOTE: While the sump sweep is operating, monitor the outlet pressure on the filter system to ensure that it does not drop below 30 psi. If the pressure drops below 30 psi, immediately stop the machine and

*either clean or replace the filter bag(s) (See **Cleaning the Filters**).*

6. After the machine stops, position the three-way wash solution valve as shown.

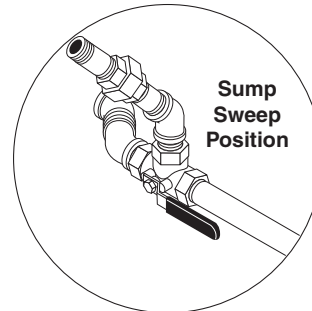

7. Add the appropriate amount of detergent and run the machine through a 30-minute wash cycle. Use a pH kit to determine the proper amount of detergent to add.

NOTE: Our detergent is the only detergent approved for use with our automatic parts washers. It is specially formulated with rust inhibitors and anti-foaming agents to optimize performance and minimize maintenance. The use of any other detergent during the warranty period will void the warranty.

Manual Sump Clean out

To manually clean out the sump, perform the following procedure:

1. If your machine is equipped with a detail sump, dump the contents of the detail sump into the main sump chamber.
2. Remove oil and grease from the cleaning solution using the oil skimmer system (See **Using the Oil Skimmer System**).
3. If your machine is equipped with the Auto-Fill feature, turn off the water at the supply line.
4. Remove both sump covers, then drain the wash solution from the sump chamber. To drain the solution either use the sump drain or a small submersible pump.
5. Remove sand and other debris from the bottom of the sump chamber and the detail sump. To remove the debris, either flush it out through the sump drain or vacuum it out using a wet/dry vac. Dispose of the debris in accordance with applicable local, state, and federal regulations.

NOTE: Take special care to ensure that the heating element is free of debris. A buildup of debris around the element will decrease heating performance and may cause the element to overheat and fail.

6. Refill the sump with fresh clean water.
7. Replace the sump covers and heat the wash water to operating temperature.
8. Add the appropriate amount of detergent and run the machine through a 30-minute wash cycle. Use a pH kit to determine the proper amount of detergent to use.

NOTE: Our detergent is the only detergent approved for use with our automatic parts washers. It is specially formulated with rust inhibitors and anti-foaming agents to optimize performance and minimize maintenance. The use of any other detergent during the warranty period will void the warranty.

Cleaning the Filters

Our filtration systems are available in single or multiple canister configurations. Each canister uses a nylon or polyester felt filter bag to remove solid particles from the wash solution. Nylon bags are reusable; polyester felt bags are designed for a single use. To clean or replace the filters, perform the following procedure:

1. Turn off the machine and open the door.

2. If your machine is equipped with the Auto-Fill feature, turn off the water at the supply line.
3. Slowly unscrew the pressure-release plug on the lid of the filter canister to release the pressure in the filtration system.

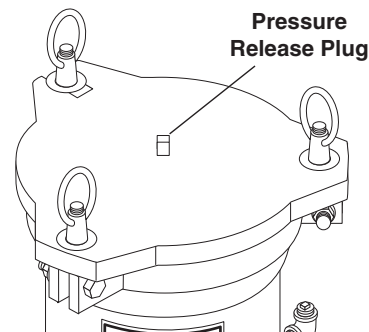

4. Loosen the three lid nuts, then swing the lid free of the canister.

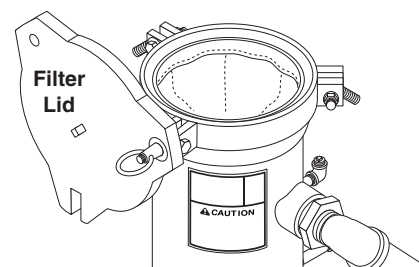

5. Remove and empty the filter bag and screen.

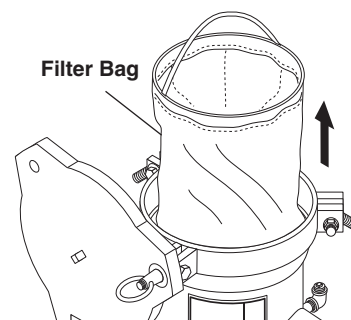

6. If you are using a nylon filter bag, you can clean and reuse it several times before replacing it. If you are using a polyester felt filter bag, you must replace it. Contact your distributor or call customer service for filter bag recommendations and ordering information.
7. Replace screen and filter bag in the filter canister.
8. Install and tighten the lid.
9. Tighten the pressure-release plug.
10. Turn on machine and continue washing.

Repairing The Machine

The following procedures outline the steps necessary to replace specific items on the machine that could wear out or otherwise fail.

Heating Elements

Required Tools and Equipment

- 5/16" wrench or socket
- 2" socket and breaker bar
- sealing tape or compound
- medium phillips-head screwdriver

Replacement Procedure

1. Disconnect power to the machine.
2. Drain the wash solution from the sump.
3. Remove the cover from the heating element and thermostat enclosure (two 5/16" screws).
4. Detach the power leads from the heating elements, taking care to mark them for reassembly.

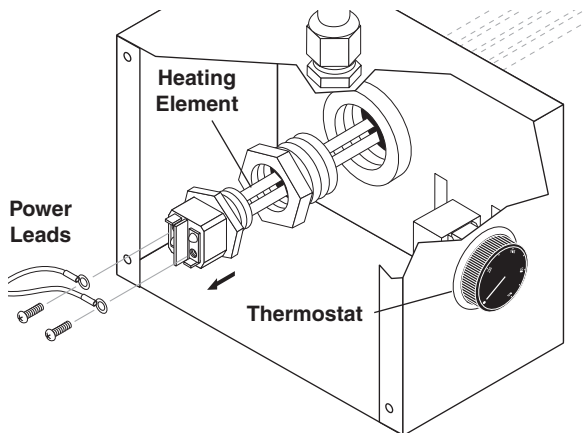

5. Using a 2" socket and breaker bar, unscrew the heating element(s) from the machine.

NOTE: Since the heating element is in continuous contact with the cleaning solution the threads may corrode slightly. The element may be difficult to remove. When you install a new heating element, use sealing tape or compound on the threads to deter corrosion.

6. Install the new heating element(s). Installation is the reverse of removal.

Thermostat

Required Tools and Equipment

- 5/16" wrench or socket
- medium phillips-head screwdriver
- large flat-head screwdriver

Replacement Procedure

1. Disconnect power to the machine.
2. Remove the cover from the heating element and thermostat enclosure (two 5/16" screws).
3. Remove the thermostat knob and the two screws to remove the thermostat from the housing.

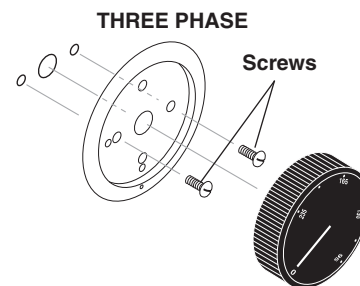

4. Detach the electrical leads from the thermostat .

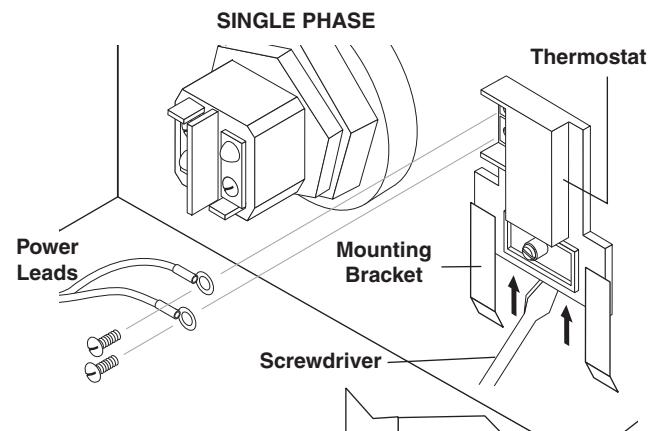

5. Remove the thermostat from the machine.
6. Install the new thermostat. Installation is the reverse of removal.

Turntable Motor

Required Tools and Equipment

- 5/16" wrench or socket
- 1/8" hex key
- medium phillips-head screwdriver

Replacement Procedure

1. Disconnect power to the machine.
2. Remove the main electrical panel cover (eight screws; use a 5/16" wrench or socket). The turntable motor assembly is located just below the electrical panel.
3. Remove the drive pulley access plate.

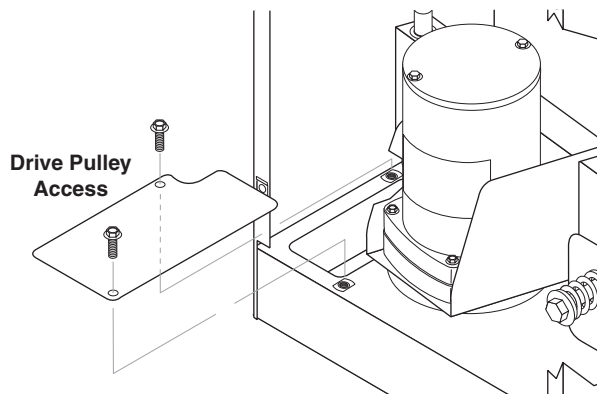

To remove the plate, remove the two screws using a 5/16" wrench or socket, then slide the plate toward the rear of the machine through the slot in the housing.

4. Remove the compression spring from the motor assembly using a 9/16" wrench and socket.

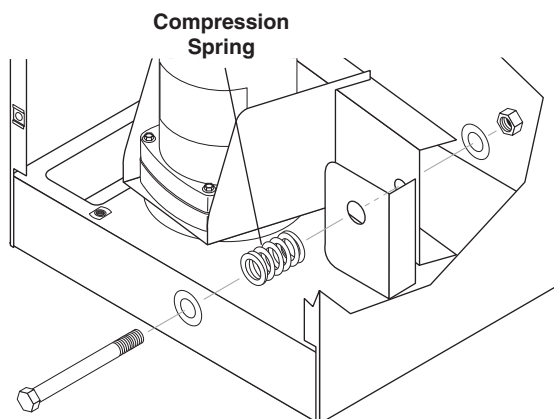

5. Push the motor assembly toward the front of the machine, then reach into the drive pulley access hole with your fingers to free the chain from the

drive pulley. Take care not to let the chain slip into the wash chamber. Use a piece of wire to secure the chain while you replace the motor.

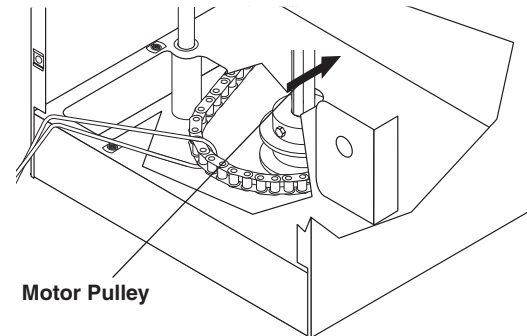

6. Disconnect all power leads from the motor, taking care to mark them for reassembly.
7. Raise the motor and bracket to remove the assembly from the pivot pin.
8. Use a 3/32" hex key to remove the pulley and steam shield disk from the drive motor shaft, then remove the four mounting screws holding the motor to the mounting bracket.

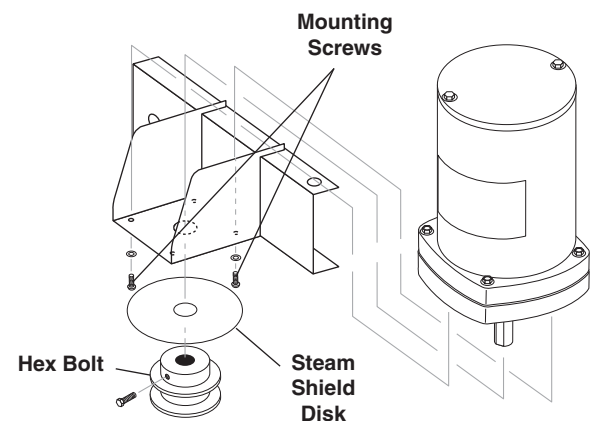

9. Install the new motor. Installation is the reverse of removal.

Timers and Switches on the Control Panel

Required Tools and Equipment

- 5/16" wrench or socket
- 1/2" wrench or deep socket
- small phillips-head screwdriver
- small flat-head screwdriver

Replacement Procedure

1. Disconnect power to the machine.
2. Remove the control panel face plate (four 10/32" screws).

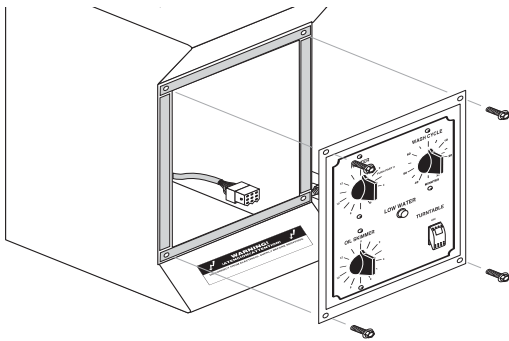

3. Disconnect the wiring harness from the rear of the face plate.
4. Remove the knob from the timer you wish to remove.
5. Remove the two screws, retaining nut, and o-ring that hold the timer switch to the control panel.

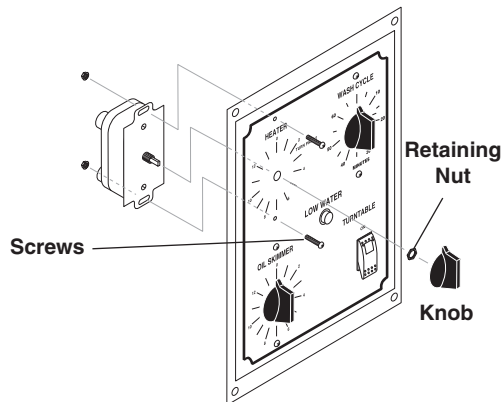

6. Detach the power leads from the timer.
7. Attach the power leads to the new timer.

8. Install the new timer. Installation is the reverse of removal.

Oil Skimmer Motor

Required Tools and Equipment

- 5/16" wrench or socket
- 1/2" wrench or socket
- small phillips-head screwdriver

Replacement Procedure

1. Disconnect power to the machine.
2. Remove two 5/16" screws to remove the skimmer motor cover.

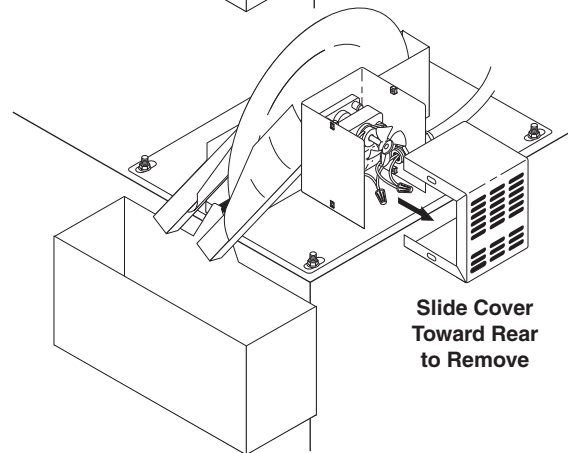
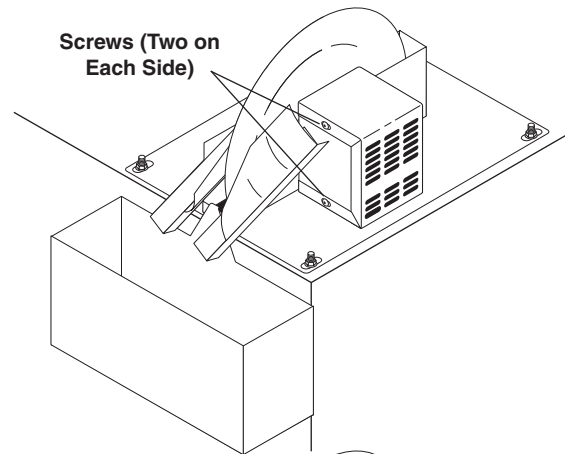

- Remove the two wire nuts from the power leads to disconnect the leads from the motor, and disconnect the conduit from the motor housing.

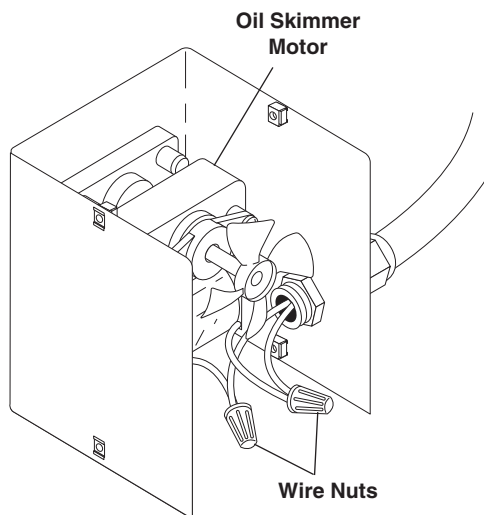

- Remove the four 1/2" bolts from the skimmer assembly mounting plate to remove the skimmer

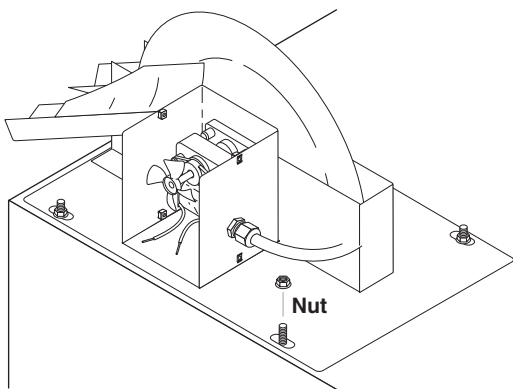

assembly from the machine.

- Remove the two screws from the center of the skimmer disk to detach the disk from the skimmer assembly. To remove the disk, disengage it from the center pin, then slide it down.

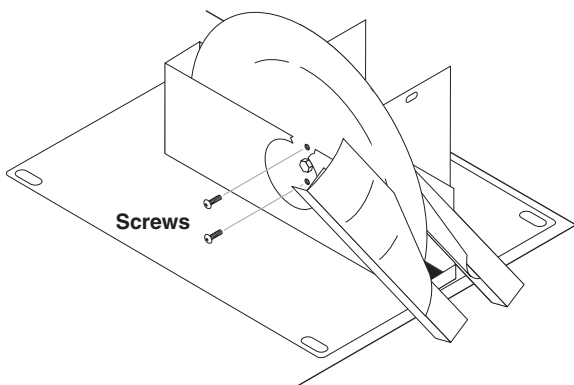

- Remove the three screws from the skimmer motor mounting plate to remove the motor from the skimmer assembly.

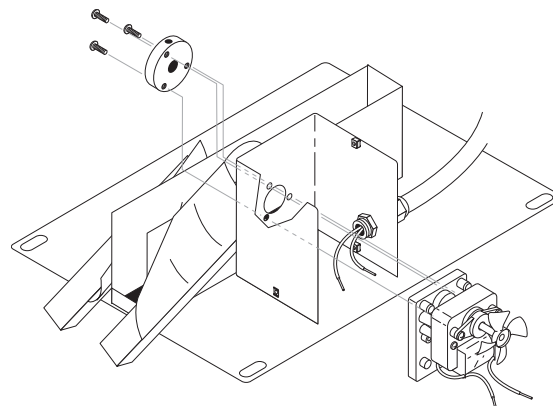

- Reassemble the skimmer assembly and replace it on the machine. Assembly is the reverse of removal.

Troubleshooting

Troubleshooting The Electrical System

To troubleshoot the electrical system use the following diagrams to eliminate the possibility of a blown fuse or a bad connection, then refer to Testing Individual Components to determine which component is causing the problem.



DANGER: Keep water away from electric wiring or fatal electric shock may result.

DANGER: Garder le d'eau à l'écart de tout câblage électrique ou des chocs électriques mortels pourraient survenir.

- Electrical troubleshooting should be performed by qualified personnel only.
- Avoid contact with power leads, terminals and fuses when power is connected.
- Disconnect power to machine before removing fuses or other electrical components.

Troubleshooting a Single Phase Panel

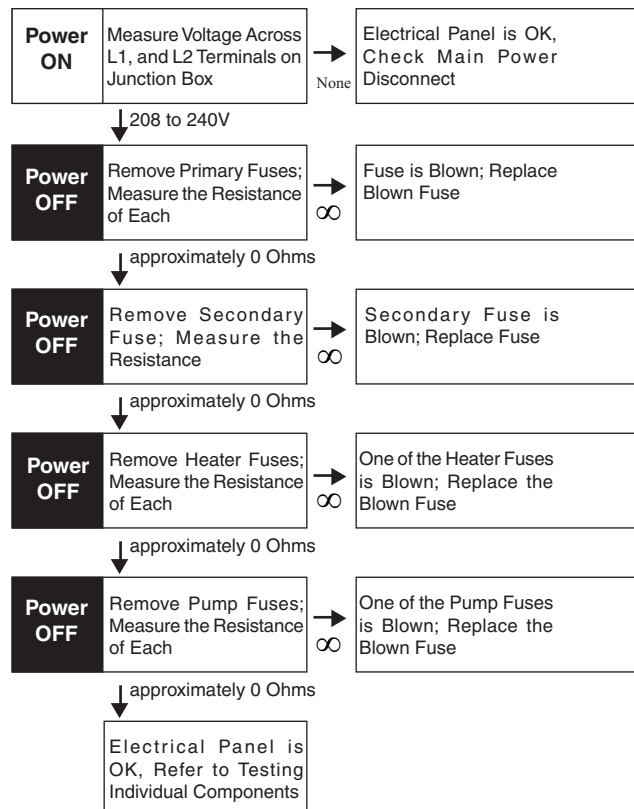
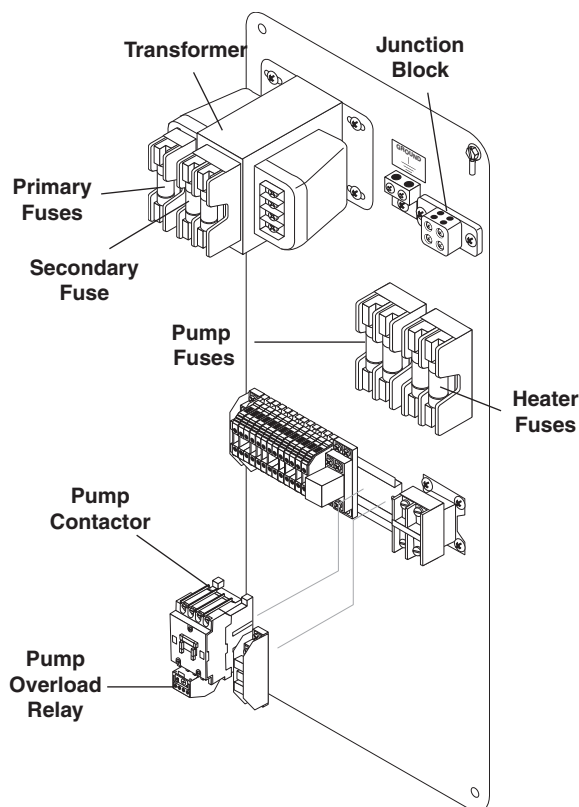

Troubleshooting a Three Phase Panel

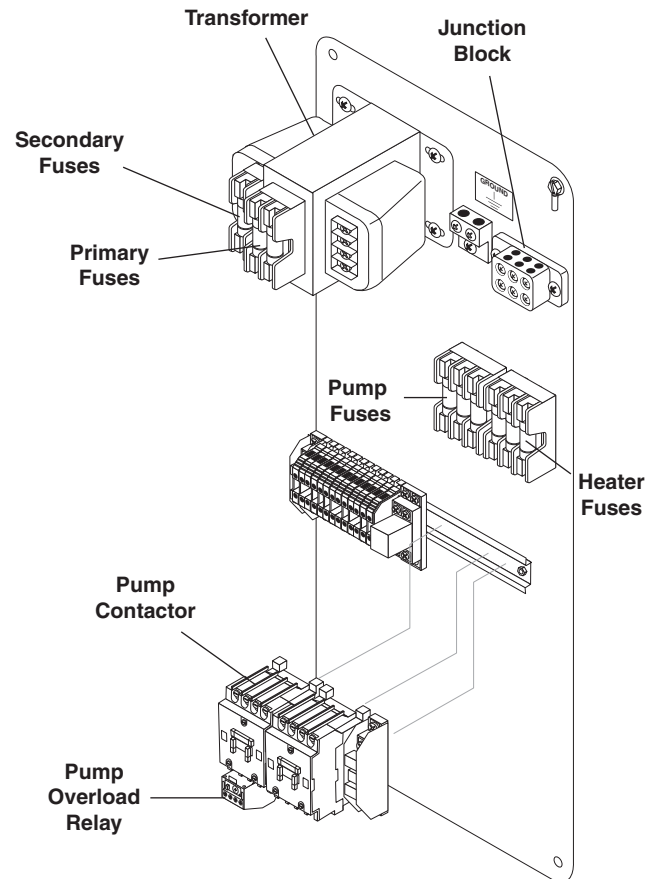
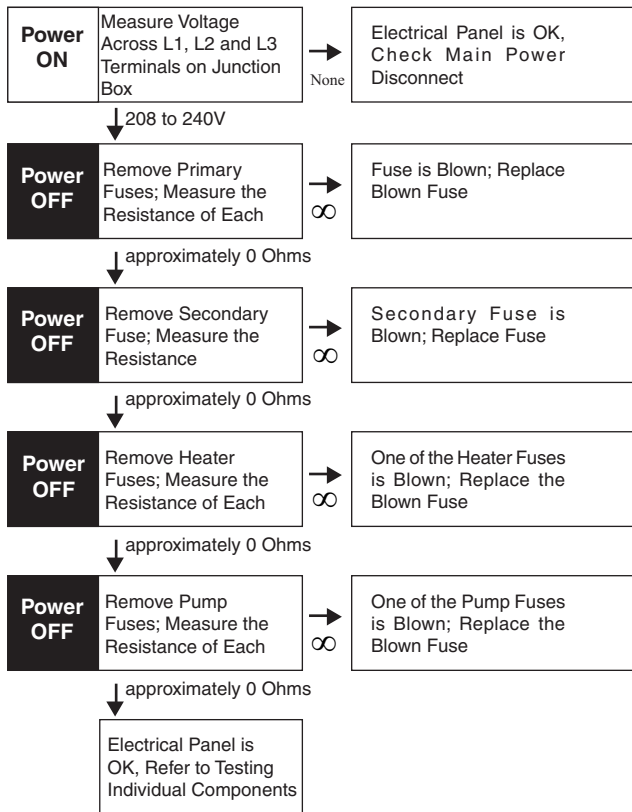

Testing Individual Components

NOTE: The following troubleshooting procedures require the use of a volt/ohm meter. If you are not familiar with using a volt/ohm meter do not attempt to perform the following troubleshooting procedures. If you need assistance please contact your distributor or call a customer service representative.

Wash Cycle, Heater, and Oil Skimmer Timers

1. **Disconnect power to the machine.**
2. Remove the timer from the control panel and disconnect all wires (See **Timers and Switches on the Control Panel**).
3. With the timer in the **OFF** position, test for continuity using an ohm meter.
If there **is** continuity the timer is no longer functional; replace the timer.
4. With the timer in the **ON** position, test for continuity using an ohm meter.
If there **is not** continuity the timer is no longer functional; replace the timer.

Door Safety Switch

1. **Disconnect power to the machine.**
2. Remove the switch from the rear of the machine and disconnect all wires (See **Door Safety Switch**).
3. With the switch fully open (not depressed), test for continuity.
If there **is** continuity the switch is no longer functional; replace the switch.
4. With the switch fully closed (depressed), test for continuity.
If there **is not** continuity the switch is no longer functional; replace the switch.

Single Phase Heating Element

1. **Disconnect power to the machine.**
2. Remove the cover from the heating element and thermostat enclosure (four screws; use a 5/16" wrench or socket).

3. Detach the power leads from the heating element.

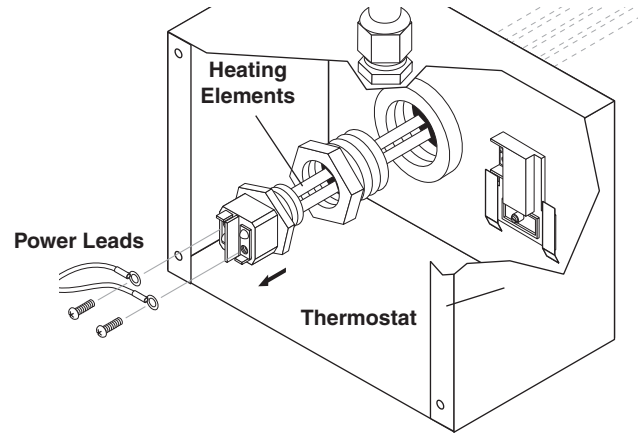

4. Use an ohm meter to measure the resistance of the heating element. The single-phase resistance should be approximately 10 Ohms; if not, replace the heating element (See **Heating Element**).

Three Phase Heating Element

A three phase heating element is a complex component. Please contact your customer service representative for testing instructions.

Single Phase Thermostat

1. **Disconnect power to the machine.**
2. Remove the cover from the heating element and thermostat enclosure (four screws; use a 5/16" wrench or socket).
3. Detach the power leads from the thermostat.

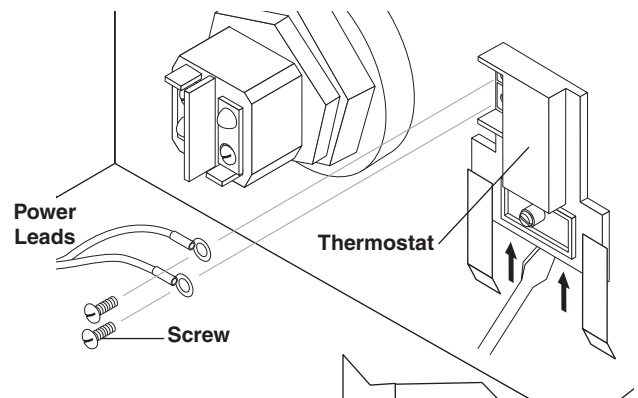

4. Using a large flat-head screwdriver, pry the thermostat out of the mounting bracket, then remove it from the machine.

5. Set the thermostat to 120°F, warm it to just above 120°F, then test for continuity.

If there **is** continuity, the thermostat is no longer functional; replace the thermostat.

6. Allow the thermostat to cool to room temperature, then test for continuity.

If there **is not** continuity the thermostat is no longer functional; replace the thermostat.

Three Phase Thermostat

A three phase thermostat is a complex component. Please contact your customer service representative for testing instructions.

Start Capacitor

1. **Disconnect power to the machine.**
2. Remove the main electrical panel cover (eight screws; use a 5/16" wrench or socket). The turntable motor assembly is located just below the electrical panel.
3. Visually inspect the start capacitor. If it appears swollen or deformed, it is no longer functional; replace the start capacitor.

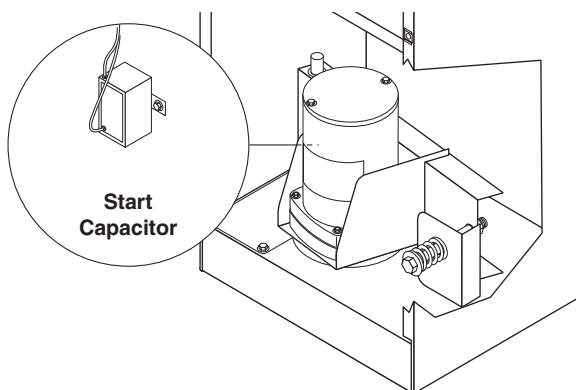

4. If the start capacitor is not visibly failed, remove it from the motor bracket, disconnect the wires, and test it for shorts using an ohm meter.

If the ohm meter reads approximately 1 Ohm, the start capacitor is no longer functional; replace the start capacitor.

PROBLEM	POSSIBLE CAUSE	SOLUTION
POOR CLEANING PERFORMANCE	Parts are obstructing each other	Check the position of parts on turntable; position parts to allow flow of cleaning solution around and between them.
	Low water level in sump	Check sump water level and add water if necessary.
	Clogged or improperly aligned spray nozzles	Check the spray nozzles for obstructions and alignment; clean and align if necessary.
	Wash solution is not properly heated	Check wash solution temperature; temperature should be between 160°F and 180°F (See Wash Solution Is Not Heating Section)
	Low detergent concentration less than 9 pH. Should be 10-11 pH	Add 1-2 scoops of detergent and observe cleaning performance; add 1-2 scoops if necessary.
	Pump is not operating properly	See Pump Does Not Operate Properly section.
WASH SOLUTION IS NOT HEATING	Blown fuse	Check the electrical panel for a blown fuse.
	Thermostat is set incorrectly	Check the thermostat setting; set to 180°F.
	Line voltage is too low	Contact a licensed electrician to verify that the line voltage matches unit voltage.
	Excess debris is built up around heating element	Check for debris build up around the heating element; clean out if necessary. (See Cleaning Out the Sump Section).
	Failed heat timer	Test the heater timer; replace if necessary.
	Failed thermostat	Test the thermostat; replace if necessary (See Thermostat Section).
	Failed heating element	Test the heating element; replace if necessary.
FOAMING	Machine operating with cold water	Bring water up to correct temperature.
	Grease, high detergent motor oils, transmission oil, gear lubes, synthetic oils	Do not place oil pan or transmission pan
	Not enough detergent	Add more detergent, check pH level. Use Defoamer.
WHITE POWDER ON PARTS	Solution is old	Change sump water and recharge with fresh detergent and vapor corrosion inhibitor.
	Water hardness and TDS (totally dissolved solids)	Use a water softener and/or change your sump water more frequently.
	Large parts can dry before solution runs off, leaving powdery residue	Monitor soap concentration and correct as needed.
WASH SOLUTION IS TOO HOT	Thermostat is incorrectly installed	Check the thermostat to ensure that it is correctly installed into the mounting bracket. (See Thermostat Section).
	Failed thermostat	Replace the thermostat (See Thermostat Section).

PROBLEM	POSSIBLE CAUSE	SOLUTION
MACHINE FAILS TO START WHEN "WASHING PARTS" PROCEDURE IS FOLLOWED	Main power disconnect is off	Verify that no service is being performed on the machine, then turn the main power disconnect on.
	Lid/door is not closing properly	Check the lid/door closure safety switch; adjust if necessary.
	Failed lid/door closure safety switch	Test the lid/door closure safety switch; replace if necessary (See Adjusting the Lid/Door Safety Switch).
	Failed washer cycle timer	Test the wash cycle timer; replace if necessary (See Lid/Door Safety Switch).
	Pump is not operating properly	See Pump does not operate properly section.
TURNTABLE DOES NOT OPERATE PROPERLY	Parts are obstructing turntable rotation	Check for parts obstructing rotation of the turntable; rearrange if necessary.
	Drive chain is not on the drive pulley	Check drive chain; realign on drive pulley if necessary.
	Turntable motor compression springs are not installed	Check the turntable motor compression springs; install if necessary (See Turntable Motor Assembly).
	Blown fuse	Check electrical panel for blown fuse; replace if necessary.
	Failed wash cycle timer	Test the electrical panel to eliminate the possibility of a blown fuse then contact a licensed electrician or a service representative to test the turntable motor.
PUMP DOES NOT OPERATE PROPERLY	Low water level in sump	Check sump water level; add water if necessary.
	Pump intake is plugged	Check pump intake for obstructions; clean out if necessary.
	Pump overload relay is tripped	Reset the motor overload relay.
	Blown fuse	Check electrical panel for a blown fuse; replace if necessary.
	Line voltage is too low	Contact a licensed electrician to verify that the line voltage matches unit voltage.
	Pump is failed	Test the electrical panel to eliminate the possibility of a blown fuse then contact a licensed electrician or a customer service representative to test the pump motor.
OIL SKIMMER DOES NOT OPERATE PROPERLY	Blown fuse	Check electrical panel for a blown fuse; replace if necessary.

PROBLEM	POSSIBLE CAUSE	SOLUTION
OIL SKIMMER DOES NOT OPERATE PROPERLY (CONTINUED)	Skimmer blades are too tight	Turn on the skimmer motor and observe the contact between the skimmer blades and the skimmer disk. If the blades skip, bind, or leave a significant scratch on the disk, they are too tight. To loosen the blades, gently bend them away from the skimmer disk.
	Cooling fan on skimmer motor is jammed	Turn off power to machine, remove skimmer motor housing, ensure that cooling fan is free of obstructions.
	Failed skimmer timer	Test the skimmer timer; replace if necessary (See Wash Cycle, Heater, and Skimmer Timers).
	Failed skimmer motor	Contact a licensed electrician to test the motor; replace if necessary.
LID/DOOR LEAKS	Lid/Door closure safety switch is not adjusted properly	Check the lid/door closure safety switch; adjust if necessary.
INTERIOR OF MACHINE IS RUSTING	Low detergent/vapor corrosion inhibitor concentration or improper detergent usage	Our detergents, when used at proper concentrations of 10 to 12 scoops (20 to 24 cups) per 50 gallons of water, contains adequate rust inhibitors to prevent rust, check vapor corrosion inhibitor concentration on chemical bottle for correct amount to add. Verify that you are using our detergents at the correct concentration.
	Condensation on door and cabinet causing rust during idle periods	Leave door open.

CUDA[®]
Kärcher Group

8.930-370.0 • Printed in U.S.A.