

MACK PINNACLE







# CONQUER THE ENDLESS HIGHWAY

The Mack® Pinnacle™ represents the best in truck engineering. From a lightweight-yet-strong frame specially designed for heavy loads, steep grades and long hauls to a powerful and fuel-efficient MP™ engine that delivers the brawn you need to maximize payload, this tractor is built to boost profits.

# BUILT TO FIT THE WAY YOU WORK

From our popular DayCab model to an army of sleepers, the Mack® Pinnacle™ offers a comfort level that fits every type of driver. Our DayCab is best suited for local trips while our 48- and 56-inch flat-top sleeper models are ideal for overnight hauls or day trips with long waits. Our 60- and 70-inch mid-rise sleepers are ideal for regional hauling. The 70-inch high-rise sleeper is spacious, features plenty of headroom and helps drivers make long-distance runs comfortably. All of our sleeper models are loaded with amenities to make life on the road easier.

The Pinnacle tractor in an axle back configuration (shown this page) boasts sleek lines that look good and improve aerodynamics. And the axle positioning delivers maximum maneuverability as the front axles are set back on the frame to improve the turning radius.



DAYCAB



48" FLAT-TOP



56" FLAT-TOP



60" MID-RISE



70" MID-RISE



70" HIGH-RISE

**AERODYNAMIC DESIGN:** The Mack Bulldog® sits low on Pinnacle's sloped hood providing improved aerodynamics on the road and excellent visibility. And the larger radiator opening provides better cooling with less fan engagement.

**DURABLE HEADLIGHTS:** The LEXAN® headlight covers are impact resistant and offer easy access for replacing bulbs without a single tool.

**VERSATILE BUMPER:** The durable bumper is designed with dual tow clevises, and is also equipped with fog lights for better visibility in inclement weather.

**SPLASH SHIELDS:** Hood splash shields keep the engine compartment clean extending component life, and they lift with the hood to create more room for vehicle maintenance and service.

**DURABLE HOOD:** Hood isolators allow the hood to flex independently from the cab for increased durability over rough terrain.

**GALVANIZED STEEL CAB:** Pinnacle's durable galvanized steel cab is mounted on airbags and shocks and stabilized with sway bars, so while the truck soaks up the rough stuff, the driver stays comfortable, rested and productive.

**RUBBER-SEALED WINDSHIELD:** A two-piece windshield is isolated in a rubber seal, which puts less stress on the windshield and makes it easier to replace at less cost.

**COLLAPSIBLE MIRRORS:** Collapsible mirrors fold to eliminate door sheet metal damage in tight jobsite conditions. Heated, lighted and motorized mirrors are available.





**EASY CAB ENTRY:** Sculpted self-cleaning steps and a full-size externally-mounted grab bar provide an extra measure of safety getting in and out of the cab.

**UNDER CAB MOUNTED COMPONENTS:** The air tanks and battery box are neatly mounted under the cab, and a full selection of aluminum or steel fuel tanks are available to fit your needs. When Pinnacle™ is outfitted with fuel-tank fairings, all components are not only protected, but the side fairings work with the bumper to keep air flowing smoothly along the length of the tractor to boost fuel economy.

**“D” SHAPED FUEL TANK:** Pinnacle is available with this unique tank design that holds more fuel in the same space.

**CAB AIR SPRINGS:** Drivers can work more comfortably thanks to large, outboard-mounted air springs that provide cushioning, stability and reduced vibration.

**HOOD SAFETY LATCH:** The hood safety latch engages automatically and keeps the hood up, even in the windiest conditions. Disengage the latch by simply flipping it up before closing the hood.

**LARGE PEEP WINDOW:** The large peep window and visibility door provide exceptional views, and the quick release mechanism allows easy access for cleaning.

**SUN VISOR:** Stainless steel or painted sun visors are available.

**AIR INTAKES:** Pinnacle features optional bright finish air intake vents.



**SMARTWAY® CERTIFIED:** We can build any Pinnacle Axle Back™ sleeper to qualify as SmartWay Certified as it reduces fuel consumption and lowers emissions of greenhouse gases. To meet the EPA's requirements, trucks are equipped with full-roof and fuel-tank fairings, side-extendors and an aerodynamic front bumper to reduce drag and improve fuel economy by as much as 30 percent. This eco-friendly tractor rides on low-rolling resistance tires and uses the Idle-Free™ “Key-Off” HVAC System.



# A WELL-DESIGNED DASH IS WITHIN REACH

Sitting in the driver's seat of the Pinnacle™ is a lot like sitting in a cockpit. The dash wraps around so all switches and controls are close to the driver. There's no stretching, so there's less fatigue. Lighting controls can be reached from the ground to facilitate pre-trip inspections. The standard instrument cluster has been enhanced to include integrated gauge warning lamps, an engine oil temperature gauge, a digital voltmeter and a water-in-fuel indicator. A large, easy-to-read, standard driver display features an odometer, maintenance indicator, hour meter, Sweet Spot indicator and an ambient temperature gauge to name a few.



**STEERING COLUMN:** The steering column can be adjusted to an infinite amount of positions for maximum comfort, increased belly room and improved visibility of all gauges by simply pressing the quick-release foot pedal.



**AN ALL-IN-ONE DISPLAY:** The available Navion™ R5000 and T7000 navigational radios have a 7-inch, color LCD screen that fits Pinnacle's standard in-dash radio slot. The system integrates entertainment, navigation, a blind spot camera display and vehicle, trip and tire-pressure monitoring systems. The entertainment system includes an AM/FM/weather band radio, CD player, digital inputs for MP3® players and USB memory devices, and a satellite radio controller.





**DASH FINISHES:** The dash comes nicely appointed in three finishes: woodgrain (opposite page), brushed nickel (at left) or charcoal.

**CO-PILOT™:** Pinnacle features the Co-Pilot driver information display. Mounted high and centered in the dash for easy reading, this large display sets the industry standard. Drivers can easily toggle through a four-button steering-column stalk. This innovative display has 50 screens that provide real-time fuel economy and trip data, detailed maintenance and fault summaries, and supplemental sensor readings. Co-Pilot allows you to equip your truck with specialized features like Theft Deterrence, the Mack Fuel Economy Incentive Program and GuardDog™ Maintenance Monitoring System.

**V-MAC® IV:** Electronics offer both drivers and managers a way to boost productivity. The Mack Pinnacle has our time-tested and road-proven Vehicle Management and Control System or V-MAC IV. This next-generation of advanced electronics gives you greater control of your costs and lets you monitor your truck and engine better than ever. In addition to over a hundred proven programmable features, V-MAC IV adds a host of new items, including ABS-based tamper detection, integrated starter protection and programmable daytime running light overrides. V-MAC IV electronics comes with DataMax™, an advanced trip recorder that captures vehicle trip histories, duty cycle information and scheduled maintenance intervals.

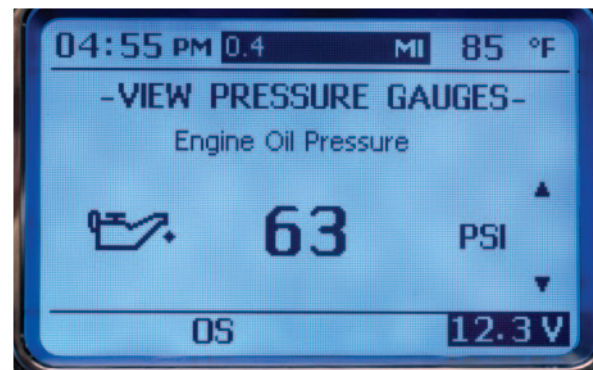

**COMFORTABLE PEDALS:** The pedals on the Pinnacle are suspended above the cab floor with the accelerator and brake pedals mounted in-line to reduce operator effort while driving. The clutch pedal is available with air assist, lowering the pedal and greatly reducing driver effort. When combined with our new deep cab and strategically placed seat and steering column, drivers conserve energy and work more productively.



# TRIM LEVELS

From the finish on the dash to the style of the steering wheel and a trio of optional trim levels, we worked hard to create an array of choices that fit your style.

## GRAND TOURING

MACK® GRILLE CLOTH



DEEP COPPER

PLEATED ULTRALEATHER™



COBALT BLUE



SLATE GRAY



CHROME WITH A STITCHED LEATHER GRIP

## CUSTOM

DIAMOND PLATE CLOTH



DEEP COPPER



COBALT BLUE



SLATE GRAY



BRUSHED NICKEL WITH A FIRM GRIP FEEL

LEATHER



## GENUINE



STONE GRAY



CHARCOAL WITH A FIRM GRIP FEEL

**DRIVER SEAT:** The air-suspension driver's seat is wide and comfortable, easily adjusting to fit any body size. The Grand Touring trim level comes with stylish Ultraleather and cloth accent seats (shown at right).



## A TRUE SANCTUARY FOR DRIVERS

Pinnacle™ has a spacious cab that defines comfort. Its ergonomic design gives drivers plenty of leg, belly and headroom. Air-suspended cab mountings protect drivers from harsh, rough roads. Getting in and out of the cab is nearly effortless thanks to the strategically placed steps and grab handles. And the interior is easy to clean — from the tough, paw-print signature floor mat to the beautiful dash.

**SUPERIOR CAB LIGHTING:** The Pinnacle cab features best-in-class, four-point cab lighting that reduces dangerous glare and illuminates key spots in the cab.

**LIGHTING CONTROLS:** Lighting controls can be easily accessed from the ground to facilitate pre-trip inspections.

**OVERHEAD STORAGE:** The cab has plenty of convenient storage bins as the roomy overhead console is divided into three compartments — with netting to better hold your belongings, and a center compartment ideal for mounting a CB radio.

**STAY ORGANIZED:** There's a place in this cab for all your stuff. Drivers will find a large dispatch box in the rear panel for more storage, as well as a specially designed peg to hang a trash bag. Large cup holders are easy to reach and positioned a safe distance from electronics in case of spills.

**ONE QUIET RIDE:** Mack® uses a lightweight, high-tech sound deadening material to dull the roar of the road. Noise in the cab has been reduced to the level found in most cars so drivers don't have to fight noise to stay comfortable.

**CONTROL YOUR ENVIRONMENT:** Pinnacle™ is equipped with an advanced heating and cooling system, providing great airflow. The fan is quieter to promote greater driver comfort. Additional heating and cooling controls are in the sleeper cabin for convenience.

**IMMENSE STORAGE:** A locking storage compartment under the lift-up bunk conveniently separates truck supplies from personal belongings. A mix of tall closets and smaller cabinets let you neatly store shirts, coats and other important items.

**UNEXPECTED COMFORT:** With a full-size innerspring mattress, TV/VCR, refrigerator and convenient 12-volt outlets, you have all the amenities you need for rest and relaxation.

**IDLE-FREE™ “KEY-OFF” HVAC SYSTEM:** With the available Idle-Free “Key-Off” HVAC System drivers can enjoy a comfortable truck without wasteful idling during rest periods. This system, which has a convenient control panel in the sleeper, supplies electrical power for amenities. It also saves fuel, reduces engine wear and cuts emissions for a cleaner environment.



70" HIGH-RISE INTERIOR



# STAND OUT FROM THE CROWD

Making a good impression is important. You want to project an image of success and pride, and the Mack® Pinnacle™ helps owner-operators do just that with the bold, classic design of the axle forward model that is the very embodiment of American trucking. And since the upgraded Rawhide™ Edition, which comes with tons of factory-installed, warranty-covered chrome accessories, is only available on axle forward models, this is the Mack that truly reflects your individuality.

Pinnacle in an axle forward configuration (shown this page) is built for optimum weight distribution as the forward position of the axle helps balance out your load.



DAYCAB



60" MID-RISE



70" MID-RISE RAWHIDE EDITION

THE PINNACLE AXLE FORWARD IS AVAILABLE IN A DAYCAB MODEL, 48- AND 56-INCH FLAT-TOP SLEEPERS, 60- AND 70-INCH MID-RISE SLEEPERS AND IN A 70-INCH HIGH-RISE SLEEPER.

HEAVY SPEC DAYCAB



20 TON  
LIMIT MAX

MACK

MACK

# RAWHIDE™ EDITION

Climb inside the Mack® Pinnacle™ Rawhide Edition and experience cab comforts designed to impress. The well-appointed cab combines a brushed nickel dash, a leather-grip steering wheel and two-tone Ultraleather™ seats with Rawhide logo and bold stitching to create an enviable work environment.

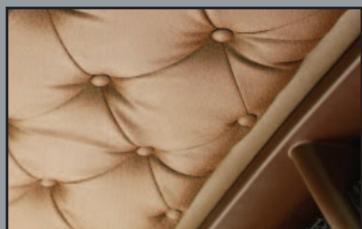

BUCKSKIN

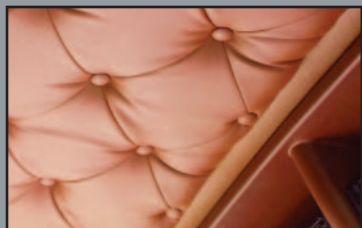

DEEP COPPER

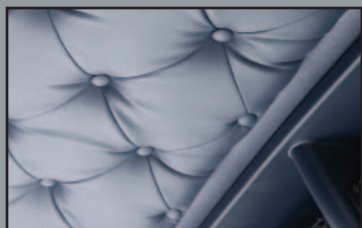
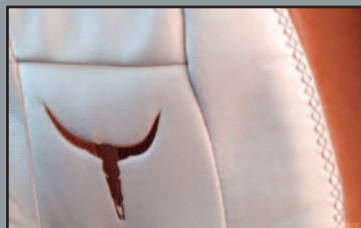

SLATE GRAY

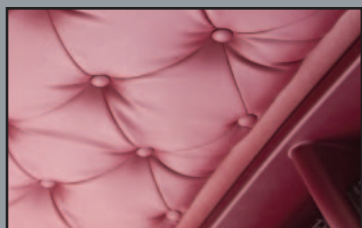

OXBLOOD

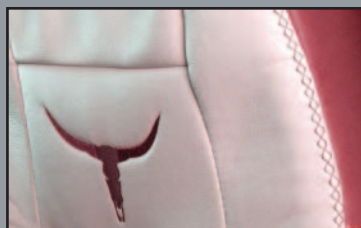





THE PINNACLE RAWHIDE EDITION IS AVAILABLE ON THREE AXLE FORWARD MODELS: DAYCAB, 60" MID-RISE SLEEPER AND 70" MID-RISE SLEEPER (SHOWN ABOVE WITH FULL ROOF FAIRINGS).

## INTERIOR

- Ultraleather button-tuck trim in Classic Buckskin Deep Copper, Slate Gray or Vintage Oxblood
- Leather-grip steering wheel with bright chrome spokes and brushed chrome Mack horn cap
- Premium brushed nickel dash with chrome gauge bezels
- Full gauge cluster
- Co-Pilot™ driver display
- Bostrom® LSO high-back air-ride driver seat in two-tone Ultraleather with Rawhide logo and bold stitching
- Fixed high-back air-ride passenger seat in two-tone Ultraleather with Rawhide logo, bold stitching and integral storage compartments
- Power windows and locks with bright-finish cover plates
- Bright-finish door handles
- Floor mat with polished, diamond-plate inserts

### OPTIONAL SLEEPER FEATURES

- Sleeper box exit door, RH only
- Luggage compartment with RH and LH access doors and paddle latches
- Tinted sliding side windows

## EXTERIOR

- Bright-finish, dual-vertical, seven-inch chrome bullhorn stacks
- Stainless steel, 13-inch-deep exterior sun visor
- Quad trumpet air horns with snow shields
- Bright-finish air intake grille
- Bright-finish grille surround
- Chrome bullet LED cab marker and clearance lamps
- Bulldog-stylized, heated, motorized and illuminated mirrors with integrated convex
- Stainless steel hood latches
- Stainless steel cab skirts
- Polished aluminum fuel tank
- Bright-finish fuel tank steps with three-inch-wide straps
- Polished aluminum battery box cover
- Bright-finish heat shield for Mack Cap DPF
- Extended, stylized bright-finish steel bumper with stone guard
- Bright-finish grab handles

# STRONG ENOUGH TO CARRY YOUR BUSINESS

The Mack® Pinnacle™ rides on the Advantage™ chassis, a lightweight-yet-strong frame that can be spec'd to work best with your application. Choose from four rail sizes ranging from 6 mm to 9.5 mm that offer more RBMs and less weight. You also have your pick of a variety of Mack engineered crossmembers to help you minimize weight, maximize strength and work at the highest level of productivity.

**MAXIMUM MANEUVERABILITY:** The Advantage chassis gives drivers an improved turning radius to help get out of tight spaces with less hassle. Outside wheel cuts of up to 50 degrees help with maneuverability.

**UNIMAX™ AXLES:** UniMax steer axle hubs are sealed and maintenance free and require no servicing. The short distance from bumper to tire provides front-end swing clearance, outstanding wheel cuts and an exceptional turning radius.

**DRIVELINE ANGLE OPTIMIZED:** The driveline angle is optimized for longer component life and minimal vibration.

**AXLE CAPACITY OPTIONS:** Camelback or Walking Beam air suspensions are offered with Pinnacle to fit heavy-duty applications. Front axles and suspensions are available from 12,000- to 14,600-lb. capacity. Rear axles and suspensions are offered from 38,000- to 46,000-lb. capacity.

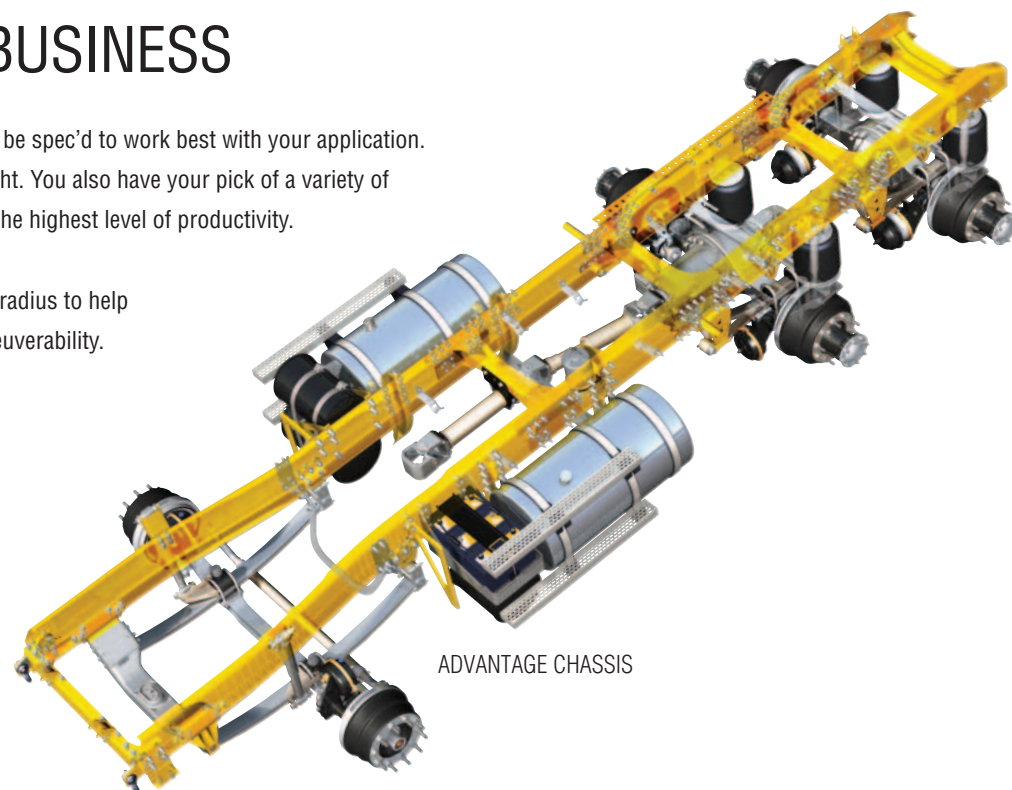

ADVANTAGE CHASSIS



CAMELBACK™



WALKING BEAM™

**MAXLITE™ SUSPENSIONS:** The re-engineered MaxLite 20EZ and 40EZ suspensions are ideal for highway applications as they offer reduced weight on the chassis while maintaining the strength and durability you've come to trust from Mack suspensions. The MaxLite suspensions incorporate aluminum torque rods instead of heavy steel rods, and feature an improved bracket and mounting design that attaches to the axle housing. The design also calls for newly designed fabricated steel attachment brackets as opposed to cast metal.



**SUPERIOR PERFORMANCE:** The chassis is engineered to provide excellent maneuvering in tight spaces. The sloped hood and big mirrors give drivers excellent visibility. The reinforced cab is extremely durable — built to survive thousands of hours of punishment without losing its integrity. Drivers can work more comfortably thanks to large, outboard-mounted air springs that provide cushioning, stability and reduced vibration.

**HASSLE-FREE CONNECTIONS:** Color-coded air lines mounted with stand-off brackets and push-to-connect fittings reduce leaks and provide quick and simple line tracking.

**ROAD CONNECT™:** Pinnacle features the Road Connect satellite-based communications system that provides coast-to-coast real-time, two-way communications between the vehicle and any internet-enabled computer. Services include two-way driver messaging, vehicle GPS, optimum routing, fuel purchase pricing, fuel-tax consumption and logged vehicle data transfer. Road Connect has low initial installation cost and affordable monthly fees so you can stay in touch with your fleet and run more efficiently.

**ADAPTIVE CRUISE CONTROL:** The available Adaptive Cruise Control helps avoid collisions for improved safety and reduced repair costs. Using the Mack Road Stability Advantage by Bendix® it ties the sensors to the cruise control and engine brake; and uses a front sonar device to automatically slow down and in some cases bring the vehicle to a complete stop, if necessary, when it senses an interference in a set range. It does this without any input or action from the driver. It is especially helpful in poor driving conditions, where sonar is not affected.



**MACK ROAD STABILITY ADVANTAGE:** The Mack Road Stability Advantage by Bendix is standard for improved performance. This ABS-based system recognizes and helps reduce rollover and vehicle under- and over-steer driving in a variety of road conditions. The Mack RSA system helps to mitigate loss of control by selectively applying vehicle brakes, as well as dethrottling the engine, and it does so faster than a human in most situations.



## THESE ENGINES ARE ALL MUSCLE

The MP™ Engine Series is the heartbeat of the Mack® Pinnacle™. These highly fuel-efficient engines deliver plenty of horsepower plus great low-end torque to give you all the muscle you need to conquer the road. The MP7 engine has a horsepower range from 325 to 405 HP while the MP8 provides horsepower from 415 to 505 HP. Either the MP7 or MP8 engine can be installed in axle back models. Axle forward models are only available with the MP8 engine.

**EASY SERVICING:** The MP Engine Series features 30,000-mile oil drain intervals and provides convenient access points that make servicing a snap.

**BUILT LIKE A MACK TRUCK®:** The MP Engine Series is designed with fewer parts, including one-piece steel pistons and stronger bearings and cylinder heads, giving operators a true powerplant that's built to last.

**VARIABLE GEOMETRY TURBOCHARGER:** The electronically controlled Variable Geometry Turbocharger incorporates the latest technology to cool both the turbo and the actuator.

**SINGLE OVERHEAD CAM:** These state-of-the-art engines have a single overhead cam with ultra-high-pressure fuel injection.

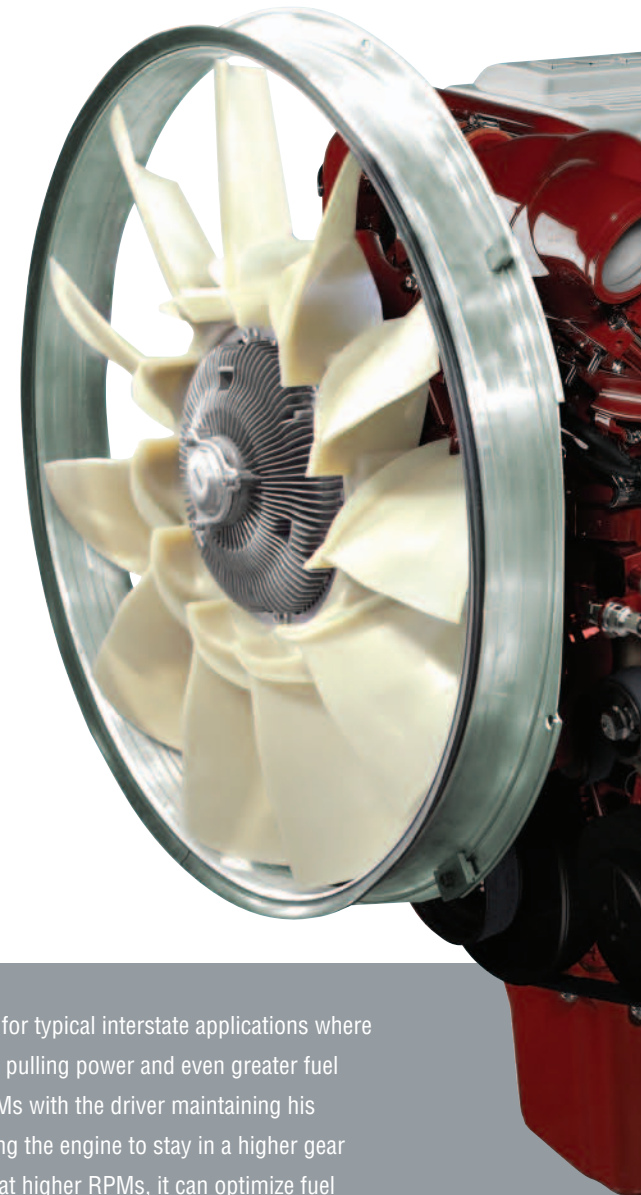

MAXICRUISE®	
ENGINE	HP
MP7	345C
MP7	365C
MP7	395C
MP8	415C
MP8	445C
MP8	505C
ENGINE TORQUE LEVELS MP7: 1,360–1,560 lb.-ft. MP8: 1,660–1,760 lb.-ft.	

ECONODYNE®	
ENGINE	HP
MP7	325E
MP7	355E
MP7	405E
MP8	415E
MP8	445E
MP8	505E
ENGINE TORQUE LEVELS MP7: 1,260–1,460 lb.-ft. MP8: 1,460–1,760 lb.-ft.	

**ECONOBOOST KEEPS DRIVERS IN HIGH GEAR:** The Econodyne® engine, which is best for typical interstate applications where fuel economy is a priority, just got better. With the EconoBoost system, drivers get increased pulling power and even greater fuel economy. EconoBoost supplies additional torque exactly when a driver needs it. In lower RPMs with the driver maintaining his speed for four seconds, EconoBoost provides up to an additional 200 lb.-ft. of torque, allowing the engine to stay in a higher gear to crest a hill. Because EconoBoost provides torque at lower RPMs and not just horsepower at higher RPMs, it can optimize fuel economy by an additional 1.5 percent. The MaxiCruise® engine performs best on rolling interstates and in on- and off-road applications.



**MACK CLARTECH™ SCR SYSTEM:** Mack remains at the forefront of engine development, incorporating selective catalytic reduction (SCR) technology into its MP engine platform for 2010. The Mack ClearTech SCR System creates clean-running engines that boast near-zero emissions (without the use of emissions credits) and even better fuel efficiency. Already used successfully in hundreds of thousands of trucks around the world, SCR is a proven, reliable approach.

**ClearTech™**  
**SCR SYSTEM**

**MACK POWERLEASH™:** The Mack PowerLeash engine brake provides more braking horsepower through mid-RPM ranges, and weighs 50 pounds less than other engine brakes. It is fully integrated with the MP Engine Series, and with better braking over the entire speed range, PowerLeash delivers the most retarding horsepower ever in a Mack engine brake. Drivers will immediately notice the near-instantaneous engine braking, giving drivers confidence behind the wheel. For trucks with automated transmissions, the quick response also enhances downshifting performance.

**INTEGRATED POWERTRAINS:** Mack is the only truck manufacturer offering the benefits of integration and single-source accountability for the engine, transmission and chassis, giving you not only the industry's best-built transmission, but also peace of mind knowing all Mack transmissions are engineered to work in concert with the engine to create powerful, reliable powertrains.

**MACK TRANSMISSIONS:** Built exclusively for Pinnacle tractors, the Mack *mDRIVE™* transmission is an automated-manual, 12-speed, two-pedal transmission that maximizes driver comfort, payload and fuel economy. The Mack Maxitorque® ES transmission is another strong option. It features the industry's only triple-countershaft design; standard, one-piece aluminum casings; and more PTO mounting options than any other transmission.

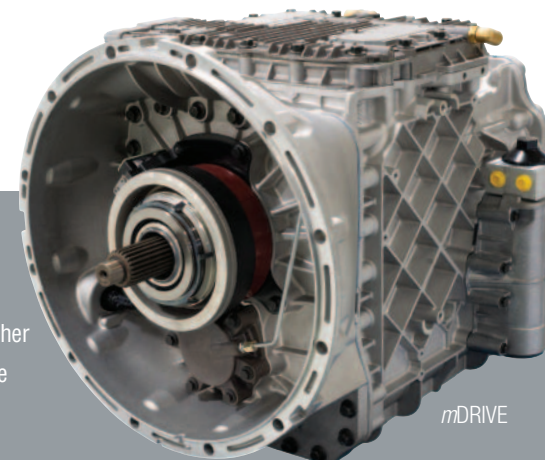

*mDRIVE*

## ENGINE: MACK® MP7 OR MP8

### Horsepower and Torque

MP8 – 13 Liter With 415 To 505 HP And Torque Ratings From 1,540 To 1,760 ft.-lbs.

MP7 – 11 Liter With 325 To 405 HP And Torque Ratings From 1,200 To 1,560 ft.-lbs.

Mack PowerLeash™ Engine Brake – (MP7 – 420 HP At 2,100 RPM / MP8 – 425 HP At 2,100 RPM)

REPTO (Rear Engine Power Takeoff) – SAE 1350

V-MAC® IV – Total Vehicle Electronics

Air Compressor – 18.5 cfm / 37.4 cfm

Mack Coolant Conditioner

ClearTech™ SCR – Available Horizontal or Back-Of-Cab

Diesel Particulate Filter – Mack Cap (Passenger Side Under Step)

Single Or Dual Vertical Exhaust

Silicone Engine Hoses And Tubing

Poly-V Fan Belt With Automatic Tensioner

Fan Drive, Electronically Modulated Multi-Speed Viscous / On-Off

Flywheel Housing – Aluminum (Lightweight)

Radiator – Aluminum Core

Electronic Starter Interlock

## TRANSMISSIONS

Clutch – Self And Manual Adjusting Mechanical Cable – Standard

Air Operated Clutch Assist Pedal – Optional

Transmission Bell Housing – Aluminum Or Iron

PTO (Power Takeoff) Up To Six Openings, SAE 6 + 8

Transmissions\*

Mack TM308 Maxitorque® ES Shift Triple-Counter Shaft	8 Speed	17.77 / 0.71 Ratio (Low/High)
Mack TM308M Maxitorque ES Shift Triple-Counter Shaft	8 Speed	17.77 / 0.71 Ratio (Low/High)
Mack TM309 Maxitorque ES Shift Triple-Counter Shaft	9 Speed	25.21 / 0.71 Ratio (Low/High)
Mack TM309M Maxitorque ES Shift Triple-Counter Shaft	9 Speed	25.21 / 0.71 Ratio (Low/High)
Mack T309 Maxitorque ES Shift Triple-Counter Shaft	9 Speed	11.40 / 0.71 Ratio (Low/High)
Mack T309(LR) Maxitorque ES Shift Triple-Counter Shaft	9 Speed	13.93 / 0.71 Ratio (Low/High)
Mack T310 Maxitorque ES Shift Triple-Counter Shaft	10 Speed	13.81 / 0.73 Ratio (Low/High)
Mack T310M Maxitorque ES Shift Triple-Counter Shaft	10 Speed	17.35 / 0.73 Ratio (Low/High)
Mack T310ME Maxitorque ES Shift Triple-Counter Shaft	10 Speed	17.35 / 0.73 Ratio (Low/High)
Mack T310MLR Maxitorque ES Shift Triple-Counter Shaft	10 Speed	27.31 / 0.71 Ratio (Low/High)
Mack T313 Maxitorque ES Shift Triple-Counter Shaft	13 Speed	13.44 / 0.74 Ratio (Low/High)
Mack T313LR Maxitorque ES Shift Triple-Counter Shaft	13 Speed	16.42 / 0.71 Ratio (Low/High)
Mack T318 Maxitorque ES Shift Triple-Counter Shaft	18 Speed	13.44 / 0.71 Ratio (Low/High)
Mack T318LR Maxitorque ES Shift Triple-Counter Shaft	18 Speed	16.42 / 0.71 Ratio (Low/High)
Mack mDRIVE™ Automated MT-Premium (Overdrive)	12 Speed	11.73 / 0.79 Ratio (Low/High)
Mack mDRIVE Automated MT-Fleet (Direct Drive)	12 Speed	14.94 / 1.00 Ratio (Low/High)
Allison® – EVS Or RDS	5 Speed	3.51 / 0.74 Ratio (Low/High)
Allison – EVS Or RDS	6 Speed	3.51 / 0.74 Ratio (Low/High)
Eaton® Fuller® Roadranger® Twin Counter Shaft	9 Speed	12.57 / 0.73 Ratio (Low/High)
Eaton Fuller Roadranger Twin Counter Shaft	10 Speed	12.69 / 0.74 Ratio (Low/High)
Eaton Fuller Roadranger Twin Counter Shaft	11 Speed	26.08 / 0.73 Ratio (Low/High)
Eaton Fuller Roadranger Twin Counter Shaft	13 Speed	12.31 / 0.73 Ratio (Low/High)
Eaton Fuller Roadranger Twin Counter Shaft	15 Speed	13.31 / 0.79 Ratio (Low/High)
Eaton Fuller Roadranger Twin Counter Shaft	18 Speed	14.40 / 0.73 Ratio (Low/High)

\*Other Supplier Transmissions Available

## AIR / BRAKE

Dual Air Brake System

Anti-Lock Brake System With Or Without Traction Control

Mack Road Stability Advantage™ System

## ELECTRICAL

12-Volt Electrical System

Battery Box – Steel With Molded Plastic Cover Mounted LH Rail

Courtesy Light Switch – Headlamp And Clearance

Daytime Running Lights

Electric Circuit Protection Package

Waterproof Electrical Connections

Headlights – Halogen Flush With Replaceable Bulbs

Step-Mounted LED Work Lights

## CAB INTERIOR / EXTERIOR SPECIFICATIONS

Air Conditioner With Integral Heater And Replaceable Filter

Air Cleaner With Restriction Monitor

Cab Mounting – Four-Point System With Two Air Bags And Canted Shocks

Interior Lighting, 2 Lamps LH / 2 Lamps RH

Galvanized Steel Visibility Doors With Passenger Peep Window

Keyless Entry

Floor Mats – Polyurethane Mack Signature Pawprint

Grille – Silver Painted Or Bright Finish With Or Without Grille Surround

Hood And Fenders – Fiberglass, Camoplast

Fuel Tanks – “D” Shaped 22” and 26”

Identification And Clearance Lights (5)

Co-Pilot™ Driver Display

Instrument Panel – Brushed Nickel, Woodgrain Or Charcoal

Exterior Mirrors – Bulldog® Stylized Or Aerodynamic Mirrors Available Lighted / Heated / Motorized

Parking Brake On Indicator Light

Overhead Console, 3 Storage Compartments With Net Retainers

12-Volt Auxiliary Power Outlets (2) – Dash Mounted

AM/FM Stereo CD With Weather Band – Premium Radio Package Available

Driver Seat – Bostrom Talladega® 915 Mid-Back Air Suspension

Rider Seat – Mack Fixed Mid-Back Non-Suspension

Steering Column – Adjustable Tilt And Telescopic

Rear Storage Pouch

Interior Sun Visor – Full Width

Exterior Sun Visor – Bright Finish Or Painted

Windshield – Safety Tinted 2-Piece

Safety Tinted Side And Rear Windows

Intermittent Windshield Wipers

Paint – Custom Color Available For Cab, Chassis And Wheels



PINNACLE™ AXLE FORWARD

### FRONT AXLE AND SUSPENSION

Mack UniMax™ Axles With Integrated Hub
12,000, 14,600, 18,000, 20,000 And 23,000 lb. Capacity
Hub Material – Ferrous Or Aluminum
Inbound Cast Or Outbound Cast Centrifuse
Brakes – Meritor® “S” Cam Q-Plus With Or Without Dust Shields (16.5 x 6)
Slack Adjusters – Automatic
Suspension – Mack Taperleaf 12,000 – 23,000 lb.
Suspension – Mack Multileaf 12,000 – 23,000 lb.
Steering Gear
Power – 12,000, 12,600 Or 18,000 lb.
Heavy-Duty – 20,000 Or 23,000 lb.

### REAR AXLE AND SUSPENSION

Rear Axle
Bogies – 38,000 – 65,000 lb. Capacity
Tri-Drive – 69,000 lb. Capacity
Special Order – 80,000 – 110,000 lb. Capacity
Carrier
Top-Mounted Aluminum, Double Reduction
Power Divider Lockout
Hub Material – Ferrous Or Aluminum
Brakes – Meritor “S” Cam Q-Plus With Or Without Dust Shields (16.5 x 7)
Inbound Cast Or Outbound Cast Centrifuse
Slack Adjusters – Automatic
Suspension
Mack Multileaf (Camelback), MaxLite™ Hendrickson®

The information in this brochure was accurate as known as of the date of the publication. Illustrations may not be representative of current product. Mack Trucks, Inc. reserves the right to make changes in specifications, equipment or design, or to discontinue models or options without notice at any time.



PINNACLE AXLE BACK

### CHASSIS DIMENSIONS

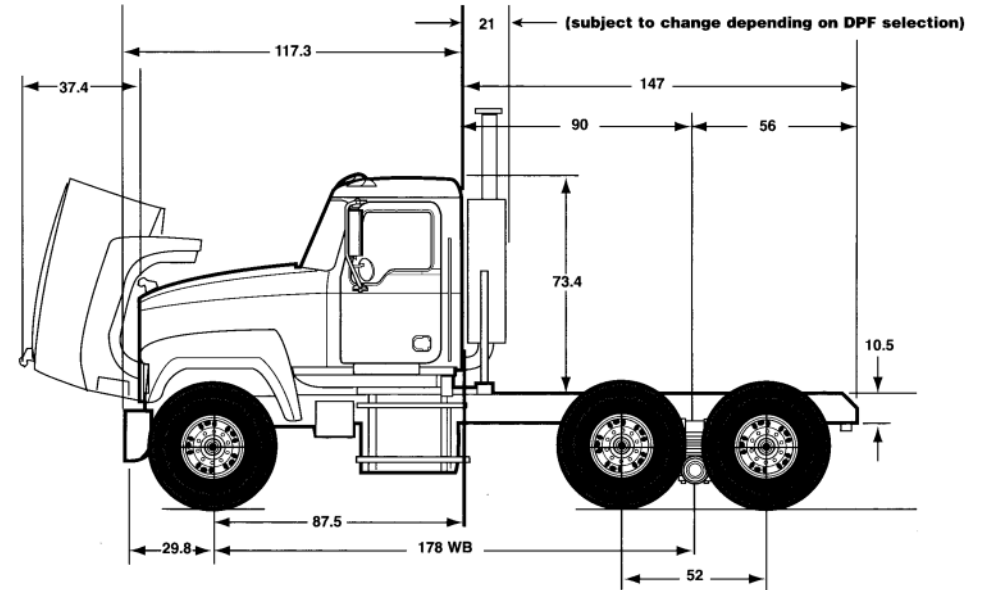

AXLE FORWARD SHOWN

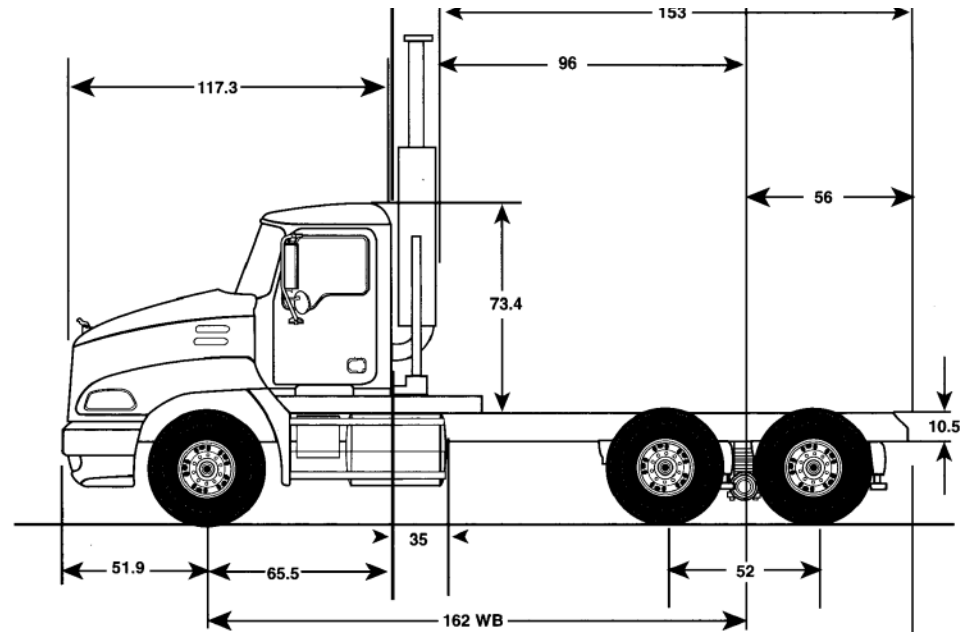

AXLE BACK SHOWN

ALL MEASUREMENTS IN INCHES.